

TPS54227 4.5-V to 18-V Input, 2-A Synchronous Step-Down Converter

1 Features

- D-CAP2™ Mode Enables Fast Transient Response
- Low Output Ripple and Allows Ceramic Output Capacitor
- Wide V_{IN} Input Voltage Range: 4.5 V to 18 V
- Output Voltage Range: 0.76 V to 7 V
- Highly-Efficient Integrated FETs Optimized for Lower Duty Cycle Applications
 - 155 m Ω (High-Side) and 108 m Ω (Low-Side)
- High Efficiency, Less Than 10 μ A at Shutdown
- High Initial Bandgap Reference Accuracy
- Adjustable Soft-Start
- Prebiased Soft-Start
- 700-kHz Switching Frequency (f_{SW})
- Cycle-By-Cycle Overcurrent Limit

2 Applications

- Wide Range of Applications for Low-Voltage System
 - Digital TV Power Supply
 - High-Definition Blu-ray Disc™ Players
 - Networking Home Terminals
 - Digital Set Top Boxes (STB)

Simplified Schematic

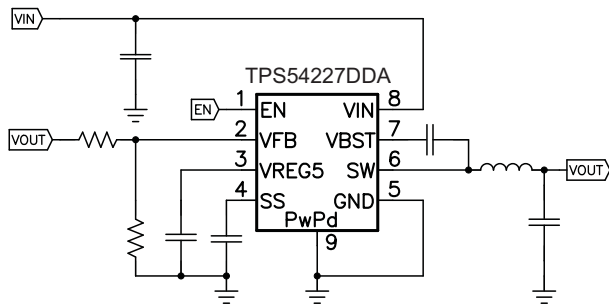

3 Description

The TPS54227 device is an adaptive ON-time D-CAP2 mode synchronous buck converter. The TPS54227 enables system designers to complete the bus regulators for a suite of various end equipment with a cost-effective, low component count, low standby current solution. The main control loop for the TPS54227 uses the D-CAP2 mode control which provides a fast transient response with no external compensation components. The TPS54227 also has a proprietary circuit that enables the device to adopt to both low equivalent series resistance (ESR) output capacitors, such as POSCAP or SP-CAP, and ultra-low ESR ceramic capacitors. The device operates from 4.5-V to 18-V V_{IN} input. The output voltage can be programmed between 0.76 V and 7 V. The device also features an adjustable soft-start time. The TPS54227 is available in the 8-pin HSOP package and 10-pin VSON, and is designed to operate from -40°C to 85°C .

Device Information⁽¹⁾

PART NUMBER	PACKAGE	BODY SIZE (NOM)
TPS54227	SO PowerPAD (8)	4.89 mm x 3.90 mm
	VSON (10)	3.00 mm x 3.00 mm

(1) For all available packages, see the orderable addendum at the end of the data sheet.

TPS54227 Transient Response

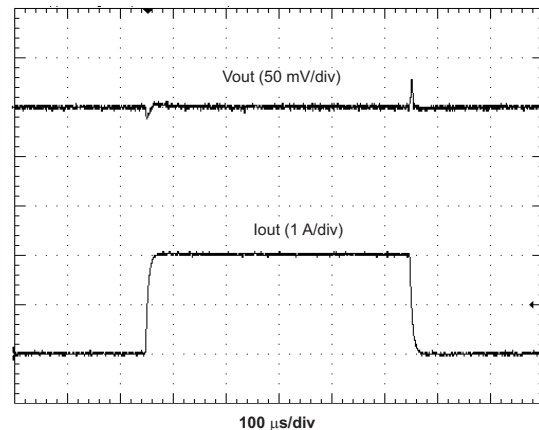

Table of Contents

1 Features	1	7.4 Device Functional Modes.....	10
2 Applications	1	8 Application and Implementation	11
3 Description	1	8.1 Application Information.....	11
4 Revision History	2	8.2 Typical Application	11
5 Pin Configuration and Functions	3	9 Power Supply Recommendations	15
6 Specifications	4	10 Layout	15
6.1 Absolute Maximum Ratings	4	10.1 Layout Guidelines	15
6.2 ESD Ratings.....	4	10.2 Layout Examples.....	15
6.3 Recommended Operating Conditions.....	4	10.3 Thermal Considerations	16
6.4 Thermal Information	5	11 Device and Documentation Support	17
6.5 Electrical Characteristics.....	5	11.1 Documentation Support	17
6.6 Typical Characteristics	6	11.2 Community Resources.....	17
7 Detailed Description	8	11.3 Trademarks	17
7.1 Overview	8	11.4 Electrostatic Discharge Caution.....	17
7.2 Functional Block Diagram	8	11.5 Glossary	17
7.3 Feature Description.....	8	12 Mechanical, Packaging, and Orderable Information	17

4 Revision History

NOTE: Page numbers for previous revisions may differ from page numbers in the current version.

Changes from Revision B (June 2013) to Revision C	Page
• Deleted <i>Ordering Information</i> table	1
• Added <i>Pin Configuration and Functions</i> section, <i>ESD Ratings</i> table, <i>Feature Description</i> section, <i>Device Functional Modes</i> , <i>Application and Implementation</i> section, <i>Power Supply Recommendations</i> section, <i>Layout</i> section, <i>Device and Documentation Support</i> section, and <i>Mechanical, Packaging, and Orderable Information</i> section	1

Changes from Revision A (October 2011) to Revision B	Page
• Removed (SWIFT™) from the data sheet title	1
• Added "and 10-pin DRC" to the DESCRIPTION	1
• Added the DRC-10 Pin package pin out	3
• Changed the VBST(vs SW) MAX value From: 5.7V to 6V in the ROC table.....	4
• Added High-side switch resistance (DRC)	5
• Added a conditions statement "VIN = 12 V, T _A = 25°C" to the TYPICAL CHARACTERISTICS	6
• Changed Figure 11 title From: 1.05-V, 50-mA to 2-A LOAD TRANSIENT RESPONSE To: 1.05-V, 0-A to 2-A LOAD TRANSIENT RESPONSE	13
• Added Figure 18	16

Changes from Original (May 2010) to Revision A	Page
• Corrected the pin numbers for Pins 5 through 8	3
• Added R _{EN} - EN pin resistance to GND to the LOGIC THRESHOLD section of the ELECTRICAL CHARACTERISTICS table	5

5 Pin Configuration and Functions

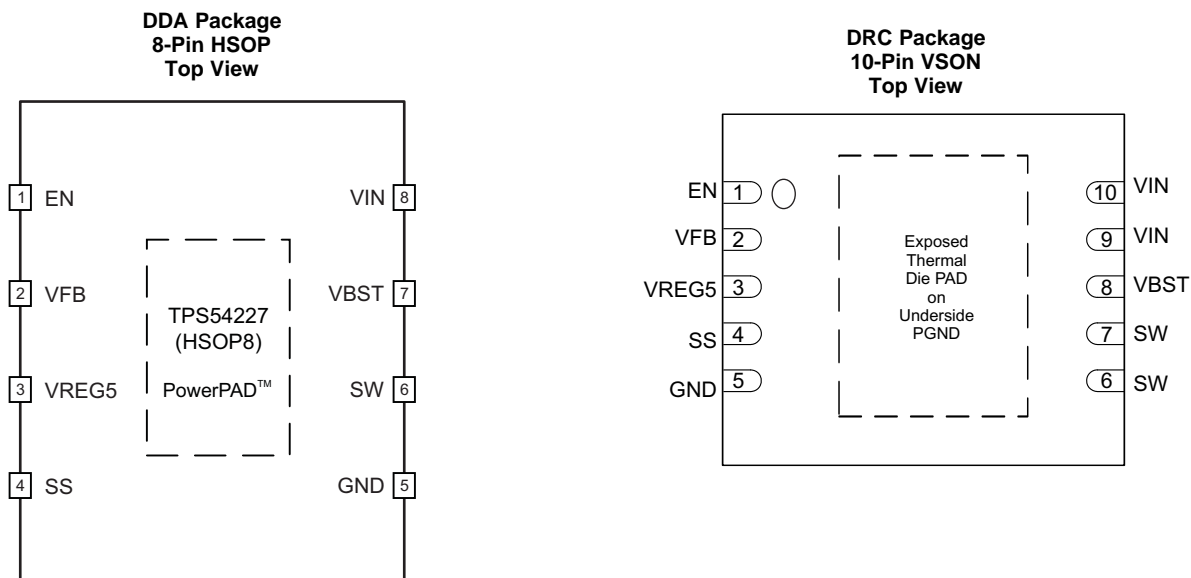

Pin Functions

NAME	PIN		I/O	DESCRIPTION
	DDA	DRC		
EN	1	1	I	Enable input control. EN is active high and must be pulled up to enable the device.
Exposed Thermal Pad	—	—	G	Thermal pad of the package. Must be soldered to achieve appropriate dissipation. Must be connected to GND.
	—	—		Thermal pad of the package. PGND power ground return of internal low-side FET. Must be soldered to achieve appropriate dissipation.
GND	5	5	G	Ground pin. Power ground return for switching circuit. Connect sensitive SS and VFB returns to GND at a single point.
SS	4	4	O	Soft-start control. An external capacitor should be connected to GND.
SW	6	6, 7	O	Switch node connection between high-side NFET and low-side NFET.
VBST	7	8	I	Supply input for the high-side FET gate drive circuit. Connect 0.1- μ F capacitor between VBST and SW pins. An internal diode is connected between VREG5 and VBST.
VFB	2	2	I	Converter feedback input. Connect to output voltage with feedback resistor divider.
VIN	8	9, 10	P	Input voltage supply pin.
VREG5	3	3	O	5.5-V power supply output. A capacitor (typical 1 μ F) should be connected to GND. VREG5 is not active when EN is low.

6 Specifications

6.1 Absolute Maximum Ratings

 over operating free-air temperature range (unless otherwise noted)⁽¹⁾

		MIN	MAX	UNIT
Input voltage	VIN, EN	-0.3	20	V
	VBST	-0.3	26	V
	VBST (10-ns transient)	-0.3	28	V
	VBST (vs SW)	-0.3	6.5	V
	VFB, SS	-0.3	6.5	V
	SW	-2	20	V
	SW (10-ns transient)	-3	22	V
Output voltage	VREG5	-0.3	6.5	V
	GND	-0.3	0.3	V
Voltage from GND to thermal pad, V_{diff}		-0.2	0.2	V
Operating junction temperature, T_J		-40	150	°C
Storage temperature, T_{stg}		-55	150	°C

(1) Stresses beyond those listed under *Absolute Maximum Ratings* may cause permanent damage to the device. These are stress ratings only, which do not imply functional operation of the device at these or any other conditions beyond those indicated under *Recommended Operating Conditions*. Exposure to absolute-maximum-rated conditions for extended periods may affect device reliability.

6.2 ESD Ratings

		VALUE	UNIT
$V_{(ESD)}$ Electrostatic discharge	Human body model (HBM), per ANSI/ESDA/JEDEC JS-001 ⁽¹⁾	±2000	V
	Charged-device model (CDM), per JEDEC specification JESD22-C101 ⁽²⁾	±500	

(1) JEDEC document JEP155 states that 500-V HBM allows safe manufacturing with a standard ESD control process.

(2) JEDEC document JEP157 states that 250-V CDM allows safe manufacturing with a standard ESD control process.

6.3 Recommended Operating Conditions

over operating free-air temperature range (unless otherwise noted)

		MIN	MAX	UNIT	
V_{IN}	Supply input voltage range	4.5	18	V	
V_I	Input voltage range	VBST	-0.1	24	V
		VBST (10 ns transient)	-0.1	27	
		VBST(vs SW)	-0.1	6	
		SS	-0.1	5.7	
		EN	-0.1	18	
		VFB	-0.1	5.5	
		SW	-1.8	18	
		SW (10 ns transient)	-3	21	
	GND	-0.1	0.1		
V_O	Output voltage range	-0.1	5.7	V	
I_O	Output Current range	0	10	mA	
T_A	Operating free-air temperature	-40	85	°C	
T_J	Operating junction temperature	-40	150	°C	

6.4 Thermal Information

THERMAL METRIC ⁽¹⁾		TPS54227		UNIT
		DDA (HSOP)	DRC (VSON)	
		8 PINS	10 PINS	
R _{θJA}	Junction-to-ambient thermal resistance	45.3	43.9	°C/W
R _{θJC(top)}	Junction-to-case (top) thermal resistance	54.8	55.4	°C/W
R _{θJB}	Junction-to-board thermal resistance	16.2	18.9	°C/W
ψ _{JT}	Junction-to-top characterization parameter	6.6	0.7	°C/W
ψ _{JB}	Junction-to-board characterization parameter	16	19.1	°C/W
R _{θJC(bot)}	Junction-to-case (bottom) thermal resistance	8.5	5.3	°C/W

(1) For more information about traditional and new thermal metrics, see the *Semiconductor and IC Package Thermal Metrics* application report, [SPRA953](#).

6.5 Electrical Characteristics

over operating free-air temperature range, V_{IN} = 12 V (unless otherwise noted)

PARAMETER		TEST CONDITIONS	MIN	TYP	MAX	UNIT	
SUPPLY CURRENT							
I _{VIN}	Operating - non-switching supply current	V _{IN} current, T _A = 25°C, EN = 5 V, V _{FB} = 0.8 V		800	1200	μA	
I _{VINSDN}	Shutdown supply current	V _{IN} current, T _A = 25°C, EN = 0 V		5	10	μA	
LOGIC THRESHOLD							
V _{ENH}	EN high-level input voltage	EN	1.6			V	
V _{ENL}	EN low-level input voltage	EN			0.6	V	
R _{EN}	EN pin resistance to GND	V _{EN} = 12 V	220	440	880	kΩ	
V_{FB} VOLTAGE AND DISCHARGE RESISTANCE							
V _{FBTH}	V _{FB} threshold voltage	T _A = 25°C, V _O = 1.05 V, continuous mode	749	765	781	mV	
I _{VFB}	V _{FB} input current	V _{FB} = 0.8 V, T _A = 25°C		0	±0.1	μA	
V_{REG5} OUTPUT							
V _{VREG5}	V _{REG5} output voltage	T _A = 25°C, 6 V < V _{IN} < 18 V, 0 < I _{VREG5} < 5 mA	5.2	5.5	5.7	V	
V _{LN5}	Line regulation	6 V < V _{IN} < 18 V, I _{VREG5} = 5 mA			25	mV	
V _{LD5}	Load regulation	0 mA < I _{VREG5} < 5 mA			100	mV	
I _{VREG5}	Output current	V _{IN} = 6 V, V _{REG5} = 4 V, T _A = 25°C		60		mA	
MOSFET							
R _{DS(on)h}	High-side switch resistance (DDA)	25°C, V _{BST} - SW = 5.5 V			155	mΩ	
	High-side switch resistance (DRC)				165		
R _{DS(on)l}	Low-side switch resistance	25°C			108	mΩ	
CURRENT LIMIT							
I _{ocl}	Current limit	L out = 2.2 μH ⁽¹⁾	2.5	3.3	4.7	A	
THERMAL SHUTDOWN							
T _{SDN}	Thermal shutdown threshold	Shutdown temperature ⁽¹⁾			165	°C	
		Hysteresis ⁽¹⁾			35		
ON-TIME TIMER CONTROL							
t _{ON}	ON-time	V _{IN} = 12 V, V _O = 1.05 V			150	ns	
t _{OFF(MIN)}	Minimum OFF-time	T _A = 25°C, V _{FB} = 0.7 V			260	310	ns
SOFT-START							
I _{SSC}	SS charge current	V _{SS} = 1 V	1.4	2	2.6	μA	
I _{SSD}	SS discharge current	V _{SS} = 0.5 V	0.1	0.2		mA	
UVLO							
UVLO	UVLO threshold	Wake up V _{REG5} voltage	3.45	3.75	4.05	V	
		Hysteresis V _{REG5} voltage	0.13	0.32	0.48		

(1) Not production tested.

6.6 Typical Characteristics

V_{IN} = 12 V, T_A = 25°C (unless otherwise noted)

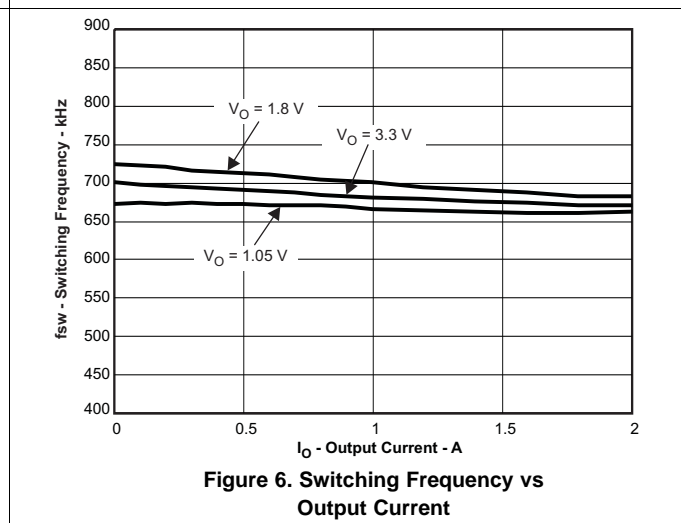
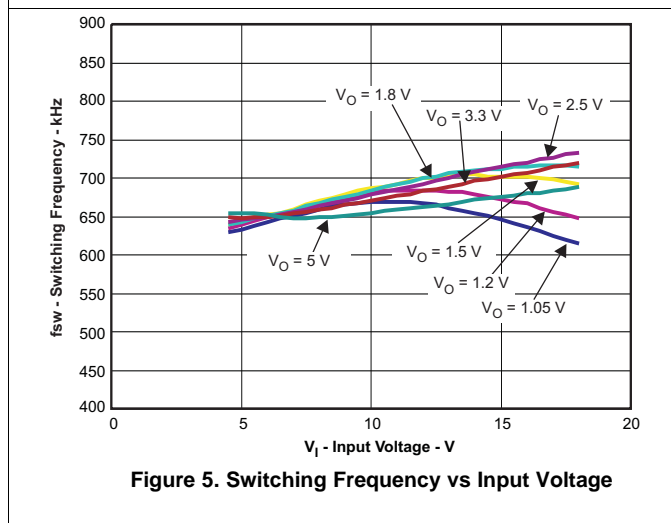
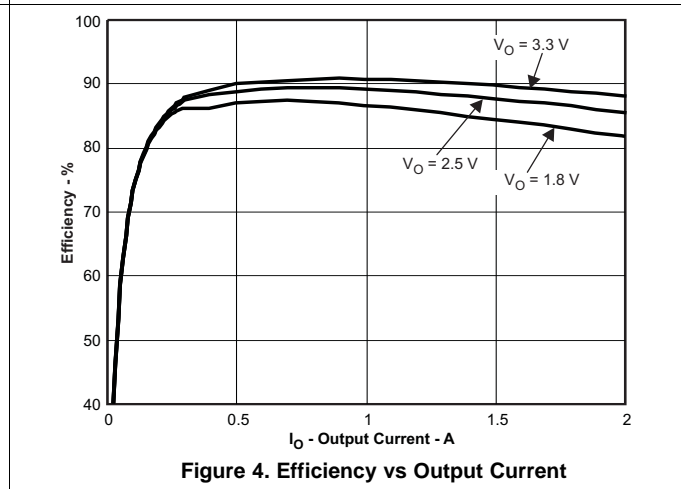
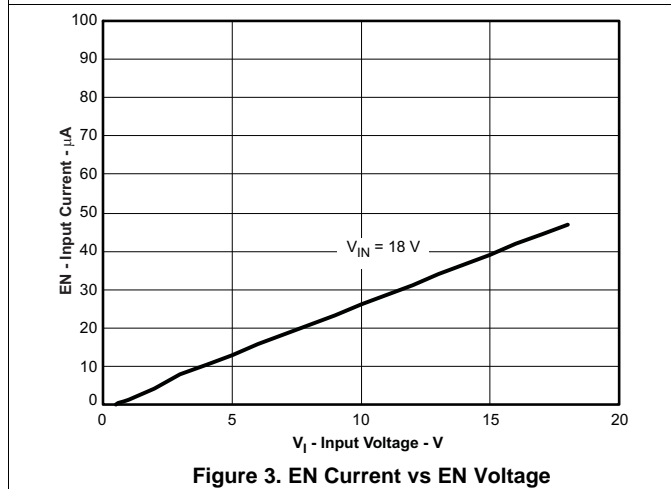
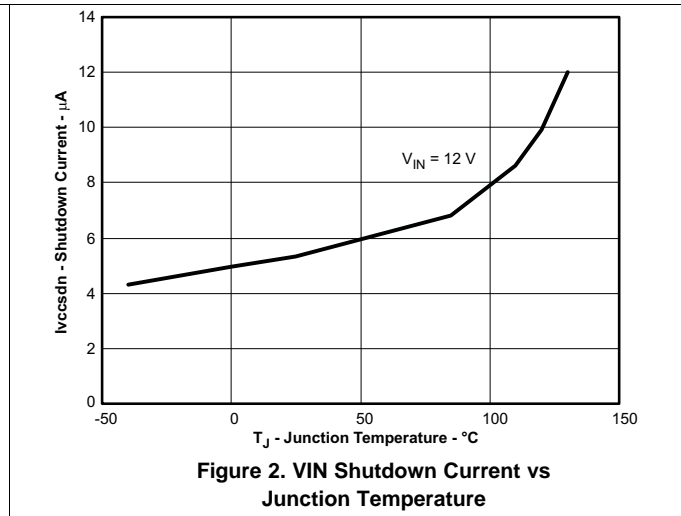
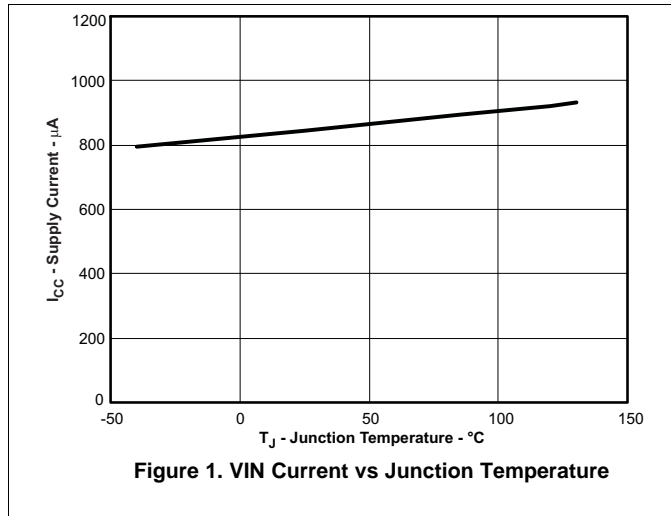

Typical Characteristics (continued)

V_{IN} = 12 V, T_A = 25°C (unless otherwise noted)

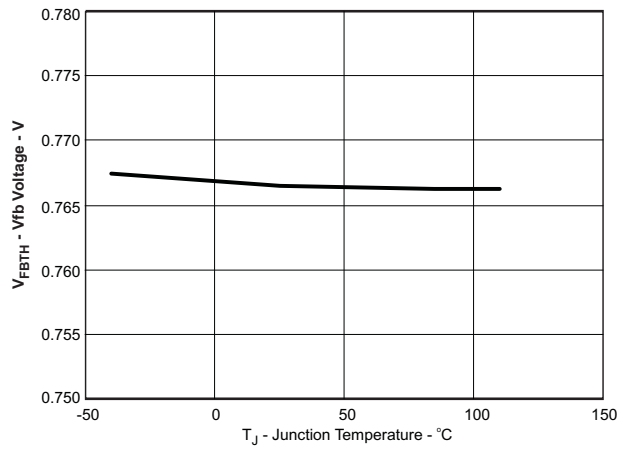

Figure 7. Vfb Voltage vs Junction Temperature

7 Detailed Description

7.1 Overview

The TPS54227 is a 2-A synchronous step-down (buck) converter with two integrated N-channel MOSFETs. It operates using D-CAP2 mode control. The fast transient response of D-CAP2 control reduces the output capacitance required to meet a specific level of performance. Proprietary internal circuitry allows the use of low ESR output capacitors including ceramic and special polymer types.

7.2 Functional Block Diagram

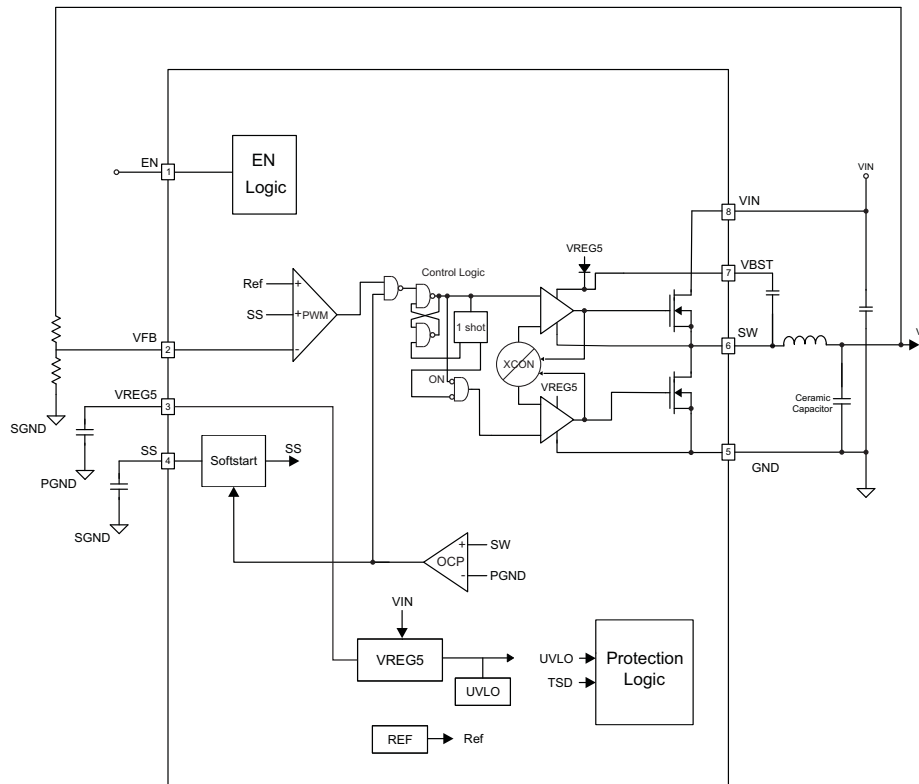

7.3 Feature Description

7.3.1 PWM Operation

The main control loop of the TPS54227 is an adaptive ON-time pulse width modulation (PWM) controller that supports a proprietary D-CAP2 mode control. D-CAP2 mode control combines constant ON-time control with an internal compensation circuit for pseudo-fixed frequency and low external component count configuration with both low ESR and ceramic output capacitors. It is stable even with virtually no ripple at the output.

At the beginning of each cycle, the high-side MOSFET is turned on. This MOSFET is turned off after internal one shot timer expires. This one shot is set by the converter input voltage, V_{IN} , and the output voltage, V_O , to maintain a pseudo-fixed frequency over the input voltage range, hence it is called adaptive ON-time control. The one-shot timer is reset and the high-side MOSFET is turned on again when the feedback voltage falls below the reference voltage. An internal ramp is added to reference voltage to simulate output ripple, eliminating the need for ESR induced output ripple from D-CAP2 mode control.

Feature Description (continued)

7.3.2 PWM Frequency and Adaptive ON-Time Control

TPS54227 uses an adaptive ON-time control scheme and does not have a dedicated on board oscillator. The TPS54227 runs with a pseudo-constant frequency of 700 kHz by using the input voltage and output voltage to set the ON-time one-shot timer. The ON-time is inversely proportional to the input voltage and proportional to the output voltage, therefore, when the duty ratio is V_{OUT} / V_{IN} , the frequency is constant.

7.3.3 Soft-Start and Prebias Soft-Start

The soft-start function is adjustable. When the EN pin becomes high, 2- μ A current begins charging the capacitor which is connected from the SS pin to GND. Smooth control of the output voltage is maintained during start-up. The equation for the slow start time is shown in Equation 1. VFB voltage is 0.765 V and SS pin source current is 2 μ A.

$$t_{SS}(\text{ms}) = \frac{C6(\text{nF}) \times V_{REF} \times 1.1}{I_{SS}(\mu\text{A})} = \frac{C6(\text{nF}) \times 0.765 \times 1.1}{2} \quad (1)$$

The TPS54227 contains a unique circuit to prevent current from being pulled from the output during start-up if the output is prebiased. When the soft-start commands a voltage higher than the prebias level (internal soft-start becomes greater than feedback voltage V_{FB}), the controller slowly activates synchronous rectification by starting the first low-side FET gate driver pulses with a narrow ON-time. It then increments that ON-time on a cycle-by-cycle basis until it coincides with the time dictated by (1-D), where D is the duty cycle of the converter. This scheme prevents the initial sinking of the prebias output, and ensure that the out voltage (VO) starts and ramps up smoothly into regulation and the control loop is given time to transition from prebiased start-up to normal mode operation.

7.3.4 Current Protection

The output overcurrent protection (OCP) is implemented using a cycle-by-cycle valley detect control circuit. The switch current is monitored by measuring the low-side FET switch voltage between the SW pin and GND. This voltage is proportional to the switch current. To improve accuracy, the voltage sensing is temperature compensated.

During the ON-time of the high-side FET switch, the switch current increases at a linear rate determined by V_{IN} , V_{OUT} , the ON-time and the output inductor value. During the ON-time of the low-side FET switch, this current decreases linearly. The average value of the switch current is the load current I_{OUT} . The TPS54227 constantly monitors the low-side FET switch voltage, which is proportional to the switch current, during the low-side ON-time. If the measured voltage is above the voltage proportional to the current limit, an internal counter is incremented per each SW cycle and the converter maintains the low-side switch on until the measured voltage is below the voltage corresponding to the current limit at which time the switching cycle is terminated and a new switching cycle begins. In subsequent switching cycles, the ON-time is set to a fixed value and the current is monitored in the same manner. If the overcurrent condition exists for 7 consecutive switching cycles, the internal OCL threshold is set to a lower level, reducing the available output current. When a switching cycle occurs where the switch current is not above the lower OCL threshold, the counter is reset and the OCL limit is returned to the higher value.

There are some important considerations for this type of overcurrent protection. The load current one half of the peak-to-peak inductor current higher than the overcurrent threshold. Also when the current is being limited, the output voltage tends to fall as the demanded load current may be higher than the current available from the converter. This may cause the output voltage to fall. When the overcurrent condition is removed, the output voltage returns to the regulated value. This protection is non-latching.

7.3.5 UVLO Protection

Undervoltage lockout protection (UVLO) monitors the voltage of the V_{REG5} pin. When the V_{REG5} voltage is lower than UVLO threshold voltage, the TPS54227 is shut off. This is protection is non-latching.

7.3.6 Thermal Shutdown

TPS54227 monitors the temperature of itself. If the temperature exceeds the threshold value (typically 165°C), the device is shut off. This is non-latch protection.

7.4 Device Functional Modes

7.4.1 Normal Operation

When the input voltage is above the UVLO threshold and the EN voltage is above the enable threshold, the TPS54227 operates in normal switching mode. Normal continuous conduction mode (CCM) occurs when the minimum switch current is above 0 A. In CM the TPS54227 operates at a quasi-fixed frequency of 650 kHz.

7.4.2 Forced CCM Operation

When the TPS54227 is in normal CCM operating mode and the switch current falls below 0 A, the device begins operating in forced CCM.

8 Application and Implementation

NOTE

Information in the following applications sections is not part of the TI component specification, and TI does not warrant its accuracy or completeness. TI's customers are responsible for determining suitability of components for their purposes. Customers should validate and test their design implementation to confirm system functionality.

8.1 Application Information

The TPS54227 is used as a step converter that converts a voltage of 4.5 to 18 V to a lower voltage. WEBENCH™ software is available to aid in the design and analysis of circuits.

8.2 Typical Application

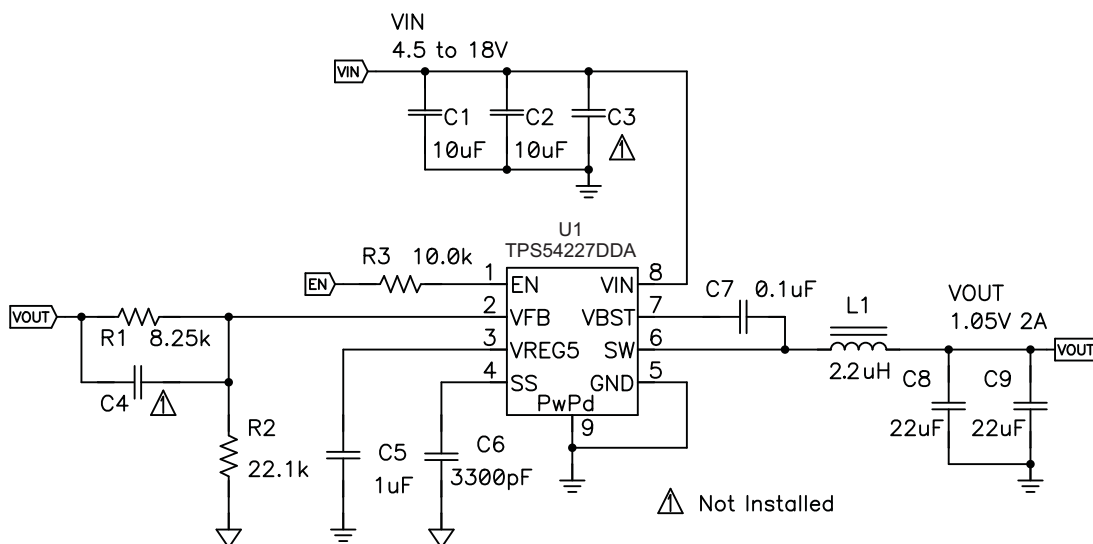

Figure 8. Typical Application

8.2.1 Design Requirements

Table 1 lists the design requirements for this example.

Table 1. Design Requirements

SPECIFICATIONS	TEST CONDITIONS	MIN	TYP	MAX	UNIT
Input voltage		4.5	12	18	V
Output voltage			1.05		V
Operating frequency	$V_{IN} = 12\text{ V}$, $I_o = 1\text{ A}$		700		kHz
Output current range		0		12	A

8.2.2 Detailed Design Procedure

To begin the design process, you must know a few application parameters:

- Input voltage range
- Output voltage
- Output current
- Output voltage ripple
- Input voltage ripple

8.2.2.1 Output Voltage Resistors Selection

The output voltage is set with a resistor divider from the output node to the VFB pin. TI recommends to use 1% tolerance or better divider resistors. Start by using [Equation 2](#) to calculate V_{OUT} .

To improve efficiency at very light loads consider using larger value resistors, too high of resistance is more susceptible to noise and voltage errors from the VFB input current is more noticeable.

$$V_{OUT} = 0.765 \times \left(1 + \frac{R1}{R2} \right) \quad (2)$$

8.2.2.2 Output Filter Selection

The output filter used with the TPS54227 is an LC circuit. This LC filter has double pole at:

$$F_P = \frac{1}{2\pi\sqrt{L_{OUT} \times C_{OUT}}} \quad (3)$$

At low frequencies, the overall loop gain is set by the output set-point resistor divider network and the internal gain of the TPS54227. The low frequency phase is 180 degrees. At the output filter pole frequency, the gain rolls off at a –40 dB per decade rate and the phase drops rapidly. D-CAP2 introduces a high frequency zero that reduces the gain roll off to –20 dB per decade and increases the phase to 90 degrees one decade above the zero frequency. The inductor and capacitor selected for the output filter must be selected so that the double pole of [Equation 3](#) is located below the high frequency zero but close enough that the phase boost provided by the high frequency zero provides adequate phase margin for a stable circuit. To meet this requirement use the values recommended in [Table 2](#).

Table 2. Recommended Component Values

Output Voltage (V)	R1 (kΩ)	R2 (kΩ)	C4 (pF) ⁽¹⁾	L1 (μH)	C8 + C9 (μF)
1	6.81	22.1		1.5 - 2.2	22 - 68
1.05	8.25	22.1		1.5 - 2.2	22 - 68
1.2	12.7	22.1		2.2	22 - 68
1.5	21.5	22.1		2.2	22 - 68
1.8	30.1	22.1	5 - 22	3.3	22 - 68
2.5	49.9	22.1	5 - 22	3.3	22 - 68
3.3	73.2	22.1	5 - 22	3.3	22 - 68
5	124	22.1	5 - 22	4.7	22 - 68
6.5	165	22.1	5 - 22	4.7	22 - 68

(1) Optional

Because the DC gain is dependent on the output voltage, the required inductor value increases as the output voltage increases. For higher output voltages at or above 1.8 V, additional phase boost can be achieved by adding a feed forward capacitor (C4) in parallel with R1

The inductor peak-to-peak ripple current, peak current and RMS current are calculated using [Equation 4](#), [Equation 5](#) and [Equation 6](#). The inductor saturation current rating must be greater than the calculated peak current and the RMS or heating current rating must be greater than the calculated RMS current. Use 700 kHz for f_{SW} .

Use 700 kHz for f_{SW} . Make sure the chosen inductor is rated for the peak current of [Equation 5](#) and the RMS current of [Equation 6](#).

$$I_{IPP} = \frac{V_{OUT}}{V_{IN(max)}} \times \frac{V_{IN(max)} - V_{OUT}}{L_O \times f_{SW}} \tag{4}$$

$$I_{Ipeak} = I_O + \frac{I_{Ipp}}{2} \tag{5}$$

$$I_{Lo(RMS)} = \sqrt{I_O^2 + \frac{1}{12} I_{IPP}^2} \tag{6}$$

For this design example, the calculated peak current is 2.311 A and the calculated RMS current is 2.008 A. The inductor used is a TDK CLF7045T-2R2M with a peak current rating of 5.5 A and an RMS current rating of 4.3 A.

The capacitor value and ESR determines the amount of output voltage ripple. The TPS54227 is intended for use with ceramic or other low ESR capacitors. Recommended values range from 22 µF to 68 µF. Use Equation 7 to determine the required RMS current rating for the output capacitor.

$$I_{Co(RMS)} = \frac{V_{OUT} \times (V_{IN} - V_{OUT})}{\sqrt{12} \times V_{IN} \times L_O \times f_{SW}} \tag{7}$$

For this design two TDK C3216X5R0J226M 22-µF output capacitors are used. The typical ESR is 2 mΩ each. The calculated RMS current is 0.18 A and each output capacitor is rated for 4A.

8.2.2.3 Input Capacitor Selection

The TPS54227 requires an input decoupling capacitor and a bulk capacitor is needed depending on the application. A ceramic capacitor over 10 µF is recommended for the decoupling capacitor. An additional 0.1-µF capacitor (C3) from pin 8 to ground is optional to provide additional high frequency filtering. The capacitor voltage rating needs to be greater than the maximum input voltage.

8.2.2.4 Bootstrap Capacitor Selection

A 0.1-µF ceramic capacitor must be connected between the VBST to SW pin for proper operation. TI recommends to use a ceramic capacitor.

8.2.2.5 VREG5 Capacitor Selection

A 1-µF ceramic capacitor must be connected between the VREG5 to GND pin for proper operation. TI recommends to use a ceramic capacitor.

8.2.3 Application Curves

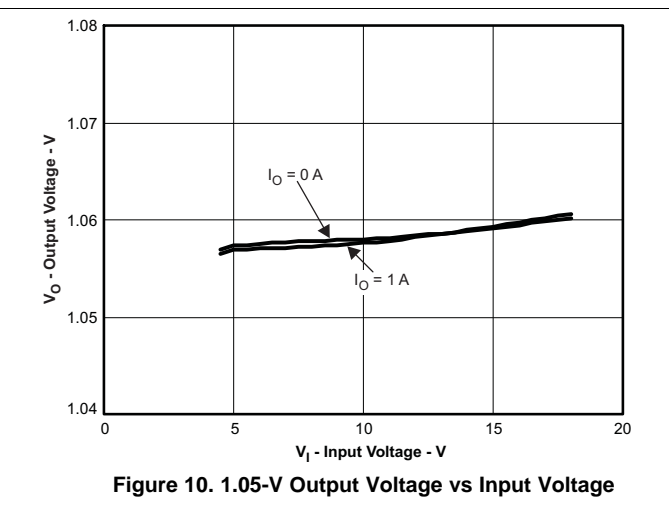
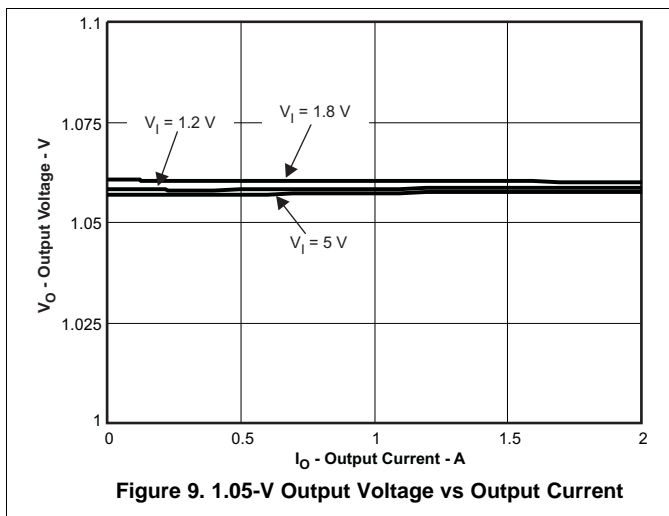

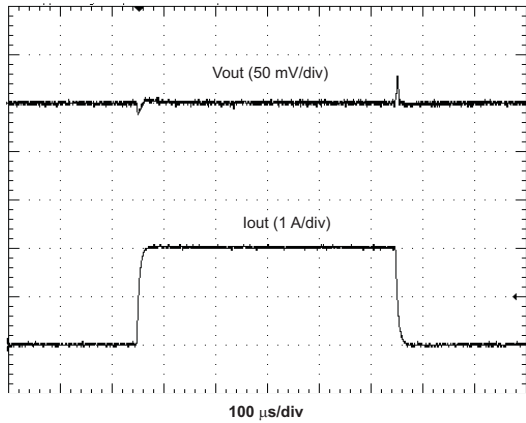

Figure 11. 1.05-V, 0-A to 2-A Load Transient Response

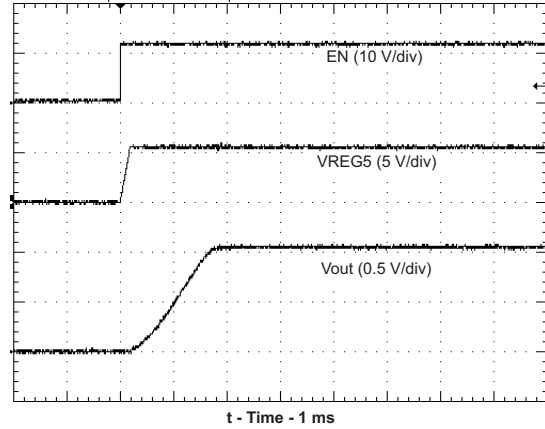

Figure 12. Start-Up Waveform

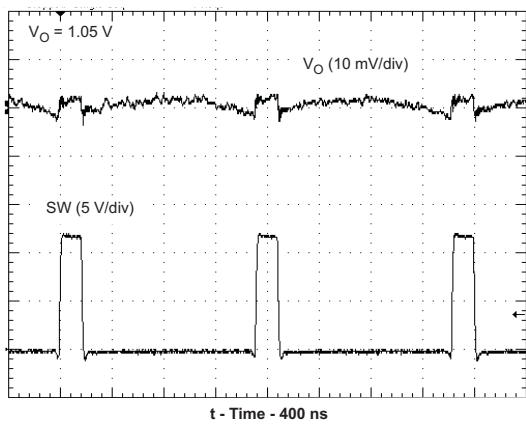

Figure 13. Voltage Ripple at Output ($I_O = 2\text{ A}$)

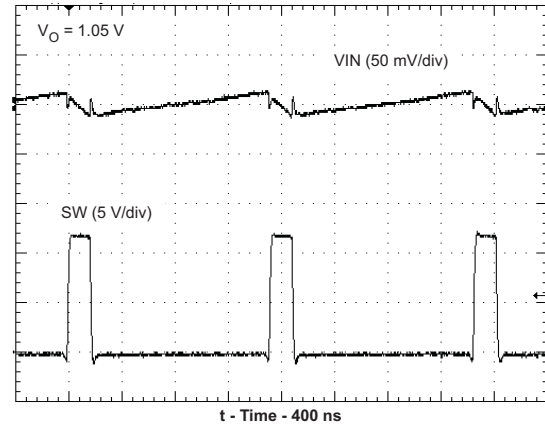

Figure 14. Voltage Ripple at Output ($I_O = 2\text{ A}$)

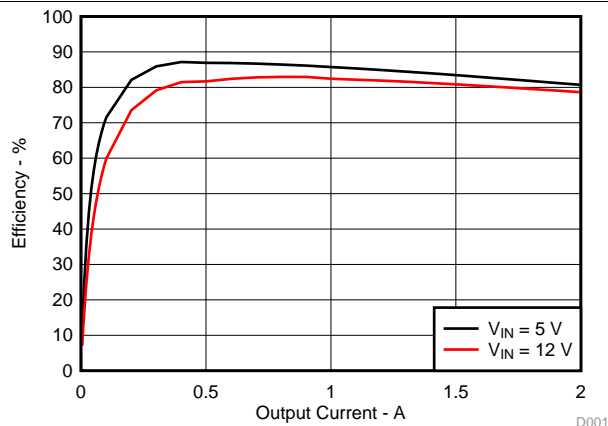

Figure 15. TPS54227EVM-686 Efficiency

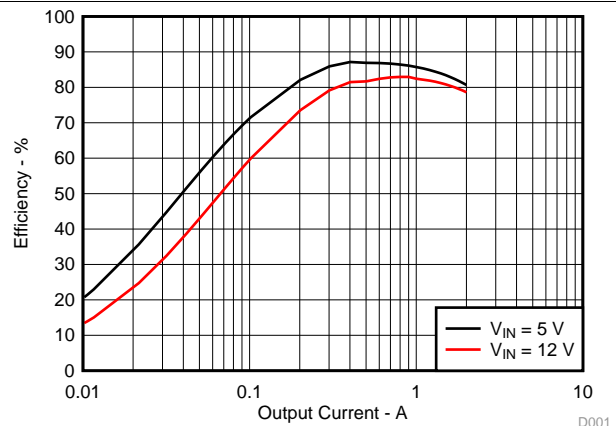

Figure 16. TPS54227EVM-686 Light Load Efficiency

9 Power Supply Recommendations

The TPS54227 is designed to operate from input supply voltage in the range of 4.5 V to 18 V. Buck converters require the input voltage to be higher than the output voltage.

10 Layout

10.1 Layout Guidelines

1. Keep the input switching current loop as small as possible.
2. Keep the SW node as physically small and short as possible to minimize parasitic capacitance and inductance and to minimize radiated emissions. Kelvin connections should be brought from the output to the feedback pin of the device.
3. Keep analog and non-switching components away from switching components.
4. Make a single point connection from the signal ground to power ground.
5. Do not allow switching current to flow under the device.
6. Keep the pattern lines for VIN and PGND broad.
7. Exposed pad of device must be connected to PGND with solder.
8. VREG5 capacitor should be placed near the device, and connected PGND.
9. Output capacitor should be connected to a broad pattern of the PGND.
10. Voltage feedback loop should be as short as possible, and preferably with ground shield.
11. Lower resistor of the voltage divider which is connected to the VFB pin should be tied to SGND.
12. Providing sufficient via is preferable for VIN, SW and PGND connection.
13. PCB pattern for VIN, SW, and PGND should be as broad as possible.
14. VIN Capacitor should be placed as near as possible to the device.

10.2 Layout Examples

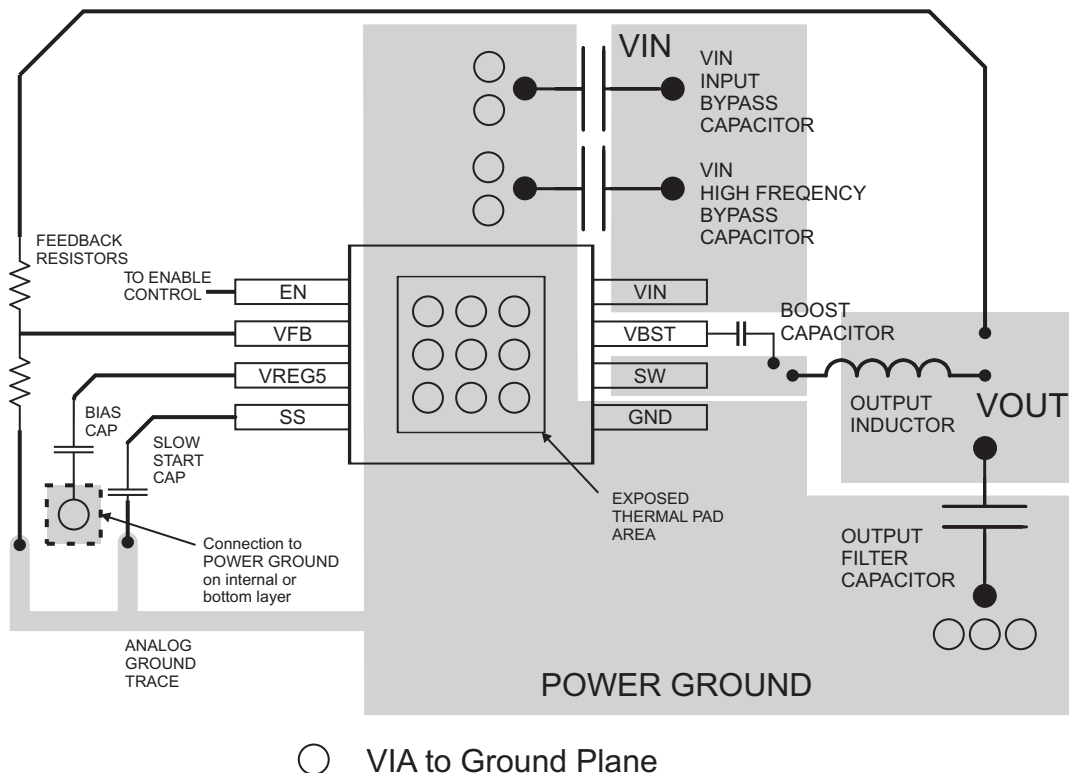
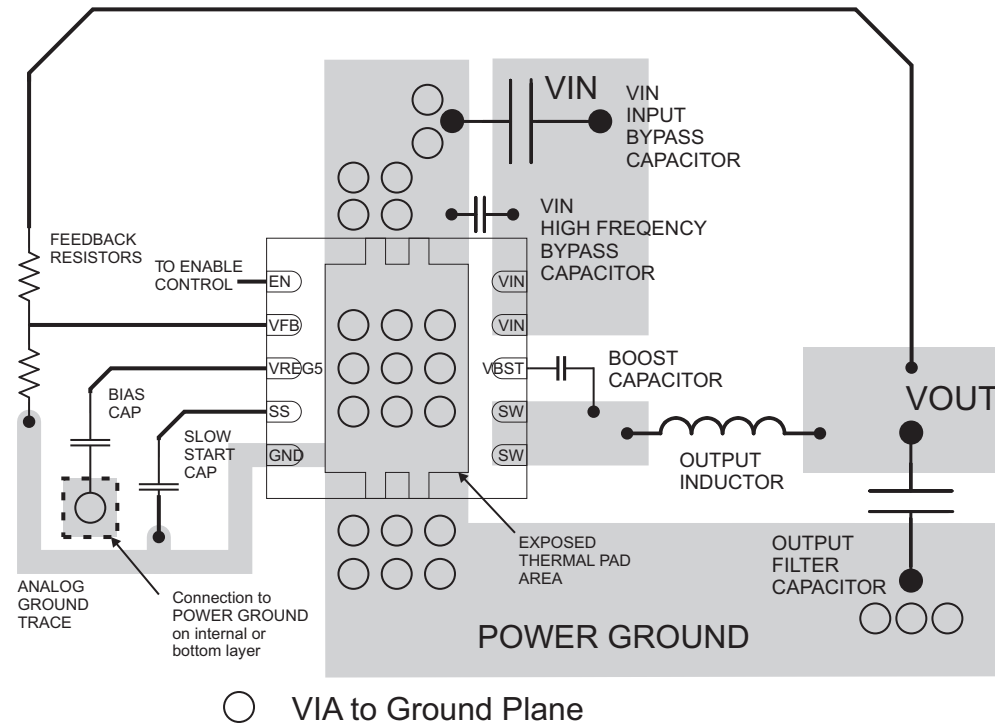

Figure 17. PCB Layout for the DDA Package

Layout Examples (continued)



○ VIA to Ground Plane
Figure 18. PCB Layout for the DRC Package

10.3 Thermal Considerations

This 8-pin HSOP package incorporates an exposed thermal pad that is designed to be directly to an external heatsink. The thermal pad must be soldered directly to the printed-circuit-board (PCB). After soldering, the PCB can be used as a heatsink. In addition, through the use of thermal vias, the thermal pad can be attached directly to the appropriate copper plane shown in the electrical schematic for the device, or alternatively, can be attached to a special heatsink structure designed into the PCB. This design optimizes the heat transfer from the integrated circuit (IC).

For additional information on the exposed thermal pad and how to use the advantage of its heat dissipating abilities, refer to *PowerPAD™ Thermally Enhanced Package (SLMA002)* and *PowerPAD™ Made Easy (SLMA004)*.

The exposed thermal pad dimensions for this package are shown in [Figure 19](#).

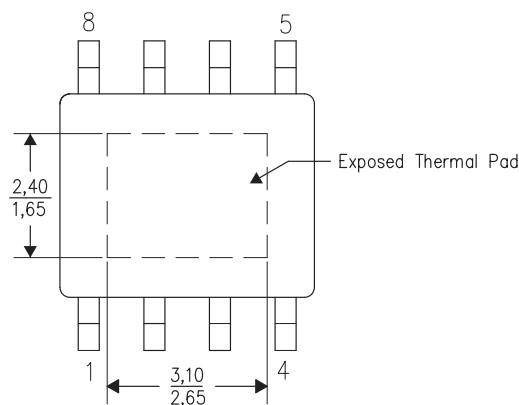

Figure 19. Thermal Pad Dimensions (Top View)

11 Device and Documentation Support

11.1 Documentation Support

11.1.1 Related Documentation

For related documentation see the following:

- *PowerPAD™ Thermally Enhanced Package*, [SLMA002](#)
- *PowerPAD™ Made Easy*, [SLMA004](#)

11.2 Community Resources

The following links connect to TI community resources. Linked contents are provided "AS IS" by the respective contributors. They do not constitute TI specifications and do not necessarily reflect TI's views; see TI's [Terms of Use](#).

TI E2E™ Online Community *TI's Engineer-to-Engineer (E2E) Community*. Created to foster collaboration among engineers. At [e2e.ti.com](#), you can ask questions, share knowledge, explore ideas and help solve problems with fellow engineers.

Design Support *TI's Design Support* Quickly find helpful E2E forums along with design support tools and contact information for technical support.

11.3 Trademarks

D-CAP2, WEBENCH, PowerPAD, E2E are trademarks of Texas Instruments.
Blu-ray Disc is a trademark of Blu-ray Disc Association.
All other trademarks are the property of their respective owners.

11.4 Electrostatic Discharge Caution



These devices have limited built-in ESD protection. The leads should be shorted together or the device placed in conductive foam during storage or handling to prevent electrostatic damage to the MOS gates.

11.5 Glossary

[SLYZ022](#) — *TI Glossary*.

This glossary lists and explains terms, acronyms, and definitions.

12 Mechanical, Packaging, and Orderable Information

The following pages include mechanical, packaging, and orderable information. This information is the most current data available for the designated devices. This data is subject to change without notice and revision of this document. For browser-based versions of this data sheet, refer to the left-hand navigation.

PACKAGING INFORMATION

Orderable Device	Status (1)	Package Type	Package Drawing	Pins	Package Qty	Eco Plan (2)	Lead finish/ Ball material (6)	MSL Peak Temp (3)	Op Temp (°C)	Device Marking (4/5)	Samples
TPS54227DDA	ACTIVE	SO PowerPAD	DDA	8	75	RoHS & Green	NIPDAU SN	Level-2-260C-1 YEAR	-40 to 85	54227	Samples
TPS54227DDAR	ACTIVE	SO PowerPAD	DDA	8	2500	RoHS & Green	NIPDAU SN	Level-2-260C-1 YEAR	-40 to 85	54227	Samples
TPS54227DRCR	ACTIVE	VSON	DRC	10	3000	RoHS & Green	NIPDAU	Level-2-260C-1 YEAR	-40 to 85	54227	Samples
TPS54227DRCT	ACTIVE	VSON	DRC	10	250	RoHS & Green	NIPDAU	Level-2-260C-1 YEAR	-40 to 85	54227	Samples

(1) The marketing status values are defined as follows:

ACTIVE: Product device recommended for new designs.

LIFEBUY: TI has announced that the device will be discontinued, and a lifetime-buy period is in effect.

NRND: Not recommended for new designs. Device is in production to support existing customers, but TI does not recommend using this part in a new design.

PREVIEW: Device has been announced but is not in production. Samples may or may not be available.

OBSOLETE: TI has discontinued the production of the device.

(2) **RoHS:** TI defines "RoHS" to mean semiconductor products that are compliant with the current EU RoHS requirements for all 10 RoHS substances, including the requirement that RoHS substance do not exceed 0.1% by weight in homogeneous materials. Where designed to be soldered at high temperatures, "RoHS" products are suitable for use in specified lead-free processes. TI may reference these types of products as "Pb-Free".

RoHS Exempt: TI defines "RoHS Exempt" to mean products that contain lead but are compliant with EU RoHS pursuant to a specific EU RoHS exemption.

Green: TI defines "Green" to mean the content of Chlorine (Cl) and Bromine (Br) based flame retardants meet JS709B low halogen requirements of <=1000ppm threshold. Antimony trioxide based flame retardants must also meet the <=1000ppm threshold requirement.

(3) MSL, Peak Temp. - The Moisture Sensitivity Level rating according to the JEDEC industry standard classifications, and peak solder temperature.

(4) There may be additional marking, which relates to the logo, the lot trace code information, or the environmental category on the device.

(5) Multiple Device Markings will be inside parentheses. Only one Device Marking contained in parentheses and separated by a "-" will appear on a device. If a line is indented then it is a continuation of the previous line and the two combined represent the entire Device Marking for that device.

(6) Lead finish/Ball material - Orderable Devices may have multiple material finish options. Finish options are separated by a vertical ruled line. Lead finish/Ball material values may wrap to two lines if the finish value exceeds the maximum column width.

Important Information and Disclaimer:The information provided on this page represents TI's knowledge and belief as of the date that it is provided. TI bases its knowledge and belief on information provided by third parties, and makes no representation or warranty as to the accuracy of such information. Efforts are underway to better integrate information from third parties. TI has taken and

continues to take reasonable steps to provide representative and accurate information but may not have conducted destructive testing or chemical analysis on incoming materials and chemicals. TI and TI suppliers consider certain information to be proprietary, and thus CAS numbers and other limited information may not be available for release.

In no event shall TI's liability arising out of such information exceed the total purchase price of the TI part(s) at issue in this document sold by TI to Customer on an annual basis.

TAPE AND REEL INFORMATION

QUADRANT ASSIGNMENTS FOR PIN 1 ORIENTATION IN TAPE



*All dimensions are nominal

Device	Package Type	Package Drawing	Pins	SPQ	Reel Diameter (mm)	Reel Width W1 (mm)	A0 (mm)	B0 (mm)	K0 (mm)	P1 (mm)	W (mm)	Pin1 Quadrant
TPS54227DDAR	SO Power PAD	DDA	8	2500	330.0	12.8	6.4	5.2	2.1	8.0	12.0	Q1
TPS54227DRCR	VSON	DRC	10	3000	330.0	12.4	3.3	3.3	1.1	8.0	12.0	Q2
TPS54227DRCT	VSON	DRC	10	250	180.0	12.4	3.3	3.3	1.1	8.0	12.0	Q2

TAPE AND REEL BOX DIMENSIONS

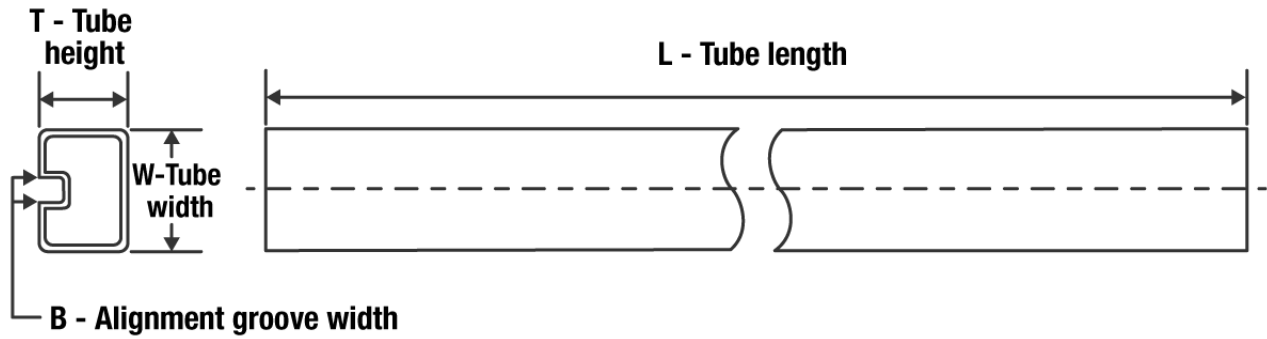

*All dimensions are nominal

Device	Package Type	Package Drawing	Pins	SPQ	Length (mm)	Width (mm)	Height (mm)
TPS54227DDAR	SO PowerPAD	DDA	8	2500	366.0	364.0	50.0
TPS54227DRCR	VSON	DRC	10	3000	367.0	367.0	35.0
TPS54227DRCT	VSON	DRC	10	250	210.0	185.0	35.0

TUBE

*All dimensions are nominal

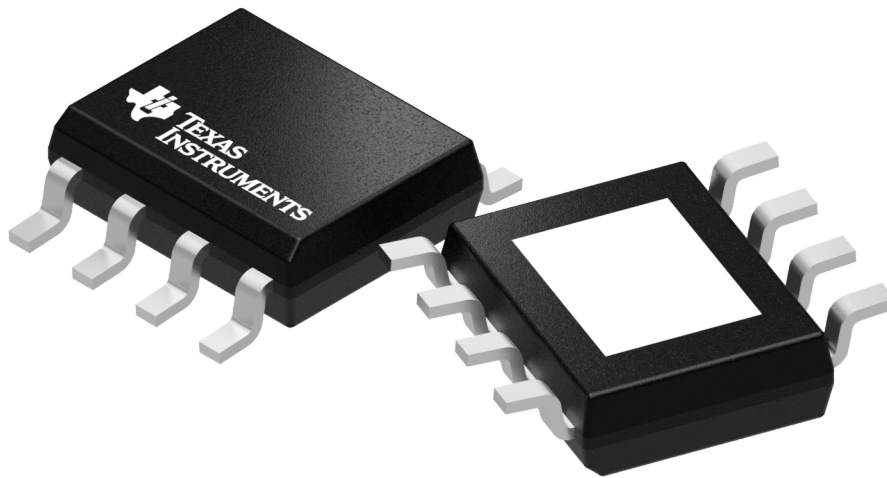
Device	Package Name	Package Type	Pins	SPQ	L (mm)	W (mm)	T (μm)	B (mm)
TPS54227DDA	DDA	HSOIC	8	75	517	7.87	635	4.25
TPS54227DDA	DDA	HSOIC	8	75	508	7.77	2540	NA



Images above are just a representation of the package family, actual package may vary.
Refer to the product data sheet for package details.

DDA (R-PDSO-G8)

PowerPAD™ PLASTIC SMALL-OUTLINE

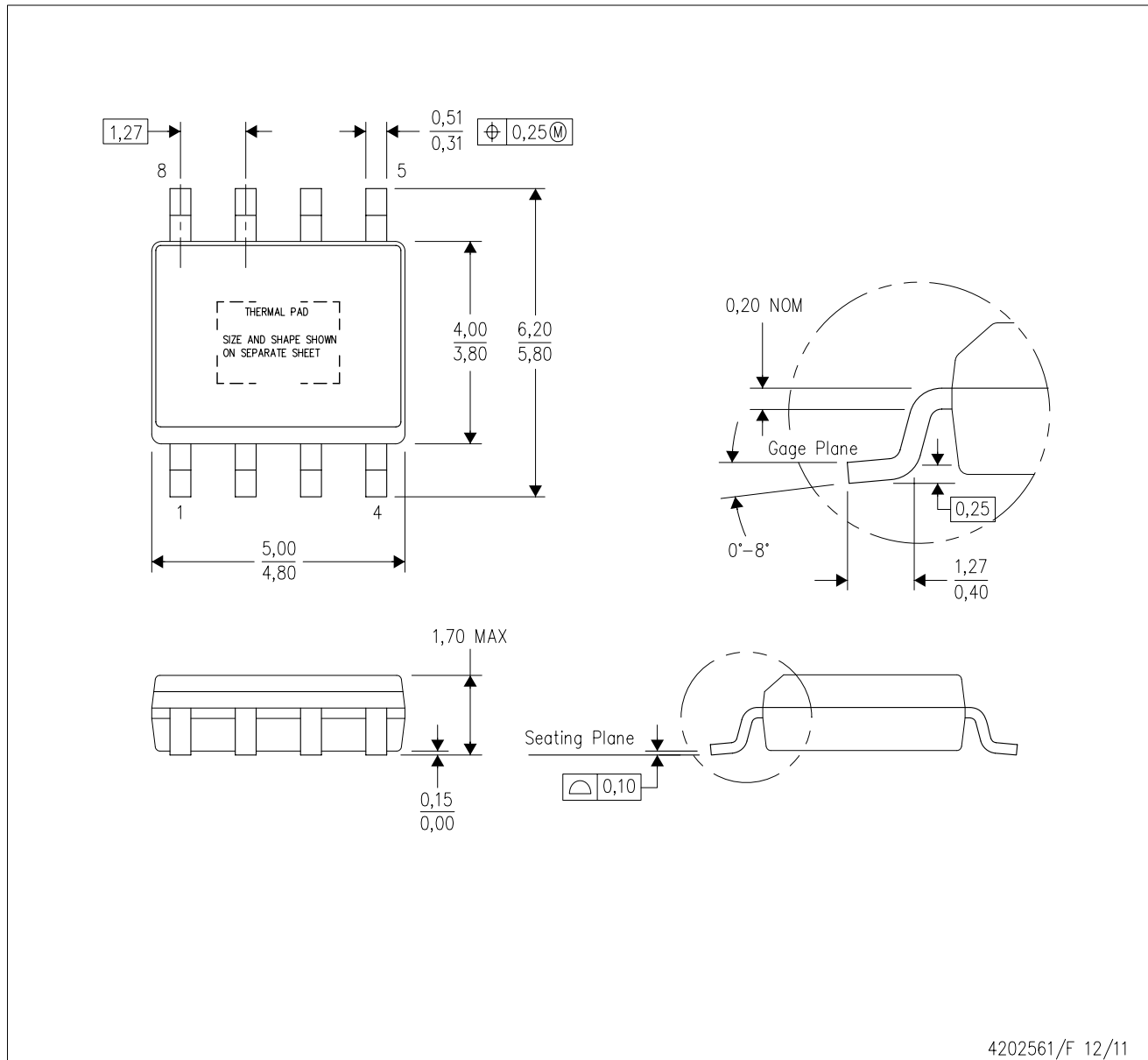

- NOTES:
- A. All linear dimensions are in millimeters. Dimensioning and tolerancing per ASME Y14.5-1994.
 - B. This drawing is subject to change without notice.
 - C. Body dimensions do not include mold flash or protrusion not to exceed 0,15.
 - D. This package is designed to be soldered to a thermal pad on the board. Refer to Technical Brief, PowerPad Thermally Enhanced Package, Texas Instruments Literature No. SLMA002 for information regarding recommended board layout. This document is available at www.ti.com <<http://www.ti.com>>.
 - E. See the additional figure in the Product Data Sheet for details regarding the exposed thermal pad features and dimensions.
 - F. This package complies to JEDEC MS-012 variation BA

PowerPAD is a trademark of Texas Instruments.

DDA (R-PDSO-G8)

PowerPAD™ PLASTIC SMALL OUTLINE

THERMAL INFORMATION

This PowerPAD™ package incorporates an exposed thermal pad that is designed to be attached to a printed circuit board (PCB). The thermal pad must be soldered directly to the PCB. After soldering, the PCB can be used as a heatsink. In addition, through the use of thermal vias, the thermal pad can be attached directly to the appropriate copper plane shown in the electrical schematic for the device, or alternatively, can be attached to a special heatsink structure designed into the PCB. This design optimizes the heat transfer from the integrated circuit (IC).

For additional information on the PowerPAD package and how to take advantage of its heat dissipating abilities, refer to Technical Brief, PowerPAD Thermally Enhanced Package, Texas Instruments Literature No. SLMA002 and Application Brief, PowerPAD Made Easy, Texas Instruments Literature No. SLMA004. Both documents are available at www.ti.com.

The exposed thermal pad dimensions for this package are shown in the following illustration.

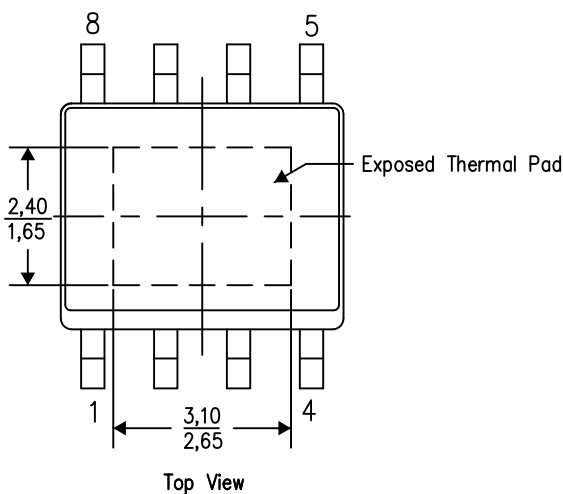

Exposed Thermal Pad Dimensions

4206322-6/L 05/12

NOTE: A. All linear dimensions are in millimeters

PowerPAD is a trademark of Texas Instruments

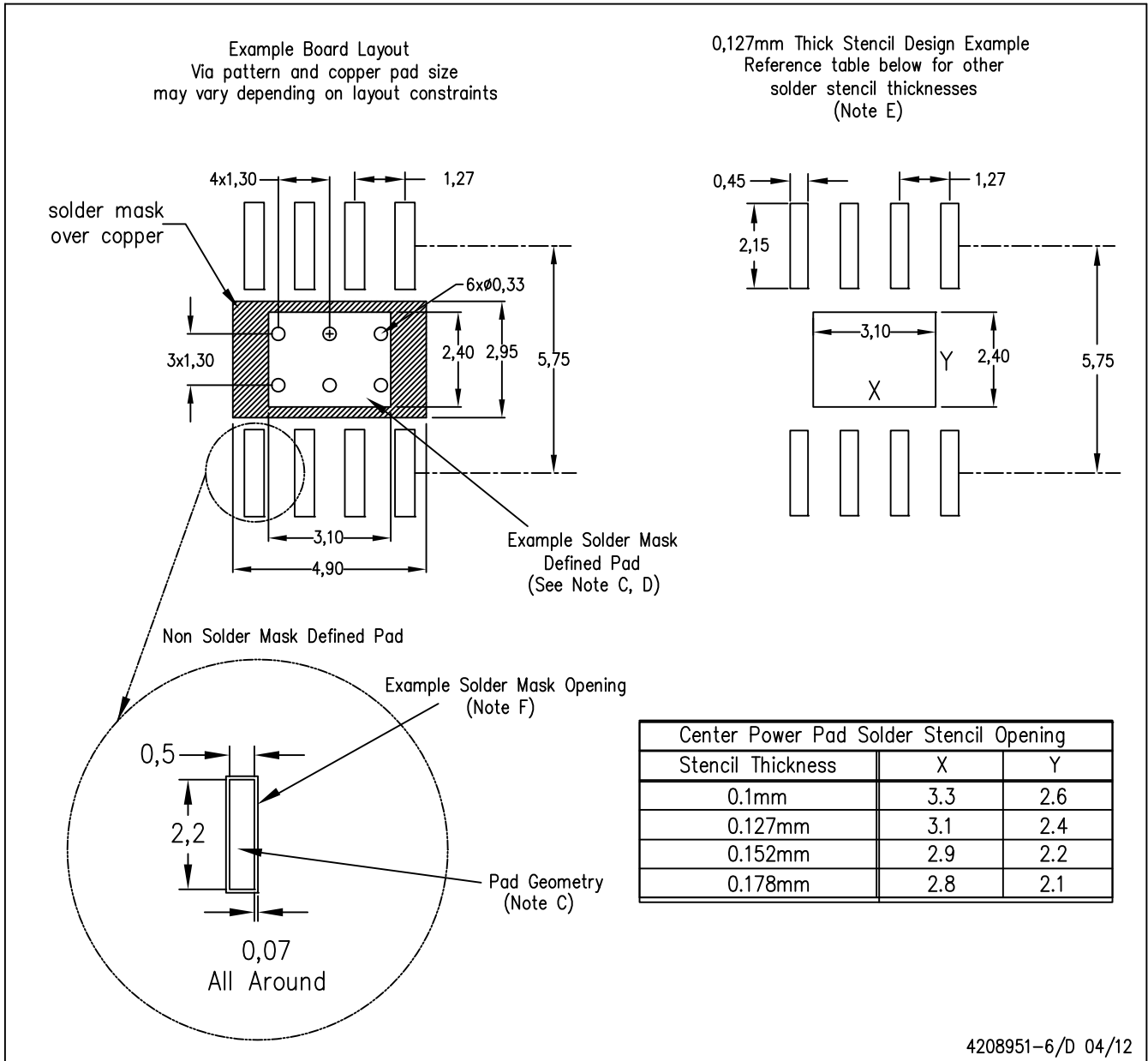

- NOTES:
- A. All linear dimensions are in millimeters.
 - B. This drawing is subject to change without notice.
 - C. Publication IPC-7351 is recommended for alternate designs.
 - D. This package is designed to be soldered to a thermal pad on the board. Refer to Technical Brief, PowerPad Thermally Enhanced Package, Texas Instruments Literature No. SLMA002, SLMA004, and also the Product Data Sheets for specific thermal information, via requirements, and recommended board layout. These documents are available at www.ti.com <<http://www.ti.com>>. Publication IPC-7351 is recommended for alternate designs.
 - E. Laser cutting apertures with trapezoidal walls and also rounding corners will offer better paste release. Customers should contact their board assembly site for stencil design recommendations. Example stencil design based on a 50% volumetric metal load solder paste. Refer to IPC-7525 for other stencil recommendations.
 - F. Customers should contact their board fabrication site for solder mask tolerances between and around signal pads.

PowerPAD is a trademark of Texas Instruments.

GENERIC PACKAGE VIEW

DRC 10

VSON - 1 mm max height

3 x 3, 0.5 mm pitch

PLASTIC SMALL OUTLINE - NO LEAD

This image is a representation of the package family, actual package may vary.
Refer to the product data sheet for package details.

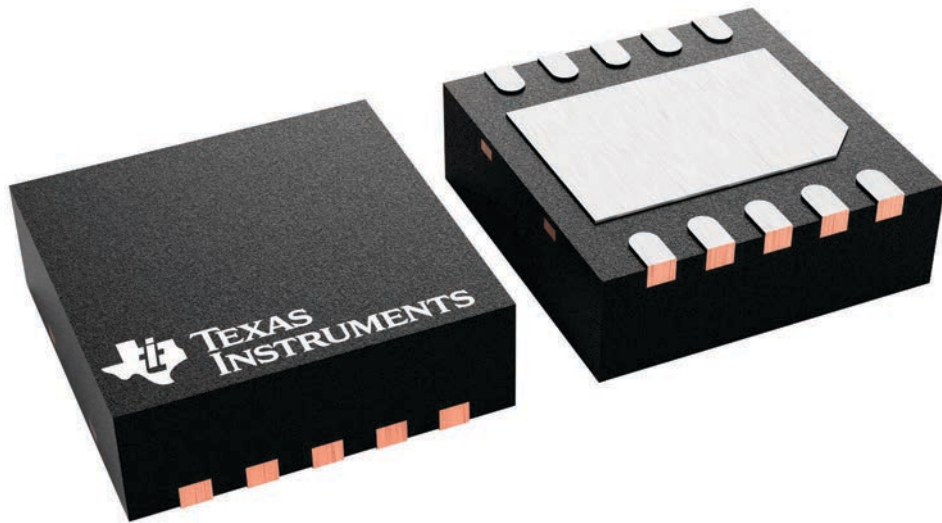

4226193/A

EXAMPLE BOARD LAYOUT

DRC0010J

VSON - 1 mm max height

PLASTIC SMALL OUTLINE - NO LEAD



LAND PATTERN EXAMPLE
EXPOSED METAL SHOWN
SCALE:20X



SOLDER MASK DETAILS

4218878/B 07/2018

NOTES: (continued)

4. This package is designed to be soldered to a thermal pad on the board. For more information, see Texas Instruments literature number SLUA271 (www.ti.com/lit/sluea271).
5. Vias are optional depending on application, refer to device data sheet. If any vias are implemented, refer to their locations shown on this view. It is recommended that vias under paste be filled, plugged or tented.

IMPORTANT NOTICE AND DISCLAIMER

TI PROVIDES TECHNICAL AND RELIABILITY DATA (INCLUDING DATA SHEETS), DESIGN RESOURCES (INCLUDING REFERENCE DESIGNS), APPLICATION OR OTHER DESIGN ADVICE, WEB TOOLS, SAFETY INFORMATION, AND OTHER RESOURCES "AS IS" AND WITH ALL FAULTS, AND DISCLAIMS ALL WARRANTIES, EXPRESS AND IMPLIED, INCLUDING WITHOUT LIMITATION ANY IMPLIED WARRANTIES OF MERCHANTABILITY, FITNESS FOR A PARTICULAR PURPOSE OR NON-INFRINGEMENT OF THIRD PARTY INTELLECTUAL PROPERTY RIGHTS.

These resources are intended for skilled developers designing with TI products. You are solely responsible for (1) selecting the appropriate TI products for your application, (2) designing, validating and testing your application, and (3) ensuring your application meets applicable standards, and any other safety, security, regulatory or other requirements.

These resources are subject to change without notice. TI grants you permission to use these resources only for development of an application that uses the TI products described in the resource. Other reproduction and display of these resources is prohibited. No license is granted to any other TI intellectual property right or to any third party intellectual property right. TI disclaims responsibility for, and you will fully indemnify TI and its representatives against, any claims, damages, costs, losses, and liabilities arising out of your use of these resources.

TI's products are provided subject to [TI's Terms of Sale](#) or other applicable terms available either on ti.com or provided in conjunction with such TI products. TI's provision of these resources does not expand or otherwise alter TI's applicable warranties or warranty disclaimers for TI products.

TI objects to and rejects any additional or different terms you may have proposed.

Mailing Address: Texas Instruments, Post Office Box 655303, Dallas, Texas 75265
Copyright © 2022, Texas Instruments Incorporated