

# 650 kHz/1.2 MHz, 18.5 V 升压型直流(DC)-DC转换器, 此转换器有一个3.2A开关

 查询样品: [TPS61087-Q1](#)

## 特性

- 符合汽车应用要求
- **2.5V 至 6V** 输入电压范围
- 具有 **3.2A** 开关电流的 **18.5V** 升压转换器
- **650kHz/1.2MHz** 可选开关频率
- 可调节软启动
- 热关断
- 欠压锁定
- **10** 引脚方形扁平无引脚(QFN)封装

## 说明

TPS61087-Q1是一款高频, 高效DC到DC转换器, 此转换器含有一个能提供最高为18.5V输出电压的集成3.2A, 0.13Ω电源开关。650kHz或者1.2MHz的可选频率使得此器件可使用小型外部电感器和电容器并提供快速瞬态响应。此外外部补偿可以优化特定条件下的应用。一个连接至软启动引脚的电容器可大大减少启动时的涌入电流。

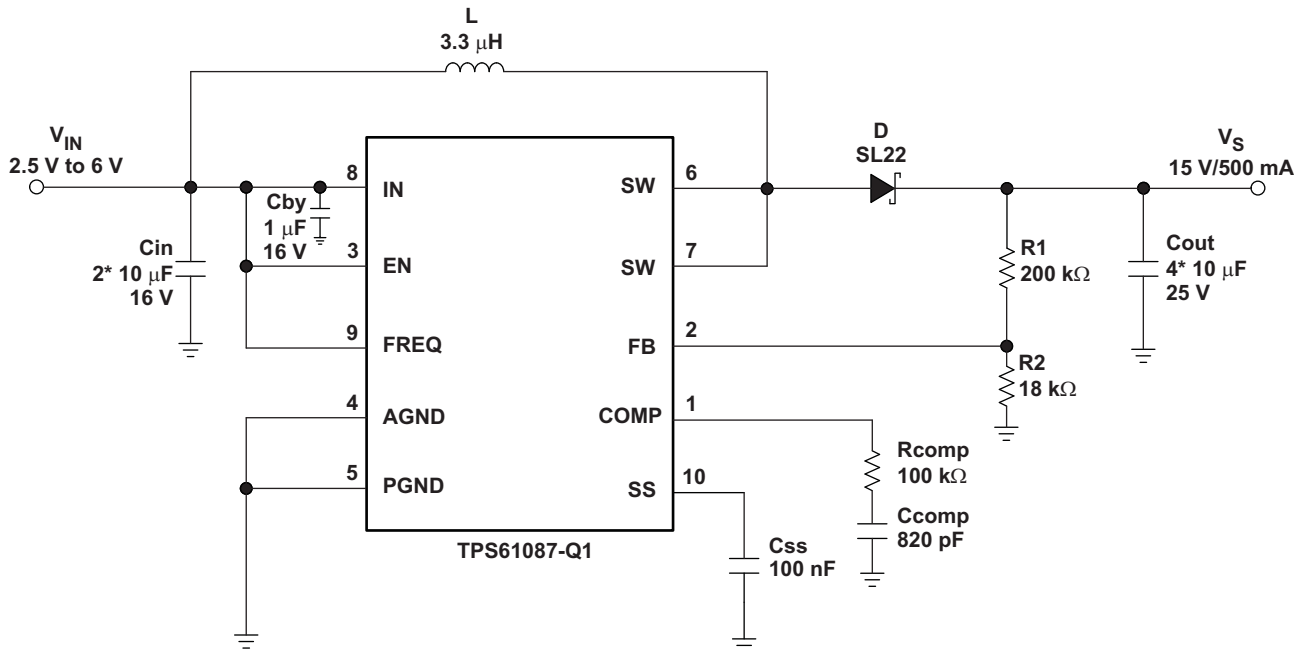

Please be aware that an important notice concerning availability, standard warranty, and use in critical applications of Texas Instruments semiconductor products and disclaimers thereto appears at the end of this data sheet.



These devices have limited built-in ESD protection. The leads should be shorted together or the device placed in conductive foam during storage or handling to prevent electrostatic damage to the MOS gates.

### ORDERING INFORMATION<sup>(1) (2)</sup>

T <sub>A</sub>	PACKAGE		ORDERABLE PART NUMBER	TOP-SIDE MARKING
-40 to 125°C	QFN-10 (DRC)	Reel of 3000	TPS61087QDRCRQ1	PMOQ

- (1) The DRC package is available taped and reeled.  
 (2) For the most current package and ordering information, see the Package Option Addendum at the end of this document, or see the TI website at [www.ti.com](http://www.ti.com).

### ABSOLUTE MAXIMUM RATINGS

over operating free-air temperature range (unless otherwise noted)<sup>(1)</sup>

	VALUE	UNIT
Input voltage range IN <sup>(2)</sup>	-0.3 to 7.0	V
Voltage range on pins EN, FB, SS, FREQ, COMP	-0.3 to 7.0	V
Voltage on pin SW	-0.3 to 20	V
ESD rating HBM	2	kV
ESD rating MM	200	V
ESD rating CDM	1000	V
Continuous power dissipation	See Dissipation Rating Table	
Operating junction temperature range	-40 to 150	°C
Storage temperature range	-65 to 150	°C

- (1) Stresses beyond those listed under *absolute maximum ratings* may cause permanent damage to the device. These are stress ratings only, and functional operation of the device at these or any other conditions beyond those indicated under *recommended operating conditions* is not implied. Exposure to absolute-maximum-rated conditions for extended periods may affect device reliability.  
 (2) All voltage values are with respect to network ground terminal.

### DISSIPATION RATINGS<sup>(1) (2)</sup>

PACKAGE	T <sub>A</sub> ≤ 25°C POWER RATING	T <sub>A</sub> = 70°C POWER RATING	T <sub>A</sub> = 125°C POWER RATING
QFN	1.74 W	0.96 W	0.70 W

- (1)  $P_D = (T_J - T_A) / R_{\theta JA}$ .  
 (2) The exposed thermal die is soldered to the PCB using thermal vias. For more information, see the Texas Instruments Application report [SLMA002](#) regarding thermal characteristics of the PowerPAD package.

### RECOMMENDED OPERATING CONDITIONS

		MIN	TYP	MAX	UNIT
V <sub>IN</sub>	Input voltage range	2.5		6	V
V <sub>S</sub>	Boost output voltage range	V <sub>IN</sub> + 0.5		18.5	V
T <sub>A</sub>	Operating free-air temperature	-40		125	°C

**ELECTRICAL CHARACTERISTICS**
 $V_{IN} = 5\text{ V}$ ,  $EN = V_{IN}$ ,  $V_S = 15\text{ V}$ ,  $T_A = -40^\circ\text{C}$  to  $125^\circ\text{C}$ , typical values are at  $T_A = 25^\circ\text{C}$  (unless otherwise noted)

PARAMETER		TEST CONDITIONS	MIN	TYP	MAX	UNIT
<b>SUPPLY</b>						
$V_{IN}$	Input voltage range		2.5		6	V
$I_Q$	Operating quiescent current into IN	Device not switching, $V_{FB} = 1.3\text{ V}$		75	100	$\mu\text{A}$
$I_{SDVIN}$	Shutdown current into IN	$EN = \text{GND}$			4	$\mu\text{A}$
$V_{UVLO}$	Under-voltage lockout threshold	$V_{IN}$ falling			2.4	V
		$V_{IN}$ rising			2.5	V
$T_{SD}$	Thermal shutdown	Temperature rising		150		$^\circ\text{C}$
$T_{SDHYS}$	Thermal shutdown hysteresis			14		$^\circ\text{C}$
<b>LOGIC SIGNALS EN, FREQ</b>						
$V_{IH}$	High level input voltage	$V_{IN} = 2.5\text{ V}$ to $6.0\text{ V}$	2			V
$V_{IL}$	Low level input voltage	$V_{IN} = 2.5\text{ V}$ to $6.0\text{ V}$			0.5	V
$I_{INLEAK}$	Input leakage current	$EN = \text{FREQ} = \text{GND}$			0.1	$\mu\text{A}$
<b>BOOST CONVERTER</b>						
$V_S$	Boost output voltage		$V_{IN} + 0.5$		18.5	V
$V_{FB}$	Feedback regulation voltage		1.230	1.238	1.250	V
gm	Transconductance error amplifier			107		$\mu\text{A/V}$
$I_{FB}$	Feedback input bias current	$V_{FB} = 1.238\text{ V}$			0.1	$\mu\text{A}$
$r_{DS(on)}$	N-channel MOSFET on-resistance	$V_{IN} = V_{GS} = 5\text{ V}$ , $I_{SW} = \text{current limit}$		0.13	0.18	$\Omega$
		$V_{IN} = V_{GS} = 3\text{ V}$ , $I_{SW} = \text{current limit}$		0.16	0.23	
$I_{SWLEAK}$	SW leakage current	$EN = \text{GND}$ , $V_{SW} = V_{IN} = 6.0\text{ V}$			2	$\mu\text{A}$
$I_{LIM}$	N-Channel MOSFET current limit		3.2	4.0	4.8	A
$I_{SS}$	Soft-start current	$V_{SS} = 1.238\text{ V}$	7	10	13	$\mu\text{A}$
$f_S$	Oscillator frequency	$\text{FREQ} = V_{IN}$	0.9	1.2	1.5	MHz
		$\text{FREQ} = \text{GND}$	480	650	820	kHz
	Line regulation	$V_{IN} = 2.5\text{ V}$ to $6.0\text{ V}$ , $I_{OUT} = 10\text{ mA}$		0.0002		$\%/V$
	Load regulation	$V_{IN} = 5.0\text{ V}$ , $I_{OUT} = 1\text{ mA}$ to $1\text{ A}$		0.11		$\%/A$

## PIN ASSIGNMENT

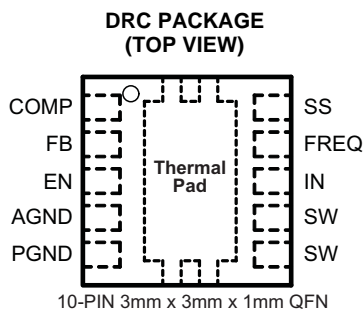

## PIN FUNCTIONS

PIN		I/O	DESCRIPTION
NAME	NO.		
COMP	1	I/O	Compensation pin
FB	2	I	Feedback pin
EN	3	I	Shutdown control input. Connect this pin to logic high level to enable the device
AGND	4, Thermal Pad		Analog ground
PGND	5		Power ground
SW	6, 7		Switch pin
IN	8		Input supply pin
FREQ	9	I	Frequency select pin. The power switch operates at 650 kHz if FREQ is connected to GND and at 1.2 MHz if FREQ is connected to IN
SS	10		Soft-start control pin. Connect a capacitor to this pin if soft-start needed. Open = no soft-start

## TYPICAL CHARACTERISTICS

### TABLE OF GRAPHS

			FIGURE
$I_{OUT(max)}$	Maximum load current	vs. Input voltage at High frequency (1.2 MHz)	Figure 1
$I_{OUT(max)}$	Maximum load current	vs. Input voltage at Low frequency (650 kHz)	Figure 2
$\eta$	Efficiency	vs. Load current, $V_S = 15\text{ V}$ , $V_{IN} = 5\text{ V}$	Figure 3
$\eta$	Efficiency	vs. Load current, $V_S = 9\text{ V}$ , $V_{IN} = 3.3\text{ V}$	Figure 4
	PWM switching - discontinuous conduction		Figure 5
	PWM switching - continuous conduction		Figure 6
	Load transient response	at High frequency (1.2 MHz)	Figure 7
	Load transient response	at Low frequency (650 kHz)	Figure 8
	Soft-start		Figure 9
	Supply current	vs. Supply voltage	Figure 10
	Oscillator frequency	vs. Load current	Figure 11
	Oscillator frequency	vs. Supply voltage	Figure 12

The typical characteristics are measured with the inductors 7447789003 3.3  $\mu\text{H}$  (high frequency) or 74454068 6.8  $\mu\text{H}$  (low frequency) from Würth and the rectifier diode SL22.

TYPICAL CHARACTERISTICS (continued)

MAXIMUM LOAD CURRENT  
vs  
INPUT VOLTAGE

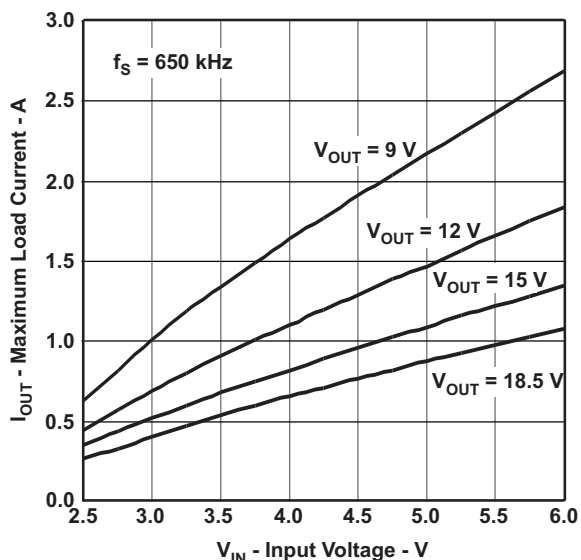

Figure 1.

MAXIMUM LOAD CURRENT  
vs  
INPUT VOLTAGE

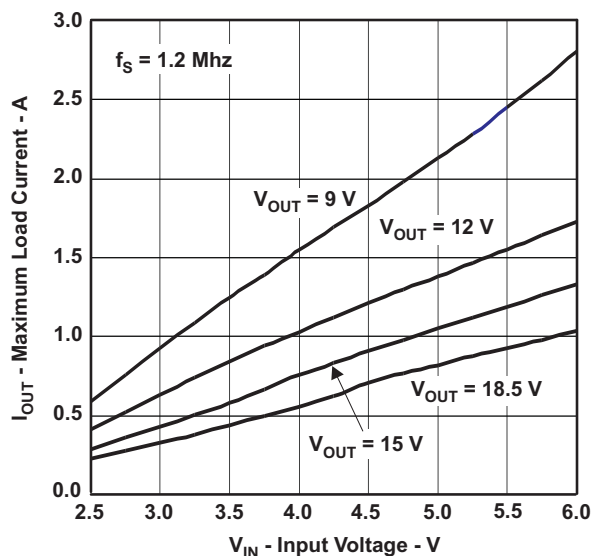

Figure 2.

EFFICIENCY  
vs  
LOAD CURRENT

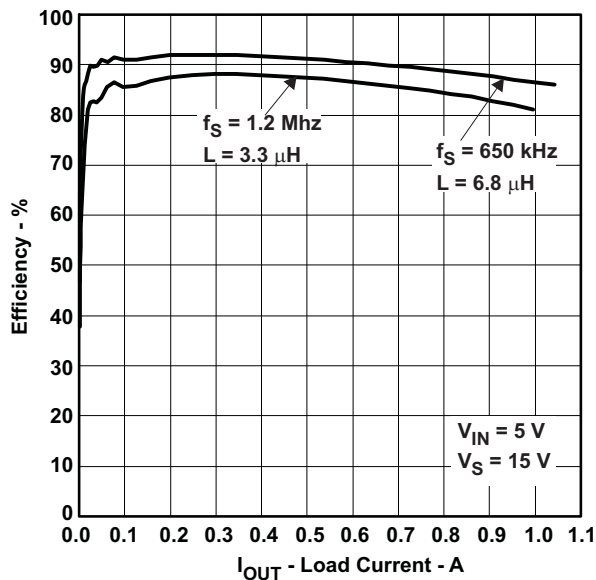

Figure 3.

EFFICIENCY  
vs  
LOAD CURRENT

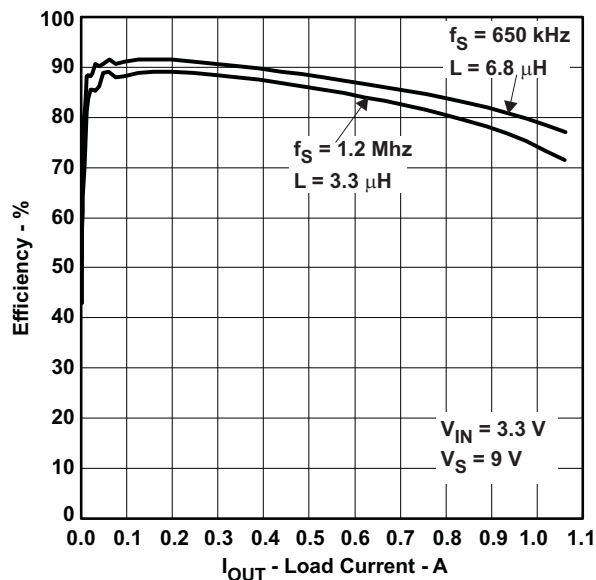

Figure 4.

**TYPICAL CHARACTERISTICS (continued)**

**PWM SWITCHING  
DISCONTINUOUS CONDUCTION MODE**

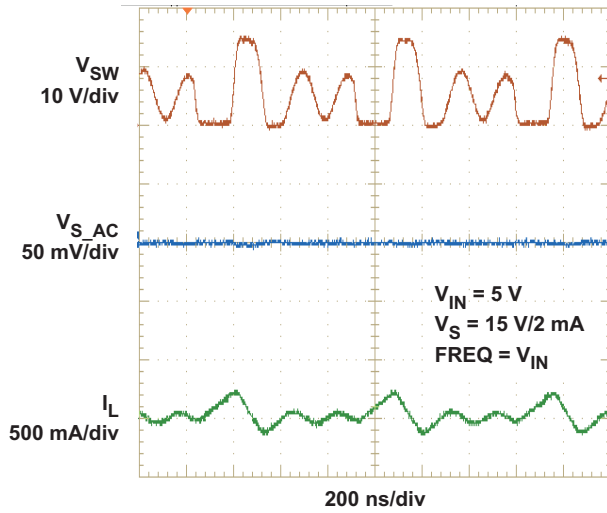

Figure 5.

**PWM SWITCHING  
CONTINUOUS CONDUCTION MODE**

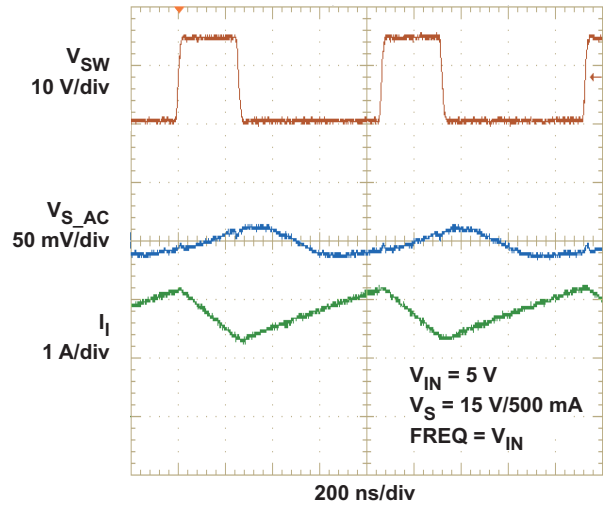

Figure 6.

**LOAD TRANSIENT RESPONSE  
HIGH FREQUENCY (1.2 MHz)**

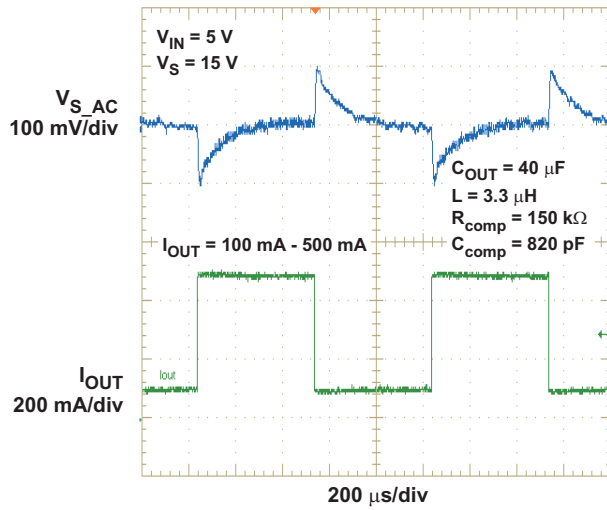

Figure 7.

**LOAD TRANSIENT RESPONSE  
LOW FREQUENCY (650 kHz)**

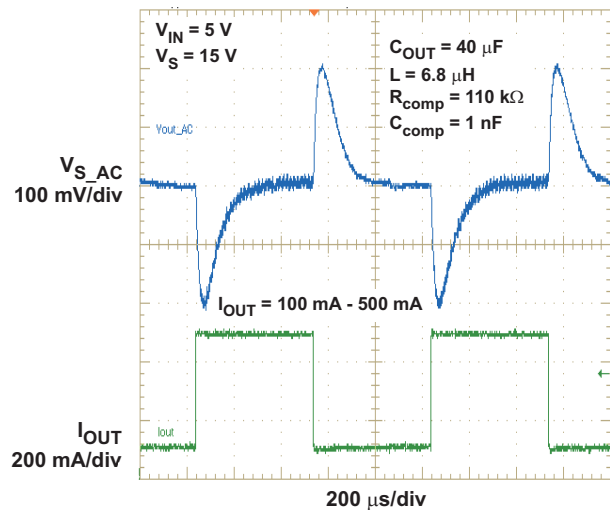

Figure 8.

TYPICAL CHARACTERISTICS (continued)

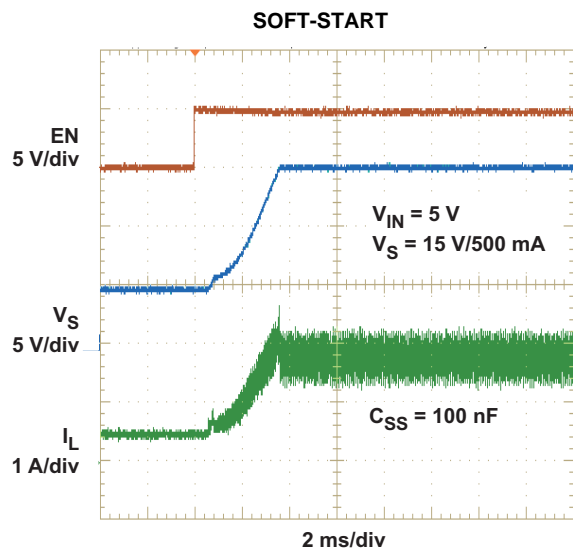

Figure 9.

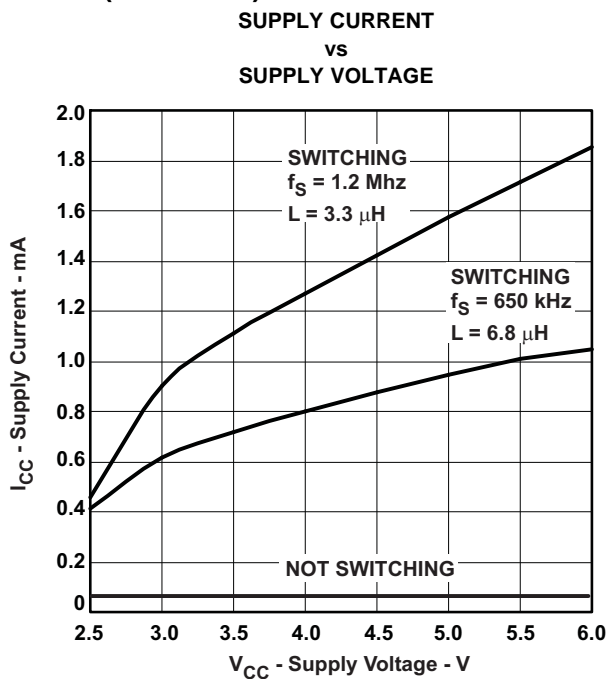

Figure 10.

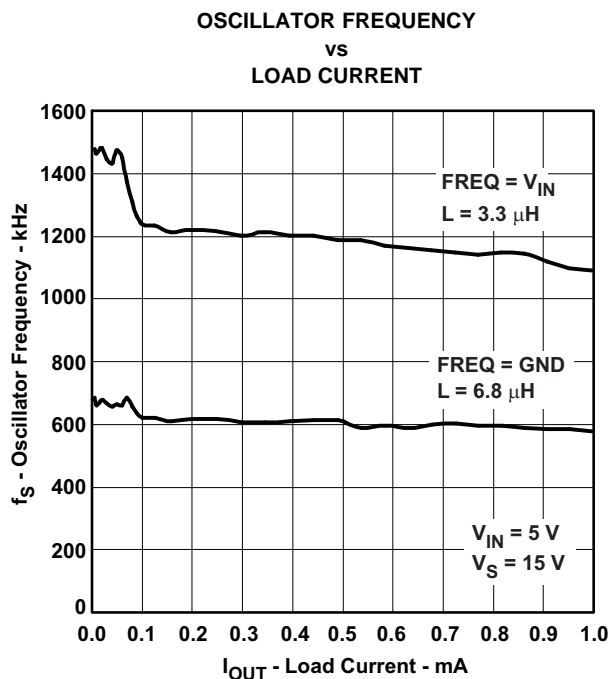

Figure 11.

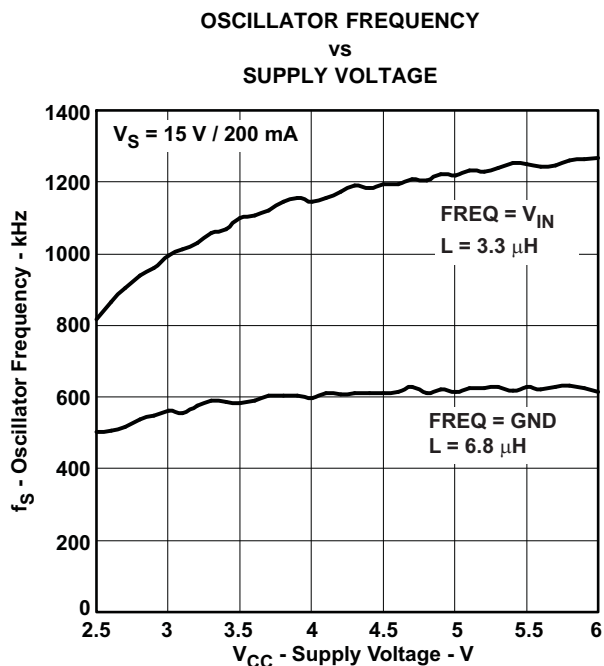

Figure 12.

DETAILED DESCRIPTION

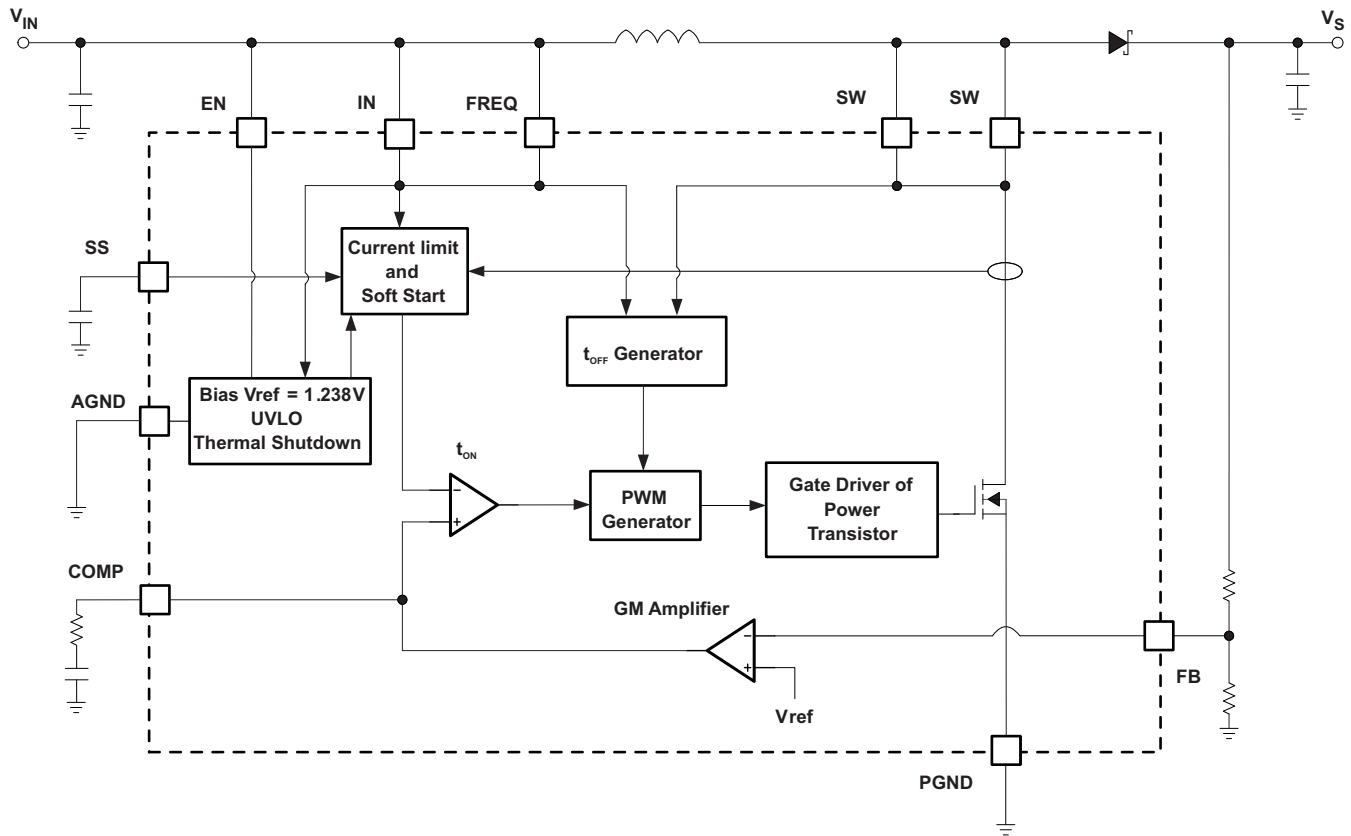

Figure 13. Block Diagram

The boost converter is designed for output voltages up to 18.5 V with a switch peak current limit of 3.2 A minimum. The device, which operates in a current mode scheme with quasi-constant frequency, is externally compensated for maximum flexibility and stability. The switching frequency is selectable between 650 kHz and 1.2 MHz and the minimum input voltage is 2.5 V. To limit the inrush current at start-up a soft-start pin is available.

TPS61087-Q1 boost converter’s novel topology using adaptive off-time provides superior load and line transient responses and operates also over a wider range of applications than conventional converters.

The selectable switching frequency offers the possibility to optimize the design either for the use of small sized components (1.2 MHz) or for higher system efficiency (650 kHz). However, the frequency changes slightly because the voltage drop across the  $r_{DS(on)}$  has some influence on the current and voltage measurement and thus on the on-time (the off-time remains constant).

The converter operates in continuous conduction mode (CCM) as soon as the input current increases above half the ripple current in the inductor, for lower load currents it switches into discontinuous conduction mode (DCM). If the load is further reduced, the part starts to skip pulses to maintain the output voltage.

## Design Procedure

The first step in the design procedure is to verify that the maximum possible output current of the boost converter supports the specific application requirements. A simple approach is to estimate the converter efficiency, by taking the efficiency numbers from the provided efficiency curves or to use a worst case assumption for the expected efficiency, e.g. 90%.

1. Duty cycle,  $D$ :

$$D = 1 - \frac{V_{IN} \cdot \eta}{V_S} \quad (1)$$

2. Maximum output current,  $I_{out(max)}$  :

$$I_{out(max)} = \left( I_{LIM(min)} - \frac{\Delta I_L}{2} \right) \cdot (1 - D) \quad (2)$$

3. Peak switch current in application,  $I_{swpeak}$  :

$$I_{swpeak} = \frac{\Delta I_L}{2} + \frac{I_{out}}{1 - D} \quad (3)$$

with the inductor peak-to-peak ripple current,  $\Delta I_L$

$$\Delta I_L = \frac{V_{IN} \cdot D}{f_S \cdot L} \quad (4)$$

and

$V_{IN}$	Minimum input voltage
$V_S$	Output voltage
$I_{LIM(min)}$	Converter switch current limit (minimum switch current limit = 3.2 A)
$f_S$	Converter switching frequency (typically 1.2 MHz or 650 kHz)
$L$	Selected inductor value
$\eta$	Estimated converter efficiency (please use the number from the efficiency plots or 90% as an estimation)

The peak switch current is the steady state peak switch current that the integrated switch, inductor and external Schottky diode has to be able to handle. The calculation must be done for the minimum input voltage where the peak switch current is the highest.

## Soft-start

The boost converter has an adjustable soft-start to prevent high inrush current during start-up. To minimize the inrush current during start-up an external capacitor, connected to the soft-start pin SS and charged with a constant current, is used to slowly ramp up the internal current limit of the boost converter. When the EN pin is pulled high, the soft-start capacitor  $C_{SS}$  is immediately charged to 0.3 V. The capacitor is then charged at a constant current of 10  $\mu$ A typically until the output of the boost converter  $V_S$  has reached its Power Good threshold (roughly 98% of  $V_S$  nominal value). During this time, the SS voltage directly controls the peak inductor current, starting with 0 A at  $V_{SS} = 0.3$  V up to the full current limit at  $V_{SS} = 800$  mV. The maximum load current is available after the soft-start is completed. The larger the capacitor the slower the ramp of the current limit and the longer the soft-start time. A 100 nF capacitor is usually sufficient for most of the applications. When the EN pin is pulled low, the soft-start capacitor is discharged to ground.

**Inductor Selection**

The TPS61087-Q1 is designed to work with a wide range of inductors. The main parameter for the inductor selection is the saturation current of the inductor which should be higher than the peak switch current as calculated in the *Design Procedure* section with additional margin to cover for heavy load transients. An alternative, more conservative, is to choose an inductor with a saturation current at least as high as the maximum switch current limit of 4.8 A. The other important parameter is the inductor DC resistance. Usually the lower the DC resistance the higher the efficiency. It is important to note that the inductor DC resistance is not the only parameter determining the efficiency. Especially for a boost converter where the inductor is the energy storage element, the type and core material of the inductor influences the efficiency as well. At high switching frequencies of 1.2 MHz inductor core losses, proximity effects and skin effects become more important. Usually an inductor with a larger form factor gives higher efficiency. The efficiency difference between different inductors can vary between 2% to 10%. For the TPS61087-Q1, inductor values between 3 µH and 6 µH are a good choice with a switching frequency of 1.2 MHz, typically 3.3 µH. At 650 kHz we recommend inductors between 6 µH and 13 µH, typically 6.8 µH. Possible inductors are shown in [Table 1](#).

Typically, it is recommended that the inductor current ripple is below 35% of the average inductor current. Therefore, the following equation can be used to calculate the inductor value, *L*:

$$L = \left( \frac{V_{IN}}{V_S} \right)^2 \cdot \left( \frac{V_S - V_{IN}}{I_{out} \cdot f_S} \right) \cdot \left( \frac{\eta}{0.35} \right) \tag{5}$$

with

- V<sub>IN</sub>* Minimum input voltage
- V<sub>S</sub>* Output voltage
- I<sub>out</sub>* Maximum output current in the application
- f<sub>S</sub>* Converter switching frequency (typically 1.2 MHz or 650 kHz)
- η* Estimated converter efficiency (please use the number from the efficiency plots or 90% as an estimation)

**Table 1. Inductor Selection**

L (µH)	SUPPLIER	COMPONENT CODE	SIZE (L×W×H mm)	DCR TYP (mΩ)	I <sub>sat</sub> (A)
<b>1.2 MHz</b>					
4.2	Sumida	CDRH5D28	5.7 × 5.7 × 3	23	2.2
4.7	Würth Elektronik	7447785004	5.9 × 6.2 × 3.3	60	2.5
5	Coilcraft	MSS7341	7.3 × 7.3 × 4.1	24	2.9
5	Sumida	CDRH6D28	7 × 7 × 3	23	2.4
4.6	Sumida	CDR7D28	7.6 × 7.6 × 3	38	3.15
4.7	Würth Elektronik	7447789004	7.3 × 7.3 × 3.2	33	3.9
3.3	Würth Elektronik	7447789003	7.3 × 7.3 × 3.2	30	4.2
<b>650 kHz</b>					
10	Würth Elektronik	744778910	7.3 × 7.3 × 3.2	51	2.2
10	Sumida	CDRH8D28	8.3 × 8.3 × 3	36	2.7
6.8	Sumida	CDRH6D26HPNP	7 × 7 × 2.8	52	2.9
6.2	Sumida	CDRH8D58	8.3 × 8.3 × 6	25	3.3
10	Coilcraft	DS3316P	12.95 × 9.40 × 5.08	80	3.5
10	Sumida	CDRH8D43	8.3 × 8.3 × 4.5	29	4
6.8	Würth Elektronik	74454068	12.7 × 10 × 4.9	55	4.1

### Rectifier Diode Selection

To achieve high efficiency a Schottky type should be used for the rectifier diode. The reverse voltage rating should be higher than the maximum output voltage of the converter. The averaged rectified forward current  $I_{avg}$ , the Schottky diode needs to be rated for, is equal to the output current  $I_{out}$ :

$$I_{avg} = I_{out} \tag{6}$$

Usually a Schottky diode with 2 A maximum average rectified forward current rating is sufficient for most applications. The Schottky rectifier can be selected with lower forward current capability depending on the output current  $I_{out}$  but has to be able to dissipate the power. The dissipated power,  $P_D$ , is the average rectified forward current times the diode forward voltage,  $V_{forward}$ .

$$P_D = I_{avg} \cdot V_{forward} \tag{7}$$

Typically the diode should be able to dissipate around 500mW depending on the load current and forward voltage.

**Table 2. Rectifier Diode Selection**

CURRENT RATING $I_{avg}$	$V_r$	$V_{forward}/I_{avg}$	SUPPLIER	COMPONENT CODE
2 A	20 V	0.44 V / 2 A	Vishay Semiconductor	SL22
2 A	20 V	0.5 V / 2 A	Fairchild Semiconductor	SS22

### Setting the Output Voltage

The output voltage is set by an external resistor divider. Typically, a minimum current of 50  $\mu$ A flowing through the feedback divider gives good accuracy and noise covering. A standard low side resistor of 18 k $\Omega$  is typically selected. The resistors are then calculated as:

$$R2 = \frac{V_{FB}}{70\mu A} \approx 18k\Omega \quad R1 = R2 \cdot \left( \frac{V_s}{V_{FB}} - 1 \right)$$

$$V_{FB} = 1.238V$$

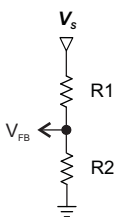

(8)

### Compensation (COMP)

The regulator loop can be compensated by adjusting the external components connected to the COMP pin. The COMP pin is the output of the internal transconductance error amplifier.

Standard values of  $R_{COMP} = 16 k\Omega$  and  $C_{COMP} = 2.7 nF$  will work for the majority of the applications.

See [Table 3](#) for dedicated compensation networks giving an improved load transient response. The following equations can be used to calculate  $R_{COMP}$  and  $C_{COMP}$ :

$$R_{COMP} = \frac{110 \cdot V_{IN} \cdot V_s \cdot C_{out}}{L \cdot I_{out}} \quad C_{COMP} = \frac{V_s \cdot C_{out}}{7.5 \cdot I_{out} \cdot R_{COMP}} \tag{9}$$

with

- $V_{IN}$  Minimum input voltage
- $V_s$  Output voltage
- $C_{out}$  Output capacitance
- $L$  Inductor value, e.g. 3.3  $\mu$ H or 6.8  $\mu$ H
- $I_{out}$  Maximum output current in the application

Make sure that  $R_{COMP} < 120 k\Omega$  and  $C_{COMP} > 820 pF$ , independent of the results of the above formulas.

**Table 3. Recommended Compensation Network Values at High/Low Frequency**

FREQUENCY	L	V <sub>S</sub>	V <sub>IN</sub> ± 20%	R <sub>COMP</sub>	C <sub>COMP</sub>
High (1.2 MHz)	3.3 µH	15 V	5 V	100 kΩ	820 pF
			3.3 V	91 kΩ	1.2 nF
		12 V	5 V	68 kΩ	820 pF
			3.3 V	68 kΩ	1.2 nF
		9 V	5 V	39 kΩ	820 pF
			3.3 V	39 kΩ	1.2 nF
Low (650 kHz)	6.8 µH	15 V	5 V	51 kΩ	1.5 nF
			3.3 V	47 kΩ	2.7 nF
		12 V	5 V	33 kΩ	1.5 nF
			3.3 V	33 kΩ	2.7 nF
		9 V	5 V	18 kΩ	1.5 nF
			3.3 V	18 kΩ	2.7 nF

Table 3 gives conservative R<sub>COMP</sub> and C<sub>COMP</sub> values for certain inductors, input and output voltages providing a very stable system. For a faster response time, a higher R<sub>COMP</sub> value can be used to enlarge the bandwidth, as well as a slightly lower value of C<sub>COMP</sub> to keep enough phase margin. These adjustments should be performed in parallel with the load transient response monitoring of TPS61087-Q1.

**Input Capacitor Selection**

For good input voltage filtering low ESR ceramic capacitors are recommended. TPS61087-Q1 has an analog input IN. Therefore, a 1 µF bypass is highly recommended as close as possible to the IC from IN to GND.

Two 10 µF (or one 22 µF) ceramic input capacitors are sufficient for most of the applications. For better input voltage filtering this value can be increased. See Table 4 and typical applications for input capacitor recommendation.

**Output Capacitor Selection**

For best output voltage filtering a low ESR output capacitor like ceramic capacitor is recommended. Four 10 µF ceramic output capacitors (or two 22 µF) work for most of the applications. Higher capacitor values can be used to improve the load transient response. See Table 4 for the selection of the output capacitor.

**Table 4. Rectifier Input and Output Capacitor Selection**

	CAPACITOR/SIZE	VOLTAGE RATING	SUPPLIER	COMPONENT CODE
C <sub>IN</sub>	22 µF/1206	16 V	Taiyo Yuden	EMK316 BJ 226ML
IN bypass	1 µF/0603	16 V	Taiyo Yuden	EMK107 BJ 105KA
C <sub>OUT</sub>	10 µF/1206	25 V	Taiyo Yuden	TMK316 BJ 106KL

To calculate the output voltage ripple, the following equation can be used:

$$\Delta V_C = \frac{V_S - V_{IN}}{V_S \cdot f_S} \cdot \frac{I_{out}}{C_{out}} \quad \Delta V_{C\_ESR} = I_{L(peak)} \cdot R_{C\_ESR} \tag{10}$$

with

- ΔV<sub>C</sub> Output voltage ripple dependent on output capacitance, output current and switching frequency
- V<sub>S</sub> Output voltage
- V<sub>IN</sub> Minimum input voltage of boost converter
- f<sub>S</sub> Converter switching frequency (typically 1.2 MHz or 650 kHz)
- I<sub>out</sub> Output capacitance
- ΔV<sub>C\_ESR</sub> Output voltage ripple due to output capacitors ESR (equivalent series resistance)
- I<sub>SWPEAK</sub> Inductor peak switch current in the application
- R<sub>C\_ESR</sub> Output capacitors equivalent series resistance (ESR)

$\Delta V_{C\_ESR}$  can be neglected in many cases since ceramic capacitors provide low ESR.

### Frequency Select Pin (FREQ)

The frequency select pin FREQ allows to set the switching frequency of the device to 650 kHz (FREQ = low) or 1.2 MHz (FREQ = high). Higher switching frequency improves load transient response but reduces slightly the efficiency. The other benefits of higher switching frequency are a lower output ripple voltage. The use of a 1.2 MHz switching frequency is recommended unless light load efficiency is a major concern.

### Undervoltage Lockout (UVLO)

To avoid mis-operation of the device at low input voltages an undervoltage lockout is included that disables the device, if the input voltage falls below 2.4 V.

### Thermal Shutdown

A thermal shutdown is implemented to prevent damages due to excessive heat and power dissipation. Typically the thermal shutdown happens at a junction temperature of 150°C. When the thermal shutdown is triggered the device stops switching until the junction temperature falls below typically 136°C. Then the device starts switching again.

### Overvoltage Prevention

If overvoltage is detected on the FB pin (typically 3 % above the nominal value of 1.238 V) the part stops switching immediately until the voltage on this pin drops to its nominal value. This prevents overvoltage on the output and secures the circuits connected to the output from excessive overvoltage.

APPLICATION INFORMATION

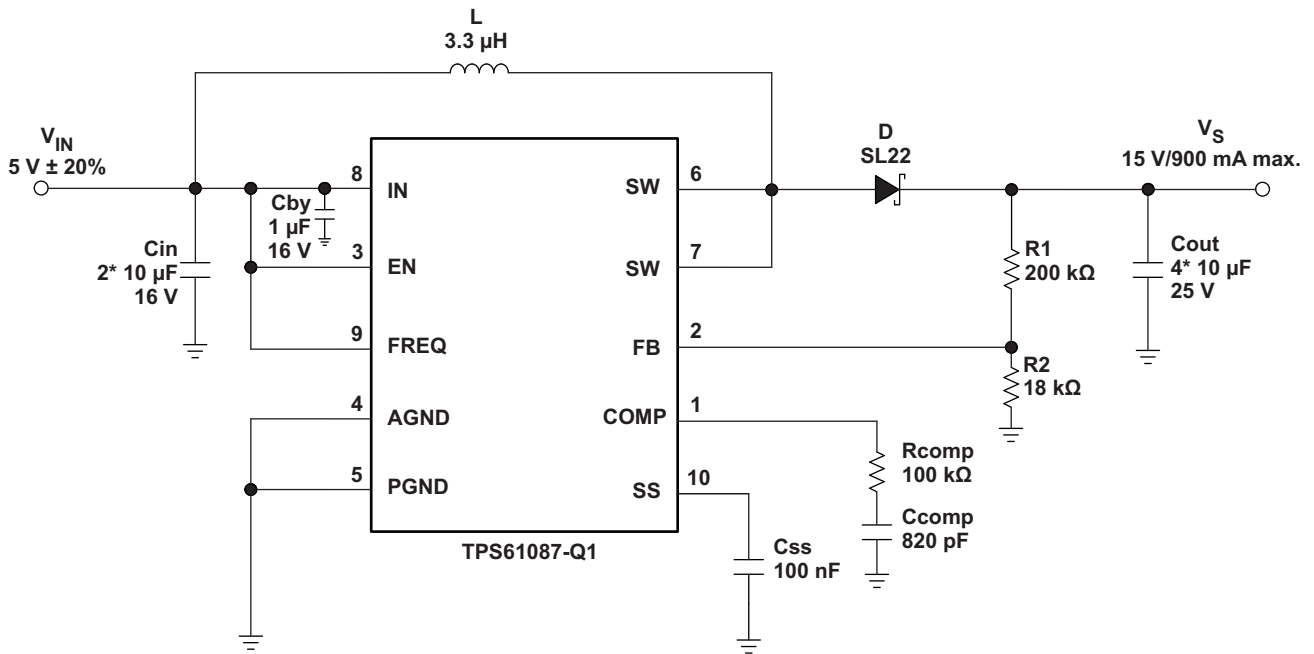

Figure 14. Typical Application, 5 V to 15 V ( $f_s = 1.2\text{ MHz}$ )

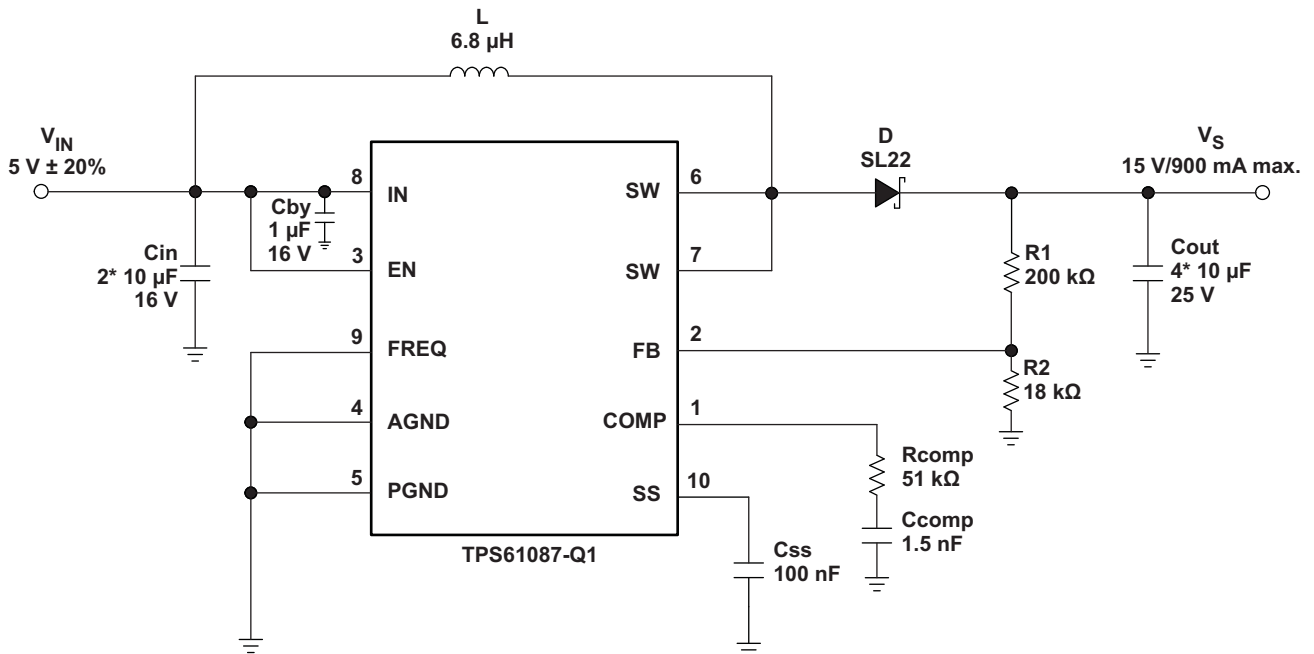

Figure 15. Typical Application, 5 V to 15 V ( $f_s = 650\text{ kHz}$ )

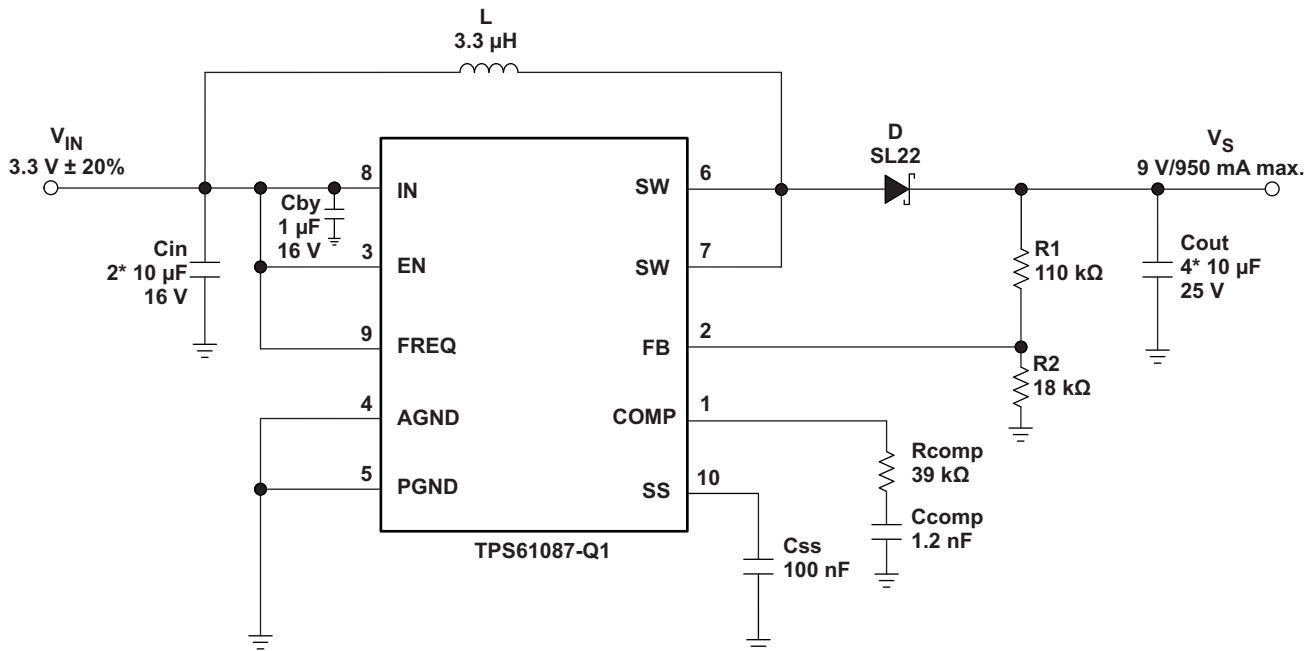

Figure 16. Typical Application, 3.3 V to 9 V ( $f_s = 1.2\text{ MHz}$ )

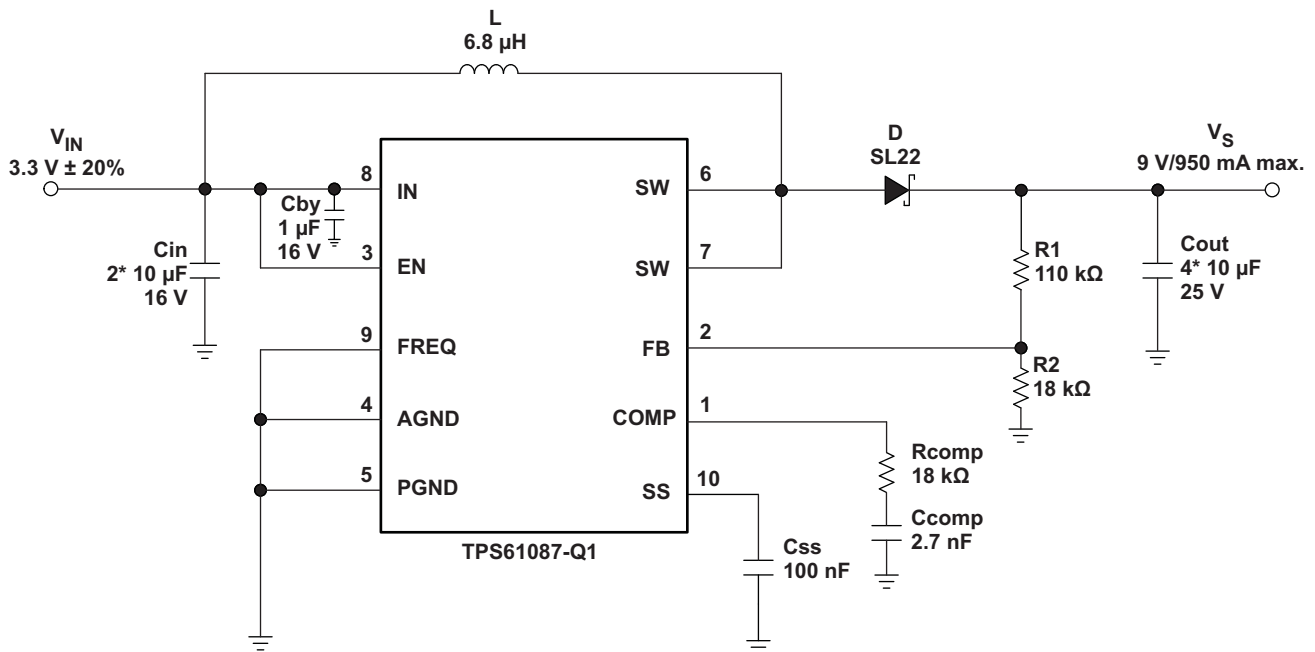

Figure 17. Typical Application, 3.3 V to 9 V ( $f_s = 650\text{ kHz}$ )

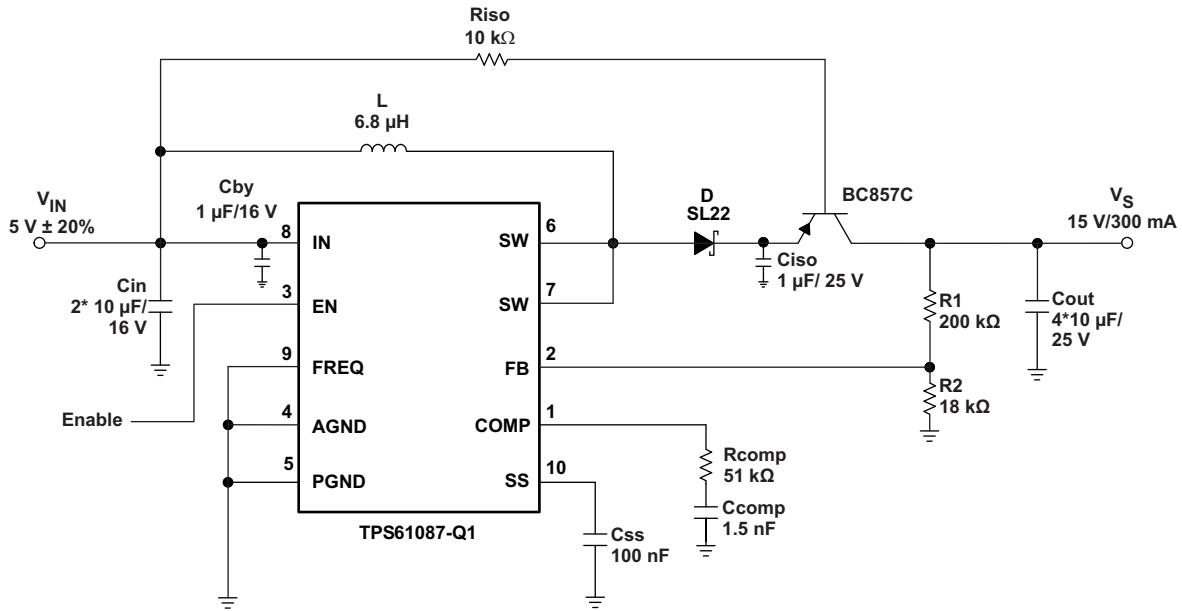

Figure 18. Typical Application with External Load Disconnect Switch

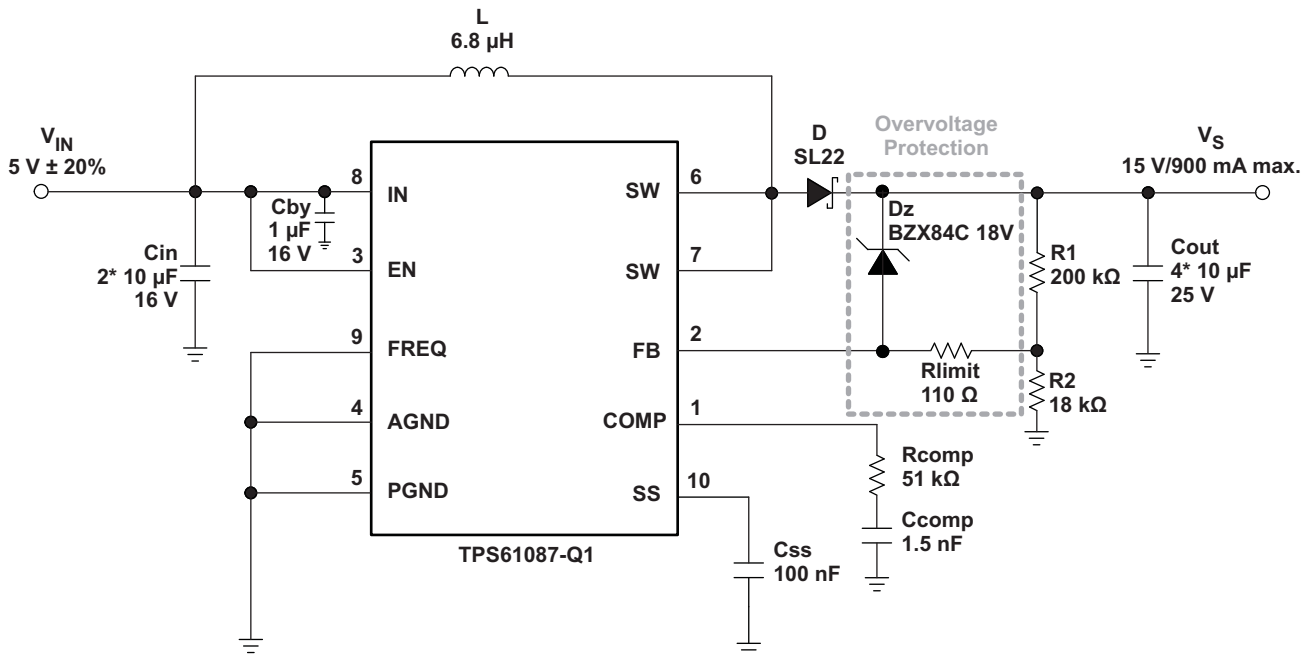

Figure 19. Typical Application, 5 V to 15 V ( $f_s = 1.2$  MHz) with Overvoltage Protection

TFT LCD APPLICATION

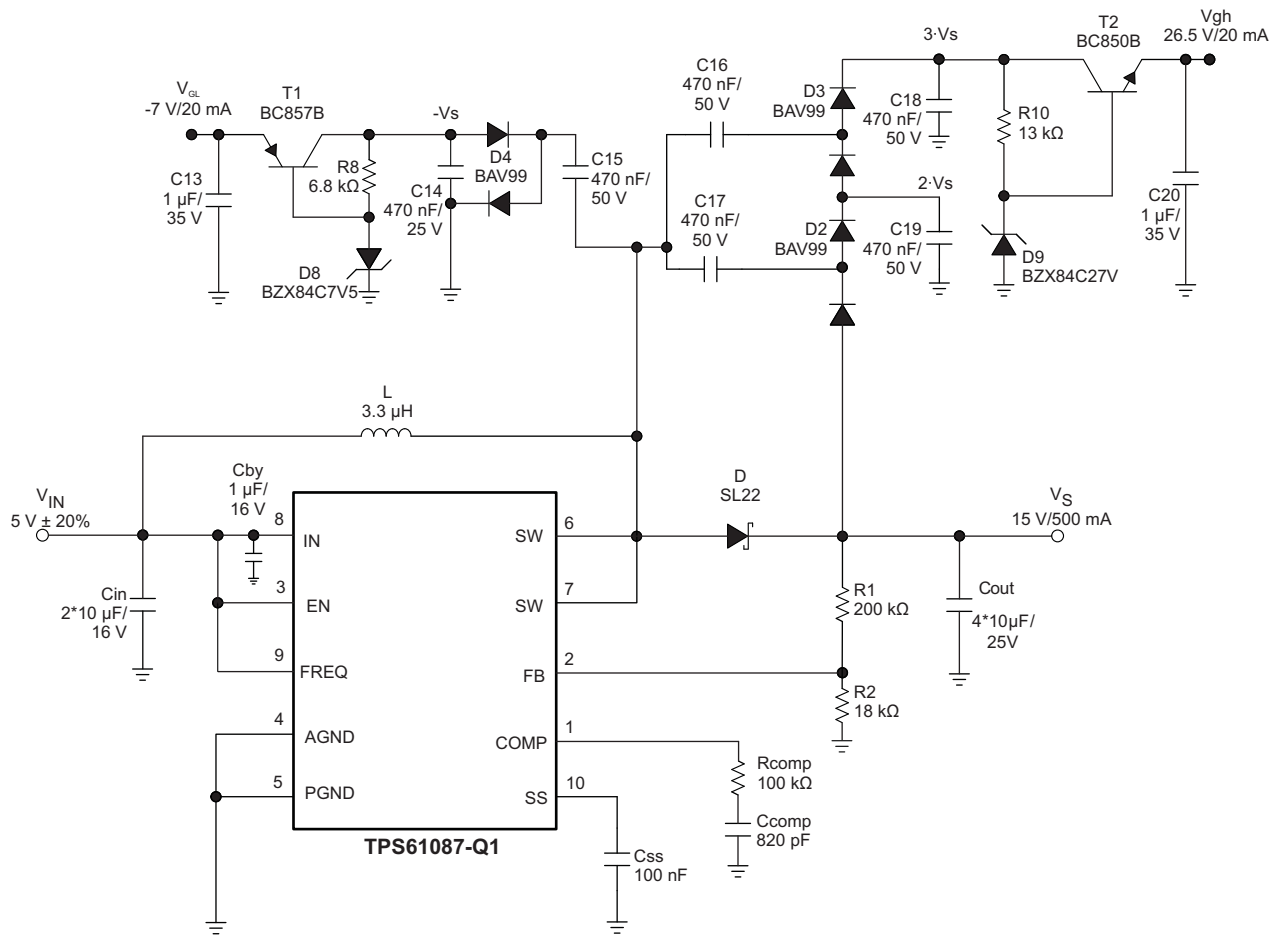

Figure 20. Typical Application 5 V to 15 V ( $f_s = 1.2$  MHz) for TFT LCD with External Charge Pumps (VGH, VGL)

WHITE LED APPLICATIONS

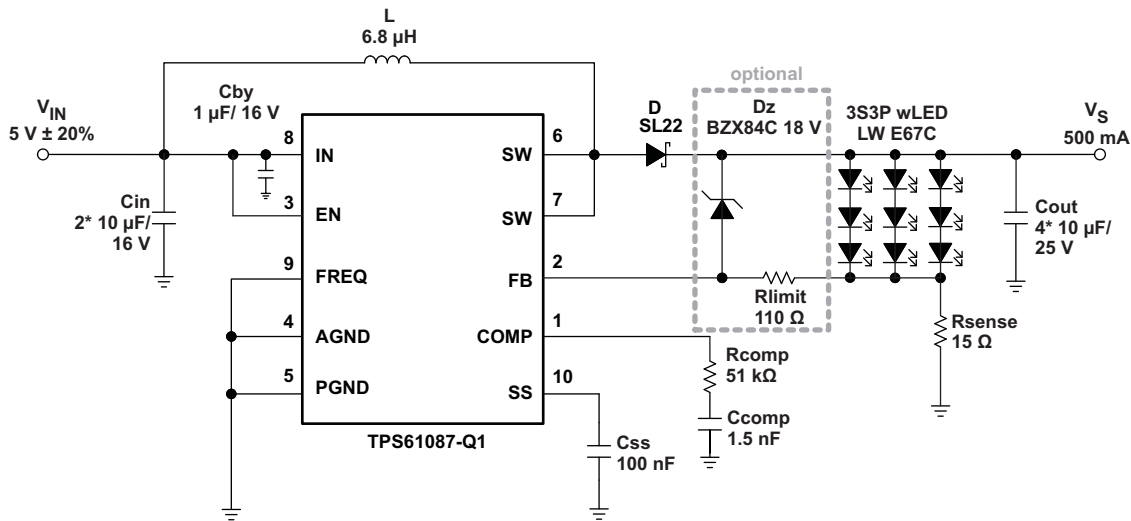

Figure 21. Simple Application (5 V input voltage) ( $f_s = 650$  kHz) for wLED Supply (3S3P) (with optional clamping Zener diode)

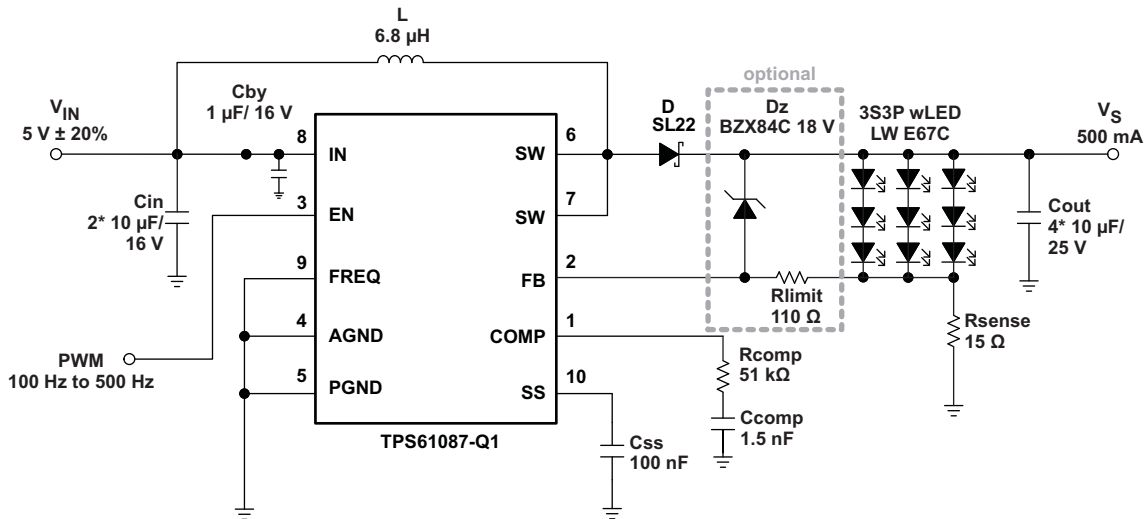

Figure 22. Simple Application (5 V input voltage) ( $f_s = 650$  kHz) for wLED Supply (3S3P) with Adjustable Brightness Control using a PWM Signal on the Enable Pin (with optional clamping Zener diode)

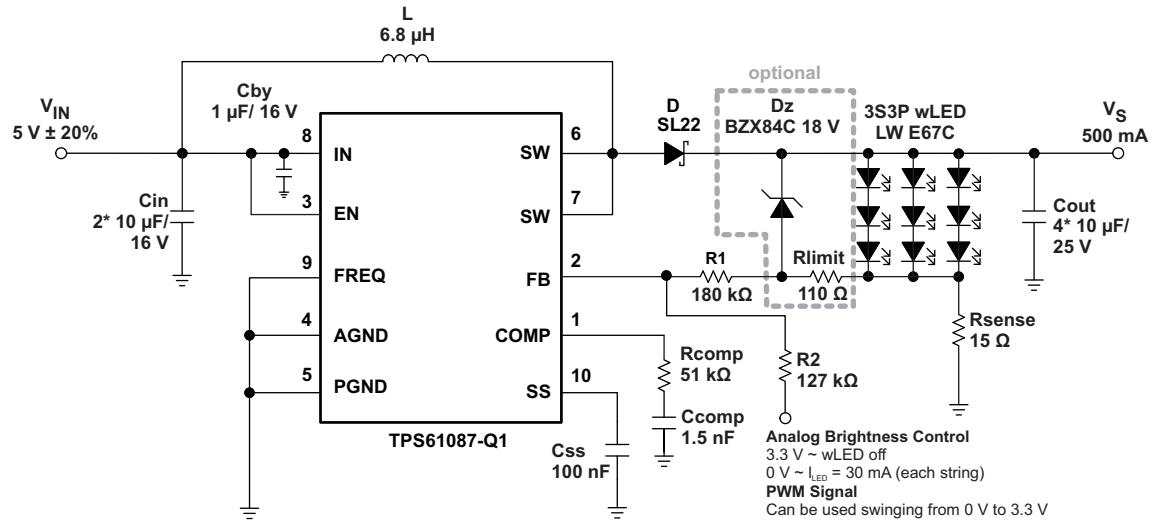

Figure 23. Simple Application (5 V input voltage) ( $f_s = 650$  kHz) for wLED Supply (3S3P) with Adjustable Brightness Control using an Analog Signal on the Feedback Pin (with optional clamping Zener diode)

**PACKAGING INFORMATION**

Orderable Device	Status (1)	Package Type	Package Drawing	Pins	Package Qty	Eco Plan (2)	Lead finish/ Ball material (6)	MSL Peak Temp (3)	Op Temp (°C)	Device Marking (4/5)	Samples
TPS61087QDRCRQ1	ACTIVE	VSON	DRC	10	3000	RoHS & Green	NIPDAU	Level-3-260C-168 HR	-40 to 125	PMOQ	<b>Samples</b>
TPS61087QWDRCRQ1	ACTIVE	VSON	DRC	10	3000	RoHS & Green	SN	Level-3-260C-168 HR	-40 to 125	11ZC	<b>Samples</b>

(1) The marketing status values are defined as follows:

**ACTIVE:** Product device recommended for new designs.

**LIFEBUY:** TI has announced that the device will be discontinued, and a lifetime-buy period is in effect.

**NRND:** Not recommended for new designs. Device is in production to support existing customers, but TI does not recommend using this part in a new design.

**PREVIEW:** Device has been announced but is not in production. Samples may or may not be available.

**OBSOLETE:** TI has discontinued the production of the device.

(2) **RoHS:** TI defines "RoHS" to mean semiconductor products that are compliant with the current EU RoHS requirements for all 10 RoHS substances, including the requirement that RoHS substance do not exceed 0.1% by weight in homogeneous materials. Where designed to be soldered at high temperatures, "RoHS" products are suitable for use in specified lead-free processes. TI may reference these types of products as "Pb-Free".

**RoHS Exempt:** TI defines "RoHS Exempt" to mean products that contain lead but are compliant with EU RoHS pursuant to a specific EU RoHS exemption.

**Green:** TI defines "Green" to mean the content of Chlorine (Cl) and Bromine (Br) based flame retardants meet JS709B low halogen requirements of <=1000ppm threshold. Antimony trioxide based flame retardants must also meet the <=1000ppm threshold requirement.

(3) MSL, Peak Temp. - The Moisture Sensitivity Level rating according to the JEDEC industry standard classifications, and peak solder temperature.

(4) There may be additional marking, which relates to the logo, the lot trace code information, or the environmental category on the device.

(5) Multiple Device Markings will be inside parentheses. Only one Device Marking contained in parentheses and separated by a "~" will appear on a device. If a line is indented then it is a continuation of the previous line and the two combined represent the entire Device Marking for that device.

(6) Lead finish/Ball material - Orderable Devices may have multiple material finish options. Finish options are separated by a vertical ruled line. Lead finish/Ball material values may wrap to two lines if the finish value exceeds the maximum column width.

**Important Information and Disclaimer:**The information provided on this page represents TI's knowledge and belief as of the date that it is provided. TI bases its knowledge and belief on information provided by third parties, and makes no representation or warranty as to the accuracy of such information. Efforts are underway to better integrate information from third parties. TI has taken and continues to take reasonable steps to provide representative and accurate information but may not have conducted destructive testing or chemical analysis on incoming materials and chemicals. TI and TI suppliers consider certain information to be proprietary, and thus CAS numbers and other limited information may not be available for release.

In no event shall TI's liability arising out of such information exceed the total purchase price of the TI part(s) at issue in this document sold by TI to Customer on an annual basis.



## GENERIC PACKAGE VIEW

**DRC 10**

**VSON - 1 mm max height**

3 x 3, 0.5 mm pitch

PLASTIC SMALL OUTLINE - NO LEAD

This image is a representation of the package family, actual package may vary.  
Refer to the product data sheet for package details.

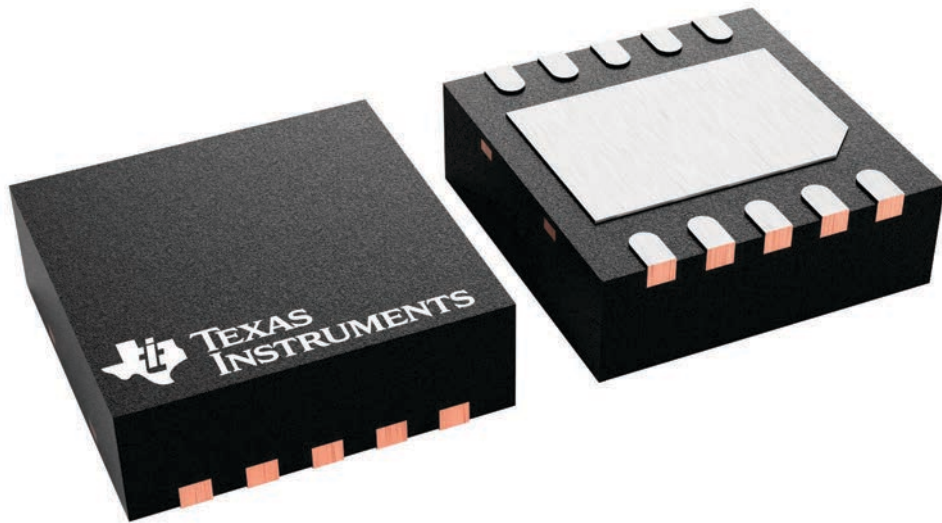

4226193/A



# EXAMPLE BOARD LAYOUT

DRC0010R

VSON - 1 mm max height

PLASTIC SMALL OUTLINE - NO LEAD

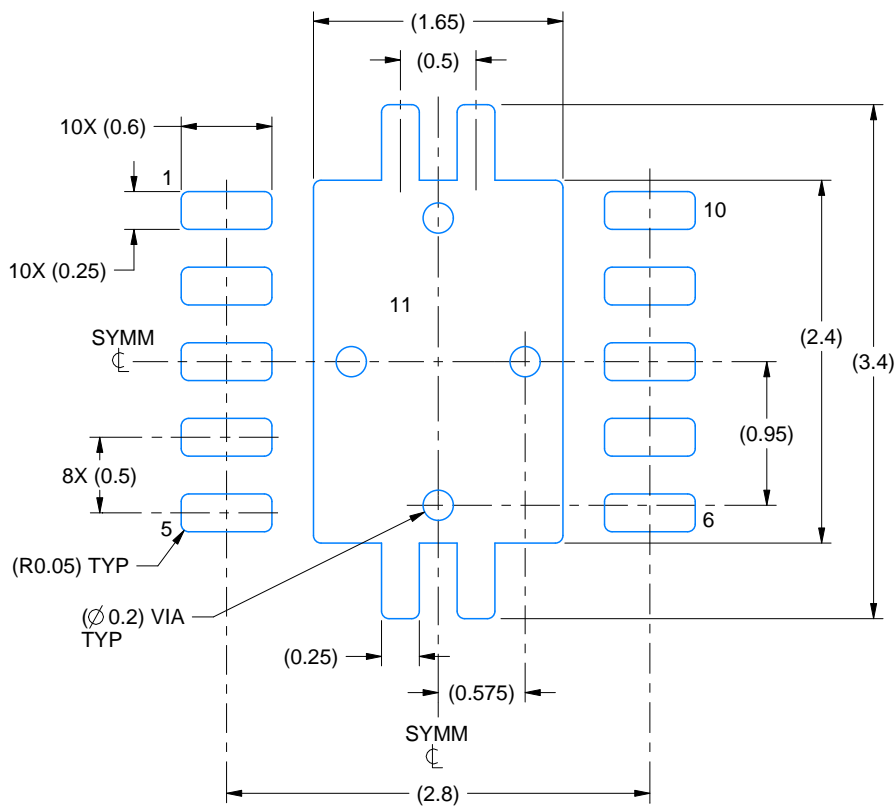

LAND PATTERN EXAMPLE  
EXPOSED METAL SHOWN  
SCALE:20X

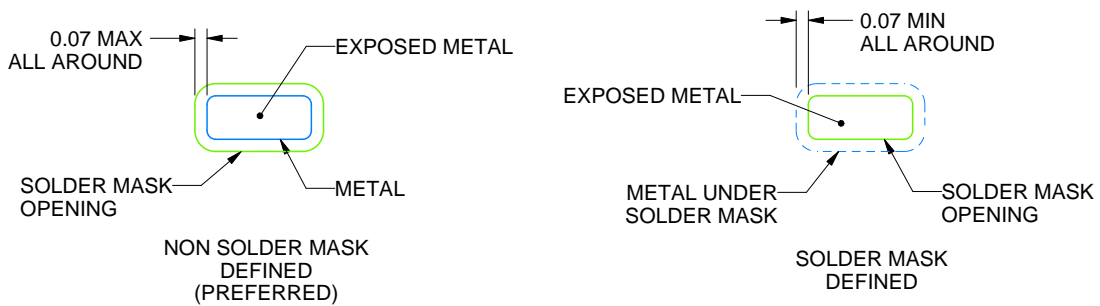

SOLDER MASK DETAILS

4223412/A 01/2017

NOTES: (continued)

4. This package is designed to be soldered to a thermal pad on the board. For more information, see Texas Instruments literature number SLUA271 ([www.ti.com/lit/sluea271](http://www.ti.com/lit/sluea271)).
5. Vias are optional depending on application, refer to device data sheet. If any vias are implemented, refer to their locations shown on this view. It is recommended that vias under paste be filled, plugged or tented.

# EXAMPLE STENCIL DESIGN

DRC0010R

VSON - 1 mm max height

PLASTIC SMALL OUTLINE - NO LEAD

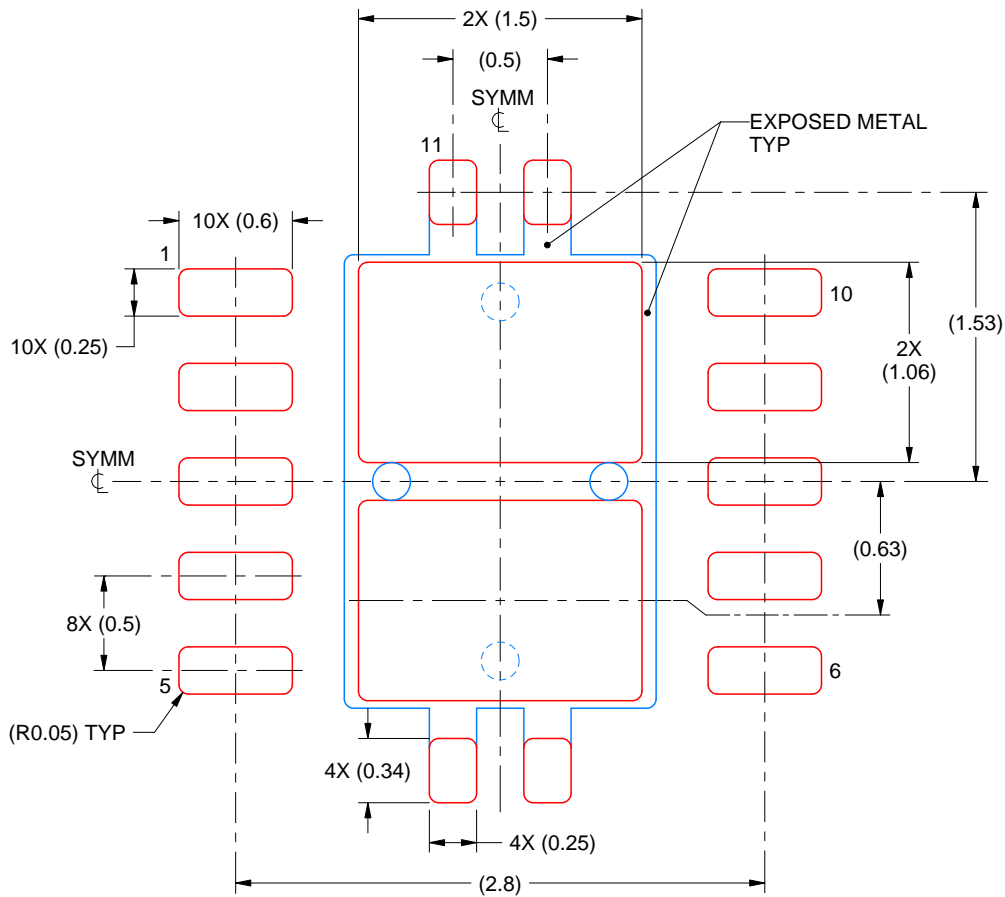

SOLDER PASTE EXAMPLE  
BASED ON 0.125 mm THICK STENCIL

EXPOSED PAD 11:  
80% PRINTED SOLDER COVERAGE BY AREA  
SCALE:25X

4223412/A 01/2017

NOTES: (continued)

6. Laser cutting apertures with trapezoidal walls and rounded corners may offer better paste release. IPC-7525 may have alternate design recommendations.



# EXAMPLE BOARD LAYOUT

DRC0010J

VSON - 1 mm max height

PLASTIC SMALL OUTLINE - NO LEAD

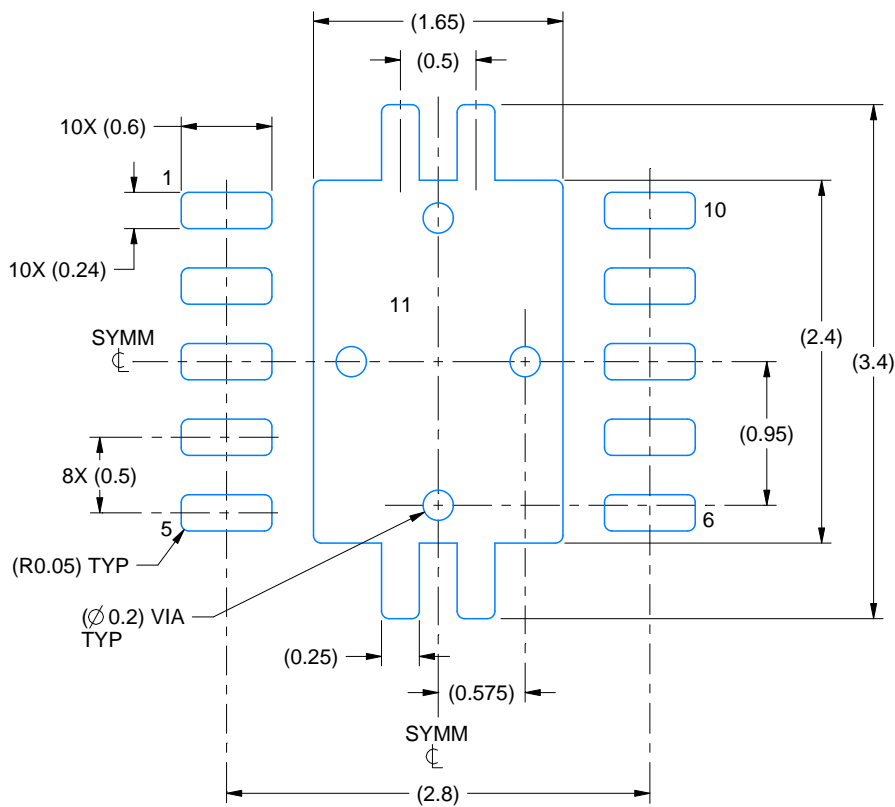

LAND PATTERN EXAMPLE  
EXPOSED METAL SHOWN  
SCALE:20X

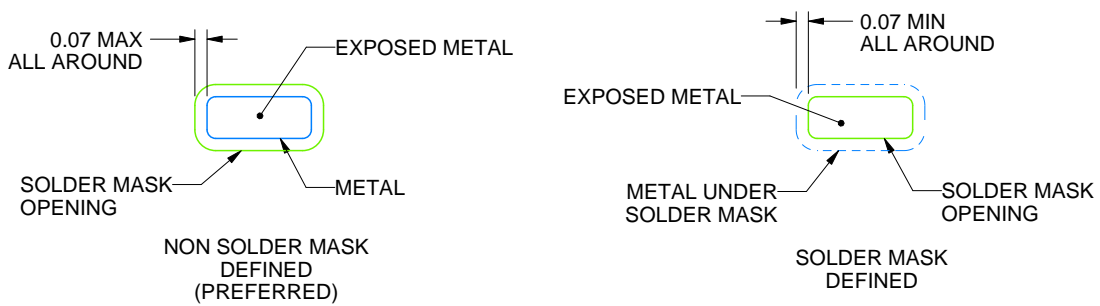

SOLDER MASK DETAILS

4218878/B 07/2018

NOTES: (continued)

4. This package is designed to be soldered to a thermal pad on the board. For more information, see Texas Instruments literature number SLUA271 ([www.ti.com/lit/sluea271](http://www.ti.com/lit/sluea271)).
5. Vias are optional depending on application, refer to device data sheet. If any vias are implemented, refer to their locations shown on this view. It is recommended that vias under paste be filled, plugged or tented.

# EXAMPLE STENCIL DESIGN

DRC0010J

VSON - 1 mm max height

PLASTIC SMALL OUTLINE - NO LEAD

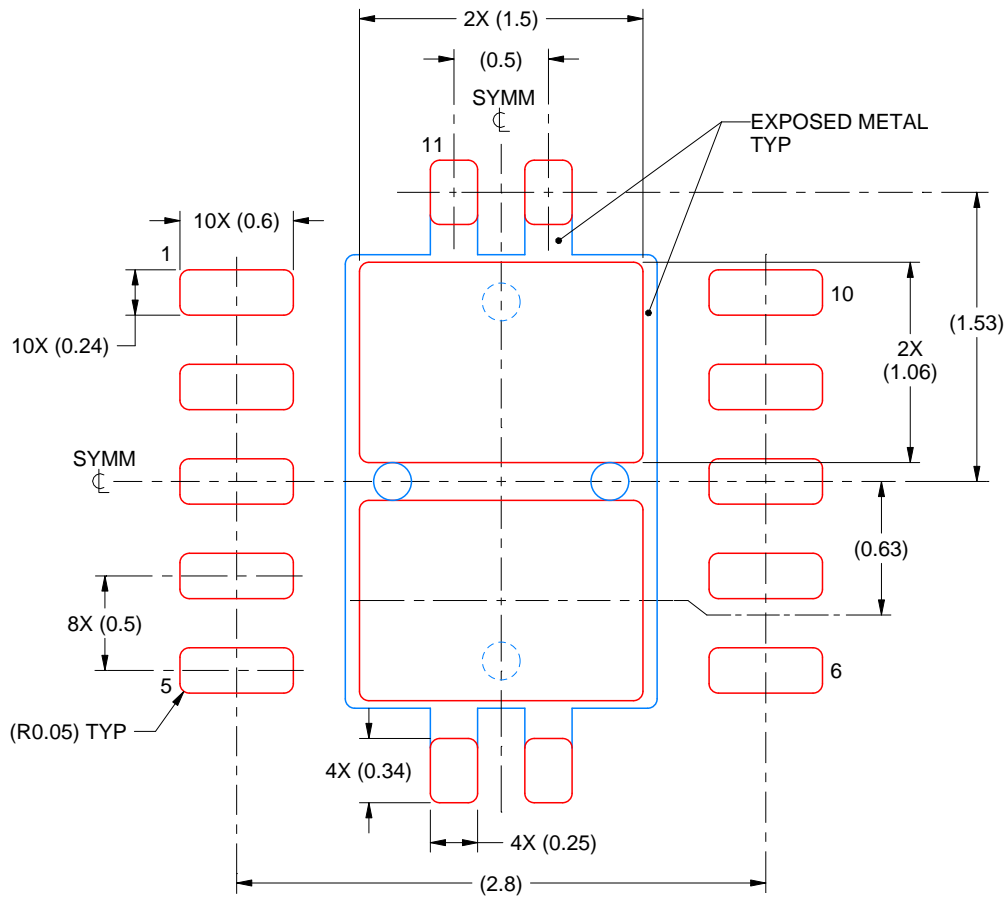

SOLDER PASTE EXAMPLE  
BASED ON 0.125 mm THICK STENCIL

EXPOSED PAD 11:  
80% PRINTED SOLDER COVERAGE BY AREA  
SCALE:25X

4218878/B 07/2018

NOTES: (continued)

6. Laser cutting apertures with trapezoidal walls and rounded corners may offer better paste release. IPC-7525 may have alternate design recommendations.

## 重要声明和免责声明

TI 均以“原样”提供技术性及其可靠性数据（包括数据表）、设计资源（包括参考设计）、应用或其他设计建议、网络工具、安全信息和其他资源，不保证其中不含任何瑕疵，且不做任何明示或暗示的担保，包括但不限于对适销性、适合某特定用途或不侵犯任何第三方知识产权的暗示担保。

所述资源可供专业开发人员应用TI 产品进行设计使用。您将对以下行为独自承担全部责任：(1) 针对您的应用选择合适的TI 产品；(2) 设计、验证并测试您的应用；(3) 确保您的应用满足相应标准以及任何其他安全、安保或其他要求。所述资源如有变更，恕不另行通知。TI 对您使用所述资源的授权仅限于开发资源所涉及TI 产品的相关应用。除此之外不得复制或展示所述资源，也不提供其它TI 或任何第三方的知识产权授权许可。如因使用所述资源而产生任何索赔、赔偿、成本、损失及债务等，TI 对此概不负责，并且您须赔偿由此对TI 及其代表造成的损害。

TI 所提供产品均受TI 的销售条款 (<http://www.ti.com.cn/zh-cn/legal/termsofsale.html>) 以及ti.com.cn上或随附TI产品提供的其他可适用条款的约束。TI提供所述资源并不扩展或以其他方式更改TI 针对TI 产品所发布的可适用的担保范围或担保免责声明。

邮寄地址：上海市浦东新区世纪大道 1568 号中建大厦 32 楼，邮政编码：200122

Copyright © 2020 德州仪器半导体技术（上海）有限公司