

16-Channel, 12-Bit PWM LED Driver with 6-Bit Dot Correction

FEATURES

- 16 Channels, Constant-Current Sink Output
- 40-mA Capability (Constant-Current Sink)
- 12-Bit (4096 Steps) Grayscale PWM Control
- 6-Bit (64 Steps) Dot Correction
- LED Power-Supply Voltage up to 17 V
- $V_{CC} = 3.0\text{ V to }5.5\text{ V}$
- **Constant-Current Accuracy:**
 - Channel-to-Channel = $\pm 1\%$ (typ)
 - Device-to-Device = $\pm 2\%$ (typ)
- 30-MHz Data Transfer Rate
- 33-MHz Grayscale PWM Clock
- Extended Serial Interface
- CMOS Level I/O
- Schmitt Buffer Input
- **Readable Error Information:**
 - Continuous Base LED Open Detection (LOD)
 - Thermal Error Flag (TEF)
- **Noise Reduction:**
 - 4-Channel Grouped Delay
- **Operating Temperature: $-40^{\circ}\text{C to }+85^{\circ}\text{C}$**

APPLICATIONS

- Monochrome, Multicolor, Full-Color LED Displays
- LED Signboards
- Display Backlighting

DESCRIPTION

The TLC59461 is a 16-channel, constant-current sink LED driver. Each channel is individually adjustable with 4096 pulse-width modulated (PWM) steps and 64 constant-current sink steps for dot correction. The dot correction adjusts the brightness variations between LEDs. Both grayscale control and dot correction are accessible via serial interface. The maximum current value of all 16 channels can be set by a single external resistor.

The TLC59461 has two error information circuits: one for LED open detection (LOD), and a thermal error flag (TEF). LOD detects a broken or disconnected LED during display period. TEF indicates an over-temperature condition.

To allow lower power dissipation, the TLC59461 does not implement the Auto Output Off function available in the [TLC5946](#).

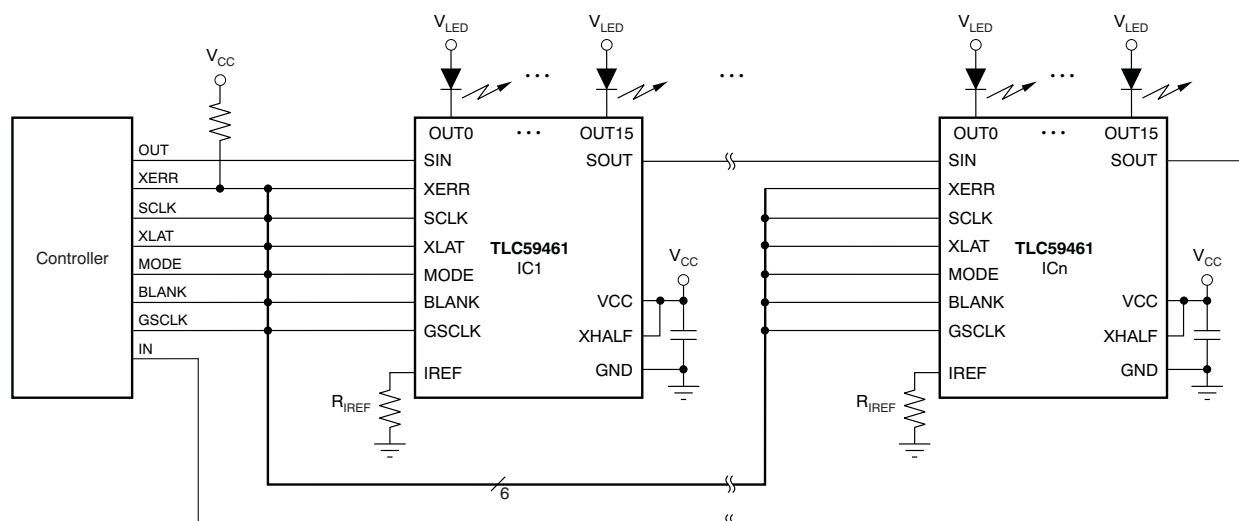

Typical Application Circuit (Multiple Daisy-Chained TLC59461s)



Please be aware that an important notice concerning availability, standard warranty, and use in critical applications of Texas Instruments semiconductor products and disclaimers thereto appears at the end of this data sheet.

PowerPAD is a trademark of Texas Instruments, Inc.
All other trademarks are the property of their respective owners.



This integrated circuit can be damaged by ESD. Texas Instruments recommends that all integrated circuits be handled with appropriate precautions. Failure to observe proper handling and installation procedures can cause damage.

ESD damage can range from subtle performance degradation to complete device failure. Precision integrated circuits may be more susceptible to damage because very small parametric changes could cause the device not to meet its published specifications.

PACKAGE/ORDERING INFORMATION⁽¹⁾

PRODUCT	PACKAGE-LEAD	ORDERING NUMBER	TRANSPORT MEDIA, QUANTITY
TLC59461	HTSSOP-28 PowerPAD™	TLC59461PWPR	Tape and Reel, 2000
		TLC59461PWP	Tube, 50

(1) For the most current package and ordering information see the Package Option Addendum at the end of this document, or see the TI web site at www.ti.com.

ABSOLUTE MAXIMUM RATINGS⁽¹⁾⁽²⁾

Over operating free-air temperature range, unless otherwise noted.

PARAMETER		TLC59461	UNIT
V_{CC}	Supply voltage: V_{CC}	-0.3 to +6.0	V
I_{OUT}	Output current (dc)	OUT0 to OUT15	50
		XERR	6
V_{IN}	Input voltage range: SIN, SCLK, GSCLK, XLAT, BLANK, MODE, XHALF, IREF	-0.3 to $V_{CC} + 0.3$	V
V_{OUT}	Output voltage range	SOUT, XERR	-0.3 to $V_{CC} + 0.3$
		OUT0 to OUT15	-0.3 to +18
$T_{J(ABS)}$	Operating temperature range: junction temperature	-40 to +150	°C
T_{STG}	Storage temperature range	-55 to +150	°C
ESD rating	Human body model (HBM), JEDEC JESD22-A114	2	kV
	Charged device model (CDM), JEDEC JESD22-C101	500	V

- (1) Stresses above these ratings may cause permanent damage. Exposure to absolute maximum conditions for extended periods may degrade device reliability. These are stress ratings only, and functional operation of the device at these or any other conditions beyond those specified is not supported.
- (2) All voltage values are with respect to network ground terminal.

DISSIPATION RATINGS

PACKAGE	OPERATING FACTOR ABOVE $T_A = +25^\circ\text{C}$	$T_A < +25^\circ\text{C}$ POWER RATING	$T_A = +70^\circ\text{C}$ POWER RATING	$T_A = +85^\circ\text{C}$ POWER RATING
HTSSOP-28 with PowerPAD soldered ⁽¹⁾	31.67 mW/°C	3958 mW	2533 mW	2058 mW
HTSSOP-28 with PowerPAD not soldered ⁽²⁾	16.21 mW/°C	2026 mW	1296 mW	1053 mW

- (1) With PowerPAD soldered onto copper area on printed circuit board (PCB); 2 oz. copper. For more information, see [SLMA002](#) (available for download at www.ti.com).
- (2) With PowerPAD not soldered onto copper area on PCB.

RECOMMENDED OPERATING CONDITIONS

 At $T_A = -40^{\circ}\text{C}$ to $+85^{\circ}\text{C}$, unless otherwise noted.

PARAMETER		TEST CONDITIONS	TLC59461			UNIT
			MIN	NOM	MAX	
DC Characteristics: $V_{CC} = 3\text{ V}$ to 5.5 V						
V_{CC}	Supply voltage		3.0		5.5	V
V_O	Voltage applied to output	OUT0 to OUT15			17	V
V_{IH}	High-level input voltage		$0.7 \times V_{CC}$		V_{CC}	V
V_{IL}	Low-level input voltage		GND		$0.3 \times V_{CC}$	V
I_{OH}	High-level output current	SOUT			-1	mA
I_{OL}	Low-level output current	SOUT			1	mA
		XERR			5	mA
I_{OLC}	Constant output sink current	OUT0 to OUT15, DC = 3Fh	4		40	mA
T_A	Operating free-air temperature range		-40		+85	$^{\circ}\text{C}$
T_J	Operating junction temperature		-40		+125	$^{\circ}\text{C}$
AC Characteristics: $V_{CC} = 3\text{ V}$ to 5.5 V						
$f_{CLK}(\text{sclk})$	Data shift clock frequency	SCLK, XHALF = H			30	MHz
		GSCLK, XHALF = L			15	MHz
$f_{CLK}(\text{gsclk})$	Grayscale control clock frequency	GSCLK			33	MHz
T_{WH0} / T_{WL0}	SCLK pulse duration	SCLK = H/L (see Figure 12)	10			ns
T_{WH1} / T_{WL1}	GSCLK pulse duration	GSCLK = H/L (see Figure 12)	10			ns
T_{WH2}	XLAT pulse duration	XLAT = H (see Figure 12)	20			ns
T_{WH3}	BLANK pulse duration	BLANK = H (see Figure 12)	20			ns
T_{SU0}	Setup time	SIN–SCLK \uparrow (see Figure 12)	5			ns
T_{SU1}		XLAT \uparrow –SCLK \uparrow (see Figure 37 , Figure 12)	100			ns
T_{SU2}		MODE–SCLK \uparrow (see Figure 12)	10			ns
T_{SU3}		MODE–XLAT \uparrow (see Figure 12)	10			ns
T_{SU4}		BLANK \downarrow –GSCLK \uparrow (see Figure 12)	10			ns
T_{SU5}		XLAT \uparrow –GSCLK \uparrow (see Figure 12)	30			ns
T_{SU6}		SCLK \downarrow –XLAT \uparrow (see Figure 12 , Figure 37)	10			ns
T_{H0}	Hold time	SIN–SCLK \uparrow (see Figure 12)	3			ns
T_{H1}		MODE–SCLK \downarrow (see Figure 12)	10			ns
T_{H2}		MODE–XLAT \uparrow (see Figure 12)	100			ns
AC Characteristics: $V_{CC} = 3\text{ V}$ to 5.5 V, XHALF = L						
T_{WL2}	XLAT pulse duration	XLAT = L (see Figure 37)	20			ns
T_{SU7}	Setup time	BLANK \uparrow –XLAT \uparrow (see Figure 37)	20			ns
T_{H3}	Hold time	BLANK \downarrow –XLAT \downarrow (see Figure 37)	20			ns

ELECTRICAL CHARACTERISTICS

At $V_{CC} = 3.0\text{ V}$ to 5.5 V , $T_A = -40^\circ\text{C}$ to $+85^\circ\text{C}$, and $R_{IREF} = 1.3\text{ k}\Omega$. Typical values at $V_{CC} = 3.3\text{ V}$ and $T_A = +25^\circ\text{C}$, unless otherwise noted.

PARAMETER		TEST CONDITIONS	TLC59461			UNIT	
			MIN	TYP	MAX		
V_{OH}	High-level output voltage	$I_{OH} = -1\text{ mA}$ at SOUT	$V_{CC} - 0.4$			V	
V_{OL}	Low-level output voltage	$I_{OL} = 1\text{ mA}$ at SOUT	0.4			V	
		$I_{OL} = 5\text{ mA}$ at XERR	0.5			V	
I_{IN}	Input current	$V_{IN} = V_{CC}$ or GND at BLANK, XHALF, GSCLK, SCLK, SIN, XLAT, and MODE pins	-1			μA	
I_{CC1}	Supply current	No data transfer, all $OUT_n = \text{OFF}$, $V_{OUTn} = 1\text{ V}$, $DCn = 3Fh$, $R_{IREF} = 13\text{ k}\Omega$	0.9			3	mA
I_{CC2}		No data transfer, all $OUT_n = \text{OFF}$, $V_{OUTn} = 1\text{ V}$, $DCn = 3Fh$, $R_{IREF} = 2.7\text{ k}\Omega$	4			8	mA
I_{CC3}		Data transfer at 30 MHz, all $OUT_n = \text{ON}$, $V_{OUTn} = 1\text{ V}$, $DCn = 3Fh$, $R_{IREF} = 2.7\text{ k}\Omega$	13			25	mA
I_{CC4}		Data transfer at 30 MHz, all $OUT_n = \text{ON}$, $V_{OUTn} = 1\text{ V}$, $DCn = 3Fh$	20			45	mA
I_{OLC}	Constant output current	All $OUT_n = \text{ON}$, $V_{OUTn} = 1\text{ V}$, $V_{OUTfix} = 1\text{ V}$, $DCn = 3Fh$	35.5	39.0	42.5	mA	
I_{OLK1}	Output leakage current	All $OUT_n = \text{OFF}$, $V_{OUTn} = 17\text{ V}$, $DCn = 3Fh$ At OUT_0 to OUT_{15}	0.1			μA	
I_{OLK2}	Output leakage current	No error condition, $V_{XERR} = 5.5\text{ V}$, at XERR	1			μA	
ΔI_{OLC}	Constant-current error (channel-to-channel) ⁽¹⁾	All $OUT_n = \text{ON}$, $V_{OUTn} = 1\text{ V}$, $V_{OUTfix} = 1\text{ V}$, $DCn = 3Fh$	± 1			± 3	%
ΔI_{OLC1}	Constant-current error (device-to-device) ⁽²⁾	All $OUT_n = \text{ON}$, $V_{OUTn} = 1\text{ V}$, $V_{OUTfix} = 1\text{ V}$, $DCn = 3Fh$	± 2			± 6	%
ΔI_{OLC2}	Line regulation ⁽³⁾	All $OUT_n = \text{ON}$, $V_{OUTn} = 1\text{ V}$, $V_{OUTfix} = 1\text{ V}$, $V_{CC} = 3.0\text{ V}$ to 5.5 V , $DCn = 3Fh$	± 0.5			± 1	%
ΔI_{OLC3}	Load regulation ⁽⁴⁾	All $OUT_n = \text{ON}$, $V_{OUTn} = 1\text{ V}$ to 3 V , $V_{OUTfix} = 1\text{ V}$, $DCn = 3Fh$	± 1			± 3	%/V
T_{TEF}	Thermal error flag threshold	Junction temperature ⁽⁵⁾	+150	+162	+175	$^\circ\text{C}$	
T_{HYS}	Thermal error hysteresis	Junction temperature ⁽⁵⁾	+5	+10	+20	$^\circ\text{C}$	
V_{LOD}	LED open detection threshold	All $OUT_n = \text{ON}$	0.2	0.3	0.4	V	
V_{IREF}	Reference voltage output		1.16	1.20	1.24	V	

(1) The deviation of each output from the average of OUT_0 - OUT_{15} constant current. Deviation is calculated by the formula:

$$\Delta (\%) = \left[\frac{I_{OUTn}}{\frac{(I_{OUT0} + I_{OUT1} + \dots + I_{OUT15})}{16}} - 1 \right] \times 100$$

(2) The deviation of the OUT_0 - OUT_{15} constant-current average from the ideal constant-current value. Deviation is calculated by the following formula:

$$\Delta (\%) = \left[\frac{\frac{(I_{OUT0} + I_{OUT1} + \dots + I_{OUT14} + I_{OUT15})}{16} - (\text{Ideal Output Current})}{\text{Ideal Output Current}} \right] \times 100$$

Ideal current is calculated by the formula:

$$I_{OUT(\text{IDEAL})} = 42.5 \times \left[\frac{1.20}{R_{IREF}} \right]$$

(3) Line regulation is calculated by this equation:

$$\Delta (\%/V) = \left[\frac{(I_{OUTn} \text{ at } V_{CC} = 5.5\text{ V}) - (I_{OUTn} \text{ at } V_{CC} = 3.0\text{ V})}{(I_{OUTn} \text{ at } V_{CC} = 3.0\text{ V})} \right] \times \frac{100}{5.5\text{ V} - 3\text{ V}}$$

(4) Load regulation is calculated by the equation:

$$\Delta (\%/V) = \left[\frac{(I_{OUTn} \text{ at } V_{OUTn} = 3\text{ V}) - (I_{OUTn} \text{ at } V_{OUTn} = 1\text{ V})}{(I_{OUTn} \text{ at } V_{OUTn} = 1\text{ V})} \right] \times \frac{100}{3\text{ V} - 1\text{ V}}$$

(5) Not tested. Specified by design.

SWITCHING CHARACTERISTICS

At $V_{CC} = 3.0\text{ V to }5.5\text{ V}$, $T_A = -40^\circ\text{C to }+85^\circ\text{C}$, $C_{L0} = 15\text{ pF}$, $R_{L0} = 100\ \Omega$, $C_{L1} = 100\text{ pF}$, $R_{L1} = 1\text{ k}\Omega$, $R_{IREF} = 1.3\text{ k}\Omega$, $V_{LED} = 5\text{ V}$, and $V_{XERR} = 5\text{ V}$. Typical values at $V_{CC} = 3.3\text{ V}$ and $T_A = +25^\circ\text{C}$, unless otherwise noted.

PARAMETER		TEST CONDITIONS	TLC59461			UNIT
			MIN	TYP	MAX	
t_{R0}	Rise time	SOUT (see Figure 11)			16	ns
t_{R1}		OUTn, $V_{CC} = 5\text{ V}$, DC = 3Fh (see Figure 11)		10	30	
t_{F0}	Fall time	SOUT (see Figure 11)			16	ns
t_{F1}		OUTn, $V_{CC} = 5\text{ V}$, DC = 3Fh (see Figure 11)		10	30	
t_{F2}		XERR (see Figure 11)			100	
t_{D0}	Propagation delay time	SCLK to SOUT (see Figure 12) ⁽¹⁾			25	ns
t_{D1}		BLANK \uparrow to OUT0 sink current off (see Figure 12)		20	40	ns
t_{D2}		GSCLK \uparrow to OUT0/4/8/12 (see Figure 12)	5	18	40	ns
t_{D3}		GSCLK \uparrow to OUT1/5/9/13 (see Figure 12)	20	42	73	ns
t_{D4}		GSCLK \uparrow to OUT2/6/10/14 (see Figure 12)	35	66	106	ns
t_{D5}		GSCLK \uparrow to OUT3/7/11/15 (see Figure 12)	50	90	140	ns
t_{D6}		XLAT \uparrow to OUTn (dot correction) 00h to 3Fh, 3Fh to 00h (see Figure 12)			100	ns
t_{ON_ERR}	Output on-time error	$t_{OUTON} - t_{GSCLK}$, GS $n = 001h$, GSCLK = 33 MHz (see Figure 13)	-20		10	ns

(1) XHALF = H: rising edge of SCLK to SOUT; XHALF = L: falling edge of SCLK to SOUT.

FUNCTIONAL BLOCK DIAGRAM

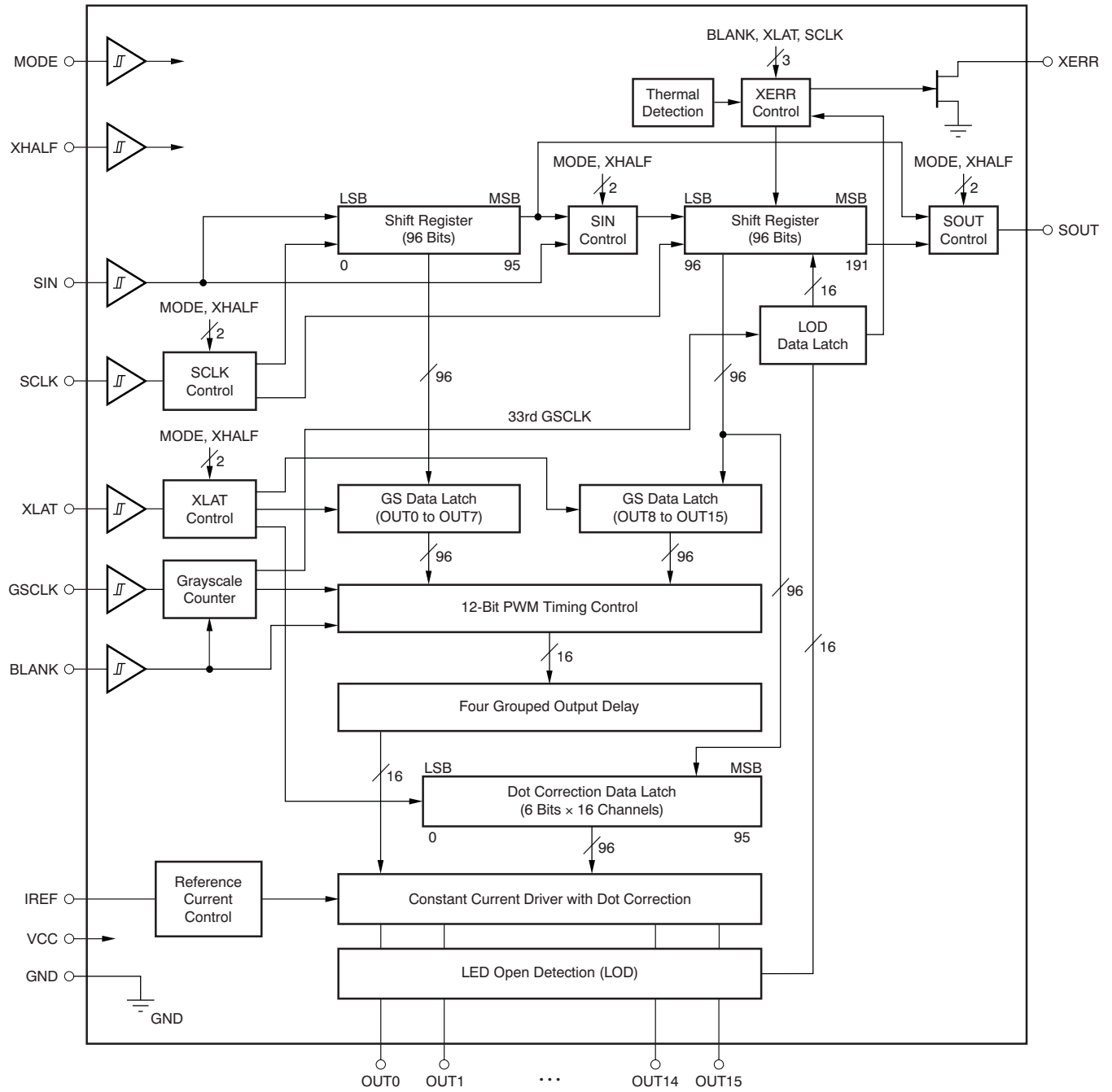

DEVICE INFORMATION

**HTSSOP-28
PWP PACKAGE
(TOP VIEW)**

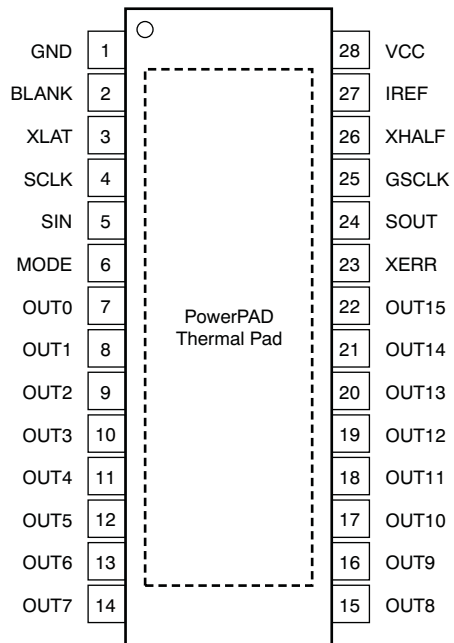

TERMINAL FUNCTIONS

TERMINAL		I/O	DESCRIPTION
NAME	PWP		
BLANK	2	I	Blank (all constant-current outputs off). When BLANK is high, all constant-current outputs (OUT0 through OUT15) are forced off, the Grayscale PWM timing controller initializes and the Grayscale counter resets to '0'. When BLANK is low, all constant-current outputs are controlled by the Grayscale PWM timing controller.
GND	1	—	Ground
GSCLK	25	I	Reference clock for Grayscale PWM control.
IREF	27	I/O	This pin sets the constant-current value. OUT0 through OUT15 sink constant-current is set to desired value by connecting an external resistor between IREF and GND.
MODE	6	I	Input mode pin. When MODE is high, the input mode is dot correction (DC). When MODE is low, the input mode is grayscale (GS).
NC	—	—	No connection
OUT0	7	O	Constant-current output
OUT1	8	O	Constant-current output
OUT2	9	O	Constant-current output
OUT3	10	O	Constant-current output
OUT4	11	O	Constant-current output
OUT5	12	O	Constant-current output
OUT6	13	O	Constant-current output
OUT7	14	O	Constant-current output
OUT8	15	O	Constant-current output
OUT9	16	O	Constant-current output
OUT10	17	O	Constant-current output
OUT11	18	O	Constant-current output
OUT12	19	O	Constant-current output
OUT13	20	O	Constant-current output
OUT14	21	O	Constant-current output
OUT15	22	O	Constant-current output
SCLK	4	I	Serial data shift clock
SIN	5	I	Serial data input
SOUT	24	O	Serial data output
VCC	28	I	Power-supply voltage
XERR	23	O	Error output. Open-drain output. XERR goes low when LOD or TEF is detected.
XHALF	26	I	Extended serial interface. When XHALF is high, the device operates normally. When XHALF is low, the extended serial interface is activated.
XLAT	3	I	Edge triggered latch signal. At the rising edge of XLAT, the TLC59461 writes data from the input shift register to either the Dot Correction register (MODE = high) or the Grayscale register (MODE = low).

PARAMETER MEASUREMENT INFORMATION

PIN EQUIVALENT INPUT AND OUTPUT SCHEMATIC DIAGRAMS

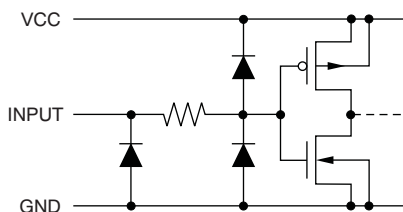

Figure 1. SIN, SCLK, GSCLK, XLAT, BLANK, MODE, XHALF

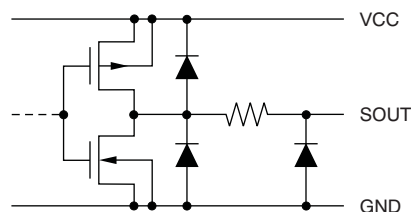

Figure 2. SOUT

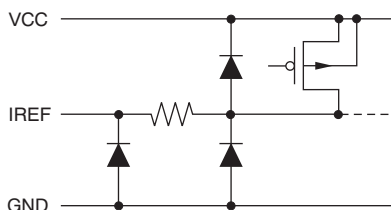

Figure 3. IREF

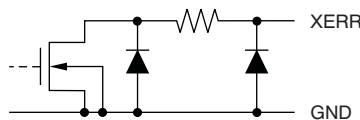

Figure 4. XERR

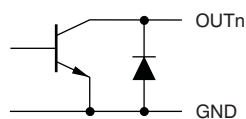
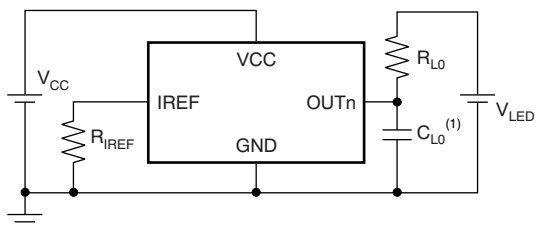

Figure 5. OUT0 Through OUT15

TEST CIRCUITS



(1) C_{L0} includes measurement probe and jig capacitance.

Figure 6. Rise Time and Fall Time Test Circuit for OUTn

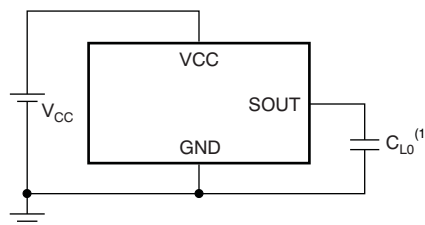

(1) C_{L0} includes measurement probe and jig capacitance.

Figure 7. Rise Time and Fall Time Test Circuit for SOUT

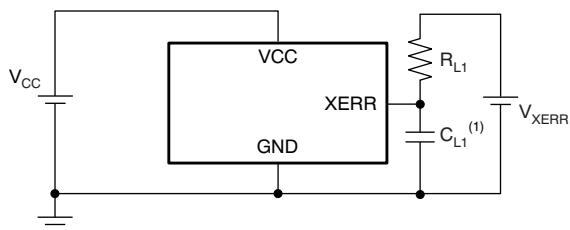

(1) C_{L1} includes measurement probe and jig capacitance.

Figure 8. Rise Time and Fall Time Test Circuit for XERR

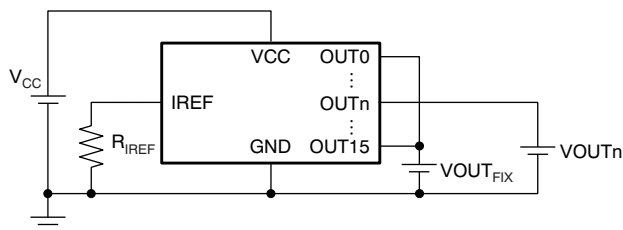
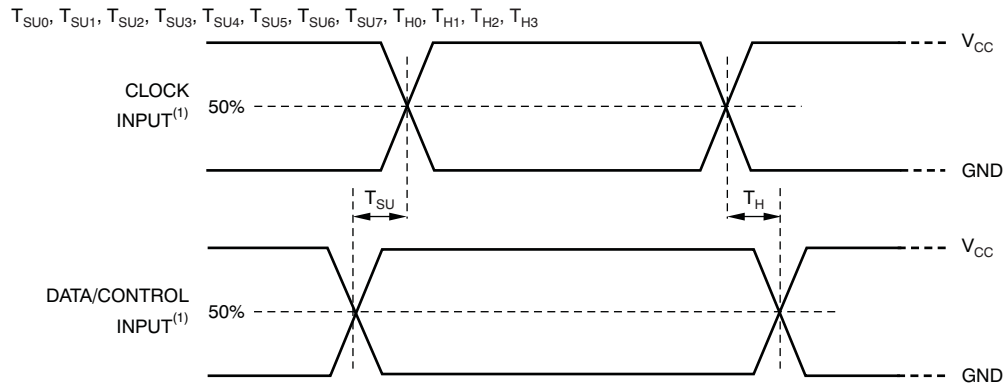
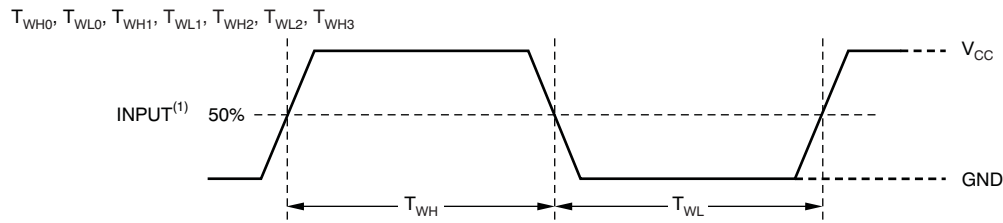

Figure 9. Constant-current Test Circuit for OUTn

TIMING DIAGRAMS



(1) Input pulse rise and fall time is 1 ns to 3 ns. Input pulse high level is VCC and low level is GND.

Figure 10. Input Timing

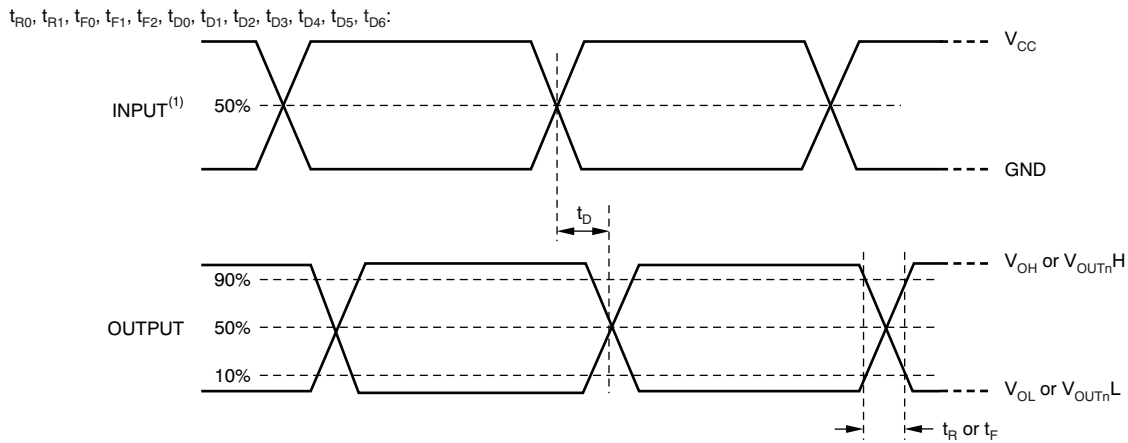

(1) Input pulse rise and fall time is 1 ns to 3 ns.

Figure 11. Output Timing

TYPICAL CHARACTERISTICS

At $V_{CC} = 3.3\text{ V}$ and $T_A = +25^\circ\text{C}$, unless otherwise noted.

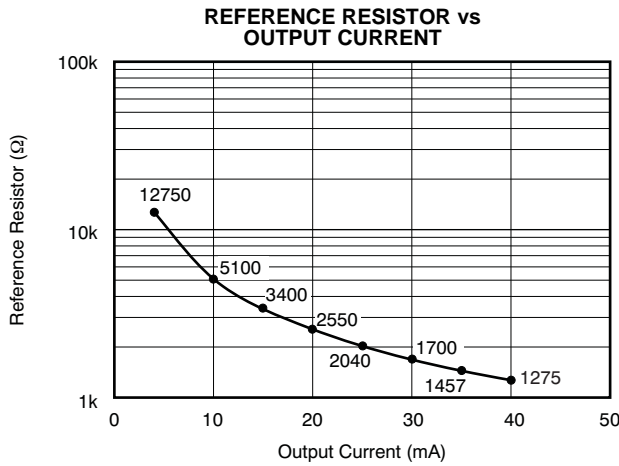

Figure 14.

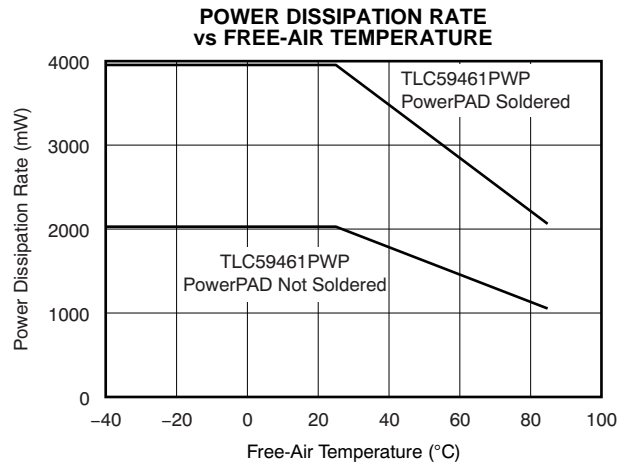

Figure 15.

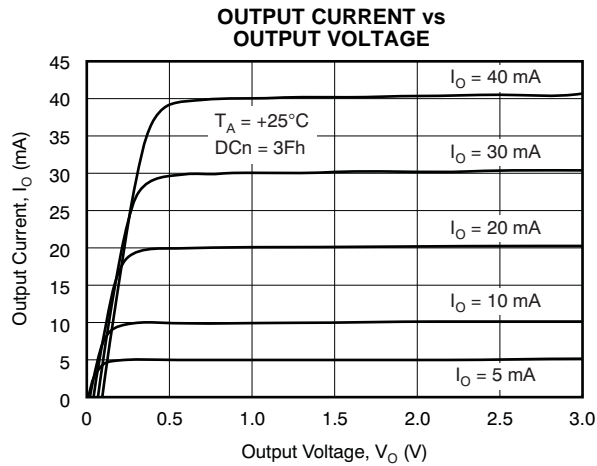

Figure 16.

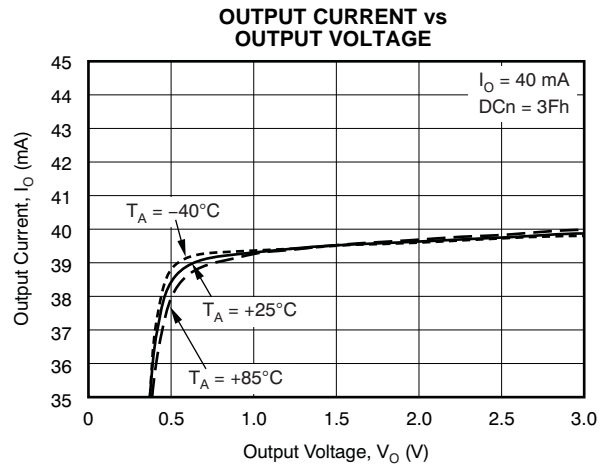

Figure 17.

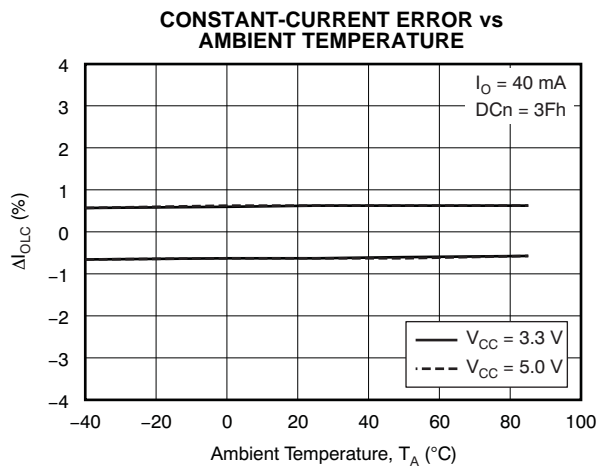

Figure 18.

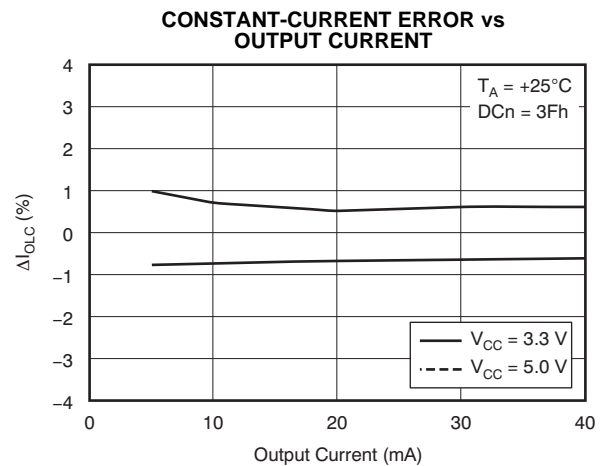

Figure 19.

TYPICAL CHARACTERISTICS (continued)

At $V_{CC} = 3.3\text{ V}$ and $T_A = +25^\circ\text{C}$, unless otherwise noted.

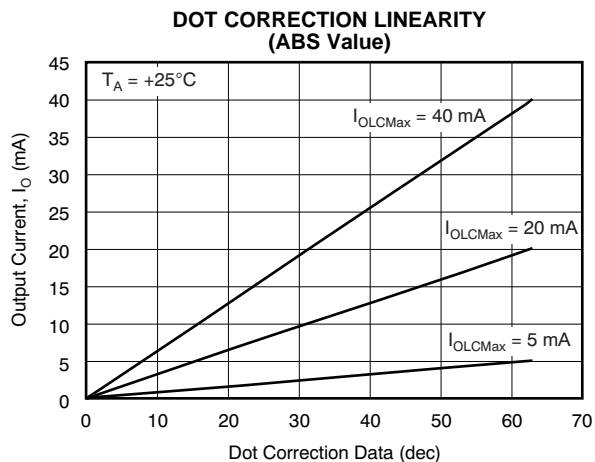

Figure 20.

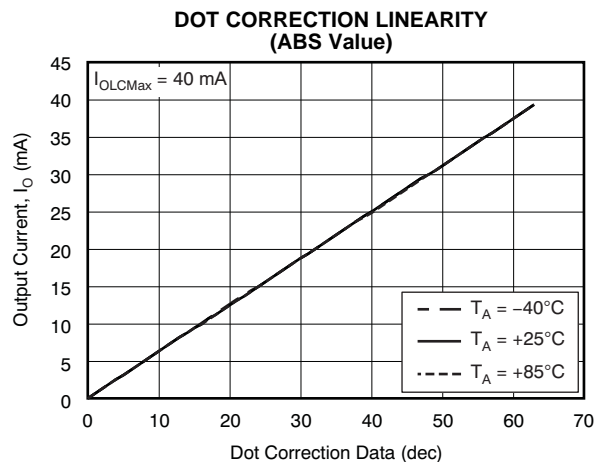

Figure 21.

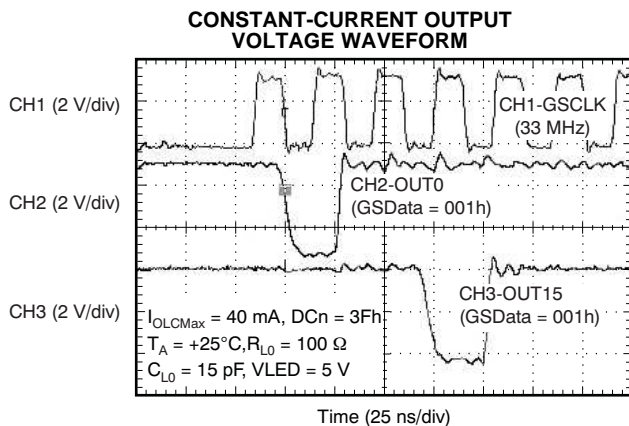

Figure 22.

DETAILED DESCRIPTION

SETTING FOR THE MAXIMUM OUTPUT CURRENT VALUE

The maximum output current of each channel (I_{OLCMax}) is set by a single external resistor (R_{IREF}), placed between the IREF pin and the GND pin. The voltage on IREF is generated with an internal bandgap, V_{IREF} , which has a typical value of 1.20 V. The R_{IREF} resistor value is calculated by [Equation 1](#):

$$R_{IREF} \text{ (k}\Omega\text{)} = 42.5 \times \frac{V_{IREF} \text{ (V)}}{I_{OLCMax} \text{ (mA)}} \quad (1)$$

Where:

- $V_{IREF} = 1.20 \text{ V}$
- $R_{IREF} = \text{User-selected external resistor}$

I_{OLCMax} is the largest current for all outputs. Each output sinks the I_{OLCMax} current when it is turned on and its dot correction is set to the maximum value of 3Fh (63d). The sink current for each output can be reduced by lowering the respective output dot correction value.

R_{IREF} must be between 1.275 k Ω (typ) and 12.75 k Ω (typ) in order to keep I_{OLCMax} between 4 mA and 40 mA. The output current may be unstable if I_{OLCMax} is less than 4 mA. Output currents lower than 4 mA can be achieved by setting I_{OLCMax} to 4 mA or higher and then using dot correction.

[Figure 14](#) illustrates the maximum output current versus R_{IREF} . R_{IREF} is the value of the resistor between the IREF terminal to GND. A variable power supply may be connected to the IREF pin through a resistor to change the maximum output current per output. The maximum output current is 42.5 times the current flowing out of the IREF pin.

DOT CORRECTION (DC) FUNCTION

The TLC59461 is able to individually adjust the output current of each channel (OUT0 to OUT15). This function is called *dot correction* (DC). The DC function allows the user to individually adjust the brightness and color deviations of LEDs connected to the outputs OUT0 to OUT15. Each respective channel output current can be adjusted in 64 steps from 0% to 100% of the maximum output current, I_{OLCMax} . Dot correction data are entered into the TLC59461 via the serial interface.

The output current is calculated by [Equation 2](#):

$$I_{OUTn} = I_{OLCMax} \times \frac{DCn}{63} \quad (2)$$

Where:

- I_{OLCMax} = the maximum output current of each output
- DCn = the programmed dot correction value of output n ($DCn = 0$ to 63)

When MODE is high, the input shift register works as a DC shift register. The shift registers and data latches are each 96 bits in length, and are used to individually adjust the constant-current values for each constant-current driver. Each channel can be adjusted from 0% to 100% of the maximum LED current with 6-bit resolution. [Figure 23](#) illustrates the DC serial data configuration. [Figure 12](#) illustrates the timing chart for writing data into the shift registers and data latches. Each channel LED current is dot-corrected by the percentage corresponding to the data in its DC data latch. DC data present on the SIN pin are clocked into the shift register with each rising edge of the SCLK pin. Data are shifted in MSB first. The data are latched from the shift register into the DC data latch with a rising edge on the XLAT pin.

The BLANK signal does not need to be high to latch in new data. When XLAT goes high, the new dot-correction data immediately become valid and change the output currents if the output is on. When the IC is powered on, the data in the shift register and DC data latch are not set to any default values. Therefore, DC data must be written to the DC latch before turning on the constant-current output.

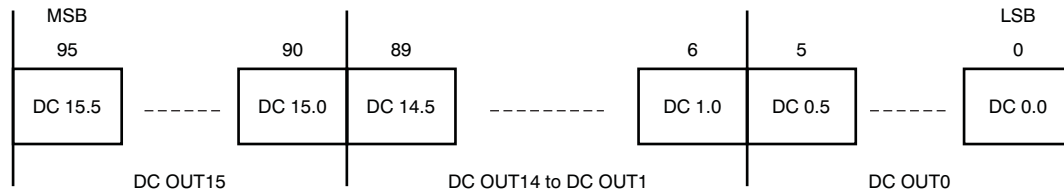

Figure 23. Dot Correction Serial Data Configuration

GRAYSCALE (GS) FUNCTION (PWM Operation)

Pulse width modulation (PWM) operation is controlled by a 12-bit grayscale counter that is clocked on each rising edge of the grayscale reference clock (GSCLK). The counter is reset to zero when the BLANK signal is set high. The counter value is held at zero while BLANK is high, even if the GSCLK input toggles high and low. After the falling edge of BLANK, the counter increments with each rising edge of GSCLK. Any constant-current sink output (OUT0 through OUT15) with a non-zero value in its corresponding grayscale latch starts to sink current after the first rising edge of GSCLK following a high-to-low transition of BLANK. The internal counter keeps track of the number of GSCLK pulses. Each output channel stays on as long as the internal counter is equal to or less than the respective output GS data. Each channel turns off at the rising edge of GSCLK when the grayscale counter value is larger than the grayscale latch value.

For example, an output that has a grayscale latch value of '1' turns on at the first rising edge of GSCLK after BLANK goes low. It turns off at the second rising edge of GSCLK. Figure 24 shows the PWM output timing. When the counter becomes FFFh, the counter stops and output does not turn on until the next grayscale cycle. Pulling BLANK high before the counter becomes FFFh immediately resets the counter to zero.

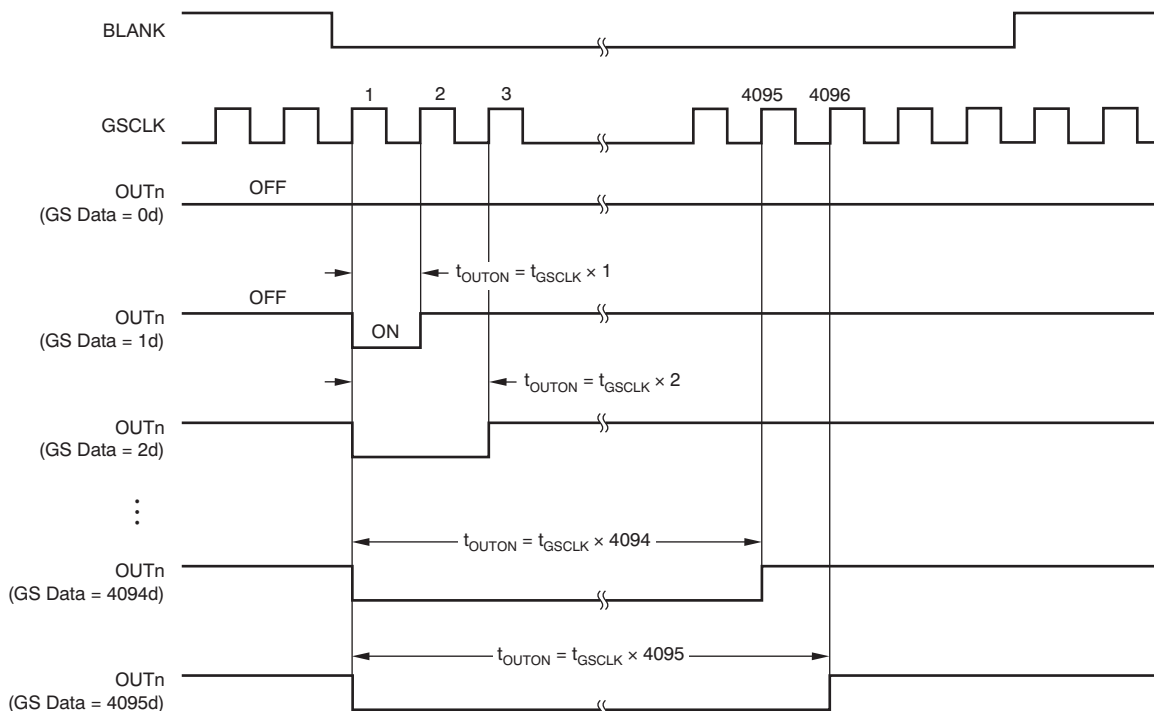

Figure 24. PWM Output Timing

When the IC powers on, the data in the shift register and latch are not set to any default value. Therefore, GS data must be written to the GS latch before turning the constant-current output on. Additionally, BLANK should be high when the device is powered on, to prevent the outputs from turning on before the proper grayscale and dot correction values are written. All constant-current outputs are always off when BLANK is high.

Each output (OUT_n) on-time (t_{OUTON}) is calculated by [Equation 3](#):

$$t_{\text{OUTON}} (\text{ns}) = t_{\text{GSCLK}} (\text{ns}) \times \text{GS}_n \quad (3)$$

Where:

- t_{GSCLK} = the period of GSCLK
- GS_n = the programmed grayscale value of output n ($\text{GS}_n = 0$ to $4095d$)

If XLAT goes high during a grayscale cycle, then new GS data are immediately latched into the GS latch. This action can cause the outputs to turn on or off unexpectedly. For proper operation, GS data should only be latched into the IC at the end of a GS period when BLANK is high.

When MODE is low, the input shift register works as a GS shift register. The shift registers and data latches are each 192 bits in length, and are used to set the PWM timing for each constant-current driver. [Figure 25](#) shows the GS serial data configuration. Refer to [Figure 12](#) for a timing diagram for writing data into the shift register and latch. The driver on-time is set by the data in the GS data latch. GS data present on the SIN pin are clocked into the shift register with each rising edge of the SCLK pin. Data are shifted in MSB first. Data are latched from the shift register into the GS data latch with a rising edge on the XLAT pin.

If there are any unconnected output LED lamps (including connection failures or short-circuits), the grayscale data corresponding to the unconnected output should be set to '0' before turning on the LEDs. Otherwise, the V_{CC} supply current (I_{VCC}) increases while the constant-current outputs are on.

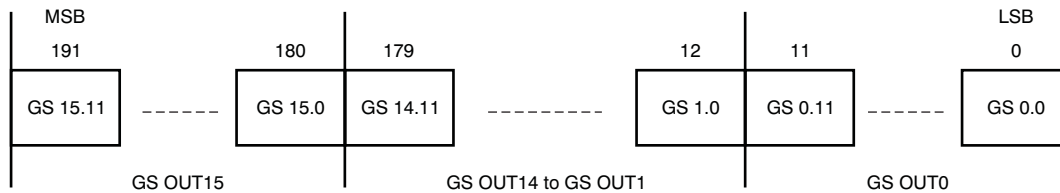

Figure 25. Grayscale Serial Data Configuration

STATUS INFORMATION DATA (SID)

Status information data (SID) are 17-bit, read-only data, accessible in the grayscale data input mode (MODE = GND). Both the LED open detection (LOD) error and the thermal error flag (TEF) are shifted out of the SOUT pin with each rising edge of SCLK. The 16 LOD bits for each channel and the TEF bit are written into the 17 most significant bits (MSBs) of the shift register at the rising edge of the first SCLK after XLAT goes high. As a result, the previous data in the 17 MSBs are lost at the same time. Figure 26 shows the bit assignments, Table 1 describes the SID data definition, and Figure 27 illustrates the read timing for the status information data.

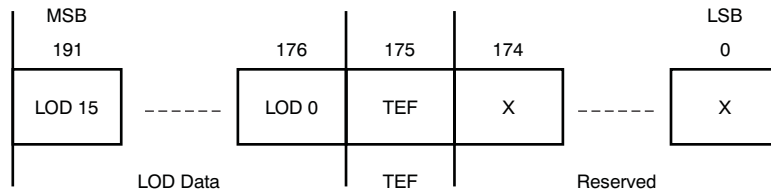

Figure 26. Status Information Data Configuration (XHALF = High)

Table 1. SID Data Definition

SID DATA	DEFINITION	
	LODn	TEF
0	No LED open error	No thermal error
1	LED is open or shorted to GND	Over temperature

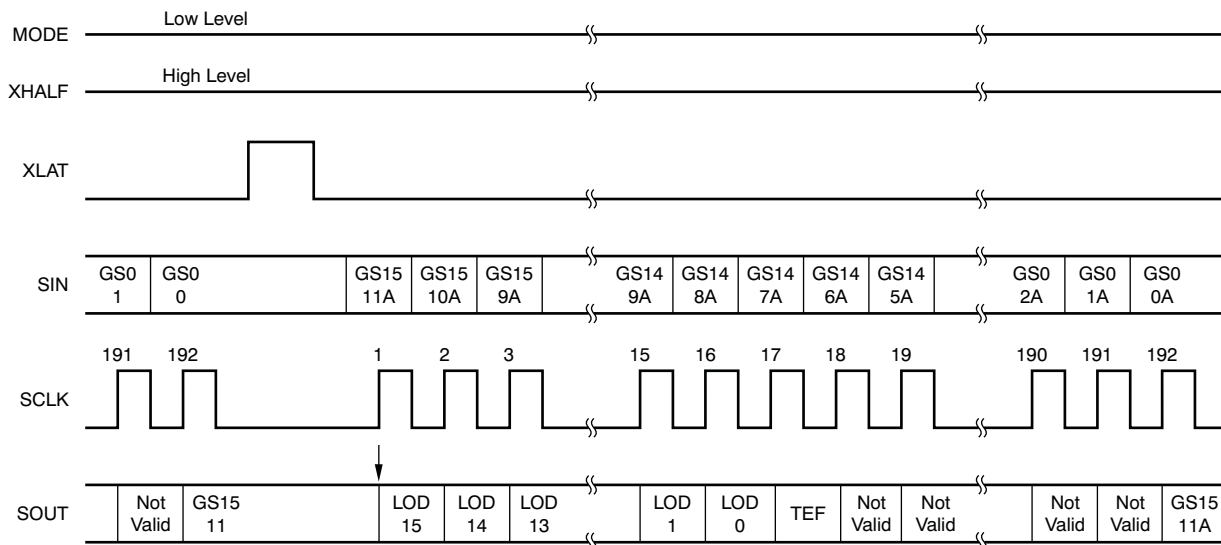

Figure 27. Status Information Data Read Timing (XHALF = High)

The LOD data are updated at the rising edge of the 33rd GSCLK pulse after BLANK goes low; the LOD data are retained until the next 33rd GSCLK. LOD data are only checked for outputs that are turned on during the rising edge of the 33rd GSCLK pulse. A '1' in a LOD bit indicates an open LED condition for the corresponding channel. A '0' indicates normal operation. The GS data should be equal to or higher than 21h (33d) to detect an open LED in every PWM cycle. When the IC is powered on, LOD data do not show correct values. Therefore, LOD data must be read at the rising edge of the 33rd GSCLK pulse after BLANK goes low.

The TEF bit indicates that the IC temperature is too high. A '1' in the TEF bit means that the IC temperature exceeds the detect temperature threshold, T_{TEF} . A '0' in the TEF bit indicates normal operating temperature conditions.

ERROR INFORMATION OUTPUT

The TLC59461 has two error detection circuits: LED open detection (LOD) and a thermal error flag (TEF). LOD detects a broken or disconnected LED during the display period. The TEF indicates an over-temperature condition. A low-level output of XERR indicates that an LOD error or TEF is detected. XERR pins of more than two ICs can be connected together and pulled up to V_{CC} with a single resistor because XERR is an open-drain output; see the [SCLK and GSCLK Frequency](#) section. [Table 2](#) shows the XERR truth table. BLANK = H masks LOD to distinguish between LOD and TEF. When the IC is powered on, XERR does not show correct values. XERR shows a correct signal when LOD data become valid at the rising edge of the 33rd GSCLK pulse after BLANK goes low. Also, both the LOD error and the TEF are shifted out of the SOUT pin; see the [Status Information Data \(SID\)](#) section.

Table 2. XERR Truth Table

CONDITION			XERR
ERROR DATA		INPUT	
LOD (Internal)	TEF (Internal)	BLANK	
0	0	L	H
0	1		L
1	0		L
1	1		L
0	0	H	H
0	1		L
1	0		H
1	1		L

CONTINUOUS BASE LED OPEN DETECTION (LOD)

The LOD function automatically updates LOD data at the rising edge of the 33rd GSCLK pulse after BLANK goes low; the LOD data are retained until the next 33rd GSCLK. LOD data are only checked for outputs that are turned on during the rising edge of the 33rd GSCLK pulse. The internal LOD data becomes '1' when the voltage of the OUTn pin is less than the LED open detection threshold ($V_{LOD} = 0.3$ V, typical).

To eliminate false detection of open LEDs, the LED driver design must ensure that the TLC59461 output voltage is greater than V_{LOD} when the outputs are on. The GS data should be greater than or equal to 21h (33d) to detect LED open in every PWM cycle.

AUTO OUTPUT OFF

The TLC59461 does not implement the Auto Output Off functionality that is available in the TLC5946. This revised architecture allows the voltage at the OUTn pins of the IC to be reduced to a voltage lower than the LED open detection threshold V_{LOD} (0.3V typical) specified in the [TLC5946 data sheet](#) and continue to have OUTn remain turned on. Reducing the voltage at OUTn minimizes the power dissipation in the IC.

THERMAL ERROR FLAG (TEF)

The TLC59461 has a thermal error flag (TEF) function to indicate an over-temperature condition. If the junction temperature exceeds the threshold temperature, +162°C typical, TEF toggles to '1' and the XERR pin goes to a low level. Once TEF becomes '1', it remains a '1' until the first falling edge of SCLK after XLAT goes high, as shown in [Figure 28](#). If the junction temperature (T_J) remains higher than the threshold temperature, TEF remains '1', even after the first falling edge of SCLK. TEF is also shifted out of the SOUT pin; see the [Status Information Data \(SID\)](#) section.

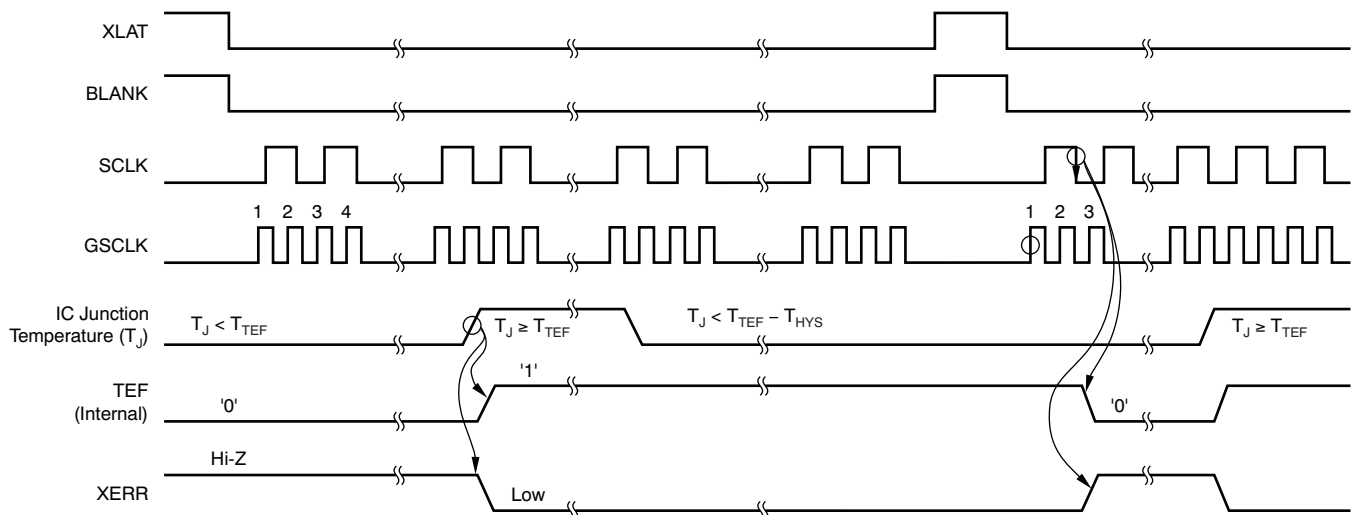

Figure 28. TEF and XERR Timing

NOISE REDUCTION

Large surge currents can flow through the IC and the board if all 16 LED channels fully turn on simultaneously at the start of each grayscale cycle. These large current surges could introduce detrimental noise and electromagnetic interference (EMI) into other circuits. The TLC59461 turns on the LED channels in a series delay, to provide a current soft-start feature. The output current sinks are grouped into four groups of four channels each. The first group is OUT0, 4, 8, 12; the second group is OUT1, 5, 9, 13; the third group is OUT2, 6, 10, 14; and the fourth group is OUT3, 7, 11, 15. Each group turns on sequentially with a small delay between groups; see [Figure 12](#). Both turn-on and turn-off are delayed.

OUTPUT ENABLE

When BLANK is high, all constant-current outputs turn off and the grayscale counter is reset. When BLANK is low, all constant-current outputs are controlled by the GS PWM timing controller. If BLANK goes low and then toggles high again in a very short time, all outputs that are programmed to turn on do so, for either the programmed number of grayscale clocks or the length of time that the BLANK signal was low, whichever is lower. For example, if all outputs are programmed to turn on for 1 ms, but the BLANK signal is only low for 50 ns, all outputs turn on for 50 ns, even though some outputs will turn on after the BLANK signal has already gone high.

SERIAL INTERFACE

The TLC59461 has a flexible serial interface that can be connected to microcontrollers or digital signal processors in various ways. Only three pins are needed to input data into the device. More than two TLC59461s can be connected in series by connecting an SOUT pin from one device to the SIN pin of the next device. Cascaded two TLC59461s are shown in [Figure 29](#) and [Figure 30](#). The SOUT pin can also be connected to the controller to receive status information from the TLC59461; see the [SCLK and GSCLK Frequency](#) section.

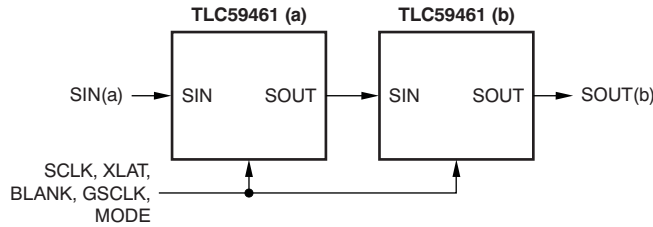

Figure 29. Cascading Two TLC59461 Devices

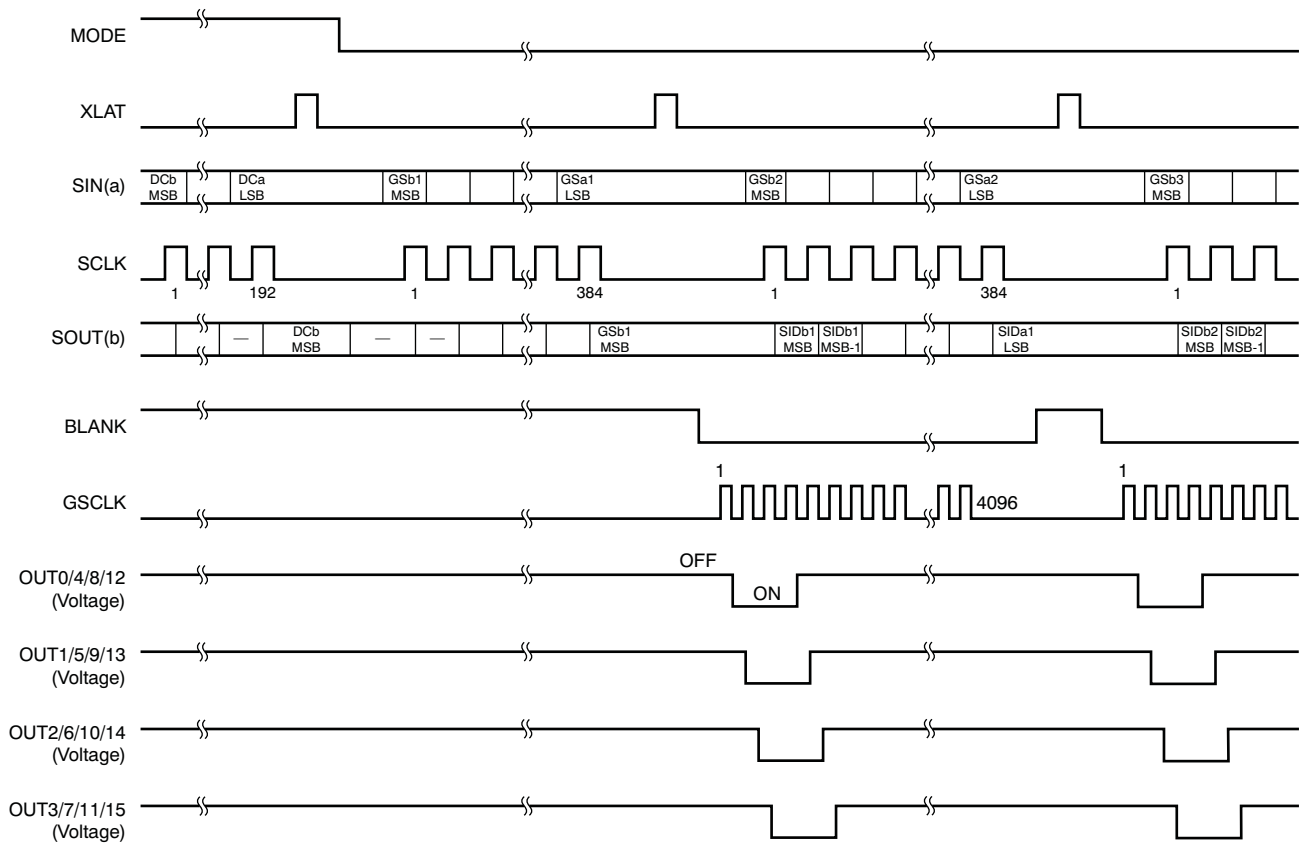

Figure 30. Timing Diagram of Two Cascaded TLC59461 Devices (XHALF = High)

SERIAL INTERFACE MODE

The serial interface has two input modes defined by the MODE pin, as Table 3 shows. XLAT must be low when the MODE pin goes high-to-low or low-to-high to change back and forth between GS mode and DC mode.

Table 3. Serial Interface Input Mode

MODE	INPUT MODE	INPUT SHIFT REGISTER
GND	Grayscale PWM data	192 bits
VCC	Dot correction data	96 bits

SCLK AND GSCLK FREQUENCY

Figure 31 shows a cascading connection of n TLC59461 devices connected to a single controller, building a basic module of an LED display system. There is no limitation to the maximum number of ICs that can be cascaded. However, the maximum number of cascading TLC59461 devices depends on the application system and is in the range of 40 devices. Equation 4 and Equation 5 show the minimum frequencies for GSCLK and SCLK.

$$f_{\text{GSCLK}} = 4096 \times f_{\text{UPDATE}} \quad (4)$$

$$f_{\text{SCLK}} = 192 \times f_{\text{UPDATE}} \times n \quad (5)$$

where:

- f_{GSCLK} = minimum frequency of GSCLK
- f_{SCLK} = minimum frequency of SCLK
- f_{UPDATE} = update rate of entire cascading system
- n = number of cascaded TLC59461 devices

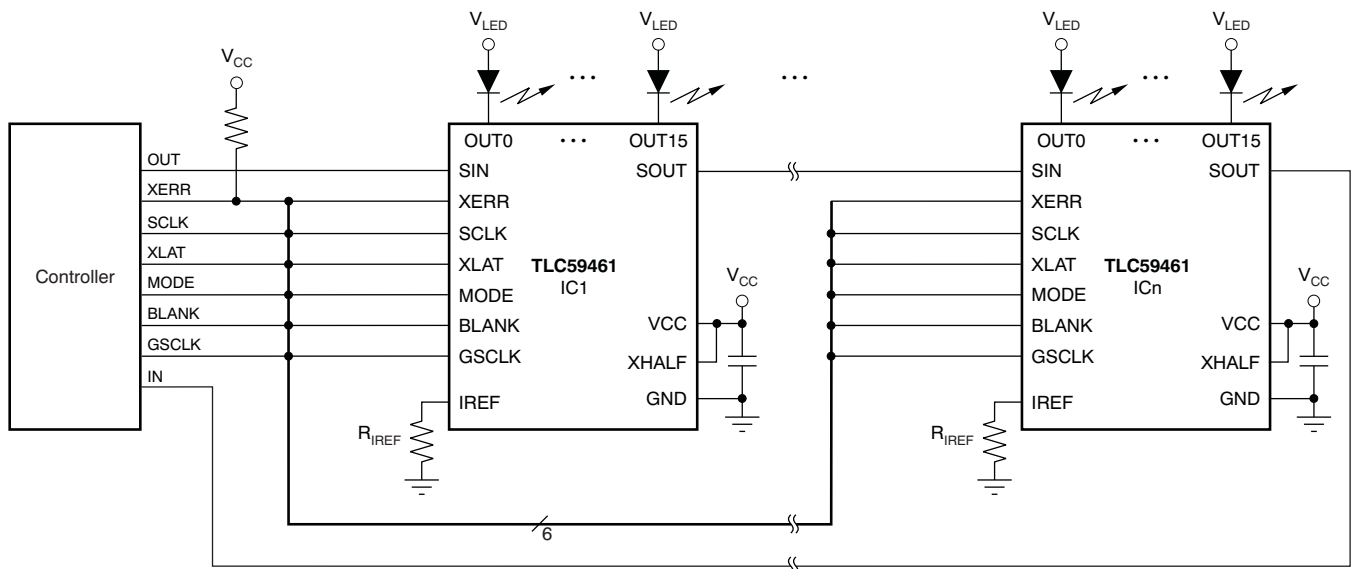

Figure 31. Cascading Device Connections

POWER DISSIPATION CALCULATION

The device power dissipation must be below the power dissipation rate of the device package to ensure correct operation. Equation 6 calculates the power dissipation of the device:

$$P_D = (V_{CC} \times I_{CC}) + \left[V_{OUT} \times I_{OLC_{max}} \times N \times \frac{DC_n}{63d} \times d_{PWM} \right] \quad (6)$$

Where:

- P_D = device power dissipation
- V_{CC} = device supply voltage
- I_{CC} = device supply current
- V_{OUT} = OUTn voltage when driving LED current
- $I_{OLC_{max}}$ = LED current adjusted by R_{IREF} resistor
- DC_n = maximum DC value for OUTn
- N = number of OUTn driving LED at the same time
- d_{PWM} = duty cycle defined by BLANK pin or GS PWM value

EXTENDED SERIAL INTERFACE

The TLC59461 has an extended serial interface with the following functions:

1. Independently accessible GS shift register of OUT0 to OUT7 or OUT8 to OUT15
2. SOUT half clock delay

When XHALF is low, the extended serial interface becomes active. Either the OUT0 to OUT7 GS shift register or the OUT8 to OUT15 GS shift register is selected in advance by counting the XLAT pulses while BLANK is high (one XLAT pulse selects the OUT0 to OUT7 GS shift register and two XLAT pulses select the OUT8 to OUT15 GS shift register), as shown in Figure 32. One or two XLAT pulses while BLANK is high must be input before sending the serial data.

SOUT outputs serial data at the falling edge of SCLK, delaying half a clock longer than the normal serial interface mode. SIN reads data at the rising edge of SCLK at the same as the normal serial interface mode. This configuration ensures a longer distance serial interface. Figure 33 shows the output timing of the extended serial interface mode.

SOUT outputs the status information data only when the data of OUT8 to OUT15 are shifted in, as shown in Figure 34 and Figure 35. The status information data configuration when XHALF is low is shown in Figure 36.

Figure 37 shows the recommended ac timing widths of the extended serial interface. Note that t_{WL2} , t_{SU7} , and t_{H3} are only effective when XHALF is low.

Figure 38 and Figure 39 show power-on sequence examples of this mode. BLANK should be high when the device is powered on to prevent the outputs from turning on before the proper GS and DC values are written. The extended serial interface mode is available only in the GS PWM mode (MODE = low). When MODE is high in the extended serial interface mode (XHALF = low), the TLC59461 becomes the DC mode that is the same as the normal DC mode.

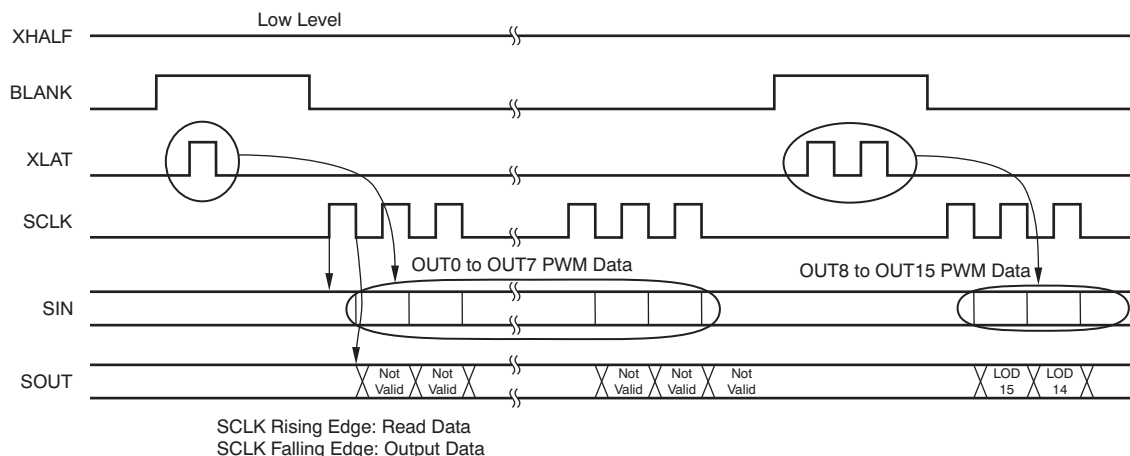

Figure 32. Extended Serial Interface

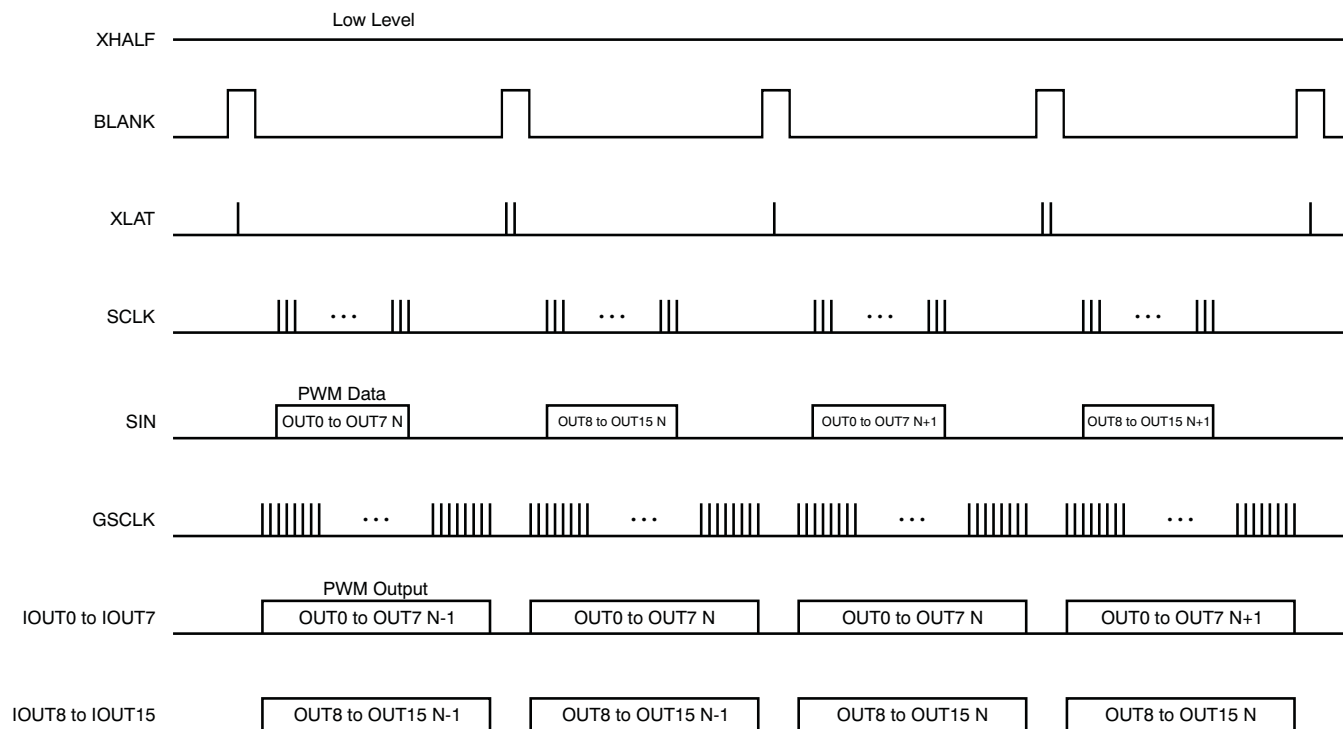

Figure 33. Output Timing of Extended Serial Interface

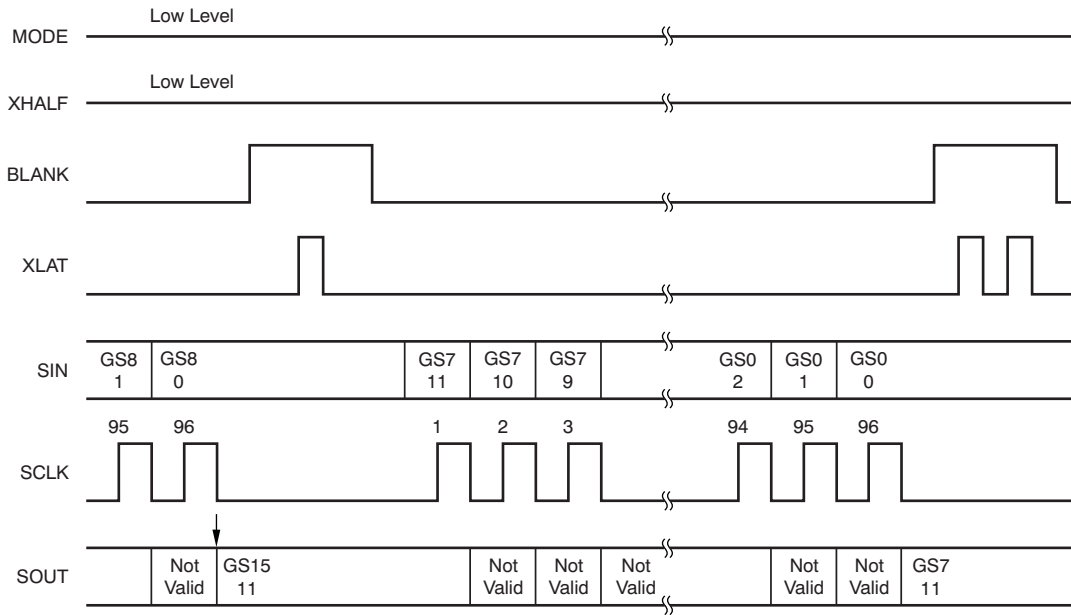

Figure 34. Extended Serial Interface (OUT0 to OUT7)

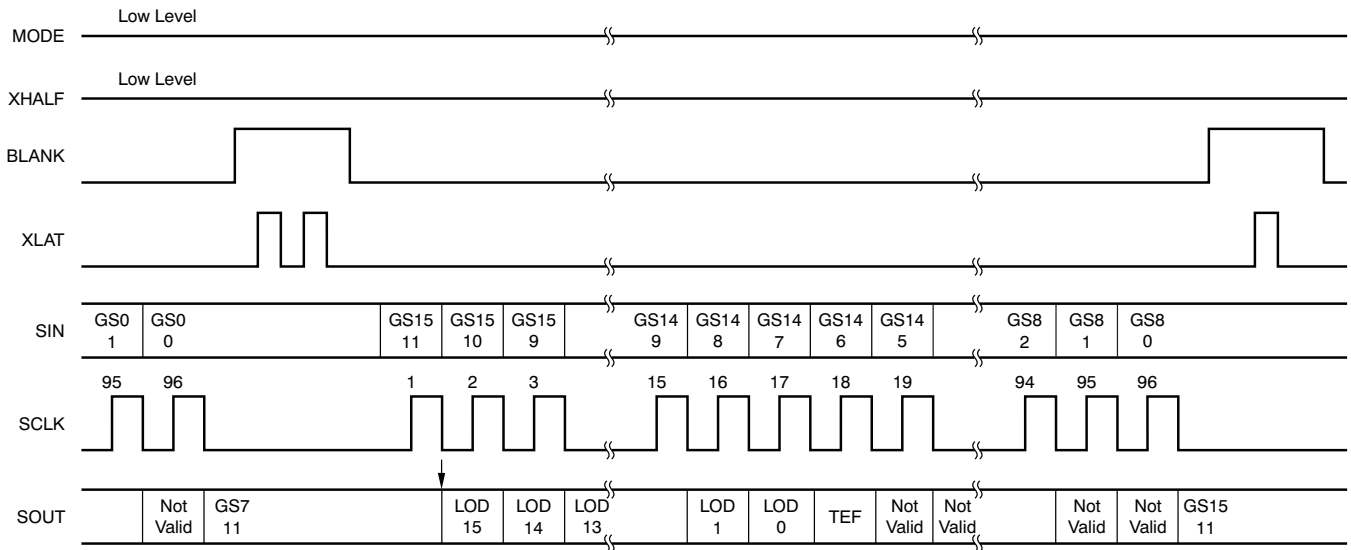

Figure 35. Extended Serial Interface (OUT8 to OUT15)

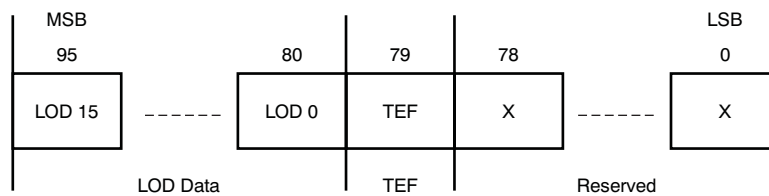

Figure 36. Status Information Data Configuration (XHALF = Low)

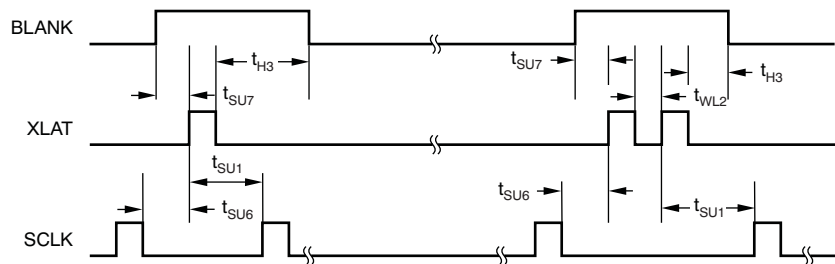

Figure 37. AC Timing in Extended Serial Interface Mode (XHALF = Low)

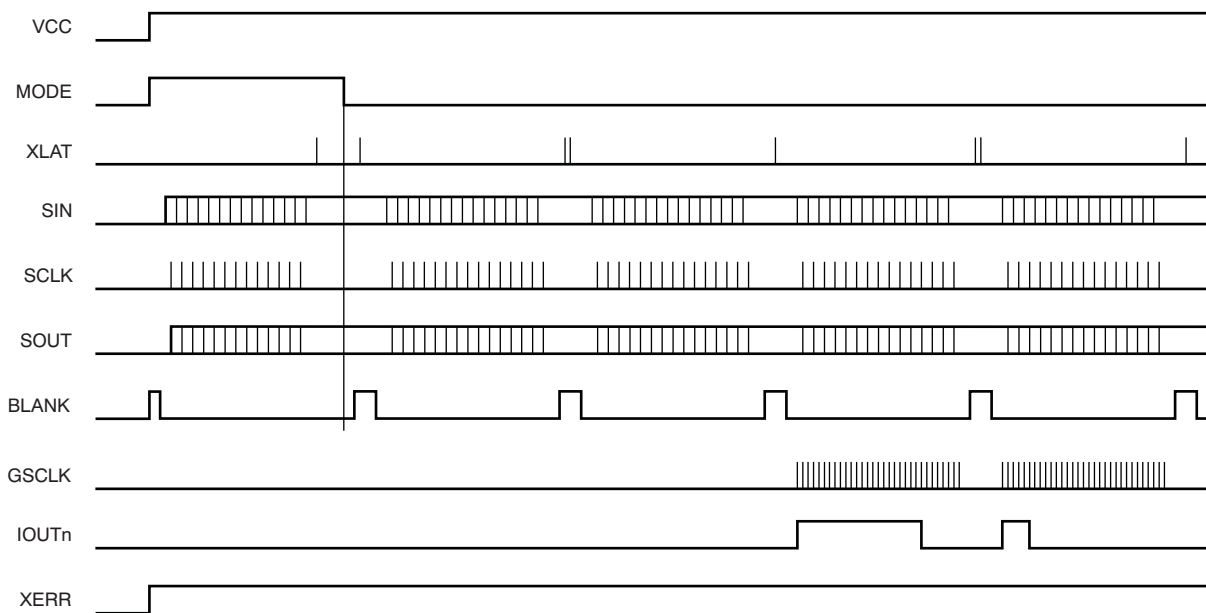
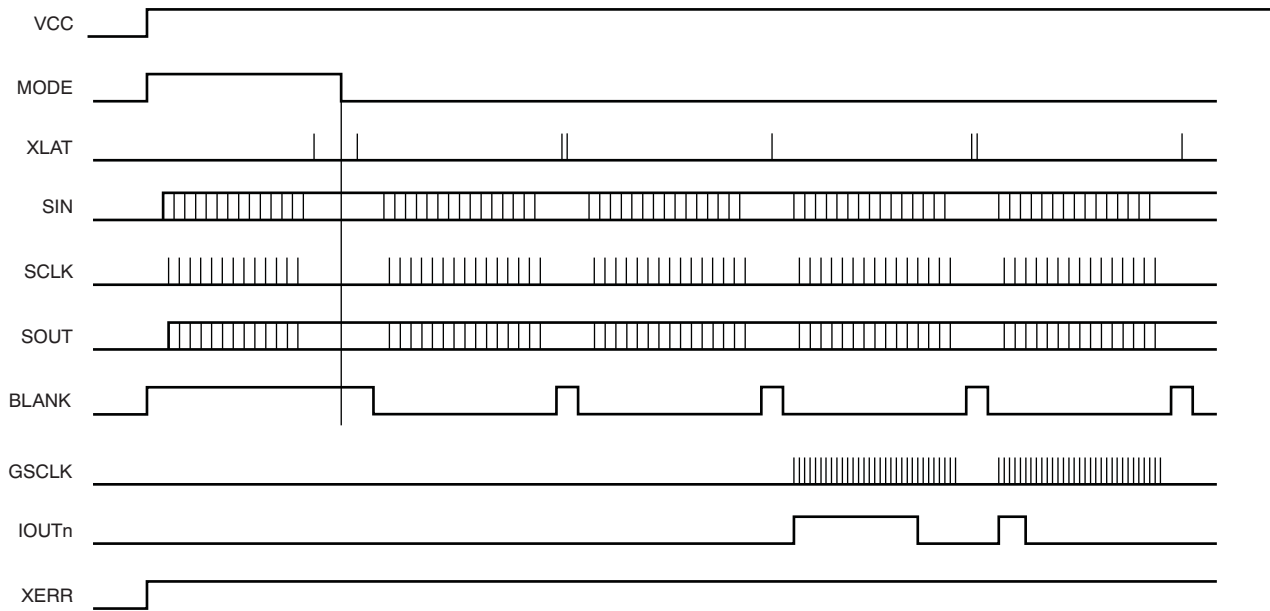

Figure 38. Power-On Sequence—1 (XHALF = Low)
(BLANK goes high immediately after power-on)



**Figure 39. Power-On Sequence—2 (XHALF = Low)
 (BLANK stays high after power-on, GS mode starts with BLANK = High)**

PACKAGING INFORMATION

Orderable Device	Status (1)	Package Type	Package Drawing	Pins	Package Qty	Eco Plan (2)	Lead finish/ Ball material (6)	MSL Peak Temp (3)	Op Temp (°C)	Device Marking (4/5)	Samples
TLC59461PWP	ACTIVE	HTSSOP	PWP	28	50	RoHS & Green	NIPDAU	Level-2-260C-1 YEAR	-40 to 85	TLC59461	Samples
TLC59461PWPR	ACTIVE	HTSSOP	PWP	28	2000	RoHS & Green	NIPDAU	Level-2-260C-1 YEAR	-40 to 85	TLC59461	Samples

(1) The marketing status values are defined as follows:

ACTIVE: Product device recommended for new designs.

LIFEBUY: TI has announced that the device will be discontinued, and a lifetime-buy period is in effect.

NRND: Not recommended for new designs. Device is in production to support existing customers, but TI does not recommend using this part in a new design.

PREVIEW: Device has been announced but is not in production. Samples may or may not be available.

OBSOLETE: TI has discontinued the production of the device.

(2) **RoHS:** TI defines "RoHS" to mean semiconductor products that are compliant with the current EU RoHS requirements for all 10 RoHS substances, including the requirement that RoHS substance do not exceed 0.1% by weight in homogeneous materials. Where designed to be soldered at high temperatures, "RoHS" products are suitable for use in specified lead-free processes. TI may reference these types of products as "Pb-Free".

RoHS Exempt: TI defines "RoHS Exempt" to mean products that contain lead but are compliant with EU RoHS pursuant to a specific EU RoHS exemption.

Green: TI defines "Green" to mean the content of Chlorine (Cl) and Bromine (Br) based flame retardants meet JS709B low halogen requirements of <=1000ppm threshold. Antimony trioxide based flame retardants must also meet the <=1000ppm threshold requirement.

(3) MSL, Peak Temp. - The Moisture Sensitivity Level rating according to the JEDEC industry standard classifications, and peak solder temperature.

(4) There may be additional marking, which relates to the logo, the lot trace code information, or the environmental category on the device.

(5) Multiple Device Markings will be inside parentheses. Only one Device Marking contained in parentheses and separated by a "~" will appear on a device. If a line is indented then it is a continuation of the previous line and the two combined represent the entire Device Marking for that device.

(6) Lead finish/Ball material - Orderable Devices may have multiple material finish options. Finish options are separated by a vertical ruled line. Lead finish/Ball material values may wrap to two lines if the finish value exceeds the maximum column width.

Important Information and Disclaimer:The information provided on this page represents TI's knowledge and belief as of the date that it is provided. TI bases its knowledge and belief on information provided by third parties, and makes no representation or warranty as to the accuracy of such information. Efforts are underway to better integrate information from third parties. TI has taken and continues to take reasonable steps to provide representative and accurate information but may not have conducted destructive testing or chemical analysis on incoming materials and chemicals. TI and TI suppliers consider certain information to be proprietary, and thus CAS numbers and other limited information may not be available for release.

In no event shall TI's liability arising out of such information exceed the total purchase price of the TI part(s) at issue in this document sold by TI to Customer on an annual basis.

TAPE AND REEL INFORMATION

QUADRANT ASSIGNMENTS FOR PIN 1 ORIENTATION IN TAPE



*All dimensions are nominal

Device	Package Type	Package Drawing	Pins	SPQ	Reel Diameter (mm)	Reel Width W1 (mm)	A0 (mm)	B0 (mm)	K0 (mm)	P1 (mm)	W (mm)	Pin1 Quadrant
TLC59461PWPR	HTSSOP	PWP	28	2000	330.0	16.4	6.9	10.2	1.8	12.0	16.0	Q1

TAPE AND REEL BOX DIMENSIONS

*All dimensions are nominal

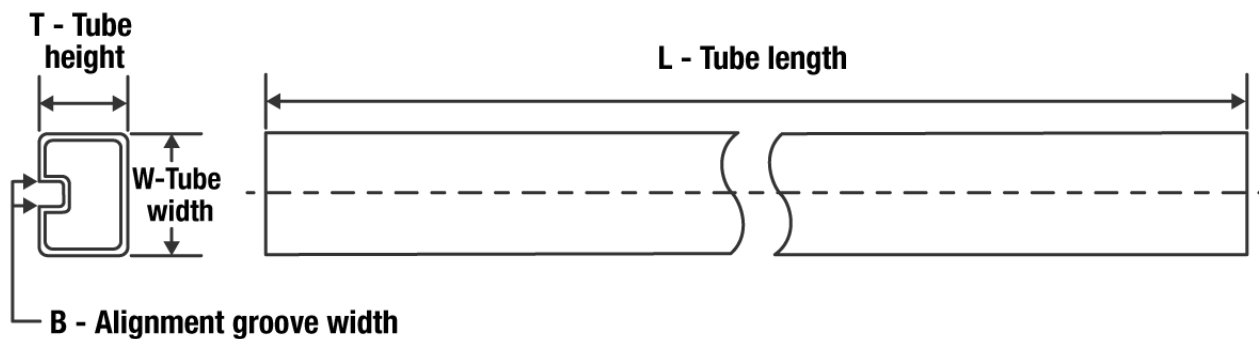
Device	Package Type	Package Drawing	Pins	SPQ	Length (mm)	Width (mm)	Height (mm)
TLC59461PWPR	HTSSOP	PWP	28	2000	367.0	367.0	38.0

TUBE

*All dimensions are nominal

Device	Package Name	Package Type	Pins	SPQ	L (mm)	W (mm)	T (μm)	B (mm)
TLC59461PWP	PWP	HTSSOP	28	50	530	10.2	3600	3.5

GENERIC PACKAGE VIEW

PWP 28

PowerPAD™ TSSOP - 1.2 mm max height

4.4 x 9.7, 0.65 mm pitch

SMALL OUTLINE PACKAGE

This image is a representation of the package family, actual package may vary.
Refer to the product data sheet for package details.

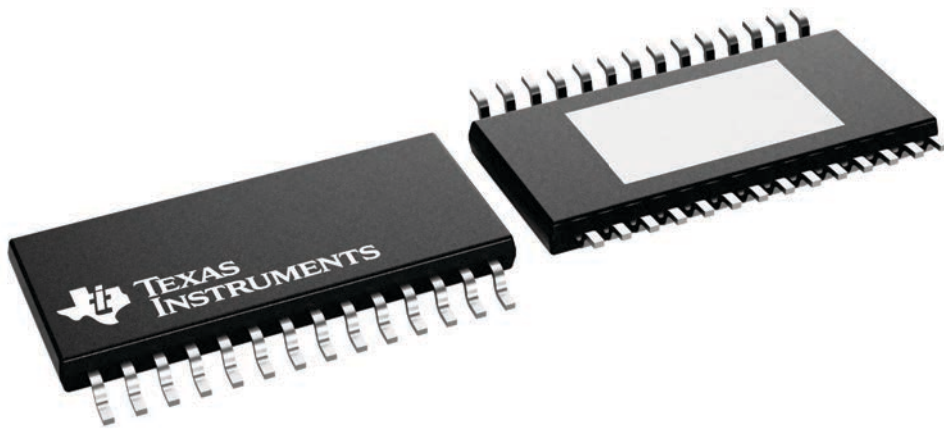

4224765/B

MECHANICAL DATA

PWP (R-PDSO-G28)

PowerPAD™ PLASTIC SMALL OUTLINE

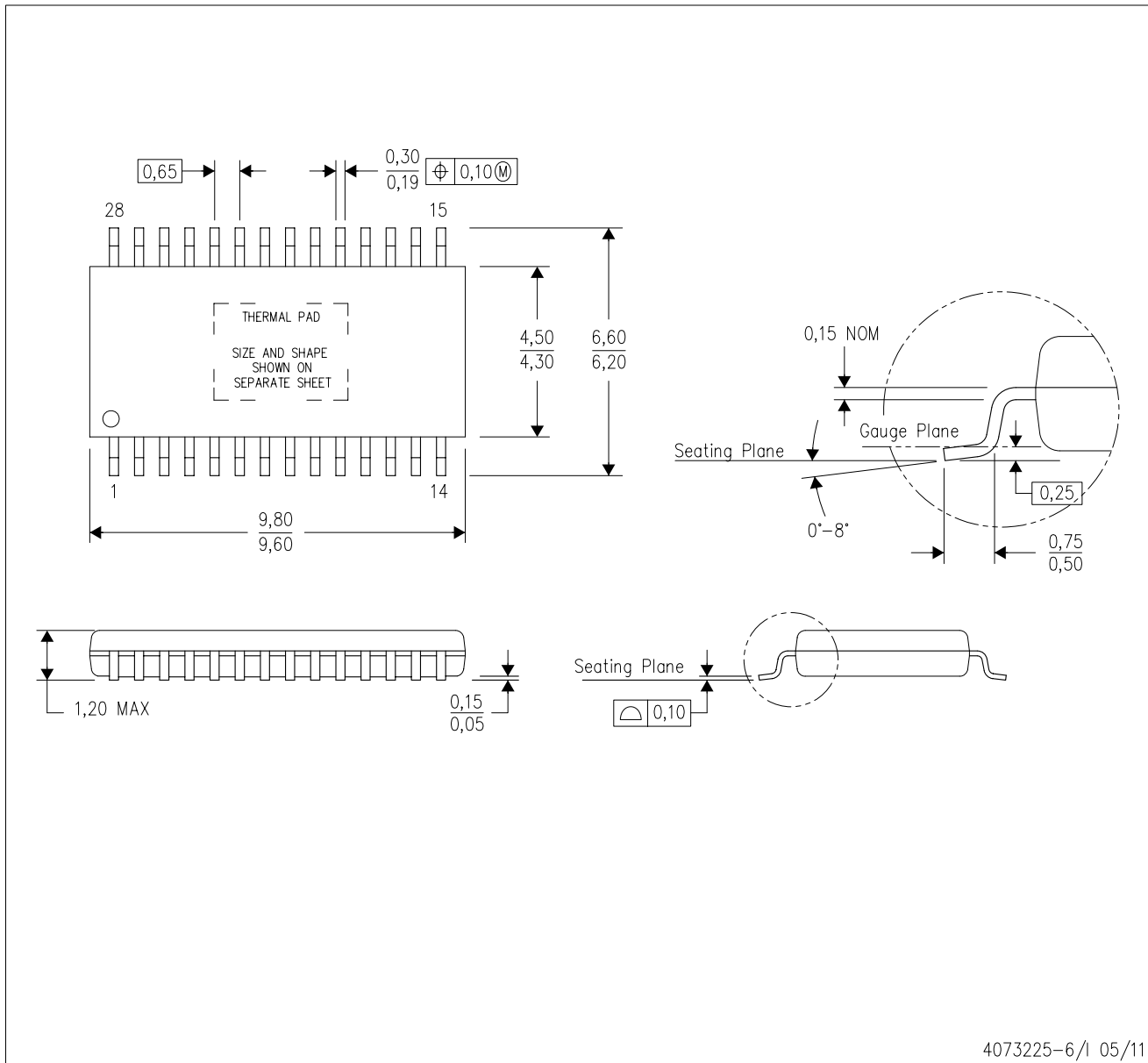

4073225-6/1 05/11

- NOTES:
- All linear dimensions are in millimeters.
 - This drawing is subject to change without notice.
 - Body dimensions do not include mold flash or protrusions. Mold flash and protrusion shall not exceed 0.15 per side.
 - This package is designed to be soldered to a thermal pad on the board. Refer to Technical Brief, PowerPad Thermally Enhanced Package, Texas Instruments Literature No. SLMA002 for information regarding recommended board layout. This document is available at www.ti.com <<http://www.ti.com>>.
 - See the additional figure in the Product Data Sheet for details regarding the exposed thermal pad features and dimensions.
 - Falls within JEDEC MO-153

PowerPAD is a trademark of Texas Instruments.

THERMAL PAD MECHANICAL DATA

PWP (R-PDSO-G28) PowerPAD™ SMALL PLASTIC OUTLINE

THERMAL INFORMATION

This PowerPAD™ package incorporates an exposed thermal pad that is designed to be attached to a printed circuit board (PCB). The thermal pad must be soldered directly to the PCB. After soldering, the PCB can be used as a heatsink. In addition, through the use of thermal vias, the thermal pad can be attached directly to the appropriate copper plane shown in the electrical schematic for the device, or alternatively, can be attached to a special heatsink structure designed into the PCB. This design optimizes the heat transfer from the integrated circuit (IC).

For additional information on the PowerPAD package and how to take advantage of its heat dissipating abilities, refer to Technical Brief, PowerPAD Thermally Enhanced Package, Texas Instruments Literature No. SLMA002 and Application Brief, PowerPAD Made Easy, Texas Instruments Literature No. SLMA004. Both documents are available at www.ti.com.

The exposed thermal pad dimensions for this package are shown in the following illustration.

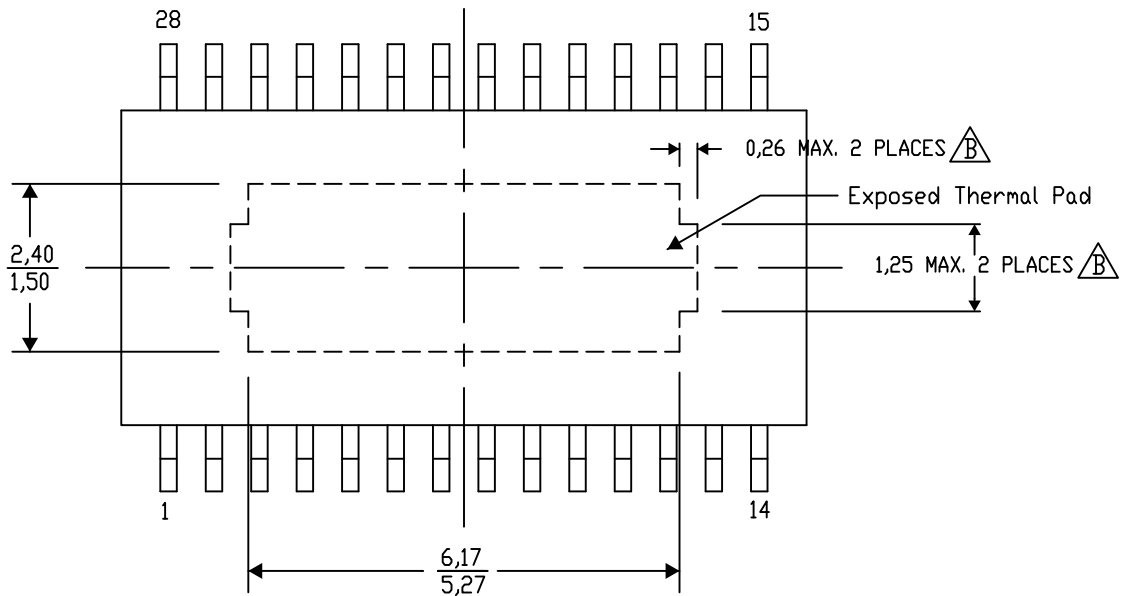

Top View

Exposed Thermal Pad Dimensions

4206332-33/AO 01/16

NOTE: A. All linear dimensions are in millimeters

B. Exposed tie strap features may not be present.

PowerPAD is a trademark of Texas Instruments

PWP (R-PDSO-G28)

PowerPAD™ PLASTIC SMALL OUTLINE

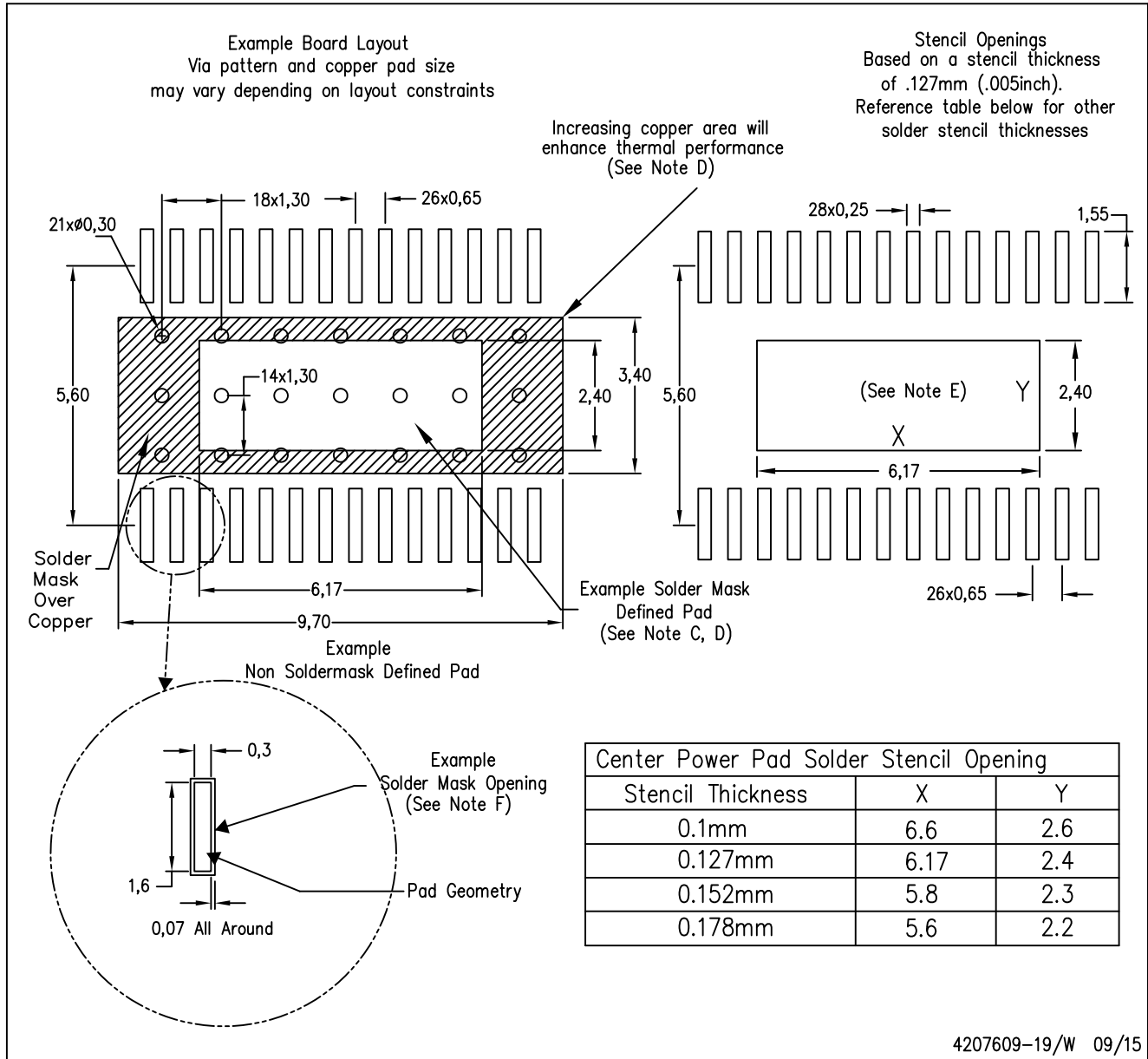

NOTES:

- A. All linear dimensions are in millimeters.
- B. This drawing is subject to change without notice.
- C. Customers should place a note on the circuit board fabrication drawing not to alter the center solder mask defined pad.
- D. This package is designed to be soldered to a thermal pad on the board. Refer to Technical Brief, PowerPad Thermally Enhanced Package, Texas Instruments Literature No. SLMA002, SLMA004, and also the Product Data Sheets.
- E. For specific thermal information, via requirements, and recommended board layout. These documents are available at www.ti.com <<http://www.ti.com>>. Publication IPC-7351 is recommended for alternate designs. Laser cutting apertures with trapezoidal walls and also rounding corners will offer better paste release. Customers should contact their board assembly site for stencil design recommendations. Example stencil design based on a 50% volumetric metal load solder paste. Refer to IPC-7525 for other stencil
- F. Customers should contact their board fabrication site for solder mask tolerances between and around signal pads.

IMPORTANT NOTICE AND DISCLAIMER

TI PROVIDES TECHNICAL AND RELIABILITY DATA (INCLUDING DATA SHEETS), DESIGN RESOURCES (INCLUDING REFERENCE DESIGNS), APPLICATION OR OTHER DESIGN ADVICE, WEB TOOLS, SAFETY INFORMATION, AND OTHER RESOURCES "AS IS" AND WITH ALL FAULTS, AND DISCLAIMS ALL WARRANTIES, EXPRESS AND IMPLIED, INCLUDING WITHOUT LIMITATION ANY IMPLIED WARRANTIES OF MERCHANTABILITY, FITNESS FOR A PARTICULAR PURPOSE OR NON-INFRINGEMENT OF THIRD PARTY INTELLECTUAL PROPERTY RIGHTS.

These resources are intended for skilled developers designing with TI products. You are solely responsible for (1) selecting the appropriate TI products for your application, (2) designing, validating and testing your application, and (3) ensuring your application meets applicable standards, and any other safety, security, regulatory or other requirements.

These resources are subject to change without notice. TI grants you permission to use these resources only for development of an application that uses the TI products described in the resource. Other reproduction and display of these resources is prohibited. No license is granted to any other TI intellectual property right or to any third party intellectual property right. TI disclaims responsibility for, and you will fully indemnify TI and its representatives against, any claims, damages, costs, losses, and liabilities arising out of your use of these resources.

TI's products are provided subject to [TI's Terms of Sale](#) or other applicable terms available either on ti.com or provided in conjunction with such TI products. TI's provision of these resources does not expand or otherwise alter TI's applicable warranties or warranty disclaimers for TI products.

TI objects to and rejects any additional or different terms you may have proposed.

Mailing Address: Texas Instruments, Post Office Box 655303, Dallas, Texas 75265
Copyright © 2022, Texas Instruments Incorporated