

具有可编程延迟的 TPS3890-Q1 低静态电流、1% 精度监控器

1 特性

- 符合汽车应用 标准
- 具有符合 AEC-Q100 标准的下列特性：
 - 器件温度等级 1: -40°C 至 125°C 的环境运行温度范围
 - 器件 HBM ESD 分类等级 2
 - 器件 CDM ESD 分类等级 C4B
- 上电复位 (POR) 发生器具有可调延迟时间: 25 μ s 到 30s
- 极低电源电流: 2.1 μ A (典型值)
- 高阈值精度: 1% (最大值)
- 高精度迟滞
- 固定和可调节阈值电压:
 - 标准电压轨的固定阈值为: 1.2V 到 5V
 - 可调节阈值电压低至 1.15V
- 手动复位 ($\overline{\text{MR}}$) 输入
- 开漏 $\overline{\text{RESET}}$ 输出
- 温度范围: -40°C 至 +125°C
- 封装: 1.5mm x 1.5mm 晶圆级小外形无引线 (WSON) 封装

2 应用

- 信息娱乐系统音响主机
- 混合/数字仪表盘组
- 外部放大器
- ADAS 摄像头
- 汽车网关

典型应用电路

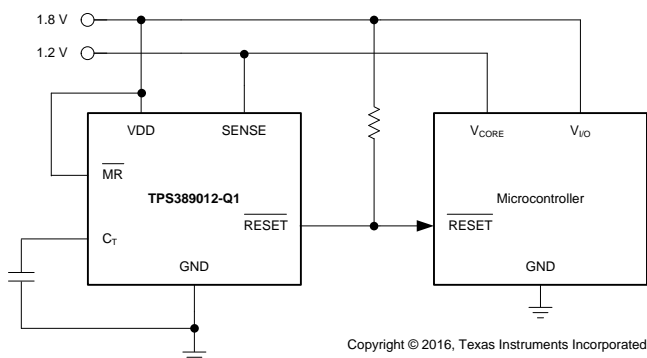

3 说明

TPS3890-Q1 是一款具有较低静态电流的高精度电压监控器，可监视低至 1.15V 的系统电压，在 SENSE 电压降至低于预设阈值或手动复位 ($\overline{\text{MR}}$) 引脚降为逻辑低电平时发出开漏 $\overline{\text{RESET}}$ 信号。在 SENSE 电压和手动复位 ($\overline{\text{MR}}$) 返回至相应阈值以上之后， $\overline{\text{RESET}}$ 输出会在用户可调节延迟时间内保持低电平。TPS3890-Q1 系列采用高精度电压基准，可实现 1% 的阈值精度。通过将 CT 引脚与外部电容器相连，用户可在 25 μ s 到 30s 范围内调节复位延迟时间。TPS3890-Q1 具有 2.1 μ A 的极低静态电流，采用 1.5mm x 1.5mm 小型封装，非常适用于电池供电和空间受限应用供电的绝佳器件。该器件的额定工作温度范围为 -40°C 至 +125°C (T_J)。

器件信息⁽¹⁾

器件型号	封装	封装尺寸 (标称值)
TPS3890-Q1	WSON (6)	1.50mm x 1.50mm

(1) 如需了解所有可用封装，请参阅产品说明书末尾的可订购产品附录。

V_{ITN} 精度与温度间的关系

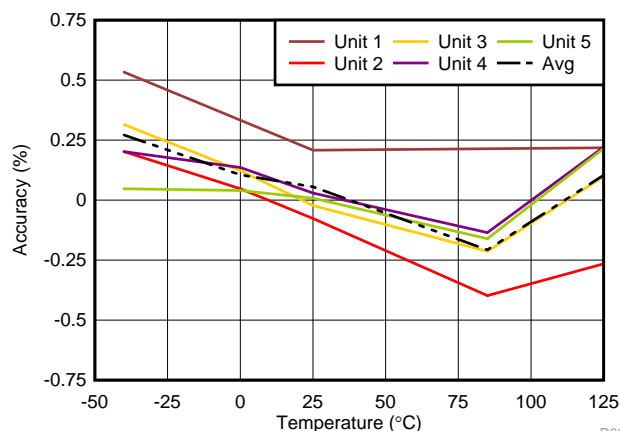

D001



目录

1	特性	1	8.4	Device Functional Modes.....	14
2	应用	1	9	Application and Implementation	15
3	说明	1	9.1	Application Information.....	15
4	修订历史记录	2	9.2	Typical Application	15
5	Device Comparison Table	3	10	Power Supply Recommendations	16
6	Pin Configuration and Functions	3	11	Layout	17
7	Specifications	4	11.1	Layout Guidelines	17
7.1	Absolute Maximum Ratings	4	11.2	Layout Example	17
7.2	ESD Ratings	4	12	器件和文档支持	18
7.3	Recommended Operating Conditions.....	4	12.1	器件支持	18
7.4	Thermal Information	4	12.2	文档支持	18
7.5	Electrical Characteristics.....	5	12.3	接收文档更新通知	18
7.6	Timing Requirements	5	12.4	社区资源	18
7.7	Typical Characteristics	7	12.5	商标	19
8	Detailed Description	11	12.6	静电放电警告.....	19
8.1	Overview	11	12.7	Glossary	19
8.2	Functional Block Diagram	11	13	机械、封装和可订购信息	19
8.3	Feature Description.....	11			

4 修订历史记录

Changes from Revision A (October 2017) to Revision B	Page
• 已添加 汽车 特性	1
• Added new voltage options to Device Comparison Table.....	3

Changes from Original (March 2017) to Revision A	Page
• Added TPS389050L-Q1 to Device Comparison Table	3

5 Device Comparison Table

PART NUMBER	NOMINAL SUPPLY VOLTAGE	NEGATIVE THRESHOLD (V_{ITN})	POSITIVE THRESHOLD (V_{ITP})
TPS389001-Q1	Adjustable	1.15 V	1.157 V
TPS389012-Q1	1.2 V	1.15 V	1.157 V
TPS389015-Q1	1.5 V	1.44 V	1.449 V
TPS389018-Q1	1.8 V	1.73 V	1.740 V
TPS389025-Q1	2.5 V	2.40 V	2.414 V
TPS389030-Q1	3.0 V	2.89 V	2.907 V
TPS389033-Q1	3.3 V	3.17 V	3.189 V
TPS389033G-Q1	3.3 V	3.06 V	3.084 V
TPS389033K-Q1	3.3 V	2.93 V	2.947 V
TPS389050-Q1	5.0 V	4.80 V	4.828 V
TPS389050G-Q1	5.0 V	4.65 V	4.677 V
TPS389050L-Q1	5.0 V	4.40 V	4.425 V

6 Pin Configuration and Functions

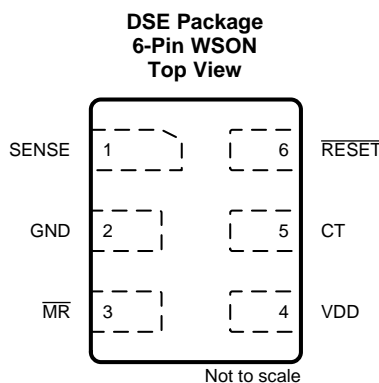

Pin Functions

PIN		I/O	DESCRIPTION
NO.	NAME		
1	SENSE	I	This pin is connected to the voltage to be monitored. When the voltage on SENSE falls below the negative threshold voltage V_{ITN} , $\overline{\text{RESET}}$ goes low (asserts). When the voltage on SENSE rises above the positive threshold voltage V_{ITP} , $\overline{\text{RESET}}$ goes high (deasserts).
2	GND	—	Ground
3	$\overline{\text{MR}}$	I	Driving the manual reset pin ($\overline{\text{MR}}$) low causes $\overline{\text{RESET}}$ to go low (assert).
4	VDD	I	Supply voltage pin. Good analog design practice is to place a 0.1- μF ceramic capacitor close to this pin.
5	CT	—	The CT pin offers a user-adjustable delay time. Connecting this pin to a ground-referenced capacitor sets the $\overline{\text{RESET}}$ delay time to deassert. $t_{PD(f)}$ (sec) = C_{CT} (μF) \times 1.07 + 25 μs (nom).
6	$\overline{\text{RESET}}$	O	$\overline{\text{RESET}}$ is an open-drain output that is driven to a low-impedance state when either the $\overline{\text{MR}}$ pin is driven to a logic low or the monitored voltage on the SENSE pin is lower than the negative threshold voltage (V_{ITN}). $\overline{\text{RESET}}$ remains low (asserted) for the delay time period after both $\overline{\text{MR}}$ is set to a logic high and the SENSE input is above V_{ITP} . A pullup resistor from 10 k Ω to 1 M Ω should be used on this pin.

7 Specifications

7.1 Absolute Maximum Ratings

over operating junction temperature range (unless otherwise noted)⁽¹⁾

		MIN	MAX	UNIT
Voltage	V _{DD}	-0.3	7	V
	SENSE	-0.3	7	
	RESET	-0.3	7	
	MR	-0.3	7	
	V _{CT}	-0.3	7	
Current	RESET	-20	20	mA
Temperature	Operating junction, T _J	-40	125	°C
	Operating ambient, T _A	-40	125	
	Storage, T _{stg}	-65	150	

- (1) Stresses beyond those listed under *Absolute Maximum Ratings* may cause permanent damage to the device. These are stress ratings only, which do not imply functional operation of the device at these or any other conditions beyond those indicated under *Recommended Operating Conditions*. Exposure to absolute-maximum-rated conditions for extended periods may affect device reliability.

7.2 ESD Ratings

		VALUE	UNIT
V _(ESD) Electrostatic discharge	Human-body model (HBM), per AEC Q100-002 ⁽¹⁾	±2000	V
	Charged-device model (CDM), per AEC Q100-011	±750	

- (1) AEC Q100-002 indicates that HBM stressing shall be in accordance with the ANSI/ESDA/JEDEC JS-001 specification.

7.3 Recommended Operating Conditions

over operating free-air temperature range (unless otherwise noted)

		MIN	NOM	MAX	UNIT
V _{DD}	Power-supply voltage	1.5		5.5	V
V _{SENSE}	SENSE voltage	0		5.5	V
V _{RESET}	RESET pin voltage	0		5.5	V
I _{RESET}	RESET pin current	-5		5	mA
C _{IN}	Input capacitor, V _{DD} pin	0	0.1		μF
C _{CT}	Reset timeout capacitor, CT pin	0		26	μF
R _{PU}	Pullup resistor, RESET pin	1		1000	kΩ
T _J	Junction temperature (free-air temperature)	-40	25	125	°C

7.4 Thermal Information

THERMAL METRIC ⁽¹⁾		TPS3890-Q1	UNIT
		DSE (WSO)	
		6 PINS	
R _{θJA}	Junction-to-ambient thermal resistance	321.3	°C/W
R _{θJC(top)}	Junction-to-case (top) thermal resistance	207.9	°C/W
R _{θJB}	Junction-to-board thermal resistance	281.5	°C/W
ψ _{JT}	Junction-to-top characterization parameter	42.4	°C/W
ψ _{JB}	Junction-to-board characterization parameter	284.8	°C/W
R _{θJC(bot)}	Junction-to-case (bottom) thermal resistance	142.3	°C/W

- (1) For more information about traditional and new thermal metrics, see the [Semiconductor and IC Package Thermal Metrics](#) application report.

7.5 Electrical Characteristics

over the operating junction temperature range of -40°C to $+125^{\circ}\text{C}$ ($T_A = T_J$), $1.5\text{ V} \leq V_{DD} \leq 5.5\text{ V}$, and $\overline{\text{MR}} = V_{DD}$ (unless otherwise noted); typical values are at $V_{DD} = 5.5\text{ V}$ and $T_J = 25^{\circ}\text{C}$

PARAMETER		TEST CONDITIONS	MIN	TYP	MAX	UNIT
V_{DD}	Input supply voltage		1.5		5.5	V
V_{POR}	Power-on-reset voltage	$V_{OL(max)} = 0.2\text{ V}$, $I_{RESET} = 15\ \mu\text{A}$			0.8	V
I_{DD}	Supply current (into VDD pin)	$V_{DD} = 3.3\text{ V}$, $I_{RESET} = 0\text{ mA}$, $-40^{\circ}\text{C} < T_J < 85^{\circ}\text{C}$		2.09	3.72	μA
		$V_{DD} = 3.3\text{ V}$, $I_{RESET} = 0\text{ mA}$, $-40^{\circ}\text{C} < T_J < 105^{\circ}\text{C}$			4.5	
		$V_{DD} = 3.3\text{ V}$, $I_{RESET} = 0\text{ mA}$			5.8	
		$V_{DD} = 5.5\text{ V}$, $I_{RESET} = 0\text{ mA}$, $-40^{\circ}\text{C} < T_J < 85^{\circ}\text{C}$		2.29	4	
		$V_{DD} = 5.5\text{ V}$, $I_{RESET} = 0\text{ mA}$, $-40^{\circ}\text{C} < T_J < 105^{\circ}\text{C}$			5.2	
		$V_{DD} = 5.5\text{ V}$, $I_{RESET} = 0\text{ mA}$			6.5	
V_{ITN} , V_{ITP}	SENSE input threshold voltage accuracy		-1%	$\pm 0.5\%$	1%	
V_{HYST}	Hysteresis ⁽¹⁾		0.325%	0.575%	0.825%	
I_{SENSE}	Input current	$V_{SENSE} = 5\text{ V}$			8	μA
		$V_{SENSE} = 5\text{ V}$, TPS389001-Q1, TPS389012-Q1		10	100	nA
I_{CT}	CT pin charge current		0.90	1.15	1.35	μA
V_{CT}	CT pin comparator threshold voltage		1.17	1.23	1.29	V
R_{CT}	CT pin pulldown resistance	When $\overline{\text{RESET}}$ is deasserted		200		Ω
V_{IL}	Low-level input voltage ($\overline{\text{MR}}$ pin)			$0.25 \times V_{DD}$		V
V_{IH}	High-level output voltage		$0.7 \times V_{DD}$			V
V_{OL}	Low-level output voltage	$V_{DD} \geq 1.5\text{ V}$, $I_{RESET} = 0.4\text{ mA}$			0.25	V
		$V_{DD} \geq 2.7\text{ V}$, $I_{RESET} = 2\text{ mA}$			0.25	
		$V_{DD} \geq 4.5\text{ V}$, $I_{RESET} = 3\text{ mA}$			0.3	
$I_{LKG(OD)}$	Open-drain output leakage	High impedance, $V_{SENSE} = V_{RESET} = 5.5\text{ V}$			250	nA

(1) $V_{HYST} = [(V_{ITP} - V_{ITN}) / V_{ITN}] \times 100\%$.

7.6 Timing Requirements

over the operating junction temperature range of -40°C to $+125^{\circ}\text{C}$ ($T_A = T_J$), $1.5\text{ V} \leq V_{DD} \leq 5.5\text{ V}$, $\overline{\text{MR}} = V_{DD}$, and 5% input overdrive⁽¹⁾ (unless otherwise noted); typical values are at $V_{DD} = 5.5\text{ V}$ and $T_J = 25^{\circ}\text{C}$

		MIN	NOM	MAX	UNIT
$t_{PD(f)}$	SENSE (falling) to $\overline{\text{RESET}}$ propagation delay	$C_T = \text{open}$, $V_{DD} = 3.3\text{ V}$	18		μs
		$C_T = \text{open}$, $V_{DD} = 5.5\text{ V}$	8		
$t_{PD(r)}$	SENSE (rising) to $\overline{\text{RESET}}$ propagation delay	$C_T = \text{open}$, $V_{DD} = 3.3\text{ V}$	25		μs
$t_{GI(SENSE)}$	SENSE pin glitch immunity	$V_{DD} = 5.5\text{ V}$	9		μs
$t_{GI(MR)}$	$\overline{\text{MR}}$ pin glitch immunity	$V_{DD} = 5.5\text{ V}$	100		ns
t_{MRW}	$\overline{\text{MR}}$ pin pulse duration to assert $\overline{\text{RESET}}$	1			μs
$t_{d(MR)}$	$\overline{\text{MR}}$ pin low to out delay		250		ns
t_{STRT}	Startup delay		325		μs

(1) Overdrive = $| (V_{IN} / V_{THRESH} - 1) \times 100\% |$.



图 1. Timing Diagram

7.7 Typical Characteristics

over the operating junction temperature range of -40°C to $+125^{\circ}\text{C}$, $1.5\text{ V} \leq V_{\text{DD}} \leq 5.5\text{ V}$, and $\overline{\text{MR}} = V_{\text{DD}}$ (unless otherwise noted)

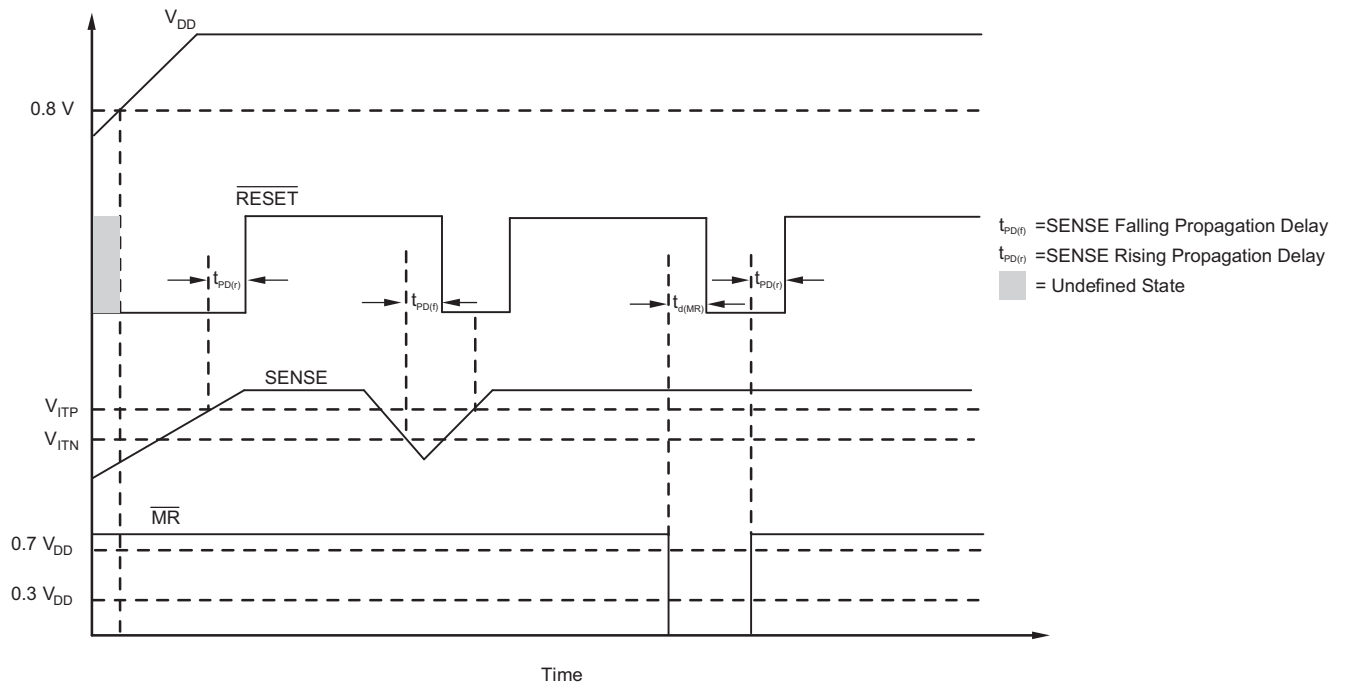

图 2. V_{ITN} Accuracy vs Temperature



图 3. V_{ITP} Accuracy vs Temperature

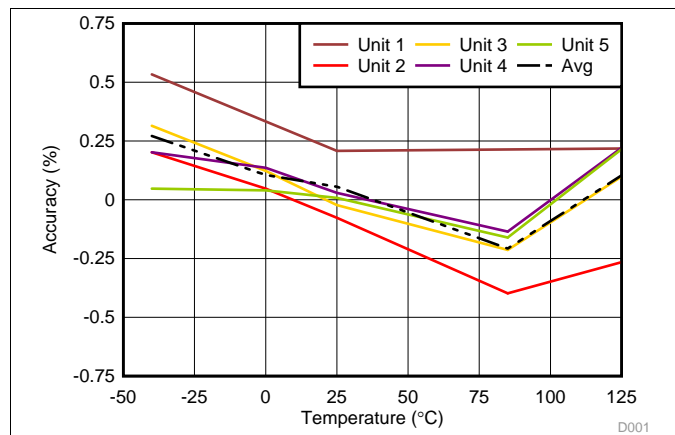

图 4. V_{ITN} Accuracy Histogram

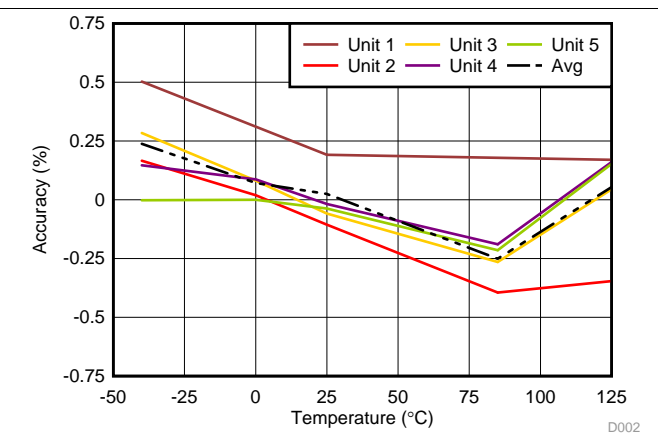

图 5. V_{ITP} Accuracy Histogram

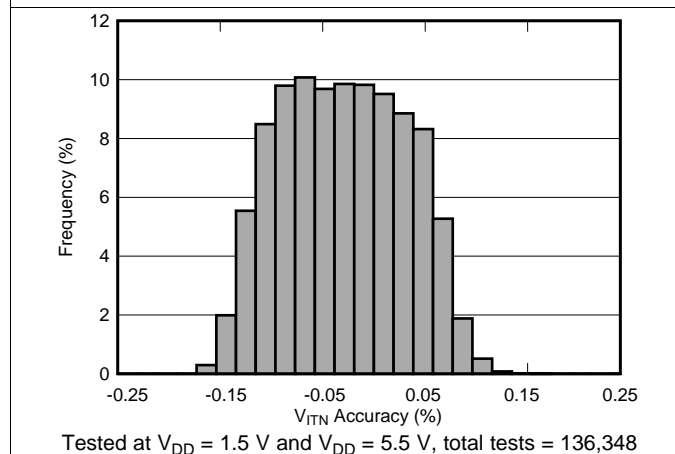

图 6. Hysteresis Histogram

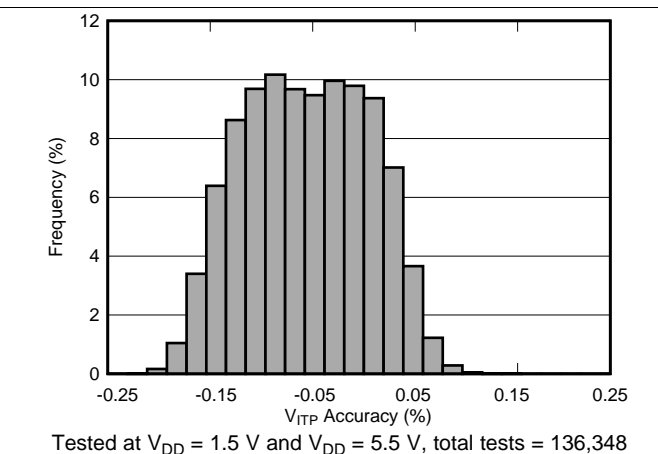

图 7. CT Current vs Temperature

Typical Characteristics (接下页)

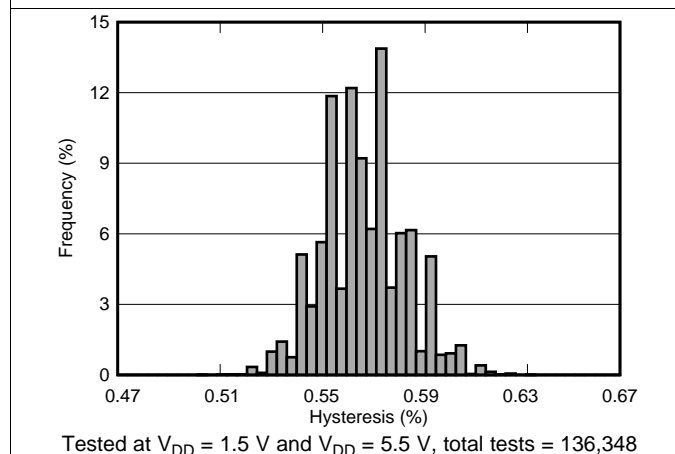
over the operating junction temperature range of -40°C to $+125^{\circ}\text{C}$, $1.5\text{ V} \leq V_{\text{DD}} \leq 5.5\text{ V}$, and $\overline{\text{MR}} = V_{\text{DD}}$ (unless otherwise noted)

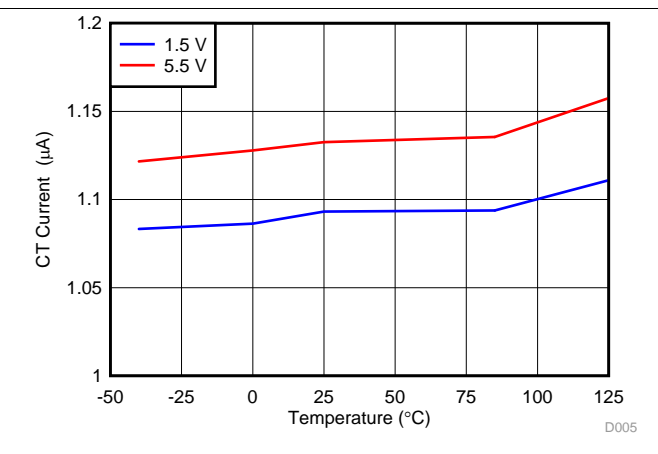

图 8. Supply Current vs Power-Supply Voltage



图 9. Supply Current vs Power-Supply Voltage

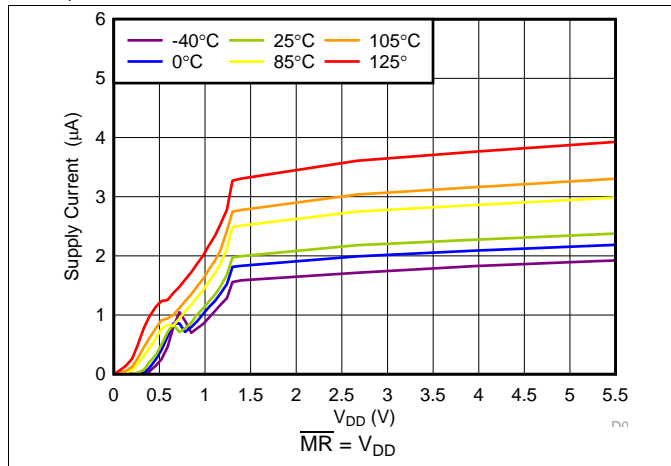

图 10. $\overline{\text{MR}}$ Threshold vs Temperature

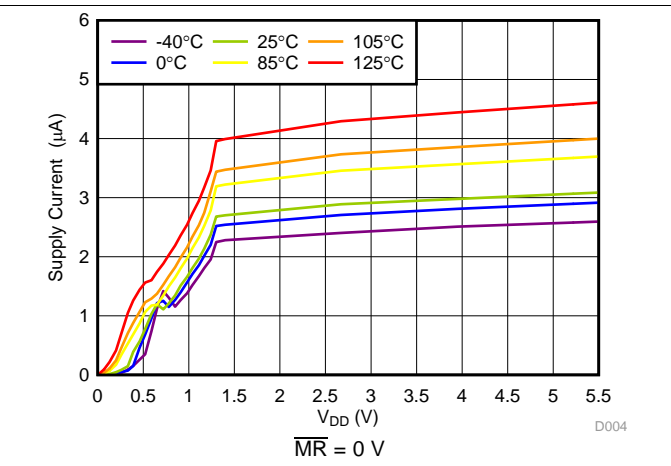

图 11. $\overline{\text{MR}}$ Threshold vs Temperature

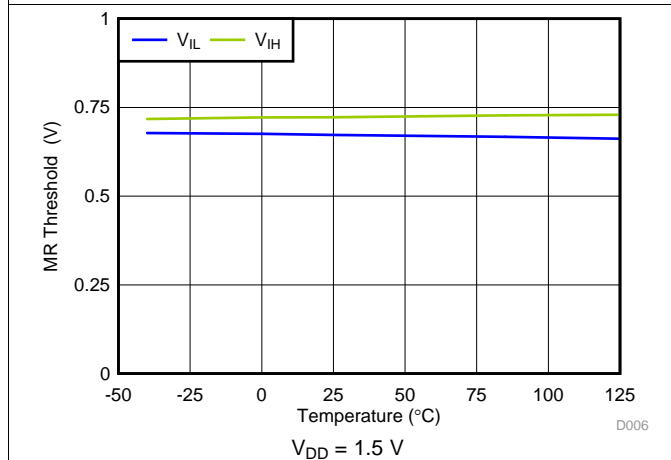

图 12. Startup Delay vs Temperature

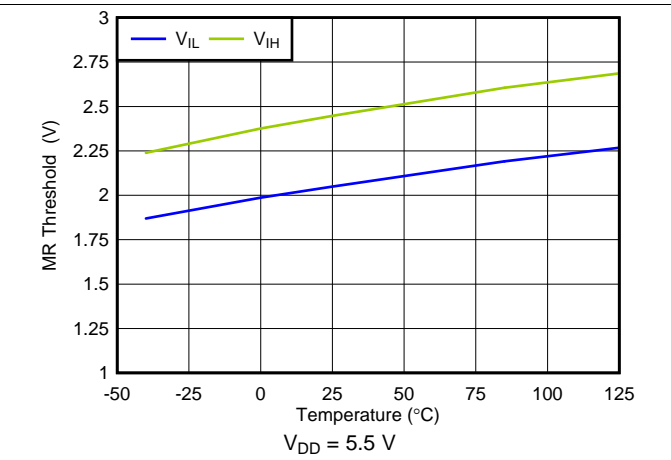

图 13. Propagation Delay ($t_{\text{PD}(r)}$) vs Overdrive

Typical Characteristics (接下页)

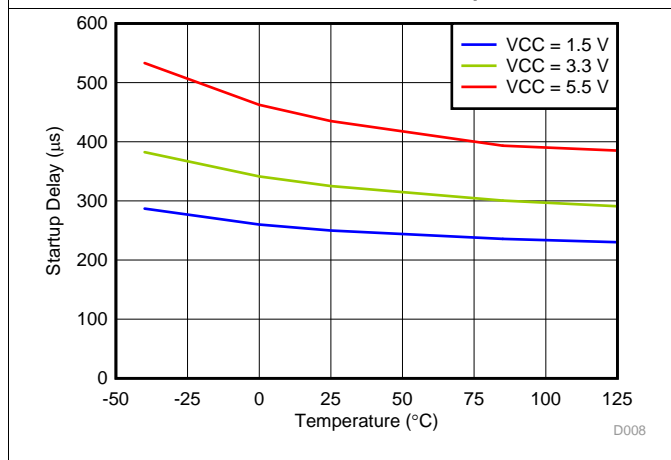
over the operating junction temperature range of -40°C to $+125^{\circ}\text{C}$, $1.5\text{ V} \leq V_{\text{DD}} \leq 5.5\text{ V}$, and $\overline{\text{MR}} = V_{\text{DD}}$ (unless otherwise noted)

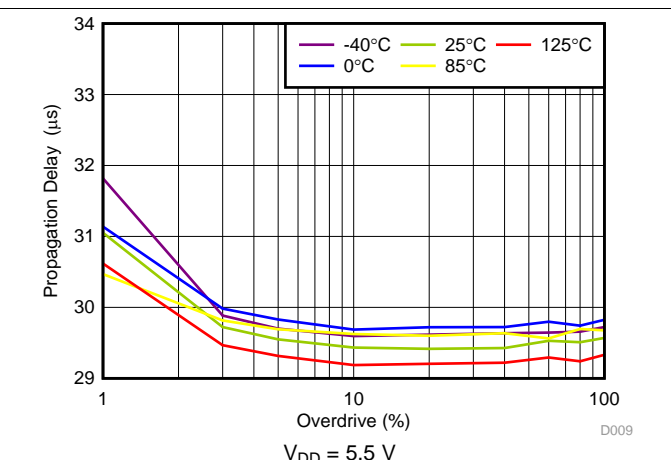

图 14. Propagation Delay ($t_{\text{PD}(f)}$) vs Overdrive



图 15. Propagation Delay ($t_{\text{PD}(f)}$) vs Overdrive

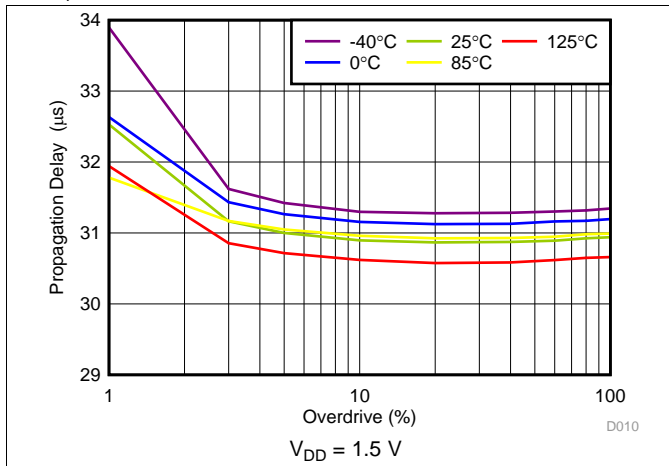

图 16. Propagation Delay ($t_{\text{PD}(f)}$) vs Overdrive

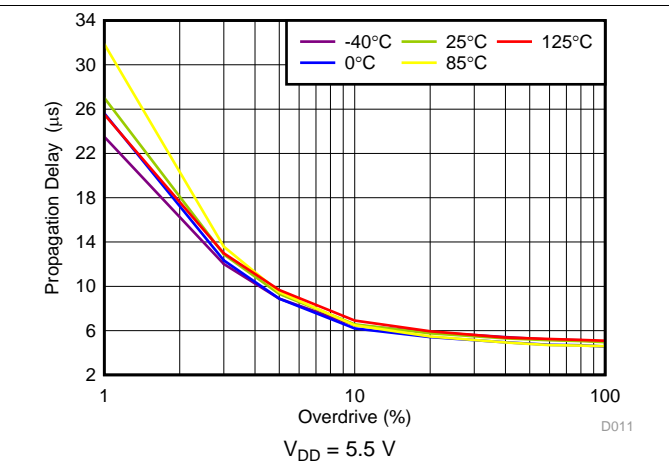

图 17. Low-to-High Glitch Immunity vs Temperature

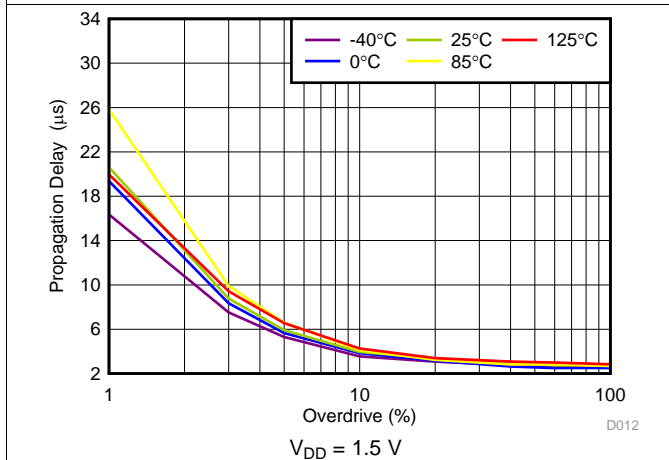

图 18. Low-to-High Glitch Immunity vs Temperature

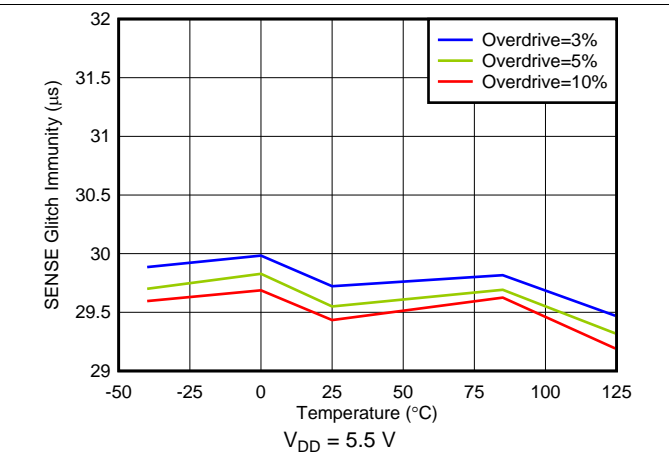

图 19. High-to-Low Glitch Immunity vs Temperature

Typical Characteristics (接下页)

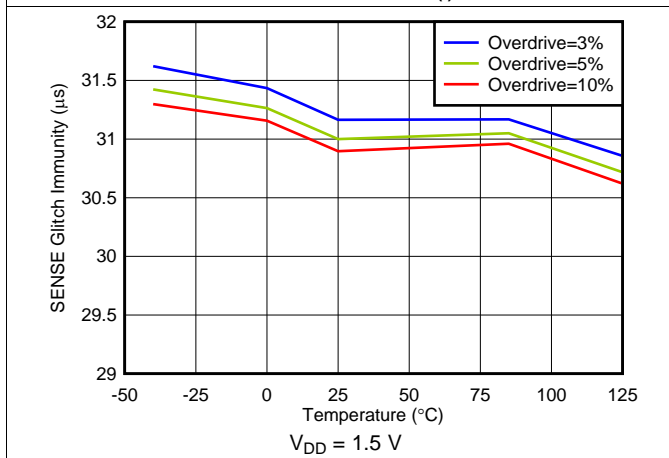
over the operating junction temperature range of -40°C to $+125^{\circ}\text{C}$, $1.5\text{ V} \leq V_{\text{DD}} \leq 5.5\text{ V}$, and $\overline{\text{MR}} = V_{\text{DD}}$ (unless otherwise noted)

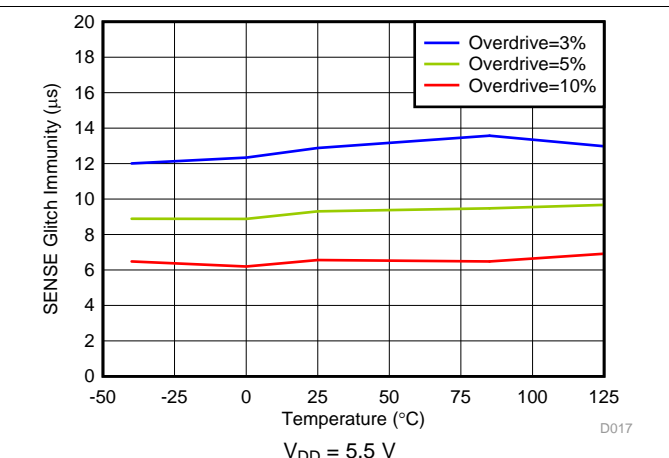

图 20. High-to-Low Glitch Immunity vs Temperature

图 21. Low-Level Output Voltage vs RESET Current

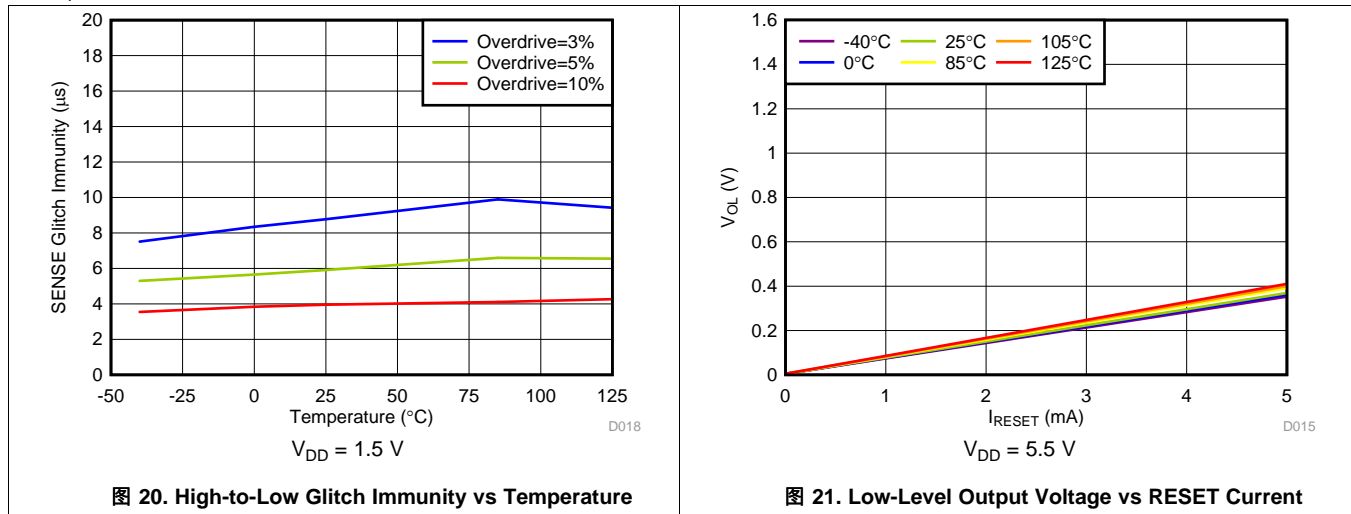

图 22. Low-Level Output Voltage vs RESET Current

8 Detailed Description

8.1 Overview

The TPS3890-Q1 supervisory product family is designed to assert a $\overline{\text{RESET}}$ signal when either the SENSE pin voltage drops below V_{ITN} or the manual reset ($\overline{\text{MR}}$) is driven low. The $\overline{\text{RESET}}$ output remains asserted for a user-adjustable time after both the manual reset ($\overline{\text{MR}}$) and SENSE voltages return above their respective thresholds.

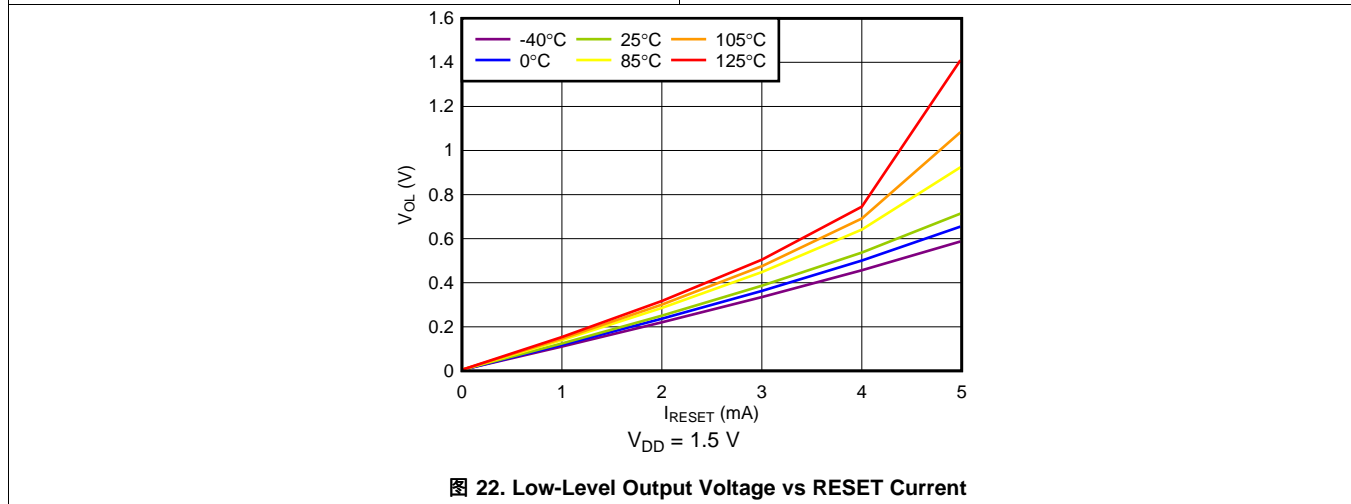
8.2 Functional Block Diagram

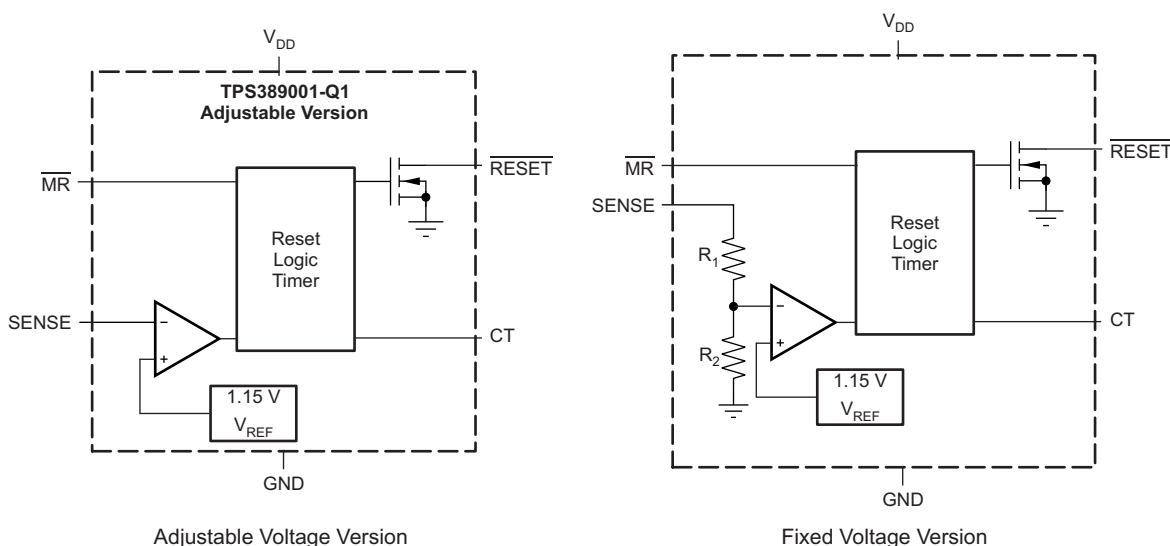

Copyright © 2016, Texas Instruments Incorporated

8.3 Feature Description

The combination of user-adjustable reset delay time with a broad range of threshold voltages allow these devices to be used in a wide array of applications. Fixed negative threshold voltages (V_{ITN}) can be factory set from 1.15 V to 3.17 V (see the [Device Comparison Table](#) for available options), and the adjustable device can be used to customize the threshold voltage for other application needs by using an external resistor divider. The CT pin allows the reset delay to be set between 25 μs and 30 s with the use of an external capacitor.

8.3.1 User-Configurable $\overline{\text{RESET}}$ Delay Time

The rising $\overline{\text{RESET}}$ delay time ($t_{\text{PD}(r)}$) can be configured by installing a capacitor connected to the CT pin. The TPS3890-Q1 uses a CT pin charging current (I_{CT}) of 1.15 μA to help counter the effect of capacitor and board-level leakage currents that can be substantial in certain applications. The rising $\overline{\text{RESET}}$ delay time can be set to any value between 25 μs (no C_{CT} installed) and 30 s ($C_{\text{CT}} = 26 \mu\text{F}$).

The capacitor value needed for a given delay time can be calculated using [公式 1](#):

$$t_{\text{PD}(r)} (\text{SEC}) = C_{\text{CT}} \times V_{\text{CT}} \div I_{\text{CT}} + t_{\text{PD}(r)(\text{nom})} \quad (1)$$

The slope of [公式 1](#) is determined by the time that the CT charging current (I_{CT}) takes to charge the external capacitor up to the CT comparator threshold voltage (V_{CT}). When $\overline{\text{RESET}}$ is asserted, the capacitor is discharged through the internal CT pulldown resistor (R_{CT}). When the $\overline{\text{RESET}}$ conditions are cleared, the internal precision current source is enabled and begins to charge the external capacitor and when the voltage on this capacitor reaches 1.22 V, $\overline{\text{RESET}}$ is deasserted. Note that in order to minimize the difference between the calculated $\overline{\text{RESET}}$ delay time and the actual $\overline{\text{RESET}}$ delay time, use a low-leakage type capacitor (such as a ceramic capacitor) and minimize parasitic board capacitance around this pin.

Feature Description (接下页)

8.3.2 Manual Reset ($\overline{\text{MR}}$) Input

The manual reset ($\overline{\text{MR}}$) input allows a processor or other logic circuits to initiate a reset. A logic low on $\overline{\text{MR}}$ causes $\overline{\text{RESET}}$ to assert. After $\overline{\text{MR}}$ returns to a logic high and SENSE is above V_{ITP} , $\overline{\text{RESET}}$ is deasserted after the user-defined reset delay. If $\overline{\text{MR}}$ is not controlled externally, then $\overline{\text{MR}}$ must be connected to V_{DD} . Note that if the logic signal driving $\overline{\text{MR}}$ is not greater than or equal to V_{DD} , then some additional current flows into V_{DD} and out of $\overline{\text{MR}}$ and the difference is apparent when comparing 图 8 and 图 9.

图 23 shows how $\overline{\text{MR}}$ can be used to monitor multiple system voltages when only a single CT capacitor is needed to set the $\overline{\text{RESET}}$ delay time.



图 23. Using $\overline{\text{MR}}$ to Monitor Multiple System Voltages

8.3.3 $\overline{\text{RESET}}$ Output

$\overline{\text{RESET}}$ remains high (deasserted) as long as SENSE is above the positive threshold (V_{ITP}) and the manual reset signal ($\overline{\text{MR}}$) is logic high. If SENSE falls below the negative threshold (V_{ITN}) or if $\overline{\text{MR}}$ is driven low, then $\overline{\text{RESET}}$ is asserted, driving the $\overline{\text{RESET}}$ pin to a low impedance.

When $\overline{\text{MR}}$ is again logic high and SENSE is above V_{ITP} , a delay circuit is enabled that holds $\overline{\text{RESET}}$ low for a specified reset delay period ($t_{\text{PD}(r)}$). When the reset delay has elapsed, the $\overline{\text{RESET}}$ pin goes to a high-impedance state and uses a pullup resistor to hold $\overline{\text{RESET}}$ high. Connect the pullup resistor to the proper voltage rail to enable the outputs to be connected to other devices at the correct interface voltage level. $\overline{\text{RESET}}$ can be pulled up to any voltage up to 5.5 V, independent of the device supply voltage. To ensure proper voltage levels, give some consideration when choosing the pullup resistor values. The pullup resistor value is determined by V_{OL} , the output capacitive loading, and the output leakage current ($I_{\text{LKG(OD)}}$).

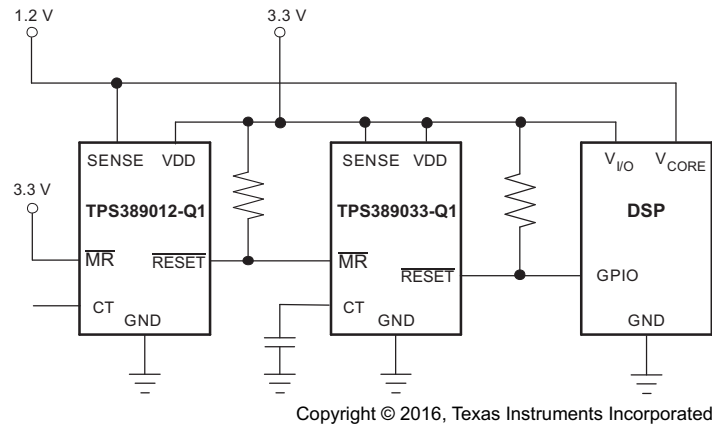
8.3.4 SENSE Input

The SENSE input can vary from ground to 5.5 V (7.0 V, absolute maximum), regardless of the device supply voltage used. The SENSE pin is used to monitor the critical voltage rail. If the voltage on this pin drops below V_{ITN} , then $\overline{\text{RESET}}$ is asserted. When the voltage on the SENSE pin exceeds the positive threshold voltage, $\overline{\text{RESET}}$ deasserts after the user-defined $\overline{\text{RESET}}$ delay time.

The internal comparator has built-in hysteresis to ensure well-defined $\overline{\text{RESET}}$ assertions and deassertions even when there are small changes on the voltage rail being monitored.

The TPS3890-Q1 device is relatively immune to short transients on the SENSE pin. Glitch immunity is dependent on threshold overdrive, as illustrated in 图 19 for V_{ITN} and 图 18 for V_{ITP} . Although not required in most cases, for noisy applications good analog design practice is to place a 1-nF to 10-nF bypass capacitor at the SENSE input to reduce sensitivity to transient voltages on the monitored signal.

Feature Description (接下页)

The adjustable version (TPS389001-Q1) can be used to monitor any voltage rail down to 1.15 V using the circuit shown in 图 24.



图 24. Using the TPS389001-Q1 to Monitor a User-Defined Threshold Voltage

The target threshold voltage for the monitored supply ($V_{ITx(MON)}$) and the resistor divider values can be calculated by using 公式 2 and 公式 3, respectively:

$$V_{ITx(MON)} = V_{ITx} \times (1 + R_1 \div R_2) \quad (2)$$

公式 3 can be used to calculate either the negative threshold or the positive threshold by replacing V_{ITx} with either V_{ITN} or V_{ITP} , respectively.

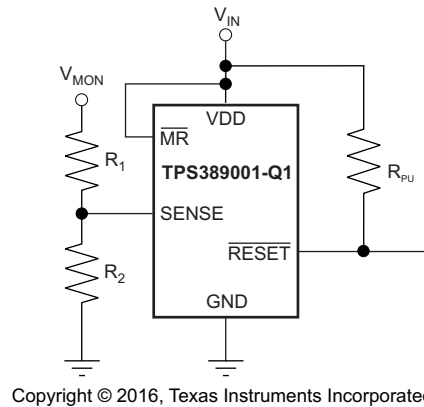
$$R_{TOTAL} = R_1 + R_2 \quad (3)$$

Resistors with high values minimize current consumption; however, the input bias current of the device degrades accuracy if the current through the resistors is too low. Therefore, choosing an R_{TOTAL} value so that the current through the resistor divider is at least 100 times larger than the SENSE input current is simplest. See the [Optimizing Resistor Dividers at a Comparator Input](#) application report for more details on sizing input resistors.

8.3.4.1 Immunity to SENSE Pin Voltage Transients

The TPS3890-Q1 is immune to short voltage transient spikes on the input pins. Sensitivity to transients depends on both transient duration and overdrive (amplitude) of the transient. Overdrive is defined by how much V_{SENSE} exceeds the specified threshold, and is important to know because the smaller the overdrive, the slower the response of the outputs (that is, undervoltage and overvoltage). Threshold overdrive is calculated as a percent of the threshold in question, as shown in 公式 4.

$$\text{Overdrive} = | (V_{SENSE} / V_{ITx} - 1) \times 100\% | \quad (4)$$

图 17 to 图 20 illustrate the glitch immunity that the TPS3890-Q1 has versus temperature with three different overdrive voltages. The propagation delay versus overdrive curves (图 13 to 图 16) can be used to determine how sensitive the TPS3890-Q1 family of devices are across an even wider range of overdrive voltages.

8.4 Device Functional Modes

表 1 summarizes the various functional modes of the device.

表 1. Truth Table

V_{DD}	\overline{MR}	SENSE	\overline{RESET}
$V_{DD} < V_{POR}$	—	—	Undefined
$V_{POR} < V_{DD} < V_{DD(MIN)}^{(1)}$	—	—	L
$V_{DD} \geq V_{DD(MIN)}$	L	—	L
$V_{DD} \geq V_{DD(MIN)}$	H	$V_{SENSE} < V_{ITN}$	L
$V_{DD} \geq V_{DD(MIN)}$	H	$V_{SENSE} > V_{ITP}$	H

(1) When V_{DD} falls below $V_{DD(MIN)}$, undervoltage-lockout (UVLO) takes effect and \overline{RESET} is held low until V_{DD} falls below V_{POR} .

8.4.1 Normal Operation ($V_{DD} > V_{DD(min)}$)

When V_{DD} is greater than $V_{DD(min)}$, the \overline{RESET} signal is determined by the voltage on the SENSE pin and the logic state of \overline{MR} .

- \overline{MR} high: when the voltage on V_{DD} is greater than 1.5 V, the \overline{RESET} signal corresponds to the voltage on the SENSE pin relative to the threshold voltage.
- \overline{MR} low: in this mode, \overline{RESET} is held low regardless of the voltage on the SENSE pin.

8.4.2 Above Power-On-Reset But Less Than $V_{DD(min)}$ ($V_{POR} < V_{DD} < V_{DD(min)}$)

When the voltage on V_{DD} is less than the $V_{DD(min)}$ voltage, and greater than the power-on-reset voltage (V_{POR}), the \overline{RESET} signal is asserted regardless of the voltage on the SENSE pin.

8.4.3 Below Power-On-Reset ($V_{DD} < V_{POR}$)

When the voltage on V_{DD} is lower than V_{POR} , the device does not have enough voltage to internally pull the asserted output low and \overline{RESET} is undefined and must not be relied upon for proper device function.

9 Application and Implementation

注

Information in the following applications sections is not part of the TI component specification, and TI does not warrant its accuracy or completeness. TI's customers are responsible for determining suitability of components for their purposes. Customers should validate and test their design implementation to confirm system functionality.

9.1 Application Information

The following sections describe in detail how to properly use this device, depending on the requirements of the final application.

9.2 Typical Application

A typical application for the TPS389018-Q1 is shown in 图 25. The TPS389018-Q1 can be used to monitor the 1.8-V VDD rail required by the TI Delfino™ microprocessor family. The open-drain RESET output of the TPS389018-Q1 is connected to the XRS input of the microprocessor. A reset event is initiated when the VDD voltage is less than V_{ITN} or when MR is driven low by an external source.



图 25. TPS3890-Q1 Monitoring the Supply Voltage for a Delfino Microprocessor

9.2.1 Design Requirements

The TPS3890-Q1 RESET output can be used to drive the reset (XRS) input of a microprocessor. The RESET pin of the TPS3890-Q1 is pulled high with a 1-MΩ resistor; the reset delay time is controlled by the CT capacitor and is set depending on the reset requirement times of the microprocessor. During power-up, XRS must remain low for at least 1 ms after VDD reaches 1.5 V for the C2000™ Delfino family of microprocessors. For 100-MHz operation, the Delfino TMS320F2833x microcontroller uses a supply voltage of 1.8 V that must be monitored by the TPS3890-Q1.

9.2.2 Detailed Design Procedure

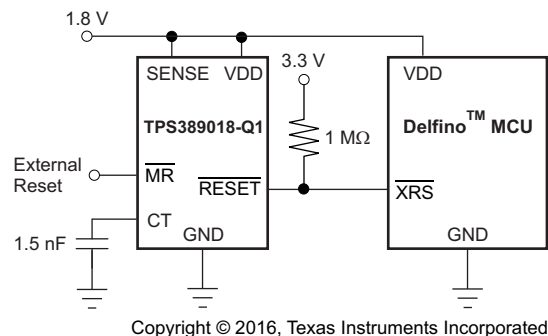
The primary constraint for this application is choosing the correct device to monitor the supply voltage of the microprocessor. The TPS389018-Q1 has a negative threshold of 1.73 V and a positive threshold of 1.74 V, making the device suitable for monitoring a 1.8-V rail. The secondary constraint for this application is the reset delay time that must be at least 1 ms to allow the Delfino microprocessor enough time to startup up correctly. Because a minimum time is required, the worst-case scenario is a supervisor with a high CT charging current (I_{CT}) and a low CT comparator threshold (V_{CT}). For applications with ambient temperatures ranging from -40°C to $+125^{\circ}\text{C}$, C_{CT} can be calculated using $I_{CT(\text{Max})}$, $V_{CT(\text{MIN})}$, and solving for C_{CT} in 公式 1 such that the minimum capacitance required at the CT pin is 1.149 nF. If standard capacitors with $\pm 20\%$ tolerances are used, then the CT capacitor must be 1.5 nF or larger to ensure that the 1-ms delay time is met.

A 0.1-μF decoupling capacitor is connected to the VDD pin as a good analog design practice and a 1-MΩ resistor is used as the RESET pullup resistor to minimize the current consumption when RESET is asserted. The MR pin can be connected to an external signal if desired or connected to VDD if not used.

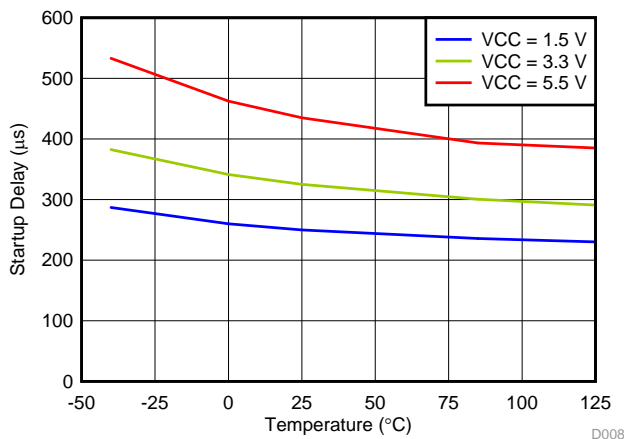
Typical Application (接下页)
9.2.3 Application Curve

图 26. Startup Delay vs Temperature
10 Power Supply Recommendations

These devices are designed to operate from an input supply with a voltage range between 1.5 V and 5.5 V. An input supply capacitor is not required for this device; however, if the input supply is noisy, then good analog practice is to place a 0.1- μ F capacitor between the VDD pin and the GND pin. This device has a 7-V absolute maximum rating on the VDD pin. If the voltage supply providing power to VDD is susceptible to any large voltage transient that can exceed 7 V, additional precautions must be taken.

11 Layout

11.1 Layout Guidelines

Make sure that the connection to the VDD pin is low impedance. Good analog design practice is to place a 0.1- μ F ceramic capacitor near the VDD pin. If a capacitor is not connected to the CT pin, then minimize parasitic capacitance on this pin so the $\overline{\text{RESET}}$ delay time is not adversely affected.

11.2 Layout Example

The layout example in shows how the TPS3890-Q1 is laid out on a printed circuit board (PCB) with a user-defined delay.

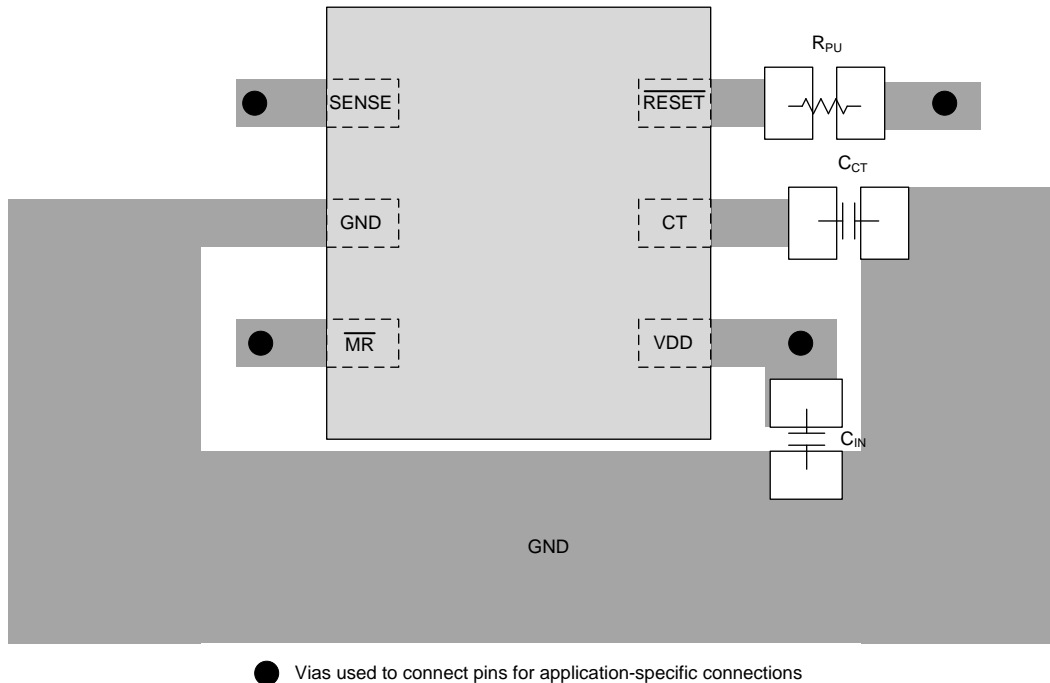

● Vias used to connect pins for application-specific connections

图 27. Recommended Layout

12 器件和文档支持

12.1 器件支持

12.1.1 器件命名规则

表 2 以 TPS389033G-Q1 为例，介绍了如何根据器件编号来解译器件的功能。

表 2. 器件命名约定

说明	命名规则	值
TPS3890 (高精度监控器系列)	—	—
33 (拟监控的标称轨电压)	10	1.0V
	12	1.2V
	18	1.8V
	33	3.3V
	50	5.0V
G (V_{ITN} 低于标称轨电压的百分比)	—	4%
	G	7%
	K	11%
	L	12%
Q1 (汽车版本)	—	—

12.2 文档支持

12.2.1 相关文档

如需相关文档，请参阅：

- [《优化比较器输入上的电阻分压器》](#)
- [《电源设计灵敏度分析》](#)
- [《TMS320C28x 数字信号控制器入门》](#)
- [《TPS3890EVM-775 评估模块用户指南》](#)
- [C2000 Delfino 系列微处理器](#)
- [《TMS320F2833x 数字信号控制器 \(DSC\)》](#)

12.3 接收文档更新通知

要接收文档更新通知，请导航至 TI.com.cn 上的器件产品文件夹。请单击右上角的提醒我进行注册，即可每周接收产品信息更改摘要。有关更改的详细信息，请查看任何已修订文档中包含的修订历史记录。

12.4 社区资源

下列链接提供到 TI 社区资源的连接。链接的内容由各个分销商“按照原样”提供。这些内容并不构成 TI 技术规范，并且不一定反映 TI 的观点；请参阅 TI 的 [《使用条款》](#)。

TI E2E™ 在线社区 *TI 的工程师对工程师 (E2E) 社区*。此社区的创建目的在于促进工程师之间的协作。在 e2e.ti.com 中，您可以咨询问题、分享知识、拓展思路并与同行工程师一道帮助解决问题。

设计支持 *TI 参考设计支持* 可帮助您快速查找有帮助的 E2E 论坛、设计支持工具以及技术支持的联系信息。

12.5 商标

Delfino, C2000, E2E are trademarks of Texas Instruments.
All other trademarks are the property of their respective owners.

12.6 静电放电警告



ESD 可能会损坏该集成电路。德州仪器 (TI) 建议通过适当的预防措施处理所有集成电路。如果不遵守正确的处理措施和安装程序，可能会损坏集成电路。

ESD 的损坏小至导致微小的性能降级，大至整个器件故障。精密的集成电路可能更容易受到损坏，这是因为非常细微的参数更改都可能会导致器件与其发布的规格不相符。

12.7 Glossary

[SLYZ022](#) — *TI Glossary*.

This glossary lists and explains terms, acronyms, and definitions.

13 机械、封装和可订购信息

以下页面包含机械、封装和可订购信息。这些信息是指定器件的最新可用数据。数据如有变更，恕不另行通知，也不会对此文档进行修订。如欲获取此数据表的浏览器版本，请参阅左侧的导航。

PACKAGING INFORMATION

Orderable Device	Status (1)	Package Type	Package Drawing	Pins	Package Qty	Eco Plan (2)	Lead finish/ Ball material (6)	MSL Peak Temp (3)	Op Temp (°C)	Device Marking (4/5)	Samples
TPS389001QDSERQ1	ACTIVE	WSON	DSE	6	3000	RoHS & Green	NIPDAUAG	Level-1-260C-UNLIM	-40 to 125	2N	Samples
TPS389012QDSERQ1	ACTIVE	WSON	DSE	6	3000	RoHS & Green	NIPDAUAG	Level-1-260C-UNLIM	-40 to 125	2O	Samples
TPS389015QDSERQ1	ACTIVE	WSON	DSE	6	3000	RoHS & Green	NIPDAUAG	Level-1-260C-UNLIM	-40 to 125	2P	Samples
TPS389018QDSERQ1	ACTIVE	WSON	DSE	6	3000	RoHS & Green	NIPDAUAG	Level-1-260C-UNLIM	-40 to 125	2Q	Samples
TPS389025QDSERQ1	ACTIVE	WSON	DSE	6	3000	RoHS & Green	NIPDAUAG	Level-1-260C-UNLIM	-40 to 125	2R	Samples
TPS389030QDSERQ1	ACTIVE	WSON	DSE	6	3000	RoHS & Green	NIPDAUAG	Level-1-260C-UNLIM	-40 to 125	2S	Samples
TPS389033GQDSERQ1	ACTIVE	WSON	DSE	6	3000	RoHS & Green	NIPDAUAG	Level-1-260C-UNLIM	-40 to 125	7V	Samples
TPS389033KQDSERQ1	ACTIVE	WSON	DSE	6	3000	RoHS & Green	NIPDAUAG	Level-1-260C-UNLIM	-40 to 125	7W	Samples
TPS389033QDSERQ1	ACTIVE	WSON	DSE	6	3000	RoHS & Green	NIPDAUAG	Level-1-260C-UNLIM	-40 to 125	2T	Samples
TPS389050GQDSERQ1	ACTIVE	WSON	DSE	6	3000	RoHS & Green	NIPDAUAG	Level-1-260C-UNLIM	-40 to 125	7T	Samples
TPS389050LQDSERQ1	ACTIVE	WSON	DSE	6	3000	RoHS & Green	NIPDAUAG	Level-1-260C-UNLIM	-40 to 125	7U	Samples
TPS389050QDSERQ1	ACTIVE	WSON	DSE	6	3000	RoHS & Green	NIPDAUAG	Level-1-260C-UNLIM	-40 to 125	7S	Samples

(1) The marketing status values are defined as follows:

ACTIVE: Product device recommended for new designs.

LIFEBUY: TI has announced that the device will be discontinued, and a lifetime-buy period is in effect.

NRND: Not recommended for new designs. Device is in production to support existing customers, but TI does not recommend using this part in a new design.

PREVIEW: Device has been announced but is not in production. Samples may or may not be available.

OBSOLETE: TI has discontinued the production of the device.

(2) **RoHS:** TI defines "RoHS" to mean semiconductor products that are compliant with the current EU RoHS requirements for all 10 RoHS substances, including the requirement that RoHS substance do not exceed 0.1% by weight in homogeneous materials. Where designed to be soldered at high temperatures, "RoHS" products are suitable for use in specified lead-free processes. TI may reference these types of products as "Pb-Free".

RoHS Exempt: TI defines "RoHS Exempt" to mean products that contain lead but are compliant with EU RoHS pursuant to a specific EU RoHS exemption.

Green: TI defines "Green" to mean the content of Chlorine (Cl) and Bromine (Br) based flame retardants meet JS709B low halogen requirements of <=1000ppm threshold. Antimony trioxide based flame retardants must also meet the <=1000ppm threshold requirement.

- (3) MSL, Peak Temp. - The Moisture Sensitivity Level rating according to the JEDEC industry standard classifications, and peak solder temperature.
- (4) There may be additional marking, which relates to the logo, the lot trace code information, or the environmental category on the device.
- (5) Multiple Device Markings will be inside parentheses. Only one Device Marking contained in parentheses and separated by a "~" will appear on a device. If a line is indented then it is a continuation of the previous line and the two combined represent the entire Device Marking for that device.
- (6) Lead finish/Ball material - Orderable Devices may have multiple material finish options. Finish options are separated by a vertical ruled line. Lead finish/Ball material values may wrap to two lines if the finish value exceeds the maximum column width.

Important Information and Disclaimer:The information provided on this page represents TI's knowledge and belief as of the date that it is provided. TI bases its knowledge and belief on information provided by third parties, and makes no representation or warranty as to the accuracy of such information. Efforts are underway to better integrate information from third parties. TI has taken and continues to take reasonable steps to provide representative and accurate information but may not have conducted destructive testing or chemical analysis on incoming materials and chemicals. TI and TI suppliers consider certain information to be proprietary, and thus CAS numbers and other limited information may not be available for release.

In no event shall TI's liability arising out of such information exceed the total purchase price of the TI part(s) at issue in this document sold by TI to Customer on an annual basis.

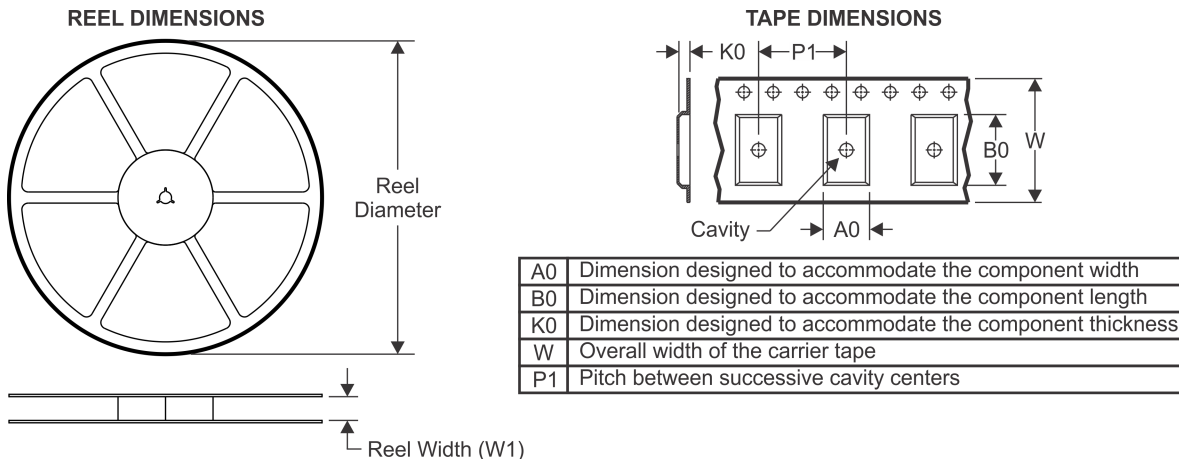
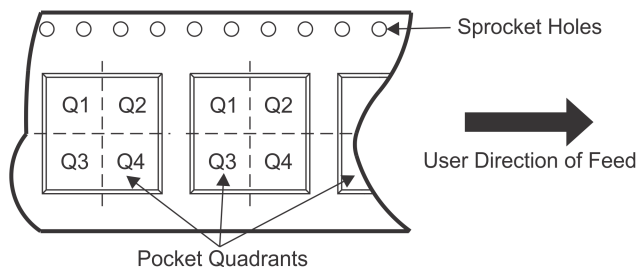
TAPE AND REEL INFORMATION

QUADRANT ASSIGNMENTS FOR PIN 1 ORIENTATION IN TAPE

*All dimensions are nominal

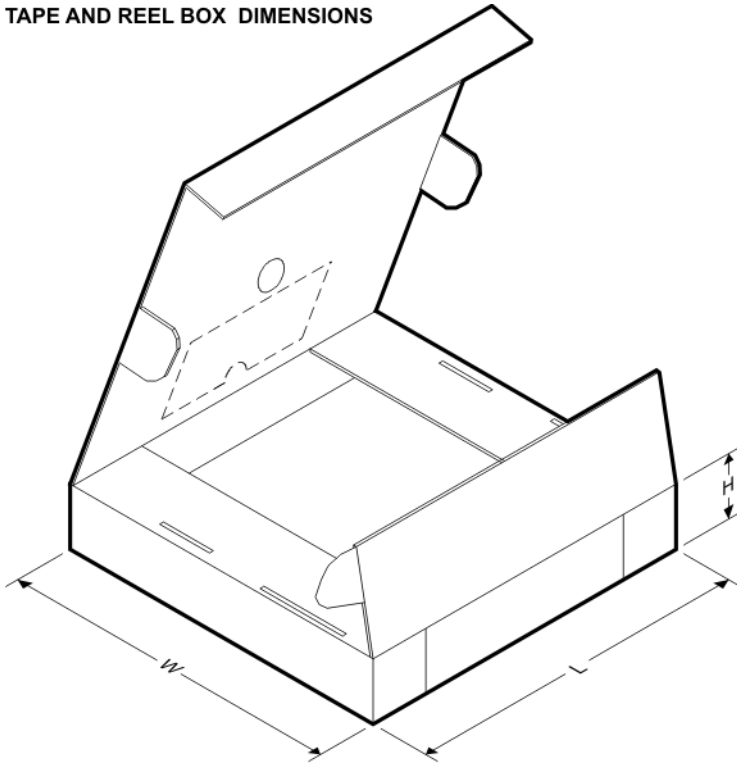
Device	Package Type	Package Drawing	Pins	SPQ	Reel Diameter (mm)	Reel Width W1 (mm)	A0 (mm)	B0 (mm)	K0 (mm)	P1 (mm)	W (mm)	Pin1 Quadrant
TPS389001QDSERQ1	WSON	DSE	6	3000	180.0	8.4	1.83	1.83	0.89	4.0	8.0	Q2
TPS389012QDSERQ1	WSON	DSE	6	3000	180.0	8.4	1.83	1.83	0.89	4.0	8.0	Q2
TPS389015QDSERQ1	WSON	DSE	6	3000	180.0	8.4	1.83	1.83	0.89	4.0	8.0	Q2
TPS389018QDSERQ1	WSON	DSE	6	3000	180.0	8.4	1.83	1.83	0.89	4.0	8.0	Q2
TPS389025QDSERQ1	WSON	DSE	6	3000	180.0	8.4	1.83	1.83	0.89	4.0	8.0	Q2
TPS389030QDSERQ1	WSON	DSE	6	3000	180.0	8.4	1.83	1.83	0.89	4.0	8.0	Q2
TPS389033GQDSERQ1	WSON	DSE	6	3000	180.0	8.4	1.83	1.83	0.89	4.0	8.0	Q2
TPS389033KQDSERQ1	WSON	DSE	6	3000	180.0	8.4	1.83	1.83	0.89	4.0	8.0	Q2
TPS389033QDSERQ1	WSON	DSE	6	3000	180.0	8.4	1.83	1.83	0.89	4.0	8.0	Q2
TPS389050GQDSERQ1	WSON	DSE	6	3000	180.0	8.4	1.83	1.83	0.89	4.0	8.0	Q2
TPS389050LQDSERQ1	WSON	DSE	6	3000	180.0	8.4	1.83	1.83	0.89	4.0	8.0	Q2
TPS389050QDSERQ1	WSON	DSE	6	3000	180.0	8.4	1.83	1.83	0.89	4.0	8.0	Q2

TAPE AND REEL BOX DIMENSIONS

*All dimensions are nominal

Device	Package Type	Package Drawing	Pins	SPQ	Length (mm)	Width (mm)	Height (mm)
TPS389001QDSERQ1	WSON	DSE	6	3000	183.0	183.0	20.0
TPS389012QDSERQ1	WSON	DSE	6	3000	183.0	183.0	20.0
TPS389015QDSERQ1	WSON	DSE	6	3000	183.0	183.0	20.0
TPS389018QDSERQ1	WSON	DSE	6	3000	183.0	183.0	20.0
TPS389025QDSERQ1	WSON	DSE	6	3000	183.0	183.0	20.0
TPS389030QDSERQ1	WSON	DSE	6	3000	183.0	183.0	20.0
TPS389033GQDSERQ1	WSON	DSE	6	3000	183.0	183.0	20.0
TPS389033KQDSERQ1	WSON	DSE	6	3000	183.0	183.0	20.0
TPS389033QDSERQ1	WSON	DSE	6	3000	183.0	183.0	20.0
TPS389050GQDSERQ1	WSON	DSE	6	3000	183.0	183.0	20.0
TPS389050LQDSERQ1	WSON	DSE	6	3000	183.0	183.0	20.0
TPS389050QDSERQ1	WSON	DSE	6	3000	183.0	183.0	20.0

DSE (S-PDSO-N6)

PLASTIC SMALL OUTLINE

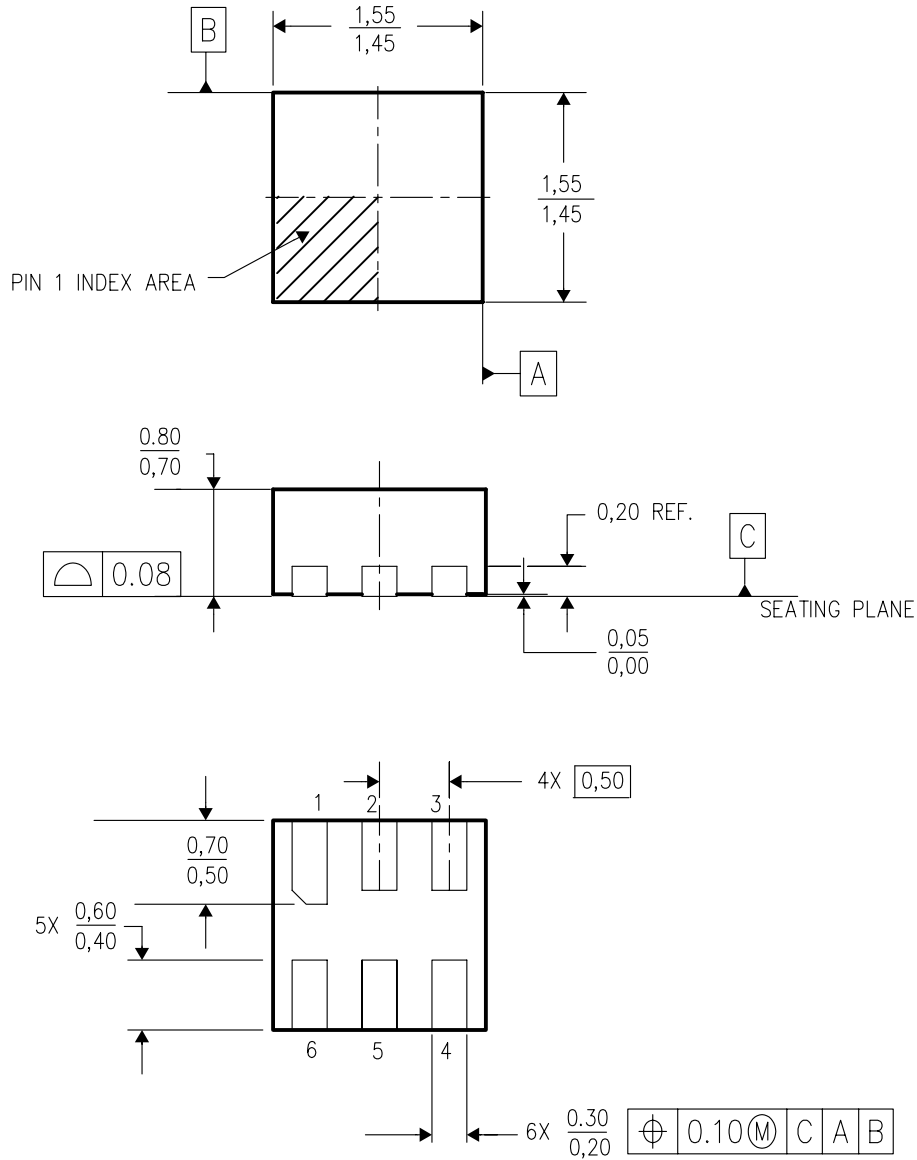

4207810/A 03/06

- NOTES:
- A. All linear dimensions are in millimeters.
 - B. This drawing is subject to change without notice.
 - C. Small Outline No-Lead (SON) package configuration.
 - D. This package is lead-free.

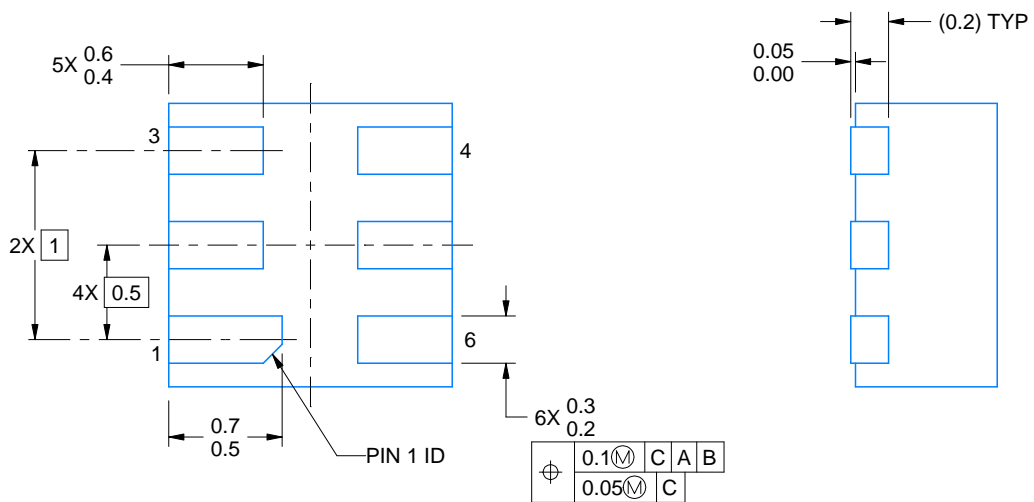
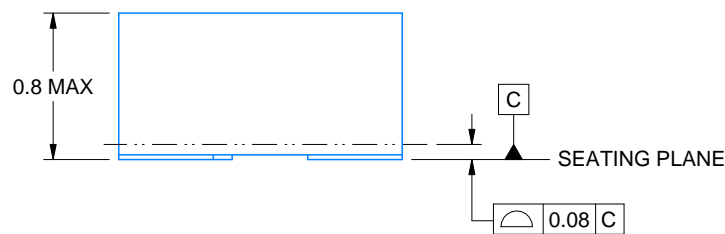
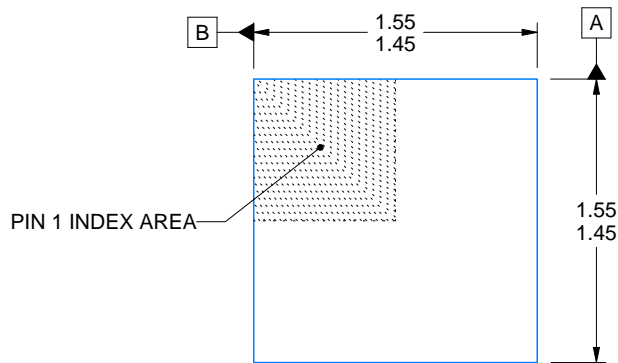

4220552/A 04/2021

NOTES:

1. All linear dimensions are in millimeters. Any dimensions in parenthesis are for reference only. Dimensioning and tolerancing per ASME Y14.5M.
2. This drawing is subject to change without notice.

EXAMPLE BOARD LAYOUT

DSE0006A

WSON - 0.8 mm max height

PLASTIC SMALL OUTLINE - NO LEAD

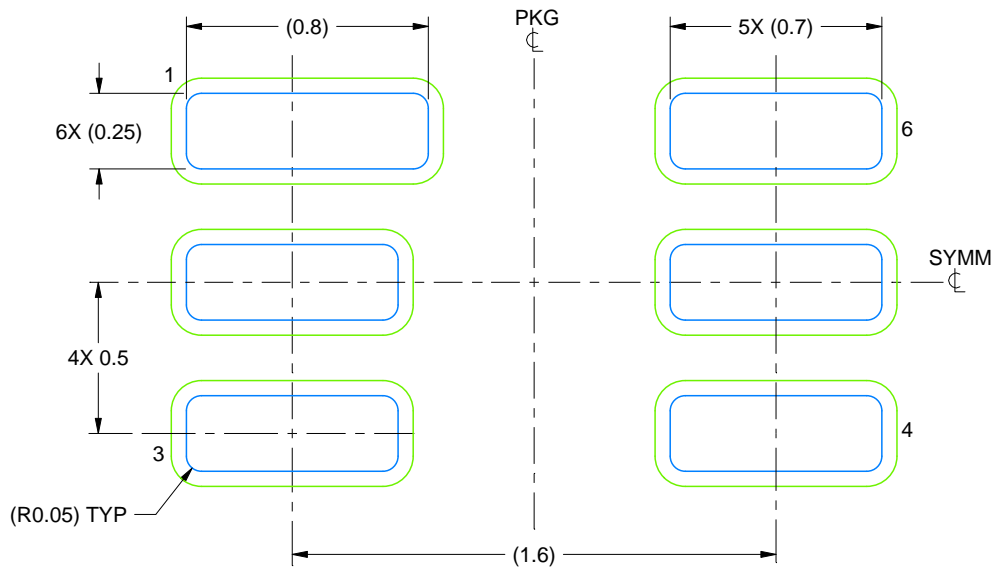

LAND PATTERN EXAMPLE
SCALE:40X

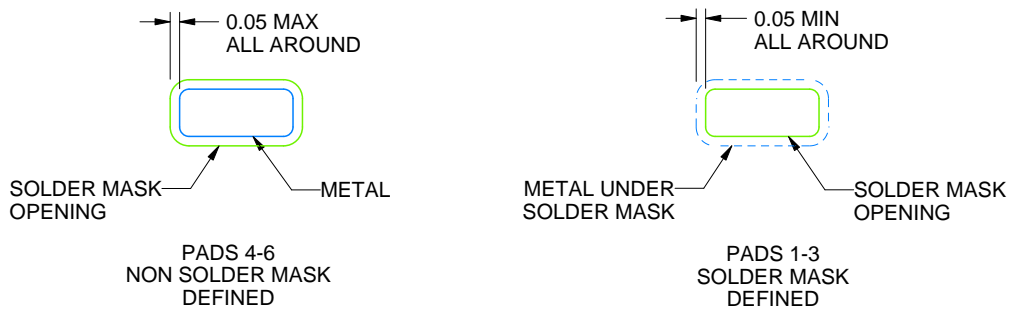

SOLDER MASK DETAILS

4220552/A 04/2021

NOTES: (continued)

3. For more information, see Texas Instruments literature number SLUA271 (www.ti.com/lit/slua271).

EXAMPLE STENCIL DESIGN

DSE0006A

WSON - 0.8 mm max height

PLASTIC SMALL OUTLINE - NO LEAD

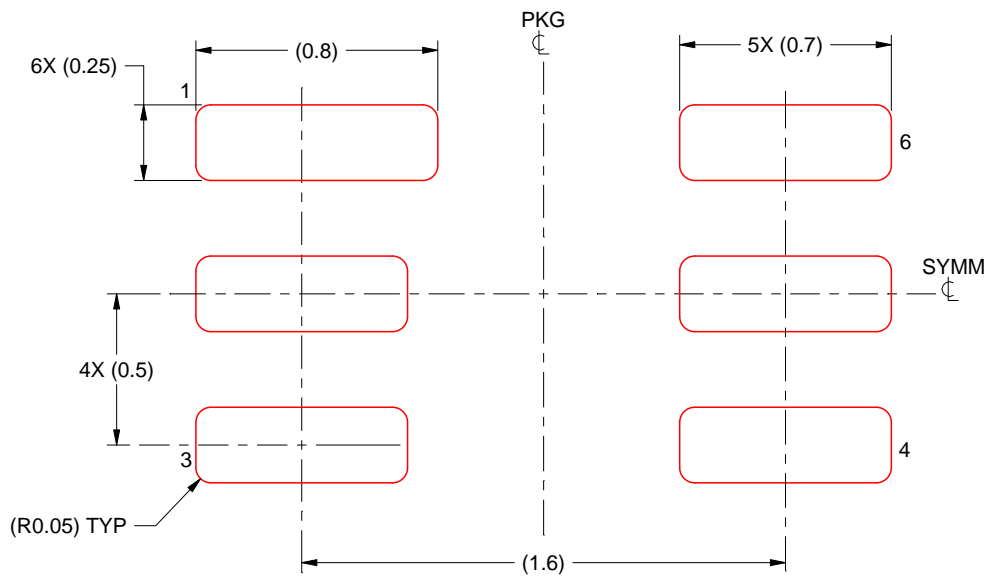

SOLDER PASTE EXAMPLE
BASED ON 0.125 mm THICK STENCIL
SCALE:40X

NOTES: (continued)

4. Laser cutting apertures with trapezoidal walls and rounded corners may offer better paste release. IPC-7525 may have alternate design recommendations.

重要声明和免责声明

TI 提供技术和可靠性数据（包括数据表）、设计资源（包括参考设计）、应用或其他设计建议、网络工具、安全信息和其他资源，不保证没有瑕疵且不做任何明示或暗示的担保，包括但不限于对适销性、某特定用途方面的适用性或不侵犯任何第三方知识产权的暗示担保。

这些资源可供使用 TI 产品进行设计的熟练开发人员使用。您将自行承担以下全部责任：(1) 针对您的应用选择合适的 TI 产品，(2) 设计、验证并测试您的应用，(3) 确保您的应用满足相应标准以及任何其他安全、安保或其他要求。这些资源如有变更，恕不另行通知。TI 授权您仅可将这些资源用于研发本资源所述的 TI 产品的应用。严禁对这些资源进行其他复制或展示。您无权使用任何其他 TI 知识产权或任何第三方知识产权。您应全额赔偿因在这些资源的使用中对 TI 及其代表造成的任何索赔、损害、成本、损失和债务，TI 对此概不负责。

TI 提供的产品受 TI 的销售条款 (<https://www.ti.com.cn/zh-cn/legal/termsofsale.html>) 或 [ti.com.cn](https://www.ti.com.cn) 上其他适用条款/TI 产品随附的其他适用条款的约束。TI 提供这些资源并不会扩展或以其他方式更改 TI 针对 TI 产品发布的适用的担保或担保免责声明。

邮寄地址：上海市浦东新区世纪大道 1568 号中建大厦 32 楼，邮政编码：200122

Copyright © 2021 德州仪器半导体技术（上海）有限公司