

## TPS56221 4.5V 至 14V 输入大电流同步降压转换器

### 1 特性

- 输入电压范围：4.5V 至 14V
- 整合功率块技术
- 输出电流高达 25A
- 固定频率选项：300kHz、500kHz 和 1MHz
- 高侧与低侧 MOSFET  $R_{DS(on)}$  感测
- 可编程软启动
- 600mV 基准电压，精度为 1%
- 前馈电压模式控制
- 支持预偏置输出
- 热关断
- 22 引脚 5mm × 6mm PQFN PowerPAD™ 封装

### 2 应用范围

- 负载点 (POL) 电源模块
- 面向电信和联网应用的高密度 DC-DC 转换器

### 3 说明

TPS56221 器件是一款高效的大电流同步降压转换器，可由 4.5V 至 14V 范围内的电源供电运行。当负载电流高达 25A 时，该器件可产生低至 0.6V 的输出电压。集成的 NexFET™ 功率 MOSFET 尺寸小且易于使用。

该器件可通过电压前馈补偿实施电压模式控制，能够在输入电压变化时立即做出响应。

TPS56221 采用 22 引脚散热增强型 PQFN (DQP) PowerPAD 封装。

该器件支持高度的设计灵活性，可提供各种用户可编程功能，其中包括软启动、过流保护 (OCP) 电平以及环路补偿。OCP 电平可通过 ILIM 引脚与电路接地之间连接的单个外部电阻进行编程。在初始上电排序过程中，该器件会进入校准周期，测量 ILIM 引脚电压，并设置内部 OCP 电压。在工作期间，器件可在通电时通过将可编程 OCP 电压与低侧 FET 两端的压降进行比较来判断是否为过流状况。之后，器件会进入关断 / 重启周期，直到故障消除为止。

#### 器件信息<sup>(1)</sup>

器件型号	封装	封装尺寸 (标称值)
TPS56221	LSON-CLIP (22)	6.00mm × 5.00mm

(1) 如需了解所有可用封装，请见数据表末尾的可订购产品附录。

简化应用电路原理图

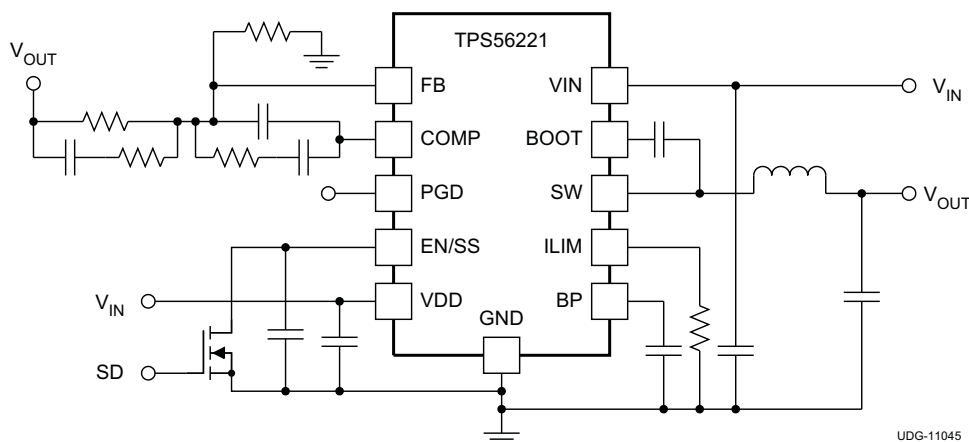

## 目录

<b>1</b>	特性 .....	<b>1</b>	7.3	Feature Description .....	<b>10</b>
<b>2</b>	应用范围 .....	<b>1</b>	7.4	Device Functional Modes .....	<b>14</b>
<b>3</b>	说明 .....	<b>1</b>	<b>8</b>	<b>Application and Implementation</b> .....	<b>15</b>
<b>4</b>	修订历史记录 .....	<b>2</b>	8.1	Application Information .....	<b>15</b>
<b>5</b>	<b>Pin Configuration and Functions</b> .....	<b>3</b>	8.2	Typical Application .....	<b>15</b>
<b>6</b>	<b>Specifications</b> .....	<b>4</b>	<b>9</b>	<b>Power Supply Recommendations</b> .....	<b>22</b>
6.1	Absolute Maximum Ratings .....	<b>4</b>	<b>10</b>	<b>Layout</b> .....	<b>22</b>
6.2	ESD Ratings .....	<b>4</b>	10.1	Layout Guidelines .....	<b>22</b>
6.3	Recommended Operating Conditions .....	<b>4</b>	10.2	Layout Example .....	<b>22</b>
6.4	Thermal Information .....	<b>5</b>	<b>11</b>	器件和文档支持 .....	<b>24</b>
6.5	Electrical Characteristics .....	<b>5</b>	11.1	器件支持 .....	<b>24</b>
6.6	Typical Characteristics .....	<b>7</b>	11.2	商标 .....	<b>24</b>
<b>7</b>	<b>Detailed Description</b> .....	<b>10</b>	11.3	静电放电警告 .....	<b>24</b>
7.1	Overview .....	<b>10</b>	11.4	术语表 .....	<b>24</b>
7.2	Functional Block Diagram .....	<b>10</b>	<b>12</b>	机械、封装和可订购信息 .....	<b>24</b>

## 4 修订历史记录

NOTE: Page numbers for previous revisions may differ from page numbers in the current version.

### Changes from Revision B (September 2012) to Revision C Page

- 已添加 引脚配置和功能部分, ESD 额定值表, 特性描述部分, 器件功能模式, 应用和实施部分, 电源相关建议部分, 布局部分, 器件和文档支持部分以及机械、封装和可订购信息部分..... **1**

### Changes from Revision A (JUNE 2012) to Revision B Page

- Corrected typographical error in 公式 6..... **18**

### Changes from Original (MARCH 2011) to Revision A Page

- 已添加 conditions to Electrical Characteristics table .....
- 已更改 characteristic data conditions .....
- 已更改 图 15 .....
- 已更改 图 16 .....
- 已更改 图 17 .....
- 已更改 图 18 .....
- 已添加 *Switching Node (SW)* section .....
- Changed replaced design example .....
- 已添加 *Layout Recommendations* section.....
- 已添加 *EVM Layout* section.....

## 5 Pin Configuration and Functions

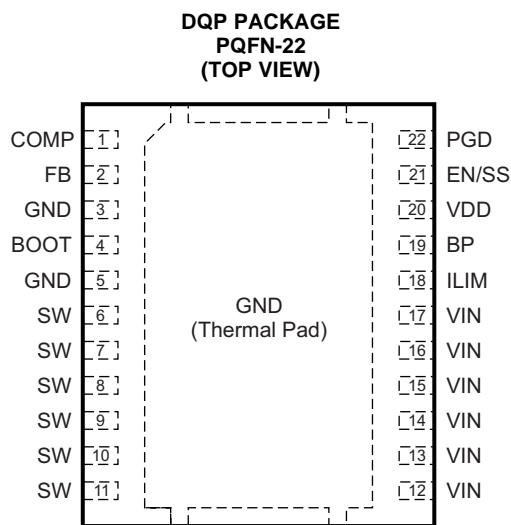

Note: The thermal pad is also an electrical ground connection.

### Pin Functions

PIN		I/O	DESCRIPTION
NAME	NO.		
BOOT	4	O	Gate drive voltage for the high-side FET. A 100-nF capacitor (typical) must be connected between this pin and the SW pin. To reduce a voltage spike at SW, a BOOT resistor between 5 $\Omega$ to 10 $\Omega$ may be placed in series with the BOOT capacitor to slow down turnon of the high-side FET.
BP	19	O	Output bypass for the internal regulator. Connect a low-ESR bypass ceramic capacitor of 1 $\mu$ F or greater from this pin to GND.
COMP	1	O	Output of the error amplifier and connection node for loop feedback components. Optionally, a 40.2-k $\Omega$ resistor from this pin to GND sets switching frequency to 300 kHz instead of the default value of 500 kHz; while a 13.3 k $\Omega$ resistor from this pin to GND sets switching frequency to 1 MHz.
EN/SS	21	I	Logic-level input starts or stops the controller via an external user command. Allowing this pin to float turns the controller on. Pulling this pin low disables the controller. This is also the soft-start programming pin. A capacitor connected from this pin to GND programs the soft-start time. The capacitor is charged with an internal current source of 10 $\mu$ A. The resulting voltage ramp of this pin is also used as a second noninverting input to the error amplifier after a 0.8 V (typical) level shift downwards. Output regulation is controlled by the internal level shifted voltage ramp until that voltage reaches the internal reference voltage of 600 mV. The voltage ramp of this pin reaches 1.4 V (typical).
FB	2	I	Inverting input to the error amplifier. In normal operation, the voltage on this pin is equal to the internal reference voltage.
GND	3	–	Ground reference for the device.
	5		
GND	Thermal Pad	–	Ground reference for the device. This is also the thermal pad used to conduct heat from the device. This connection serves two purposes. The first is to provide an electrical ground connection for the device. The second is to provide a low thermal impedance path from the device die to the PCB. This pad should be tied externally to a ground plane.
ILIM	18	I	A resistor connected from this pin to GND sets the overcurrent threshold for the device (the low-side FET).
PGD	22	O	Open-drain power good output.
SW	6	I	Switching node of the power conversion stage. Sense line for the adaptive anti-cross conduction circuitry. Acts as the common connection for the flying high-side FET driver.
	7		
	8		
	9		
	10		
	11		

**Pin Functions (continued)**

PIN		I/O	DESCRIPTION
NAME	NO.		
VDD	20	I	Power input to the controller. A low-ESR bypass ceramic capacitor of 1 $\mu$ F should be connected from this pin close to GND.
VIN	12	I	Power input to the high-side FET.
	13		
	14		
	15		
	16		
	17		

## 6 Specifications

### 6.1 Absolute Maximum Ratings

 over operating free-air temperature range (unless otherwise noted) <sup>(1)</sup>

		MIN	MAX	UNIT
Voltage	VDD, VIN	-0.3	16.5	V
	SW	-3	25	
	SW (< 100 ns pulse width, 10 $\mu$ J)	-5		
	BOOT	-0.3	30	
	BOOT-SW (differential from BOOT to SW)	-0.3	7	
	COMP, PGOOD, FB, BP, EN/SS, ILIM	-0.3	7	
Junction Temperature, T <sub>J</sub>		-40	150	°C
Storage temperature, T <sub>stg</sub>		-55	150	°C

- (1) Stresses beyond those listed under *Absolute Maximum Ratings* may cause permanent damage to the device. These are stress ratings only and functional operation of the device at these or any other condition beyond those included under *Recommended Operating Conditions* is not implied. Exposure to absolute-maximum-rated conditions for extended periods of time may affect device reliability.

### 6.2 ESD Ratings

		VALUE	UNIT
V <sub>(ESD)</sub>	Electrostatic discharge	Human body model (HBM), per ANSI/ESDA/JEDEC JS-001 <sup>(1)</sup>	$\pm$ 2000
		Charged-device model (CDM), per JEDEC specification JESD22-C101 <sup>(2)</sup>	$\pm$ 1500

- (1) JEDEC document JEP155 states that 500-V HBM allows safe manufacturing with a standard ESD control process.  
 (2) JEDEC document JEP157 states that 250-V CDM allows safe manufacturing with a standard ESD control process.

### 6.3 Recommended Operating Conditions

over operating free-air temperature range (unless otherwise noted)

		MIN	NOM	MAX	UNIT
V <sub>DD</sub>	VIN Input voltage	4.5		14	V
T <sub>J</sub>	Operating junction temperature	-40		125	°C

## 6.4 Thermal Information

THERMAL METRIC <sup>(1)</sup>		TPS56221		UNIT
		PQFN		
		22 PINS		
R <sub>θJA</sub>	Junction-to-ambient thermal resistance	34.6		°C/W
R <sub>θJC(top)</sub>	Junction-to-case (top) thermal resistance	22.9		
ψ <sub>JT</sub>	Junction-to-top characterization parameter	0.6		
ψ <sub>JB</sub>	Junction-to-board characterization parameter	5.0		
R <sub>θJC(bot)</sub>	Junction-to-case (bottom) thermal resistance	0.3		

(1) For more information about traditional and new thermal metrics, see the *IC Package Thermal Metrics* application report, [SPRA953](#).

## 6.5 Electrical Characteristics

–40°C ≤ T<sub>J</sub> ≤ 125°C, V<sub>VDD</sub> = 12 V, all parameters at zero power dissipation (unless otherwise noted)

PARAMETER		TEST CONDITIONS	MIN	TYP	MAX	UNIT
<b>VOLTAGE REFERENCE</b>						
V <sub>FB</sub>	FB input voltage	T <sub>J</sub> = 25°C, 4.5 V ≤ V <sub>VDD</sub> ≤ 14 V	597	600	603	mV
		–40°C ≤ T <sub>J</sub> ≤ 125°C, 4.5 V ≤ V <sub>VDD</sub> ≤ 14 V	594	600	606	
<b>INPUT SUPPLY</b>						
V <sub>VDD</sub>	Input supply voltage range		4.5		14	V
IV <sub>DDSD</sub>	Shutdown supply current	V <sub>EN/SS</sub> = 0.2 V		80	120	μA
IV <sub>DDQ</sub>	Quiescent, nonswitching	Let EN/SS float, V <sub>FB</sub> = 1 V		2.5	5.0	mA
V <sub>UVLO</sub>	UVLO ON Voltage		4.0		4.3	V
V <sub>UVLO(HYS)</sub>	UVLO hysteresis		500		700	mV
<b>ENABLE/SOFT-START</b>						
V <sub>IH</sub>	High-level input voltage, EN/SS		0.55	0.70	1.00	V
V <sub>IL</sub>	Low-level input voltage, EN/SS		0.27	0.30	0.33	V
I <sub>SS</sub>	Soft-start source current		8	10	12	μA
V <sub>SS</sub>	Soft-start voltage level – start of ramp		0.4	0.8	1.3	V
<b>BP REGULATOR</b>						
V <sub>BP</sub>	Output voltage	I <sub>BP</sub> = 10 mA	6.2	6.5	6.8	V
V <sub>DO</sub>	Regulator dropout voltage, V <sub>VDD</sub> – V <sub>BP</sub>	I <sub>BP</sub> = 25 mA, V <sub>VDD</sub> = 4.5 V		70	125	mV
<b>OSCILLATOR</b>						
f <sub>SW</sub>	Switching frequency	R <sub>COMP</sub> = 40.2 kΩ, 4.5 V ≤ V <sub>VDD</sub> ≤ 14 V	270	300	330	kHz
		R <sub>COMP</sub> = open, 4.5 V ≤ V <sub>VDD</sub> ≤ 14 V	450	500	550	kHz
		R <sub>COMP</sub> = 13.3 kΩ, 4.5 V ≤ V <sub>VDD</sub> ≤ 14 V	0.8	0.95	1.1	MHz
V <sub>RAMP</sub> <sup>(1)</sup>	Ramp amplitude		V <sub>VDD</sub> /6.6	V <sub>VDD</sub> /6	V <sub>VDD</sub> /5.4	V
<b>PWM</b>						
D <sub>MAX</sub> <sup>(1)</sup>	Maximum duty cycle	f <sub>sw</sub> = 300 kHz, V <sub>FB</sub> = 0 V, 4.5 V ≤ V <sub>VDD</sub> ≤ 14 V	93%			
		f <sub>sw</sub> = 500 kHz, V <sub>FB</sub> = 0 V, 4.5 V ≤ V <sub>VDD</sub> ≤ 14 V	90%			
		f <sub>sw</sub> = 1 MHz, V <sub>FB</sub> = 0 V, 4.5 V ≤ V <sub>VDD</sub> ≤ 14 V	85%			
t <sub>ON(min)</sub> <sup>(1)</sup>	Minimum controllable pulse width			100		ns
<b>ERROR AMPLIFIER</b>						

(1) Ensured by design. Not production tested

**Electrical Characteristics (接下页)**
 $-40^{\circ}\text{C} \leq T_J \leq 125^{\circ}\text{C}$ ,  $V_{\text{VDD}} = 12\text{ V}$ , all parameters at zero power dissipation (unless otherwise noted)

PARAMETER		TEST CONDITIONS	MIN	TYP	MAX	UNIT
GBWP <sup>(1)</sup>	Gain bandwidth product		10	24		MHz
A <sub>OL</sub> <sup>(1)</sup>	Open loop gain		60			dB
I <sub>IB</sub>	Input bias current (current out of FB pin)	V <sub>FB</sub> = 0.6 V			75	nA
I <sub>EAO P</sub>	Output source current	V <sub>FB</sub> = 0 V	1.5			mA
I <sub>EAO M</sub>	Output sink current	V <sub>FB</sub> = 1 V	1.5			mA
<b>POWER GOOD</b>						
V <sub>OV</sub>	Feedback upper voltage limit for PGOOD		655	675	700	mV
V <sub>UV</sub>	Feedback lower voltage limit for PGOOD		500	525	550	mV
V <sub>PGD-HYST</sub>	PGOOD hysteresis voltage at FB			30	45	mV
R <sub>PGD</sub>	PGOOD pull down resistance	V <sub>FB</sub> = 0 V, I <sub>FB</sub> = 5 mA		30	70	Ω
I <sub>PGDLK</sub>	PGOOD leakage current	550 mV < V <sub>FB</sub> < 655 mV, V <sub>PGOOD</sub> = 5 V		10	20	μA
<b>OUTPUT STAGE</b>						
R <sub>HI</sub>	High-side device resistance	T <sub>J</sub> = 25°C, (V <sub>BOOT-</sub> - V <sub>SW</sub> ) = 5.5 V		4.5	6.5	mΩ
R <sub>LO</sub>	Low side device resistance	T <sub>J</sub> = 25°C		1.9	2.7	mΩ
<b>OVERCURRENT PROTECTION (OCP)</b>						
t <sub>PSSC(min)</sub> <sup>(1)</sup>	Minimum pulse time during short circuit			250		ns
t <sub>BLNKH</sub> <sup>(1)</sup>	Switch leading-edge blanking pulse time (high-side detection)			150		
I <sub>OCH</sub>	OC threshold for high-side FET	T <sub>J</sub> = 25°C, (V <sub>BOOT-</sub> - V <sub>SW</sub> ) = 5.5 V	45	54	65	A
I <sub>ILIM</sub>	ILIM current source	T <sub>J</sub> = 25°C		10.0		μA
V <sub>OCLPRO</sub> <sup>(1)</sup>	Programmable OC range for low side FET	T <sub>J</sub> = 25°C	12		100	mV
t <sub>OFF</sub>	OC retry cycles on EN/SS pin			4		Cycle
<b>BOOT DIODE</b>						
V <sub>DFWD</sub>	Bootstrap diode forward voltage	I <sub>BOOT</sub> = 5 mA		0.8		V
<b>THERMAL SHUTDOWN</b>						
T <sub>JSD</sub> <sup>(1)</sup>	Junction shutdown temperature			145		°C
T <sub>JSDH</sub> <sup>(1)</sup>	Hysteresis			20		°C

## 6.6 Typical Characteristics

图 13 到 图 18 是在 2.5 英寸 × 2.5 英寸、0.062 英寸厚的 FR4 板上测量的，该板具有 4 层和 2 盎司铜，0.32-μH 输出电感器和 0.32 mΩ 的 DCR。

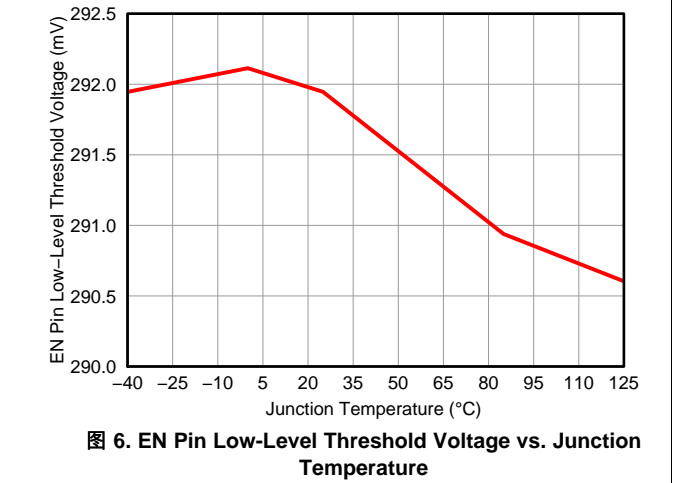
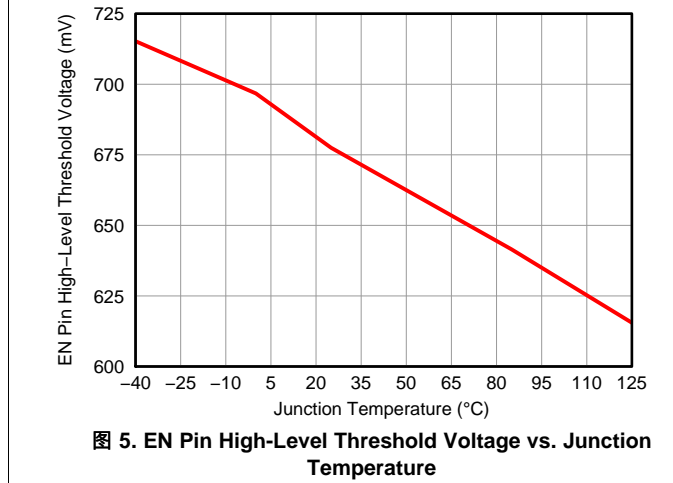
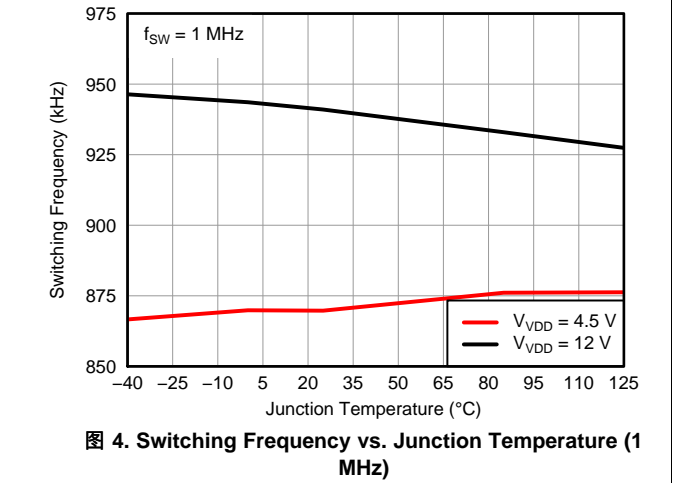
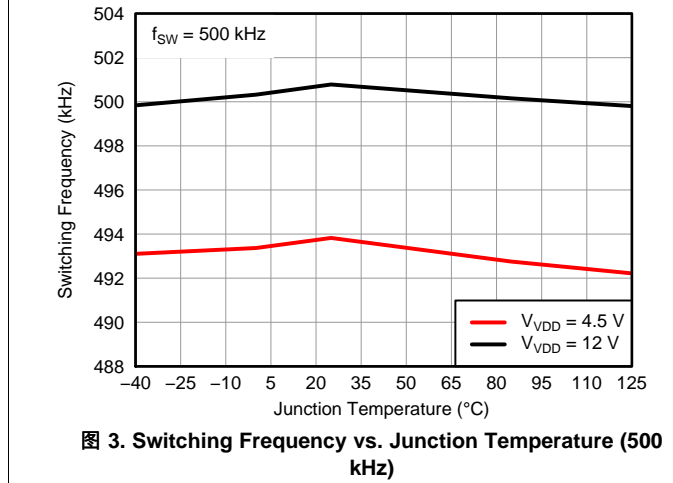
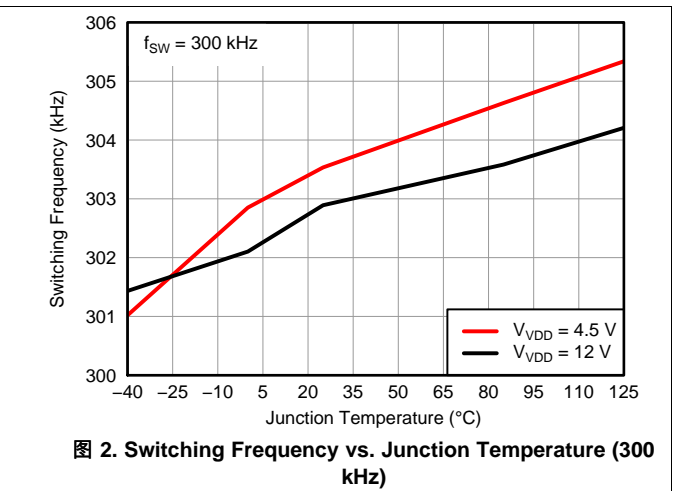
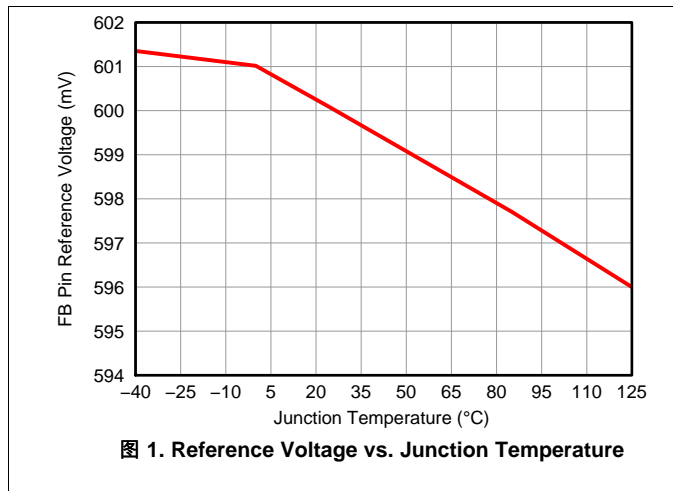

Typical Characteristics (接下页)

图 13 到 图 18 是在 2.5 英寸 x 2.5 英寸, 0.062 英寸厚 FR4 板上, 4 层板, 2-oz. 铜, 0.32-μH 输出电感器和 0.32 mΩ DCR 的条件下测量的。

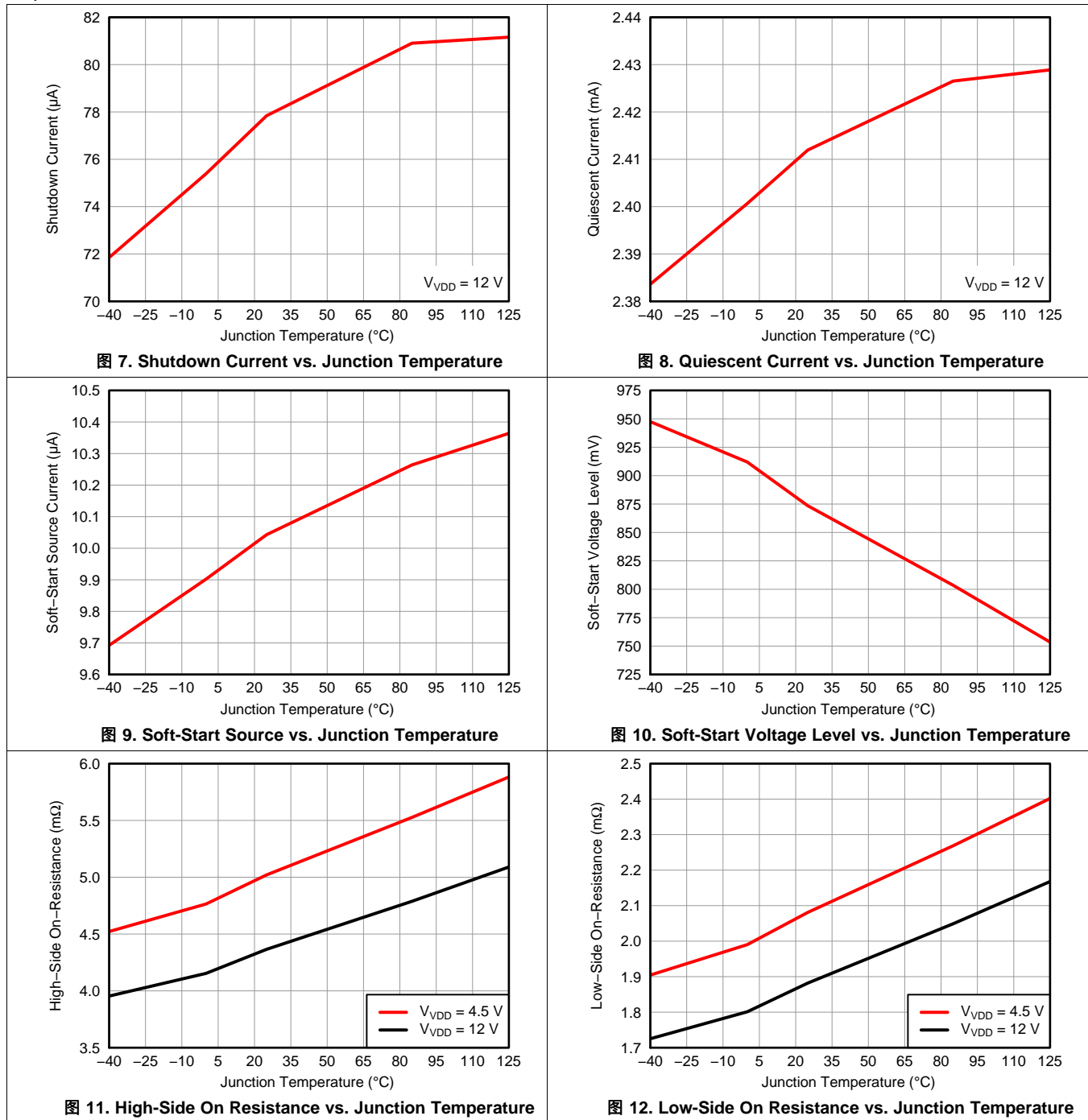

Typical Characteristics (接下页)

图 13 到 图 18 是在 2.5 英寸 x 2.5 英寸, 0.062 英寸厚 FR4 板上, 4 层板, 2-oz. 铜, 0.32-μH 输出电感器和 0.32 mΩ DCR 下测量的。



图 13. High-Side Overcurrent Threshold vs. Junction Temperature



图 14. Power Good Threshold Voltage vs. Junction Temperature

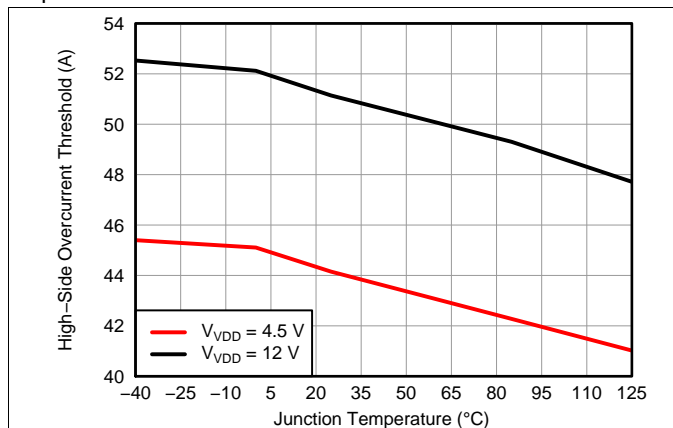

图 15. Efficiency vs. Load Current (VIN = 12 V)

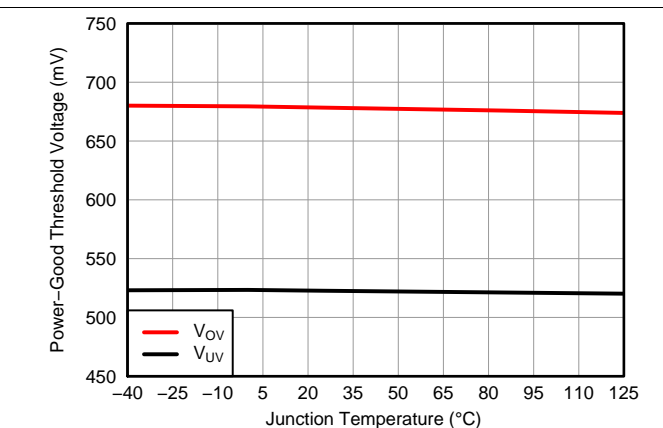

图 16. Efficiency vs. Load Current (VIN = 5 V)

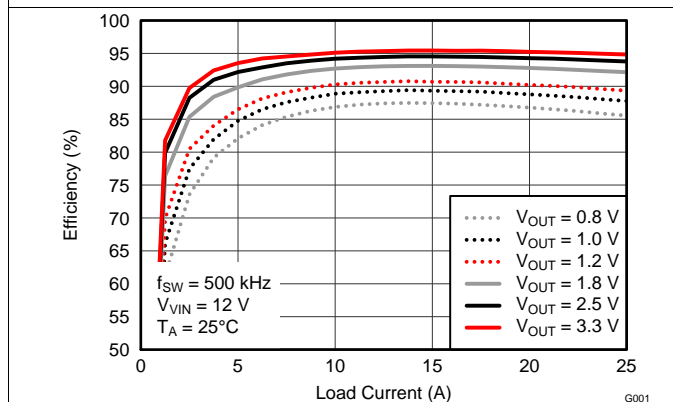

图 17. Output Current vs. Ambient Temperature (VIN = 12 V)

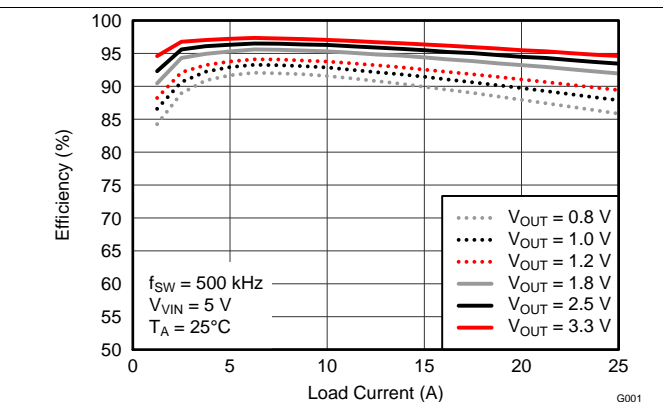

图 18. Output Current vs. Ambient Temperature (VIN = 5 V)

## 7 Detailed Description

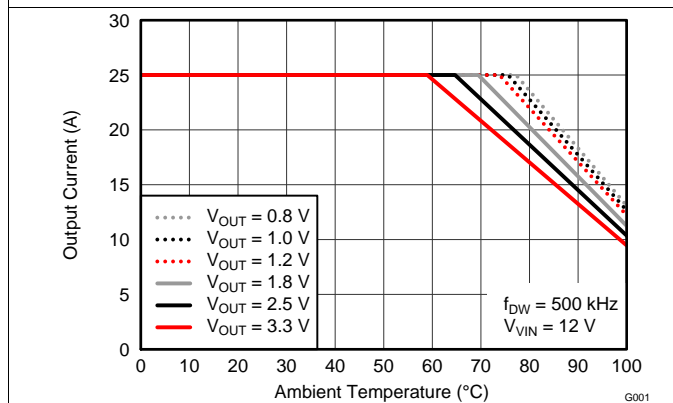
### 7.1 Overview

The TPS56221 is a 25-A high-performance synchronous buck converter with two integrated N-channel NexFET power MOSFETs. The device implements a voltage-mode control with voltage feed-forward compensation that responds instantly to input voltage change. Prebias capability eliminates concerns about damaging sensitive loads.

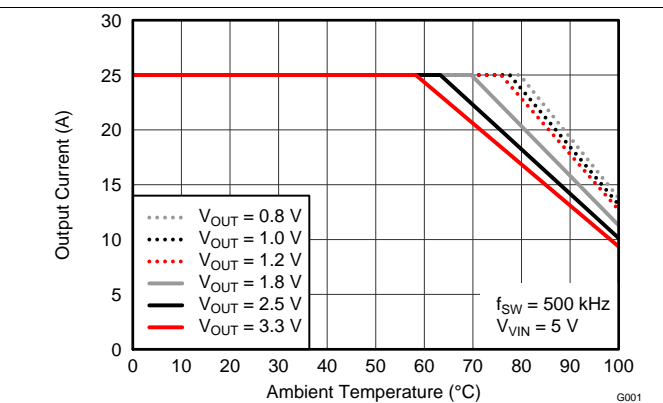
### 7.2 Functional Block Diagram

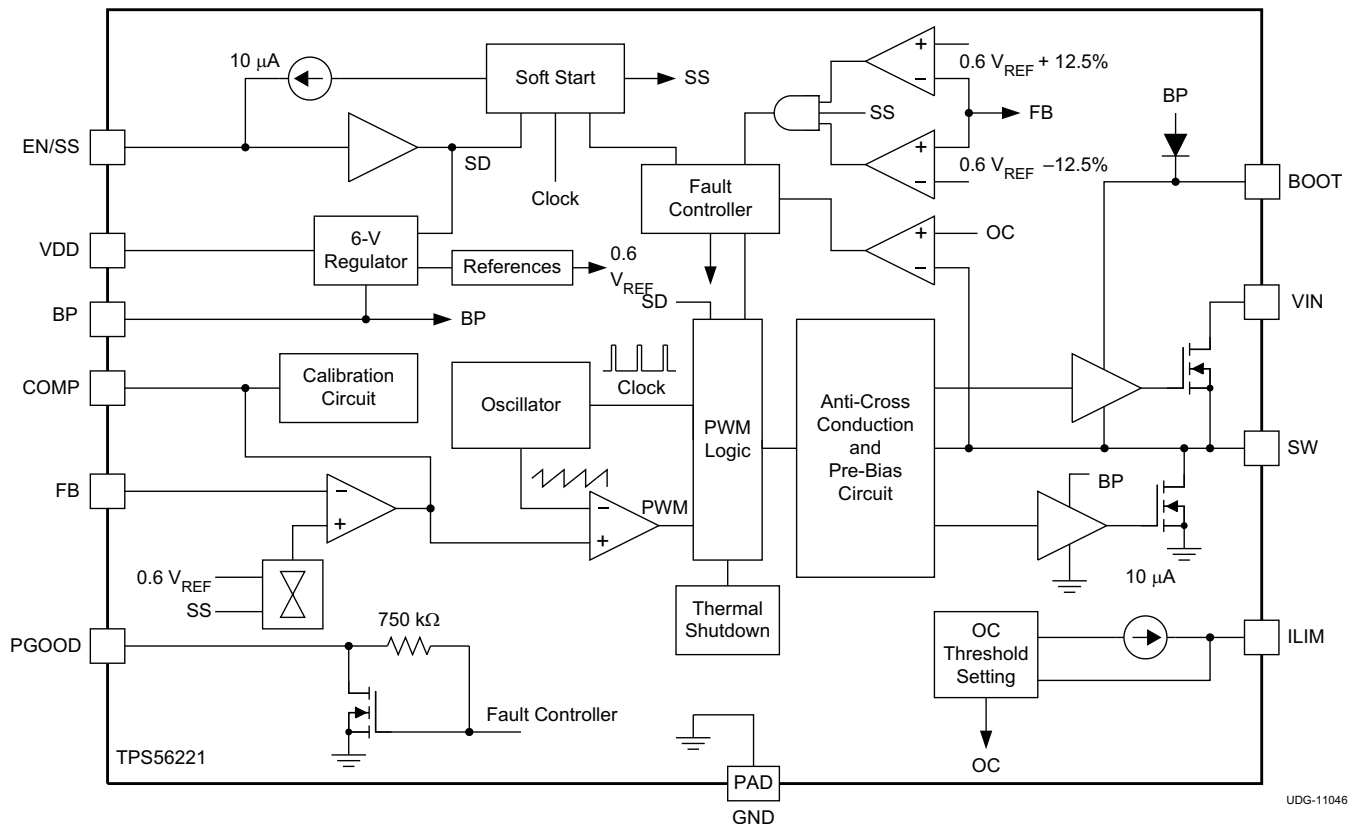

### 7.3 Feature Description

#### 7.3.1 Voltage Reference

The 600-mV bandgap cell is internally connected to the noninverting input of the error amplifier. The reference voltage is trimmed with the error amplifier in a unity gain configuration to remove amplifier offset from the final regulation voltage. The 1% tolerance on the reference voltage allows the user to design a very accurate power supply.

## Feature Description (接下页)



图 19. Start-Up Sequence and Timing

### 7.3.2 Enable Functionality, Start-Up, Sequence, and Timing

After input power is applied, an internal 40- $\mu$ A current source begins to charge the soft-start capacitor connected from EN/SS to GND. When the voltage across that capacitor increases to 0.7 V, it enables the internal BP regulator followed by a calibration. Total calibration time is approximately 1.9 ms. See 图 19. During the calibration, the device performs the following two functions.

#### 7.3.2.1 COMP Pin Impedance Sensing

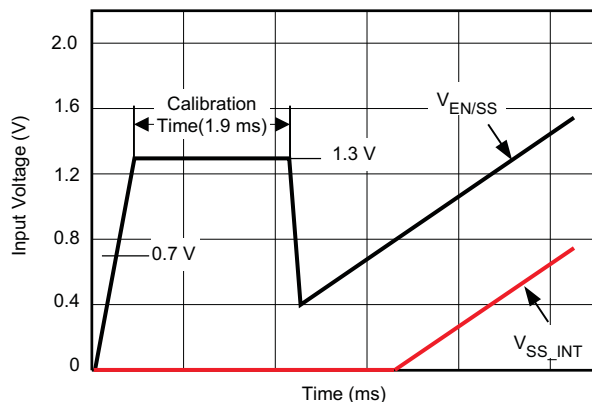
The device samples the impedance at the COMP pin and determines the appropriate operating switching frequency. If there is no resistor connected from the COMP pin to GND, the switching frequency is set to the default value of 500 kHz. If a resistor of 40.2 k $\Omega$   $\pm$  10% is connected from the COMP pin to GND, the switching frequency is set to 300 kHz. Alternatively, if a resistor of 13.3 k $\Omega$   $\pm$  10% is connected from the COMP pin to GND, the switching frequency is set to 1 MHz.

After a 1.1-ms time period, the COMP pin is then brought low for 0.8 ms. This ensures that the feedback loop is preconditioned at start-up and no sudden output rise occurs at the output of the converter when it is allowed to start switching.

#### 7.3.2.2 Overcurrent Protection (OCP) Setting

The device sources 10  $\mu$ A (typical) to the resistor connected from the ILIM pin to GND. The voltage developed across that resistor multiplied by a factor of 2 is then sampled and latched off internally as the OCP trip level for the low-side FET until one cycles the input or toggles the EN/SS.

The voltage at EN/SS is internally clamped to 1.3 V before and/or during calibration to minimize the discharging time once calibration is complete. The discharging current is from an internal current source of 140  $\mu$ A and it pulls the voltage down to 0.4 V. It then initiates the soft-start by charging up the capacitor using an internal current source of 10  $\mu$ A. The resulting voltage ramp on this pin is used as a second noninverting input to the error amplifier after an 800 mV (typical) downward level-shift; therefore, the actual soft-start does not take place until the voltage at this pin reaches 800 mV.

If the EN/SS pin is left floating, the controller starts automatically. EN/SS must be pulled down to less than 270 mV to ensure that the chip is in shutdown mode.

### 7.3.3 Soft-Start Time

The soft-start time of the TPS56221 is user programmable by selecting a single capacitor. The EN/SS pin sources 10  $\mu$ A to charge this capacitor. The actual output ramp-up time is the amount of time that it takes for the 10  $\mu$ A to charge the capacitor through a 600 mV range. There is some initial lag due to calibration and an offset (800 mV) from the actual EN/SS pin voltage to the voltage applied to the error amplifier.

## Feature Description (接下页)

The soft-start is accomplished in a closed-loop, meaning that the error amplifier controls the output voltage at all times during the soft-start period and the feedback loop is never open as occurs in duty cycle limit soft-start schemes. The error amplifier has two noninverting inputs, one connected to the 600-mV reference voltage, and the other connected to the offset EN/SS pin voltage. The lower of these two voltages is what the error amplifier controls the FB pin to. As the voltage on the EN/SS pin ramps up past approximately 1.4 V (800 mV offset voltage plus the 600 mV reference voltage), the 600-mV reference voltage becomes the dominant input and the converter has reached its final regulation voltage.

The capacitance required for a given soft-start ramp time for the output voltage is calculated in [公式 1](#).

$$C_{SS} = \left( \frac{I_{SS}}{V_{FB}} \right) \times t_{SS}$$

where

- $C_{SS}$  is the required capacitance on the EN/SS pin (nF)
  - $I_{SS}$  is the soft-start source current (10  $\mu$ A)
  - $V_{FB}$  is the feedback reference voltage (0.6 V)
  - $t_{SS}$  is the desired soft-start ramp time (ms)
- (1)

### 7.3.4 Oscillator

The oscillator frequency is internally fixed at 500 kHz if there is no resistor connected from COMP pin to GND. Optionally, a 40.2-k $\Omega$  resistor from the COMP pin to GND sets the frequency to 300 kHz. Alternatively, a 13.3-k $\Omega$  resistor from COMP pin GND sets the frequency to 1 MHz.

### 7.3.5 Overcurrent Protection (OCP)

Programmable OCP level at ILIM is from 6 mV to 50 mV. With a scale factor of 2, the actual OC trip point across the low-side FET is in the range of 12 mV to 100 mV.

If the voltage drop across  $R_{OCSET}$  reaches 300 mV during calibration (No  $R_{OCSET}$  resistor included), it disables OC protection. Once disabled, there is no low-side or high-side current sensing.

OCP level for the high-side FET is fixed at 54 A (typical). The high-side OCP provides pulse-by-pulse current limiting.

OCP sensing for the low-side FET is a true inductor valley current detection, using sample and hold. [公式 2](#) can be used to calculate  $R_{OCSET}$ :

$$R_{OCSET} = \left( I_{OUT(max)} - \left( \frac{I_{P-P}}{2} \right) \right) \times 95 + 62.5$$

where

- $I_{P-P}$  is the peak-to-peak inductor current (A)
  - $I_{OUT(max)}$  is the trip point for OCP (A)
  - $R_{OCSET}$  is the resistor used for setting the OCP level ( $\Omega$ )
- (2)

An overcurrent (OC) condition is detected by sensing voltage drop across the low-side FET and across the high-side FET. If the voltage drop across either FET exceeds OC threshold, a count increments one count. If no OC condition is detected on either FET, the fault counter decrements by one counter. If three OC pulses are summed, a fault condition is declared which cycles the soft-start function in a hiccup mode. Hiccup mode is defined as four dummy soft-start time-outs followed by a real one if overcurrent condition is encountered during normal operation; or five dummy soft-start time-outs followed by a real one if overcurrent condition occurs from the beginning during start. This cycle continues indefinitely until the fault condition is removed.

## Feature Description (接下页)

### 7.3.6 Switching Node (SW)

The SW pin connects to the switching node of the power conversion stage. It acts as the return path for the high-side gate driver. When configured as a synchronous buck stage, the voltage swing on SW normally traverses from below ground to well above the input voltage. Parasitic inductance in the high-side FET and the output capacitance ( $C_{OSS}$ ) of both power FETs form a resonant circuit that can produce high frequency ( $> 100$  MHz) ringing on this node. The voltage peak of this ringing, if not controlled, can be significantly higher than the input voltage. Ensure that the peak ringing amplitude does not exceed the absolute maximum rating limit for the pin.

In many cases, a series resistor and capacitor snubber network connected from the switching node to PGND can be helpful in damping the ringing and decreasing the peak amplitude. Provide provisions for snubber network components in the layout of the printed circuit board. If testing reveals that the ringing amplitude at the SW pin exceeds the limit, then include snubber components.

Placing a BOOT resistor with a value from  $5\ \Omega$  to  $10\ \Omega$  in series with the BOOT capacitor slows down the turnon of the high-side FET and can help to reduce the peak ringing at the switching node.

### 7.3.7 Input Undervoltage Lockout (UVLO)

The TPS56221 has fixed input UVLO. In order for the device to turn on, the following conditions must be met:

- The EN/SS pin voltage must be greater than  $V_{IH}$
- The input voltage must exceed UVLO on voltage  $V_{UVLO}$

The UVLO has a minimum of 500 mV hysteresis built-in.

### 7.3.8 Prebias Start-Up

The TPS56221 contains a unique circuit to prevent current from being pulled from the output during start-up in the condition the output is prebiased. There are no PWM pulses until the internal soft-start voltage rises above the error amplifier input (FB pin), if the output is prebiased. Once the soft-start voltage exceeds the error amplifier input, the controller slowly initiates synchronous rectification by starting the synchronous rectifier with a narrow on time. It then increments the on-time on a cycle-by-cycle basis until it coincides with the time dictated by  $(1-D)$ , where D is the duty cycle of the converter.

This approach prevents the sinking of current from a prebiased output, and ensures the output voltage start-up and ramp to regulation is smooth and controlled.

### 7.3.9 Power Good

The TPS56221 provides an indication that output is good for the converter. This is an open-drain signal and pulls low when any condition exists that would indicate that the output of the supply might be out of regulation. These conditions include:

- $V_{FB}$  is more than  $\pm 12.5\%$  from nominal
- soft-start function is active
- a short-circuit condition has been detected

---

#### 注

When there is no power to the device, PGOOD cannot pull close to GND if an auxiliary supply is used for the power good indication. In this case, a built-in resistor connected from drain to gate on the PGOOD pulldown device makes the PGOOD pin look approximately like a diode to GND.

---

### 7.3.10 Thermal Shutdown

If the junction temperature of the device reaches the thermal shutdown limit of  $145^{\circ}\text{C}$ , both high-side FET and low-side FET are kept off. When the junction cools to the required level ( $125^{\circ}\text{C}$  typical), the PWM initiates soft start as during a normal power-up cycle.

## 7.4 Device Functional Modes

The TPS56221 devices operate in continuous conduction mode (CCM) at a fixed frequency, regardless of the output current. For the first 128 switching cycles, the low-side MOSFET on-time is slowly increased to prevent excessive current sinking in the event the device is started with a prebiased output. Following the first 128 switching cycles, the low-side MOSFET and the high-side MOSFET on-times are fully complementary.

## 8 Application and Implementation

### 注

Information in the following applications sections is not part of the TI component specification, and TI does not warrant its accuracy or completeness. TI's customers are responsible for determining suitability of components for their purposes. Customers should validate and test their design implementation to confirm system functionality.

### 8.1 Application Information

The TPS56221 is highly integrated synchronous step-down DC-DC converters. The device is used to convert a higher DC input voltage (4.5 V to 14 V recommended) to a lower DC output voltage (as low as 0.6 V), with a maximum output current of 25 A, for a variety of applications. Use the following design procedure to select key component values for this device.

### 8.2 Typical Application

This design example describes a 25-A, 12-V to 1.0-V design using the TPS56221 high-current integrated buck converter. The system specifications are listed in [表 1](#).



图 20. Typical Application Schematic

TPS56221

ZHCS124C – MARCH 2011 – REVISED JANUARY 2015

www.ti.com.cn

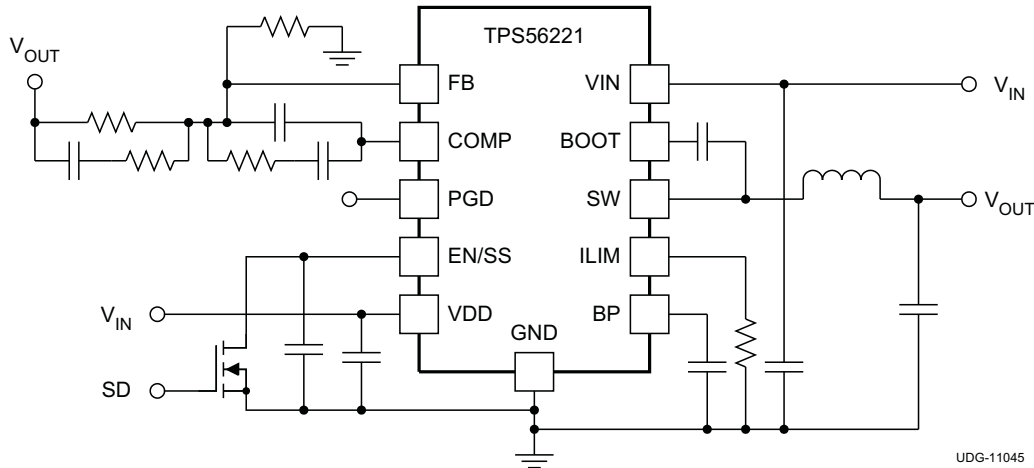

图 21. Design Example Schematic

## 8.2.1 Design Requirements

**表 1. Design Example Parameters**

PARAMETER		TEST CONDITIONS	MIN	TYP	MAX	UNIT
$V_{IN}$	Input voltage		8.0		14	V
$V_{IN(ripple)}$	Input ripple	$I_{OUT} = 25\text{ A}$			0.2	V
$V_{OUT}$	Output voltage	$0\text{ A} \leq I_{OUT} \leq 25\text{ A}$	0.98	1.00	1.02	V
	Line regulation	$8\text{ V} \leq V_{IN} \leq 14\text{ V}$			0.1%	
	Load regulation	$0\text{ A} \leq I_{OUT} \leq 25\text{ A}$			1.0%	
$V_{P-P}$	Output ripple	$I_{OUT} = 25\text{ A}$		20		mV
$V_{OVER}$	Output overshoot	$I_{TRAN} = 10\text{ A}$		100		mV
$V_{UNDER}$	Output undershoot	$I_{TRAN} = 10\text{ A}$		100		mV
$I_{OUT}$	Output current	$8\text{ V} \leq V_{IN} \leq 14\text{ V}$	0		25	A
$t_{SS}$	Softstart time	$V_{IN} = 12\text{ V}$		2.0		ms
$I_{SCP}$	Short circuit current trip point		32			A
$\eta$	Efficiency	$V_{IN} = 12\text{ V}, I_{OUT} = 25\text{ A}$		87%		
$f_{SW}$	Switching frequency			500		kHz

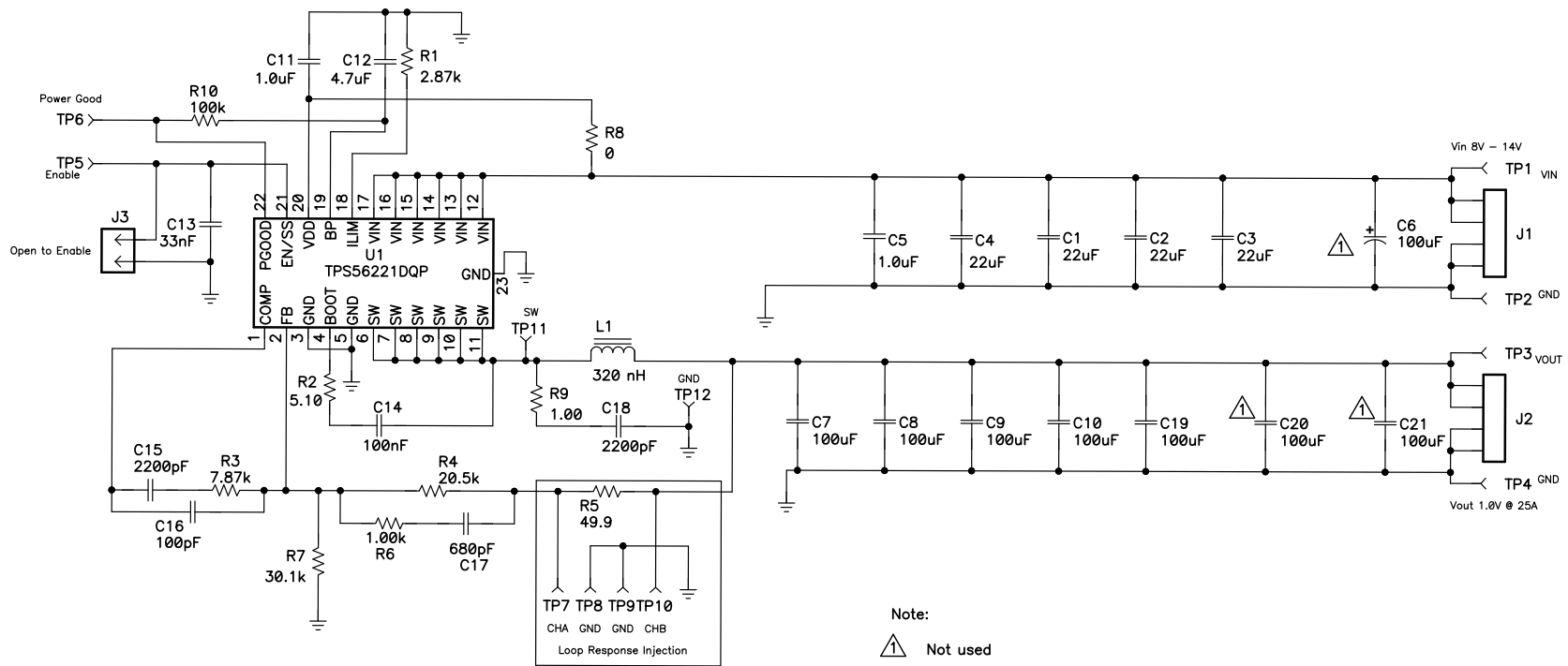
## 8.2.2 Detailed Design Procedure

**表 2. List of Materials for TPS56221 Design Example**

REFERENCE DESIGNATOR	QTY	VALUE	DESCRIPTION	SIZE	PART NUMBER	MANUFACTURER
C1, C2, C3, C4	4	22 $\mu\text{F}$	Capacitor, Ceramic, 25 V, X5R, 20%	1210	Std	Std
C5, C11	2	1.0 $\mu\text{F}$	Capacitor, Ceramic, 25 V, X7R, 20%	0805	Std	Std
C6	0	100 $\mu\text{F}$	Capacitor, Ceramic, 16 Vdc, $\pm 20\%$	Code D8	Std	EEEF1C101AP
C7, C8, C9, C10, C19	5	100 $\mu\text{F}$	Capacitor, Ceramic, 6.3 V, X5R, 20%	1210	Std	Std
C12	1	4.7 $\mu\text{F}$	Capacitor, Ceramic, 10 V, X5R, 20%	0805	Std	Std
C13	1	33 nF	Capacitor, Ceramic, 16 V, X7R, 20%	0603	Std	Std
C14	1	100 nF	Capacitor, Ceramic, 16V, X7R, 20%	0402	Std	Std
C15, C18	2	2200 pF	Capacitor, Ceramic, 50 V, X7R, 10%	0603	Std	Std
C16	1	100 pF	Capacitor, Ceramic, 50 V, C0G, 10%	0603	Std	Std
C17	1	680 pF	Capacitor, Ceramic, 50 V, C0G, 10%	0603	Std	Std
C20, C21	0	100 $\mu\text{F}$	Capacitor, Ceramic, 6.3 V, X5R, 20%	1210	Std	Std
J1, J2	2		Terminal Block, 4-pin, 15-A, 5.1 mm	0.80 x 0.35 inch	ED120/4DS	
J3	1		Header, Male 2-pin, 100 mil spacing	0.100 inch x 2	PEC02SAAN	
L1	1	320 nH	Inductor, 320 nH, 41 A, 0.32 m $\Omega$	0.530 x 0.510 inch	PA2202-321NL	Pulse
R1	1	1.78 k $\Omega$	Resistor, Chip, 1/16W, 1%	0603	Std	Std
R2	1	5.10 $\Omega$	Resistor, Chip, 1/16W, 1%	0603	Std	Std
R3	1	7.87 k $\Omega$	Resistor, Chip, 1/16W, 1%	0603	Std	Std
R4	1	20.5 k $\Omega$	Resistor, Chip, 1/16W, 1%	0603	Std	Std
R5		49.9 $\Omega$	Resistor, Chip, 1/16W, 1%	0603		
R6	1	1.00 k $\Omega$	Resistor, Chip, 1/16W, 1%	0603	Std	Std
R7	1	30.1 k $\Omega$	Resistor, Chip, 1/16W, 1%	0603	Std	Std
R8	1	0 $\Omega$	Resistor, Chip, 1/16W, 1%	0603		
R9	1	1 $\Omega$	Resistor, Chip, 1/16W, 1%	0603		
R10	1	100 k $\Omega$	Resistor, Chip, 1/16W, 1%	0603		

**表 2. List of Materials for TPS56221 Design Example (接下页)**

REFERENCE DESIGNATOR	QTY	VALUE	DESCRIPTION	SIZE	PART NUMBER	MANUFACTURER
TP1, TP3, TP11	3		Test Point, Red, Thru Hole	0.125 x 0.125 inch	5010	
TP2, TP4, TP8, TP9, TP12	5		Test Point, Black, Thru Hole	0.125 x 0.125 inch	5011	
TP5, TP6	2		Test Point, Yellow, Thru Hole	0.125 x 0.125 inch	5014	
TP7, TP10	2		Test Point, White, Thru Hole	0.125 x 0.125 inch	5012	
U1	1	QFN-22	4.5-V to 14-V Input, 25-A, synchronous buck converter	6 x 5 mm	TPS56221DQP	TI

### 8.2.2.1 Switching Frequency Selection

To achieve a balance between small size and high efficiency for this design, use switching frequency of 500 kHz.

### 8.2.2.2 Inductor Selection

Synchronous buck power inductors are typically sized for between approximately 20% and 40% peak-to-peak ripple current ( $I_{P-P}$ ).

Using this target ripple current, the required inductor size can be calculated as shown in 公式 3.

$$L \approx \frac{V_{IN(max)} - V_{OUT}}{0.3 \times I_{OUT}} \times \frac{V_{OUT}}{V_{IN(max)}} \times \frac{1}{f_{SW}} = \frac{14V - 1.0V}{0.3 \times 25A} \times \frac{1.0V}{14V} \times \frac{1}{500kHz} = 186nH \quad (3)$$

Selecting a standard 320-nH inductor value,  $I_{P-P} = 5.8A$ .

The RMS current through the inductor is approximated in 公式 4.

$$I_{L(rms)} = \sqrt{\left(I_{L(avg)}\right)^2 + \left(\frac{1}{12} \times I_{RIPPLE}\right)^2} = \sqrt{\left(I_{OUT}\right)^2 + \left(\frac{1}{12} \times I_{P-P}\right)^2} = \sqrt{(25)^2 + \left(\frac{1}{12} \times (5.8)\right)^2} = 25.06A \quad (4)$$

### 8.2.2.3 Output Capacitor Selection

The selection of the output capacitor is typically driven by the output transient response. For applications with  $V_{IN(min)} > 2 \times V_{OUT}$ , use overshoot to calculate the minimum output capacitance and the equation is shown in 公式 5.

$$C_{OUT(min)} = \frac{\left(I_{TRAN}\right)^2 \times L}{V_{OUT} \times V_{OVER}} = \frac{(10)^2 \times 320nH}{1.0 \times 100mV} = 320\mu F \quad (5)$$

For applications where  $V_{IN(min)} < 2 \times V_{OUT}$ , use undershoot to calculate minimum output capacitance. The equation is shown in 公式 6.

$$C_{OUT(min)} = \frac{\left(I_{TRAN}\right)^2 \times L}{\left(V_{IN} - V_{OUT}\right) \times V_{UNDER}} \quad (6)$$

To meet the low ESR and high-capacitance requirements of this design, five 100- $\mu F$ , 1210 ceramic capacitors are selected. With a minimum capacitance, the maximum allowable ESR is determined by the maximum ripple voltage and is approximated by 公式 7.

$$ESR_{C_{OUT(max)}} = \frac{V_{RIPPLE} - V_{RIPPLE(C_{OUT})}}{I_{P-P}} = \frac{V_{RIPPLE} - \left(\frac{I_{P-P}}{8 \times C_{OUT} \times f_{SW}}\right)}{I_{P-P}} = \frac{20mV - \left(\frac{5.8A}{8 \times 500\mu F \times 500kHz}\right)}{5.8A} = 2.9m\Omega \quad (7)$$

### 8.2.2.4 Inductor Peak Current Rating

With output capacitance, it is possible to calculate the charge current during start-up and determine the minimum saturation current rating for the inductor. The start-up charging current is approximated by 公式 8.

$$I_{\text{CHARGE}} = \frac{V_{\text{OUT}} \times C_{\text{OUT}}}{t_{\text{SS}}} = \frac{1.0 \text{ V} \times 500 \mu\text{F}}{2 \text{ ms}} = 0.25 \text{ A} \quad (8)$$

The peak current in the inductor  $I_{L(\text{peak})}$  is approximated by 公式 9.

$$I_{L(\text{peak})} = I_{\text{OUT}(\text{max})} + \left(\frac{1}{2} \times I_{\text{RIPPLE}}\right) + I_{\text{CHARGE}} = 25 \text{ A} + \left(\frac{1}{2} \times 5.8 \text{ A}\right) + 0.25 \text{ A} = 28.2 \text{ A} \quad (9)$$

With the short circuit current trip point  $I_{\text{OUT}(\text{max})}$  set at 32 A, the maximum allowable peak current  $I_{L(\text{peak max})}$  is

$$I_{L(\text{peak max})} = I_{\text{OUT}(\text{max})} + \left(\frac{1}{2} \times I_{\text{RIPPLE}}\right) = 30 \text{ A} + \left(\frac{1}{2} \times 5.8 \text{ A}\right) = 32.9 \text{ A} \quad (10)$$

The selection of output capacitor meets the maximum allowable peak current requirement.

**表 3. Inductor Requirements Summary**

PARAMETER		VALUE	UNIT
L	Inductance	320	nH
$I_{L(\text{rms})}$	RMS current (thermal rating)	25.1	A
$I_{L(\text{peak max})}$	Peak current (saturation rating)	32.9	A

The PA0513.321NLT, 320-nH, 0.32-mΩ, 41-A inductor is selected.

### 8.2.2.5 Input Capacitor Selection

The input voltage ripple is divided between capacitance and ESR. For this design  $V_{\text{IN\_RIPPLE}(\text{CAP})} = 150 \text{ mV}$  and  $V_{\text{IN\_RIPPLE}(\text{ESR})} = 50 \text{ mV}$ . The minimum capacitance and maximum ESR are estimated in 公式 11.

$$C_{\text{IN}(\text{min})} = \frac{I_{\text{OUT}} \times V_{\text{OUT}}}{V_{\text{IN\_RIPPLE}(\text{CAP})} \times V_{\text{IN}(\text{min})} \times f_{\text{SW}}} = \frac{25 \times 1.0 \text{ V}}{150 \text{ mV} \times 8 \text{ V} \times 500 \text{ kHz}} = 41.7 \mu\text{F} \quad (11)$$

$$\text{ESR}_{\text{CIN}(\text{max})} = \frac{V_{\text{IN\_RIPPLE}(\text{ESR})}}{I_{\text{OUT}} + \frac{1}{2}(I_{\text{P-P}})} = \frac{50 \text{ mV}}{25 \text{ A} + \frac{1}{2}(5.8 \text{ A})} = 1.8 \text{ m}\Omega \quad (12)$$

The RMS current in the input capacitors is estimated by 公式 13.

$$I_{\text{RMS}(\text{cin})} = I_{\text{LOAD}} \times \sqrt{D \times (1-D)} = 25 \text{ A} \times \sqrt{\frac{1}{8} \times \left(1 - \frac{1}{8}\right)} = 8.3 \text{ A}_{\text{RMS}} \quad (13)$$

Four 1210, 22-μF, 25-V, X5R ceramic capacitors with about 2.5-mΩ of ESR and a 2.5-A RMS current rating are selected. Higher voltage capacitors are selected to minimize capacitance loss at the DC bias voltage to ensure the capacitors will have sufficient capacitance at the working voltage while a 1.0-μF capacitor in smaller case size is used to reduce high frequency noise from the MOSFET switching.

### 8.2.2.6 Boot-Strap Capacitor (C14)

The bootstrap capacitor maintains power to the high-side driver during the high-side switch ON time. Per the requirements of the integrated MOSFET,  $C_{\text{BOOT}}$  is 100 nF with a minimum 10-V rating.

### 8.2.2.7 Boot-Strap Resistor (R2)

The bootstrap resistor slows the rising edge of the SW voltage to reduce ringing and improve EMI. Per the datasheet recommendation a 5.10-Ω resistor is selected.

#### 8.2.2.7.1 RC Snubber (R9 and C18)

To effectively limit the switch node ringing, a 1.0-Ω resistor and a 2200-pF capacitor are selected.

### 8.2.2.8 VDD Bypass Capacitor (C11)

In accordance with pin terminations recommended in the data sheet, VDD is bypassed to GND with a 1.0-μF capacitor.

### 8.2.2.9 BP5 Bypass Capacitor (C12)

Per the datasheet recommended pin terminations, BP5 is bypassed to GND with at least 1.0-μF capacitor. For additional filtering and noise immunity a 4.7-μF capacitor is selected.

### 8.2.2.10 Soft-Start Capacitor (C13)

The soft-start capacitor provides a constant ramp voltage to the error amplifier to provide controlled, smooth start-up. The soft-start capacitor is sized using 公式 14.

$$C_{SS} = \frac{I_{SS}}{V_{FB}} \times t_{SS} = \frac{10 \mu\text{A}}{0.6 \text{V}} \times 2.0 \text{ms} = 33 \text{nF} \quad (14)$$

### 8.2.2.11 Current Limit (R1)

The TPS56221 uses the negative drop across the internal low-side FET at the end of the OFF-time to measure the valley of the inductor current. Allowing for a minimum of 30% over maximum load, the programming resistor is selected using 公式 15.

$$R_{OCSET} = 95 \times \left( I_{OUT(max)} - \left( \frac{I_{P-P}}{2} \right) \right) + 62.5 \Omega = 95 \times \left( 30 \text{ A} - \left( \frac{5.8 \text{ A}}{2} \right) \right) + 62.5 \Omega = 2.83 \text{ k}\Omega \quad (15)$$

A standard 2.87-kΩ resistor is selected from the E-48 series.

### 8.2.2.12 Feedback Divider (R4, R7)

The TPS56221 converter uses a full operational amplifier with an internally fixed 0.600-V reference. R4 is selected between 10 kΩ and 50 kΩ for a balance of feedback current and noise immunity. With R4 set to 20.5 kΩ, The output voltage is programmed with a resistor divider given by 公式 16.

$$R7 = \frac{V_{FB} \times R4}{(V_{OUT} - V_{FB})} = \frac{0.600 \text{V} \times 20.5 \text{k}\Omega}{1.0 \text{V} - 0.600 \text{V}} = 30.8 \text{k}\Omega \quad (16)$$

A standard 30.1-kΩ resistor is selected from the E-48 series.

### 8.2.2.13 Compensation (C15, C16, C17, R3, R6)

Using the *TPS40k Loop Stability Tool* for 50 kHz of bandwidth and 60 degrees of phase margin with an R4 value of 20.5 kΩ, the following values are obtained.

- C17 = C\_1 = 680 pF
- C15 = C\_2 = 2200 pF
- C16 = C\_3 = 100 pF
- R6 = R\_2 = 1.00 kΩ
- R3 = R\_3 = 7.87 kΩ

### 8.2.3 Application Curves

Output voltage 12 V to 1.0 V, input current 0 A to 25 A.

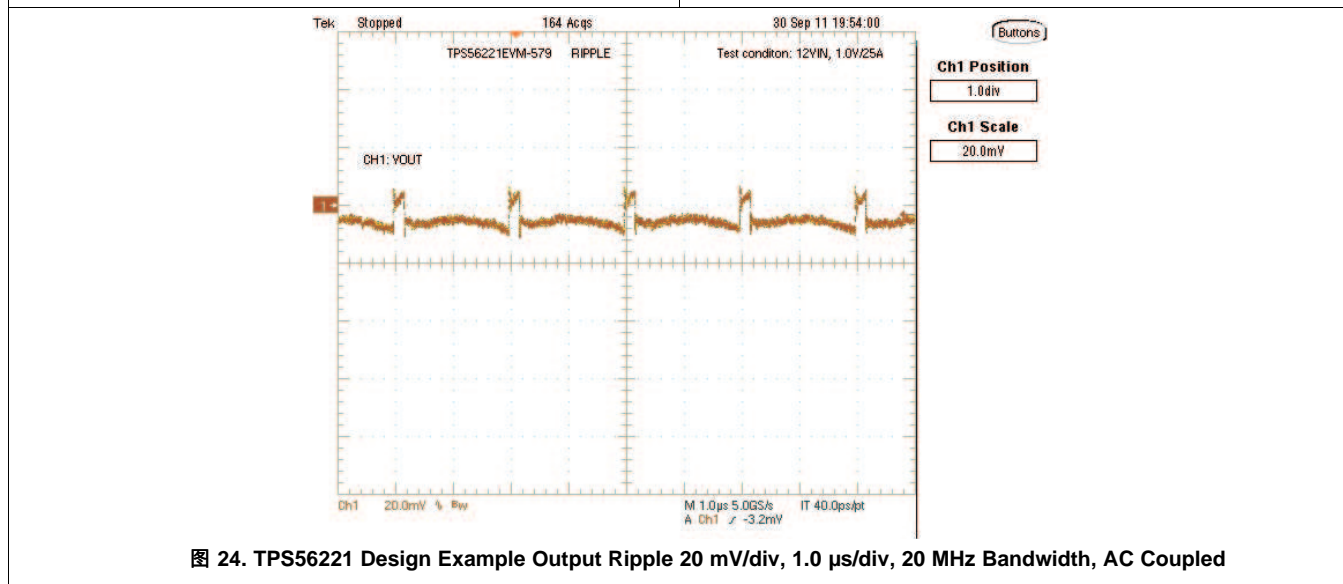
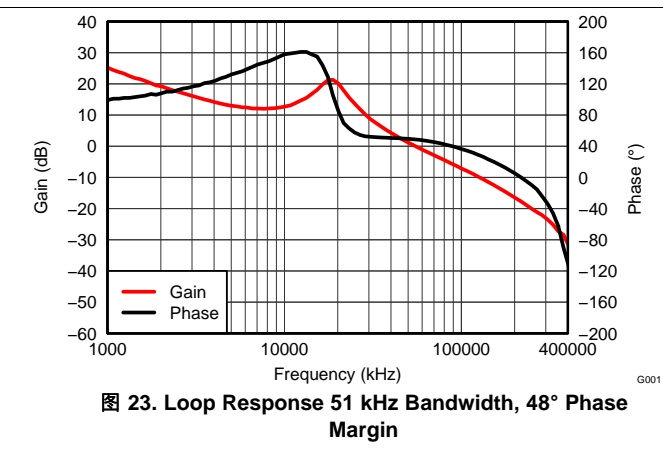
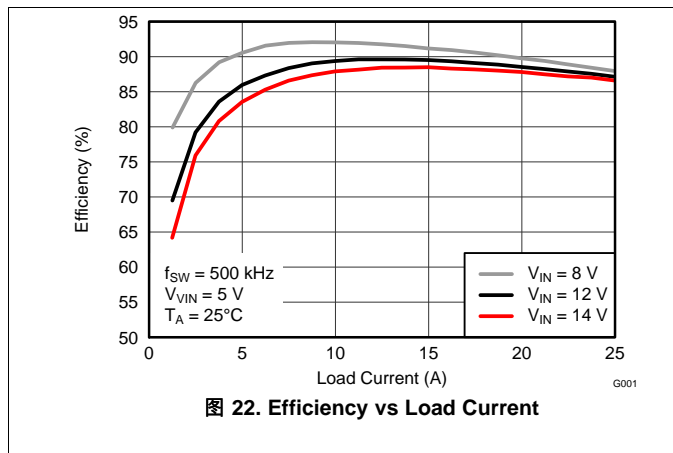

## 9 Power Supply Recommendations

The TPS56221 devices are designed to operate from an input voltage supply between 4.5 V and 14 V. This supply must be well regulated. These devices are not designed for split-rail operation. The VIN and VDD terminals must be the same potential for accurate high-side short circuit protection. Proper bypassing of input supplies and internal regulators is also critical for noise performance, as is PCB layout and grounding scheme. See the recommendations in [Layout Guidelines](#).

## 10 Layout

### 10.1 Layout Guidelines

- Place input capacitors next to the VIN pin and on the same side as the device. Use wide and short traces or copper planes for the connection from the VIN pin to the input capacitor and from the input capacitor to the power pad of the device.
- Place the BP decoupling capacitor close to the BP pin and on the same side as the device in order to avoid the use of vias. Use wide and short traces for the connection from the BP pin to the capacitor and from the capacitor to the power pad. If vias are not evitable, use at least three vias to reduce the parasitic inductance.
- Include a Kelvin VDD connection, or separate from VIN connection (bypass input capacitors); add a placeholder for a filter resistor between the VDD pin and the input bus. Place the VDD decoupling capacitor near the VDD pin and on the same side as the device to avoid the use of vias. Use wide and short traces for the connection from the VDD pin to the capacitor and from the capacitor to the power pad of the device. If vias are not avoidable, use at least three vias to reduce the parasitic inductance.
- Maintain the FB trace away from BOOT and SW traces.
- Minimize the area of switch node.
- Use a single ground. Do not use separate signal and power ground.
- Use 3 × 7 thermal vias as suggested in *Land Pattern Data* in [机械、封装和可订购信息](#).

### 10.2 Layout Example

The TPS56221EVM layout is shown in [图 25](#) through [图 30](#) for reference.

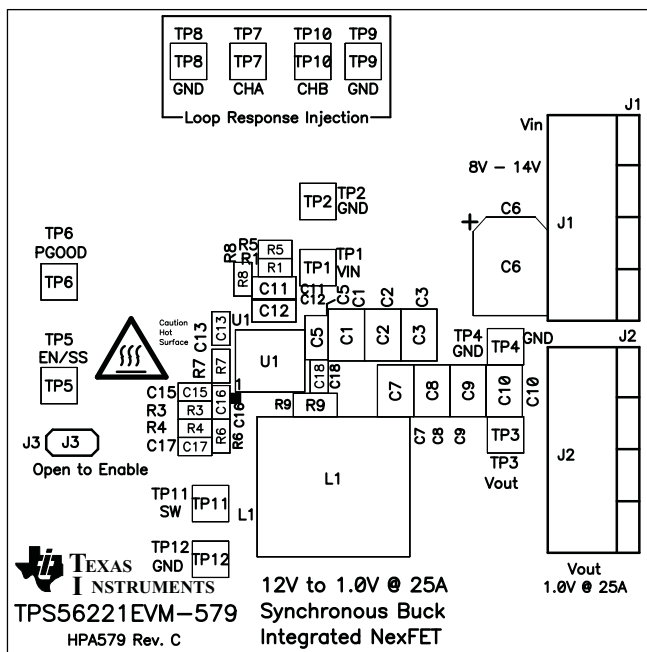

**图 25. TPS56221EVM Top Assembly Drawing (Top view)**

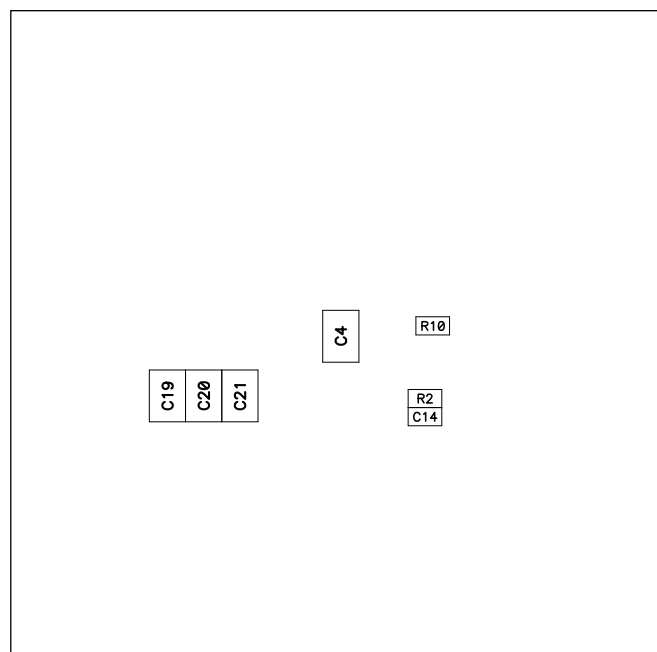

**图 26. TPS56221EVM Bottom Assembly Drawing (Bottom view)**

Layout Example (接下页)



图 27. TPS56221EVM Top Copper (Top View)



图 28. TPS56221EVM Internal 1 (Top View)

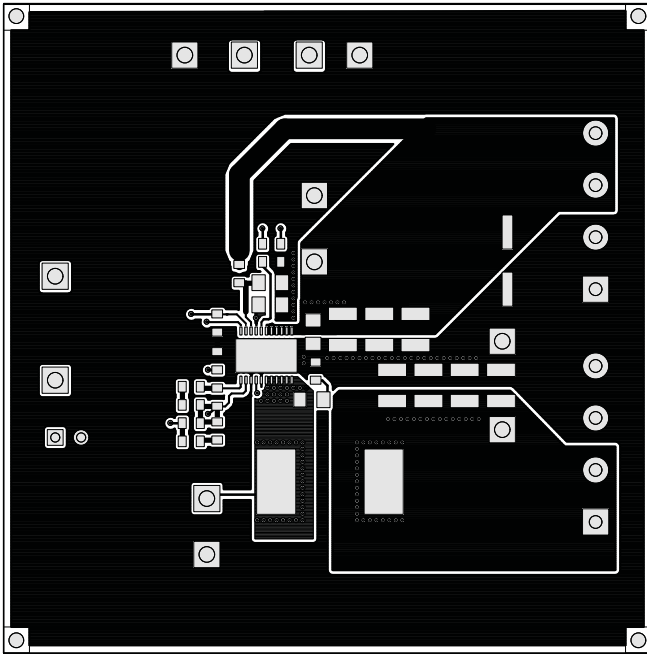

图 29. TPS56221EVM Internal 2 (Top View)

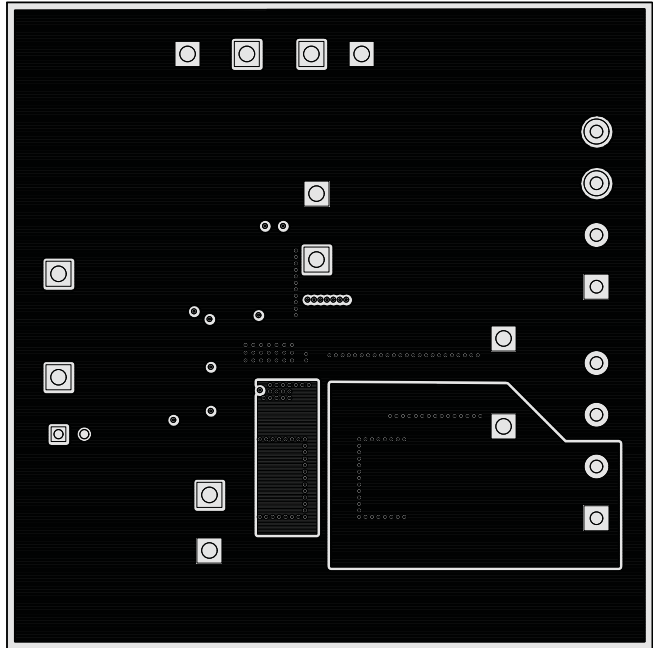

图 30. TPS56221EVM Bottom Copper (Top View)

## 11 器件和文档支持

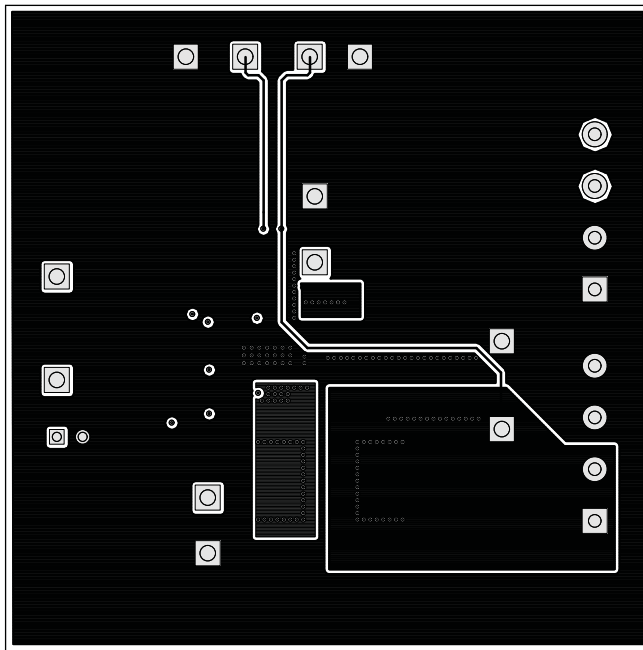
### 11.1 器件支持

#### 11.1.1 第三方产品免责声明

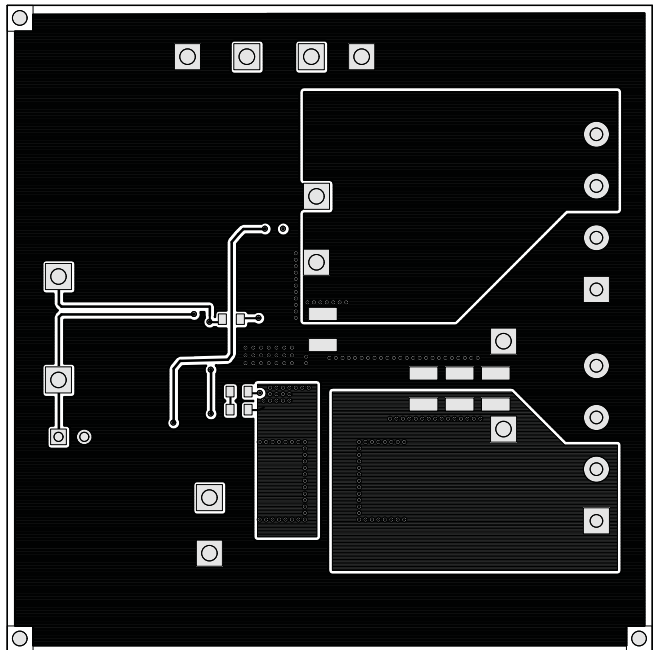
TI 发布的与第三方产品或服务有关的信息，不能构成与此类产品或服务或保修的适用性有关的认可，不能构成此类产品或服务单独或与任何 TI 产品或服务一起的表示或认可。

### 11.2 商标

PowerPAD, NexFET are trademarks of Texas Instruments.  
All other trademarks are the property of their respective owners.

### 11.3 静电放电警告



这些装置包含有限的内置 ESD 保护。存储或装卸时，应将导线一起截短或将装置放置于导电泡棉中，以防止 MOS 门极遭受静电损伤。

### 11.4 术语表



[SLYZ022](#) — TI 术语表。

这份术语表列出并解释术语、首字母缩略词和定义。

## 12 机械、封装和可订购信息

以下页中包括机械、封装和可订购信息。 这些信息是针对指定器件可提供的最新数据。 这些数据会在无通知且不  
对本文档进行修订的情况下发生改变。 欲获得该数据表的浏览器版本，请查阅左侧的导航栏。

**PACKAGING INFORMATION**

Orderable Device	Status (1)	Package Type	Package Drawing	Pins	Package Qty	Eco Plan (2)	Lead finish/ Ball material (6)	MSL Peak Temp (3)	Op Temp (°C)	Device Marking (4/5)	Samples
TPS56221DQPR	ACTIVE	LSON-CLIP	DQP	22	2500	RoHS-Exempt & Green	NIPDAU   SN	Level-2-260C-1 YEAR	-40 to 125	TPS56221	
TPS56221DQPT	ACTIVE	LSON-CLIP	DQP	22	250	RoHS-Exempt & Green	NIPDAU   SN	Level-2-260C-1 YEAR	-40 to 125	TPS56221	

(1) The marketing status values are defined as follows:

**ACTIVE:** Product device recommended for new designs.

**LIFEBUY:** TI has announced that the device will be discontinued, and a lifetime-buy period is in effect.

**NRND:** Not recommended for new designs. Device is in production to support existing customers, but TI does not recommend using this part in a new design.

**PREVIEW:** Device has been announced but is not in production. Samples may or may not be available.

**OBSOLETE:** TI has discontinued the production of the device.

(2) **RoHS:** TI defines "RoHS" to mean semiconductor products that are compliant with the current EU RoHS requirements for all 10 RoHS substances, including the requirement that RoHS substance do not exceed 0.1% by weight in homogeneous materials. Where designed to be soldered at high temperatures, "RoHS" products are suitable for use in specified lead-free processes. TI may reference these types of products as "Pb-Free".

**RoHS Exempt:** TI defines "RoHS Exempt" to mean products that contain lead but are compliant with EU RoHS pursuant to a specific EU RoHS exemption.

**Green:** TI defines "Green" to mean the content of Chlorine (Cl) and Bromine (Br) based flame retardants meet JS709B low halogen requirements of <=1000ppm threshold. Antimony trioxide based flame retardants must also meet the <=1000ppm threshold requirement.

(3) MSL, Peak Temp. - The Moisture Sensitivity Level rating according to the JEDEC industry standard classifications, and peak solder temperature.

(4) There may be additional marking, which relates to the logo, the lot trace code information, or the environmental category on the device.

(5) Multiple Device Markings will be inside parentheses. Only one Device Marking contained in parentheses and separated by a "~" will appear on a device. If a line is indented then it is a continuation of the previous line and the two combined represent the entire Device Marking for that device.

(6) Lead finish/Ball material - Orderable Devices may have multiple material finish options. Finish options are separated by a vertical ruled line. Lead finish/Ball material values may wrap to two lines if the finish value exceeds the maximum column width.

**Important Information and Disclaimer:**The information provided on this page represents TI's knowledge and belief as of the date that it is provided. TI bases its knowledge and belief on information provided by third parties, and makes no representation or warranty as to the accuracy of such information. Efforts are underway to better integrate information from third parties. TI has taken and continues to take reasonable steps to provide representative and accurate information but may not have conducted destructive testing or chemical analysis on incoming materials and chemicals. TI and TI suppliers consider certain information to be proprietary, and thus CAS numbers and other limited information may not be available for release.

In no event shall TI's liability arising out of such information exceed the total purchase price of the TI part(s) at issue in this document sold by TI to Customer on an annual basis.



**TAPE AND REEL INFORMATION**

**QUADRANT ASSIGNMENTS FOR PIN 1 ORIENTATION IN TAPE**

\*All dimensions are nominal

Device	Package Type	Package Drawing	Pins	SPQ	Reel Diameter (mm)	Reel Width W1 (mm)	A0 (mm)	B0 (mm)	K0 (mm)	P1 (mm)	W (mm)	Pin1 Quadrant
TPS56221DQPR	LSON-CLIP	DQP	22	2500	330.0	12.4	5.3	6.3	1.8	8.0	12.0	Q1
TPS56221DQPT	LSON-CLIP	DQP	22	250	180.0	12.4	5.3	6.3	1.8	8.0	12.0	Q1

**TAPE AND REEL BOX DIMENSIONS**

\*All dimensions are nominal

Device	Package Type	Package Drawing	Pins	SPQ	Length (mm)	Width (mm)	Height (mm)
TPS56221DQPR	LSON-CLIP	DQP	22	2500	367.0	367.0	35.0
TPS56221DQPT	LSON-CLIP	DQP	22	250	210.0	185.0	35.0

DQP (R-PSON-N22)

PLASTIC SMALL OUTLINE NO-LEAD

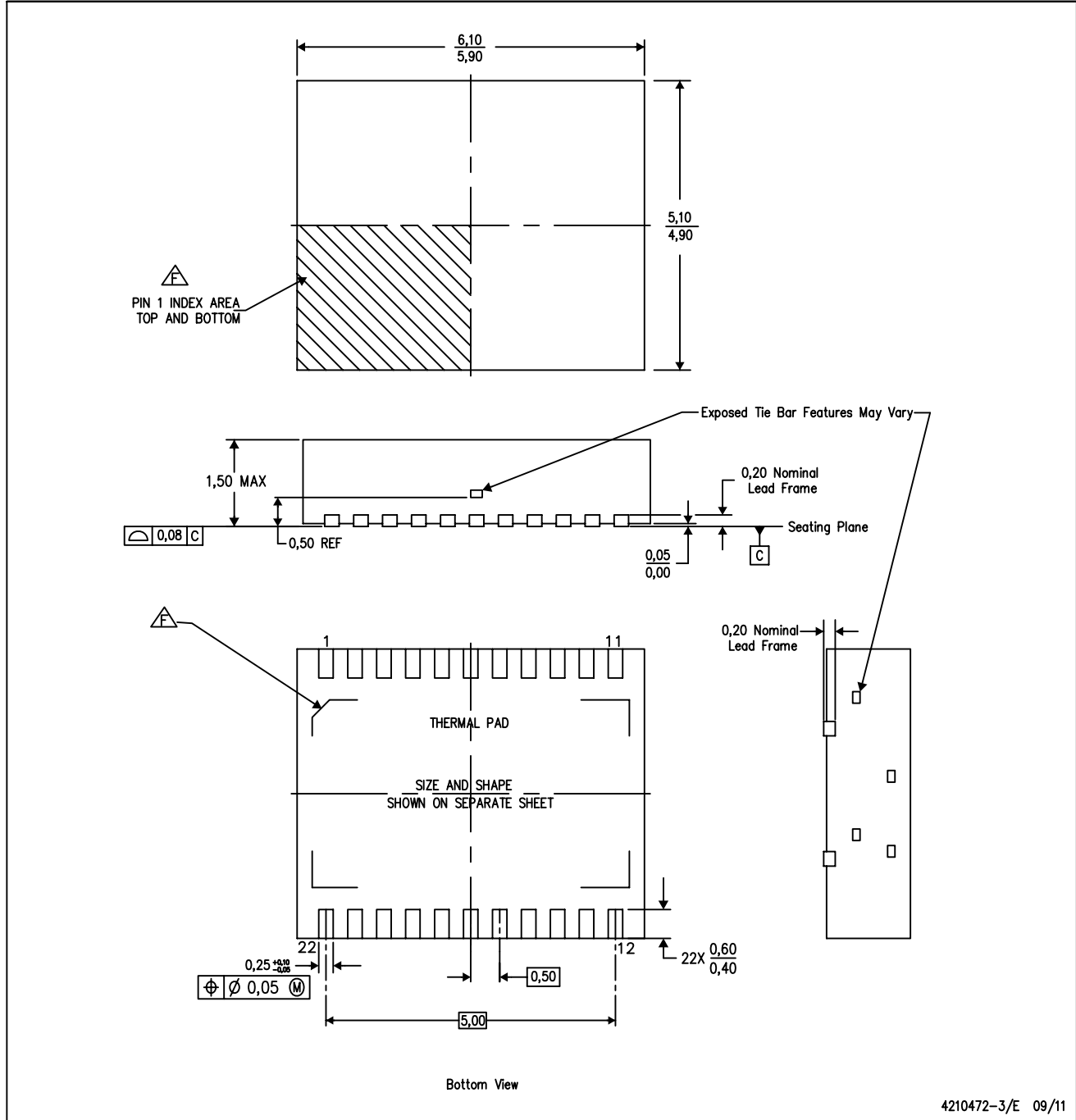

- NOTES:
- A. All linear dimensions are in millimeters. Dimensioning and tolerancing per ASME Y14.5M-1994.
  - B. This drawing is subject to change without notice.
  - C. Small Outline No-Lead (SON) package configuration.
  - D. The package thermal pad must be soldered to the board for thermal and mechanical performance.
  - E. See the additional figure in the Product Data Sheet for details regarding the exposed thermal pad features and dimensions.
  - F. Pin 1 identifiers are located on both top and bottom of the package and within the zone indicated. The Pin 1 identifiers are either a molded, marked, or metal feature.

# THERMAL PAD MECHANICAL DATA

DQP (R-PSO-N22)

PLASTIC SMALL OUTLINE NO-LEAD

## THERMAL INFORMATION

This package incorporates an exposed thermal pad that is designed to be attached directly to an external heatsink. The thermal pad must be soldered directly to the printed circuit board (PCB). After soldering, the PCB can be used as a heatsink. In addition, through the use of thermal vias, the thermal pad can be attached directly to the appropriate copper plane shown in the electrical schematic for the device, or alternatively, can be attached to a special heatsink structure designed into the PCB. This design optimizes the heat transfer from the integrated circuit (IC).

For information on the Quad Flatpack No-Lead (QFN) package and its advantages, refer to Application Report, QFN/SO-N PCB Attachment, Texas Instruments Literature No. SLUA271. This document is available at [www.ti.com](http://www.ti.com).

The exposed thermal pad dimensions for this package are shown in the following illustration.

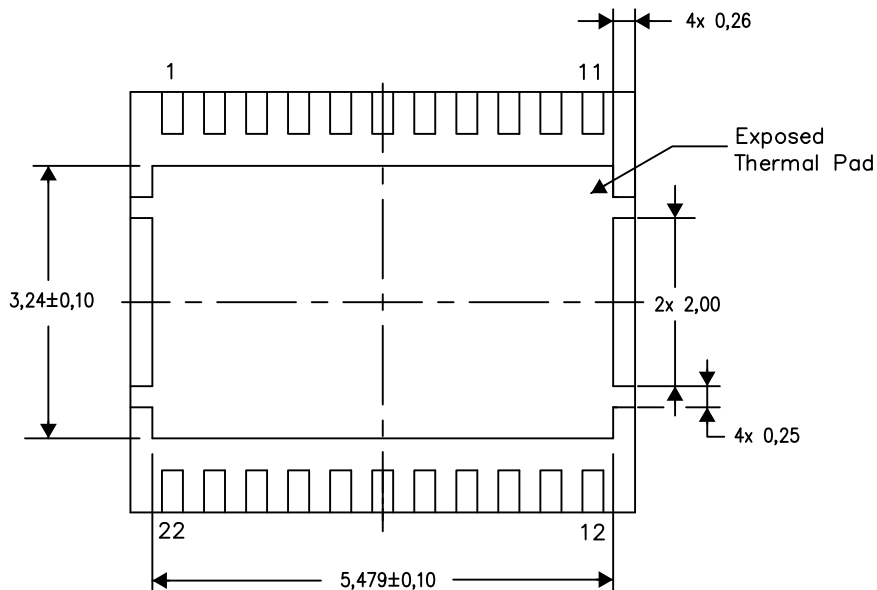

Bottom View

Exposed Thermal Pad Dimensions

4211024-3/H 08/15

NOTE: All linear dimensions are in millimeters

DQP (R-PSO-N22)

PLASTIC SMALL OUTLINE NO-LEAD

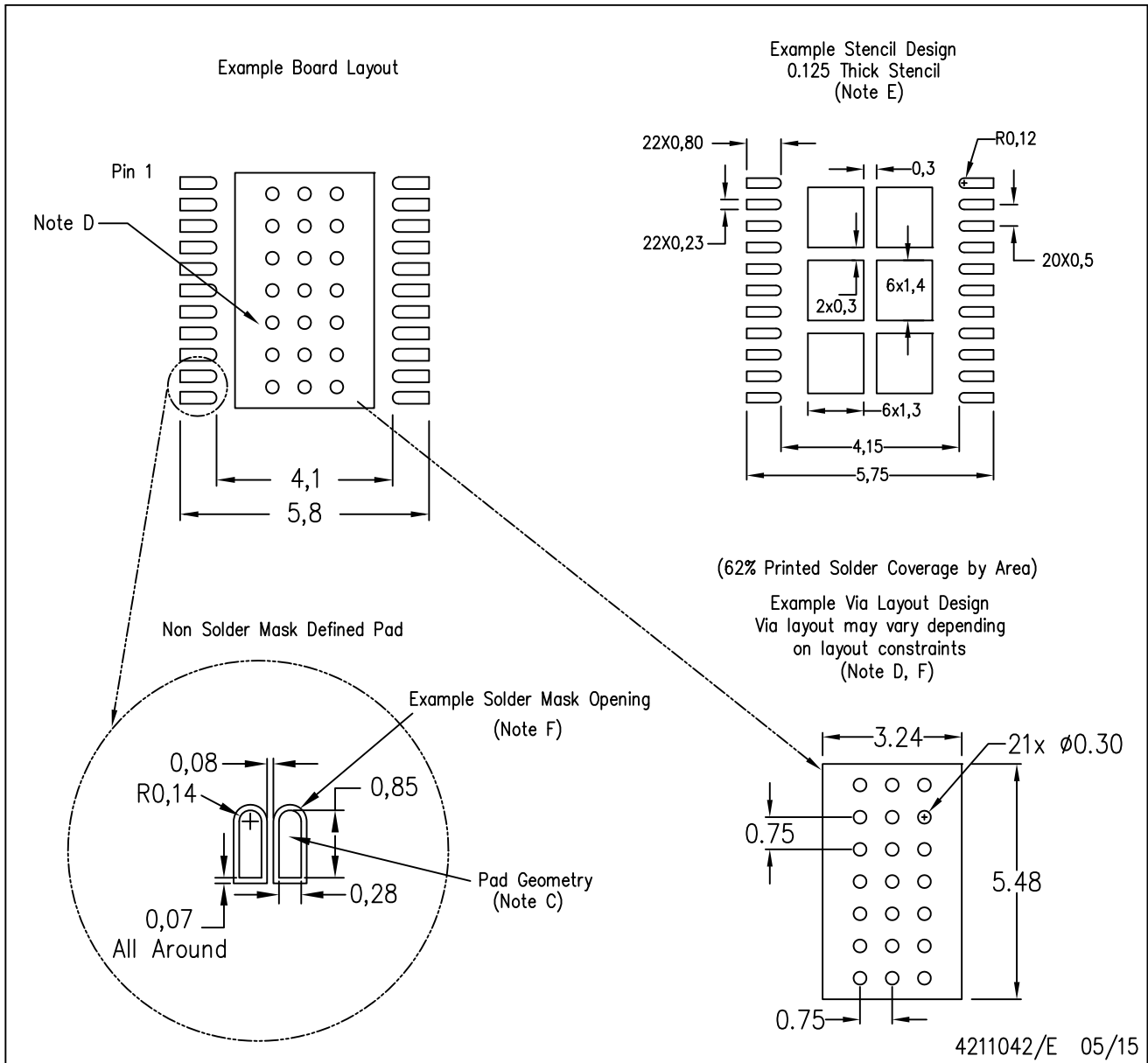

- NOTES:
- All linear dimensions are in millimeters.
  - This drawing is subject to change without notice.
  - Publication IPC-7351 is recommended for alternate designs.
  - This package is designed to be soldered to a thermal pad on the board. Refer to Application Note, QFN/SON PCB Attachment, Texas Instruments Literature No. SLUA271, and also the Product Data Sheets for specific thermal information, via requirements, and recommended board layout. These documents are available at [www.ti.com](http://www.ti.com) <<http://www.ti.com>>.
  - Laser cutting apertures with trapezoidal walls and also rounding corners will offer better paste release. Customers should contact their board assembly site for stencil design recommendations. Refer to IPC 7525 for stencil design considerations.
  - Customers should contact their board fabrication site for recommended solder mask tolerances and via tenting recommendations for vias placed in the thermal pad.

## 重要声明和免责声明

TI“按原样”提供技术和可靠性数据（包括数据表）、设计资源（包括参考设计）、应用或其他设计建议、网络工具、安全信息和其他资源，不保证没有瑕疵且不做任何明示或暗示的担保，包括但不限于对适销性、某特定用途方面的适用性或不侵犯任何第三方知识产权的暗示担保。

这些资源可供使用 TI 产品进行设计的熟练开发人员使用。您将自行承担以下全部责任：(1) 针对您的应用选择合适的 TI 产品，(2) 设计、验证并测试您的应用，(3) 确保您的应用满足相应标准以及任何其他功能安全、信息安全、监管或其他要求。

这些资源如有变更，恕不另行通知。TI 授权您仅可将这些资源用于研发本资源所述的 TI 产品的应用。严禁对这些资源进行其他复制或展示。您无权使用任何其他 TI 知识产权或任何第三方知识产权。您应全额赔偿因在这些资源的使用中对 TI 及其代表造成的任何索赔、损害、成本、损失和债务，TI 对此概不负责。

TI 提供的产品受 [TI 的销售条款](#) 或 [ti.com](#) 上其他适用条款/TI 产品随附的其他适用条款的约束。TI 提供这些资源并不会扩展或以其他方式更改 TI 针对 TI 产品发布的适用的担保或担保免责声明。

TI 反对并拒绝您可能提出的任何其他或不同的条款。

邮寄地址：Texas Instruments, Post Office Box 655303, Dallas, Texas 75265  
Copyright © 2021，德州仪器 (TI) 公司