

## DRV5013-Q1 汽车类数字锁存霍尔效应传感器

### 1 特性

- 符合面向汽车应用的 AEC-Q100 标准：
  - 器件 HBM ESD 分类等级 2
  - 器件 CDM ESD 分类等级 C4B
  - 1 级： $T_A = -40^{\circ}\text{C}$  至  $125^{\circ}\text{C}$  (Q, 请参阅 [器件命名规则](#))
  - 0 级： $T_A = -40^{\circ}\text{C}$  至  $150^{\circ}\text{C}$  (E, 请参阅 [器件命名规则](#))
- 数字双极锁存霍尔传感器
- 出色的温度稳定性
  - 在温度范围内  $B_{OP} \pm 10\%$
- 多种灵敏度选项 ( $B_{OP}/B_{RP}$ )
  - 1.3/-1.3mT (FA, 请参阅 [器件命名规则](#))
  - 2.7/-2.7mT (AD, 请参阅 [器件命名规则](#))
  - 6/-6mT (AG, 请参阅 [器件命名规则](#))
  - 12/-12mT (BC, 请参阅 [器件命名规则](#))
- 支持宽电压范围
  - 2.7V 至 38V
  - 无需外部稳压器
- 开漏输出 (30mA 灌电流)
- 35 $\mu\text{s}$  短暂上电时间
- 小型封装尺寸
  - 表面贴装 3 引脚小外形尺寸晶体管 (SOT)-23 (DBZ)
    - 2.92mm x 2.37mm
  - 插入式 3 引脚 TO-92 (LPG)
    - 4.00mm x 3.15mm
- 保护特性
  - 反向电源保护 (高达 -22V)
  - 支持高达 40V 抛负载
  - 输出短路保护
  - 输出电流限制
  - 电池输出短路保护

### 2 应用

- 电动工具
- 流量计
- 阀门和螺线管状态
- 无刷直流电机
- 接近感测
- 转速计

### 3 说明

DRV5013-Q1 器件是一款斩波稳定霍尔效应传感器，能够在整个温度范围内提供具有出色灵敏度稳定性和集成保护特性的磁场感测特性。

磁场由数字双极锁存输出表示。该集成电路 (IC) 配有一个灌电流能力达 30mA 的漏极开路输出级。反向极性保护高达 -22V 的宽工作电压范围 (2.7 至 38V) 使得此器件广泛适用于各种汽车应用。

提供针对反向电源情况、抛负载和输出短路或者过流的内部保护功能。

器件信息<sup>(1)</sup>

器件型号	封装	封装尺寸 (标称值)
DRV5013-Q1	SOT-23 (3)	2.92mm x 1.30mm
	TO-92 (3)	4.00mm x 3.15mm

(1) 如需了解所有可用封装，请参阅数据表末尾的封装选项附录。

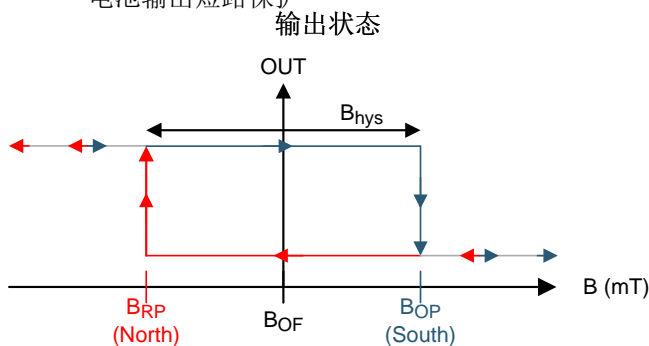

器件封装

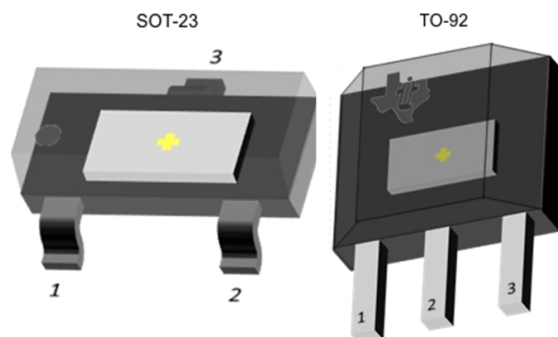

## 目录

1	特性 .....	1	7.3	Feature Description .....	11
2	应用 .....	1	7.4	Device Functional Modes .....	16
3	说明 .....	1	<b>8</b>	<b>Application and Implementation .....</b>	<b>17</b>
4	修订历史记录 .....	2	8.1	Application Information .....	17
5	<b>Pin Configuration and Functions .....</b>	<b>4</b>	8.2	Typical Applications .....	17
6	<b>Specifications .....</b>	<b>5</b>	<b>9</b>	<b>Power Supply Recommendations .....</b>	<b>19</b>
6.1	Absolute Maximum Ratings .....	5	<b>10</b>	<b>Layout .....</b>	<b>20</b>
6.2	ESD Ratings .....	5	10.1	Layout Guidelines .....	20
6.3	Recommended Operating Conditions .....	5	10.2	Layout Example .....	20
6.4	Thermal Information .....	5	<b>11</b>	<b>器件和文档支持 .....</b>	<b>21</b>
6.5	Electrical Characteristics .....	6	11.1	器件支持 .....	21
6.6	Switching Characteristics .....	6	11.2	接收文档更新通知 .....	21
6.7	Magnetic Characteristics .....	7	11.3	社区资源 .....	22
6.8	Typical Characteristics .....	8	11.4	商标 .....	22
<b>7</b>	<b>Detailed Description .....</b>	<b>10</b>	11.5	静电放电警告 .....	22
7.1	Overview .....	10	11.6	术语表 .....	22
7.2	Functional Block Diagram .....	10	<b>12</b>	<b>机械、封装和可订购信息 .....</b>	<b>22</b>

## 4 修订历史记录

注：之前版本的页码可能与当前版本有所不同。

Changes from Revision G (October 2017) to Revision H	Page
• Changed <i>Power Supply Recommendations</i> section .....	19

Changes from Revision F (September 2016) to Revision G	Page
• 已更改 将特定于汽车的 特性 项目符号位置更改到了 特性 部分顶部 .....	1
• 已添加 向特定于汽车的 特性特性项目符号中添加了器件 HBM 和 CDM 分类子项目符号 .....	1
• Added last sentence to <i>Device Functional Modes</i> section .....	16

Changes from Revision E (August 2016) to Revision F	Page
• Made changes to the Power-on time in the <i>Electrical Characteristics</i> table .....	6

Changes from Revision D (June 2016) to Revision E	Page
• Revised preliminary limits for FA version in the <i>Magnetic Characteristics</i> table .....	7
• Added the <i>Layout</i> section .....	20

Changes from Revision C (May 2016) to Revision D	Page
• Revised preliminary limits for the FA version .....	7

Changes from Revision B (February 2016) to Revision C	Page
• Revised preliminary limits for the FA version .....	7

<b>Changes from Revision A (December 2015) to Revision B</b>	<b>Page</b>
• 已添加 FA 器件选项 .....	1
• Added the typical bandwidth value to the <i>Magnetic Characteristics</i> table .....	7

---

<b>Changes from Original (December 2014) to Revision A</b>	<b>Page</b>
• 已更正 SOT-23 封装体尺寸并将 SIP 封装名称更正为 TO-92 .....	1
• Added $B_{MAX}$ to <i>Absolute Maximum Ratings</i> .....	5
• Removed table notes regarding testing for the operating junction temperature in <i>Absolute Maximum Ratings</i> .....	5
• 已更新封装卷带选项 M 和空白 .....	21
• 已添加 <a href="#">社区资源</a> .....	22

---

## 5 Pin Configuration and Functions

For additional configuration information, see [器件标记](#) and [机械、封装和可订购信息](#).

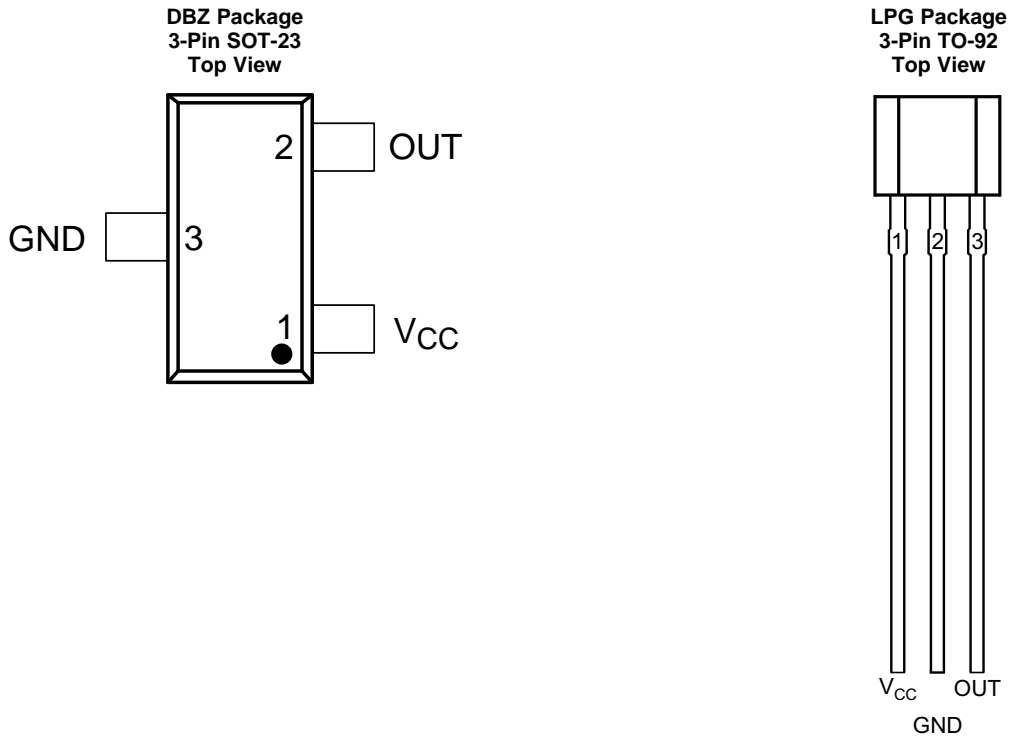

**Pin Functions**

PIN			TYPE	DESCRIPTION
NAME	DBZ	LPG		
GND	3	2	GND	Ground pin
OUT	2	3	Output	Hall sensor open-drain output. The open drain requires a resistor pullup.
V <sub>CC</sub>	1	1	PWR	2.7 to 38 V power supply. Bypass this pin to the GND pin with a 0.01- $\mu$ F (minimum) ceramic capacitor rated for V <sub>CC</sub> .

## 6 Specifications

### 6.1 Absolute Maximum Ratings

over operating free-air temperature range (unless otherwise noted) <sup>(1)</sup>

		MIN	MAX	UNIT
Power supply voltage	V <sub>CC</sub>	-22 <sup>(2)</sup>	40	V
	Voltage ramp rate (V <sub>CC</sub> ), V <sub>CC</sub> < 5 V	Unlimited		V/μs
	Voltage ramp rate (V <sub>CC</sub> ), V <sub>CC</sub> > 5 V	0	2	
Output pin voltage		-0.5	40	V
Output pin reverse current during reverse supply condition		0	100	mA
Magnetic flux density, B <sub>MAX</sub>		Unlimited		
Operating junction temperature, T <sub>J</sub>	Q, see <a href="#">图 24</a>	-40	150	°C
	E, see <a href="#">图 24</a>	-40	175	
Storage temperature, T <sub>stg</sub>		-65	150	°C

- (1) Stresses beyond those listed under *Absolute Maximum Ratings* may cause permanent damage to the device. These are stress ratings only, which do not imply functional operation of the device at these or any other conditions beyond those indicated under *Recommended Operating Conditions*. Exposure to absolute-maximum-rated conditions for extended periods may affect device reliability.
- (2) Ensured by design. Only tested to -20 V.

### 6.2 ESD Ratings

		VALUE	UNIT
V <sub>(ESD)</sub> Electrostatic discharge	Human-body model (HBM), per AEC Q100-002 <sup>(1)</sup>	±2500	V
	Charged-device model (CDM), per AEC Q100-011	±500	

- (1) AEC Q100-002 indicates that HBM stressing shall be in accordance with the ANSI/ESDA/JEDEC JS-001 specification.

### 6.3 Recommended Operating Conditions

over operating free-air temperature range (unless otherwise noted)

		MIN	MAX	UNIT	
V <sub>CC</sub>	Power supply voltage	2.7	38	V	
V <sub>O</sub>	Output pin voltage (OUT)	0	38	V	
I <sub>SINK</sub>	Output pin current sink (OUT) <sup>(1)</sup>	0	30	mA	
T <sub>A</sub>	Operating ambient temperature	Q, see <a href="#">图 24</a>	-40	125	°C
		E, see <a href="#">图 24</a>	-40	150	

- (1) Power dissipation and thermal limits must be observed

### 6.4 Thermal Information

THERMAL METRIC <sup>(1)</sup>	DRV5013-Q1		UNIT	
	DBZ (SOT-23)	LPG (TO-92)		
	3 PINS	3 PINS		
R <sub>θJA</sub>	Junction-to-ambient thermal resistance	333.2	180	°C/W
R <sub>θJC(top)</sub>	Junction-to-case (top) thermal resistance	99.9	98.6	°C/W
R <sub>θJB</sub>	Junction-to-board thermal resistance	66.9	154.9	°C/W
ψ <sub>JT</sub>	Junction-to-top characterization parameter	4.9	40	°C/W
ψ <sub>JB</sub>	Junction-to-board characterization parameter	65.2	154.9	°C/W

- (1) For more information about traditional and new thermal metrics, see the [Semiconductor and IC Package Thermal Metrics](#) application report.

## 6.5 Electrical Characteristics

over operating free-air temperature range (unless otherwise noted)

PARAMETER		TEST CONDITIONS	MIN	TYP	MAX	UNIT
<b>POWER SUPPLIES (V<sub>CC</sub>)</b>						
V <sub>CC</sub>	V <sub>CC</sub> operating voltage		2.7		38	V
I <sub>CC</sub>	Operating supply current	V <sub>CC</sub> = 2.7 to 38 V, T <sub>A</sub> = 25°C		2.7		mA
		V <sub>CC</sub> = 2.7 to 38 V, T <sub>A</sub> = T <sub>A, MAX</sub> <sup>(1)</sup>		3	3.5	
t <sub>on</sub>	Power-on time	AD, AG, BC versions		35	50	μs
		FA version		35	70	
<b>OPEN DRAIN OUTPUT (OUT)</b>						
r <sub>DS(on)</sub>	FET on-resistance	V <sub>CC</sub> = 3.3 V, I <sub>O</sub> = 10 mA, T <sub>A</sub> = 25°C		22		Ω
		V <sub>CC</sub> = 3.3 V, I <sub>O</sub> = 10 mA, T <sub>A</sub> = 125°C		36	50	
I <sub>lkg(off)</sub>	Off-state leakage current	Output Hi-Z			1	μA
<b>PROTECTION CIRCUITS</b>						
V <sub>CCR</sub>	Reverse supply voltage		-22			V
I <sub>OCF</sub>	Overcurrent protection level	OUT shorted V <sub>CC</sub>	15	30	45	mA

 (1) T<sub>A, MAX</sub> is 125°C for Q Grade 1 devices and 150°C for E Grade 0 devices (see [Fig 24](#))

## 6.6 Switching Characteristics

over operating free-air temperature range (unless otherwise noted)

PARAMETER		TEST CONDITIONS	MIN	TYP	MAX	UNIT
<b>OPEN DRAIN OUTPUT (OUT)</b>						
t <sub>d</sub>	Output delay time	B = B <sub>RP</sub> - 10 mT to B <sub>OP</sub> + 10 mT in 1 μs		13	25	μs
t <sub>r</sub>	Output rise time (10% to 90%)	R1 = 1 kΩ, C <sub>O</sub> = 50 pF, V <sub>CC</sub> = 3.3 V		200		ns
t <sub>f</sub>	Output fall time (90% to 10%)	R1 = 1 kΩ, C <sub>O</sub> = 50 pF, V <sub>CC</sub> = 3.3 V		31		ns

## 6.7 Magnetic Characteristics

over operating free-air temperature range (unless otherwise noted)

PARAMETER		TEST CONDITIONS	MIN	TYP	MAX	UNIT <sup>(1)</sup>
$f_{BW}$	Bandwidth <sup>(2)</sup>		20	30		kHz
<b>DRV5013FA: 1.3 / -1.3 mT</b>						
$B_{OP}$	Operate point; see <a href="#">Figure 12</a>		-0.6	1.3	3.4	mT
$B_{RP}$	Release point; see <a href="#">Figure 12</a>		-3.4	-1.3	0.6	mT
$B_{hys}$	Hysteresis; $B_{hys} = (B_{OP} - B_{RP})$		1.2	2.6		mT
$B_O$	Magnetic offset; $B_O = (B_{OP} + B_{RP}) / 2$		-1.5	0	1.5	mT
<b>DRV5013AD: 2.7 / -2.7 mT</b>						
$B_{OP}$	Operate point; see <a href="#">Figure 12</a>		1	2.7	5	mT
$B_{RP}$	Release point; see <a href="#">Figure 12</a>		-5	-2.7	-1	mT
$B_{hys}$	Hysteresis; $B_{hys} = (B_{OP} - B_{RP})$			5.4		mT
$B_O$	Magnetic offset; $B_O = (B_{OP} + B_{RP}) / 2$		-1.5	0	1.5	mT
<b>DRV5013AG: 6 / -6 mT</b>						
$B_{OP}$	Operate point; see <a href="#">Figure 12</a>		3	6	9	mT
$B_{RP}$	Release point; see <a href="#">Figure 12</a>		-9	-6	-3	mT
$B_{hys}$	Hysteresis; $B_{hys} = (B_{OP} - B_{RP})$			12		mT
$B_O$	Magnetic offset; $B_O = (B_{OP} + B_{RP}) / 2$		-1.5	0	1.5	mT
<b>DRV5013BC: 12 / -12 mT</b>						
$B_{OP}$	Operate point; see <a href="#">Figure 12</a>		6	12	18	mT
$B_{RP}$	Release point; see <a href="#">Figure 12</a>		-18	-12	-6	mT
$B_{hys}$	Hysteresis; $B_{hys} = (B_{OP} - B_{RP})$			24		mT
$B_O$	Magnetic offset; $B_O = (B_{OP} + B_{RP}) / 2$		-1.5	0	1.5	mT

(1) 1 mT = 10 Gauss

(2) Bandwidth describes the fastest changing magnetic field that can be detected and translated to the output.

### 6.8 Typical Characteristics

$T_A > 125^\circ\text{C}$  data is valid for Grade 0 devices only (E, see [Figure 24](#))

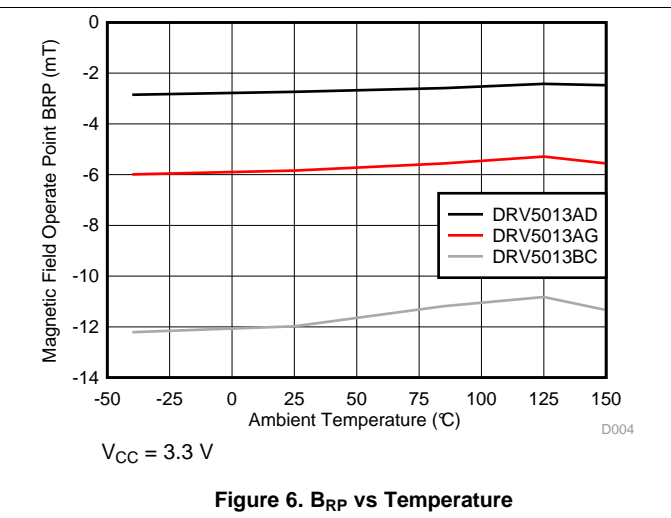
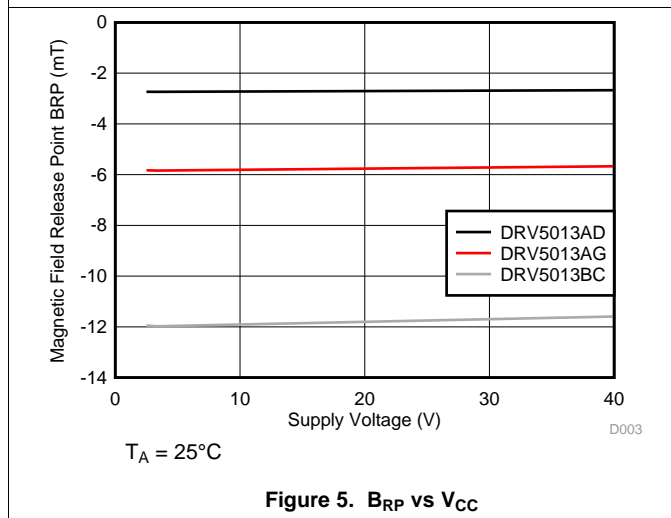
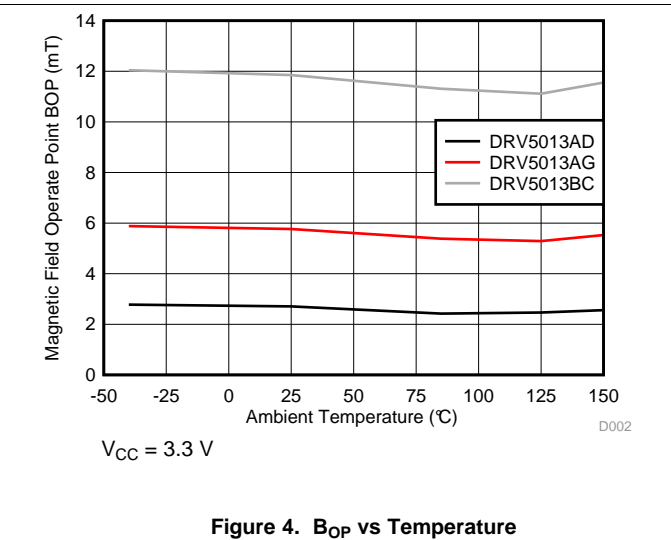
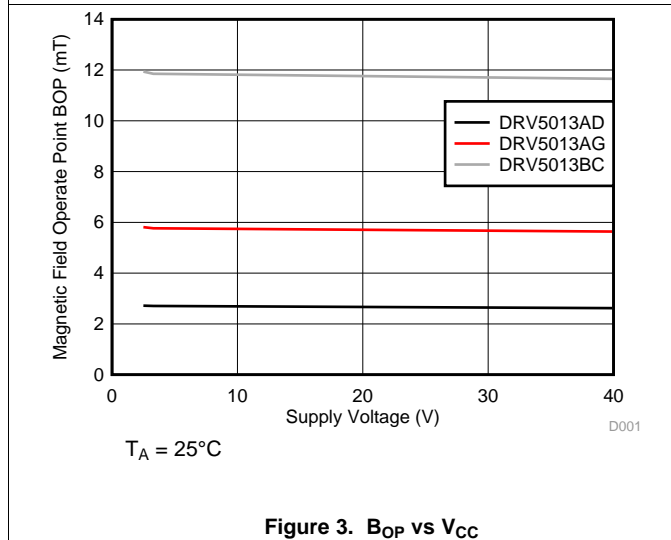
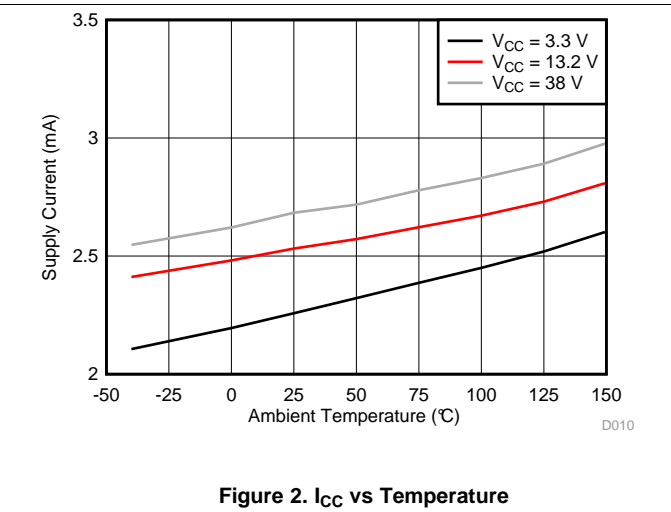
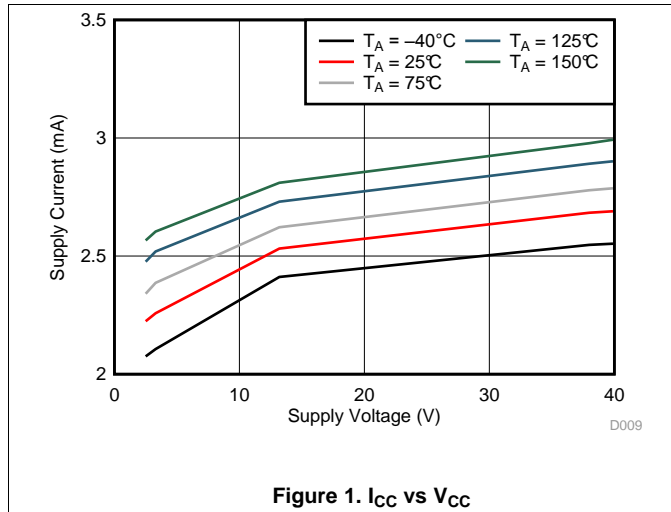

Typical Characteristics (continued)

$T_A > 125^\circ\text{C}$  data is valid for Grade 0 devices only (E, see 图 24)

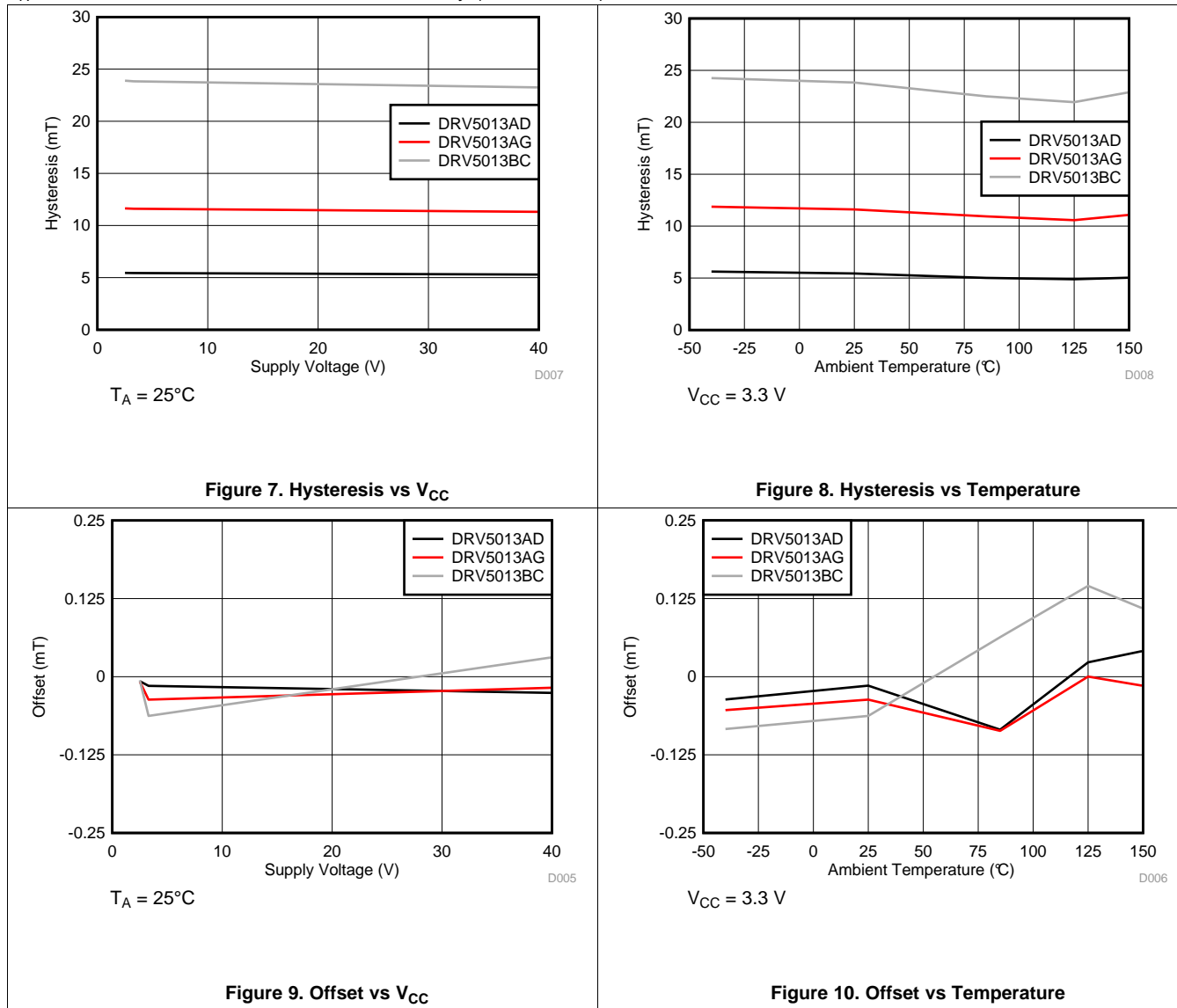

## 7 Detailed Description

### 7.1 Overview

The DRV5013-Q1 device is a chopper-stabilized Hall sensor with a digital latched output for magnetic sensing applications. The DRV5013-Q1 device can be powered with a supply voltage between 2.7 and 38 V, and continuously survives continuous  $-22\text{-V}$  reverse-battery conditions. The DRV5013-Q1 device does not operate when  $-22$  to  $2.4\text{ V}$  is applied to the  $V_{CC}$  pin (with respect to the GND pin). In addition, the device can withstand voltages up to  $40\text{ V}$  for transient durations.

The field polarity is defined as follows: a **south pole** near the marked side of the package is a positive magnetic field. A **north pole** near the marked side of the package is a negative magnetic field.

The output state is dependent on the magnetic field perpendicular to the package. A **south pole** near the marked side of the package causes the output to pull low (operate point,  $B_{OP}$ ), and a **north pole** near the marked side of the package causes the output to release (release point,  $B_{RP}$ ). Hysteresis is included in between the operate point and the release point therefore magnetic-field noise does not accidentally trip the output.

An external pullup resistor is required on the OUT pin. The OUT pin can be pulled up to  $V_{CC}$ , or to a different voltage supply. This allows for easier interfacing with controller circuits.

### 7.2 Functional Block Diagram

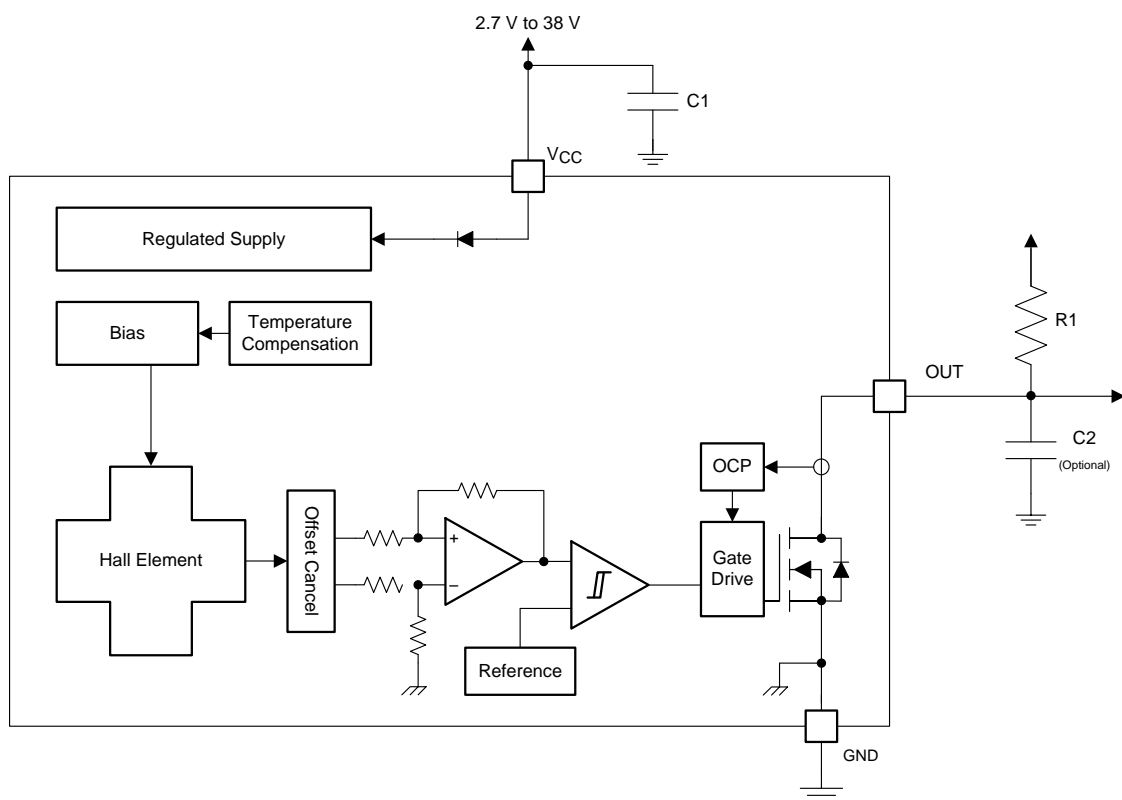

Copyright © 2017, Texas Instruments Incorporated

### 7.3 Feature Description

#### 7.3.1 Field Direction Definition

A positive magnetic field is defined as a **south pole** near the marked side of the package as shown in [Figure 11](#).

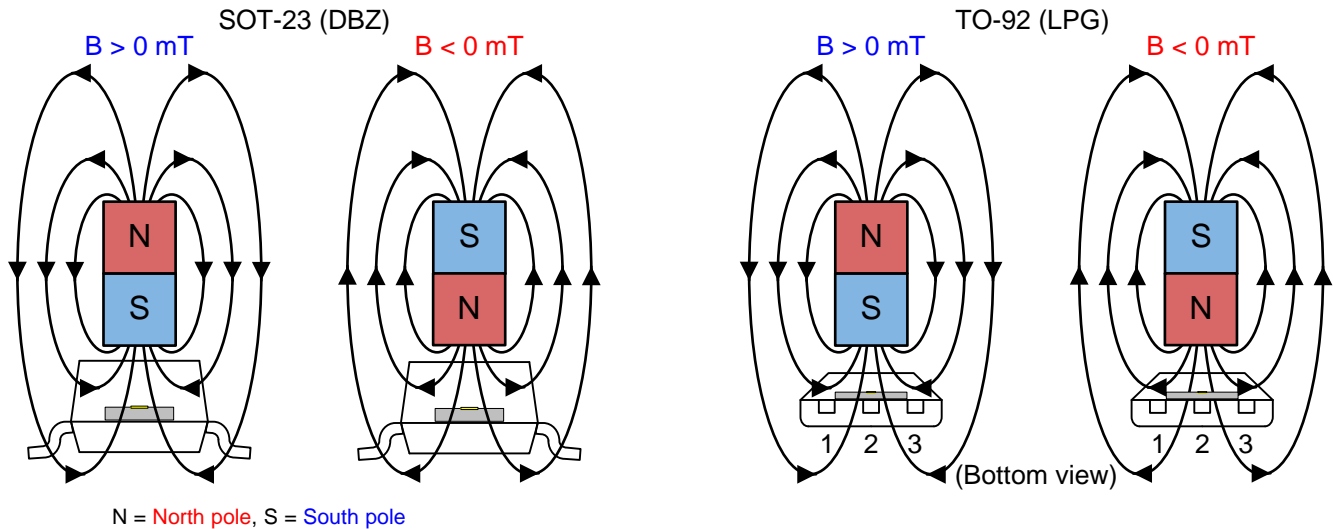

Figure 11. Field Direction Definition

#### 7.3.2 Device Output

If the device is powered on with a magnetic field strength between  $B_{RP}$  and  $B_{OP}$ , then the device output is indeterminate and can either be Hi-Z or Low. If the field strength is greater than  $B_{OP}$ , then the output is pulled low. If the field strength is less than  $B_{RP}$ , then the output is released.

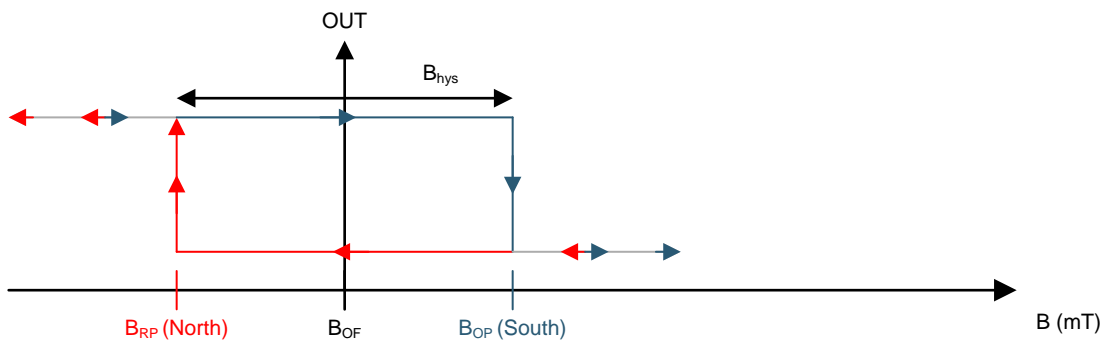
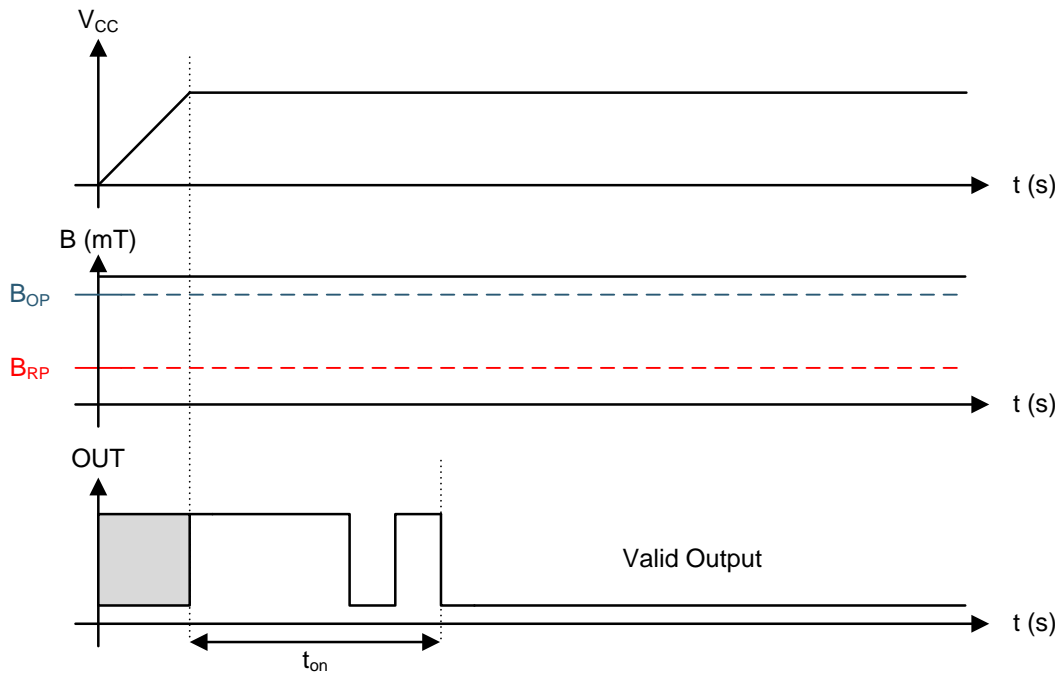

Figure 12. DRV5013-Q1— $B_{OP} > 0$

## Feature Description (continued)

### 7.3.3 Power-On Time

After applying  $V_{CC}$  to the DRV5013-Q1 device,  $t_{on}$  must elapse before the OUT pin is valid. During the power-up sequence, the output is Hi-Z. A pulse as shown in Figure 13 and Figure 14 occurs at the end of  $t_{on}$ . This pulse can allow the host processor to determine when the DRV5013-Q1 output is valid after startup. In Case 1 (Figure 13) and Case 2 (Figure 14), the output is defined assuming a constant magnetic field  $B > B_{OP}$  and  $B < B_{RP}$ .



**Figure 13. Case 1: Power On When  $B > B_{OP}$**

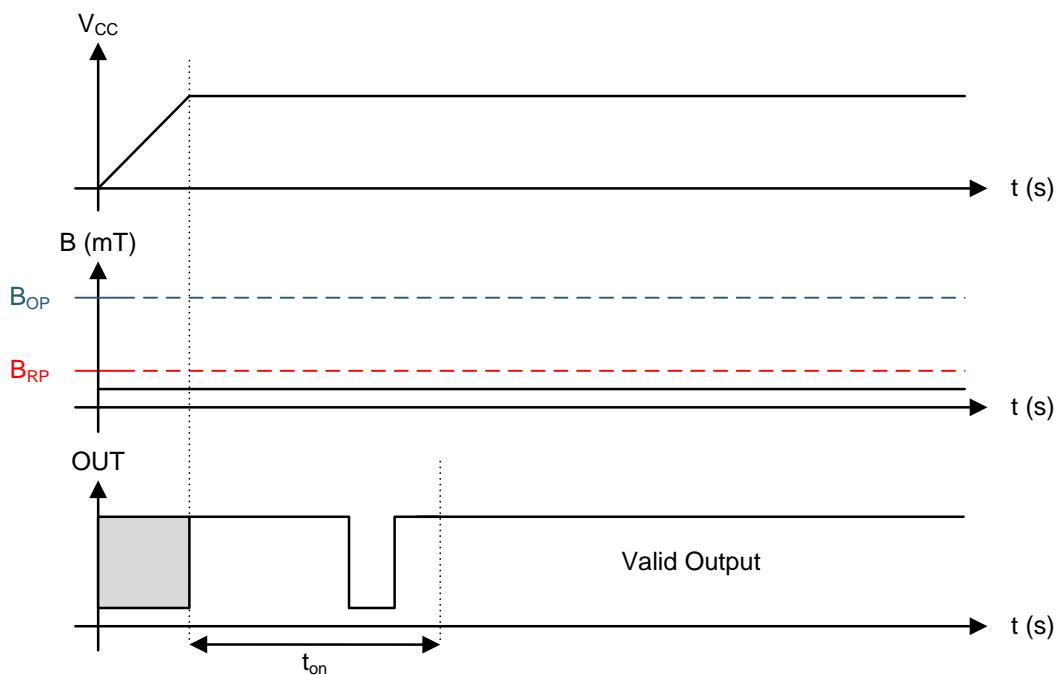

**Figure 14. Case 2: Power On When  $B < B_{RP}$**

### Feature Description (continued)

If the device is powered on with the magnetic field strength  $B_{RP} < B < B_{OP}$ , then the device output is indeterminate and can either be Hi-Z or pulled low. During the power-up sequence, the output is held Hi-Z until  $t_{on}$  has elapsed. At the end of  $t_{on}$ , a pulse is given on the OUT pin to indicate that  $t_{on}$  has elapsed. After  $t_{on}$ , if the magnetic field changes such that  $B_{OP} < B$ , the output is released. Case 3 (Figure 15) and Case 4 (Figure 16) show examples of this behavior.

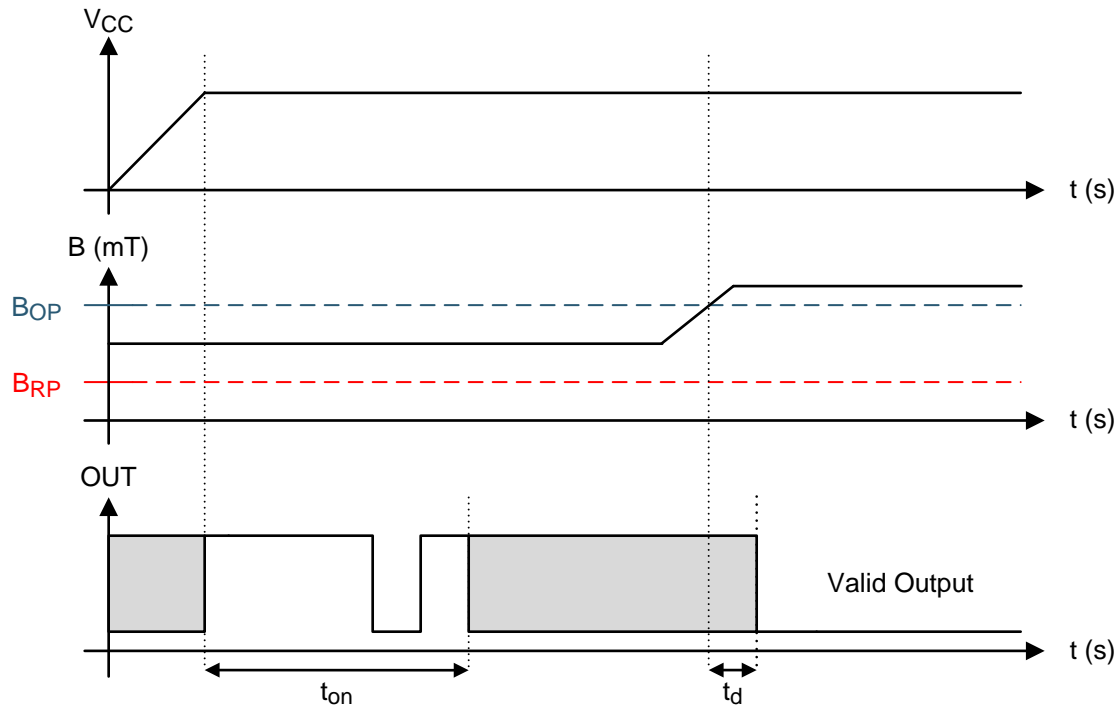
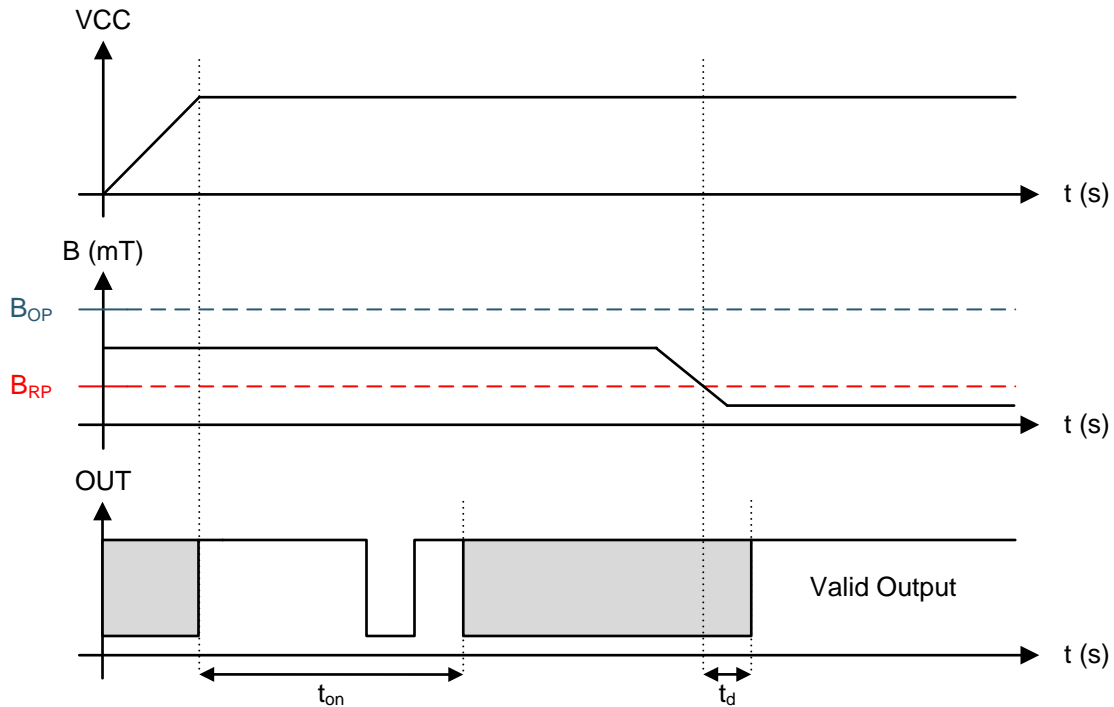

Figure 15. Case 3: Power On When  $B_{RP} < B < B_{OP}$ , Followed by  $B > B_{OP}$

**Feature Description (continued)**

**Figure 16. Case 4: Power On When  $B_{RP} < B < B_{OP}$ , Followed by  $B < B_{RP}$**

**7.3.4 Output Stage**

The DRV5013-Q1 output stage uses an open-drain NMOS, and it is rated to sink up to 30 mA of current. For proper operation, calculate the value of the pullup resistor R1 using [Equation 1](#).

$$\frac{V_{ref \max}}{30 \text{ mA}} \leq R1 \leq \frac{V_{ref \min}}{100 \mu\text{A}} \quad (1)$$

The size of R1 is a tradeoff between the OUT rise time and the current when OUT is pulled low. A lower current is generally better, however faster transitions and bandwidth require a smaller resistor for faster switching.

In addition, ensure that the value of  $R1 > 500 \Omega$  to ensure the output driver can pull the OUT pin close to GND.

---

**NOTE**

$V_{ref}$  is not restricted to  $V_{CC}$ . The allowable voltage range of this pin is specified in the [Absolute Maximum Ratings](#).

---

Feature Description (continued)

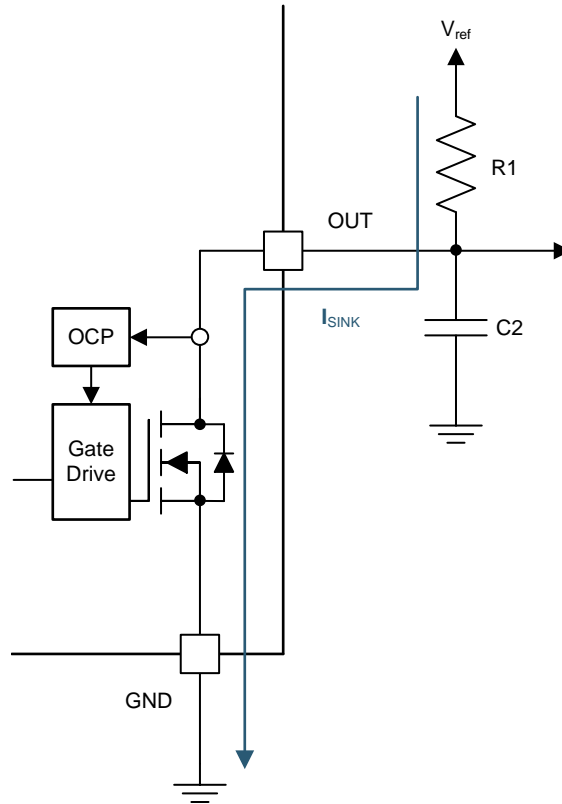

Figure 17.

Select a value for C2 based on the system bandwidth specifications as shown in [Equation 2](#).

$$2 \times f_{BW} \text{ (Hz)} < \frac{1}{2\pi \times R1 \times C2} \tag{2}$$

Most applications do not require this C2 filtering capacitor.

## Feature Description (continued)

### 7.3.5 Protection Circuits

The DRV5013-Q1 device is fully protected against overcurrent and reverse-supply conditions.

### 7.3.6 Overcurrent Protection (OCP)

An analog current-limit circuit limits the current through the FET. The driver current is clamped to  $I_{OCP}$ . During this clamping, the  $r_{DS(on)}$  of the output FET is increased from the nominal value.

### 7.3.7 Load Dump Protection

The DRV5013-Q1 device operates at DC  $V_{CC}$  conditions up to 38 V nominally, and can additionally withstand  $V_{CC} = 40$  V. No current-limiting series resistor is required for this protection.

### 7.3.8 Reverse Supply Protection

The DRV5013-Q1 device is protected in the event that the  $V_{CC}$  pin and the GND pin are reversed (up to  $-22$  V).

#### NOTE

In a reverse supply condition, the OUT pin reverse-current must not exceed the ratings specified in the [Absolute Maximum Ratings](#).

**Table 1.**

FAULT	CONDITION	DEVICE	DESCRIPTION	RECOVERY
FET overload (OCP)	$I_{SINK} \geq I_{OCP}$	Operating	Output current is clamped to $I_{OCP}$	$I_O < I_{OCP}$
Load dump	$38\text{ V} < V_{CC} < 40\text{ V}$	Operating	Device will operate for a transient duration	$V_{CC} \leq 38\text{ V}$
Reverse supply	$-22\text{ V} < V_{CC} < 0\text{ V}$	Disabled	Device will survive this condition	$V_{CC} \geq 2.7\text{ V}$

## 7.4 Device Functional Modes

The DRV5013-Q1 device is active only when  $V_{CC}$  is between 2.7 and 38 V.

When a reverse supply condition exists, the device is inactive. With regard to some industry standards that require analyzing every possible output from a device, an internal clock is unlikely to couple to the output.

## 8 Application and Implementation

### NOTE

Information in the following applications sections is not part of the TI component specification, and TI does not warrant its accuracy or completeness. TI's customers are responsible for determining suitability of components for their purposes. Customers should validate and test their design implementation to confirm system functionality.

### 8.1 Application Information

The DRV5013-Q1 device is used in magnetic-field sensing applications.

### 8.2 Typical Applications

#### 8.2.1 Standard Circuit

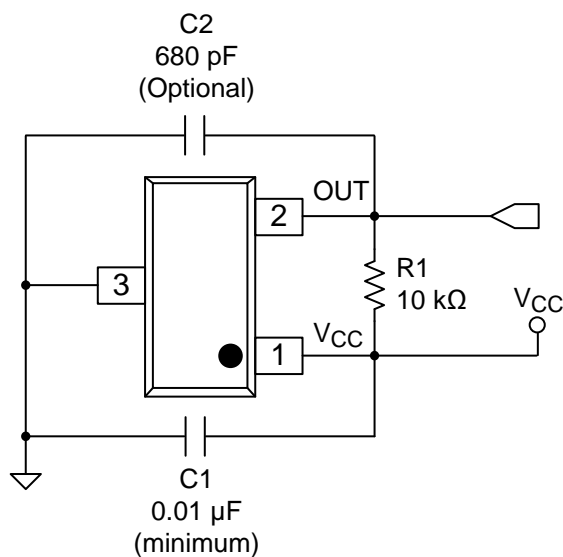

Figure 18. Typical Application Circuit

#### 8.2.1.1 Design Requirements

For this design example, use the parameters listed in Table 2 as the input parameters.

Table 2. Design Parameters

DESIGN PARAMETER	REFERENCE	EXAMPLE VALUE
Supply voltage	$V_{CC}$	3.2 to 3.4 V
System bandwidth	$f_{BW}$	10 kHz

#### 8.2.1.2 Detailed Design Procedure

Table 3. External Components

COMPONENT	PIN 1	PIN 2	RECOMMENDED
C1	$V_{CC}$	GND	A 0.01- $\mu$ F (minimum) ceramic capacitor rated for $V_{CC}$
C2	OUT	GND	<b>Optional:</b> Place a ceramic capacitor to GND
R1	OUT	REF <sup>(1)</sup>	Requires a resistor pullup

(1) REF is not a pin on the DRV5013-Q1 device, but a REF supply-voltage pullup is required for the OUT pin; the OUT pin may be pulled up to  $V_{CC}$ .

**8.2.1.2.1 Configuration Example**

In a 3.3-V system,  $3.2\text{ V} \leq V_{\text{ref}} \leq 3.4\text{ V}$ . Use Equation 3 to calculate the allowable range for R1.

$$\frac{V_{\text{ref max}}}{30\text{ mA}} \leq R1 \leq \frac{V_{\text{ref min}}}{100\text{ }\mu\text{A}} \tag{3}$$

For this design example, use Equation 4 to calculate the allowable range of R1.

$$\frac{3.4\text{ V}}{30\text{ mA}} \leq R1 \leq \frac{3.2\text{ V}}{100\text{ }\mu\text{A}} \tag{4}$$

Therefore:

$$113\text{ }\Omega \leq R1 \leq 32\text{ k}\Omega \tag{5}$$

After finding the allowable range of R1 (Equation 5), select a value between 500  $\Omega$  and 32 k $\Omega$  for R1.

Assuming a system bandwidth of 10 kHz, use Equation 6 to calculate the value of C2.

$$2 \times f_{\text{BW}}\text{ (Hz)} < \frac{1}{2\pi \times R1 \times C2} \tag{6}$$

For this design example, use Equation 7 to calculate the value of C2.

$$2 \times 10\text{ kHz} < \frac{1}{2\pi \times R1 \times C2} \tag{7}$$

An R1 value of 10 k $\Omega$  and a C2 value less than 820 pF satisfy the requirement for a 10-kHz system bandwidth.

A selection of R1 = 10 k $\Omega$  and C2 = 680 pF would cause a low-pass filter with a corner frequency of 23.4 kHz.

**8.2.1.3 Application Curves**

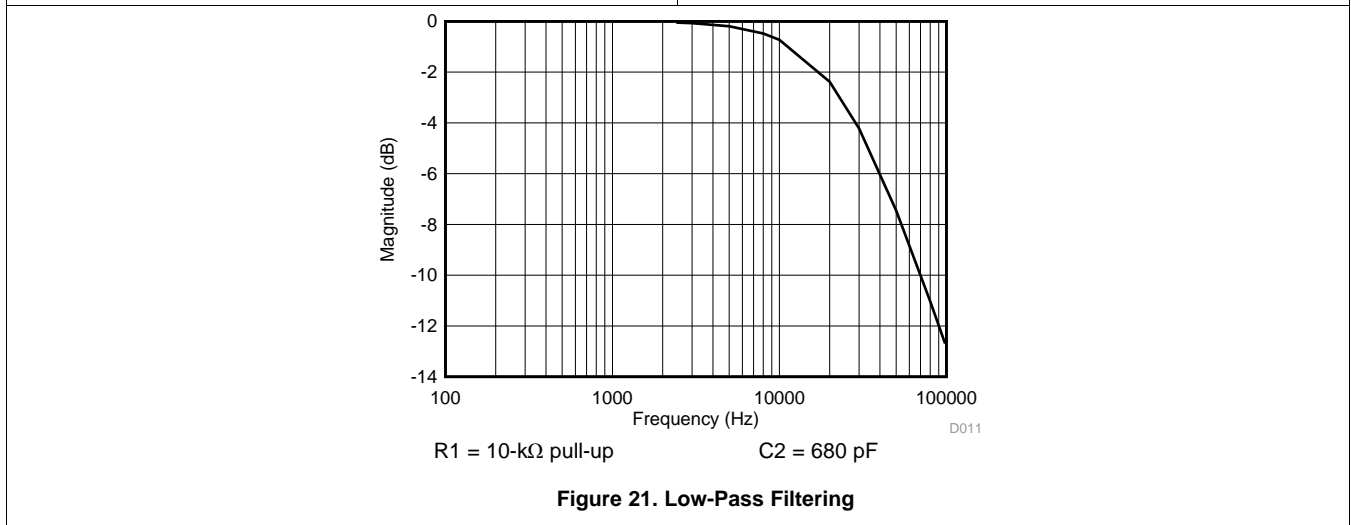
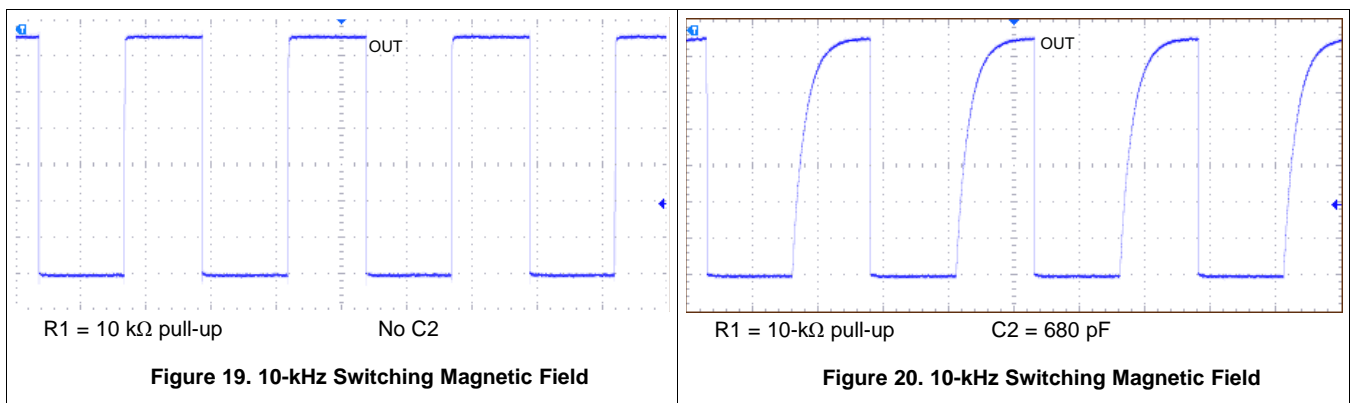

### 8.2.2 Alternative Two-Wire Application

For systems that require minimal wire count, the device output can be connected to  $V_{CC}$  through a resistor, and the total supplied current can be sensed near the controller.

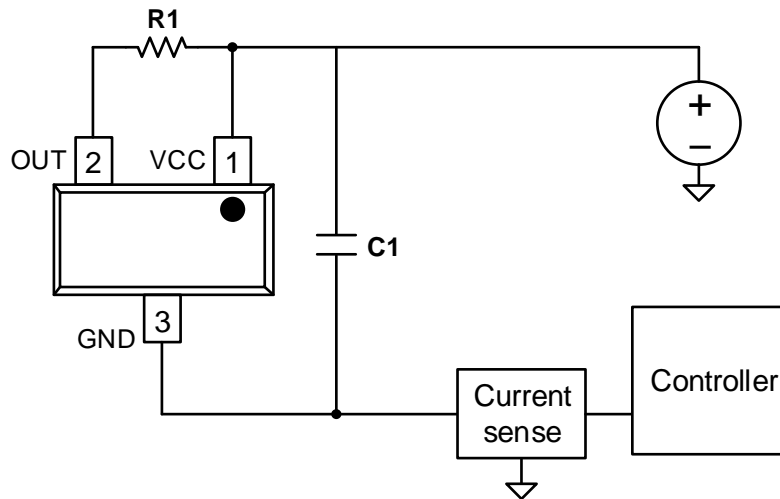

Figure 22. 2-Wire Application

Current can be sensed using a shunt resistor or other circuitry.

#### 8.2.2.1 Design Requirements

Table 4 lists the related design parameters.

Table 4. Design Parameters

DESIGN PARAMETER	REFERENCE	EXAMPLE VALUE
Supply voltage	$V_{CC}$	12 V
OUT resistor	R1	1 k $\Omega$
Bypass capacitor	C1	0.1 $\mu$ F
Current when $B < B_{RP}$	$I_{RELEASE}$	About 3 mA
Current when $B > B_{OP}$	$I_{OPERATE}$	About 15 mA

#### 8.2.2.2 Detailed Design Procedure

When the open-drain output of the device is high-impedance, current through the path equals the  $I_{CC}$  of the device (approximately 3 mA).

When the output pulls low, a parallel current path is added, equal to  $V_{CC} / (R1 + r_{DS(on)})$ . Using 12 V and 1 k $\Omega$ , the parallel current is approximately 12 mA, making the total current approximately 15 mA.

The local bypass capacitor C1 should be at least 0.1  $\mu$ F, and a larger value if there is high inductance in the power line interconnect.

## 9 Power Supply Recommendations

The DRV5013-Q1 device is designed to operate from an input voltage supply ( $V_M$ ) range between 2.7 V and 38 V. A 0.01- $\mu$ F (minimum) ceramic capacitor rated for  $V_{CC}$  must be placed as close to the DRV5013-Q1 device as possible. Larger values of the bypass capacitor may be needed to attenuate any significant high-frequency ripple and noise components generated by the power source. TI recommends limiting the supply voltage variation to less than 50 mV<sub>pp</sub>.

## 10 Layout

### 10.1 Layout Guidelines

The bypass capacitor should be placed near the DRV5013-Q1 device for efficient power delivery with minimal inductance. The external pullup resistor should be placed near the microcontroller input to provide the most stable voltage at the input; alternatively, an integrated pullup resistor within the GPIO of the microcontroller can be used.

Generally, using PCB copper planes underneath the DRV5013-Q1 device has no effect on magnetic flux, and does not interfere with device performance. This is because copper is not a ferromagnetic material. However, if nearby system components contain iron or nickel, they may redirect magnetic flux in unpredictable ways.

### 10.2 Layout Example

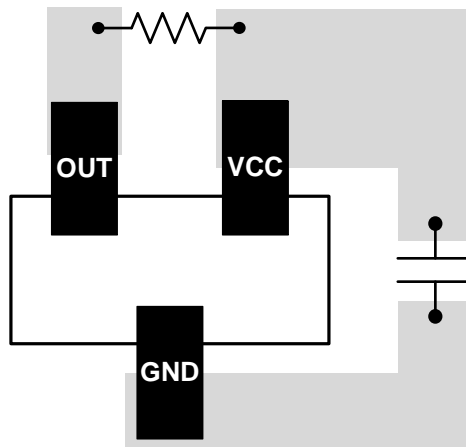

Figure 23. DRV5013-Q1 Layout Example

## 11 器件和文档支持

### 11.1 器件支持

#### 11.1.1 器件命名规则

图 24 显示了读取 DRV5013-Q1 器件完整器件名称的图例。



图 24. 器件命名规则

#### 11.1.2 器件标记



图 25. SOT-23 (DBZ) 封装

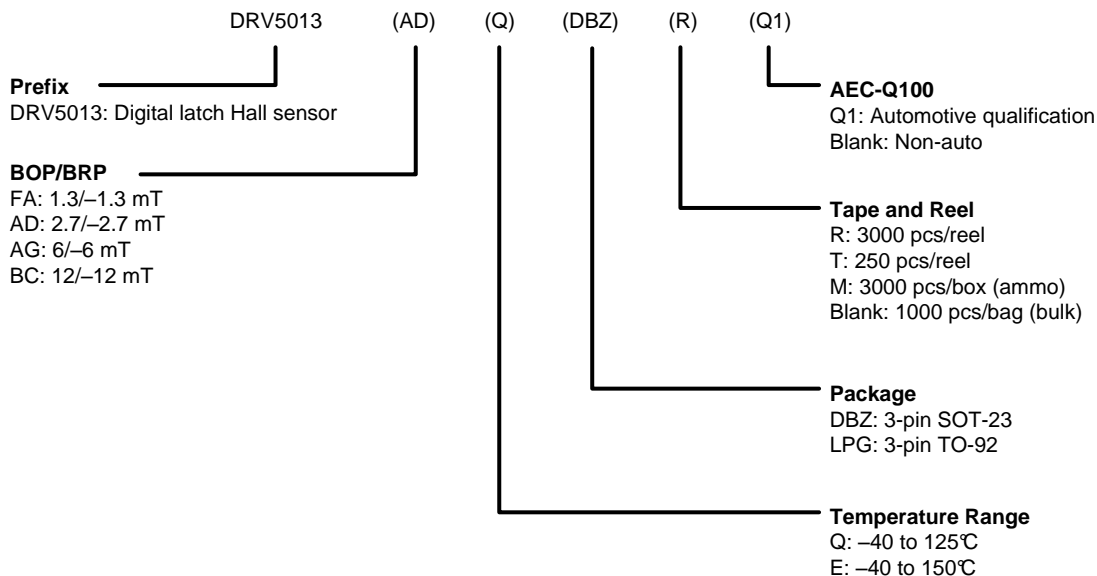

图 26. TO-92 (LPG) 封装

✚ 表示霍尔效应传感器（未按比例显示）。霍尔元件置于封装中央位置，容差为  $\pm 100\mu\text{m}$ 。在 DBZ 封装中，霍尔元件与封装底部的距离为  $0.7\text{mm} \pm 50\mu\text{m}$ ；在 LPG 封装中，霍尔元件与封装底部的距离为  $0.987\text{mm} \pm 50\mu\text{m}$ 。

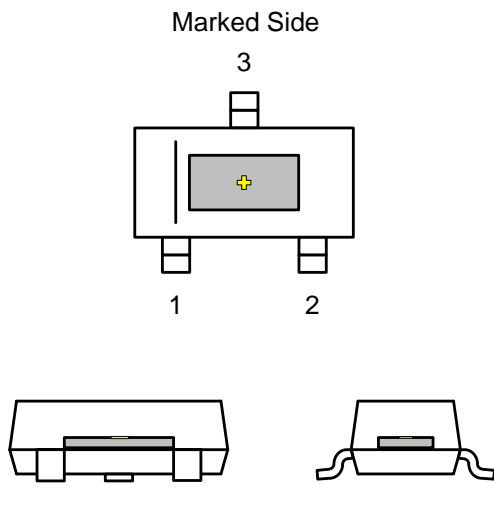
## 11.2 接收文档更新通知

要接收文档更新通知，请转至 [TI.com.cn](http://TI.com.cn) 上您的器件的产品文件夹。请在右上角单击 **通知我** 按钮进行注册，即可收到产品信息更改每周摘要（如有）。有关更改的详细信息，请查看任意已修订文档的修订历史记录。

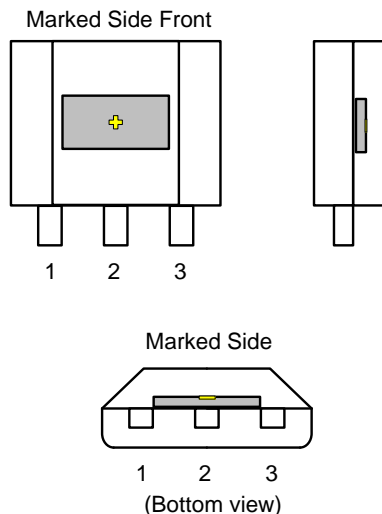
### 11.3 社区资源

下列链接提供到 TI 社区资源的连接。链接的内容由各个分销商“按照原样”提供。这些内容并不构成 TI 技术规范，并且不一定反映 TI 的观点；请参阅 TI 的《使用条款》。

**TI E2E™ 在线社区** *TI 的工程师对工程师 (E2E) 社区*。此社区的创建目的在于促进工程师之间的协作。在 [e2e.ti.com](http://e2e.ti.com) 中，您可以咨询问题、分享知识、拓展思路并与同行工程师一道帮助解决问题。

**设计支持** *TI 参考设计支持* 可帮助您快速查找有帮助的 E2E 论坛、设计支持工具以及技术支持的联系信息。

### 11.4 商标

E2E is a trademark of Texas Instruments.  
All other trademarks are the property of their respective owners.

### 11.5 静电放电警告



这些装置包含有限的内置 ESD 保护。存储或装卸时，应将导线一起截短或将装置放置于导电泡棉中，以防止 MOS 门极遭受静电损伤。

### 11.6 术语表

**SLYZ022** — *TI 术语表*。

这份术语表列出并解释术语、缩写和定义。

## 12 机械、封装和可订购信息

以下页面包含机械、封装和可订购信息。这些信息是指定器件的最新可用数据。数据如有变更，恕不另行通知，且不会对此文档进行修订。如需获取此数据表的浏览器版本，请查阅左侧的导航栏。

## 重要声明和免责声明

TI 均以“原样”提供技术性数据（包括数据表）、设计资源（包括参考设计）、应用或其他设计建议、网络工具、安全信息和其他资源，不保证其中不含任何瑕疵，且不做任何明示或暗示的担保，包括但不限于对适销性、适合某特定用途或不侵犯任何第三方知识产权的暗示担保。

所述资源可供专业开发人员应用TI 产品进行设计使用。您将对以下行为独自承担全部责任：(1) 针对您的应用选择合适的TI 产品；(2) 设计、验证并测试您的应用；(3) 确保您的应用满足相应标准以及任何其他安全、安保或其他要求。所述资源如有变更，恕不另行通知。TI 对您使用所述资源的授权仅限于开发资源所涉及TI 产品的相关应用。除此之外不得复制或展示所述资源，也不提供其它TI 或任何第三方的知识产权授权许可。如因使用所述资源而产生任何索赔、赔偿、成本、损失及债务等，TI 对此概不负责，并且您须赔偿由此对TI 及其代表造成的损害。

TI 所提供产品均受TI 的销售条款 (<http://www.ti.com.cn/zh-cn/legal/termsofsale.html>) 以及ti.com.cn上或随附TI产品提供的其他可适用条款的约束。TI提供所述资源并不扩展或以其他方式更改TI 针对TI 产品所发布的可适用的担保范围或担保免责声明。

邮寄地址：上海市浦东新区世纪大道 1568 号中建大厦 32 楼，邮政编码：200122  
Copyright © 2018 德州仪器半导体技术（上海）有限公司

**PACKAGING INFORMATION**

Orderable Device	Status (1)	Package Type	Package Drawing	Pins	Package Qty	Eco Plan (2)	Lead finish/ Ball material (6)	MSL Peak Temp (3)	Op Temp (°C)	Device Marking (4/5)	Samples
DRV5013ADEDBJQ1	ACTIVE	SOT-23	DBZ	3	10000	RoHS & Green	NIPDAUAG	Level-1-260C-UNLIM	-40 to 150	+NJAD	<a href="#">Samples</a>
DRV5013ADEDBZRQ1	ACTIVE	SOT-23	DBZ	3	3000	RoHS & Green	NIPDAUAG	Level-1-260C-UNLIM	-40 to 150	+NJAD	<a href="#">Samples</a>
DRV5013ADEDBZTQ1	ACTIVE	SOT-23	DBZ	3	250	RoHS & Green	NIPDAUAG	Level-1-260C-UNLIM	-40 to 150	+NJAD	<a href="#">Samples</a>
DRV5013ADELPGMQ1	ACTIVE	TO-92	LPG	3	3000	RoHS & Green	SN	N / A for Pkg Type	-40 to 150	+NJAD	<a href="#">Samples</a>
DRV5013ADELPGQ1	ACTIVE	TO-92	LPG	3	1000	RoHS & Green	SN	N / A for Pkg Type	-40 to 150	+NJAD	<a href="#">Samples</a>
DRV5013ADQDBZRQ1	ACTIVE	SOT-23	DBZ	3	3000	RoHS & Green	NIPDAUAG	Level-1-260C-UNLIM	-40 to 125	+NKAD	<a href="#">Samples</a>
DRV5013ADQDBZTQ1	ACTIVE	SOT-23	DBZ	3	250	RoHS & Green	NIPDAUAG	Level-1-260C-UNLIM	-40 to 125	+NKAD	<a href="#">Samples</a>
DRV5013ADQLPGMQ1	ACTIVE	TO-92	LPG	3	3000	RoHS & Green	SN	N / A for Pkg Type	-40 to 125	+NKAD	<a href="#">Samples</a>
DRV5013ADQLPGQ1	ACTIVE	TO-92	LPG	3	1000	RoHS & Green	SN	N / A for Pkg Type	-40 to 125	+NKAD	<a href="#">Samples</a>
DRV5013AGEDBZRQ1	ACTIVE	SOT-23	DBZ	3	3000	RoHS & Green	NIPDAUAG	Level-1-260C-UNLIM	-40 to 150	+NJAG	<a href="#">Samples</a>
DRV5013AGEDBZTQ1	ACTIVE	SOT-23	DBZ	3	250	RoHS & Green	NIPDAUAG	Level-1-260C-UNLIM	-40 to 150	+NJAG	<a href="#">Samples</a>
DRV5013AGELPGMQ1	ACTIVE	TO-92	LPG	3	3000	RoHS & Green	SN	N / A for Pkg Type	-40 to 150	+NJAG	<a href="#">Samples</a>
DRV5013AGELPGQ1	ACTIVE	TO-92	LPG	3	1000	RoHS & Green	SN	N / A for Pkg Type	-40 to 150	+NJAG	<a href="#">Samples</a>
DRV5013AGQDBZRQ1	ACTIVE	SOT-23	DBZ	3	3000	RoHS & Green	NIPDAUAG	Level-1-260C-UNLIM	-40 to 125	+NKAG	<a href="#">Samples</a>
DRV5013AGQDBZTQ1	ACTIVE	SOT-23	DBZ	3	250	RoHS & Green	NIPDAUAG	Level-1-260C-UNLIM	-40 to 125	+NKAG	<a href="#">Samples</a>
DRV5013AGQLPGMQ1	ACTIVE	TO-92	LPG	3	3000	RoHS & Green	SN	N / A for Pkg Type	-40 to 125	+NKAG	<a href="#">Samples</a>
DRV5013AGQLPGQ1	ACTIVE	TO-92	LPG	3	1000	RoHS & Green	SN	N / A for Pkg Type	-40 to 125	+NKAG	<a href="#">Samples</a>
DRV5013BCEDBZRQ1	ACTIVE	SOT-23	DBZ	3	3000	RoHS & Green	NIPDAUAG	Level-1-260C-UNLIM	-40 to 150	+NJBC	<a href="#">Samples</a>
DRV5013BCEDBZTQ1	ACTIVE	SOT-23	DBZ	3	250	RoHS & Green	NIPDAUAG	Level-1-260C-UNLIM	-40 to 150	+NJBC	<a href="#">Samples</a>
DRV5013BCELPGMQ1	ACTIVE	TO-92	LPG	3	3000	RoHS & Green	SN	N / A for Pkg Type	-40 to 150	+NJBC	<a href="#">Samples</a>

Orderable Device	Status (1)	Package Type	Package Drawing	Pins	Package Qty	Eco Plan (2)	Lead finish/ Ball material (6)	MSL Peak Temp (3)	Op Temp (°C)	Device Marking (4/5)	Samples
DRV5013BCELPQG1	ACTIVE	TO-92	LPG	3	1000	RoHS & Green	SN	N / A for Pkg Type	-40 to 150	+NJBC	<a href="#">Samples</a>
DRV5013BCQDBZRQ1	ACTIVE	SOT-23	DBZ	3	3000	RoHS & Green	NIPDAUAG	Level-1-260C-UNLIM	-40 to 125	+NKBC	<a href="#">Samples</a>
DRV5013BCQDBZTQ1	ACTIVE	SOT-23	DBZ	3	250	RoHS & Green	NIPDAUAG	Level-1-260C-UNLIM	-40 to 125	+NKBC	<a href="#">Samples</a>
DRV5013BCQLPGMQ1	ACTIVE	TO-92	LPG	3	3000	RoHS & Green	SN	N / A for Pkg Type	-40 to 125	+NKBC	<a href="#">Samples</a>
DRV5013BCQLPGQ1	ACTIVE	TO-92	LPG	3	1000	RoHS & Green	SN	N / A for Pkg Type	-40 to 125	+NKBC	<a href="#">Samples</a>
DRV5013FAEDBZRQ1	ACTIVE	SOT-23	DBZ	3	3000	RoHS & Green	SN	Level-1-260C-UNLIM	-40 to 150	+NJFA	<a href="#">Samples</a>

(1) The marketing status values are defined as follows:

**ACTIVE:** Product device recommended for new designs.

**LIFEBUY:** TI has announced that the device will be discontinued, and a lifetime-buy period is in effect.

**NRND:** Not recommended for new designs. Device is in production to support existing customers, but TI does not recommend using this part in a new design.

**PREVIEW:** Device has been announced but is not in production. Samples may or may not be available.

**OBSELETE:** TI has discontinued the production of the device.

(2) **RoHS:** TI defines "RoHS" to mean semiconductor products that are compliant with the current EU RoHS requirements for all 10 RoHS substances, including the requirement that RoHS substance do not exceed 0.1% by weight in homogeneous materials. Where designed to be soldered at high temperatures, "RoHS" products are suitable for use in specified lead-free processes. TI may reference these types of products as "Pb-Free".

**RoHS Exempt:** TI defines "RoHS Exempt" to mean products that contain lead but are compliant with EU RoHS pursuant to a specific EU RoHS exemption.

**Green:** TI defines "Green" to mean the content of Chlorine (Cl) and Bromine (Br) based flame retardants meet JS709B low halogen requirements of <=1000ppm threshold. Antimony trioxide based flame retardants must also meet the <=1000ppm threshold requirement.

(3) MSL, Peak Temp. - The Moisture Sensitivity Level rating according to the JEDEC industry standard classifications, and peak solder temperature.

(4) There may be additional marking, which relates to the logo, the lot trace code information, or the environmental category on the device.

(5) Multiple Device Markings will be inside parentheses. Only one Device Marking contained in parentheses and separated by a "~" will appear on a device. If a line is indented then it is a continuation of the previous line and the two combined represent the entire Device Marking for that device.

(6) Lead finish/Ball material - Orderable Devices may have multiple material finish options. Finish options are separated by a vertical ruled line. Lead finish/Ball material values may wrap to two lines if the finish value exceeds the maximum column width.

**Important Information and Disclaimer:** The information provided on this page represents TI's knowledge and belief as of the date that it is provided. TI bases its knowledge and belief on information provided by third parties, and makes no representation or warranty as to the accuracy of such information. Efforts are underway to better integrate information from third parties. TI has taken and continues to take reasonable steps to provide representative and accurate information but may not have conducted destructive testing or chemical analysis on incoming materials and chemicals. TI and TI suppliers consider certain information to be proprietary, and thus CAS numbers and other limited information may not be available for release.

In no event shall TI's liability arising out of such information exceed the total purchase price of the TI part(s) at issue in this document sold by TI to Customer on an annual basis.

**TAPE AND REEL INFORMATION**

**QUADRANT ASSIGNMENTS FOR PIN 1 ORIENTATION IN TAPE**

\*All dimensions are nominal

Device	Package Type	Package Drawing	Pins	SPQ	Reel Diameter (mm)	Reel Width W1 (mm)	A0 (mm)	B0 (mm)	K0 (mm)	P1 (mm)	W (mm)	Pin1 Quadrant
DRV5013AEDDBZJQ1	SOT-23	DBZ	3	10000	330.0	8.4	3.15	2.77	1.22	4.0	8.0	Q3
DRV5013AEDDBZRQ1	SOT-23	DBZ	3	3000	180.0	8.4	3.15	2.77	1.22	4.0	8.0	Q3
DRV5013AEDDBZTQ1	SOT-23	DBZ	3	250	180.0	8.4	3.15	2.77	1.22	4.0	8.0	Q3
DRV5013ADQDBZRQ1	SOT-23	DBZ	3	3000	180.0	8.4	3.15	2.77	1.22	4.0	8.0	Q3
DRV5013ADQDBZTQ1	SOT-23	DBZ	3	250	180.0	8.4	3.15	2.77	1.22	4.0	8.0	Q3
DRV5013AGEDBZRQ1	SOT-23	DBZ	3	3000	180.0	8.4	3.15	2.77	1.22	4.0	8.0	Q3
DRV5013AGEDBZTQ1	SOT-23	DBZ	3	250	180.0	8.4	3.15	2.77	1.22	4.0	8.0	Q3
DRV5013AGQDBZRQ1	SOT-23	DBZ	3	3000	180.0	8.4	3.15	2.77	1.22	4.0	8.0	Q3
DRV5013AGQDBZTQ1	SOT-23	DBZ	3	250	180.0	8.4	3.15	2.77	1.22	4.0	8.0	Q3
DRV5013BCEDBZRQ1	SOT-23	DBZ	3	3000	180.0	8.4	3.15	2.77	1.22	4.0	8.0	Q3
DRV5013BCEDBZTQ1	SOT-23	DBZ	3	250	180.0	8.4	3.15	2.77	1.22	4.0	8.0	Q3
DRV5013BCQDBZRQ1	SOT-23	DBZ	3	3000	180.0	8.4	3.15	2.77	1.22	4.0	8.0	Q3
DRV5013BCQDBZTQ1	SOT-23	DBZ	3	250	180.0	8.4	3.15	2.77	1.22	4.0	8.0	Q3
DRV5013FAEDBZRQ1	SOT-23	DBZ	3	3000	180.0	8.4	3.15	2.77	1.22	4.0	8.0	Q3

**TAPE AND REEL BOX DIMENSIONS**

\*All dimensions are nominal

Device	Package Type	Package Drawing	Pins	SPQ	Length (mm)	Width (mm)	Height (mm)
DRV5013ADEDZJQ1	SOT-23	DBZ	3	10000	346.0	346.0	29.0
DRV5013ADEDZBZRQ1	SOT-23	DBZ	3	3000	202.0	201.0	28.0
DRV5013ADEDZBTQ1	SOT-23	DBZ	3	250	202.0	201.0	28.0
DRV5013ADQDBZRQ1	SOT-23	DBZ	3	3000	202.0	201.0	28.0
DRV5013ADQDBZTQ1	SOT-23	DBZ	3	250	202.0	201.0	28.0
DRV5013AGEDBZRQ1	SOT-23	DBZ	3	3000	202.0	201.0	28.0
DRV5013AGEDBZTQ1	SOT-23	DBZ	3	250	202.0	201.0	28.0
DRV5013AGQDBZRQ1	SOT-23	DBZ	3	3000	202.0	201.0	28.0
DRV5013AGQDBZTQ1	SOT-23	DBZ	3	250	202.0	201.0	28.0
DRV5013BCEDBZRQ1	SOT-23	DBZ	3	3000	202.0	201.0	28.0
DRV5013BCEDBZTQ1	SOT-23	DBZ	3	250	202.0	201.0	28.0
DRV5013BCQDBZRQ1	SOT-23	DBZ	3	3000	202.0	201.0	28.0
DRV5013BCQDBZTQ1	SOT-23	DBZ	3	250	202.0	201.0	28.0
DRV5013FAEDBZRQ1	SOT-23	DBZ	3	3000	202.0	201.0	28.0

# LPG0003A



# PACKAGE OUTLINE

## TO-92 - 5.05 mm max height

TRANSISTOR OUTLINE

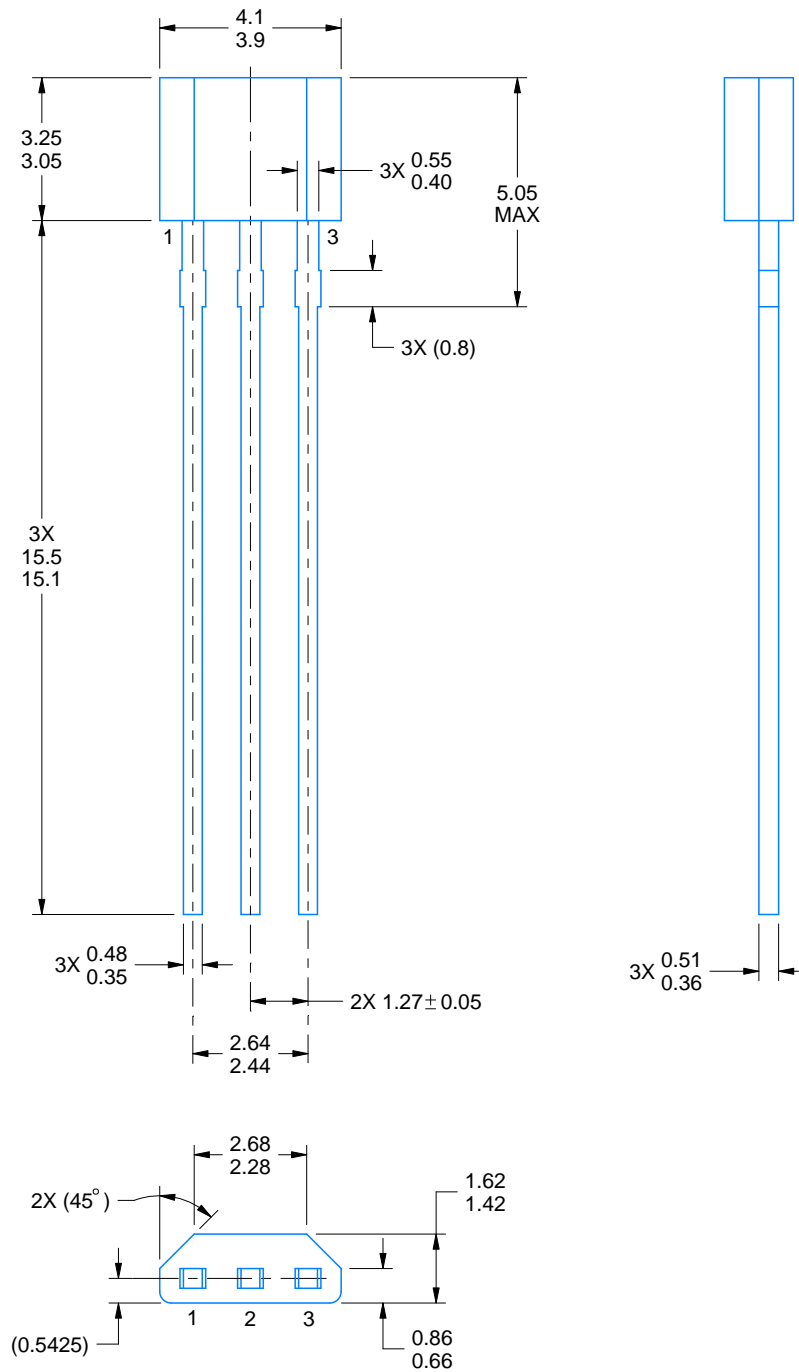

4221343/C 01/2018

### NOTES:

1. All linear dimensions are in millimeters. Any dimensions in parenthesis are for reference only. Dimensioning and tolerancing per ASME Y14.5M.
2. This drawing is subject to change without notice.

# EXAMPLE BOARD LAYOUT

LPG0003A

TO-92 - 5.05 mm max height

TRANSISTOR OUTLINE

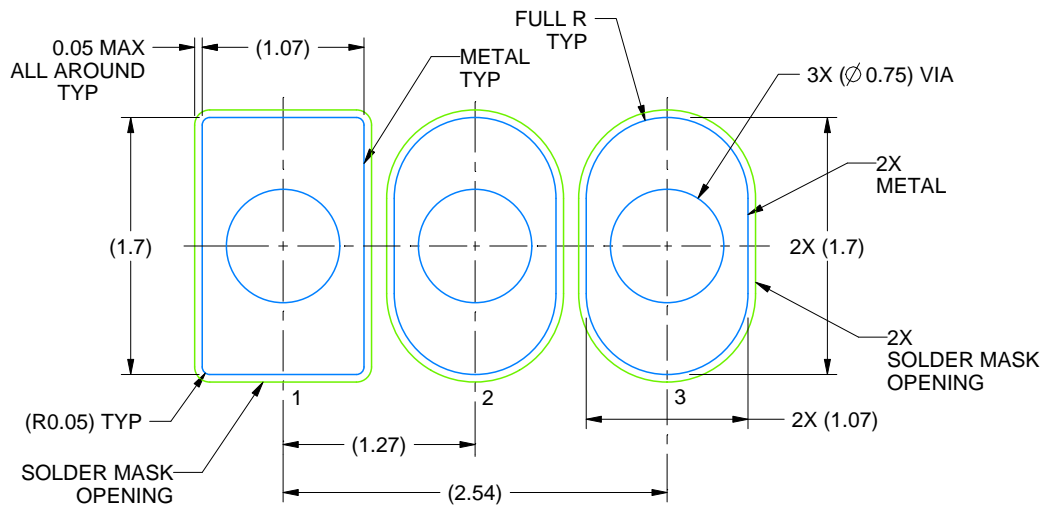

LAND PATTERN EXAMPLE  
NON-SOLDER MASK DEFINED  
SCALE:20X

4221343/C 01/2018

# TAPE SPECIFICATIONS

LPG0003A

TO-92 - 5.05 mm max height

TRANSISTOR OUTLINE

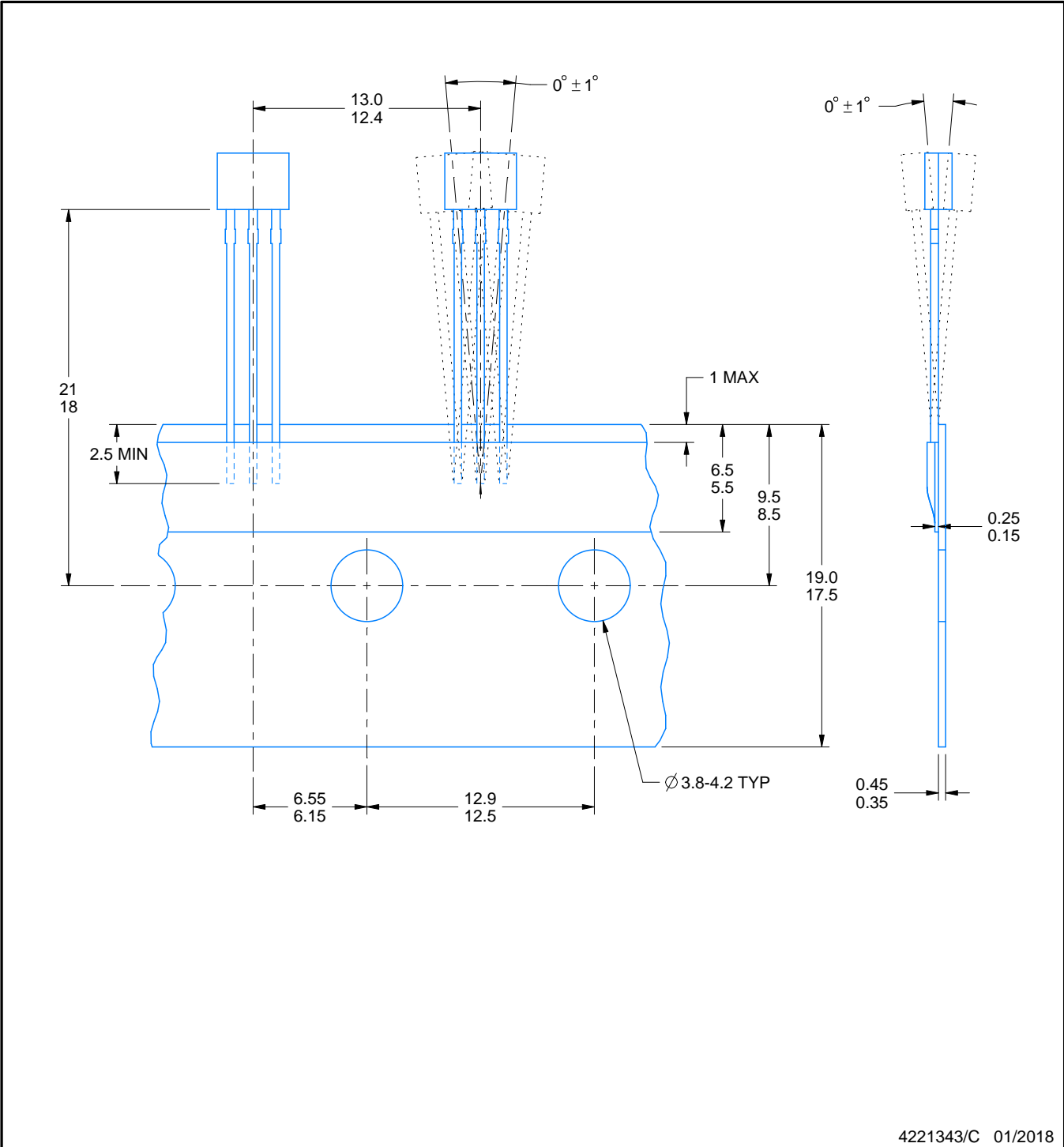

## GENERIC PACKAGE VIEW

**DBZ 3**

**SOT-23 - 1.12 mm max height**

SMALL OUTLINE TRANSISTOR

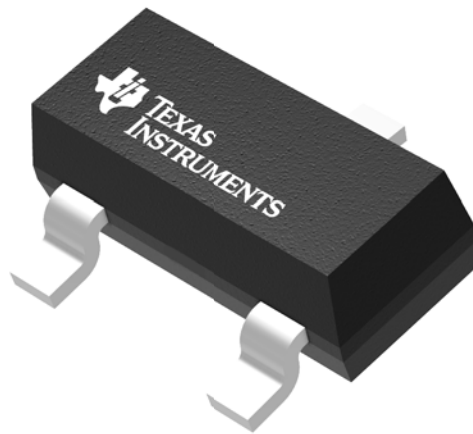

Images above are just a representation of the package family, actual package may vary.  
Refer to the product data sheet for package details.

4203227/C



# EXAMPLE BOARD LAYOUT

DBZ0003A

SOT-23 - 1.12 mm max height

SMALL OUTLINE TRANSISTOR

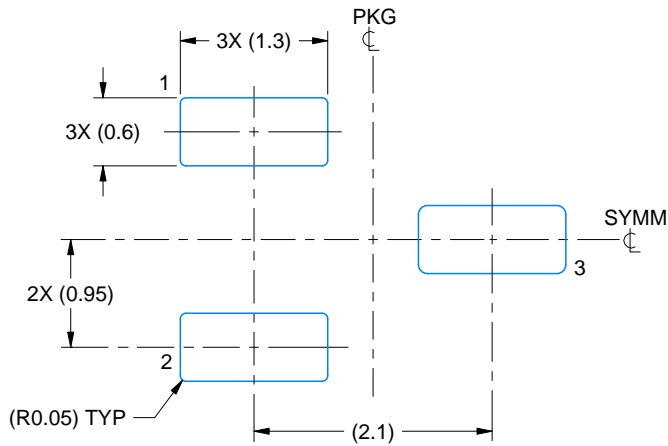

LAND PATTERN EXAMPLE  
SCALE:15X

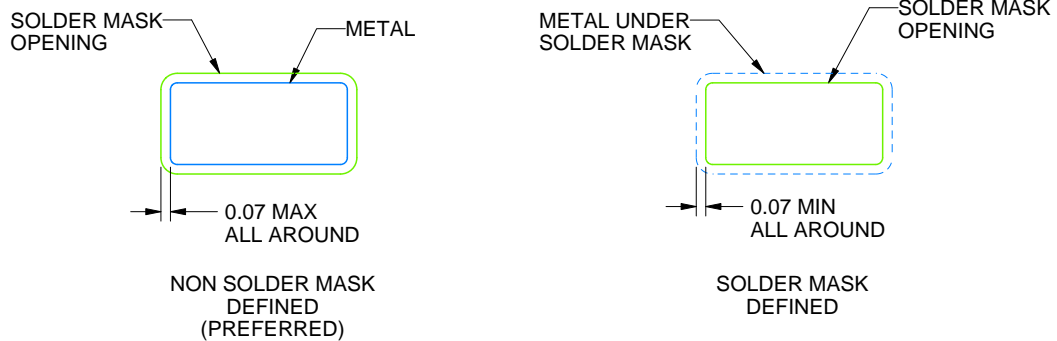

SOLDER MASK DETAILS

4214838/C 04/2017

NOTES: (continued)

4. Publication IPC-7351 may have alternate designs.
5. Solder mask tolerances between and around signal pads can vary based on board fabrication site.

# EXAMPLE STENCIL DESIGN

DBZ0003A

SOT-23 - 1.12 mm max height

SMALL OUTLINE TRANSISTOR

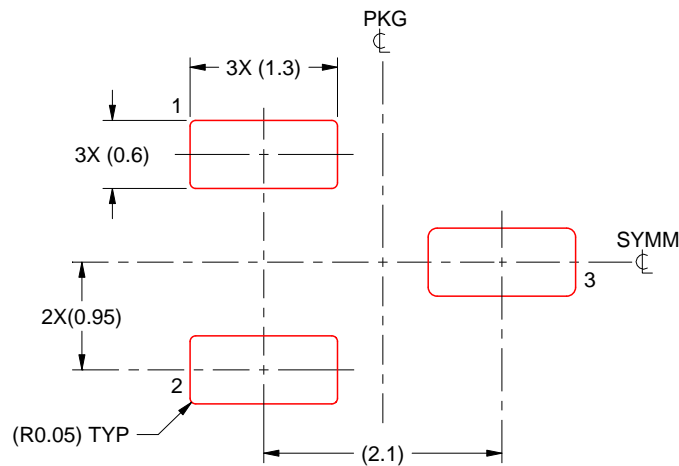

SOLDER PASTE EXAMPLE  
BASED ON 0.125 THICK STENCIL  
SCALE:15X

4214838/C 04/2017

NOTES: (continued)

6. Laser cutting apertures with trapezoidal walls and rounded corners may offer better paste release. IPC-7525 may have alternate design recommendations.
7. Board assembly site may have different recommendations for stencil design.

## 重要声明和免责声明

TI 均以“原样”提供技术性 & 可靠性数据（包括数据表）、设计资源（包括参考设计）、应用或其他设计建议、网络工具、安全信息和其他资源，不保证其中不含任何瑕疵，且不做任何明示或暗示的担保，包括但不限于对适销性、适合某特定用途或不侵犯任何第三方知识产权的暗示担保。

所述资源可供专业开发人员应用 TI 产品进行设计使用。您将对以下行为独自承担全部责任：(1) 针对您的应用选择合适的 TI 产品；(2) 设计、验证并测试您的应用；(3) 确保您的应用满足相应标准以及任何其他安全、安保或其他要求。所述资源如有变更，恕不另行通知。TI 对您使用所述资源的授权仅限于开发资源所涉及 TI 产品的相关应用。除此之外不得复制或展示所述资源，也不提供其它 TI 或任何第三方的知识产权授权许可。如因使用所述资源而产生任何索赔、赔偿、成本、损失及债务等，TI 对此概不负责，并且您须赔偿由此对 TI 及其代表造成的损害。

TI 所提供产品均受 TI 的销售条款 (<http://www.ti.com.cn/zh-cn/legal/termsofsale.html>) 以及 [ti.com.cn](http://www.ti.com.cn) 上或随附 TI 产品提供的其他可适用条款的约束。TI 提供所述资源并不扩展或以其他方式更改 TI 针对 TI 产品所发布的可适用的担保范围或担保免责声明。

邮寄地址：上海市浦东新区世纪大道 1568 号中建大厦 32 楼，邮政编码：200122

Copyright © 2020 德州仪器半导体技术（上海）有限公司