

TXB0106 6-Bit Bidirectional Level-Shifting and Voltage Translator With Auto-Direction Sensing and ± 15 -kV ESD Protection

1 Features

- 1.2 V to 3.6 V on A Port and 1.65 to 5.5 V on B Port ($V_{CCA} \leq V_{CCB}$)
- V_{CC} Isolation Feature – If Either V_{CC} Input Is at GND, All Outputs Are in the High-Impedance State
- OE Input Circuit Referenced to V_{CCA}
- Low-Power Consumption, 4 μ A Max I_{CC}
- I_{off} Supports Partial-Power-Down Mode Operation
- Latch-Up Performance Exceeds 100 mA Per JESD 78, Class II
- ESD Protection Exceeds JESD 22
 - A Port
 - 2500 V Human Body Model (A114-B)
 - 150 V Machine Model (A115-A)
 - 1500 V Charged-Device Model (C101)
 - B Port
 - ± 15 kV Human Body Model (A114-B)
 - 150 V Machine Model (A115-A)
 - 1500 V Charged-Device Model (C101)

2 Applications

- Headset
- Smartphone
- Tablet
- Desktop PC

3 Description

This 6-bit noninverting translator uses two separate configurable power-supply rails. The A port is designed to track V_{CCA} . V_{CCA} accepts any supply voltage from 1.2 V to 3.6 V. The B port is designed to track V_{CCB} . V_{CCB} accepts any supply voltage from 1.65 V to 5.5 V. This allows for universal low-voltage bidirectional translation between any of the 1.2 V, 1.5 V, 1.8 V, 2.5 V, 3.3 V, and 5 V voltage nodes. V_{CCA} should not exceed V_{CCB} .

When the output-enable (OE) input is low, all outputs are placed in the high-impedance state.

The TXB0106 is designed so that the OE input circuit is supplied by V_{CCA} .

This device is fully specified for partial-power-down applications using I_{off} . The I_{off} circuitry disables the outputs, preventing damaging current backflow through the device when it is powered down.

To ensure the high-impedance state during power up or power down, OE should be tied to GND through a pulldown resistor; the minimum value of the resistor is determined by the current-sourcing capability of the driver.

Device Information⁽¹⁾

PART NUMBER	PACKAGE	BODY SIZE (NOM)
TXB0106	TSSOP (16)	5.00 mm x 4.40 mm
	VQFN (16)	4.00 mm x 3.50 mm

(1) For all available packages, see the orderable addendum at the end of the datasheet.

Typical Application Block Diagram for TXB010X

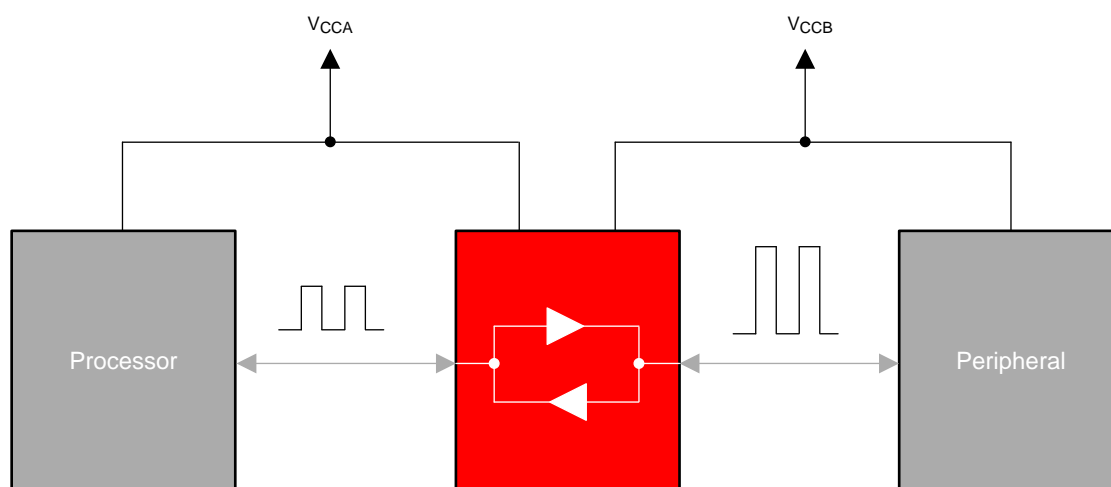

Table of Contents

1 Features	1	6.17 Typical Characteristics	9
2 Applications	1	7 Parameter Measurement Information	10
3 Description	1	8 Detailed Description	10
4 Revision History	2	8.1 Overview	10
5 Pin Configuration and Functions	3	8.2 Functional Block Diagram	11
6 Specifications	4	8.3 Feature Description	12
6.1 Absolute Maximum Ratings	4	9 Application and Implementation	15
6.2 ESD Ratings	4	9.1 Application Information	15
6.3 Recommended Operating Conditions	4	9.2 Typical Application	15
6.4 Thermal Information	5	10 Power Supply Recommendations	16
6.5 Electrical Characteristics	5	11 Layout	17
6.6 Timing Requirements: $V_{CCA} = 1.2\text{ V}$	6	11.1 Layout Guidelines	17
6.7 Timing Requirements: $V_{CCA} = 1.5\text{ V} \pm 0.1\text{ V}$	6	11.2 Layout Example	17
6.8 Timing Requirements: $V_{CCA} = 1.8\text{ V} \pm 0.2\text{ V}$	6	12 Device and Documentation Support	18
6.9 Timing Requirements: $V_{CCA} = 2.5\text{ V} \pm 0.2\text{ V}$	6	12.1 Documentation Support	18
6.10 Timing Requirements: $V_{CCA} = 3.3\text{ V} \pm 0.3\text{ V}$	6	12.2 Community Resources	18
6.11 Switching Characteristics: $V_{CCA} = 1.2\text{ V}$	6	12.3 Trademarks	18
6.12 Switching Characteristics: $V_{CCA} = 1.5\text{ V} \pm 0.1\text{ V}$	7	12.4 Electrostatic Discharge Caution	18
6.13 Switching Characteristics: $V_{CCA} = 1.8\text{ V} \pm 0.15\text{ V}$	7	12.5 Glossary	18
6.14 Switching Characteristics: $V_{CCA} = 2.5\text{ V} \pm 0.2\text{ V}$	8	13 Mechanical, Packaging, and Orderable Information	18
6.15 Switching Characteristics: $V_{CCA} = 3.3\text{ V} \pm 0.3\text{ V}$	8		
6.16 Operating Characteristics	8		

4 Revision History

NOTE: Page numbers for previous revisions may differ from page numbers in the current version.

Changes from Revision A (May 2012) to Revision B

Page

- Added *Pin Configuration and Functions* section, *ESD Ratings* table, *Feature Description* section, *Device Functional Modes*, *Application and Implementation* section, *Power Supply Recommendations* section, *Layout* section, *Device and Documentation Support* section, and *Mechanical, Packaging, and Orderable Information* section **1**

Changes from Original (September 2008) to Revision A

Page

- Added notes to pin out graphics

5 Pin Configuration and Functions

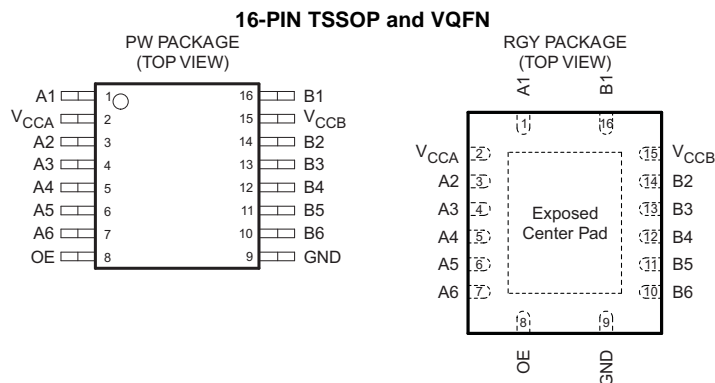

- A. The exposed center pad, if used, must be connected as a secondary ground or left electrically open.
- B. Pull up resistors are not required on both sides for Logic I/O.
- C. If pull up or pull down resistors are needed, the resistor value must be over 50 k Ω .
- D. 50 k Ω is a safe recommended value, if the customer can accept higher V_{OL} or lower V_{OH} , smaller pull up or pull down resistor is allowed, the draft estimation is $V_{OL} = V_{CCOUT} \times 4.5 \text{ k} / (4.5 \text{ k} + R_{PU})$ and $V_{OH} = V_{CCOUT} \times R_{DW} / (4.5 \text{ k} + R_{DW})$.
- E. If pull up resistors are needed, please refer to the TXS0108 (different package with TXB0106) or contact TI.
- F. For detailed information, please refer to application note [SCEA043](#).

Pin Functions

PIN		I/O	DESCRIPTION
NO.	NAME		
1	A1		Input/output 1. Referenced to V_{CCA} .
2	V_{CCA}	-	A-port supply voltage. $1.2 \text{ V} \leq V_{CCA} \leq 3.6 \text{ V}$, $V_{CCA} \leq V_{CCB}$.
3	A2	I/O	Input/output 2. Referenced to V_{CCA} .
4	A3	I/O	Input/output 3. Referenced to V_{CCA} .
5	A4	I/O	Input/output 4. Referenced to V_{CCA} .
6	A5	I/O	Input/output 5. Referenced to V_{CCA} .
7	A6	I/O	Input/output 6. Referenced to V_{CCA} .
8	OE	-	Output enable. Pull OE low to place all outputs in Tri-state mode. Referenced to V_{CCA} .
9	GND	-	Ground
10	B6	I/O	Input/output 6. Referenced to V_{CCB} .
11	B5	I/O	Input/output 5. Referenced to V_{CCB} .
12	B4	I/O	Input/output 4. Referenced to V_{CCB} .
13	B3	I/O	Input/output 3. Referenced to V_{CCB} .
14	B2	I/O	Input/output 2. Referenced to V_{CCB} .
15	V_{CCB}	-	B-port supply voltage. $1.65 \text{ V} \leq V_{CCB} \leq 5.5 \text{ V}$.
16	B1	I/O	Input/output 1. Referenced to V_{CCB} .

6 Specifications

6.1 Absolute Maximum Ratings

over operating free-air temperature range (unless otherwise noted)⁽¹⁾

		MIN	MAX	UNIT	
V _{CCA}	Supply voltage	-0.5	4.6	V	
V _{CCB}	Supply voltage	-0.5	6.5	V	
V _I	Input voltage ⁽²⁾	-0.5	6.5	V	
V _O	Voltage applied to any output in the high-impedance or power-off state ⁽²⁾	-0.5	6.5	V	
V _O	Voltage applied to any output in the high or low state ⁽²⁾ (3)	A inputs	-0.5	V _{CCA} + 0.5	V
		B inputs	-0.5	V _{CCB} + 0.5	
I _{IK}	Input clamp current		-50	mA	
I _{OK}	Output clamp current		-50	mA	
I _O	Continuous output current		±50	mA	
	Continuous current through V _{CCA} , V _{CCB} , or GND		±100	mA	
T _J	Junction Temperature	-40	150	°C	
T _{stg}	Storage temperature	-65	150	°C	

- (1) Stresses beyond those listed under *Absolute Maximum Ratings* may cause permanent damage to the device. These are stress ratings only, and functional operation of the device at these or any other conditions beyond those indicated under *Recommended Operating Conditions* is not implied. Exposure to absolute-maximum-rated conditions for extended periods may affect device reliability.
- (2) The input and output negative-voltage ratings may be exceeded if the input and output current ratings are observed.
- (3) The value of V_{CCA} and V_{CCB} are provided in the recommended operating conditions table.

6.2 ESD Ratings

		VALUE	UNIT		
V _(ESD)	Electrostatic discharge	Human body model (HBM), per ANSI/ESDA/JEDEC JS-001 ⁽¹⁾	A Port	2500	V
			B Port	±15000	
		Charged-device model (CDM), per JEDEC specification JESD22-C101 ⁽²⁾	A Port	1500	
			B Port		
		Machine model (A115-A)	A Port	150	
			B Port		

- (1) JEDEC document JEP155 states that 500 V HBM allows safe manufacturing with a standard ESD control process.
- (2) JEDEC document JEP157 states that 250 V CDM allows safe manufacturing with a standard ESD control process.

6.3 Recommended Operating Conditions⁽¹⁾ (2)

		V _{CCA}	V _{CCB}	MIN	MAX	UNIT	
V _{CCA}	Supply voltage			1.2	3.6	V	
		V _{CCB}		1.65	5.5		
V _{IH}	High-level input voltage	Data inputs	1.2 V to 3.6 V	1.65 V to 5.5 V	V _{CCI} × 0.65 ⁽³⁾	V _{CCI}	
		OE			V _{CCA} × 0.65		5.5
V _{IL}	Low-level input voltage	Data inputs	1.2 V to 5.5 V	1.65 V to 5.5 V	0	V _{CCI} × 0.35 ⁽³⁾	
		OE			1.2 V to 3.6 V		0
Δt/Δv	Input transition rise or fall rate	A-port inputs	1.2 V to 3.6 V	1.65 V to 5.5 V		ns/V	
		B-port inputs		1.65 V to 3.6 V			40
				1.2 V to 3.6 V	4.5 V to 5.5 V		
T _A	Operating free-air temperature			-40	85	°C	

- (1) The A and B sides of an unused data I/O pair must be held in the same state, i.e., both at V_{CCI} or both at GND.
- (2) V_{CCA} must be less than or equal to V_{CCB} and must not exceed 3.6 V.
- (3) V_{CCI} is the supply voltage associated with the input port.

6.4 Thermal Information

THERMAL METRIC ⁽¹⁾		TXB0106		UNIT
		PW (TSSOP)	RGY (VQFN)	
		16 PINS	16 PINS	
R _{θJA}	Junction-to-ambient thermal resistance	107.2	40.7	°C/W
R _{θJC(top)}	Junction-to-case (top) thermal resistance	34.9	54.1	°C/W
R _{θJB}	Junction-to-board thermal resistance	13.3	20.9	°C/W
ψ _{JT}	Junction-to-top characterization parameter	0.5	1.1	°C/W
ψ _{JB}	Junction-to-board characterization parameter	13.3	20.9	°C/W
R _{θJC(bot)}	Junction-to-case (bottom) thermal resistance	2.7	6.7	°C/W

(1) For more information about traditional and new thermal metrics, see the *Semiconductor and IC Package Thermal Metrics* application report, [SPRA953](#).

6.5 Electrical Characteristics

over recommended operating free-air temperature range (unless otherwise noted)⁽¹⁾⁽²⁾

PARAMETER		TEST CONDITIONS	V _{CCA}	V _{CCB}	T _A = 25°C			-40°C to 85°C		UNIT
					MIN	TYP	MAX	MIN	MAX	
V _{OHA}		I _{OH} = -20 μA	1.2 V		1.1			V _{CCA} - 0.4		V
			1.4 V to 3.6 V							
V _{OLA}		I _{OL} = 20 μA	1.2 V		0.9			0.4		V
			1.4 V to 3.6 V							
V _{OHB}		I _{OH} = -20 μA		1.65 V to 5.5 V				V _{CCB} - 0.4		V
V _{OLB}		I _{OL} = 20 μA		1.65 V to 5.5 V				0.4		V
I _I	OE		1.2 V to 3.6 V	1.65 V to 5.5 V	±1			±2		μA
I _{off}	A port		0 V	0 V to 5.5 V	±1			±2		μA
	B port		0 V to 3.6 V	0 V	±1			±2		
I _{OZ}	A or B port	OE = GND	1.2 V to 3.6 V	1.65 V to 5.5 V	±1			±2		μA
I _{CCA}		V _I = V _{CC1} or GND, I _O = 0	1.2 V	1.65 V to 5.5 V	0.06			5		μA
			1.4 V to 3.6 V							
			3.6 V	0 V				2		
			0 V	5.5 V				2		
I _{CCB}		V _I = V _{CC1} or GND, I _O = 0	1.2 V	1.65 V to 5.5 V	3.4			5		μA
			1.4 V to 3.6 V							
			3.6 V	0 V				-2		
			0 V	5.5 V				2		
I _{CCA} + I _{CCB}		V _I = V _{CC1} or GND, I _O = 0	1.2 V	1.65 V to 5.5 V	3.5			10		μA
			1.4 V to 3.6 V							
I _{CCZA}		V _I = V _{CC1} or GND, I _O = 0, OE = GND	1.2 V	1.65 V to 5.5 V	0.05			5		μA
			1.4 V to 3.6 V							
I _{CCZB}		V _I = V _{CC1} or GND, I _O = 0, OE = GND	1.2 V	1.65 V to 5.5 V	3.3			5		μA
			1.4 V to 3.6 V							
C _I	OE		1.2 V to 3.6 V	1.65 V to 5.5 V	5			5.5		pF
C _{io}	A port		1.2 V to 3.6 V	1.65 V to 5.5 V	5			6.5		pF
	B port				8			10		

(1) V_{CC1} is the supply voltage associated with the input port.

(2) V_{CC0} is the supply voltage associated with the output port.

6.6 Timing Requirements: $V_{CCA} = 1.2\text{ V}$

 $T_A = 25^\circ\text{C}$, $V_{CCA} = 1.2\text{ V}$

		$V_{CCB} = 1.8\text{ V}$	$V_{CCB} = 2.5\text{ V}$	$V_{CCB} = 3.3\text{ V}$	$V_{CCB} = 5\text{ V}$	UNIT
		NOM	NOM	NOM	NOM	
Data rate		20	20	20	20	Mbps
t_w	Pulse duration	Data inputs	50	50	50	ns

6.7 Timing Requirements: $V_{CCA} = 1.5\text{ V} \pm 0.1\text{ V}$

 over recommended operating free-air temperature range, $V_{CCA} = 1.5\text{ V} \pm 0.1\text{ V}$ (unless otherwise noted)

		$V_{CCB} = 1.8\text{ V} \pm 0.15\text{ V}$		$V_{CCB} = 2.5\text{ V} \pm 0.2\text{ V}$		$V_{CCB} = 3.3\text{ V} \pm 0.3\text{ V}$		$V_{CCB} = 5\text{ V} \pm 0.5\text{ V}$		UNIT
		MIN	MAX	MIN	MAX	MIN	MAX	MIN	MAX	
Data rate		50		50		50		50		Mbps
t_w	Pulse duration	Data inputs	20	20	20	20	20	20	ns	

6.8 Timing Requirements: $V_{CCA} = 1.8\text{ V} \pm 0.15\text{ V}$

 over recommended operating free-air temperature range, $V_{CCA} = 1.8\text{ V} \pm 0.15\text{ V}$ (unless otherwise noted)

		$V_{CCB} = 1.8\text{ V} \pm 0.15\text{ V}$		$V_{CCB} = 2.5\text{ V} \pm 0.2\text{ V}$		$V_{CCB} = 3.3\text{ V} \pm 0.3\text{ V}$		$V_{CCB} = 5\text{ V} \pm 0.5\text{ V}$		UNIT
		MIN	MAX	MIN	MAX	MIN	MAX	MIN	MAX	
Data rate		52		60		60		60		Mbps
t_w	Pulse duration	Data inputs	19	17	17	17	17	ns		

6.9 Timing Requirements: $V_{CCA} = 2.5\text{ V} \pm 0.2\text{ V}$

 over recommended operating free-air temperature range, $V_{CCA} = 2.5\text{ V} \pm 0.2\text{ V}$ (unless otherwise noted)

		$V_{CCB} = 2.5\text{ V} \pm 0.2\text{ V}$		$V_{CCB} = 3.3\text{ V} \pm 0.3\text{ V}$		$V_{CCB} = 5\text{ V} \pm 0.5\text{ V}$		UNIT
		MIN	MAX	MIN	MAX	MIN	MAX	
Data rate		70		100		100		Mbps
t_w	Pulse duration	Data inputs	14	10	10	10	ns	

6.10 Timing Requirements: $V_{CCA} = 3.3\text{ V} \pm 0.3\text{ V}$

 over recommended operating free-air temperature range, $V_{CCA} = 3.3\text{ V} \pm 0.3\text{ V}$ (unless otherwise noted)

		$V_{CCB} = 3.3\text{ V} \pm 0.3\text{ V}$		$V_{CCB} = 5\text{ V} \pm 0.5\text{ V}$		UNIT
		MIN	MAX	MIN	MAX	
Data rate		100		100		Mbps
t_w	Pulse duration	Data inputs	10	10	ns	

6.11 Switching Characteristics: $V_{CCA} = 1.2\text{ V}$

 $T_A = 25^\circ\text{C}$, $V_{CCA} = 1.2\text{ V}$

PARAMETER	FROM (INPUT)	TO (OUTPUT)	$V_{CCB} = 1.8\text{ V}$	$V_{CCB} = 2.5\text{ V}$	$V_{CCB} = 3.3\text{ V}$	$V_{CCB} = 5\text{ V}$	UNIT
			TYP	TYP	TYP	TYP	
t_{pd}	A	B	9.5	7.9	7.6	8.5	ns
	B	A	9.2	8.8	8.4	8	
t_{en}	OE	A	1	1	1	1	μs
		B	1	1	1	1	
t_{dis}	OE	A	20	17	17	18	ns
		B	20	16	15	15	
t_{rA} , t_{fA}	A-port rise and fall times		4.1	4.4	4.1	3.9	ns

Switching Characteristics: $V_{CCA} = 1.2\text{ V}$ (continued)
 $T_A = 25^\circ\text{C}$, $V_{CCA} = 1.2\text{ V}$

PARAMETER	FROM (INPUT)	TO (OUTPUT)	$V_{CCB} = 1.8\text{ V}$	$V_{CCB} = 2.5\text{ V}$	$V_{CCB} = 3.3\text{ V}$	$V_{CCB} = 5\text{ V}$	UNIT
			TYP	TYP	TYP	TYP	
t_{rB} , t_{fB}	B-port rise and fall times		5	5	5.1	5.1	ns
$t_{SK(O)}$	Channel-to-channel skew		2.4	1.7	1.9	7	ns
Max data rate			20	20	20	20	Mbps

6.12 Switching Characteristics: $V_{CCA} = 1.5\text{ V} \pm 0.1\text{ V}$

 over recommended operating free-air temperature range, $V_{CCA} = 1.5\text{ V} \pm 0.1\text{ V}$ (unless otherwise noted)

PARAMETER	FROM (INPUT)	TO (OUTPUT)	$V_{CCB} = 1.8\text{ V} \pm 0.15\text{ V}$		$V_{CCB} = 2.5\text{ V} \pm 0.2\text{ V}$		$V_{CCB} = 3.3\text{ V} \pm 0.3\text{ V}$		$V_{CCB} = 5\text{ V} \pm 0.5\text{ V}$		UNIT
			MIN	MAX	MIN	MAX	MIN	MAX	MIN	MAX	
t_{pd}	A	B	1.4	12.9	1.2	10.1	1.1	10	0.8	9.9	ns
	B	A	0.9	14.2	0.7	12	0.4	11.7	0.3	13.7	
t_{en}	OE	A		1		1		1		1	μs
		B		1		1		1		1	
t_{dis}	OE	A	6.6	33	6.4	25.3	6.1	23.1	5.9	24.6	ns
		B	6.6	35.6	5.8	25.6	5.5	22.1	5.6	20.6	
t_{rA} , t_{fA}	A-port rise and fall times		0.8	6.5	0.8	6.3	0.8	6.3	0.8	6.3	ns
t_{rB} , t_{fB}	B-port rise and fall times		1	7.3	0.7	4.9	0.7	4.6	0.6	4.6	ns
$t_{SK(O)}$	Channel-to-channel skew		2.6		1.9		1.6		1.3		ns
Max data rate			50		50		50		50		Mbps

6.13 Switching Characteristics: $V_{CCA} = 1.8\text{ V} \pm 0.15\text{ V}$

 over recommended operating free-air temperature range, $V_{CCA} = 1.8\text{ V} \pm 0.15\text{ V}$ (unless otherwise noted)

PARAMETER	FROM (INPUT)	TO (OUTPUT)	$V_{CCB} = 1.8\text{ V} \pm 0.15\text{ V}$		$V_{CCB} = 2.5\text{ V} \pm 0.2\text{ V}$		$V_{CCB} = 3.3\text{ V} \pm 0.3\text{ V}$		$V_{CCB} = 5\text{ V} \pm 0.5\text{ V}$		UNIT
			MIN	MAX	MIN	MAX	MIN	MAX	MIN	MAX	
t_{pd}	A	B	1.6	11	1.4	7.7	1.3	6.8	1.2	6.5	ns
	B	A	1.5	12	1.2	8.4	0.8	7.6	0.5	7.1	
t_{en}	OE	A		1		1		1		1	μs
		B		1		1		1		1	
t_{dis}	OE	A	5.9	26.7	5.6	21.6	5.4	18.9	4.8	18.7	ns
		B	6.1	33.9	5.2	23.7	5	19.9	5	17.6	
t_{rA} , t_{fA}	A-port rise and fall times		0.7	5.1	0.7	5	1	5	0.7	5	ns
t_{rB} , t_{fB}	B-port rise and fall times		1	7.3	0.7	5	0.7	3.9	0.6	3.8	ns
$t_{SK(O)}$	Channel-to-channel skew		0.8		0.7		0.6		0.6		ns
Max data rate			52		60		60		60		Mbps

6.14 Switching Characteristics: $V_{CCA} = 2.5 \text{ V} \pm 0.2 \text{ V}$

 over recommended operating free-air temperature range, $V_{CCA} = 2.5 \text{ V} \pm 0.2 \text{ V}$ (unless otherwise noted)

PARAMETER	FROM (INPUT)	TO (OUTPUT)	$V_{CCB} = 2.5 \text{ V} \pm 0.2 \text{ V}$		$V_{CCB} = 3.3 \text{ V} \pm 0.3 \text{ V}$		$V_{CCB} = 5 \text{ V} \pm 0.5 \text{ V}$		UNIT
			MIN	MAX	MIN	MAX	MIN	MAX	
t_{pd}	A	B	1.1	6.4	1	5.3	0.9	4.7	ns
	B	A	1	7	0.6	5.6	0.3	4.4	
t_{en}	OE	A	1		1		1		μs
		B	1		1		1		
t_{dis}	OE	A	5	16.9	4.9	15	4.5	13.8	ns
		B	4.8	21.8	4.5	17.9	4.4	15.2	
t_{rA}, t_{fA}	A-port rise and fall times		0.8	3.6	0.6	3.6	0.5	3.5	ns
t_{rB}, t_{fB}	B-port rise and fall times		0.6	4.9	0.7	3.9	0.6	3.2	ns
$t_{SK(O)}$	Channel-to-channel skew		0.4		0.3		0.3		ns
Max data rate			70		100		100		Mbps

6.15 Switching Characteristics: $V_{CCA} = 3.3 \text{ V} \pm 0.3 \text{ V}$

 over recommended operating free-air temperature range, $V_{CCA} = 3.3 \text{ V} \pm 0.3 \text{ V}$ (unless otherwise noted)

PARAMETER	FROM (INPUT)	TO (OUTPUT)	$V_{CCB} = 3.3 \text{ V} \pm 0.3 \text{ V}$		$V_{CCB} = 5 \text{ V} \pm 0.5 \text{ V}$		UNIT
			MIN	MAX	MIN	MAX	
t_{pd}	A	B	0.9	4.9	0.8	4	ns
	B	A	0.5	5.4	0.2	4	
t_{en}	OE	A	1		1		μs
		B	1		1		
t_{dis}	OE	A	4.5	13.9	4.1	12.4	ns
		B	4.1	17.3	4	14.4	
t_{rA}, t_{fA}	A-port rise and fall times		0.5	3	0.5	3	ns
t_{rB}, t_{fB}	B-port rise and fall times		0.7	3.9	0.6	3.2	ns
$t_{SK(O)}$	Channel-to-channel skew		0.4		0.3		ns
Max data rate			100		100		Mbps

6.16 Operating Characteristics

 $T_A = 25^\circ\text{C}$

PARAMETER	TEST CONDITIONS	V_{CCA}							UNIT	
		1.2 V	1.2 V	1.5 V	1.8 V	2.5 V	2.5 V	3.3 V		
		V_{CCB}								
		5 V	1.8 V	1.8 V	1.8 V	2.5 V	5 V	3.3 V to 5 V		
		TYP	TYP	TYP	TYP	TYP	TYP	TYP		
C_{pdA}	A-port input, B-port output	$C_L = 0, f = 10 \text{ MHz},$ $t_r = t_f = 1 \text{ ns},$ $OE = V_{CCA}$ (outputs enabled)	9	8	7	7	7	7	8	pF
	B-port input, A-port output		12	11	11	11	11	11	11	
C_{pdB}	A-port input, B-port output		35	26	27	27	27	27	28	
	B-port input, A-port output		26	19	18	18	18	20	21	
C_{pdA}	A-port input, B-port output	$C_L = 0, f = 10 \text{ MHz},$ $t_r = t_f = 1 \text{ ns},$ $OE = \text{GND}$ (outputs disabled)	0.01	0.01	0.01	0.01	0.01	0.01	0.01	pF
	B-port input, A-port output		0.01	0.01	0.01	0.01	0.01	0.01	0.01	
C_{pdB}	A-port input, B-port output		0.01	0.01	0.01	0.01	0.01	0.01	0.03	
	B-port input, A-port output		0.01	0.01	0.01	0.01	0.01	0.01	0.03	

6.17 Typical Characteristics

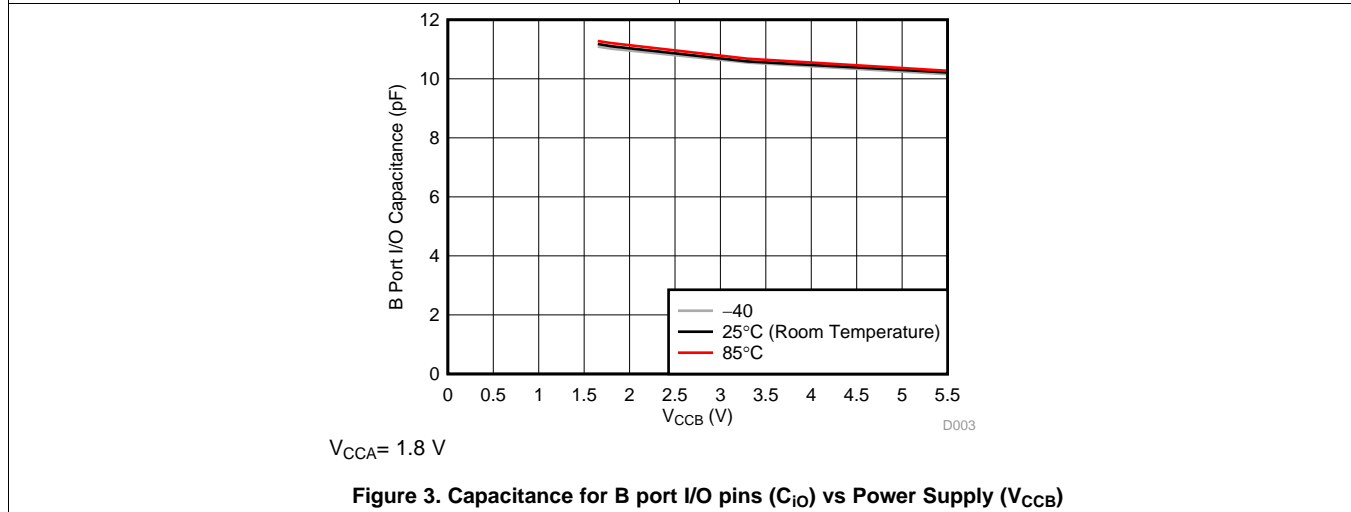
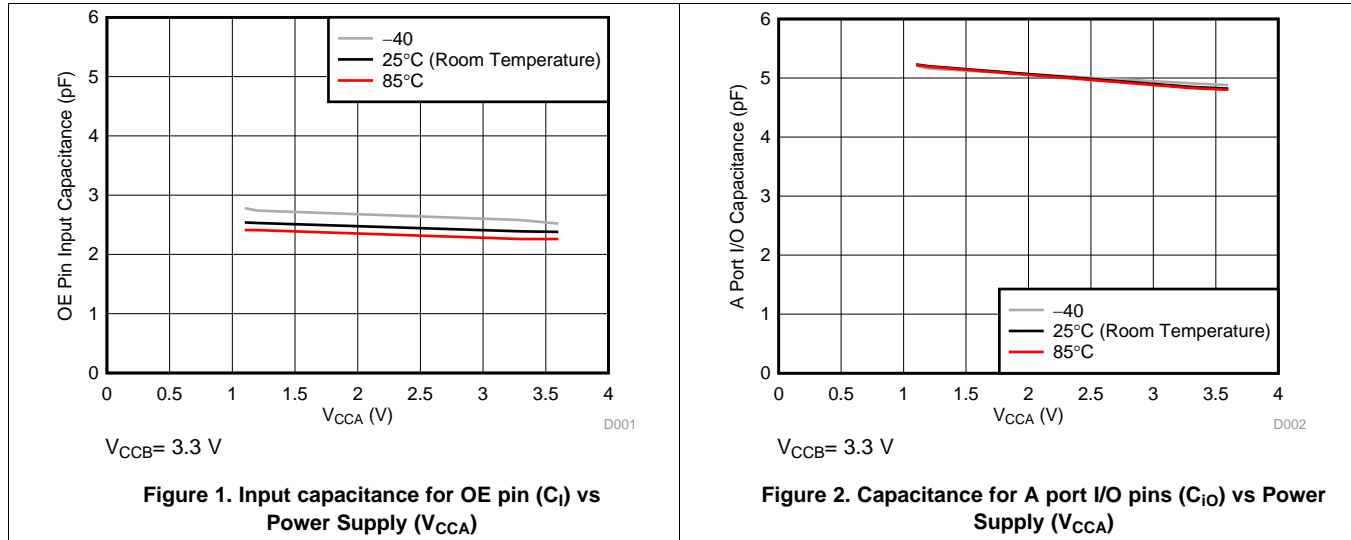

7 Parameter Measurement Information

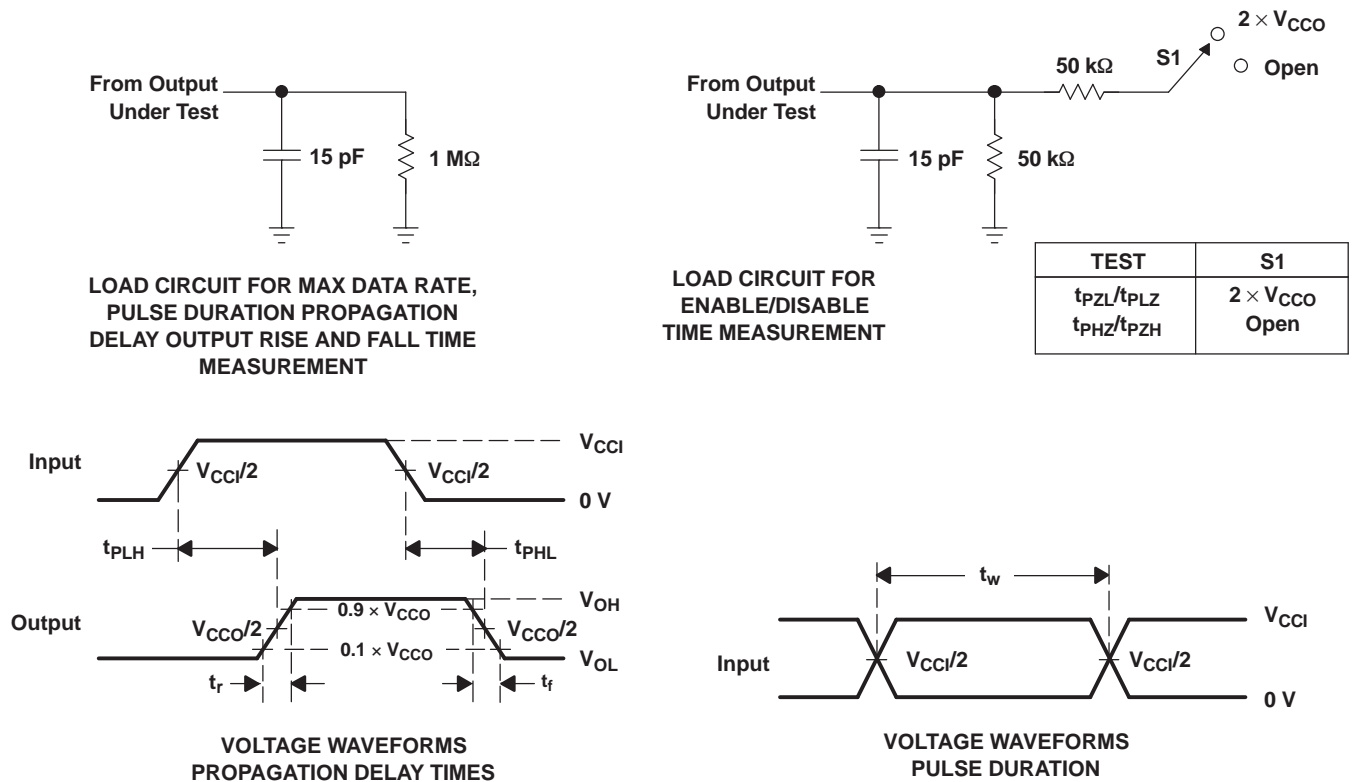

- A. C_L includes probe and jig capacitance.
- B. All input pulses are supplied by generators having the following characteristics: PRR ≤ 10 MHz, Z_O = 50 Ω, dv/dt ≥ 1 V/ns.
- C. The outputs are measured one at a time, with one transition per measurement.
- D. t_{PLH} and t_{PHL} are the same as t_{pd}.
- E. V_{CC1} is the V_{CC} associated with the input port.
- F. V_{CCO} is the V_{CC} associated with the output port.
- G. All parameters and waveforms are not applicable to all devices.

Figure 4. Load Circuits and Voltage Waveforms

8 Detailed Description

8.1 Overview

The TXB0106 device is a 6-bit, directionless voltage-level translator specifically designed for translating logic voltage levels. The A port is able to accept I/O voltages ranging from 1.2 V to 3.6 V, while the B port can accept I/O voltages from 1.65 V to 5.5 V. The device is a buffered architecture with edge-rate accelerators (one-shots) to improve the overall data rate. This device can only translate push-pull CMOS logic outputs. If for open-drain signal translation, please refer to TI's TXS010X products.

8.2 Functional Block Diagram

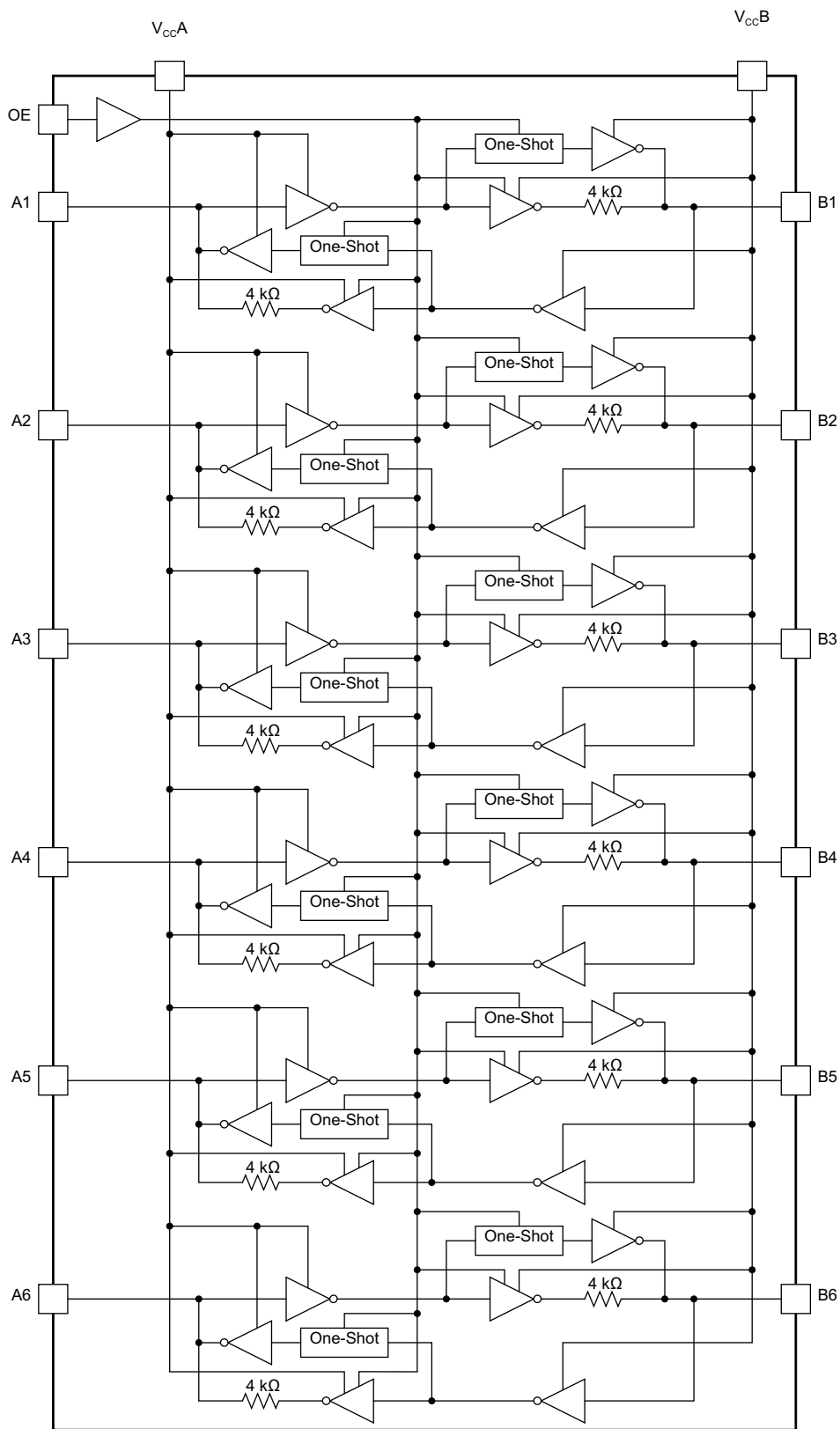

8.3 Feature Description

8.3.1 Architecture

The TXB0106 architecture (see [Figure 5](#)) does not require a direction-control signal to control the direction of data flow from A to B or from B to A. In a dc state, the output drivers of the TXB0106 can maintain a high or low, but are designed to be weak, so that they can be overdriven by an external driver when data on the bus starts flowing the opposite direction.

The output one-shots detect rising or falling edges on the A or B ports. During a rising edge, the one-shot turns on the PMOS transistors (T1, T3) for a short duration, which speeds up the low-to-high transition. Similarly, during a falling edge, the one-shot turns on the NMOS transistors (T2, T4) for a short duration, which speeds up the high-to-low transition. The typical output impedance during output transition is 70 Ω at $V_{CCO} = 1.2\text{ V}$ to 1.8 V, 50 Ω at $V_{CCO} = 1.8\text{ V}$ to 3.3 V, and 40 Ω at $V_{CCO} = 3.3\text{ V}$ to 5 V.

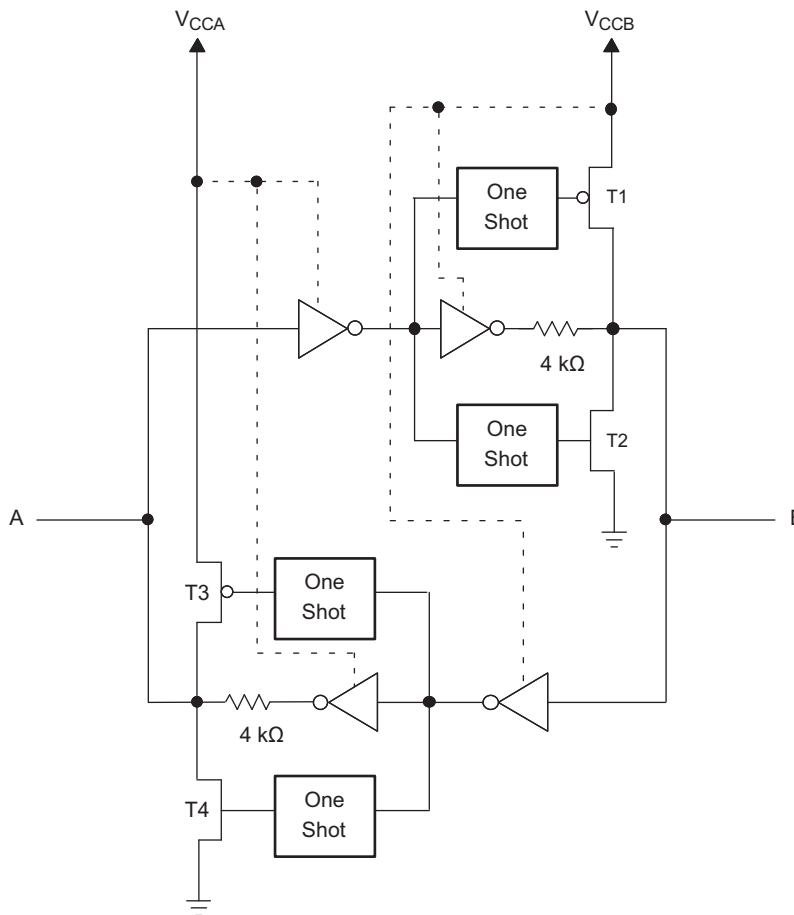
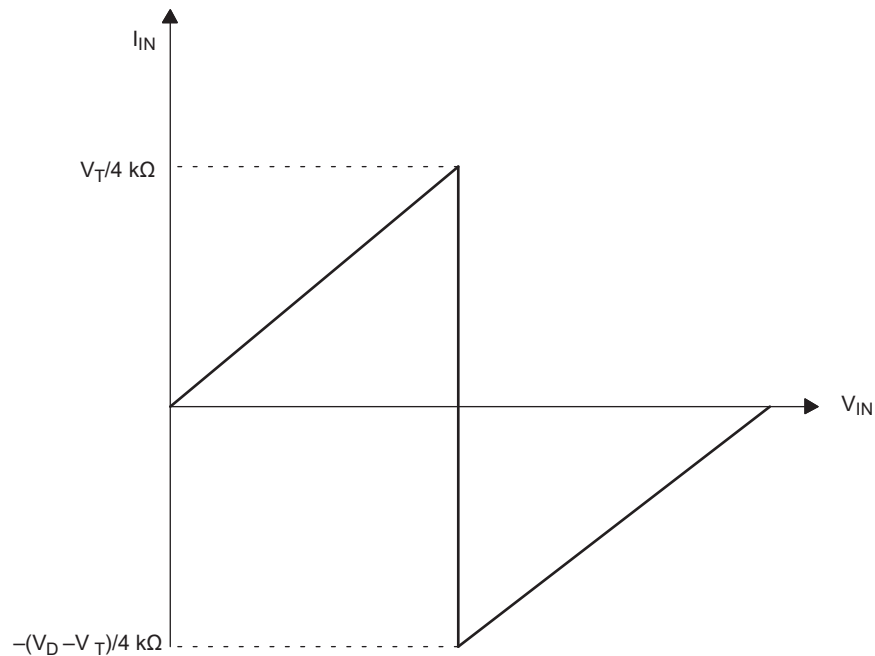

Figure 5. Architecture of TXB0106 I/O Cell

8.3.2 Input Driver Requirements

Typical I_{IN} vs V_{IN} characteristics of the TXB0106 are shown in [Figure 6](#). For proper operation, the device driving the data I/Os of the TXB0106 must have drive strength of at least $\pm 2\text{ mA}$.

Feature Description (continued)



- A. V_T is the input threshold voltage of the TXB0106 (typically $V_{CCI}/2$).
- B. V_D is the supply voltage of the external driver.

Figure 6. Typical I_{IN} vs V_{IN} Curve

8.3.3 Power Up

During operation, ensure that $V_{CCA} \leq V_{CCB}$ at all times. During power-up sequencing, $V_{CCA} \geq V_{CCB}$ does not damage the device, so any power supply can be ramped up first. The TXB0106 has circuitry that disables all output ports when either V_{CC} is switched off ($V_{CCA/B} = 0$ V).

8.3.4 Output Load Considerations

TI recommends careful PCB layout practices with short PCB trace lengths to avoid excessive capacitive loading and to ensure that proper O.S. triggering takes place. PCB signal trace-lengths should be kept short enough such that the round trip delay of any reflection is less than the one-shot duration. This improves signal integrity by ensuring that any reflection sees a low impedance at the driver. The O.S. circuits have been designed to stay on for approximately 10 ns. The maximum capacitance of the lumped load that can be driven also depends directly on the one-shot duration. With very heavy capacitive loads, the one-shot can time-out before the signal is driven fully to the positive rail. The O.S. duration has been set to best optimize trade-offs between dynamic ICC, load driving capability, and maximum bit-rate considerations. Both PCB trace length and connectors add to the capacitance that the TXB0106 output sees, so it is recommended that this lumped-load capacitance be considered to avoid O.S. retriggering, bus contention, output signal oscillations, or other adverse system-level affects.

8.3.5 Enable and Disable

The TXB0106 has an OE input that is used to disable the device by setting OE = low, which places all I/Os in the high-impedance (Hi-Z) state. The disable time (t_{dis}) indicates the delay between when OE goes low and when the outputs actually get disabled (Hi-Z). The enable time (t_{en}) indicates the amount of time the user must allow for the one-shot circuitry to become operational after OE is taken high.

Feature Description (continued)

8.3.6 Pullup or Pulldown Resistors on I/O Lines

The TXB0106 is designed to drive capacitive loads of up to 70 pF. The output drivers of the TXB0106 have low dc drive strength. If pullup or pulldown resistors are connected externally to the data I/Os, their values must be kept higher than 50 k Ω to ensure that they do not contend with the output drivers of the TXB0106.

For the same reason, the TXB0106 should not be used in applications such as I²C or 1-Wire where an open-drain driver is connected on the bidirectional data I/O. For these applications, use a device from the TI TXS01xx series of level translators.

8.3.7 Device Functional Modes

The TXB0106 device has two functional modes, enabled and disabled. To disable the device, set the OE input to low, which places all I/Os in a high impedance state. Setting the OE input to high will enable the device.

9 Application and Implementation

NOTE

Information in the following applications sections is not part of the TI component specification, and TI does not warrant its accuracy or completeness. TI's customers are responsible for determining suitability of components for their purposes. Customers should validate and test their design implementation to confirm system functionality.

9.1 Application Information

The TXB0106 can be used in level-translation applications for interfacing devices or systems operating at different interface voltages with one another. It can only translate push-pull CMOS logic outputs. If for open-drain signal translation, please refer to TI TXS010X products. Any external pulldown or pullup resistors are recommended larger than 50 kΩ.

9.2 Typical Application

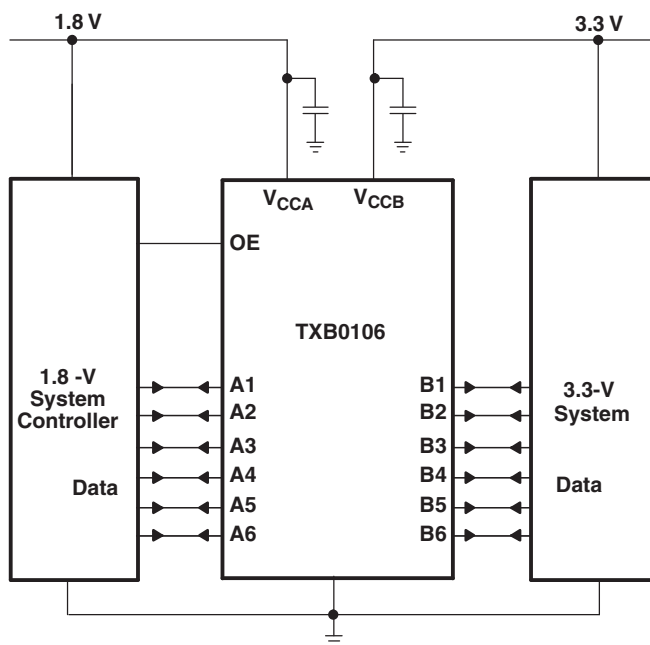

Figure 7. Typical Operating Circuit

9.2.1 Design Requirements

For this design example, use the parameters listed in Table 1. And make sure that $V_{CCA} \leq V_{CCB}$.

Table 1. Design Parameters

DESIGN PARAMETERS	EXAMPLE VALUE
Input voltage range	1.2 V to 3.6 V
Output voltage range	1.65 V to 5.5 V

9.2.2 Detailed Design Procedure

To begin the design process, determine the following:

- Input voltage range
 - Use the supply voltage of the device that is driving the TXB0106 device to determine the input voltage range. For a valid logic high the value must exceed the V_{IH} of the input port. For a valid logic low the value must be less than the V_{IL} of the input port.

- Output voltage range
 - Use the supply voltage of the device that the TXB0106 device is driving to determine the output voltage range.
 - Don't recommend to have the external pullup or pulldown resistors. If mandatory, it is recommended the value should be larger than 50 kΩ.

• An external pulldown or pullup resistor decreases the output V_{OH} and V_{OL} . Use the below equations to draft estimate the V_{OH} and V_{OL} as a result of an external pulldown and pullup resistor.

$$V_{OH} = V_{CCx} \times R_{PD} / (R_{PD} + 4.5 \text{ k}\Omega)$$

$$V_{OL} = V_{CCx} \times 4.5 \text{ k}\Omega / (R_{PU} + 4.5 \text{ k}\Omega)$$

Where

- V_{CCx} is the output port supply voltage on either V_{CCA} or V_{CCB}
- R_{PD} is the value of the external pull down resistor
- R_{PU} is the value of the external pull up resistor
- 4.5 kΩ is the counting the variation of the serial resistor 4 kΩ in the I/O line.

9.2.3 Application Curves

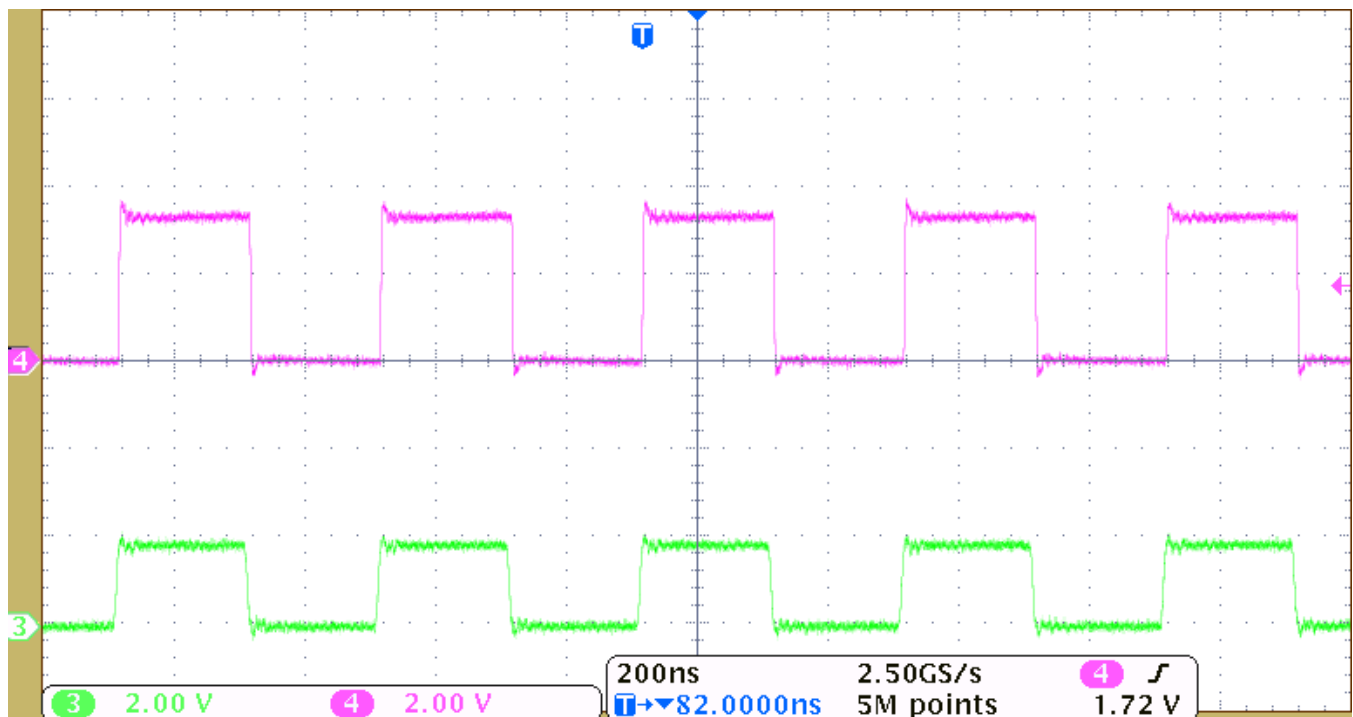

Figure 8. Level-Translation of a 2.5-MHz Signal

10 Power Supply Recommendations

During operation, ensure that $V_{CCA} \leq V_{CCB}$ at all times. During power-up sequencing, $V_{CCA} \geq V_{CCB}$ does not damage the device, so any power supply can be ramped up first. The TXB0106 has circuitry that disables all output ports when either V_{CC} is switched off ($V_{CCA/B} = 0 \text{ V}$). The output-enable (OE) input circuit is designed so that it is supplied by V_{CCA} and when the (OE) input is low, all outputs are placed in the high-impedance state. To ensure the high-impedance state of the outputs during power up or power down, the OE input pin must be tied to GND through a pulldown resistor and must not be enabled until V_{CCA} and V_{CCB} are fully ramped and stable. The minimum value of the pulldown resistor to ground is determined by the current-sourcing capability of the driver.

11 Layout

11.1 Layout Guidelines

To ensure reliability of the device, following common printed-circuit board layout guidelines is recommended.

- Bypass capacitors should be used on power supplies. And should be placed as close as possible to the V_{CCA} , V_{CCB} pin and GND pin
- Short trace-lengths should be used to avoid excessive loading.
- PCB signal trace-lengths must be kept short enough so that the round-trip delay of any reflection is less than the one-shot duration, approximately 10 ns, ensuring that any reflection encounters low impedance at the source driver.

11.2 Layout Example

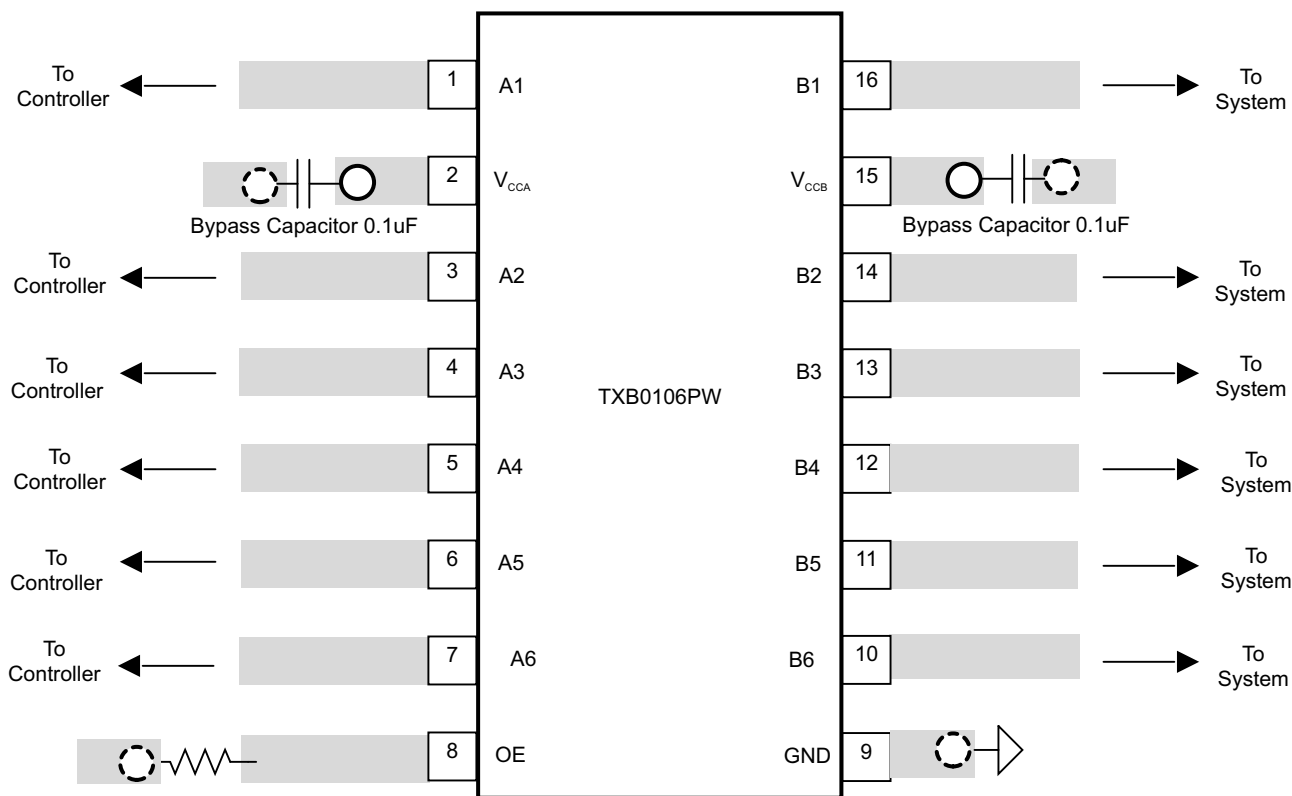
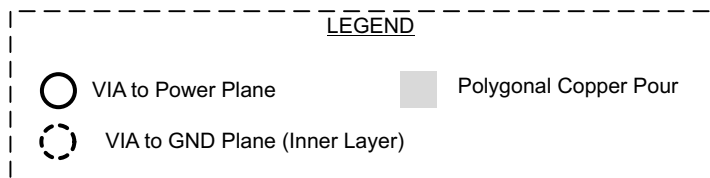

Keep OE low until V_{CCA} and V_{CCB} are powered up

12 Device and Documentation Support

12.1 Documentation Support

For related documentation see the following:

A Guide to Voltage Translation With TXB-Type Translators, [SCEA043](#)

12.2 Community Resources

The following links connect to TI community resources. Linked contents are provided "AS IS" by the respective contributors. They do not constitute TI specifications and do not necessarily reflect TI's views; see TI's [Terms of Use](#).

TI E2E™ Online Community *TI's Engineer-to-Engineer (E2E) Community*. Created to foster collaboration among engineers. At [e2e.ti.com](#), you can ask questions, share knowledge, explore ideas and help solve problems with fellow engineers.

Design Support *TI's Design Support* Quickly find helpful E2E forums along with design support tools and contact information for technical support.

12.3 Trademarks

E2E is a trademark of Texas Instruments.
All other trademarks are the property of their respective owners.

12.4 Electrostatic Discharge Caution



These devices have limited built-in ESD protection. The leads should be shorted together or the device placed in conductive foam during storage or handling to prevent electrostatic damage to the MOS gates.

12.5 Glossary

[SLYZ022](#) — *TI Glossary*.

This glossary lists and explains terms, acronyms, and definitions.

13 Mechanical, Packaging, and Orderable Information

The following pages include mechanical, packaging, and orderable information. This information is the most current data available for the designated devices. This data is subject to change without notice and revision of this document. For browser-based versions of this data sheet, refer to the left-hand navigation.

PACKAGING INFORMATION

Orderable Device	Status (1)	Package Type	Package Drawing	Pins	Package Qty	Eco Plan (2)	Lead finish/ Ball material (6)	MSL Peak Temp (3)	Op Temp (°C)	Device Marking (4/5)	Samples
TXB0106PWR	ACTIVE	TSSOP	PW	16	2000	RoHS & Green	NIPDAU	Level-1-260C-UNLIM	-40 to 85	YE06	Samples
TXB0106RGYR	ACTIVE	VQFN	RGY	16	3000	RoHS & Green	NIPDAU	Level-2-260C-1 YEAR	-40 to 85	YE06	Samples

(1) The marketing status values are defined as follows:

ACTIVE: Product device recommended for new designs.

LIFEBUY: TI has announced that the device will be discontinued, and a lifetime-buy period is in effect.

NRND: Not recommended for new designs. Device is in production to support existing customers, but TI does not recommend using this part in a new design.

PREVIEW: Device has been announced but is not in production. Samples may or may not be available.

OBSOLETE: TI has discontinued the production of the device.

(2) **RoHS:** TI defines "RoHS" to mean semiconductor products that are compliant with the current EU RoHS requirements for all 10 RoHS substances, including the requirement that RoHS substance do not exceed 0.1% by weight in homogeneous materials. Where designed to be soldered at high temperatures, "RoHS" products are suitable for use in specified lead-free processes. TI may reference these types of products as "Pb-Free".

RoHS Exempt: TI defines "RoHS Exempt" to mean products that contain lead but are compliant with EU RoHS pursuant to a specific EU RoHS exemption.

Green: TI defines "Green" to mean the content of Chlorine (Cl) and Bromine (Br) based flame retardants meet JS709B low halogen requirements of <=1000ppm threshold. Antimony trioxide based flame retardants must also meet the <=1000ppm threshold requirement.

(3) MSL, Peak Temp. - The Moisture Sensitivity Level rating according to the JEDEC industry standard classifications, and peak solder temperature.

(4) There may be additional marking, which relates to the logo, the lot trace code information, or the environmental category on the device.

(5) Multiple Device Markings will be inside parentheses. Only one Device Marking contained in parentheses and separated by a "~" will appear on a device. If a line is indented then it is a continuation of the previous line and the two combined represent the entire Device Marking for that device.

(6) Lead finish/Ball material - Orderable Devices may have multiple material finish options. Finish options are separated by a vertical ruled line. Lead finish/Ball material values may wrap to two lines if the finish value exceeds the maximum column width.

Important Information and Disclaimer:The information provided on this page represents TI's knowledge and belief as of the date that it is provided. TI bases its knowledge and belief on information provided by third parties, and makes no representation or warranty as to the accuracy of such information. Efforts are underway to better integrate information from third parties. TI has taken and continues to take reasonable steps to provide representative and accurate information but may not have conducted destructive testing or chemical analysis on incoming materials and chemicals. TI and TI suppliers consider certain information to be proprietary, and thus CAS numbers and other limited information may not be available for release.

In no event shall TI's liability arising out of such information exceed the total purchase price of the TI part(s) at issue in this document sold by TI to Customer on an annual basis.

OTHER QUALIFIED VERSIONS OF TXB0106 :

- Automotive: [TXB0106-Q1](#)

NOTE: Qualified Version Definitions:

- Automotive - Q100 devices qualified for high-reliability automotive applications targeting zero defects

TAPE AND REEL INFORMATION

QUADRANT ASSIGNMENTS FOR PIN 1 ORIENTATION IN TAPE

*All dimensions are nominal

Device	Package Type	Package Drawing	Pins	SPQ	Reel Diameter (mm)	Reel Width W1 (mm)	A0 (mm)	B0 (mm)	K0 (mm)	P1 (mm)	W (mm)	Pin1 Quadrant
TXB0106PWR	TSSOP	PW	16	2000	330.0	12.4	6.9	5.6	1.6	8.0	12.0	Q1
TXB0106RGYR	VQFN	RGY	16	3000	330.0	12.4	3.8	4.3	1.5	8.0	12.0	Q1

TAPE AND REEL BOX DIMENSIONS

*All dimensions are nominal

Device	Package Type	Package Drawing	Pins	SPQ	Length (mm)	Width (mm)	Height (mm)
TXB0106PWR	TSSOP	PW	16	2000	853.0	449.0	35.0
TXB0106RGYR	VQFN	RGY	16	3000	853.0	449.0	35.0



4220204/A 02/2017

NOTES:

1. All linear dimensions are in millimeters. Any dimensions in parenthesis are for reference only. Dimensioning and tolerancing per ASME Y14.5M.
2. This drawing is subject to change without notice.
3. This dimension does not include mold flash, protrusions, or gate burrs. Mold flash, protrusions, or gate burrs shall not exceed 0.15 mm per side.
4. This dimension does not include interlead flash. Interlead flash shall not exceed 0.25 mm per side.
5. Reference JEDEC registration MO-153.

EXAMPLE BOARD LAYOUT

PW0016A

TSSOP - 1.2 mm max height

SMALL OUTLINE PACKAGE



LAND PATTERN EXAMPLE
EXPOSED METAL SHOWN
SCALE: 10X



SOLDER MASK DETAILS

4220204/A 02/2017

NOTES: (continued)

- 6. Publication IPC-7351 may have alternate designs.
- 7. Solder mask tolerances between and around signal pads can vary based on board fabrication site.

EXAMPLE STENCIL DESIGN

PW0016A

TSSOP - 1.2 mm max height

SMALL OUTLINE PACKAGE



SOLDER PASTE EXAMPLE
BASED ON 0.125 mm THICK STENCIL
SCALE: 10X

4220204/A 02/2017

NOTES: (continued)

8. Laser cutting apertures with trapezoidal walls and rounded corners may offer better paste release. IPC-7525 may have alternate design recommendations.
9. Board assembly site may have different recommendations for stencil design.

RGY (R-PVQFN-N16)

PLASTIC QUAD FLATPACK NO-LEAD

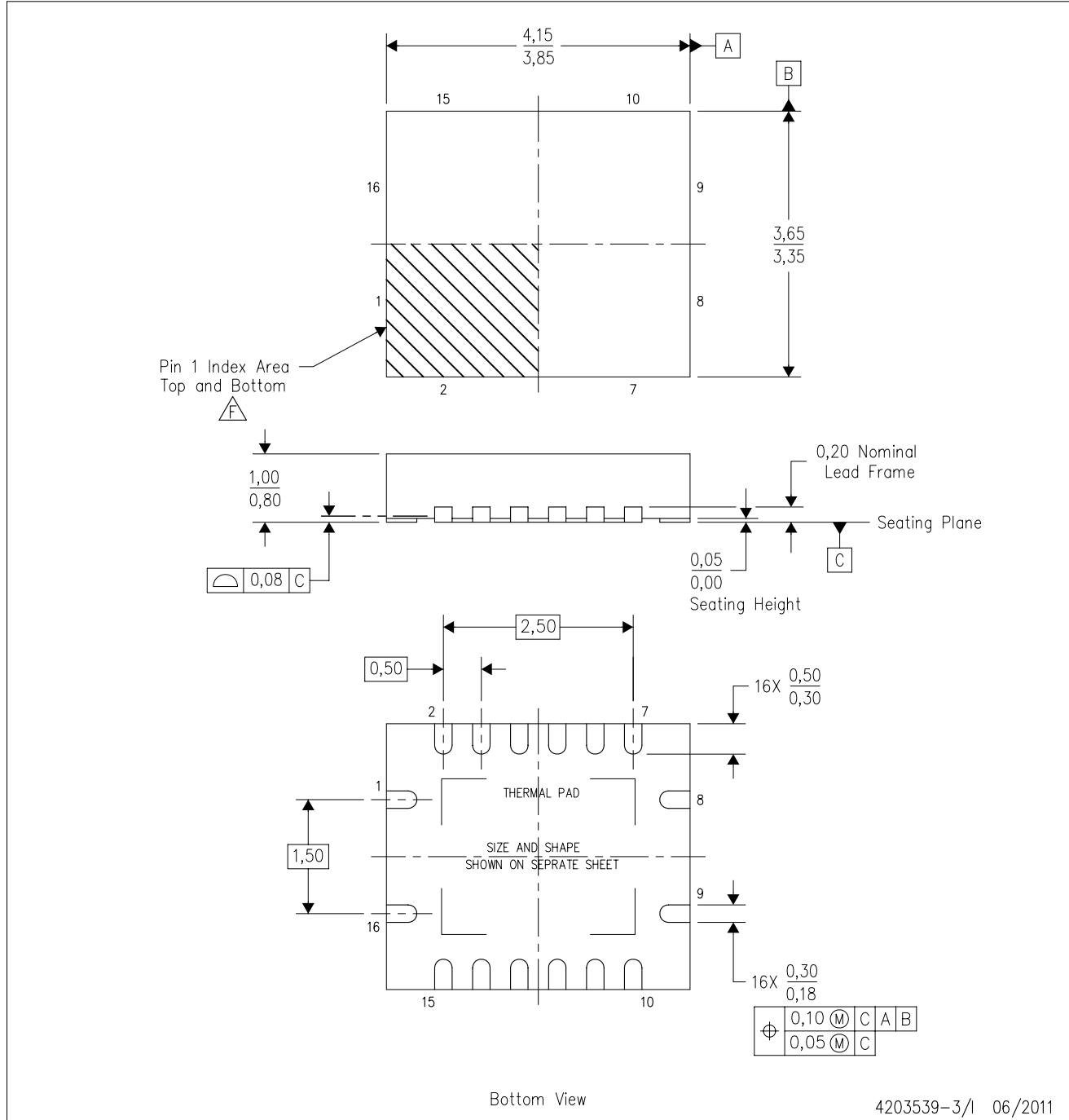

- NOTES:
- A. All linear dimensions are in millimeters. Dimensioning and tolerancing per ASME Y14.5M-1994.
 - B. This drawing is subject to change without notice.
 - C. QFN (Quad Flatpack No-Lead) package configuration.
 - D. The package thermal pad must be soldered to the board for thermal and mechanical performance.
 - E. See the additional figure in the Product Data Sheet for details regarding the exposed thermal pad features and dimensions.
 - F. Pin 1 identifiers are located on both top and bottom of the package and within the zone indicated. The Pin 1 identifiers are either a molded, marked, or metal feature.
 - G. Package complies to JEDEC MO-241 variation BA.

RGY (R-PVQFN-N16)

PLASTIC QUAD FLATPACK NO-LEAD

THERMAL INFORMATION

This package incorporates an exposed thermal pad that is designed to be attached directly to an external heatsink. The thermal pad must be soldered directly to the printed circuit board (PCB). After soldering, the PCB can be used as a heatsink. In addition, through the use of thermal vias, the thermal pad can be attached directly to the appropriate copper plane shown in the electrical schematic for the device, or alternatively, can be attached to a special heatsink structure designed into the PCB. This design optimizes the heat transfer from the integrated circuit (IC).

For information on the Quad Flatpack No-Lead (QFN) package and its advantages, refer to Application Report, QFN/SON PCB Attachment, Texas Instruments Literature No. SLUA271. This document is available at www.ti.com.

The exposed thermal pad dimensions for this package are shown in the following illustration.



Bottom View

Exposed Thermal Pad Dimensions

4206353-3/P 03/14

NOTE: All linear dimensions are in millimeters

RGY (R-PVQFN-N16)

PLASTIC QUAD FLATPACK NO-LEAD



- NOTES:
- A. All linear dimensions are in millimeters.
 - B. This drawing is subject to change without notice.
 - C. Publication IPC-7351 is recommended for alternate designs.
 - D. This package is designed to be soldered to a thermal pad on the board. Refer to Application Note, Quad Flat-Pack QFN/SON PCB Attachment, Texas Instruments Literature No. SLUA271, and also the Product Data Sheets for specific thermal information, via requirements, and recommended board layout. These documents are available at www.ti.com <<http://www.ti.com>>.
 - E. Laser cutting apertures with trapezoidal walls and also rounding corners will offer better paste release. Customers should contact their board assembly site for stencil design recommendations. Refer to IPC 7525 for stencil design considerations.
 - F. Customers should contact their board fabrication site for minimum solder mask web tolerances between signal pads.

IMPORTANT NOTICE AND DISCLAIMER

TI PROVIDES TECHNICAL AND RELIABILITY DATA (INCLUDING DATASHEETS), DESIGN RESOURCES (INCLUDING REFERENCE DESIGNS), APPLICATION OR OTHER DESIGN ADVICE, WEB TOOLS, SAFETY INFORMATION, AND OTHER RESOURCES "AS IS" AND WITH ALL FAULTS, AND DISCLAIMS ALL WARRANTIES, EXPRESS AND IMPLIED, INCLUDING WITHOUT LIMITATION ANY IMPLIED WARRANTIES OF MERCHANTABILITY, FITNESS FOR A PARTICULAR PURPOSE OR NON-INFRINGEMENT OF THIRD PARTY INTELLECTUAL PROPERTY RIGHTS.

These resources are intended for skilled developers designing with TI products. You are solely responsible for (1) selecting the appropriate TI products for your application, (2) designing, validating and testing your application, and (3) ensuring your application meets applicable standards, and any other safety, security, or other requirements. These resources are subject to change without notice. TI grants you permission to use these resources only for development of an application that uses the TI products described in the resource. Other reproduction and display of these resources is prohibited. No license is granted to any other TI intellectual property right or to any third party intellectual property right. TI disclaims responsibility for, and you will fully indemnify TI and its representatives against, any claims, damages, costs, losses, and liabilities arising out of your use of these resources.

TI's products are provided subject to TI's Terms of Sale (www.ti.com/legal/termsofsale.html) or other applicable terms available either on ti.com or provided in conjunction with such TI products. TI's provision of these resources does not expand or otherwise alter TI's applicable warranties or warranty disclaimers for TI products.

Mailing Address: Texas Instruments, Post Office Box 655303, Dallas, Texas 75265
Copyright © 2020, Texas Instruments Incorporated