

5-V Dual Differential PECL Buffer-to-TTL Translator

FEATURES

- Dual 5-V Differential PECL-to-TTL Buffer
- 24-mA TTL Outputs
- Operating Range
 - PECL $V_{CC} = 4.75\text{ V to }5.25\text{ V}$ with $GND = 0\text{ V}$
- Support for Clock Frequencies of 250 MHz (TYP)
- 3.5-ns Typical Propagation Delay
- Output Default Low with Inputs Left Open or $<1.3\text{ V}$
- Internal Input 50-k Ω Pull-Down Resistor
- Built-In Temperature Compensation
- Drop-In Compatible to the MC100ELT23

APPLICATIONS

- Data and Clock Transmission Over Backplane
- Signaling Level Conversion for Clock or Data

DESCRIPTION

The SN65ELT23 is a low power dual PECL-to-TTL translator device. The device includes circuitry to maintain a known logic low level when inputs are in an open condition. The SN65ELT23 is housed in an industry standard SOIC-8 package and is also available in an optional TSSOP-8 package.

PIN ASSIGNMENT

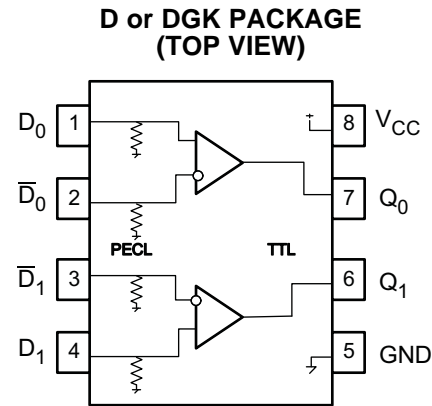

Table 1. Pin Descriptions

PIN	FUNCTION
$D_0, \bar{D}_0, D_1, \bar{D}_1$	PECL inputs
Q_0, Q_1	TTL outputs
V_{CC}	Positive supply
GND	Ground

ORDERING INFORMATION⁽¹⁾⁽²⁾

PART NUMBER	PART MARKING	PACKAGE	LEAD FINISH
SN65ELT23D	ELT23	SOIC	NiPdAu
SN65ELT23DGK	SIKI	MSOP	NiPdAu

(1) For the most current package and ordering information, see the Package Option Addendum at the end of this document, or see the TI web site at www.ti.com.

(2) Leaded device options are not initially available; contact a sales representative for further details.



Please be aware that an important notice concerning availability, standard warranty, and use in critical applications of Texas Instruments semiconductor products and disclaimers thereto appears at the end of this data sheet.



These devices have limited built-in ESD protection. The leads should be shorted together or the device placed in conductive foam during storage or handling to prevent electrostatic damage to the MOS gates.

ABSOLUTE MAXIMUM RATINGS⁽¹⁾

PARAMETER	CONDITIONS	VALUE	UNIT
Absolute supply voltage, V_{CC}		6	V
Absolute input voltage, V_I	$GND = 0$ and $V_I \leq V_{CC}$	0 to 6	V
Output current	Continuous	50	mA
	Surge	100	
Operating temperature range		–40 to 85	°C
Storage temperature range		–65 to 150	°C

(1) Stresses beyond those listed under absolute maximum ratings may cause permanent damage to the device. These are stress ratings only and functional operation of the device at these or any conditions beyond those indicated under recommended operating conditions is not implied. Exposure to absolute-maximum-rated conditions for extended periods may affect device reliability.

DISSIPATION RATINGS

PACKAGE	CIRCUIT BOARD MODEL	POWER RATING $T_A < 25^\circ\text{C}$ (mW)	THERMAL RESISTANCE, JUNCTION-TO-AMBIENT NO AIRFLOW	DERATING FACTOR $T_A > 25^\circ\text{C}$ (mW/°C)	POWER RATING $T_A = 85^\circ\text{C}$ (mW)
SOIC	Low-K	719	139	7	288
	High-K	840	119	8	336
MSOP	Low-K	469	213	5	188
	High-K	527	189	5	211

THERMAL CHARACTERISTICS

over operating free-air temperature range (unless otherwise noted)

PARAMETER		MIN	TYP	MAX	UNIT
θ_{JB}	Junction-to-board thermal resistance	SOIC	79		°C/W
		MSOP	120		
θ_{JC}	Junction-to-case thermal resistance	SOIC	98		°C/W
		MSOP	74		

KEY ATTRIBUTES

CHARACTERISTICS	PARAMETER	VALUE
Moisture sensitivity level		Level 1
Flammability rating (oxygen index: 28 to 34)		UL 94 V-0 at 0.125 in
Internal pull down resistor		50 K Ω
Electrostatic discharge	Human body model	2 KV
	Charged-device model	1.5 KV
	Machine model	200 V
Meets or exceeds JEDEC Spec EIA/JESD78 latchup test		

PECL INPUT DC CHARACTERISTICS

At $V_{CC} = 5.0\text{ V}$, $GND = 0.0\text{ V}$ (unless otherwise noted)⁽¹⁾⁽²⁾

PARAMETER	TEST CONDITIONS	$T_A = -40^\circ\text{C}$			$T_A = 25^\circ\text{C}$			$T_A = 85^\circ\text{C}$			UNIT
		MIN	TYP	MAX	MIN	TYP	MAX	MIN	TYP	MAX	
V_{IH}	High-level input voltage, single-ended	See ⁽³⁾			3835	4120	3835	4120	3835	4120	mV
V_{IL}	Low-level input voltage, single-ended	3190	2280	3525	3190	2280	3525	3190	2280	3525	mV
V_{IHCMR}	High-level input voltage common-mode range, differential	See ⁽⁴⁾			2.2	5.0	2.2	5.0	2.2	5.0	V
I_{IH}	High-level input current				255			175			μA
I_{IL}	Low-level input current	0.5			0.5			0.5			μA

- (1) The device meets the specifications after thermal balance has been established when mounted in a socket or printed circuit board with maintained transverse airflow greater than 500 lfm. Electrical parameters are assured only over the declared operating temperature range. Functional operation of the device exceeding these conditions is not implied. Device specification limit values are applied individually under normal operating conditions and not valid simultaneously.
- (2) Input and output parameters vary 1:1 with V_{CC} . V_{CC} can vary $\pm 0.25\text{ V}$.
- (3) TTL output $R_L = 500\ \Omega$ to GND
- (4) $V_{IHCMR(\min)}$ varies 1:1 with GND, $V_{IHCMR(\max)}$ varies 1:1 with V_{CC} .

TTL OUTPUT DC CHARACTERISTICS

At $V_{CC} = 4.75\text{ V}$ to 5.25 V , $T_A = -40^\circ\text{C}$ to 85°C (unless otherwise noted)⁽¹⁾

PARAMETER	TEST CONDITIONS	MIN	TYP	MAX	UNIT
I_{CCH}	Power supply current		20	25	mA
I_{CCL}	Power supply current		21	27	mA
I_{OS}	Output short circuit current	-150		-50	mA
V_{OH}	High-level output voltage ⁽²⁾	$I_{OH} = -3.0\text{ mA}$		$V_{CC} - 0.7\text{ V}$	V
V_{OL}	Low-level output voltage	$I_{OL} = 24\text{ mA}$		0.5	V

- (1) The device meets the specifications after thermal balance has been established when mounted in a socket or printed circuit board with maintained transverse airflow greater than 500 lfm. Electrical parameters are assured only over the declared operating temperature range. Functional operation of the device exceeding these conditions is not implied. Device specification limit values are applied individually under normal operating conditions and not valid simultaneously.
- (2) Max level is assured by design

AC CHARACTERISTICS

At $V_{CC} = 5.0\text{ V}$, $GND = 0.0\text{ V}$ (unless otherwise noted)⁽¹⁾⁽²⁾⁽³⁾

PARAMETER	TEST CONDITIONS	$T_A = -40^\circ\text{C}$			$T_A = 25^\circ\text{C}$			$T_A = 85^\circ\text{C}$			UNIT	
		MIN	TYP	MAX	MIN	TYP	MAX	MIN	TYP	MAX		
f_{MAX}	Max switching frequency	at $V_{ol} < 0.5\text{ V}$ and $V_{oh} > 2.4\text{ V}$ (see Figure 5)			250			250			MHz	
$t_{\text{PLH}}/t_{\text{PHL}}$	Propagation delay times to output	2.0	3.5	5.0	2.0	3.7	5.0	2.0	3.9	5.0	ns	
t_{JITTER}	Random clock jitter (RMS)	4.1			10			3.7			10	ps
V_{PP}	Input voltage swing ⁽⁴⁾	200			1000			200			1000	mV
t_r/t_f	Output rise times (10%–90%)	1.0	1.7	3.0	1.0	1.8	3.0	1.0	1.9	3.0	ns	
	Output fall times (10%–90%)	0.5	1.0	1.6	0.5	1.1	1.6	0.5	1.3	1.6		

- (1) The device meets the specifications after thermal balance has been established when mounted in a socket or printed circuit board with maintained transverse airflow greater than 500 lfm. Electrical parameters are assured only over the declared operating temperature range. Functional operation of the device exceeding these conditions is not implied. Device specification limit values are applied individually under normal operating conditions and not valid simultaneously.
- (2) V_{CC} can vary $\pm 0.25\text{ V}$.
- (3) TTL output $R_L = 500\ \Omega$ to GND and $C_L = 20\text{ pF}$ to GND, see [Figure 1](#).
- (4) $V_{\text{PP}(\min)}$ is the minimum input swing for which AC parameters are assured.

Typical Output Loading Used for Device Evaluation

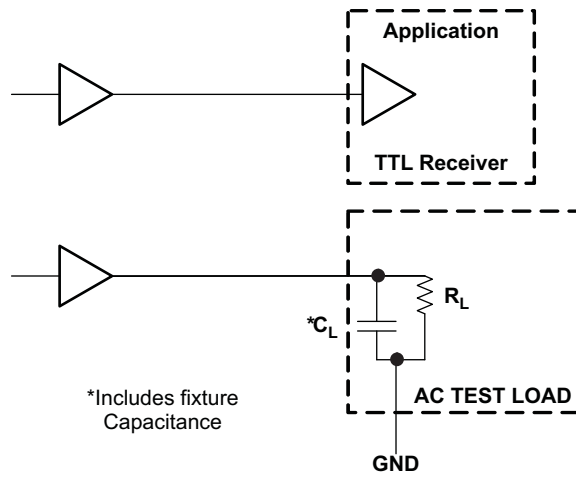

Figure 1. TTL Output Loading Used for Device Evaluation

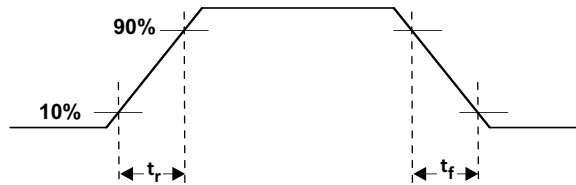

Figure 2. Output Rise and Fall Times

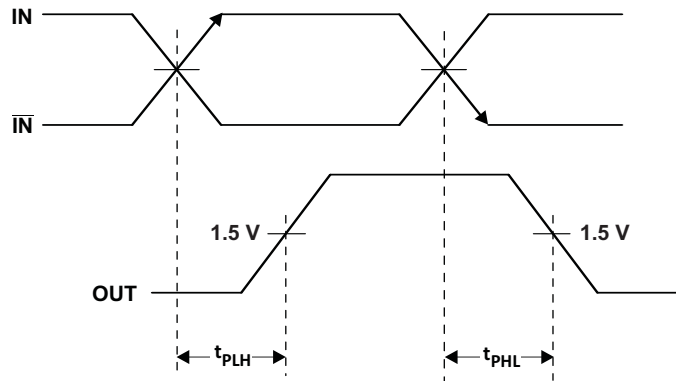

Figure 3. Output Propagation Delay

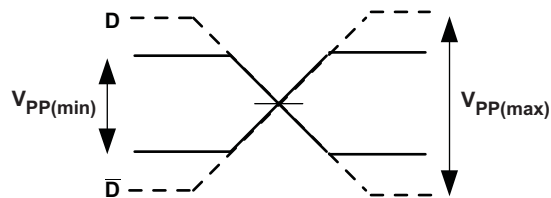
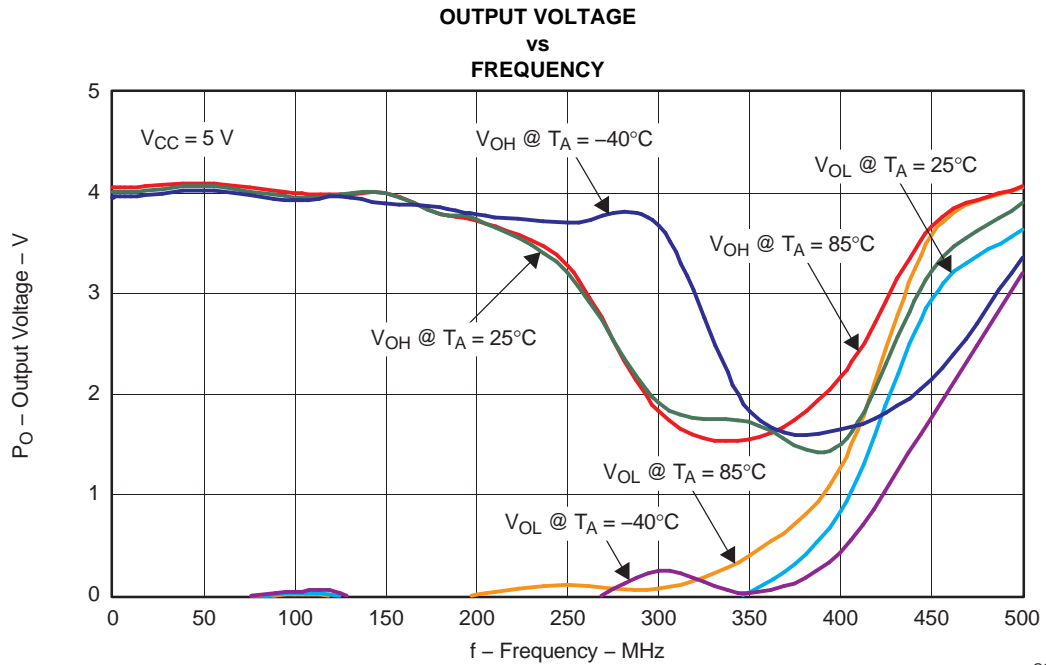

Figure 4. Input Voltage Swing



PACKAGING INFORMATION

Orderable Device	Status (1)	Package Type	Package Drawing	Pins	Package Qty	Eco Plan (2)	Lead finish/ Ball material (6)	MSL Peak Temp (3)	Op Temp (°C)	Device Marking (4/5)	Samples
SN65ELT23D	ACTIVE	SOIC	D	8	75	RoHS & Green	NIPDAU	Level-1-260C-UNLIM	-40 to 85	ELT23	Samples
SN65ELT23DGK	ACTIVE	VSSOP	DGK	8	80	RoHS & Green	NIPDAU	Level-1-260C-UNLIM	-40 to 85	SIKI	Samples
SN65ELT23DGKR	ACTIVE	VSSOP	DGK	8	2500	RoHS & Green	NIPDAU	Level-1-260C-UNLIM	-40 to 85	SIKI	Samples
SN65ELT23DR	ACTIVE	SOIC	D	8	2500	RoHS & Green	NIPDAU	Level-1-260C-UNLIM	-40 to 85	ELT23	Samples

(1) The marketing status values are defined as follows:

ACTIVE: Product device recommended for new designs.

LIFEBUY: TI has announced that the device will be discontinued, and a lifetime-buy period is in effect.

NRND: Not recommended for new designs. Device is in production to support existing customers, but TI does not recommend using this part in a new design.

PREVIEW: Device has been announced but is not in production. Samples may or may not be available.

OBSELETE: TI has discontinued the production of the device.

(2) **RoHS:** TI defines "RoHS" to mean semiconductor products that are compliant with the current EU RoHS requirements for all 10 RoHS substances, including the requirement that RoHS substance do not exceed 0.1% by weight in homogeneous materials. Where designed to be soldered at high temperatures, "RoHS" products are suitable for use in specified lead-free processes. TI may reference these types of products as "Pb-Free".

RoHS Exempt: TI defines "RoHS Exempt" to mean products that contain lead but are compliant with EU RoHS pursuant to a specific EU RoHS exemption.

Green: TI defines "Green" to mean the content of Chlorine (Cl) and Bromine (Br) based flame retardants meet JS709B low halogen requirements of <=1000ppm threshold. Antimony trioxide based flame retardants must also meet the <=1000ppm threshold requirement.

(3) **MSL, Peak Temp.** - The Moisture Sensitivity Level rating according to the JEDEC industry standard classifications, and peak solder temperature.

(4) There may be additional marking, which relates to the logo, the lot trace code information, or the environmental category on the device.

(5) Multiple Device Markings will be inside parentheses. Only one Device Marking contained in parentheses and separated by a "-" will appear on a device. If a line is indented then it is a continuation of the previous line and the two combined represent the entire Device Marking for that device.

(6) **Lead finish/Ball material** - Orderable Devices may have multiple material finish options. Finish options are separated by a vertical ruled line. Lead finish/Ball material values may wrap to two lines if the finish value exceeds the maximum column width.

Important Information and Disclaimer:The information provided on this page represents TI's knowledge and belief as of the date that it is provided. TI bases its knowledge and belief on information provided by third parties, and makes no representation or warranty as to the accuracy of such information. Efforts are underway to better integrate information from third parties. TI has taken and

continues to take reasonable steps to provide representative and accurate information but may not have conducted destructive testing or chemical analysis on incoming materials and chemicals. TI and TI suppliers consider certain information to be proprietary, and thus CAS numbers and other limited information may not be available for release.

In no event shall TI's liability arising out of such information exceed the total purchase price of the TI part(s) at issue in this document sold by TI to Customer on an annual basis.

TAPE AND REEL INFORMATION

QUADRANT ASSIGNMENTS FOR PIN 1 ORIENTATION IN TAPE



*All dimensions are nominal

Device	Package Type	Package Drawing	Pins	SPQ	Reel Diameter (mm)	Reel Width W1 (mm)	A0 (mm)	B0 (mm)	K0 (mm)	P1 (mm)	W (mm)	Pin1 Quadrant
SN65ELT23DGKR	VSSOP	DGK	8	2500	330.0	12.4	5.3	3.4	1.4	8.0	12.0	Q1
SN65ELT23DR	SOIC	D	8	2500	330.0	12.4	6.4	5.2	2.1	8.0	12.0	Q1

TAPE AND REEL BOX DIMENSIONS

*All dimensions are nominal

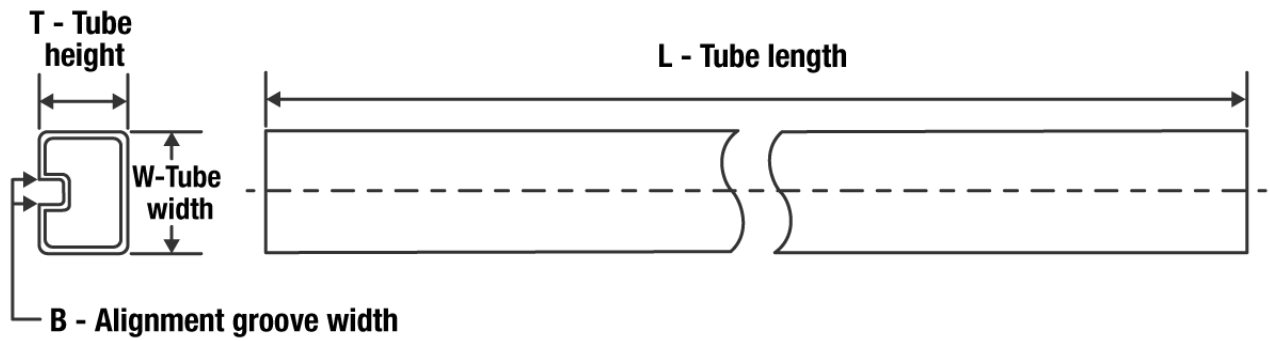
Device	Package Type	Package Drawing	Pins	SPQ	Length (mm)	Width (mm)	Height (mm)
SN65ELT23DGKR	VSSOP	DGK	8	2500	853.0	449.0	35.0
SN65ELT23DR	SOIC	D	8	2500	853.0	449.0	35.0

TUBE

*All dimensions are nominal

Device	Package Name	Package Type	Pins	SPQ	L (mm)	W (mm)	T (μm)	B (mm)
SN65ELT23D	D	SOIC	8	75	506.6	8	3940	4.32
SN65ELT23DGK	DGK	VSSOP	8	80	330.2	6.6	3005	1.88

DGK (S-PDSO-G8)

PLASTIC SMALL-OUTLINE PACKAGE

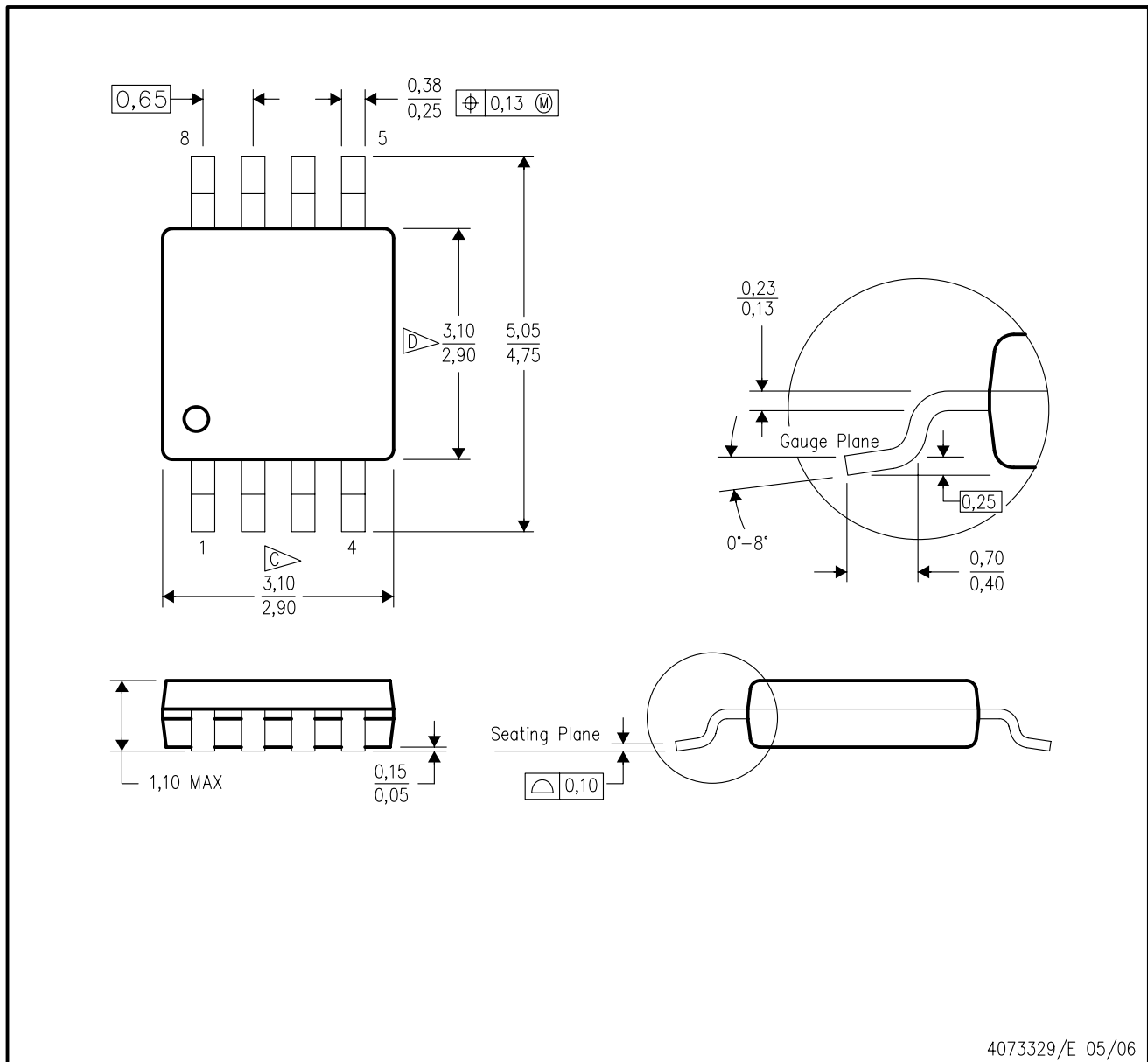

- NOTES:
- A. All linear dimensions are in millimeters.
 - B. This drawing is subject to change without notice.
 - C. Body length does not include mold flash, protrusions, or gate burrs. Mold flash, protrusions, or gate burrs shall not exceed 0.15 per end.
 - D. Body width does not include interlead flash. Interlead flash shall not exceed 0.50 per side.
 - E. Falls within JEDEC MO-187 variation AA, except interlead flash.

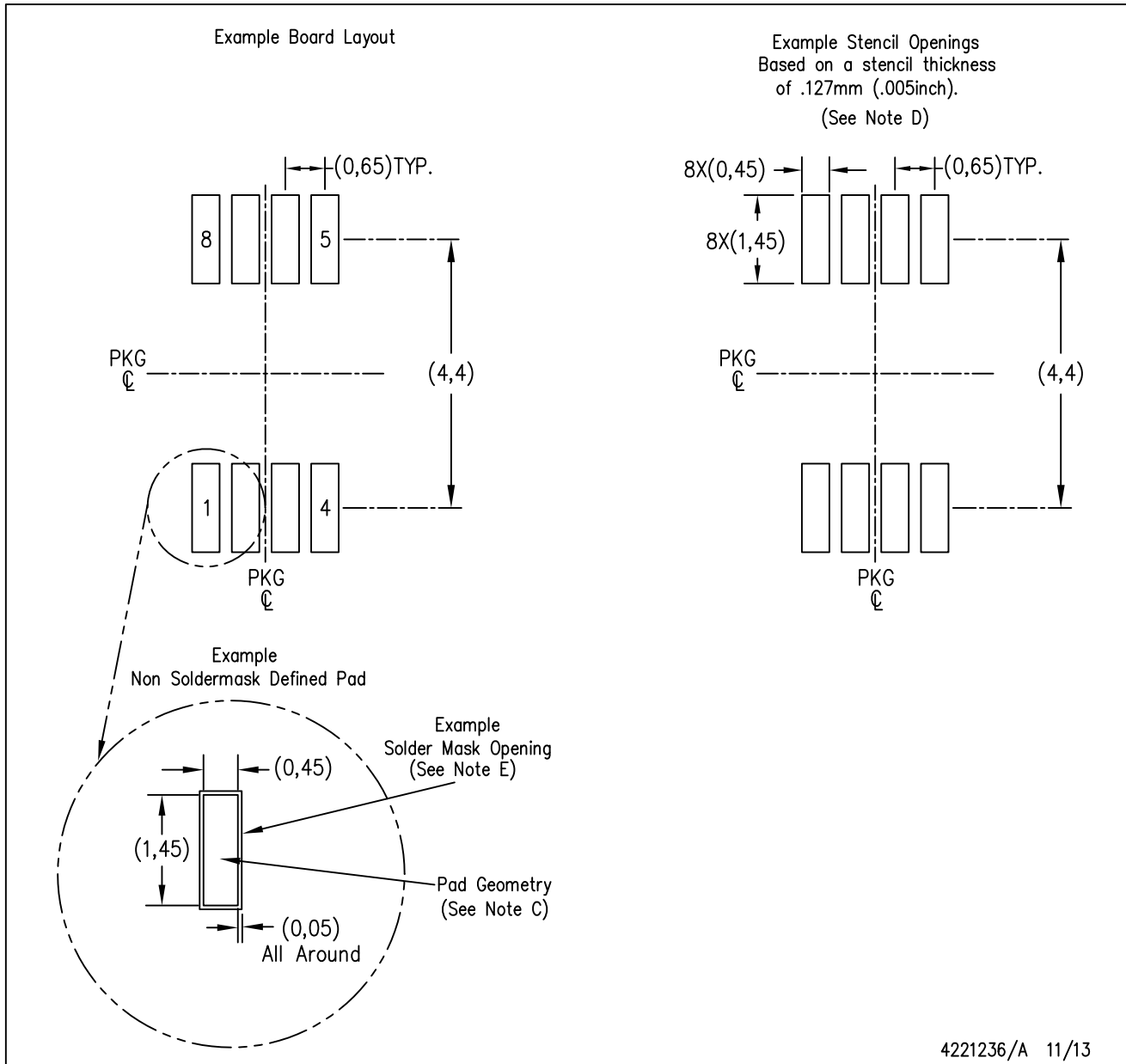

- NOTES:
- A. All linear dimensions are in millimeters.
 - B. This drawing is subject to change without notice.
 - C. Publication IPC-7351 is recommended for alternate designs.
 - D. Laser cutting apertures with trapezoidal walls and also rounding corners will offer better paste release. Customers should contact their board assembly site for stencil design recommendations. Refer to IPC-7525 for other stencil recommendations.
 - E. Customers should contact their board fabrication site for solder mask tolerances between and around signal pads.



D0008A

PACKAGE OUTLINE

SOIC - 1.75 mm max height

SMALL OUTLINE INTEGRATED CIRCUIT



4214825/C 02/2019

NOTES:

1. Linear dimensions are in inches [millimeters]. Dimensions in parenthesis are for reference only. Controlling dimensions are in inches. Dimensioning and tolerancing per ASME Y14.5M.
2. This drawing is subject to change without notice.
3. This dimension does not include mold flash, protrusions, or gate burrs. Mold flash, protrusions, or gate burrs shall not exceed $.006$ [0.15] per side.
4. This dimension does not include interlead flash.
5. Reference JEDEC registration MS-012, variation AA.

EXAMPLE BOARD LAYOUT

D0008A

SOIC - 1.75 mm max height

SMALL OUTLINE INTEGRATED CIRCUIT



LAND PATTERN EXAMPLE
 EXPOSED METAL SHOWN
 SCALE:8X



SOLDER MASK DETAILS

4214825/C 02/2019

NOTES: (continued)

- 6. Publication IPC-7351 may have alternate designs.
- 7. Solder mask tolerances between and around signal pads can vary based on board fabrication site.

EXAMPLE STENCIL DESIGN

D0008A

SOIC - 1.75 mm max height

SMALL OUTLINE INTEGRATED CIRCUIT



SOLDER PASTE EXAMPLE
BASED ON .005 INCH [0.125 MM] THICK STENCIL
SCALE:8X

4214825/C 02/2019

NOTES: (continued)

8. Laser cutting apertures with trapezoidal walls and rounded corners may offer better paste release. IPC-7525 may have alternate design recommendations.
9. Board assembly site may have different recommendations for stencil design.

IMPORTANT NOTICE AND DISCLAIMER

TI PROVIDES TECHNICAL AND RELIABILITY DATA (INCLUDING DATA SHEETS), DESIGN RESOURCES (INCLUDING REFERENCE DESIGNS), APPLICATION OR OTHER DESIGN ADVICE, WEB TOOLS, SAFETY INFORMATION, AND OTHER RESOURCES "AS IS" AND WITH ALL FAULTS, AND DISCLAIMS ALL WARRANTIES, EXPRESS AND IMPLIED, INCLUDING WITHOUT LIMITATION ANY IMPLIED WARRANTIES OF MERCHANTABILITY, FITNESS FOR A PARTICULAR PURPOSE OR NON-INFRINGEMENT OF THIRD PARTY INTELLECTUAL PROPERTY RIGHTS.

These resources are intended for skilled developers designing with TI products. You are solely responsible for (1) selecting the appropriate TI products for your application, (2) designing, validating and testing your application, and (3) ensuring your application meets applicable standards, and any other safety, security, regulatory or other requirements.

These resources are subject to change without notice. TI grants you permission to use these resources only for development of an application that uses the TI products described in the resource. Other reproduction and display of these resources is prohibited. No license is granted to any other TI intellectual property right or to any third party intellectual property right. TI disclaims responsibility for, and you will fully indemnify TI and its representatives against, any claims, damages, costs, losses, and liabilities arising out of your use of these resources.

TI's products are provided subject to [TI's Terms of Sale](#) or other applicable terms available either on ti.com or provided in conjunction with such TI products. TI's provision of these resources does not expand or otherwise alter TI's applicable warranties or warranty disclaimers for TI products.

TI objects to and rejects any additional or different terms you may have proposed.

Mailing Address: Texas Instruments, Post Office Box 655303, Dallas, Texas 75265
Copyright © 2022, Texas Instruments Incorporated