

- **Function and Pinout Compatible With the Fastest Bipolar Logic**
- **25-Ω Output Series Resistors Reduce Transmission-Line Reflection Noise**
- **Reduced  $V_{OH}$  (Typically = 3.3 V) Version of Equivalent FCT Functions**
- **Edge-Rate Control Circuitry for Significantly Improved Noise Characteristics**
- **$I_{off}$  Supports Partial-Power-Down Mode Operation**
- **Matched Rise and Fall Times**
- **3-State Outputs**
- **ESD Protection Exceeds JESD 22**
  - 2000-V Human-Body Model (A114-A)
  - 200-V Machine Model (A115-A)
  - 1000-V Charged-Device Model (C101)
- **Fully Compatible With TTL Input and Output Logic Levels**
- **12-mA Output Sink Current**  
**15-mA Output Source Current**

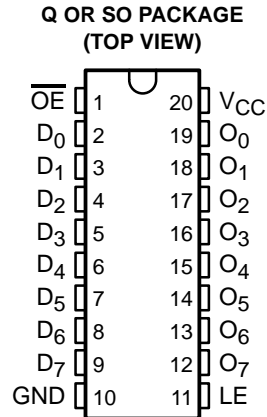

### description

The CY74FCT2573T is an 8-bit, high-speed CMOS, TTL-compatible buffered latch with 3-state outputs that is ideal for driving high-capacitance loads, such as memory and address buffers. On-chip 25-Ω termination resistors at the outputs reduce system noise caused by reflections. The CY74FCT2573T can replace the CY74FCT573T to reduce noise in an existing design.

When the latch-enable (LE) input is high, the flip-flops appear transparent to the data. Data that meets the required setup times are latched when LE transitions from high to low. Data appears on the bus when the output-enable ( $\overline{OE}$ ) input is low. When  $\overline{OE}$  is high, the bus output is in the high-impedance state. In this mode, data can be entered into the latches.

This device is fully specified for partial-power-down applications using  $I_{off}$ . The  $I_{off}$  circuitry disables the outputs, preventing damaging current backflow through the device when it is powered down.

### ORDERING INFORMATION

TA	PACKAGE†		SPEED (ns)	ORDERABLE PART NUMBER	TOP-SIDE MARKING
-40°C to 85°C	QSOP – Q	Tape and reel	4.7	CY74FCT2573CTQCT	FCT2573C
	SOIC – SO	Tube	4.7	CY74FCT2573CTSOC	FCT2573C
		Tape and reel	4.7	CY74FCT2573CTSOCT	
	QSOP – Q	Tape and reel	5.2	CY74FCT2573ATQCT	FCT2573A
	SOIC – SO	Tube	8	CY74FCT2573TSOC	FCT2573
		Tape and reel	8	CY74FCT2573TSOCT	

† Package drawings, standard packing quantities, thermal data, symbolization, and PCB design guidelines are available at [www.ti.com/sc/package](http://www.ti.com/sc/package).



Please be aware that an important notice concerning availability, standard warranty, and use in critical applications of Texas Instruments semiconductor products and disclaimers thereto appears at the end of this data sheet.

**CY74FCT2573T**  
**8-BIT LATCH**  
**WITH 3-STATE OUTPUTS**

SCCS075 – OCTOBER 2001

**FUNCTION TABLE**

INPUTS			OUTPUT
$\overline{OE}$	LE	D	O
L	H	H	H
L	H	L	L
L	L	X	$Q_0$
H	X	X	Z

H = High logic level, L = Low logic level,  
 X = Don't care, Z = High-impedance  
 state,  $Q_0$  = Previous state of flip flops  
 ( $Q_0-1$ )

**logic diagram**

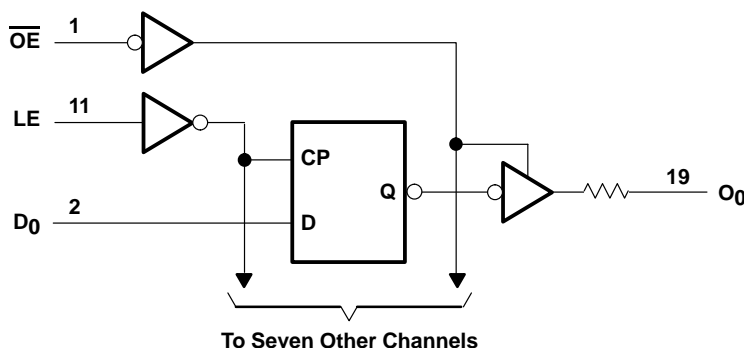

**absolute maximum ratings over operating free-air temperature range (unless otherwise noted)†**

Supply voltage range to ground potential	−0.5 V to 7 V
DC input voltage range	−0.5 V to 7 V
DC output voltage range	−0.5 V to 7 V
DC output current (maximum sink current/pin)	120 mA
Package thermal impedance, $\theta_{JA}$ (see Note 1): Q package	68°C/W
SO package	58°C/W
Ambient temperature range with power applied, $T_A$	−65°C to 135°C
Storage temperature range, $T_{stg}$	−65°C to 150°C

† Stresses beyond those listed under “absolute maximum ratings” may cause permanent damage to the device. These are stress ratings only, and functional operation of the device at these or any other conditions beyond those indicated under “recommended operating conditions” is not implied. Exposure to absolute-maximum-rated conditions for extended periods may affect device reliability.

NOTE 1: The package thermal impedance is calculated in accordance with JESD 51-7.

**recommended operating conditions (see Note 2)**

	MIN	NOM	MAX	UNIT
$V_{CC}$ Supply voltage	4.75	5	5.25	V
$V_{IH}$ High-level input voltage	2			V
$V_{IL}$ Low-level input voltage			0.8	V
$I_{OH}$ High-level output current			−15	mA
$I_{OL}$ Low-level output current			12	mA
$T_A$ Operating free-air temperature	−40		85	°C

NOTE 2: All unused inputs of the device must be held at  $V_{CC}$  or GND to ensure proper device operation.



POST OFFICE BOX 655303 • DALLAS, TEXAS 75265

**electrical characteristics over recommended operating free-air temperature range (unless otherwise noted)**

PARAMETER	TEST CONDITIONS		MIN	TYP†	MAX	UNIT
V <sub>IK</sub>	V <sub>CC</sub> = 4.75 V,	I <sub>IN</sub> = -18 mA		-0.7	-1.2	V
V <sub>OH</sub>	V <sub>CC</sub> = 4.75 V,	I <sub>OH</sub> = -15 mA	2.4	3.3		V
V <sub>OL</sub>	V <sub>CC</sub> = 4.75 V,	I <sub>OL</sub> = 12 mA		0.3	0.55	V
R <sub>OUT</sub>	V <sub>CC</sub> = 4.75 V,	I <sub>OL</sub> = 12 mA	20	28	40	Ω
V <sub>hys</sub>	All inputs			0.2		V
I <sub>I</sub>	V <sub>CC</sub> = 5.25 V,	V <sub>IN</sub> = V <sub>CC</sub>			5	μA
I <sub>IH</sub>	V <sub>CC</sub> = 5.25 V,	V <sub>IN</sub> = 2.7 V			±1	μA
I <sub>IL</sub>	V <sub>CC</sub> = 5.25 V,	V <sub>IN</sub> = 0.5 V			±1	μA
I <sub>OZH</sub>	V <sub>CC</sub> = 5.25 V,	V <sub>OUT</sub> = 2.7 V			10	μA
I <sub>OZL</sub>	V <sub>CC</sub> = 5.25 V,	V <sub>OUT</sub> = 0.5 V			-10	μA
I <sub>OS</sub> ‡	V <sub>CC</sub> = 5.25 V,	V <sub>OUT</sub> = 0 V	-60	-120	-225	mA
I <sub>off</sub>	V <sub>CC</sub> = 0 V,	V <sub>OUT</sub> = 4.5 V			±1	μA
I <sub>CC</sub>	V <sub>CC</sub> = 5.25 V,	V <sub>IN</sub> ≤ 0.2 V, V <sub>IN</sub> ≥ V <sub>CC</sub> - 0.2 V		0.1	0.2	mA
ΔI <sub>CC</sub>	V <sub>CC</sub> = 5.25 V, V <sub>IN</sub> = 3.4 V <sup>§</sup> , f <sub>1</sub> = 0, Outputs open			0.5	2	mA
I <sub>CCD</sub> ¶	V <sub>CC</sub> = 5.25 V, One input switching at 50% duty cycle, Outputs open, OE = GND, V <sub>IN</sub> ≤ 0.2 V or V <sub>IN</sub> ≥ V <sub>CC</sub> - 0.2 V			0.06	0.12	mA/MHz
I <sub>C</sub> #	V <sub>CC</sub> = 5.25 V, Outputs open, OE = GND, LE = V <sub>CC</sub>	One input switching at f <sub>1</sub> = 10 MHz at 50% duty cycle	V <sub>IN</sub> ≤ 0.2 V or V <sub>IN</sub> ≥ V <sub>CC</sub> - 0.2 V	0.7	1.4	mA
			V <sub>IN</sub> = 3.4 V or GND	1	2.4	
		Eight bits switching at f <sub>1</sub> = 2.5 MHz at 50% duty cycle	V <sub>IN</sub> ≤ 0.2 V or V <sub>IN</sub> ≥ V <sub>CC</sub> - 0.2 V	1.3	2.6	
			V <sub>IN</sub> = 3.4 V or GND	3.3	10.6	
C <sub>i</sub>				6	10	pF
C <sub>o</sub>				8	12	pF

† Typical values are at V<sub>CC</sub> = 5 V, T<sub>A</sub> = 25°C.

‡ Not more than one output should be shorted at a time. Duration of short should not exceed one second. The use of high-speed test apparatus and/or sample-and-hold techniques are preferable to minimize internal chip heating and more accurately reflect operational values. Otherwise, prolonged shorting of a high output can raise the chip temperature well above normal and cause invalid readings in other parametric tests. In any sequence of parameter tests, I<sub>OS</sub> tests should be performed last.

§ Per TTL-driven input (V<sub>IN</sub> = 3.4 V); all other inputs at V<sub>CC</sub> or GND

¶ This parameter is derived for use in total power-supply calculations.

# I<sub>C</sub> = I<sub>CC</sub> + ΔI<sub>CC</sub> × D<sub>H</sub> × N<sub>T</sub> + I<sub>CCD</sub>(f<sub>0</sub>/2 + f<sub>1</sub> × N<sub>1</sub>)

Where:

I<sub>C</sub> = Total supply current

I<sub>CC</sub> = Power-supply current with CMOS input levels

ΔI<sub>CC</sub> = Power-supply current for a TTL high input (V<sub>IN</sub> = 3.4 V)

D<sub>H</sub> = Duty cycle for TTL inputs high

N<sub>T</sub> = Number of TTL inputs at D<sub>H</sub>

I<sub>CCD</sub> = Dynamic current caused by an input transition pair (HLH or LHL)

f<sub>0</sub> = Clock frequency for registered devices, otherwise zero

f<sub>1</sub> = Input signal frequency

N<sub>1</sub> = Number of inputs changing at f<sub>1</sub>

All currents are in milliamperes and all frequencies are in megahertz.

|| Values for these conditions are examples of the I<sub>CC</sub> formula.

**CY74FCT2573T**  
**8-BIT LATCH**  
**WITH 3-STATE OUTPUTS**

SCCS075 – OCTOBER 2001

timing requirements over recommended operating free-air temperature range (unless otherwise noted) (see Figure 1)

		CY74FCT2573T		CY74FCT2573AT		CY74FCT2573CT		UNIT
		MIN	MAX	MIN	MAX	MIN	MAX	
$t_w$	Pulse duration, LE high	6		5		5		ns
$t_{su}$	Setup time, D to LE	2		2		2		ns
$t_h$	Hold time, D to LE	1.5		1.5		1.5		ns

switching characteristics over operating free-air temperature range (see Figure 1)

PARAMETER	FROM (INPUT)	TO (OUTPUT)	CY74FCT2573T		CY74FCT2573AT		CY74FCT2573CT		UNIT
			MIN	MAX	MIN	MAX	MIN	MAX	
$t_{PLH}$	D	O	1.5	8	1.5	5.2	1.5	4.7	ns
$t_{PHL}$			1.5	8	1.5	5.2	1.5	4.7	
$t_{PLH}$	LE	O	2	13	2	8.5	2	5.5	ns
$t_{PHL}$			2	13	2	8.5	2	5.5	
$t_{PZH}$	$\overline{OE}$	O	1.5	11	1.5	6.5	1.5	5.5	ns
$t_{PZL}$			1.5	11	1.5	6.5	1.5	5.5	
$t_{PHZ}$	$\overline{OE}$	O	1.5	7	1.5	5.5	1.5	5	ns
$t_{PLZ}$			1.5	7	1.5	5.5	1.5	5	



PARAMETER MEASUREMENT INFORMATION

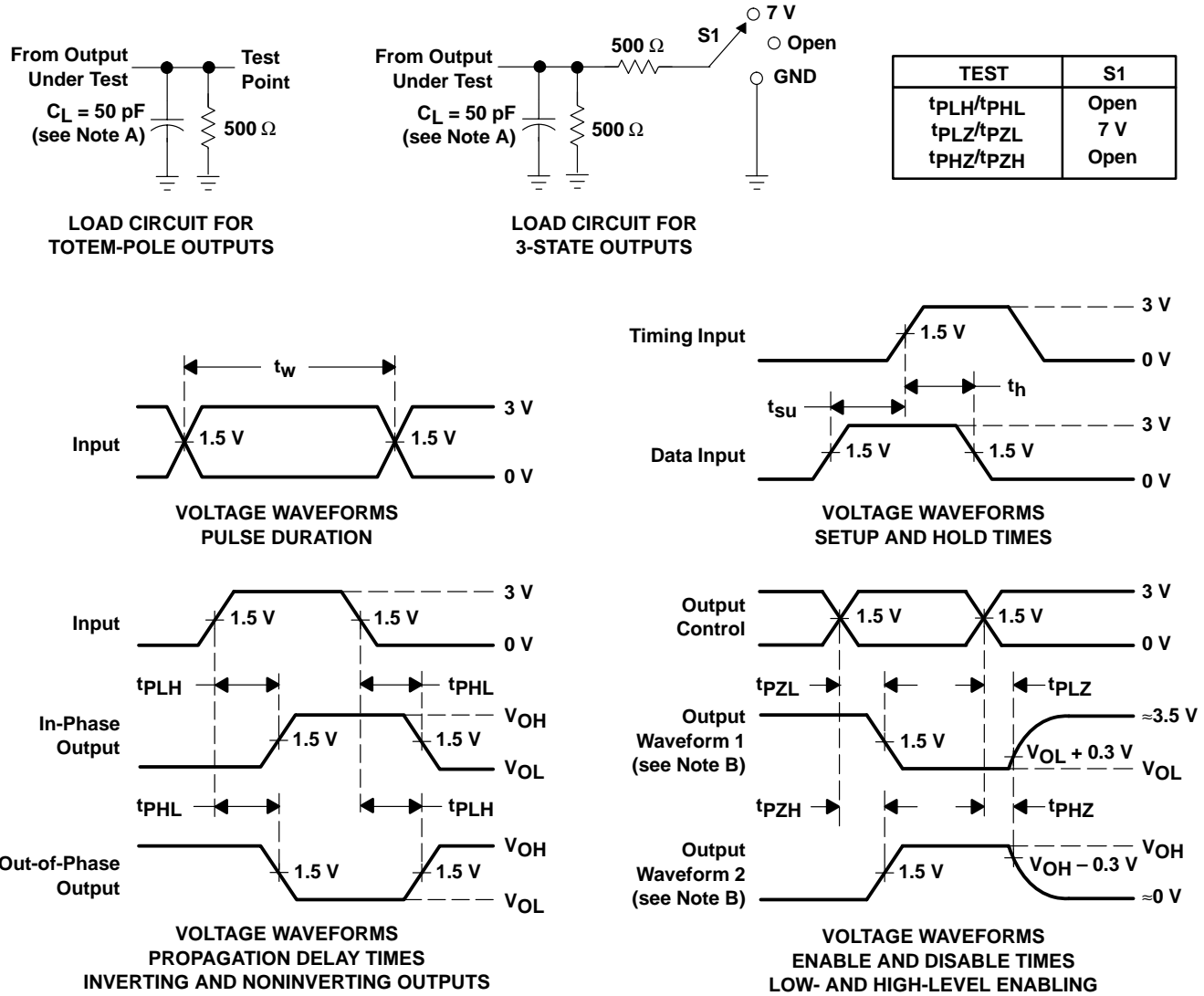

- NOTES: A.  $C_L$  includes probe and jig capacitance.  
 B. Waveform 1 is for an output with internal conditions such that the output is low except when disabled by the output control. Waveform 2 is for an output with internal conditions such that the output is high except when disabled by the output control.  
 C. The outputs are measured one at a time with one input transition per measurement.

Figure 1. Load Circuit and Voltage Waveforms

**PACKAGING INFORMATION**

Orderable Device	Status (1)	Package Type	Package Drawing	Pins	Package Qty	Eco Plan (2)	Lead finish/ Ball material (6)	MSL Peak Temp (3)	Op Temp (°C)	Device Marking (4/5)	Samples
CY74FCT2573ATQCT	ACTIVE	SSOP	DBQ	20	2500	RoHS & Green	NIPDAU	Level-2-260C-1 YEAR	-40 to 85	FCT2573A	<a href="#">Samples</a>
CY74FCT2573CTQCT	ACTIVE	SSOP	DBQ	20	2500	RoHS & Green	NIPDAU	Level-2-260C-1 YEAR	-40 to 85	FCT2573C	<a href="#">Samples</a>
CY74FCT2573CTSOC	ACTIVE	SOIC	DW	20	25	RoHS & Green	NIPDAU	Level-1-260C-UNLIM	-40 to 85	FCT2573C	<a href="#">Samples</a>
CY74FCT2573CTSOCG4	ACTIVE	SOIC	DW	20	25	RoHS & Green	NIPDAU	Level-1-260C-UNLIM	-40 to 85	FCT2573C	<a href="#">Samples</a>
CY74FCT2573CTSOCT	ACTIVE	SOIC	DW	20	2000	RoHS & Green	NIPDAU	Level-1-260C-UNLIM	-40 to 85	FCT2573C	<a href="#">Samples</a>
CY74FCT2573TSOC	ACTIVE	SOIC	DW	20	25	RoHS & Green	NIPDAU	Level-1-260C-UNLIM	-40 to 85	FCT2573	<a href="#">Samples</a>
CY74FCT2573TSOCT	ACTIVE	SOIC	DW	20	2000	RoHS & Green	NIPDAU	Level-1-260C-UNLIM	-40 to 85	FCT2573	<a href="#">Samples</a>

(1) The marketing status values are defined as follows:

**ACTIVE:** Product device recommended for new designs.

**LIFEBUY:** TI has announced that the device will be discontinued, and a lifetime-buy period is in effect.

**NRND:** Not recommended for new designs. Device is in production to support existing customers, but TI does not recommend using this part in a new design.

**PREVIEW:** Device has been announced but is not in production. Samples may or may not be available.

**OBSOLETE:** TI has discontinued the production of the device.

(2) **RoHS:** TI defines "RoHS" to mean semiconductor products that are compliant with the current EU RoHS requirements for all 10 RoHS substances, including the requirement that RoHS substance do not exceed 0.1% by weight in homogeneous materials. Where designed to be soldered at high temperatures, "RoHS" products are suitable for use in specified lead-free processes. TI may reference these types of products as "Pb-Free".

**RoHS Exempt:** TI defines "RoHS Exempt" to mean products that contain lead but are compliant with EU RoHS pursuant to a specific EU RoHS exemption.

**Green:** TI defines "Green" to mean the content of Chlorine (Cl) and Bromine (Br) based flame retardants meet JS709B low halogen requirements of <=1000ppm threshold. Antimony trioxide based flame retardants must also meet the <=1000ppm threshold requirement.

(3) MSL, Peak Temp. - The Moisture Sensitivity Level rating according to the JEDEC industry standard classifications, and peak solder temperature.

(4) There may be additional marking, which relates to the logo, the lot trace code information, or the environmental category on the device.

(5) Multiple Device Markings will be inside parentheses. Only one Device Marking contained in parentheses and separated by a "~" will appear on a device. If a line is indented then it is a continuation of the previous line and the two combined represent the entire Device Marking for that device.

<sup>(6)</sup> Lead finish/Ball material - Orderable Devices may have multiple material finish options. Finish options are separated by a vertical ruled line. Lead finish/Ball material values may wrap to two lines if the finish value exceeds the maximum column width.

**Important Information and Disclaimer:**The information provided on this page represents TI's knowledge and belief as of the date that it is provided. TI bases its knowledge and belief on information provided by third parties, and makes no representation or warranty as to the accuracy of such information. Efforts are underway to better integrate information from third parties. TI has taken and continues to take reasonable steps to provide representative and accurate information but may not have conducted destructive testing or chemical analysis on incoming materials and chemicals. TI and TI suppliers consider certain information to be proprietary, and thus CAS numbers and other limited information may not be available for release.

In no event shall TI's liability arising out of such information exceed the total purchase price of the TI part(s) at issue in this document sold by TI to Customer on an annual basis.

**TAPE AND REEL INFORMATION**

**QUADRANT ASSIGNMENTS FOR PIN 1 ORIENTATION IN TAPE**

\*All dimensions are nominal

Device	Package Type	Package Drawing	Pins	SPQ	Reel Diameter (mm)	Reel Width W1 (mm)	A0 (mm)	B0 (mm)	K0 (mm)	P1 (mm)	W (mm)	Pin1 Quadrant
CY74FCT2573ATQCT	SSOP	DBQ	20	2500	330.0	16.4	6.5	9.0	2.1	8.0	16.0	Q1
CY74FCT2573CTQCT	SSOP	DBQ	20	2500	330.0	16.4	6.5	9.0	2.1	8.0	16.0	Q1
CY74FCT2573CTSOCT	SOIC	DW	20	2000	330.0	24.4	10.8	13.3	2.7	12.0	24.0	Q1
CY74FCT2573TSOCT	SOIC	DW	20	2000	330.0	24.4	10.8	13.3	2.7	12.0	24.0	Q1

**TAPE AND REEL BOX DIMENSIONS**

\*All dimensions are nominal

Device	Package Type	Package Drawing	Pins	SPQ	Length (mm)	Width (mm)	Height (mm)
CY74FCT2573ATQCT	SSOP	DBQ	20	2500	853.0	449.0	35.0
CY74FCT2573CTQCT	SSOP	DBQ	20	2500	853.0	449.0	35.0
CY74FCT2573CTSOCT	SOIC	DW	20	2000	367.0	367.0	45.0
CY74FCT2573TSOCT	SOIC	DW	20	2000	367.0	367.0	45.0

**TUBE**

\*All dimensions are nominal

Device	Package Name	Package Type	Pins	SPQ	L (mm)	W (mm)	T (μm)	B (mm)
CY74FCT2573CTSOC	DW	SOIC	20	25	507	12.83	5080	6.6
CY74FCT2573CTSOCG4	DW	SOIC	20	25	507	12.83	5080	6.6
CY74FCT2573TSOC	DW	SOIC	20	25	507	12.83	5080	6.6

DBQ (R-PDSO-G20)

PLASTIC SMALL-OUTLINE PACKAGE

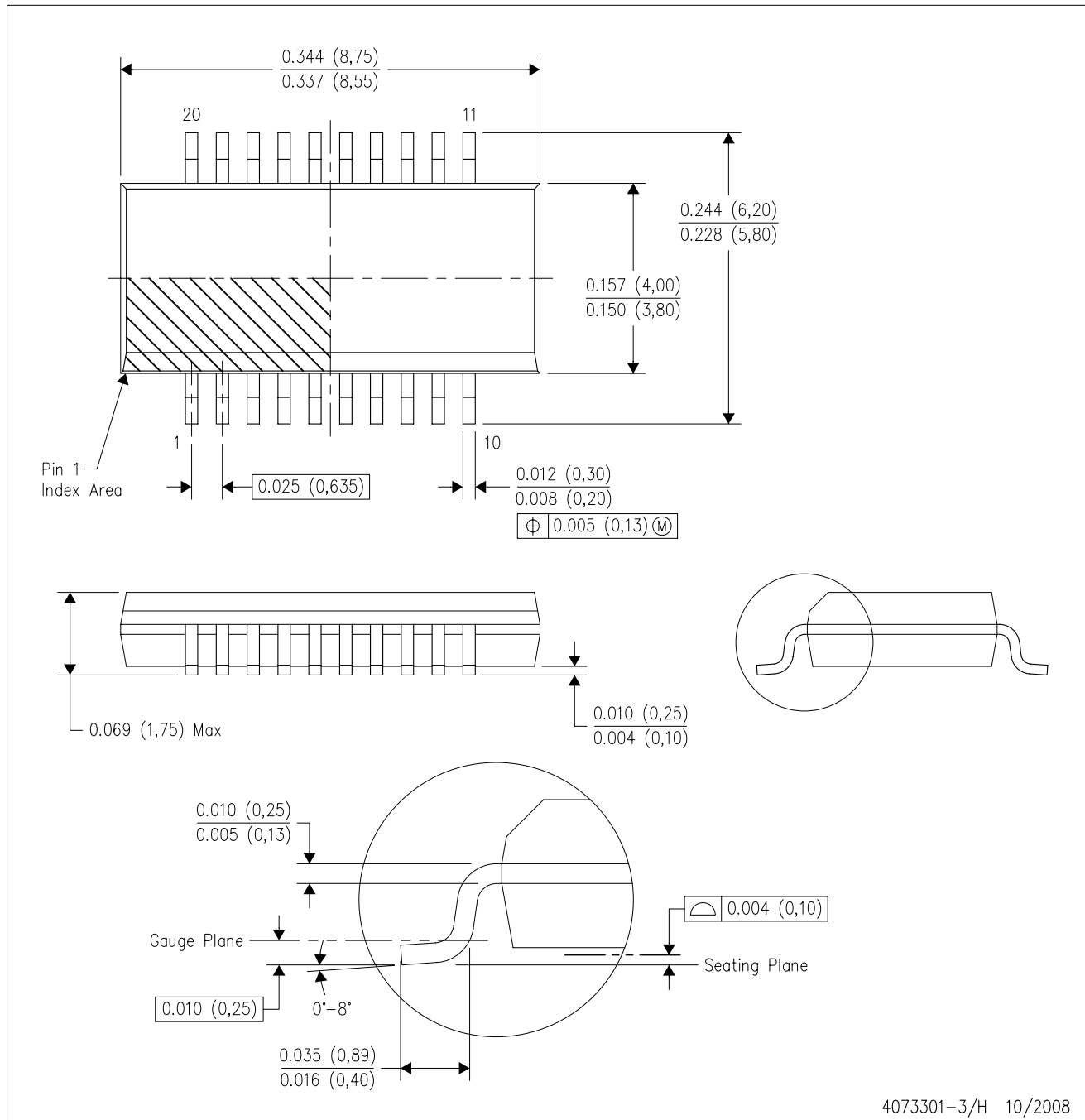

- NOTES:
- A. All linear dimensions are in inches (millimeters).
  - B. This drawing is subject to change without notice.
  - C. Body dimensions do not include mold flash or protrusion not to exceed 0.006 (0,15) per side.
  - D. Falls within JEDEC MO-137 variation AD.

# DW0020A



# PACKAGE OUTLINE

## SOIC - 2.65 mm max height

SOIC

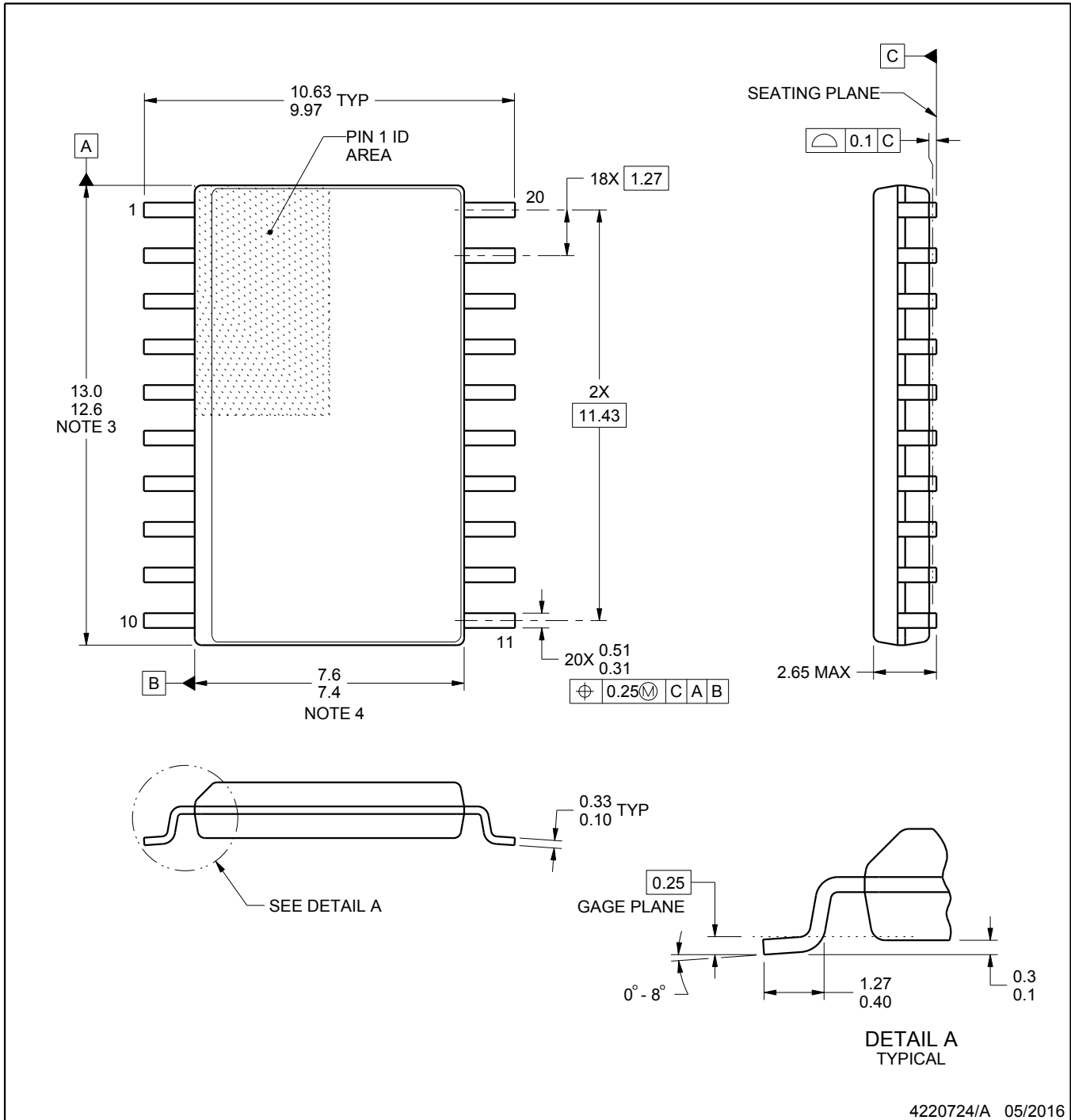

4220724/A 05/2016

# EXAMPLE BOARD LAYOUT

DW0020A

SOIC - 2.65 mm max height

SOIC



LAND PATTERN EXAMPLE  
SCALE:6X



SOLDER MASK DETAILS

4220724/A 05/2016

NOTES: (continued)

- 6. Publication IPC-7351 may have alternate designs.
- 7. Solder mask tolerances between and around signal pads can vary based on board fabrication site.

# EXAMPLE STENCIL DESIGN

DW0020A

SOIC - 2.65 mm max height

SOIC

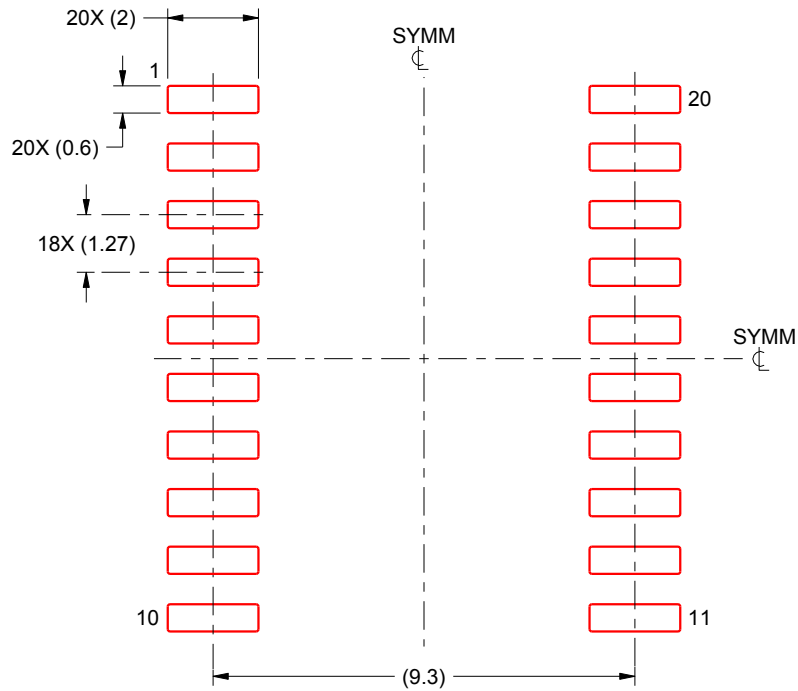

SOLDER PASTE EXAMPLE  
BASED ON 0.125 mm THICK STENCIL  
SCALE:6X

4220724/A 05/2016

NOTES: (continued)

8. Laser cutting apertures with trapezoidal walls and rounded corners may offer better paste release. IPC-7525 may have alternate design recommendations.
9. Board assembly site may have different recommendations for stencil design.

## IMPORTANT NOTICE AND DISCLAIMER

TI PROVIDES TECHNICAL AND RELIABILITY DATA (INCLUDING DATA SHEETS), DESIGN RESOURCES (INCLUDING REFERENCE DESIGNS), APPLICATION OR OTHER DESIGN ADVICE, WEB TOOLS, SAFETY INFORMATION, AND OTHER RESOURCES "AS IS" AND WITH ALL FAULTS, AND DISCLAIMS ALL WARRANTIES, EXPRESS AND IMPLIED, INCLUDING WITHOUT LIMITATION ANY IMPLIED WARRANTIES OF MERCHANTABILITY, FITNESS FOR A PARTICULAR PURPOSE OR NON-INFRINGEMENT OF THIRD PARTY INTELLECTUAL PROPERTY RIGHTS.

These resources are intended for skilled developers designing with TI products. You are solely responsible for (1) selecting the appropriate TI products for your application, (2) designing, validating and testing your application, and (3) ensuring your application meets applicable standards, and any other safety, security, regulatory or other requirements.

These resources are subject to change without notice. TI grants you permission to use these resources only for development of an application that uses the TI products described in the resource. Other reproduction and display of these resources is prohibited. No license is granted to any other TI intellectual property right or to any third party intellectual property right. TI disclaims responsibility for, and you will fully indemnify TI and its representatives against, any claims, damages, costs, losses, and liabilities arising out of your use of these resources.

TI's products are provided subject to [TI's Terms of Sale](#) or other applicable terms available either on [ti.com](http://ti.com) or provided in conjunction with such TI products. TI's provision of these resources does not expand or otherwise alter TI's applicable warranties or warranty disclaimers for TI products.

TI objects to and rejects any additional or different terms you may have proposed.

Mailing Address: Texas Instruments, Post Office Box 655303, Dallas, Texas 75265  
Copyright © 2022, Texas Instruments Incorporated