

TPS7B68-Q1 500mA 40V 高电压超低静态电流看门狗 LDO

1 特性

- 适用于汽车电子 应用
- 具有符合 AEC-Q100 标准的下列结果：
 - 器件温度 1 级：-40°C 至 +125°C 的环境工作温度范围
 - 器件 HBM ESD 分类等级 2
 - 器件 CDM ESD 分类等级 C4B
- 最大输出电流：500mA
- 4V 至 40V 宽 V_{IN} 输入电压范围，瞬态电压高达 45V
- 3.3V 和 5V 两种固定输出电压
- 最大压降电压：600mV（电流为 500mA）
- 在宽电容（4.7 μ F 至 500 μ F）和 ESR（0.001 Ω 至 20 Ω ）范围内，与输出电容器一起工作时保持稳定
- 低静态电流 ($I_{(Q)}$):
 - EN 为低电平（关断模式）时 < 4 μ A
 - 轻负载（ $\overline{WD_EN}$ 为高电平）时具有 19 μ A 的典型值（看门狗禁用）
- 可针对窗口看门狗和标准看门狗进行配置
- 开关窗口比例可配置为 1:1 或 8:1
- 完全可调的看门狗周期（10ms 至 500ms）
- 10% 精度看门狗周期
- 专用 $\overline{WD_EN}$ 引脚，用于控制看门狗开关
- 完全可调的电源正常阈值和电源正常延迟周期
- 针对 UVLO 的低输入电压跟踪功能
- 集成故障保护：
 - 过载电流限制保护
 - 热关断
- 28 引脚 HTSSOP 封装

2 应用

- 汽车 MCU 电源
- 车身控制模块 (BCM)
- 车身舒适模块
- EV 和 HEV 电池管理系统(BMS)
- 电子换挡器
- 变速器控制单元 (TCU)
- 电动助力转向 (EPS)

3 说明

在汽车微控制器或微处理器电源 应用中，看门狗用于监测微控制器的工作状态，防止软件失控。在可靠的系统中，看门狗必须独立于微控制器。

TPS7B68-Q1 是一款专为实现高达 40V 的工作电压而设计的 500mA 看门狗 LDO，其轻载条件下的典型静态电流仅为 19 μ A。该器件集成了一项可编程功能，用于选择窗口或标准看门狗，并使用外部电阻器来设置看门狗时间（精度在 10% 以内）。

TPS7B68-Q1 上的 PG 引脚指示输出电压何时达到稳定且处于稳压范围内。电源正常延迟周期和电源正常阈值可通过外部组件来调整。此外，该器件还具备短路和过流保护。这些特性 组合 使得该器件极具灵活性，适用于为汽车应用中的微控制器 供电。

器件信息(1)

器件型号	封装	封装尺寸（标称值）
TPS7B68-Q1	HTSSOP (28)	9.70mm x 4.40mm

(1) 要了解所有可用封装，请见数据表末尾的可订购产品附录。

典型应用原理图

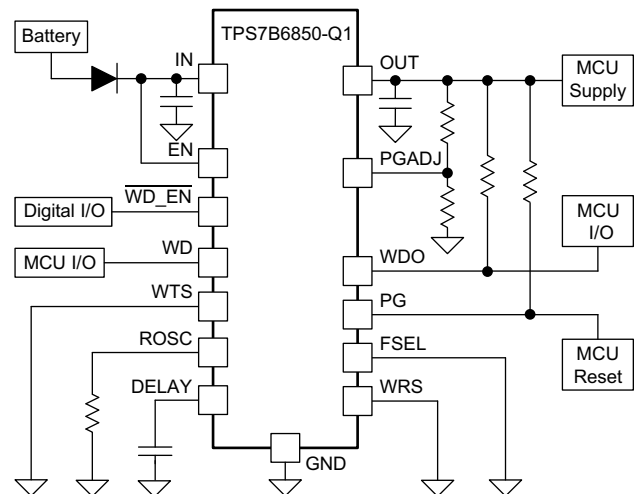

目录

1	特性	1	7.4	Device Functional Modes.....	21
2	应用	1	8	Application and Implementation	22
3	说明	1	8.1	Application Information.....	22
4	修订历史记录	2	8.2	Typical Application	22
5	Pin Configuration and Functions	4	9	Power Supply Recommendations	25
6	Specifications.....	5	10	Layout.....	25
6.1	Absolute Maximum Ratings	5	10.1	Layout Guidelines	25
6.2	ESD Ratings.....	6	10.2	Layout Example	25
6.3	Recommended Operating Conditions.....	6	11	器件和文档支持	26
6.4	Thermal Information	6	11.1	文档支持	26
6.5	Electrical Characteristics.....	7	11.2	接收文档更新通知	26
6.6	Switching Characteristics	9	11.3	社区资源.....	26
6.7	Typical Characteristics	10	11.4	商标.....	26
7	Detailed Description	14	11.5	静电放电警告.....	26
7.1	Overview	14	11.6	术语表	26
7.2	Functional Block Diagram	14	12	机械、封装和可订购信息.....	26
7.3	Feature Description.....	14			

4 修订历史记录

注：之前版本的页码可能与当前版本有所不同。

Changes from Revision B (September 2017) to Revision C	Page
• 已更改 通篇将看门狗精度从 9% 更改成了 10%.....	1
• 已更改 更改了器件信息表	1
• Changed test conditions of V_{OUT} parameter	7
• Added second row to V_{OUT} parameter	7
• Changed $V_{(dropout)}$ parameter maximum specifications from 600 mV to 800 mV at 500 mA and changed 260 mV to 325 mV at 200 mA.....	7
• Added footnote indicating dropout is not tested for the 3.3-V option at 200 mA.....	7
• Changed first row test conditions of $I_{(LIM)}$ parameter: changed $V_{IN} = 5.6 V$ to $40 V$ to $V_{IN} = 5.6 V$ and added voltage option	7
• Added second row to $I_{(LIM)}$ parameter for the 3.3-V option.....	7
• Changed $t_{(DEGLITCH)}$ parameter minimum specification from 100 μs to 55 μs	9
• Changed $t_{(DLY_FIX)}$ parameter specifications: deleted minimum specification and changed maximum specification from 550 μs to 900 μs	9
• Changed $t_{(WD_TOL)}$ parameter: changes test conditions, changed minim specification from -9% to -10%, and changed maximum specification from 9% to 10%.....	9
• 已更改 <i>Several Typical Periods of Watchdog Window</i> table to reflect change in watchdog duration accuracy from 9% to 10%	17

Changes from Revision A (December 2016) to Revision B	Page
• Changed $V_{(PG_TH)}$ symbol to $V_{(PG_TH)}$ rising and $V_{(PGADJ_TH)}$ symbol to $V_{(PGADJ_TH)}$ falling in <i>Electrical Characteristics</i> table	8
• Added $V_{(PGADJ_HYST)}$ parameter to <i>Electrical Characteristics</i> table	8
• 已更改 <i>Adjustable Power-Good Threshold</i> section: updated symbols and changed Equation 1	15
• 已更改 parameter symbols in <i>Power Up and Conditions for Activation of Power Good</i> figure and added footnote.....	16
• 已更改 parameter symbols in <i>Window Watchdog Operation</i> figure and added footnote	20
• 已更改 parameter symbols in <i>Standard Watchdog Operation</i> figure and added footnote	21

Changes from Original (June 2016) to Revision A**Page**

-
- 已将 TPS7B6850-Q1 的状态从产品预览改为量产数据..... 1
-

5 Pin Configuration and Functions

PWP PowerPAD™ Package
28-Pin HTSSOP With Exposed Thermal Pad
Top View

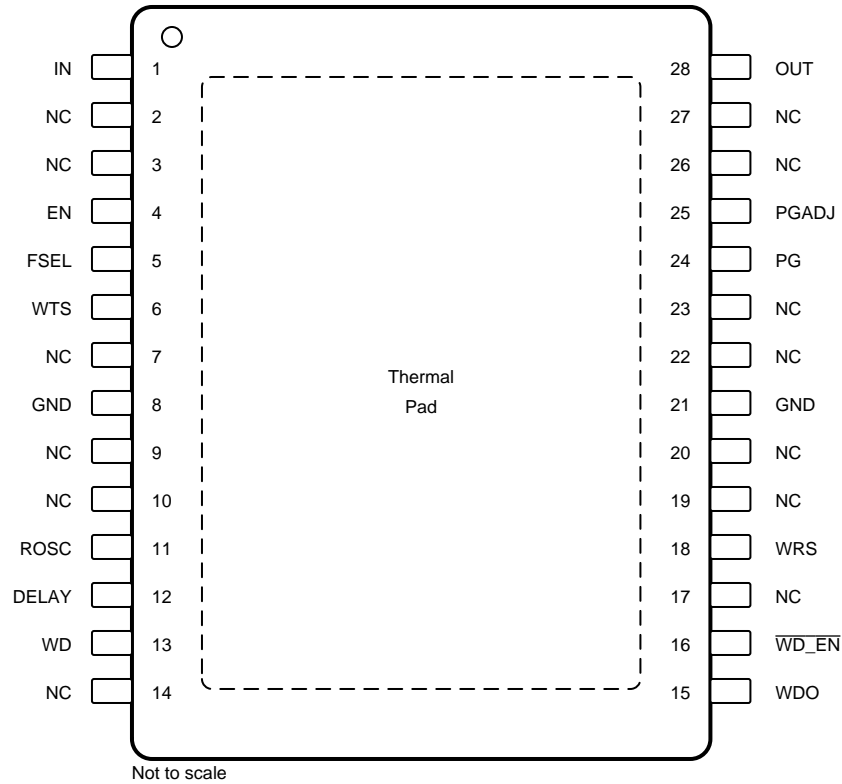

NC - No internal connection

Pin Functions

PIN		TYPE ⁽¹⁾	DESCRIPTION
NAME	NO.		
DELAY	12	O	Power-good delay-period adjustment pin. Connect this pin via a capacitor to ground to adjust the power-good delay time.
EN	4	I	Device enable pin. Pull this pin down to low-level voltage to disable the device. Pull this pin up to high-level voltage to enable the device.
FSEL	5	I	Internal oscillator-frequency selection pin. Pull this pin down to low-level voltage to select the high-frequency oscillator. Pull this pin up to high-level voltage to select the low-frequency oscillator.
GND	8, 21	G	Ground reference
IN	1	I	Device input power-supply pin
NC	2, 3, 7, 9, 10, 14, 17, 19, 20, 22, 23, 26, 27	—	Not connected
OUT	28	O	Device 3.3-V or 5-V regulated output voltage pin
PG	24	O	Power-good pin. Open-drain output pin. Pull this pin up to V_{OUT} or to a reference through a resistor. When the output voltage is not ready, this pin is pulled down to ground.
PGADJ	25	O	Power-good threshold-adjustment pin. Connect a resistor divider between the PGADJ and OUT pins to set the power-good threshold. Connect this pin to ground to set the threshold to 91.6% of output voltage V_{OUT} .

(1) I = input, O = output, G = ground.

Pin Functions (continued)

PIN		TYPE ⁽¹⁾	DESCRIPTION
NAME	NO.		
ROSC	11	O	Watchdog timer adjustment pin. Connect a resistor between the ROSC pin and the GND pin to set the duration of the watchdog monitor. Leaving this pin open or connecting this pin to ground results in the watchdog reporting a fault at the watchdog output (WDO).
WD	13	I	Watchdog service-signal input pin.
WDO	15	O	Watchdog status pin. Open-drain output pin. Pull this pin up to OUT or a reference voltage through a resistor. When watchdog fault occurs, this pin is pulled down to a low-level voltage.
$\overline{\text{WD_EN}}$	16	I	Watchdog enable pin. Pull this pin down to a low level to enable the watchdog. Pull this pin up to a high level to disable the watchdog.
WRS	18	I	Window ratio selection pin (only applicable for the window watchdog). Pull this pin down to a low level to set the open:closed window ratio to 1:1. Pull this pin up to high level to set the open:closed window ratio to 8:1.
WTS	6	O	Watchdog type-selection pin. To set the window watchdog, connect this pin to the GND pin. To set the standard watchdog, pull this pin high.

6 Specifications

6.1 Absolute Maximum Ratings

over operating ambient temperature range (unless otherwise noted)⁽¹⁾⁽²⁾

		MIN	MAX	UNIT
Unregulated input	IN, EN	-0.3	45	V
Internal oscillator reference voltage	ROSC	-0.3	7	V
Power-good delay-timer output	DELAY	-0.3	7	V
Regulated output	OUT	-0.3	7	V
Power-good output voltage	PG	-0.3	7	V
Watchdog status output voltage	WDO	-0.3	7	V
Watchdog frequency selection, watchdog-type selection	FSEL, WTS	-0.3	45	V
Watchdog enable	$\overline{\text{WD_EN}}$	-0.3	7	V
Watchdog service signal voltage	WD	-0.3	7	V
Window ratio selection	WRS	-0.3	7	V
Power good threshold adjustment voltage	PGADJ	-0.3	7	V
Operating junction temperature, T _J		-40	150	°C
Storage temperature, T _{stg}		-65	150	°C

- (1) Stresses beyond those listed under *Absolute Maximum Ratings* may cause permanent damage to the device. These are stress ratings only, which do not imply functional operation of the device at these or any other conditions beyond those indicated under *Recommended Operating Conditions*. Exposure to absolute-maximum-rated conditions for extended periods may affect device reliability.
- (2) All voltage values are with respect to ground.

6.2 ESD Ratings

			VALUE	UNIT	
V _(ESD)	Electrostatic discharge	Human-body model (HBM), per AEC Q100-002 ⁽¹⁾	±2000	V	
		Charged-device model (CDM), per AEC Q100-011	All pins		±500
			Corner pins (1, 14, 15, and 28)		±750

(1) AEC Q100-002 indicates that HBM stressing shall be in accordance with the ANSI/ESDA/JEDEC JS-001 specification.

6.3 Recommended Operating Conditions

over operating ambient temperature range (unless otherwise noted)

		MIN	MAX	UNIT
Unregulated input	IN	4	40	V
40-V pins	EN, FSEL, WTS	0	V _{IN}	V
Regulated output	OUT	0	5.5	V
Power good, watchdog status, reference oscillator	PG, WDO, ROSC	0	5.5	V
Low voltage pins	WD, $\overline{\text{WD_EN}}$, PGADJ, DELAY, WRS	0	5.5	V
Output current		0	500	mA
Operating junction temperature, T _J		−40	150	°C
Ambient temperature, T _A		−40	125	°C

6.4 Thermal Information

THERMAL METRIC ⁽¹⁾		TPS7B68-Q1	UNIT
		PWP (HTSSOP)	
		28 PINS	
R _{θJA}	Junction-to-ambient thermal resistance	37.8	°C/W
R _{θJC(top)}	Junction-to-case (top) thermal resistance	18.4	°C/W
R _{θJB}	Junction-to-board thermal resistance	18.7	°C/W
Ψ _{JT}	Junction-to-top characterization parameter	0.8	°C/W
Ψ _{JB}	Junction-to-board characterization parameter	18.5	°C/W
R _{θJC(bot)}	Junction-to-case (bottom) thermal resistance	2.4	°C/W

(1) For more information about traditional and new thermal metrics, see the [Semiconductor and IC Package Thermal Metrics application report](#).

6.5 Electrical Characteristics

 $V_{IN} = 14\text{ V}$, $C_{OUT} \geq 4.7\text{ }\mu\text{F}$, $1\text{ m}\Omega < \text{ESR} < 20\text{ }\Omega$, and $T_J = -40^\circ\text{C}$ to 150°C (unless otherwise noted)

PARAMETER		TEST CONDITIONS	MIN	TYP	MAX	UNIT
SUPPLY VOLTAGE AND CURRENT (IN)						
V_{IN}	Input voltage		4		40	V
$I_{(SLEEP)}$	Input sleep current	EN = OFF			4	μA
$I_{(Q)}$	Input quiescent current	$V_{IN} = 5.6\text{ V}$ to 40 V for fixed 5-V V_{OUT} ; $V_{IN} = 4\text{ V}$ to 40 V for fixed 3.3-V V_{OUT} ; EN = ON; watchdog disabled; $I_{OUT} < 1\text{ mA}$; $T_J < 80^\circ\text{C}$		19	29.6	μA
		$V_{IN} = 5.6\text{ V}$ to 40 V for fixed 5-V V_{OUT} ; $V_{IN} = 4\text{ V}$ to 40 V for fixed 3.3-V V_{OUT} ; EN = ON; watchdog enabled; $I_{OUT} < 1\text{ mA}$		28	42	
		$V_{IN} = 5.6\text{ V}$ to 40 V for fixed 5-V V_{OUT} ; $V_{IN} = 4\text{ V}$ to 40 V for fixed 3.3-V V_{OUT} ; EN = ON; watchdog enabled; $I_{OUT} < 100\text{ mA}$		78	98	
$V_{(UVLO)}$	Undervoltage lockout, falling	Ramp V_{IN} down until output is turned off			2.6	V
$V_{(UVLO_HYST)}$	UVLO hysteresis			0.5		V
ENABLE INPUT, WATCHDOG TYPE SELECTION AND FSEL (EN, WTS, AND FSEL)						
V_{IL}	Low-level input voltage				0.7	V
V_{IH}	High-level input voltage		2			V
V_{hys}	Hysteresis			150		mV
WATCHDOG ENABLE ($\overline{\text{WD_EN}}$ PIN)						
V_{IL}	Low-level input threshold voltage for watchdog enable pin	Watchdog enabled			0.7	V
V_{IH}	High-level input threshold voltage for watchdog enable pin	Watchdog disabled	2			V
$I_{\overline{\text{WD_EN}}}$	Pulldown current for watchdog enable pin	$V_{\overline{\text{WD_EN}}} = 5\text{ V}$			3	μA
REGULATED OUTPUT (OUT)						
V_{OUT}	Regulated output	$V_{IN} = V_{OUT} + 1\text{ V}$ to 40 V , $I_{OUT} = 0$ to 500 mA	-2%		2%	
		$V_{IN} = 5.4\text{ V}$, $I_{OUT} = 250\text{ mA}$, $T_J = -40^\circ\text{C}$ to 85°C	-2%		2%	
$\Delta V_{OUT}(\Delta V_{IN})$	Line regulation	$V_{IN} = 5.6\text{ V}$ to 40 V			10	mV
$\Delta V_{OUT}(\Delta I_{OUT})$	Load regulation	$I_{OUT} = 1\text{ mA}$ to 500 mA			20	mV
$V_{(dropout)}$	Dropout voltage ($V_{IN} - V_{OUT}$) ⁽¹⁾	$I_{OUT} = 500\text{ mA}$		350	800	mV
		$I_{OUT} = 200\text{ mA}$ ⁽²⁾		170	325	
I_{OUT}	Output current	V_{OUT} in regulation	0		500	mA
$I_{(LIM)}$	Output short-circuit current limit	V_{OUT} shorted to ground, $V_{IN} = 5.6\text{ V}$, TPS7B6850QPWPRQ1	550	690	1000	mA
		V_{OUT} shorted to ground, $V_{IN} = 5.6\text{ V}$, TPS7B6833QPWPRQ1	490	690	1000	
PSRR	Power supply ripple rejection ⁽³⁾	$I_{OUT} = 100\text{ mA}$; $C_{OUT} = 10\text{ }\mu\text{F}$; frequency (f) = 100 Hz		60		dB
		$I_{OUT} = 100\text{ mA}$; $C_{OUT} = 10\text{ }\mu\text{F}$; frequency (f) = 100 kHz		40		

(1) This test is done with V_{OUT} in regulation, measuring the $V_{IN} - V_{OUT}$ when V_{OUT} drops by 100 mV from the rated output voltage at the specified load.

(2) Dropout is not measured for $V_{OUT} = 3.3\text{ V}$ in this test because V_{IN} must be 4 V or greater for proper operation.

(3) Design Information – Not tested, determined by characterization.

Electrical Characteristics (continued)
 $V_{IN} = 14\text{ V}$, $C_{OUT} \geq 4.7\text{ }\mu\text{F}$, $1\text{ m}\Omega < \text{ESR} < 20\text{ }\Omega$, and $T_J = -40^\circ\text{C}$ to 150°C (unless otherwise noted)

PARAMETER		TEST CONDITIONS	MIN	TYP	MAX	UNIT
POWER GOOD (PG, PGADJ)						
$V_{OL(PG)}$	PG output, low voltage	$I_{OL} = 5\text{ mA}$, PG pulled low			0.4	V
$I_{lkg(PG)}$	PG pin leakage current	PG pulled to V_{OUT} through a 10-k Ω resistor			1	μA
$V_{(PG_TH)}$ rising	Default power-good threshold	V_{OUT} powered above the internally set tolerance, PGADJ pin shorted to ground	89.6	91.6	93.6	% of V_{OUT}
$V_{(PG_HYST)}$	Power-good hysteresis	V_{OUT} falling below the internally set tolerance hysteresis		2		% of V_{OUT}
PGADJ						
$V_{(PGADJ_TH)}$ falling	Switching voltage for the power-good adjust pin	V_{OUT} is falling	1.067	1.1	1.133	V
$V_{(PGADJ_HYST)}$	PGADJ hysteresis			26		mV
POWER-GOOD DELAY						
$I_{(DLY_CHG)}$	DELAY capacitor charging current		3	5	10	μA
$V_{(DLY_TH)}$	DELAY pin threshold to release PG high	Voltage at DELAY pin is ramped up	0.95	1	1.05	V
$I_{(DLY_DIS)}$	DELAY capacitor discharging current	$V_{DELAY} = 1\text{ V}$	0.5			mA
CURRENT VOLTAGE REFERENCE (ROSC)						
V_{ROSC}	Voltage reference		0.95	1	1.05	V
WATCHDOG (WD, WDO, WRS)						
V_{IL}	Low-level threshold voltage for the watchdog input and window-ratio select	For WD and WRS pins			30	% of V_{OUT}
V_{IH}	High-level threshold voltage for the watchdog input and window-ratio select	For WD and WRS pins	70			% of V_{OUT}
$V_{(HYST)}$	Hysteresis			10		% of V_{OUT}
I_{WD}	Pulldown current for the WD pin	$V_{WDO} = 5\text{ V}$		2	4	μA
V_{OL}	Watchdog output pulled low	$I_{WDO} = 5\text{ mA}$			0.4	V
I_{lkg}	WDO pin leakage current	WDO pin pulled to V_{OUT} through 10-k Ω resistor			1	μA
OPERATING TEMPERATURE RANGE						
T_J	Junction temperature		-40		150	$^\circ\text{C}$
$T_{(SD)}$	Junction shutdown temperature			175		$^\circ\text{C}$
$T_{(HYST)}$	Hysteresis of thermal shutdown			25		$^\circ\text{C}$

6.6 Switching Characteristics

 $V_I = 14\text{ V}$, $C_O \geq 4.7\text{ }\mu\text{F}$, $1\text{ m}\Omega < \text{ESR} < 20\text{ }\Omega$, and $T_J = -40^\circ\text{C}$ to 150°C (unless otherwise noted)

PARAMETER		TEST CONDITIONS	MIN	TYP	MAX	UNIT
POWER-GOOD DELAY (DELAY)						
$t_{(\text{DEGLITCH})}$	Power-good deglitch time		55	180	250	μs
$t_{(\text{DLY_FIX})}$	Fixed power-good delay	No capacitor connect at DELAY pin		248	900	μs
$t_{(\text{DLY})}$	Power-on-reset delay	Delay capacitor value: $C_{(\text{DELAY})} = 100\text{ nF}$		20		ms
WATCHDOG (WD, WDO, WRS)						
$t_{(\text{WD})}$	Watchdog window duration	$R_{(\text{ROSC})} = 20\text{ k}\Omega \pm 1\%$, FSEL = LOW	9	10	11	ms
		$R_{(\text{ROSC})} = 20\text{ k}\Omega \pm 1\%$, FSEL = HIGH	45	50	55	
$t_{(\text{WD_TOL})}$	Tolerance of watchdog window duration using external resistor	$R_{(\text{ROSC})} = 20\text{ k}\Omega \pm 1\%$ to $50\text{ k}\Omega \pm 1\%$	-10%		10%	
$t_{p(\text{WD})}$	Watchdog service-signal duration		100			μs
$t_{(\text{WD_HOLD})}$	Watchdog output resetting time (percentage of settled watchdog window duration)			20		% of $t_{(\text{WD})}$
$t_{(\text{WD_RESET})}$	Watchdog output resetting time	$R_{(\text{ROSC})} = 20\text{ k}\Omega \pm 1\%$, FSEL = LOW	1.8	2	2.2	ms
		$R_{(\text{ROSC})} = 20\text{ k}\Omega \pm 1\%$, FSEL = HIGH	9	10	11	

6.7 Typical Characteristics

$V_{IN} = 14\text{ V}$, $V_{EN} \geq 2\text{ V}$, $T_J = -40^\circ\text{C}$ to $+150^\circ\text{C}$ (unless otherwise noted)



图 1. Quiescent Current vs Output Current



图 2. Quiescent Current vs Input Voltage

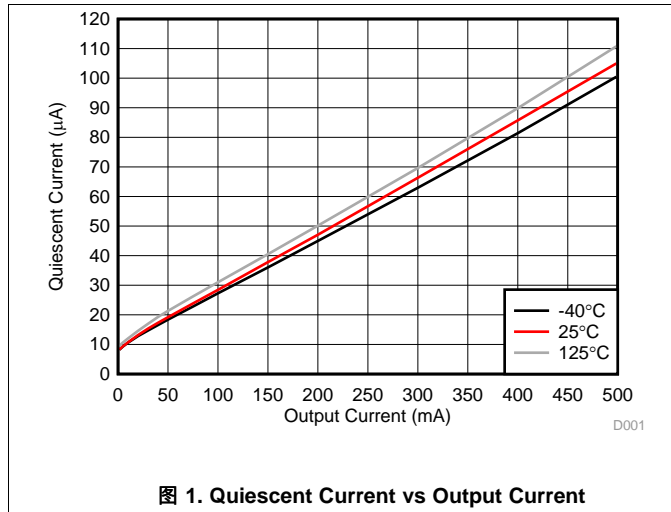

图 3. Shutdown Current vs Ambient Temperature

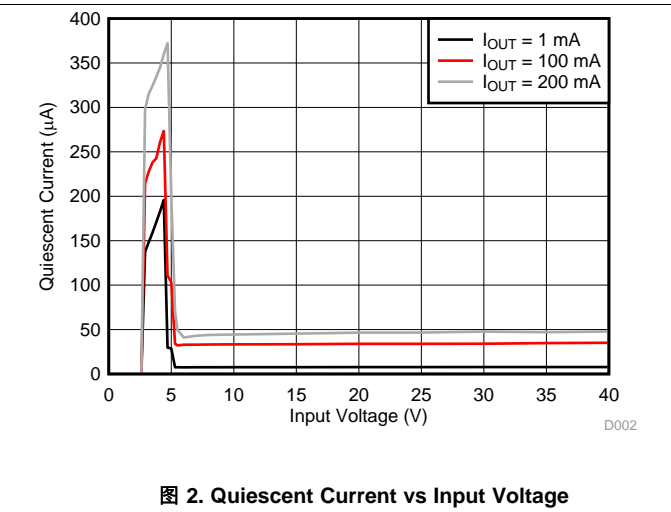

图 4. Quiescent Current vs Ambient Temperature

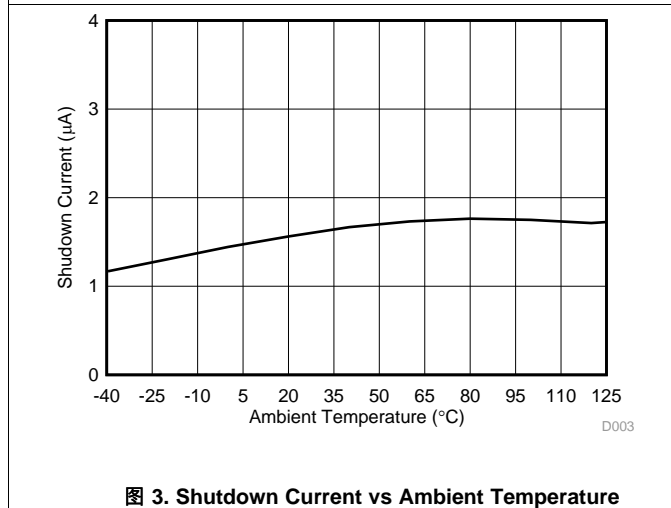

图 5. Dropout Voltage vs Output Current

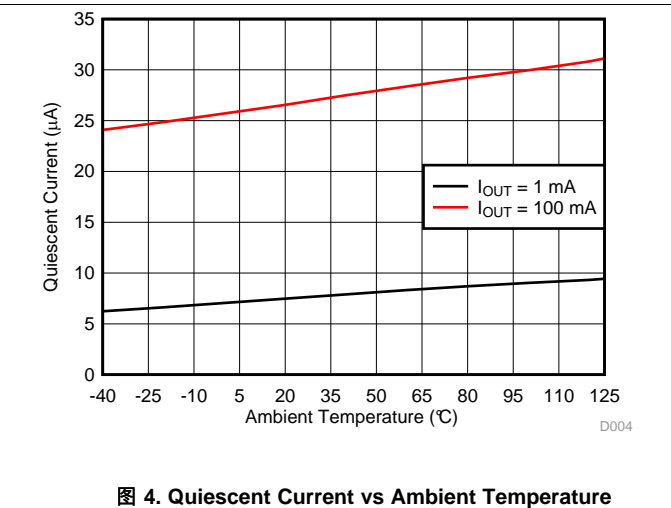

图 6. Dropout Voltage vs Ambient Temperature

Typical Characteristics (接下页)

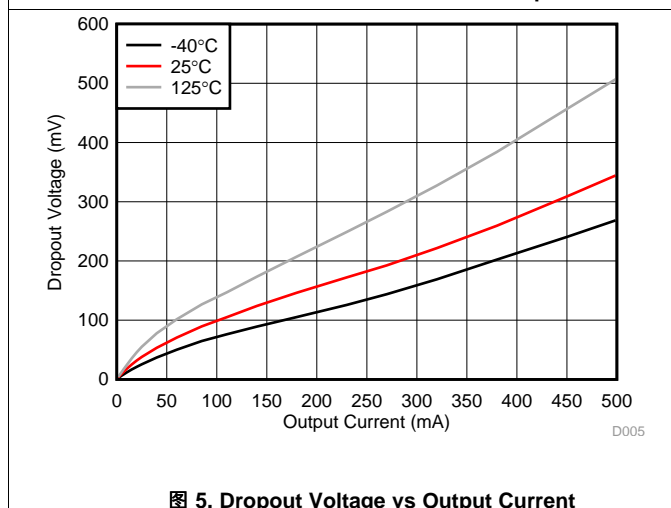
$V_{IN} = 14\text{ V}$, $V_{EN} \geq 2\text{ V}$, $T_J = -40^\circ\text{C}$ to $+150^\circ\text{C}$ (unless otherwise noted)

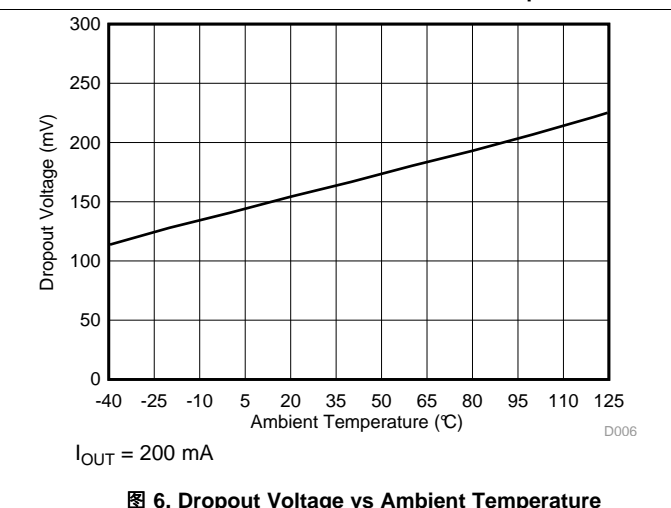

图 7. Output Voltage vs Ambient Temperature



图 8. Output Voltage vs Input Voltage

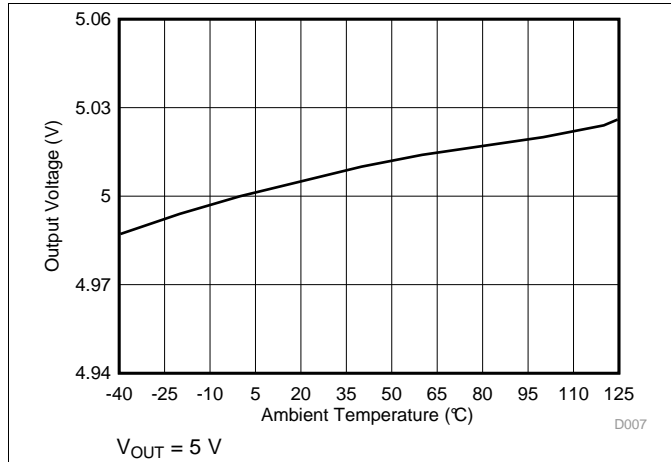

图 9. Output Current Limit (I_{LIM}) vs Ambient Temperature

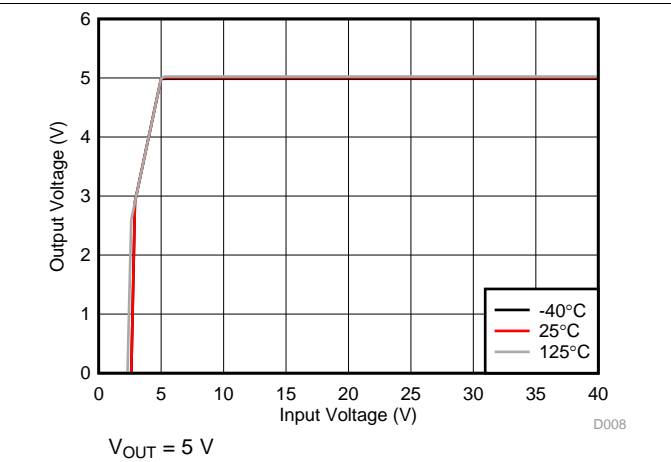

图 10. Load Regulation

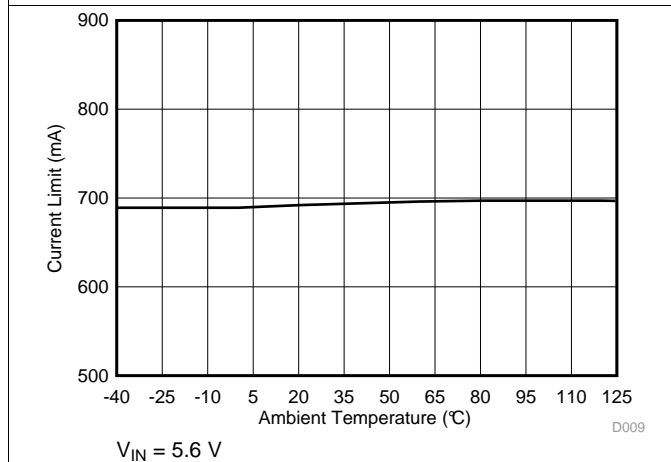

图 11. Line Regulation

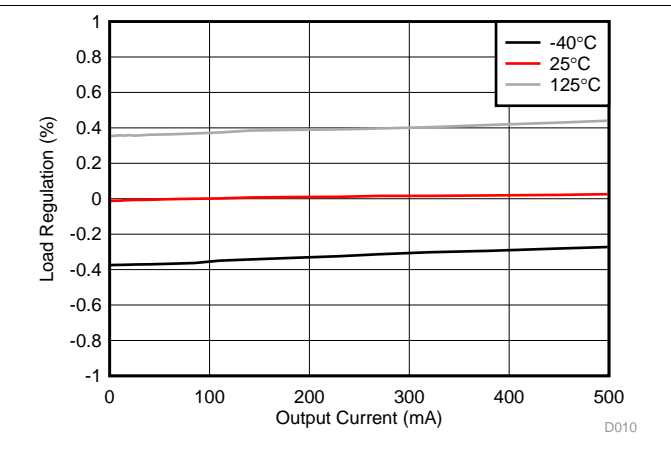

图 12. PSRR vs Frequency

Typical Characteristics (接下页)

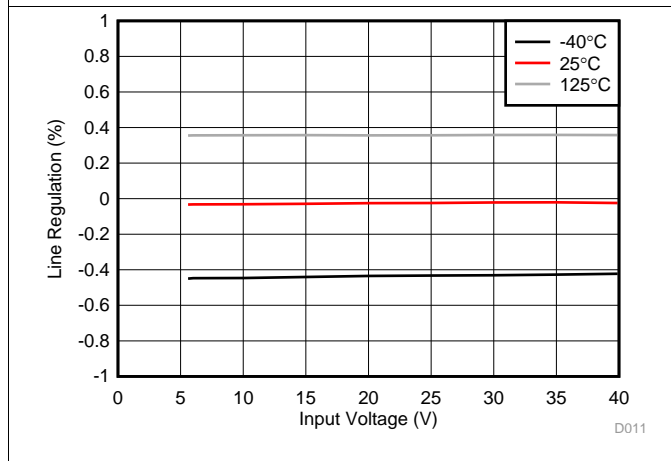
$V_{IN} = 14\text{ V}$, $V_{EN} \geq 2\text{ V}$, $T_J = -40^\circ\text{C}$ to $+150^\circ\text{C}$ (unless otherwise noted)

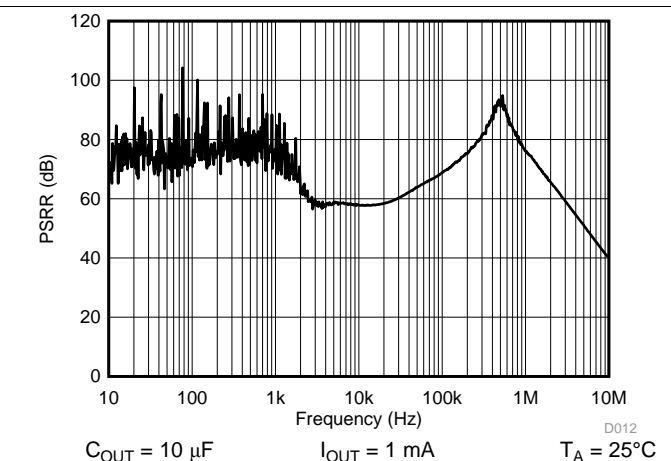

图 13. PSRR vs Frequency



图 14. ESR Stability vs Output Capacitance

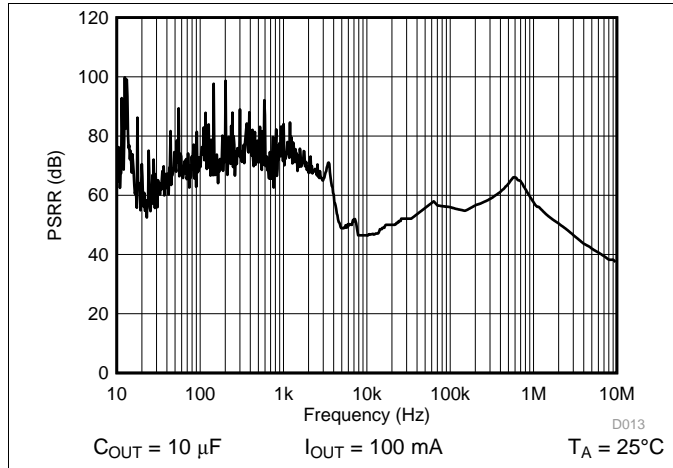

图 15. Line Transient

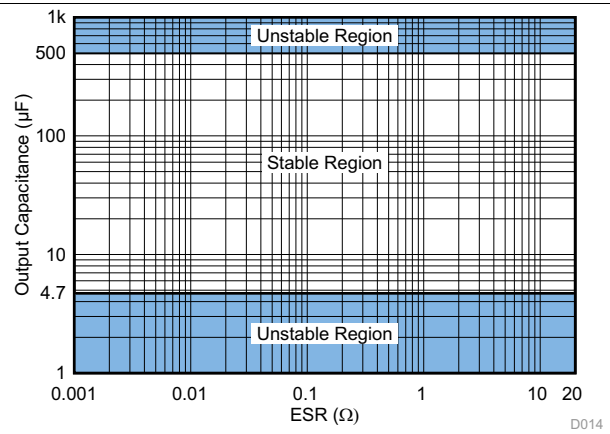

图 16. Line Transient

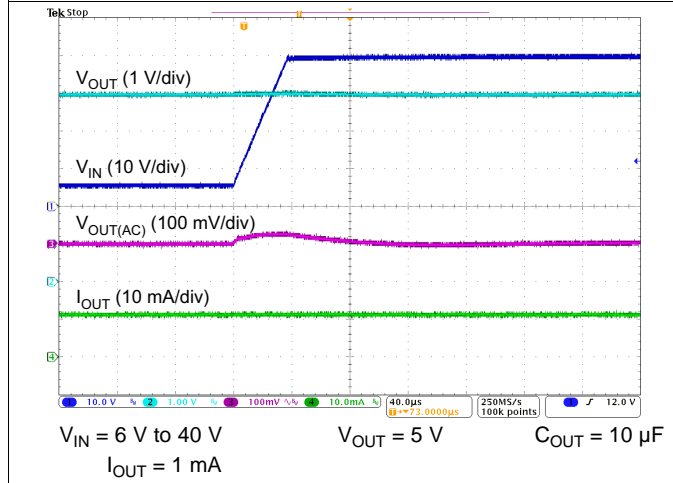

图 17. Line Transient

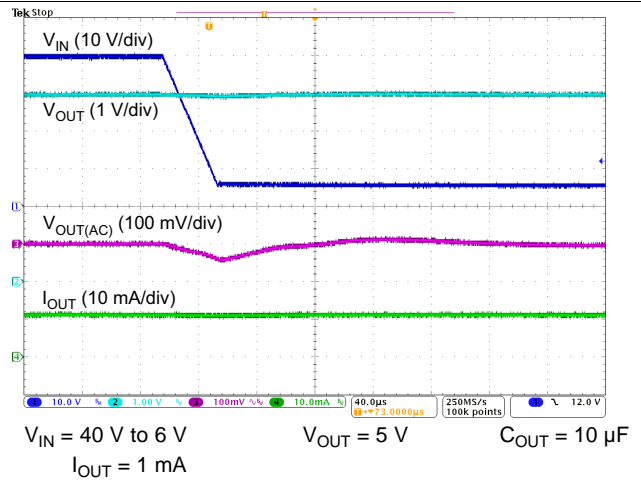

图 18. Line Transient

Typical Characteristics (接下页)

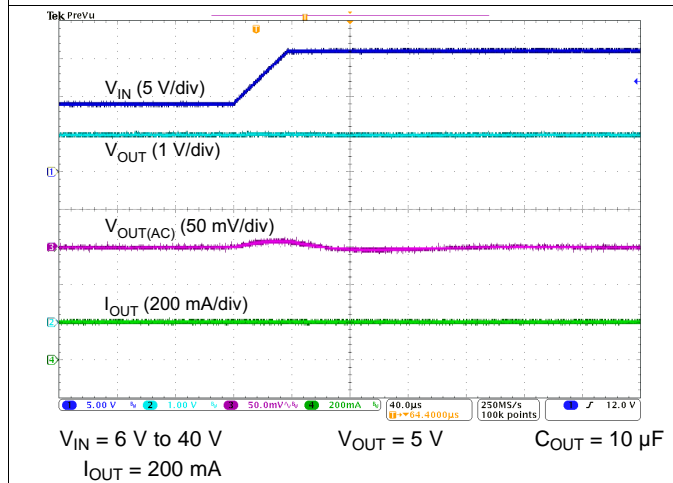
$V_{IN} = 14\text{ V}$, $V_{EN} \geq 2\text{ V}$, $T_J = -40^\circ\text{C}$ to $+150^\circ\text{C}$ (unless otherwise noted)

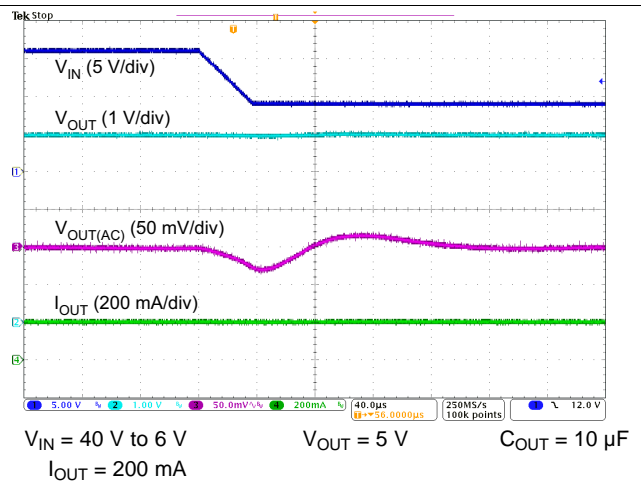

图 19. Load Transient



图 20. Load Transient

7 Detailed Description

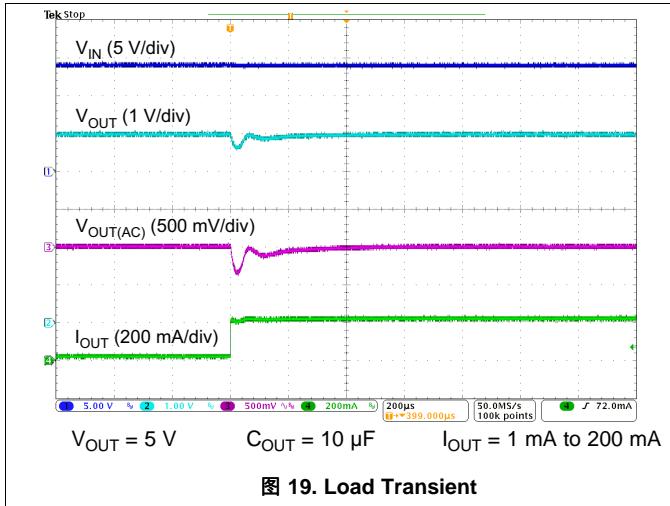
7.1 Overview

The TPS7B68-Q1 is a 500-mA, 40-V monolithic low-dropout linear voltage regulator with integrated watchdog and adjustable power-good threshold functionality. This voltage regulator consumes only 19- μ A quiescent current in light-load applications. Because of the adjustable power-good delay (also called power-on-reset delay) and the adjustable power-good threshold, this device is well-suited as power supplies for microprocessors and microcontrollers in automotive applications.

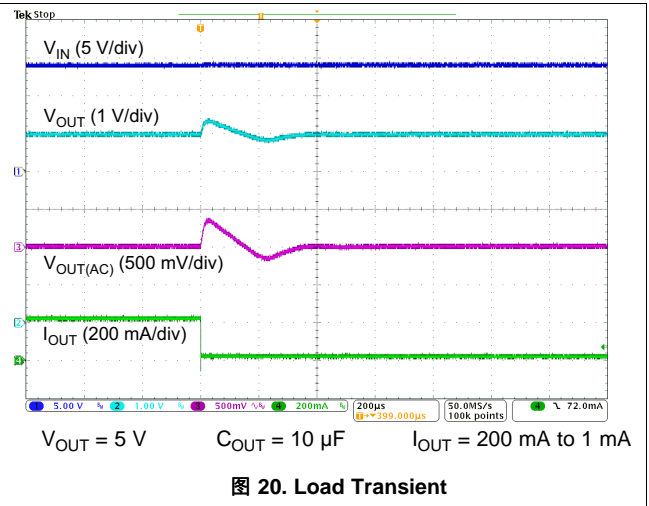
7.2 Functional Block Diagram

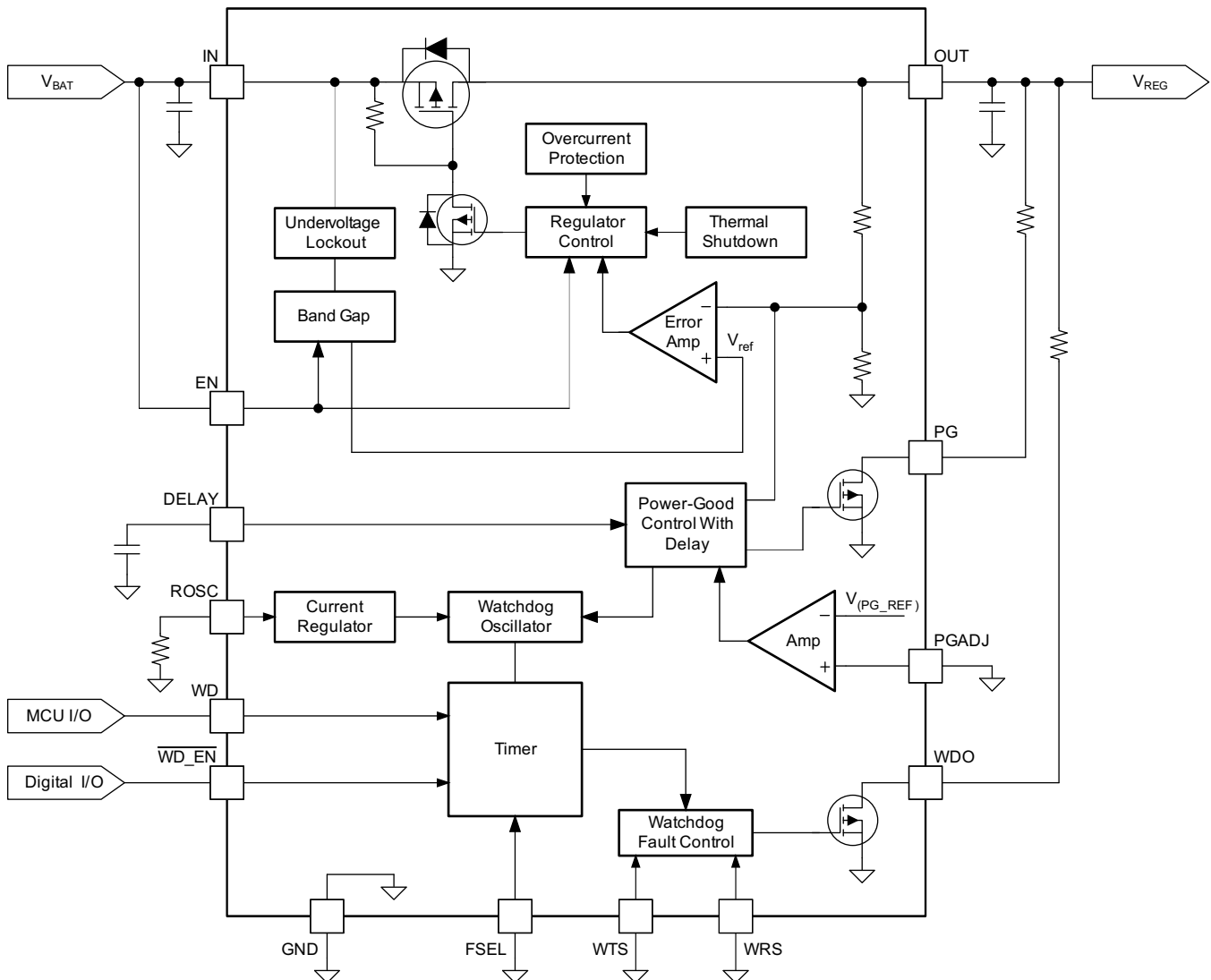

7.3 Feature Description

7.3.1 Device Enable (EN)

The EN pin is a high-voltage-tolerant pin. High input activates the devices and turns the regulators ON. Connect this input pin to an external microcontroller or a digital control circuit to enable and disable the devices, or connect to the IN pin for self-bias applications.

Feature Description (接下页)

7.3.2 Adjustable Power-Good Threshold (PG, PGADJ)

The PG pin is an open-drain output with an external pullup resistor to the regulated supply, and the PGADJ pin is a power-good threshold adjustment pin. Connecting the PGADJ pin to GND sets the power-good threshold value to the default, $V_{(PG_TH) \text{ rising}}$. When V_{OUT} exceeds the default power-good threshold, the PG output turns high after the power-good delay period has expired. When V_{OUT} falls below $V_{(PG_TH) \text{ rising}} - V_{(PG_HYST)}$, the PG output turns low after a short deglitch time.

The power-good threshold is also adjustable from 1.1 V to 5 V with external resistor divider between PGADJ and OUT. The threshold can be calculated using 公式 1:

$$V_{(PG_ADJ) \text{ falling}} = V_{(PGADJ_TH) \text{ falling}} \times \frac{R1+R2}{R2}$$

$$V_{(PG_ADJ) \text{ rising}} = \left[V_{(PGADJ_TH) \text{ falling}} + 26 \text{ mV (typ)} \right] \times \frac{R1+R2}{R2}$$

where

- $V_{(PG_ADJ) \text{ rising}}$, $V_{(PG_ADJ) \text{ falling}}$ is the adjustable power-good threshold
 - $V_{(PGADJ_TH) \text{ falling}}$ is the internal comparator reference voltage of the PGADJ pin, 1.1 V typical, 3% accuracy specified under all conditions
- (1)

By setting the power-good threshold $V_{(PG_ADJ) \text{ rising}}$, when V_{OUT} exceeds this threshold, the PG output turns high after the power-good delay period has expired. When V_{OUT} falls below $V_{(PG_ADJ) \text{ falling}}$, the PG output turns low after a short deglitch time.



图 21. Adjustable Power Good Threshold

7.3.3 Adjustable Power-Good Delay Timer (DELAY)

The power-good delay period is a function of the value set by an external capacitor on the DELAY pin before turning the PG pin high. Connecting an external capacitor from this pin to GND sets the power-good delay period. The constant current charges an external capacitor until the voltage exceeds a threshold to trip an internal comparator, and 公式 2 determines the power-good delay period:

$$t_{(DLY)} = \frac{C_{DELAY} \times 1 \text{ V}}{5 \mu\text{A}}$$

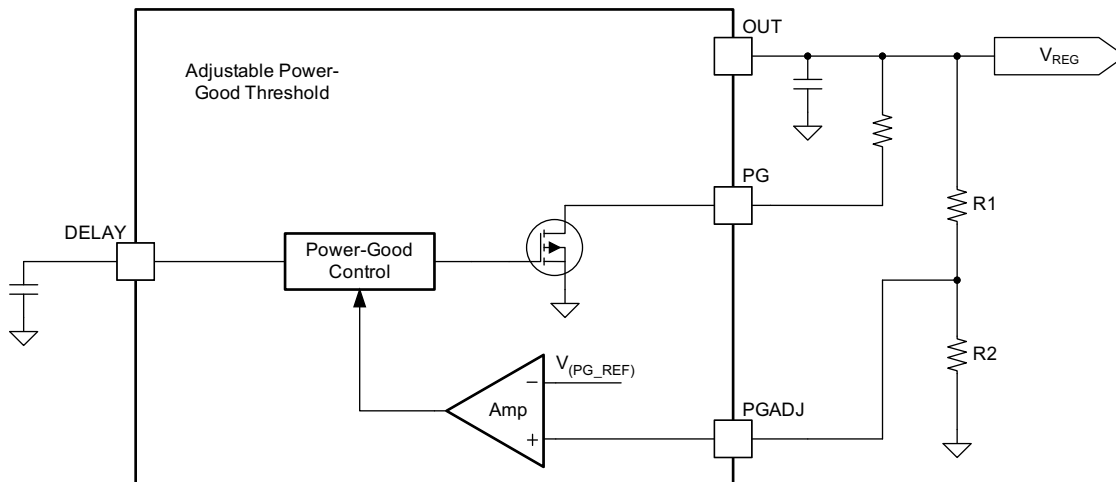
where

- $t_{(DLY)}$ is the adjustable power-good delay period
 - C_{DELAY} is the value of the power-good delay capacitor
- (2)

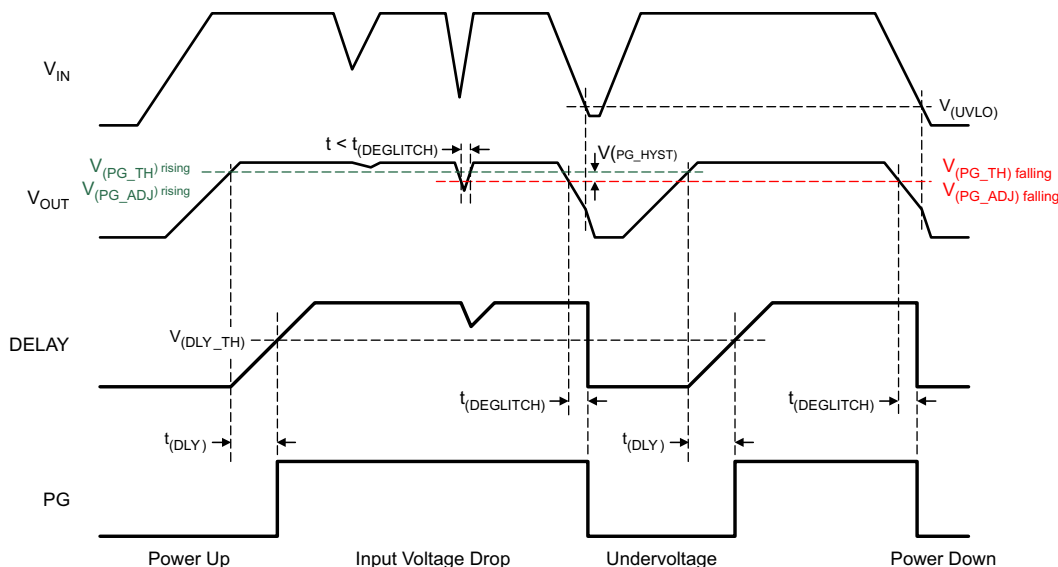
Feature Description (接下页)

NOTE: $V_{(PG_TH) \text{ falling}} = V_{(PG_TH) \text{ rising}} - V_{(PG_HYST)}$.

图 22. Power Up and Conditions for Activation of Power Good

If the DELAY pin is open, the default delay time is $t_{(DLY_FIX)}$.

7.3.4 Undervoltage Shutdown

This device has an integrated undervoltage lockout (UVLO) circuit to shut down the output if the input voltage falls below an internal UVLO threshold, $V_{(UVLO)}$. This ensures that the regulator does not latch into an unknown state during low input-voltage conditions. If the input voltage has a negative transient which drops below the UVLO threshold and recovers, the regulator shuts down and powers up with a normal power-up sequence when the input voltage is above the required levels.

7.3.5 Current Limit

This device features current-limit protection to keep the device in a safe operating area when an overload or output short-to-ground condition occurs. This protects the device from excessive power dissipation. For example, during a short-circuit condition on the output, fault protection limits the current through the pass element to $I_{(LIM)}$ to protect the device from excessive power dissipation.

7.3.6 Thermal Shutdown

This device incorporates a thermal shutdown (TSD) circuit as a protection from overheating. For continuous normal operation, the junction temperature should not exceed the thermal shutdown trip point. The junction temperature exceeding the TSD trip point causes the output to turn off. When the junction temperature falls below the $T_{(SD)} - T_{(HYST)}$, the output turns on again.

7.3.7 Integrated Watchdog

This device has an integrated watchdog with fault (WDO) output option. Both window watchdog and standard watchdog are available in one device. The watchdog operation, service fault conditions, and differences between window watchdog and standard watchdog are described as follows.

Feature Description (接下页)

7.3.7.1 Window Watchdog (WTS, ROSC, FSEL and WRS)

This device works in the window watchdog mode when the watchdog type selection (WTS) pin is connected to a low voltage level. The user can set the duration of the watchdog window by connecting an external resistor (R_{ROSC}) to ground at the ROSC pin and setting the voltage level at the FSEL pin. The current through the R_{ROSC} resistor sets the clock frequency of the internal oscillator. The user can adjust the duration of the watchdog window (the watchdog timer period) by changing the resistor value. A high voltage level at the FSEL pin sets the watchdog window duration to 5 times as long as that of a low voltage level with same external component configuration.

The duration of the watchdog window and the duration of the fault output are multiples of the internal oscillator frequency, as shown by the following equations:

$$\text{FSEL low} \quad t_{(WD)} = R_{ROSC} \times 0.5 \times 10^{-6} \quad (3)$$

$$\text{FSEL high} \quad t_{(WD)} = R_{ROSC} \times 2.5 \times 10^{-6} \quad (4)$$

$$\text{Watchdog initialization} \quad t_{(WD_INI)} = 8 \times t_{(WD)} \quad (5)$$

$$\text{Open and closed windows} \quad t_{(WD)} = t_{(OW)} + t_{(CW)} \quad (6)$$

$$\text{WRS low} \quad t_{(OW)} = t_{(CW)} = 50\% \times t_{(WD)} \quad (7)$$

$$\text{WRS high} \quad t_{(OW)} = 8 \times t_{(CW)} = (8 / 9) \times t_{(WD)} \quad (8)$$

where:

- $t_{(WD)}$ is the duration of the watchdog window
- R_{ROSC} is the resistor connected at the ROSC pin
- $t_{(WD_INI)}$ is the duration of the watchdog initialization
- $t_{(OW)}$ is the duration of the open watchdog window
- $t_{(CW)}$ is the duration of the closed watchdog window

For all the foregoing items, the unit of resistance is Ω and the unit of time is s.

表 1 illustrates several periods of watchdog window with typical conditions.

表 1. Several Typical Periods of Watchdog Window

FSEL	$R_{(ROSC)}$ (k Ω)	$I_{(ROSC)}$ (μ A)	$t_{(WD)}$ (ms)	WATCHDOG PERIOD TOLERANCE
High	200	5	500	15%
	100	10	250	
	50	20	125	10%
	40	25	100	
	25	40	62.5	
	20	50	50	
Low	100	10	50	10%
	50	20	25	
	40	25	20	
	25	40	12.5	
	20	50	10	

As shown in 图 23, each watchdog window consists of an open window and a closed window. While the window ratio selection (WRS) pin is low, each open window ($t_{(OW)}$) and closed window ($t_{(CW)}$) having a width approximately 50% of the watchdog window ($t_{(WD)}$). While the WRS pin is high, the ratio between open window and closed window is about 8:1. However, there is an exception to this; the first open window after watchdog initialization ($t_{(WD_INI)}$) is eight times the duration of the watchdog window. The watchdog must receive the service signal (by software, external microcontroller, and so forth) during this initialization open window.

A watchdog fault occurs when servicing the watchdog during a closed window, or not servicing during an open window.



图 23. Watchdog Initialization, Open Window and Closed Window

7.3.7.2 Standard Watchdog (WTS, ROSC and FSEL)

This device works in the standard watchdog mode when the watchdog type selection (WTS) pin is connected to a high voltage level. The same as in window watchdog mode, the user can set the duration of the watchdog window by adjusting the external resistor (R_{ROSC}) value at the ROSC pin and setting the voltage level at the FSEL pin. The current through the R_{ROSC} resistor sets the clock frequency of the internal oscillator. The user can adjust the duration of the watchdog window (the watchdog timer period) by changing the resistor value. A high voltage level at the FSEL pin sets the watchdog window duration to 5 times as long as that of a low voltage level with same external component configuration.

The duration of the watchdog window and the duration of the fault output are multiples of the internal oscillator frequency as shown by the following equations:

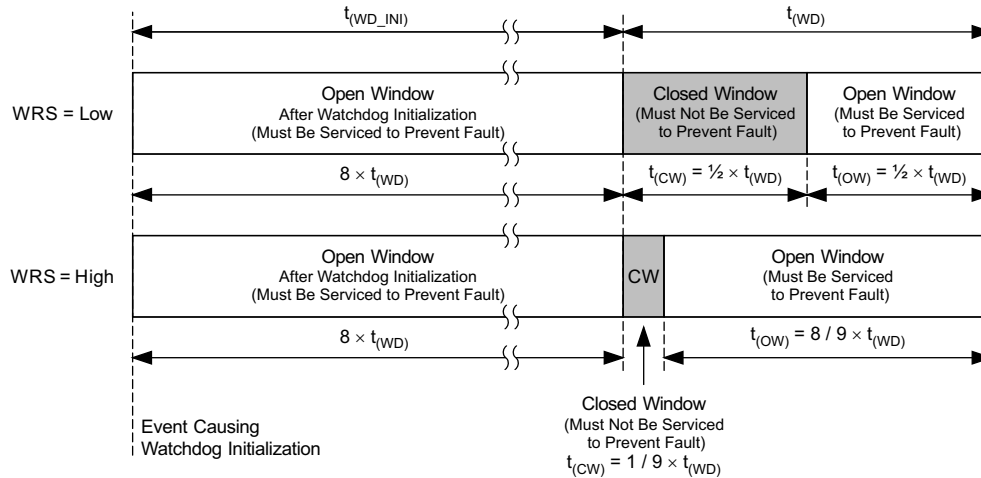
$$\text{FSEL low} \quad t_{(WD)} = R_{ROSC} \times 0.5 \times 10^{-6} \quad (9)$$

$$\text{FSEL high} \quad t_{(WD)} = R_{ROSC} \times 2.5 \times 10^{-6} \quad (10)$$

$$\text{Watchdog initialization} \quad t_{(WD_INI)} = 8 \times t_{(WD)} \quad (11)$$

where:

- $t_{(WD)}$ is the duration of the watchdog window
- R_{ROSC} is the resistor connected at the ROSC pin
- $t_{(WD_INI)}$ is the duration of the watchdog initialization

For all the foregoing items, the unit of resistance is Ω and the unit of time is s

Compared with window watchdog, there is no closed window in standard watchdog mode. The standard watchdog receives a service signal at any time within the watchdog window. The watchdog fault occurs when not servicing watchdog during the watchdog window.

7.3.7.3 Watchdog Service Signal and Watchdog Fault Outputs (WD and WDO)

The correct watchdog service signal (WD) must stay high for at least 100 μs . The WDO pin is the fault output terminal and is tied high through a pullup resistor to a regulated output supply. When a watchdog fault occurs, the device momentarily pulls WDO low for a duration of $t_{(WD_HOLD)}$.

$$t_{(WD_HOLD)} = 20\% \times t_{(WD)} \quad (12)$$

7.3.7.4 ROSC Status Detection (ROSC)

When a watchdog function is enabled, if the ROSC pin is shorted to GND or open, the watchdog output (WDO) pin remains low, indicating a fault status. If watchdog function is disabled, ROSC pin status detection does not work.

7.3.7.5 Watchdog Enable (PG and $\overline{WD_EN}$)

When PG (power good) is high, an external microcontroller or a digital circuit can apply a high or low logic signal to the $\overline{WD_EN}$ pin to disable or enable the watchdog. A low input to this pin turns the watchdog on, and a high input turns the watchdog off. If PG is low, the watchdog is disabled and the watchdog-fault output (WDO) pin stays in the high-impedance state.

7.3.7.6 Watchdog Initialization

On power up and during normal operation, the watchdog initializes under the conditions shown in [表 2](#).

表 2. Conditions for Watchdog Initialization

EDGE	WHAT CAUSES THE WATCHDOG TO INITIALIZE
↑	Rising edge of PG (power good) while the watchdog is in the enabled state, for example, during soft power up
↓	Falling edge of $\overline{WD_EN}$ while PG is already high, for example, when the microprocessor enables the watchdog after the device is powered up
↑	Rising edge of WDO while PG is already high and the watchdog is in the enabled state, for example, right after a closed window is serviced

7.3.7.7 Window Watchdog Operation (WTS = Low)

The window watchdog is able to monitor whether the frequency of the watchdog service signal (WD) is within certain ranges. A watchdog low-voltage fault is reported when the frequency of the watchdog service signal is out of the setting range. [图 24](#) shows the window watchdog initialization and operation for the TPS7B68-Q1 (WRS is low). After the output voltage is in regulation and PG is high, the window watchdog becomes enabled when an external signal pulls $\overline{WD_EN}$ (the watchdog enable pin) low. This causes the watchdog to initialize and wait for a service signal during the first initialization window for 8 times the duration of $t_{(WD)}$. A service signal applied to the WD pin during the initialization open window resets the watchdog counter and a closed window starts. To prevent a fault condition from occurring, watchdog service must not occur during the closed window. Watchdog service must occur during the following open window to prevent a fault condition from occurring. The fault output (WDO), externally pulled up to V_{OUT} (typical), stays high as long as the watchdog receives a proper service signal and there is no other fault condition.

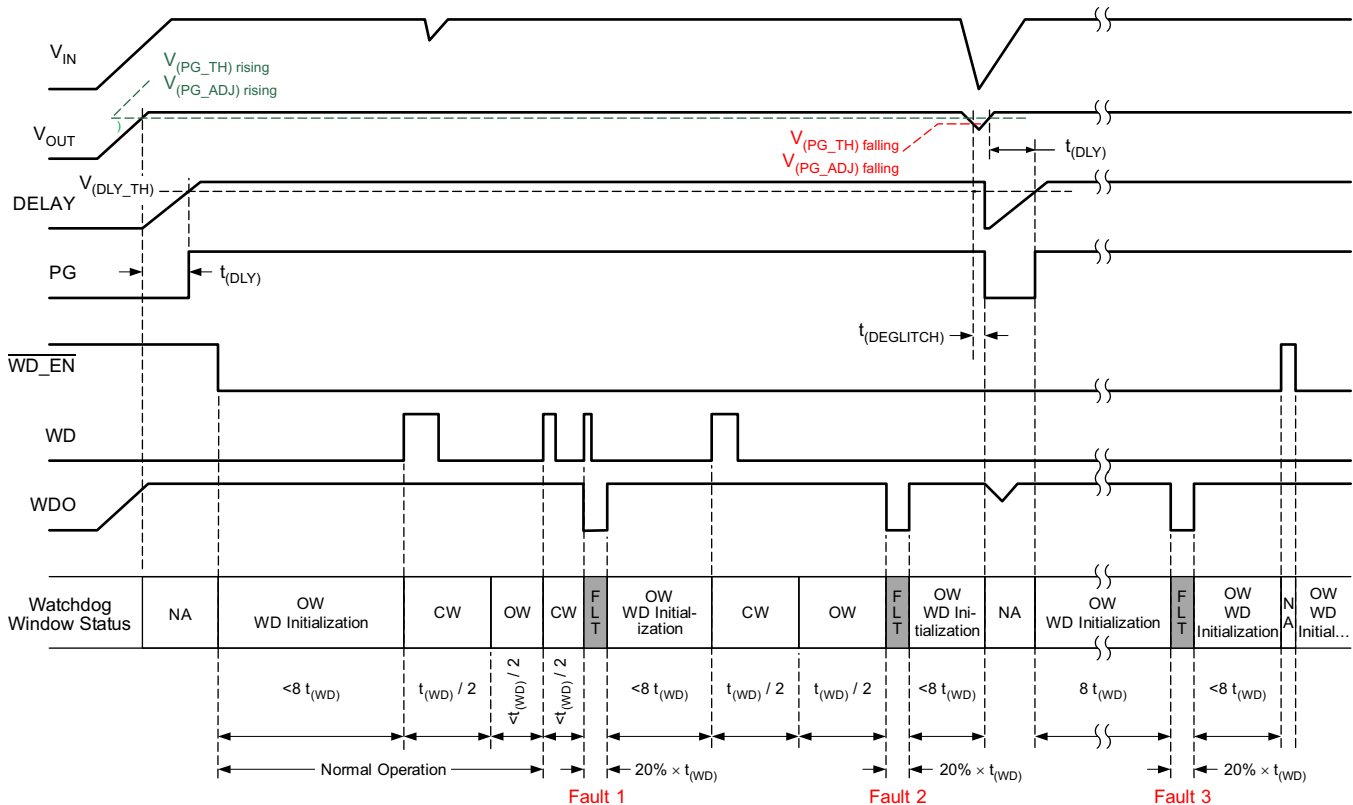

NOTE: $V_{(PG_TH) \text{ rising}} = V_{(PG_TH) \text{ falling}} + V_{(PG_HYST)}$.

图 24. Window Watchdog Operation

Three different fault conditions occur in 图 24:

- Fault 1: The watchdog service signal is received during the closed window. The WDO is triggered one time, receiving a WD rising edge during the closed window.
- Fault 2: The watchdog service signal is not received during the open window. WDO is triggered after the maximum open-window duration $t_{(WD)} / 2$.
- Fault 3: The watchdog service signal is not received during the WD initialization. WDO is triggered after the maximum initialization window duration $8 \times t_{(WD)}$.

7.3.7.8 Standard Watchdog Operation (WTS = High)

The standard watchdog is able to monitor whether the frequency of the watchdog service signal (WD) is lower than a certain value. A watchdog low-voltage fault is reported when the frequency of the watchdog service signal is lower than the set value.

图 25 shows the standard watchdog initialization and operation for the TPS7B68-Q1. Similar to the window watchdog, after output the voltage is in regulation and PG asserts high, the standard watchdog becomes enabled when an external signal pulls WD_EN low. This causes the standard watchdog to initialize and wait for a service signal during the first initialization window for 8 times the duration of $t_{(WD)}$. A service signal applied to the WD pin during the first open window resets the watchdog counter and another open window starts. To prevent a fault condition from occurring, watchdog service must occur during the every open window to prevent a fault condition from occurring. The fault output (WDO), externally pulled up to V_{OUT} (typical), stays high as long as the watchdog receives proper service and there is not fault condition.

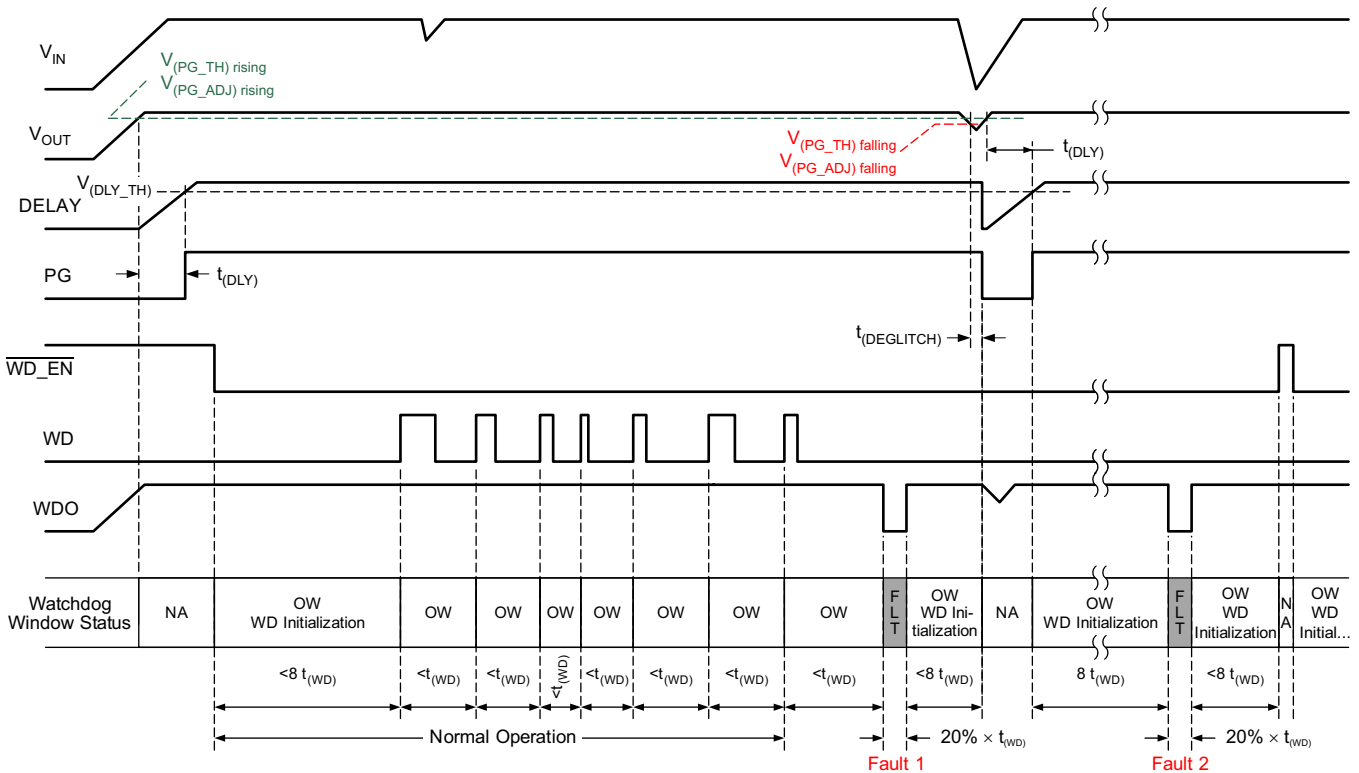

NOTE: $V_{(PG_TH) \text{ rising}} = V_{(PG_TH) \text{ falling}} + V_{(PG_HYST)}$.

图 25. Standard Watchdog Operation

Two different fault conditions occur in 图 25:

- Fault 1: The watchdog service signal is not received during the open window. WDO is triggered after the maximum open-window duration $t_{WD} / 2$.
- Fault 2: The watchdog service signal is not received during the WD initialization. WDO is triggered after the maximum initialization window duration $8 \times t_{WD}$.

7.4 Device Functional Modes

7.4.1 Operation With Input Voltage Lower Than 4 V

The device normally operates with input voltages above 4 V. The device can also operate at lower input voltages; the maximum UVLO voltage is 2.6 V. At input voltages below the actual UVLO voltage, the device does not operate.

7.4.2 Operation With Input Voltage Higher Than 4 V

When the input voltage is greater than 4 V, if the input voltage is higher than the output set value plus the device dropout voltage, then the output voltage is equal to the set value. Otherwise, the output voltage is equal to the input voltage minus the dropout voltage.

8 Application and Implementation

注

Information in the following applications sections is not part of the TI component specification, and TI does not warrant its accuracy or completeness. TI's customers are responsible for determining suitability of components for their purposes. Customers should validate and test their design implementation to confirm system functionality.

8.1 Application Information

The TPS7B68-Q1 device is a 500-mA low-dropout watchdog linear regulator with ultralow quiescent current. The PSpice transient model is available for download on the product folder and can be used to evaluate the basic function of the device.

8.2 Typical Application

图 26 shows a typical application circuit for the TPS7B68-Q1. Different values of external components can be used, depending on the end application. An application may require a larger output capacitor during fast load steps to prevent a large drop on the output voltage. TI recommends using a low-ESR ceramic capacitor with a dielectric of type X7R.



图 26. TPS7B68-Q1 Typical Application Schematic

Typical Application (接下页)

8.2.1 Design Requirements

For this design example, use the parameters listed in [表 3](#).

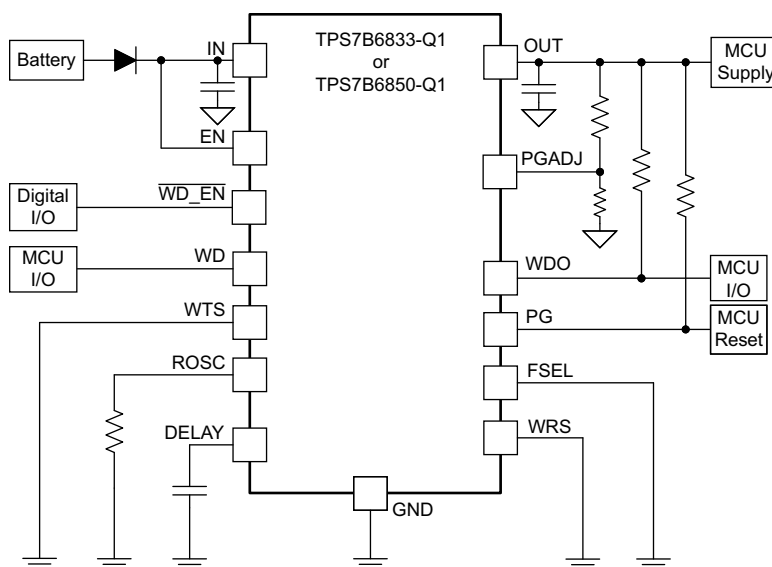
表 3. Design Parameters

DESIGN PARAMETER	EXAMPLE VALUES
Input voltage range	4 V to 40 V for TPS7B6833-Q1 5.6 V to 40 V for TPS7B6850-Q1
Input capacitor range	10 μ F to 22 μ F
Output voltage	3.3 V, 5 V
Output current rating	500 mA maximum
Output capacitor range	4.7 μ F to 500 μ F
Power-good threshold	Adjustable or fixed
Power-good delay capacitor	100 pF to 100 nF
Watchdog type	Standard watchdog or window watchdog
Watchdog window periods	10 ms to 500 ms

8.2.2 Detailed Design Procedure

To begin the design process, determine the following:

- Input voltage range
- Output voltage
- Output current
- Power-good threshold
- Power-good delay capacitor
- Watchdog type
- Watchdog window period

8.2.2.1 Input Capacitor

When using a TPS7B68-Q1 device, TI recommends adding a 10- μ F to 22- μ F capacitor with a 0.1 μ F ceramic bypass capacitor in parallel at the input to keep the input voltage stable. The voltage rating must be greater than the maximum input voltage.

8.2.2.2 Output Capacitor

Ensuring the stability of the TPS7B68-Q1 requires an output capacitor with a value in the range from 4.7 μ F to 500 μ F and with an ESR range from 0.001 Ω to 20 Ω . TI recommends selecting a ceramic capacitor with low ESR to improve the load transient response.

8.2.2.3 Power-Good Threshold

The power-good threshold is set by connecting PGADJ to GND or to a resistor divider from OUT to GND. The [Adjustable Power-Good Threshold \(PG, PGADJ\)](#) section provides the method for setup the power-good threshold.

8.2.2.4 Power-Good Delay Period

The power-good delay period is set by an external capacitor (C_{DELAY}) to ground, with a typical capacitor value from 100 pF to 100 nF. Calculate the correct capacitance for the application using [公式 2](#).

8.2.2.5 Watchdog Setup

The [Integrated Watchdog](#) section discusses the watchdog type selection and watchdog window-period setup method.

TPS7B68-Q1

ZHCSFR0C – MAY 2015 – REVISED FEBRUARY 2019

www.ti.com.cn

8.2.3 Application Curves



图 27. TPS7B6850-Q1 Power-Up Waveform



图 28. TPS7B6850-Q1 Watchdog Fault (High Frequency Watchdog Service Signal)

9 Power Supply Recommendations

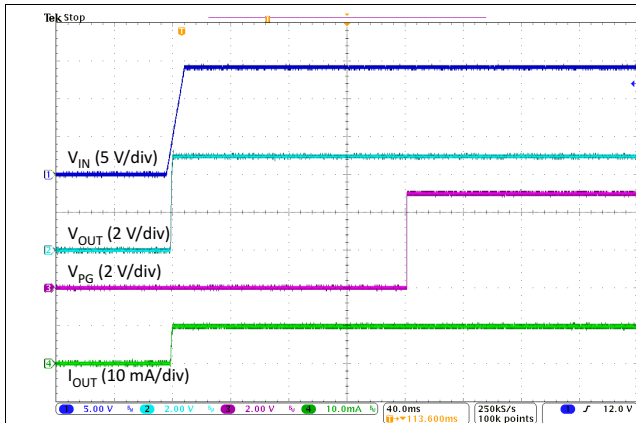
The device is designed to operate from an input-voltage supply range from 4 V to 40 V. This input supply must be well regulated. If the input supply is located more than a few inches from the TPS7B68-Q1 device, TI recommends adding a capacitor with a value of $\geq 10 \mu\text{F}$ with a $0.1 \mu\text{F}$ ceramic bypass capacitor in parallel at the input.

10 Layout

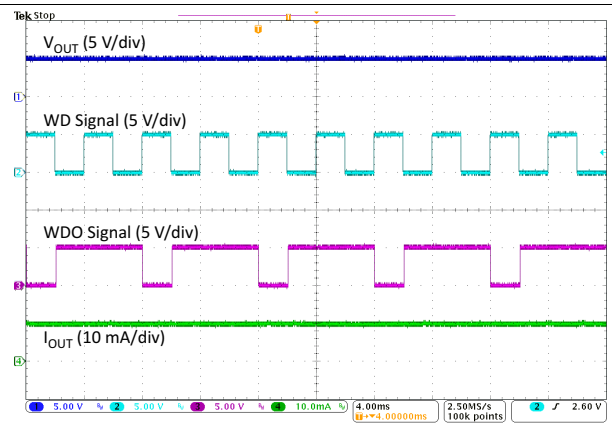
10.1 Layout Guidelines

For LDO power supplies, especially high-voltage and high-current ones, layout is an important step. If layout is not carefully designed, the regulator could not deliver enough output current because of thermal limitation. To improve the thermal performance of the device and maximize the current output at high ambient temperature, TI recommends spreading the thermal pad as much as possible and put enough thermal vias on the thermal pad. [图 29](#) shows an example layout.

10.2 Layout Example



图 29. Layout Recommendation

11 器件和文档支持

11.1 文档支持

11.1.1 相关文档

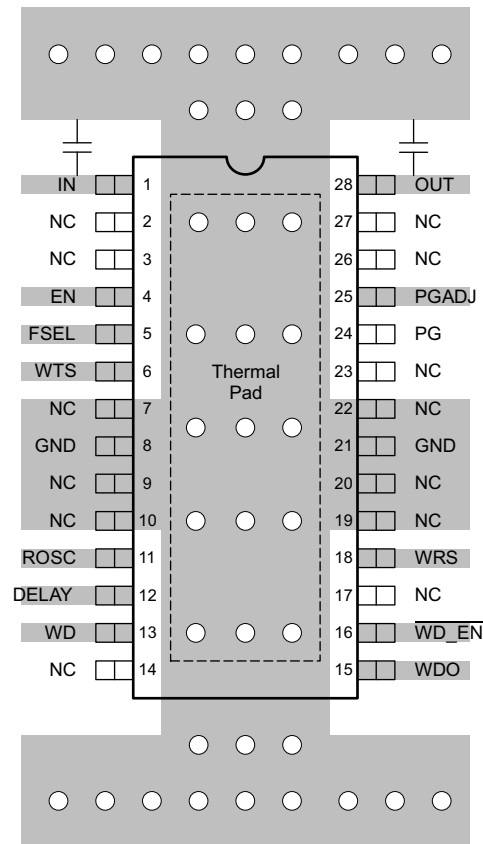
请参阅如下相关文档：

德州仪器 (TI)，《[TPS7B68-Q1 评估模块用户指南](#)》

11.2 接收文档更新通知

要接收文档更新通知，请导航至 TI.com.cn 上的器件产品文件夹。单击右上角的 [通知我](#) 进行注册，即可每周接收产品信息更改摘要。有关更改的详细信息，请查看任何已修订文档中包含的修订历史记录。

11.3 社区资源

下列链接提供到 TI 社区资源的连接。链接的内容由各个分销商“按照原样”提供。这些内容并不构成 TI 技术规范，并且不一定反映 TI 的观点；请参阅 TI 的 [《使用条款》](#)。

TI E2E™ Online Community *TI's Engineer-to-Engineer (E2E) Community*. Created to foster collaboration among engineers. At e2e.ti.com, you can ask questions, share knowledge, explore ideas and help solve problems with fellow engineers.

Design Support *TI's Design Support* Quickly find helpful E2E forums along with design support tools and contact information for technical support.

11.4 商标

PowerPAD, E2E are trademarks of Texas Instruments.
All other trademarks are the property of their respective owners.

11.5 静电放电警告



ESD 可能会损坏该集成电路。德州仪器 (TI) 建议通过适当的预防措施处理所有集成电路。如果不遵守正确的处理措施和安装程序，可能会损坏集成电路。

ESD 的损坏小至导致微小的性能降级，大至整个器件故障。精密的集成电路可能更容易受到损坏，这是因为非常细微的参数更改都可能会导致器件与其发布的规格不相符。

11.6 术语表

SLYZ022 — *TI 术语表*。

这份术语表列出并解释术语、缩写和定义。

12 机械、封装和可订购信息

以下页面包含机械、封装和可订购信息。这些信息是指定器件的最新可用数据。数据如有变更，恕不另行通知，且不会对此文档进行修订。如需获取此数据表的浏览器版本，请查看左侧的导航面板。

重要声明和免责声明

TI 均以“原样”提供技术性数据（包括数据表）、设计资源（包括参考设计）、应用或其他设计建议、网络工具、安全信息和其他资源，不保证其中不含任何瑕疵，且不做任何明示或暗示的担保，包括但不限于对适销性、适合某特定用途或不侵犯任何第三方知识产权的暗示担保。

所述资源可供专业开发人员应用TI 产品进行设计使用。您将对以下行为独自承担全部责任：(1) 针对您的应用选择合适的TI 产品；(2) 设计、验证并测试您的应用；(3) 确保您的应用满足相应标准以及任何其他安全、安保或其他要求。所述资源如有变更，恕不另行通知。TI 对您使用所述资源的授权仅限于开发资源所涉及TI 产品的相关应用。除此之外不得复制或展示所述资源，也不提供其它TI 或任何第三方的知识产权授权许可。如因使用所述资源而产生任何索赔、赔偿、成本、损失及债务等，TI 对此概不负责，并且您须赔偿由此对TI 及其代表造成的损害。

TI 所提供产品均受TI 的销售条款 (<http://www.ti.com.cn/zh-cn/legal/termsofsale.html>) 以及ti.com.cn上或随附TI产品提供的其他可适用条款的约束。TI提供所述资源并不扩展或以其他方式更改TI 针对TI 产品所发布的可适用的担保范围或担保免责声明。

邮寄地址：上海市浦东新区世纪大道 1568 号中建大厦 32 楼，邮政编码：200122
Copyright © 2019 德州仪器半导体技术（上海）有限公司

PACKAGING INFORMATION

Orderable Device	Status (1)	Package Type	Package Drawing	Pins	Package Qty	Eco Plan (2)	Lead finish/ Ball material (6)	MSL Peak Temp (3)	Op Temp (°C)	Device Marking (4/5)	Samples
TPS7B6833QPWPRQ1	ACTIVE	HTSSOP	PWP	28	2000	RoHS & Green	NIPDAU	Level-3-260C-168 HR	-40 to 125	7B6833Q	Samples
TPS7B6850QPWPRQ1	ACTIVE	HTSSOP	PWP	28	2000	RoHS & Green	NIPDAU	Level-3-260C-168 HR	-40 to 125	7B6850Q	Samples

(1) The marketing status values are defined as follows:

ACTIVE: Product device recommended for new designs.

LIFEBUY: TI has announced that the device will be discontinued, and a lifetime-buy period is in effect.

NRND: Not recommended for new designs. Device is in production to support existing customers, but TI does not recommend using this part in a new design.

PREVIEW: Device has been announced but is not in production. Samples may or may not be available.

OBSOLETE: TI has discontinued the production of the device.

(2) **RoHS:** TI defines "RoHS" to mean semiconductor products that are compliant with the current EU RoHS requirements for all 10 RoHS substances, including the requirement that RoHS substance do not exceed 0.1% by weight in homogeneous materials. Where designed to be soldered at high temperatures, "RoHS" products are suitable for use in specified lead-free processes. TI may reference these types of products as "Pb-Free".

RoHS Exempt: TI defines "RoHS Exempt" to mean products that contain lead but are compliant with EU RoHS pursuant to a specific EU RoHS exemption.

Green: TI defines "Green" to mean the content of Chlorine (Cl) and Bromine (Br) based flame retardants meet JS709B low halogen requirements of <=1000ppm threshold. Antimony trioxide based flame retardants must also meet the <=1000ppm threshold requirement.

(3) MSL, Peak Temp. - The Moisture Sensitivity Level rating according to the JEDEC industry standard classifications, and peak solder temperature.

(4) There may be additional marking, which relates to the logo, the lot trace code information, or the environmental category on the device.

(5) Multiple Device Markings will be inside parentheses. Only one Device Marking contained in parentheses and separated by a "~" will appear on a device. If a line is indented then it is a continuation of the previous line and the two combined represent the entire Device Marking for that device.

(6) Lead finish/Ball material - Orderable Devices may have multiple material finish options. Finish options are separated by a vertical ruled line. Lead finish/Ball material values may wrap to two lines if the finish value exceeds the maximum column width.

Important Information and Disclaimer:The information provided on this page represents TI's knowledge and belief as of the date that it is provided. TI bases its knowledge and belief on information provided by third parties, and makes no representation or warranty as to the accuracy of such information. Efforts are underway to better integrate information from third parties. TI has taken and continues to take reasonable steps to provide representative and accurate information but may not have conducted destructive testing or chemical analysis on incoming materials and chemicals. TI and TI suppliers consider certain information to be proprietary, and thus CAS numbers and other limited information may not be available for release.

In no event shall TI's liability arising out of such information exceed the total purchase price of the TI part(s) at issue in this document sold by TI to Customer on an annual basis.

TAPE AND REEL INFORMATION

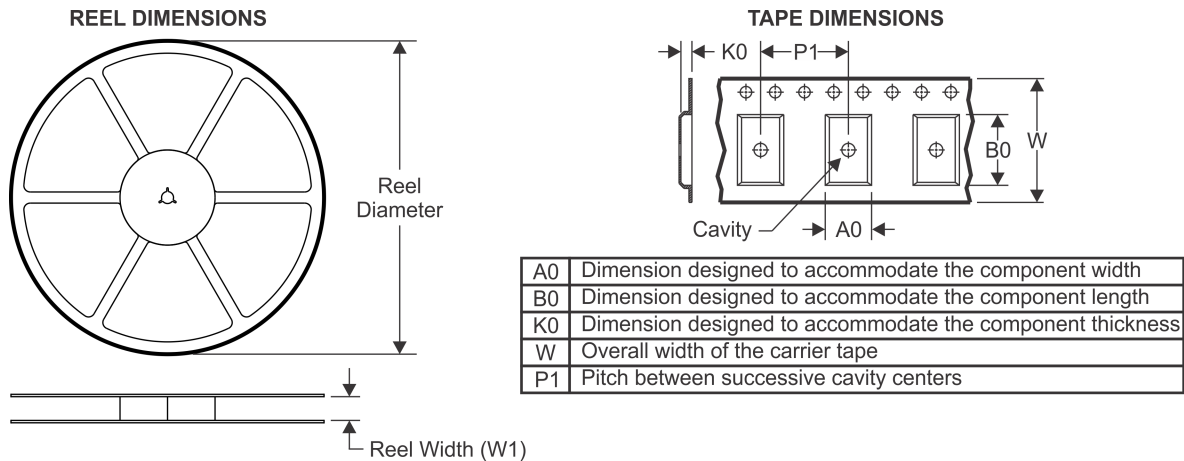

QUADRANT ASSIGNMENTS FOR PIN 1 ORIENTATION IN TAPE

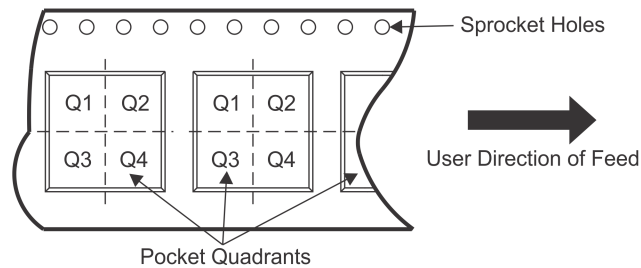

*All dimensions are nominal

Device	Package Type	Package Drawing	Pins	SPQ	Reel Diameter (mm)	Reel Width W1 (mm)	A0 (mm)	B0 (mm)	K0 (mm)	P1 (mm)	W (mm)	Pin1 Quadrant
TPS7B6833QPWPRQ1	HTSSOP	PWP	28	2000	330.0	16.4	6.9	10.2	1.8	12.0	16.0	Q1
TPS7B6850QPWPRQ1	HTSSOP	PWP	28	2000	330.0	16.4	6.9	10.2	1.8	12.0	16.0	Q1

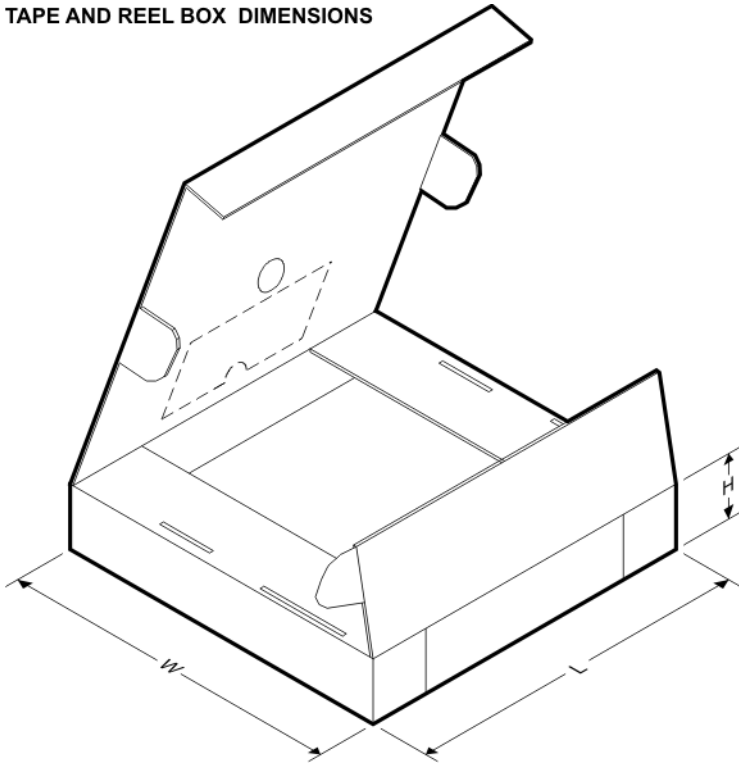
TAPE AND REEL BOX DIMENSIONS

*All dimensions are nominal

Device	Package Type	Package Drawing	Pins	SPQ	Length (mm)	Width (mm)	Height (mm)
TPS7B6833QPWRQ1	HTSSOP	PWP	28	2000	350.0	350.0	43.0
TPS7B6850QPWRQ1	HTSSOP	PWP	28	2000	350.0	350.0	43.0

GENERIC PACKAGE VIEW

PWP 28

PowerPAD™ TSSOP - 1.2 mm max height

4.4 x 9.7, 0.65 mm pitch

SMALL OUTLINE PACKAGE

This image is a representation of the package family, actual package may vary.
Refer to the product data sheet for package details.

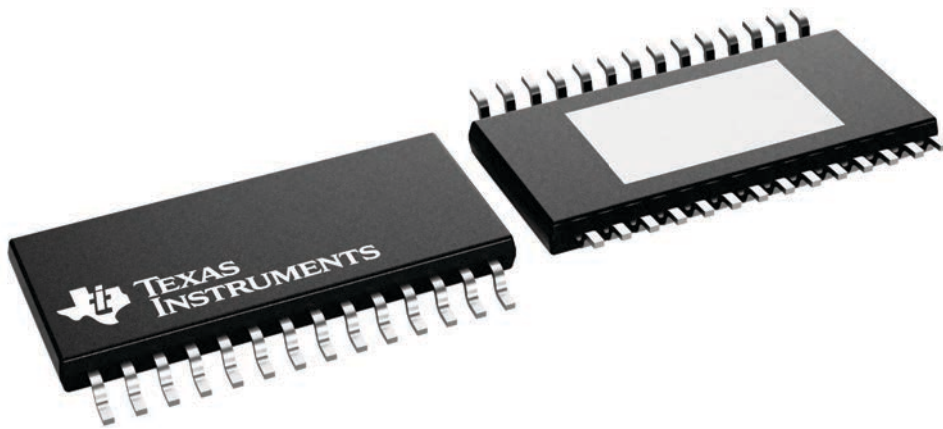

4224765/B

PWP0028C

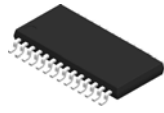

PACKAGE OUTLINE

PowerPAD™ TSSOP - 1.2 mm max height

SMALL OUTLINE PACKAGE

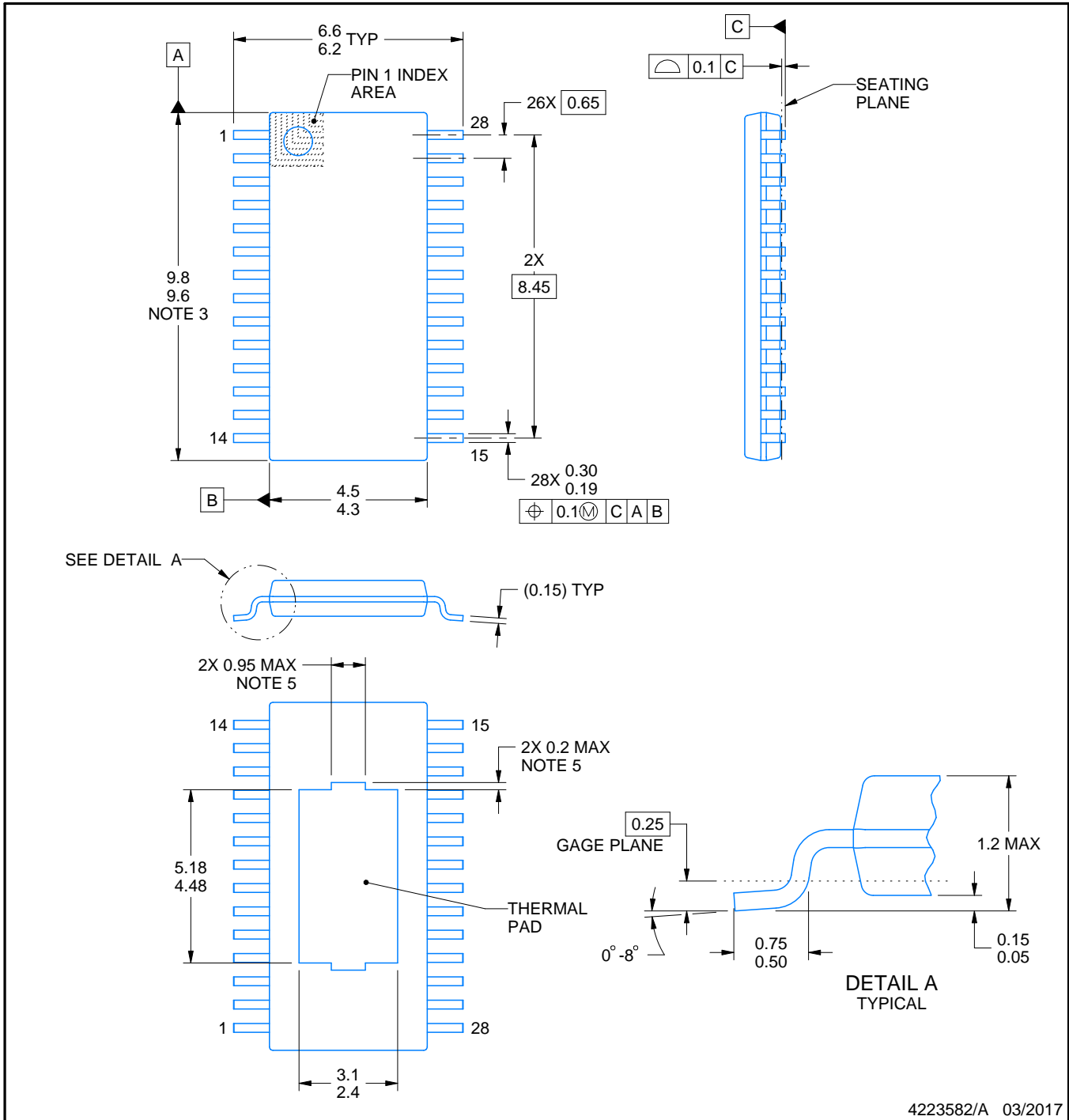

4223582/A 03/2017

NOTES:

PowerPAD is a trademark of Texas Instruments.

1. All linear dimensions are in millimeters. Any dimensions in parenthesis are for reference only. Dimensioning and tolerancing per ASME Y14.5M.
2. This drawing is subject to change without notice.
3. This dimension does not include mold flash, protrusions, or gate burrs. Mold flash, protrusions, or gate burrs shall not exceed 0.15 mm per side.
4. Reference JEDEC registration MO-153.
5. Features may differ or may not be present.

EXAMPLE BOARD LAYOUT

PWP0028C

PowerPAD™ TSSOP - 1.2 mm max height

SMALL OUTLINE PACKAGE

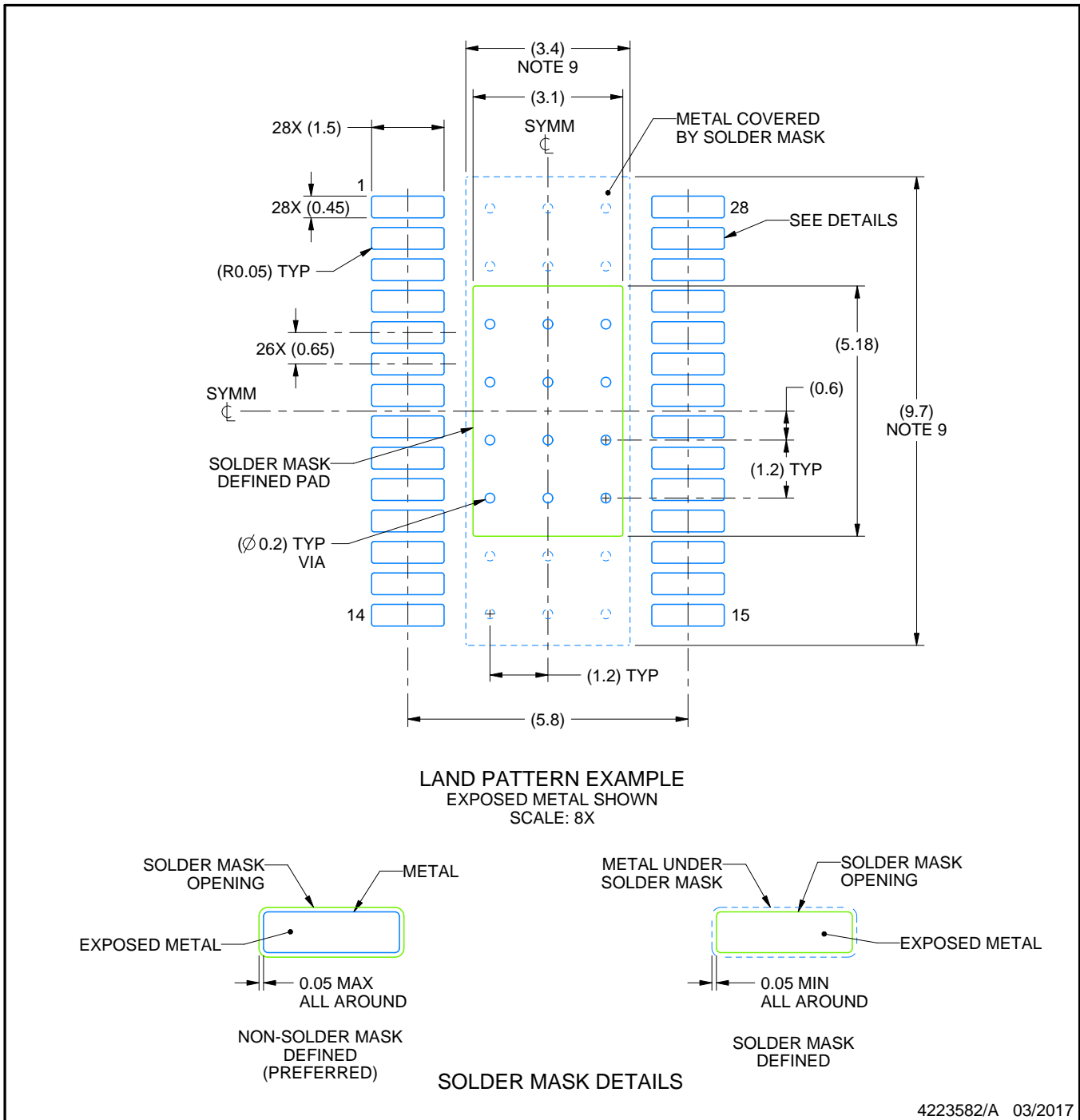

NOTES: (continued)

6. Publication IPC-7351 may have alternate designs.
7. Solder mask tolerances between and around signal pads can vary based on board fabrication site.
8. This package is designed to be soldered to a thermal pad on the board. For more information, see Texas Instruments literature numbers SLMA002 (www.ti.com/lit/slma002) and SLMA004 (www.ti.com/lit/slma004).
9. Size of metal pad may vary due to creepage requirement.
10. Vias are optional depending on application, refer to device data sheet. It is recommended that vias under paste be filled, plugged or tented.

EXAMPLE STENCIL DESIGN

PWP0028C

PowerPAD™ TSSOP - 1.2 mm max height

SMALL OUTLINE PACKAGE

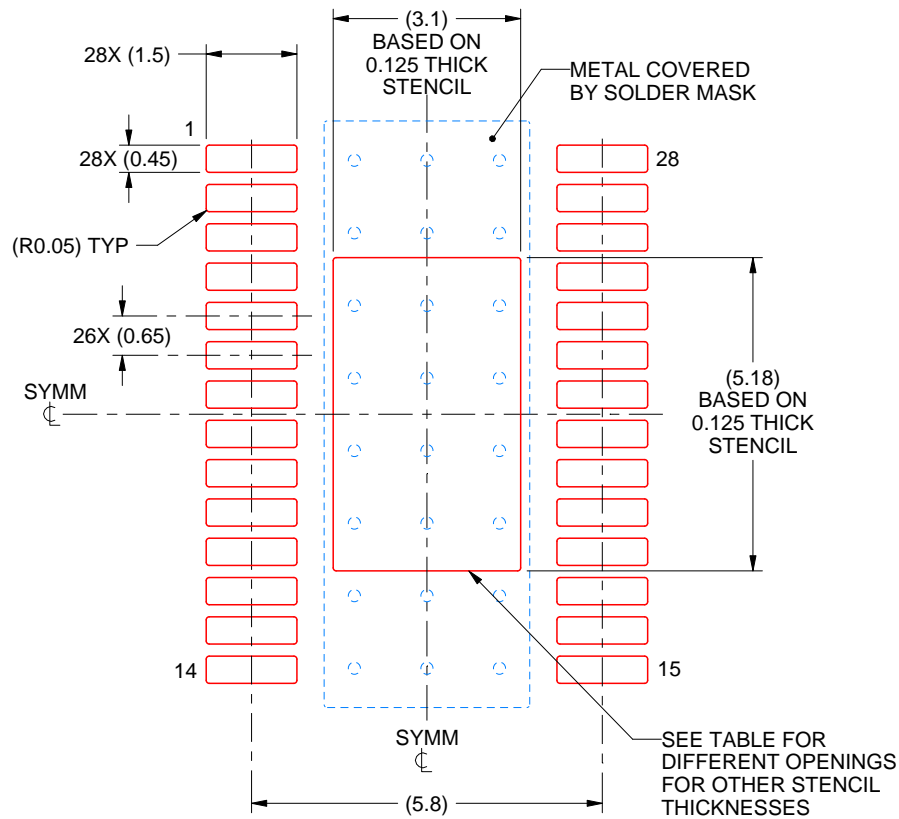

SOLDER PASTE EXAMPLE
 BASED ON 0.125 mm THICK STENCIL
 SCALE: 8X

STENCIL THICKNESS	SOLDER STENCIL OPENING
0.1	3.47 X 5.79
0.125	3.10 X 5.18 (SHOWN)
0.15	2.83 X 4.73
0.175	2.62 X 4.38

4223582/A 03/2017

NOTES: (continued)

11. Laser cutting apertures with trapezoidal walls and rounded corners may offer better paste release. IPC-7525 may have alternate design recommendations.
12. Board assembly site may have different recommendations for stencil design.

重要声明和免责声明

TI 均以“原样”提供技术性及其可靠性数据（包括数据表）、设计资源（包括参考设计）、应用或其他设计建议、网络工具、安全信息和其他资源，不保证其中不含任何瑕疵，且不做任何明示或暗示的担保，包括但不限于对适销性、适合某特定用途或不侵犯任何第三方知识产权的暗示担保。

所述资源可供专业开发人员应用TI 产品进行设计使用。您将对以下行为独自承担全部责任：(1) 针对您的应用选择合适的TI 产品；(2) 设计、验证并测试您的应用；(3) 确保您的应用满足相应标准以及任何其他安全、安保或其他要求。所述资源如有变更，恕不另行通知。TI 对您使用所述资源的授权仅限于开发资源所涉及TI 产品的相关应用。除此之外不得复制或展示所述资源，也不提供其它TI 或任何第三方的知识产权授权许可。如因使用所述资源而产生任何索赔、赔偿、成本、损失及债务等，TI 对此概不负责，并且您须赔偿由此对TI 及其代表造成的损害。

TI 所提供产品均受TI 的销售条款 (<http://www.ti.com.cn/zh-cn/legal/termsofsale.html>) 以及ti.com.cn 上或随附TI 产品提供的其他可适用条款的约束。TI 提供所述资源并不扩展或以其他方式更改TI 针对TI 产品所发布的可适用的担保范围或担保免责声明。

邮寄地址：上海市浦东新区世纪大道 1568 号中建大厦 32 楼，邮政编码：200122

Copyright © 2020 德州仪器半导体技术（上海）有限公司