

## OP07x Precision Operational Amplifiers

### 1 Features

- Low Noise
- No External Components Required
- Replace Chopper Amplifiers at a Lower Cost
- Wide Input-Voltage Range: 0 to  $\pm 14$  V (Typ)
- Wide Supply-Voltage Range:  $\pm 3$  V to  $\pm 18$  V

### 2 Applications

- Wireless Base Station Control Circuits
- Optical Network Control Circuits
- Instrumentation
- Sensors and Controls
- Precision Filters

### 3 Description

These devices offer low offset and long-term stability by means of a low-noise, chopperless, bipolar-input-transistor amplifier circuit. For most applications, external components are not required for offset nulling and frequency compensation. The true differential input, with a wide input-voltage range and outstanding common-mode rejection, provides maximum flexibility and performance in high-noise environments and in noninverting applications. Low bias currents and extremely high input impedances are maintained over the entire temperature range.

#### Device Information(1)

PART NUMBER	PACKAGE (PIN)	BODY SIZE
OP07x	SO (8)	6.20 mm x 5.30 mm
	SOIC (8)	4.90 mm x 3.91 mm
	PDIP (8)	9.81 mm x 6.35 mm

(1) For all available packages, see the orderable addendum at the end of the data sheet.

### 4 Simplified Schematic

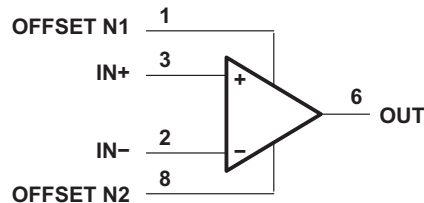

## Table of Contents

<b>1 Features</b> .....	<b>1</b>	9.2 Functional Block Diagram .....	<b>7</b>
<b>2 Applications</b> .....	<b>1</b>	9.3 Feature Description .....	<b>7</b>
<b>3 Description</b> .....	<b>1</b>	9.4 Device Functional Modes .....	<b>7</b>
<b>4 Simplified Schematic</b> .....	<b>1</b>	<b>10 Application and Implementation</b> .....	<b>8</b>
<b>5 Revision History</b> .....	<b>2</b>	10.1 General Application .....	<b>8</b>
<b>6 Pin Functions</b> .....	<b>3</b>	10.2 Typical Application .....	<b>8</b>
<b>7 Specifications</b> .....	<b>4</b>	<b>11 Power Supply Recommendations</b> .....	<b>10</b>
7.1 Absolute Maximum Ratings .....	<b>4</b>	<b>12 Layout</b> .....	<b>11</b>
7.2 Handling Ratings .....	<b>4</b>	12.1 Layout Guidelines .....	<b>11</b>
7.3 Recommended Operating Conditions .....	<b>4</b>	12.2 Layout Example .....	<b>11</b>
7.4 Thermal Information .....	<b>4</b>	<b>13 Device and Documentation Support</b> .....	<b>12</b>
7.5 Electrical Characteristics .....	<b>5</b>	13.1 Related Links .....	<b>12</b>
7.6 Operating Characteristics .....	<b>6</b>	13.2 Trademarks .....	<b>12</b>
<b>8 Typical Characteristics</b> .....	<b>6</b>	13.3 Electrostatic Discharge Caution .....	<b>12</b>
<b>9 Detailed Description</b> .....	<b>7</b>	13.4 Glossary .....	<b>12</b>
9.1 Overview .....	<b>7</b>	<b>14 Mechanical, Packaging, and Orderable Information</b> .....	<b>12</b>

## 5 Revision History

### Changes from Revision F (January 2014) to Revision G

**Page**

- Added *Applications*, *Device Information* table, *Pin Functions* table, *Handling Ratings* table, *Thermal Information* table, *Typical Characteristics*, *Feature Description* section, *Device Functional Modes*, *Application and Implementation* section, *Power Supply Recommendations* section, *Layout* section, *Device and Documentation Support* section, and *Mechanical, Packaging, and Orderable Information* section. .... **1**

### Changes from Revision E (May 2004) to Revision F

**Page**

- Deleted *Ordering Information* table. .... **1**

## 6 Pin Functions

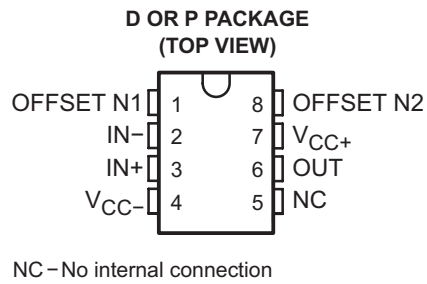

### Pin Functions

PIN		TYPE	DESCRIPTION
NAME	NO.		
IN+	3	I	Noninverting input
IN-	2	I	Inverting input
NC	5	—	Do not connect
OFFSET N1	1	I	External input offset voltage adjustment
OFFSET N2	8	I	External input offset voltage adjustment
OUT	6	O	Output
V <sub>CC+</sub>	7	—	Positive supply
V <sub>CC-</sub>	4	—	Negative supply

## 7 Specifications

### 7.1 Absolute Maximum Ratings

over operating free-air temperature range (unless otherwise noted)<sup>(1)</sup>

		MIN	MAX	UNIT
$V_{CC+}$ <sup>(2)</sup>	Supply voltage	0	22	V
$V_{CC-}$ <sup>(2)</sup>		-22	0	
Differential input voltage <sup>(3)</sup>		±30		V
$V_I$	Input voltage range (either input) <sup>(4)</sup>	±22		V
Duration of output short circuit <sup>(5)</sup>		Unlimited		
$T_J$	Operating virtual-junction temperature	150		°C
Lead temperature 1.6 mm (1/16 in) from case for 10 s		260		°C

- (1) Stresses beyond those listed under *Absolute Maximum Ratings* may cause permanent damage to the device. These are stress ratings only, and functional operation of the device at these or any other conditions beyond those indicated under *Recommended Operating Conditions* is not implied. Exposure to absolute-maximum-rated conditions for extended periods may affect device reliability.
- (2) All voltage values, unless otherwise noted, are with respect to the midpoint between  $V_{CC+}$  and  $V_{CC-}$ .
- (3) Differential voltages are at IN+ with respect to IN-.
- (4) The magnitude of the input voltage must never exceed the magnitude of the supply voltage or 15 V, whichever is less.
- (5) The output may be shorted to ground or to either power supply.

### 7.2 Handling Ratings

PARAMETER	DEFINITION		MIN	MAX	UNIT
$T_{STG}$	Storage temperature range		-65	150	°C
$V_{(ESD)}$	Electrostatic Discharge	Human body model (HBM), per ANSI/ESDA/JEDEC JS-001, all pins <sup>(1)</sup>	0	1000	V
		Charged device model (CDM), per JEDEC specification JESD22-C101, all pins <sup>(2)</sup>	0	1000	

- (1) JEDEC document JEP155 states that 500-V HBM allows safe manufacturing with a standard ESD control process.
- (2) JEDEC document JEP157 states that 250-V CDM allows safe manufacturing with a standard ESD control process.

### 7.3 Recommended Operating Conditions

over operating free-air temperature range (unless otherwise noted)

		MIN	MAX	UNIT
$V_{CC+}$	Supply voltage	3	18	V
$V_{CC-}$		-3	-18	
$V_{IC}$	Common-mode input voltage	-13	13	
$T_A$	Operating free-air temperature	0	70	°C

### 7.4 Thermal Information

THERMAL METRIC <sup>(1)</sup>		D	P	UNIT
$R_{\theta JA}$	Junction-to-ambient thermal resistance	97	85	°C/W

- (1) For more information about traditional and new thermal metrics, see the *IC Package Thermal Metrics* application report ([SPRA953](#)).

## 7.5 Electrical Characteristics

at specified free-air temperature,  $V_{CC\pm} = \pm 15\text{ V}$  (unless otherwise noted)<sup>(1)</sup>

PARAMETER	TEST CONDITIONS	$T_A$ <sup>(2)</sup>	OP07C			OP07D			UNIT	
			MIN	TYP	MAX	MIN	TYP	MAX		
$V_{IO}$	Input offset voltage	$V_O = 0\text{ V}$ $R_S = 50\ \Omega$	25°C	60			150			$\mu\text{V}$
			0°C to 70°C	85			250			
$\alpha_{VIO}$	Temperature coefficient of input offset voltage	$V_O = 0\text{ V}$ $R_S = 50\ \Omega$	0°C to 70°C	0.5			2.5			$\mu\text{V}/^\circ\text{C}$
	Long-term drift of input offset voltage	See		0.4						$\mu\text{V}/\text{mo}$
	Offset adjustment range	$R_S = 20\ \text{k}\Omega$ , See <a href="#">Figure 2</a>	25°C	$\pm 4$						mV
$I_{IO}$	Input offset current		25°C	0.8			6			nA
			0°C to 70°C	1.6			8			
$\alpha_{IIO}$	Temperature coefficient of input offset current		0°C to 70°C	12			50			$\text{pA}/^\circ\text{C}$
$I_{IB}$	Input bias current		25°C	$\pm 1.8$			$\pm 12$			nA
			0°C to 70°C	$\pm 2.2$			$\pm 14$			
$\alpha_{IIB}$	Temperature coefficient of input bias current		0°C to 70°C	18			50			$\text{pA}/^\circ\text{C}$
$V_{ICR}$	Common-mode input voltage range		25°C	$\pm 13$	$\pm 14$	$\pm 13$	$\pm 14$		V	
			0°C to 70°C	$\pm 13$	$\pm 13.5$	$\pm 13$	$\pm 13.5$			
$V_{OM}$	Peak output voltage	$R_L \geq 10\ \text{k}\Omega$ $R_L \geq 2\ \text{k}\Omega$ $R_L \geq 1\ \text{k}\Omega$ $R_L \geq 2\ \text{k}\Omega$	25°C	$\pm 12$	$\pm 13$	$\pm 12$	$\pm 13$		V	
				$\pm 11.5$	$\pm 12.8$	$\pm 11.5$	$\pm 12.8$			
					$\pm 12$		$\pm 12$			
				0°C to 70°C	$\pm 11$	$\pm 12.6$	$\pm 11$	$\pm 12.6$		
$A_{VD}$	Large-signal differential voltage amplification	$V_{CC} = 15\text{ V}$ , $V_O = 1.4\text{ V}$ to $11.4\text{ V}$ , $R_L \geq 500\ \text{k}\Omega$ $V_O = \pm 10$ , $R_L = 2\ \text{k}\Omega$	25°C	100	400	400		V/mV		
			25°C	120	400	120	400			
			0°C to 70°C	100	400	100	400			
$B_1$	Unity-gain bandwidth		25°C	0.4	0.6	0.4	0.6	MHz		
$r_i$	Input resistance		25°C	8	33	7	31	M $\Omega$		
CMRR	Common-mode rejection ratio	$V_{IC} = \pm 13\text{ V}$ , $R_S = 50\ \Omega$	25°C	100	120	94	110	dB		
			0°C to 70°C	97	120	94	106			
$k_{SVS}$	Supply-voltage sensitivity ( $\Delta V_{IO}/\Delta V_{CC}$ )	$V_{CC\pm} = \pm 3\text{ V}$ to $\pm 18\text{ V}$ , $R_S = 50\ \Omega$	25°C	7	32	7	32	$\mu\text{V}/\text{V}$		
			0°C to 70°C	10	51	10	51			
$P_D$	Power dissipation	$V_O = 0$ , No load	25°C	80	150	80	150	mW		
		$V_{CC\pm} = \pm 3\text{ V}$ , $V_O = 0$ , No load		4	8	4	8			

- Because long-term drift cannot be measured on the individual devices prior to shipment, this specification is not intended to be a warranty. It is an engineering estimate of the averaged trend line of drift versus time over extended periods after the first 30 days of operation.
- All characteristics are measured with zero common-mode input voltage, unless otherwise specified.

## 7.6 Operating Characteristics

at specified free-air temperature,  $V_{CC} = 5\text{ V}$  (unless otherwise noted)

PARAMETER	TEST CONDITIONS <sup>(1)</sup>	OP07C	OP07D	UNIT
		TYP	TYP	
$V_n$ Input offset voltage	f = 10 Hz	10.5	10.5	$\text{nV}/\sqrt{\text{Hz}}$
	f = 100 Hz	10.2	10.3	
	f = 1 kHz	9.8	9.8	
$V_{N(PP)}$ Peak-to-peak equivalent input noise voltage	f = 0.1 Hz to 10 Hz	0.38	0.38	$\mu\text{V}$
$I_n$ Equivalent input noise current	f = 10 Hz	0.35	0.35	$\text{nV}/\sqrt{\text{Hz}}$
	f = 100 Hz	0.15	0.15	
	f = 1 kHz	0.13	0.13	
$I_{N(PP)}$ Peak-to-peak equivalent input noise current	f = 0.1 Hz to 10 Hz	15	15	$\mu\text{A}$
SR Slew rate	$R_L \geq 2\text{ k}\Omega$	0.3	0.3	$\text{V}/\mu\text{s}$

(1) All characteristics are measured under open-loop conditions, with zero common-mode input voltage, unless otherwise noted.

## 8 Typical Characteristics

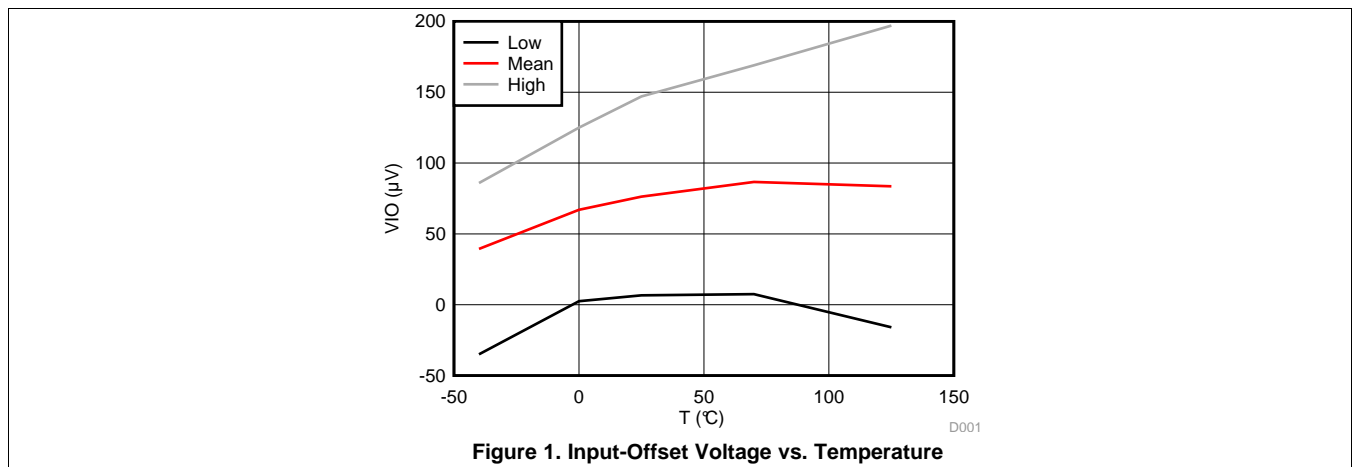

## 9 Detailed Description

### 9.1 Overview

These devices offer low offset and long-term stability by means of a low-noise, chopperless, bipolar-input-transistor amplifier circuit. For most applications, external components are not required for offset nulling and frequency compensation. The true differential input, with a wide input-voltage range and outstanding common-mode rejection, provides maximum flexibility and performance in high-noise environments and in noninverting applications. Low bias currents and extremely high input impedances are maintained over the entire temperature range.

These devices are characterized for operation from 0°C to 70°C.

### 9.2 Functional Block Diagram

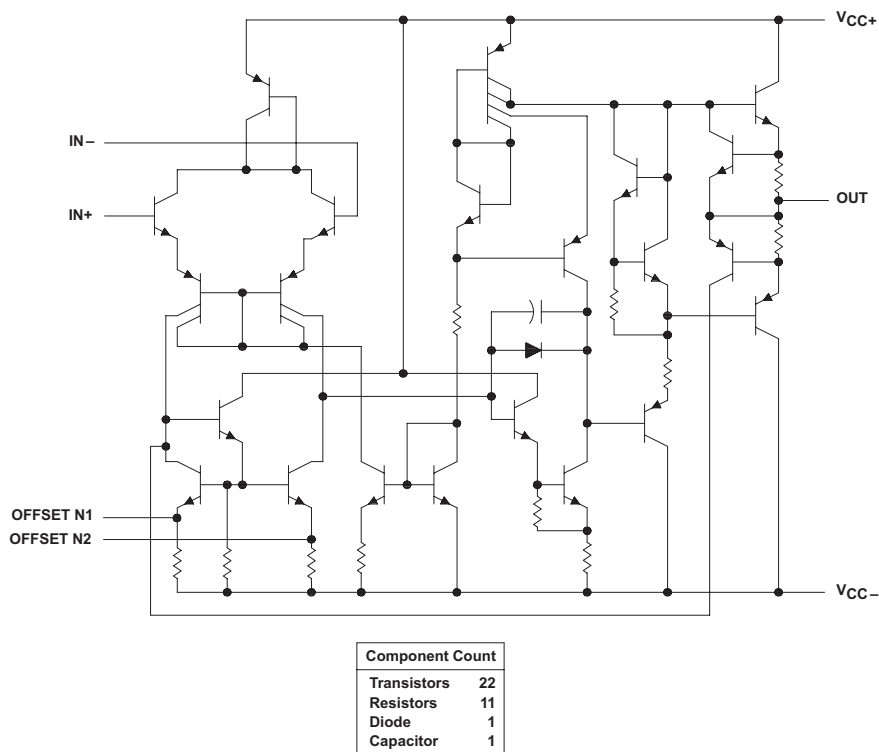

### 9.3 Feature Description

#### 9.3.1 Offset-Voltage Null Capability

The input offset voltage of operational amplifiers (op amps) arises from unavoidable mismatches in the differential input stage of the op-amp circuit caused by mismatched transistor pairs, collector currents, current-gain betas ( $\beta$ ), collector or emitter resistors, et cetera. The input offset pins allow the designer to adjust for these mismatches by external circuitry. See the [Application and Implementation](#) section for more details on design techniques.

#### 9.3.2 Slew Rate

The slew rate is the rate at which an operational amplifier can change its output when there is a change on the input. The OP07 has a 0.3-V/ $\mu$ s slew rate.

### 9.4 Device Functional Modes

The OP07 is powered on when the supply is connected. It can be operated as a single supply operational amplifier or dual supply amplifier depending on the application.

## 10 Application and Implementation

### 10.1 General Application

The input offset voltage of operational amplifiers (op amps) arises from unavoidable mismatches in the differential input stage of the op-amp circuit caused by mismatched transistor pairs, collector currents, current-gain betas ( $\beta$ ), collector or emitter resistors, etc. The input offset pins allow the designer to adjust for these mismatches by external circuitry. These input mismatches can be adjusted by putting resistors or a potentiometer between the inputs as shown in [Figure 2](#). A potentiometer can be used to fine tune the circuit during testing or for applications which require precision offset control. More information about designing using the input-offset pins, see [Nulling Input Offset Voltage of Operational Amplifiers \(SLOA045\)](#).

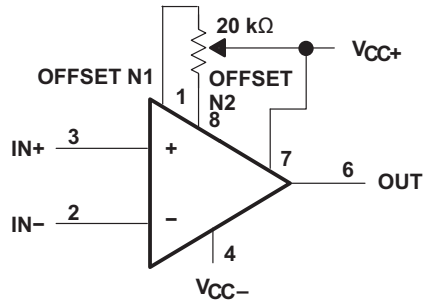

**Figure 2. Input Offset-Voltage Null Circuit**

### 10.2 Typical Application

The voltage follower configuration of the operational amplifier is used for applications where a weak signal is used to drive a relatively high current load. This circuit is also called a buffer amplifier or unity gain amplifier. The inputs of an operational amplifier have a very high resistance which puts a negligible current load on the voltage source. The output resistance of the operational amplifier is almost negligible, so it can provide as much current as necessary to the output load.

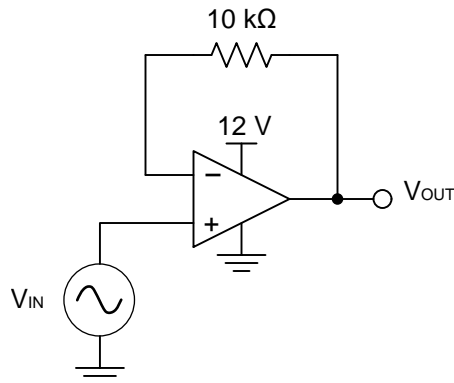

**Figure 3. Voltage Follower Schematic**

**Typical Application (continued)**

**10.2.1 Design Requirements**

- Output range of 2 V to 11 V
- Input range of 2 V to 11 V

**10.2.2 Detailed Design Procedure**

**10.2.2.1 Output Voltage Swing**

The output voltage of an operational amplifier is limited by its internal circuitry to some level below the supply rails. For this amplifier, the output voltage swing is within  $\pm 12$  V, which accommodates the input and output voltage requirements.

**10.2.2.2 Supply and Input Voltage**

For correct operation of the amplifier, neither input must be higher than the recommended positive supply rail voltage or lower than the recommended negative supply rail voltage. The chosen amplifier must be able to operate at the supply voltage that accommodates the inputs. Because the input for this application goes up to 11 V, the supply voltage must be 12 V. Using a negative voltage on the lower rail, rather than ground, allows the amplifier to maintain linearity for inputs below 2 V.

**10.2.3 Application Curves for Output Characteristics**

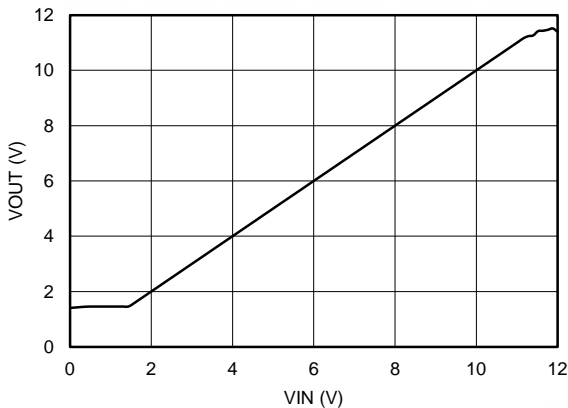

**Figure 4. Output Voltage vs Input Voltage**

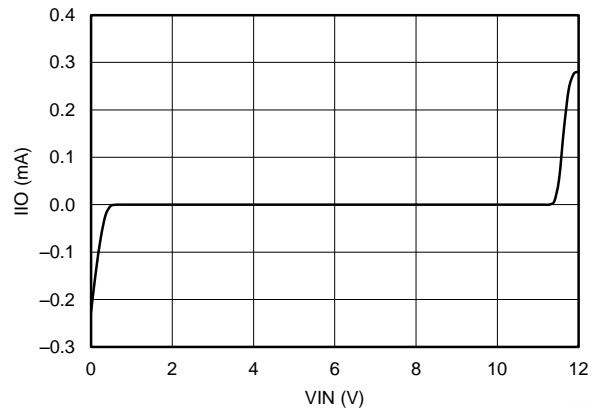

**Figure 5. Current Drawn by the Input of the Voltage Follower ( $I_{IO}$ ) vs the Input Voltage**

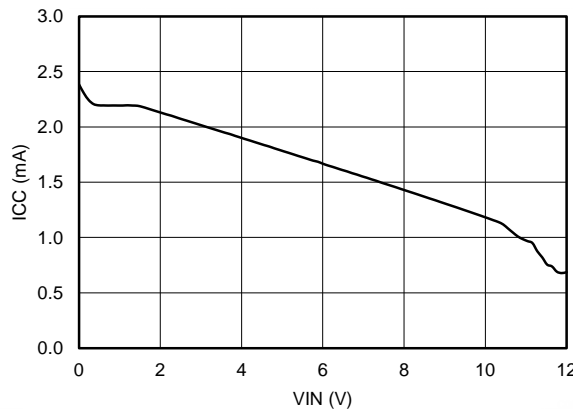

**Figure 6. Current Drawn from Supply ( $I_{CC}$ ) vs the Input Voltage**

## 11 Power Supply Recommendations

The OP07 is specified for operation from  $\pm 3$  to  $\pm 18$  V; many specifications apply from 0°C to 70°C.

### CAUTION

Supply voltages larger than  $\pm 22$  V can permanently damage the device (see the [Absolute Maximum Ratings](#)).

Place 0.1- $\mu$ F bypass capacitors close to the power-supply pins to reduce errors coupling in from noisy or high impedance power supplies. For more detailed information on bypass capacitor placement, refer to the [Layout Guidelines](#).

## 12 Layout

### 12.1 Layout Guidelines

For best operational performance of the device, use good PCB layout practices, including:

- Noise can propagate into analog circuitry through the power pins of the circuit as a whole, as well as the operational amplifier. Bypass capacitors are used to reduce the coupled noise by providing low-impedance power sources local to the analog circuitry.
  - Connect low-ESR, 0.1- $\mu$ F ceramic bypass capacitors between each supply pin and ground, placed as close to the device as possible. A single bypass capacitor from V+ to ground is applicable for single supply applications.
- Separate grounding for analog and digital portions of circuitry is one of the simplest and most-effective methods of noise suppression. On multilayer PCBs, one or more layers are usually devoted to ground planes. A ground plane helps distribute heat and reduces EMI noise pickup. Make sure to physically separate digital and analog grounds, paying attention to the flow of the ground current. For more detailed information, refer to *Circuit Board Layout Techniques*, (SLOA089).
- To reduce parasitic coupling, run the input traces as far away from the supply or output traces as possible. If it is not possible to keep them separate, it is much better to cross the sensitive trace perpendicularly, as opposed to in parallel, with the noisy trace.
- Place the external components as close to the device as possible. Keeping RF and RG close to the inverting input minimizes parasitic capacitance, as shown in *Layout Example*.
- Keep the length of input traces as short as possible. Always remember that the input traces are the most sensitive part of the circuit.
- Consider a driven, low-impedance guard ring around the critical traces. A guard ring can significantly reduce leakage currents from nearby traces that are at different potentials.

### 12.2 Layout Example

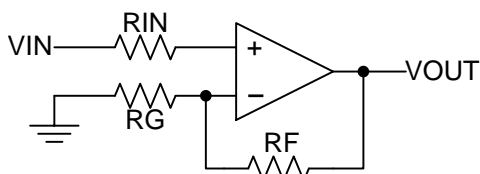

Figure 7. Operational Amplifier Schematic for Noninverting Configuration

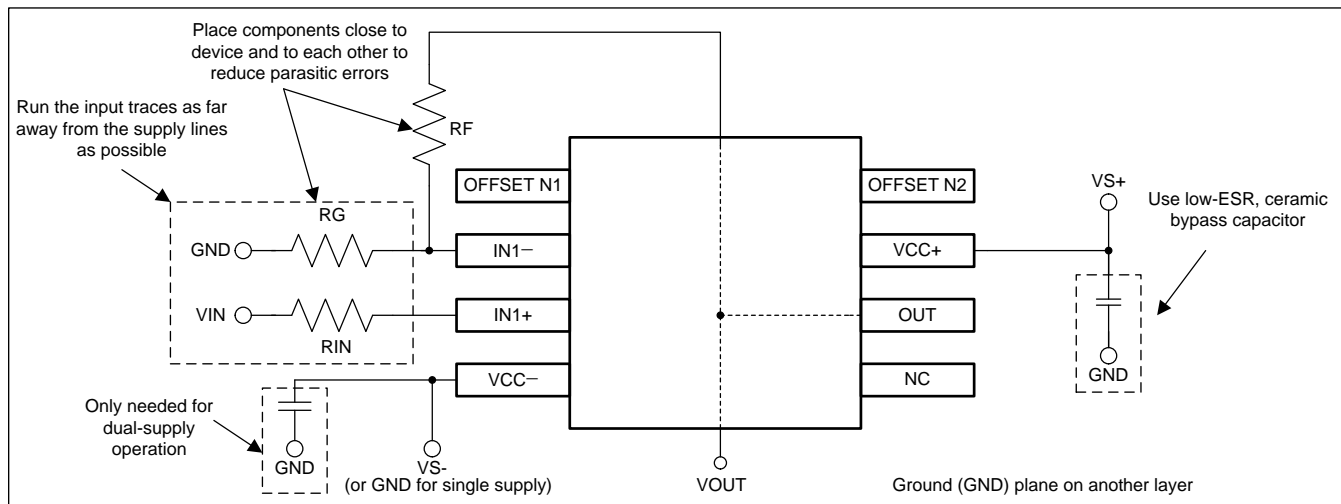

Figure 8. Operational Amplifier Board Layout for Noninverting Configuration

## 13 Device and Documentation Support

### 13.1 Related Links

The table below lists quick access links. Categories include technical documents, support and community resources, tools and software, and quick access to sample or buy.

**Table 1. Related Links**

Parts	Product Folder	Sample & Buy	Technical Documents	Tools & Software	Support & Community
OP07C	<a href="#">Click here</a>	<a href="#">Click here</a>	<a href="#">Click here</a>	<a href="#">Click here</a>	<a href="#">Click here</a>
OP07D	<a href="#">Click here</a>	<a href="#">Click here</a>	<a href="#">Click here</a>	<a href="#">Click here</a>	<a href="#">Click here</a>

### 13.2 Trademarks

All trademarks are the property of their respective owners.

### 13.3 Electrostatic Discharge Caution



This integrated circuit can be damaged by ESD. Texas Instruments recommends that all integrated circuits be handled with appropriate precautions. Failure to observe proper handling and installation procedures can cause damage.

ESD damage can range from subtle performance degradation to complete device failure. Precision integrated circuits may be more susceptible to damage because very small parametric changes could cause the device not to meet its published specifications.

### 13.4 Glossary

[SLYZ022](#) — *TI Glossary*.

This glossary lists and explains terms, acronyms and definitions.

## 14 Mechanical, Packaging, and Orderable Information

The following pages include mechanical packaging and orderable information. This information is the most current data available for the designated devices. This data is subject to change without notice and revision of this document. For browser based versions of this data sheet, refer to the left hand navigation.

**PACKAGING INFORMATION**

Orderable Device	Status (1)	Package Type	Package Drawing	Pins	Package Qty	Eco Plan (2)	Lead finish/ Ball material (6)	MSL Peak Temp (3)	Op Temp (°C)	Device Marking (4/5)	Samples
OP-07DP	ACTIVE	PDIP	P	8	50	RoHS & Green	NIPDAU	N / A for Pkg Type	0 to 70	OP-07DP	<a href="#">Samples</a>
OP-07DPS	ACTIVE	SO	PS	8	80	RoHS & Green	NIPDAU	Level-1-260C-UNLIM	0 to 70	OP-07D	<a href="#">Samples</a>
OP-07DPSR	ACTIVE	SO	PS	8	2000	RoHS & Green	NIPDAU	Level-1-260C-UNLIM	0 to 70	OP-07D	<a href="#">Samples</a>
OP-07DPSRG4	ACTIVE	SO	PS	8	2000	RoHS & Green	NIPDAU	Level-1-260C-UNLIM	0 to 70	OP-07D	<a href="#">Samples</a>
OP07-W	ACTIVE	WAFERSALE	YS	0	3603	TBD	Call TI	Call TI			<a href="#">Samples</a>
OP07CD	ACTIVE	SOIC	D	8	75	RoHS & Green	NIPDAU	Level-1-260C-UNLIM	0 to 70	OP07C	<a href="#">Samples</a>
OP07CDE4	ACTIVE	SOIC	D	8	75	RoHS & Green	NIPDAU	Level-1-260C-UNLIM	0 to 70	OP07C	<a href="#">Samples</a>
OP07CDG4	ACTIVE	SOIC	D	8	75	RoHS & Green	NIPDAU	Level-1-260C-UNLIM	0 to 70	OP07C	<a href="#">Samples</a>
OP07CDR	ACTIVE	SOIC	D	8	2500	RoHS & Green	NIPDAU   SN	Level-1-260C-UNLIM	0 to 70	OP07C	<a href="#">Samples</a>
OP07CDRE4	ACTIVE	SOIC	D	8	2500	RoHS & Green	NIPDAU	Level-1-260C-UNLIM	0 to 70	OP07C	<a href="#">Samples</a>
OP07CDRG4	ACTIVE	SOIC	D	8	2500	RoHS & Green	NIPDAU	Level-1-260C-UNLIM	0 to 70	OP07C	<a href="#">Samples</a>
OP07CP	ACTIVE	PDIP	P	8	50	RoHS & Green	NIPDAU	N / A for Pkg Type	0 to 70	OP07CP	<a href="#">Samples</a>
OP07CPE4	ACTIVE	PDIP	P	8	50	RoHS & Green	NIPDAU	N / A for Pkg Type	0 to 70	OP07CP	<a href="#">Samples</a>
OP07DD	ACTIVE	SOIC	D	8	75	RoHS & Green	NIPDAU	Level-1-260C-UNLIM	0 to 70	OP07D	<a href="#">Samples</a>
OP07DDR	ACTIVE	SOIC	D	8	2500	RoHS & Green	NIPDAU	Level-1-260C-UNLIM	0 to 70	OP07D	<a href="#">Samples</a>
OP07DDRE4	ACTIVE	SOIC	D	8	2500	RoHS & Green	NIPDAU	Level-1-260C-UNLIM	0 to 70	OP07D	<a href="#">Samples</a>
OP07DP	ACTIVE	PDIP	P	8	50	RoHS & Green	NIPDAU	N / A for Pkg Type	0 to 70	OP07DP	<a href="#">Samples</a>
OP07DPE4	ACTIVE	PDIP	P	8	50	RoHS & Green	NIPDAU	N / A for Pkg Type	0 to 70	OP07DP	<a href="#">Samples</a>

(1) The marketing status values are defined as follows:

**ACTIVE:** Product device recommended for new designs.

**LIFEBUY:** TI has announced that the device will be discontinued, and a lifetime-buy period is in effect.

**NRND:** Not recommended for new designs. Device is in production to support existing customers, but TI does not recommend using this part in a new design.

**PREVIEW:** Device has been announced but is not in production. Samples may or may not be available.

**OBSOLETE:** TI has discontinued the production of the device.

<sup>(2)</sup> **RoHS:** TI defines "RoHS" to mean semiconductor products that are compliant with the current EU RoHS requirements for all 10 RoHS substances, including the requirement that RoHS substance do not exceed 0.1% by weight in homogeneous materials. Where designed to be soldered at high temperatures, "RoHS" products are suitable for use in specified lead-free processes. TI may reference these types of products as "Pb-Free".

**RoHS Exempt:** TI defines "RoHS Exempt" to mean products that contain lead but are compliant with EU RoHS pursuant to a specific EU RoHS exemption.

**Green:** TI defines "Green" to mean the content of Chlorine (Cl) and Bromine (Br) based flame retardants meet JS709B low halogen requirements of  $\leq 1000$ ppm threshold. Antimony trioxide based flame retardants must also meet the  $\leq 1000$ ppm threshold requirement.

<sup>(3)</sup> MSL, Peak Temp. - The Moisture Sensitivity Level rating according to the JEDEC industry standard classifications, and peak solder temperature.

<sup>(4)</sup> There may be additional marking, which relates to the logo, the lot trace code information, or the environmental category on the device.

<sup>(5)</sup> Multiple Device Markings will be inside parentheses. Only one Device Marking contained in parentheses and separated by a "~" will appear on a device. If a line is indented then it is a continuation of the previous line and the two combined represent the entire Device Marking for that device.

<sup>(6)</sup> Lead finish/Ball material - Orderable Devices may have multiple material finish options. Finish options are separated by a vertical ruled line. Lead finish/Ball material values may wrap to two lines if the finish value exceeds the maximum column width.

**Important Information and Disclaimer:** The information provided on this page represents TI's knowledge and belief as of the date that it is provided. TI bases its knowledge and belief on information provided by third parties, and makes no representation or warranty as to the accuracy of such information. Efforts are underway to better integrate information from third parties. TI has taken and continues to take reasonable steps to provide representative and accurate information but may not have conducted destructive testing or chemical analysis on incoming materials and chemicals. TI and TI suppliers consider certain information to be proprietary, and thus CAS numbers and other limited information may not be available for release.

In no event shall TI's liability arising out of such information exceed the total purchase price of the TI part(s) at issue in this document sold by TI to Customer on an annual basis.

**TAPE AND REEL INFORMATION**

**QUADRANT ASSIGNMENTS FOR PIN 1 ORIENTATION IN TAPE**



\*All dimensions are nominal

Device	Package Type	Package Drawing	Pins	SPQ	Reel Diameter (mm)	Reel Width W1 (mm)	A0 (mm)	B0 (mm)	K0 (mm)	P1 (mm)	W (mm)	Pin1 Quadrant
OP-07DPSR	SO	PS	8	2000	330.0	16.4	8.35	6.6	2.4	12.0	16.0	Q1
OP07CDR	SOIC	D	8	2500	330.0	12.4	6.4	5.2	2.1	8.0	12.0	Q1
OP07CDRG4	SOIC	D	8	2500	330.0	12.4	6.4	5.2	2.1	8.0	12.0	Q1
OP07DDR	SOIC	D	8	2500	330.0	12.4	6.4	5.2	2.1	8.0	12.0	Q1

**TAPE AND REEL BOX DIMENSIONS**

\*All dimensions are nominal

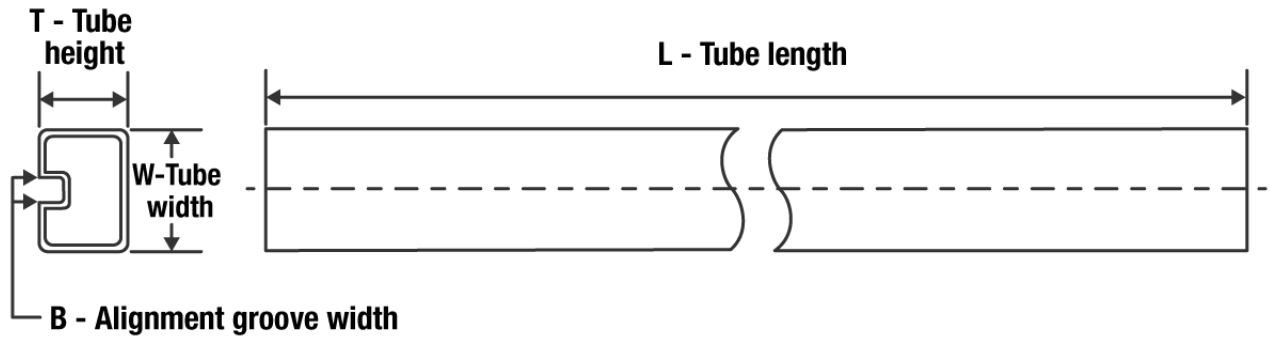
Device	Package Type	Package Drawing	Pins	SPQ	Length (mm)	Width (mm)	Height (mm)
OP-07DPSR	SO	PS	8	2000	853.0	449.0	35.0
OP07CDR	SOIC	D	8	2500	340.5	336.1	25.0
OP07CDRG4	SOIC	D	8	2500	340.5	336.1	25.0
OP07DDR	SOIC	D	8	2500	340.5	336.1	25.0

**TUBE**

\*All dimensions are nominal

Device	Package Name	Package Type	Pins	SPQ	L (mm)	W (mm)	T (μm)	B (mm)
OP-07DP	P	PDIP	8	50	506	13.97	11230	4.32
OP-07DPS	PS	SOP	8	80	530	10.5	4000	4.1
OP07CD	D	SOIC	8	75	507	8	3940	4.32
OP07CDE4	D	SOIC	8	75	507	8	3940	4.32
OP07CDG4	D	SOIC	8	75	507	8	3940	4.32
OP07CP	P	PDIP	8	50	506	13.97	11230	4.32
OP07CPE4	P	PDIP	8	50	506	13.97	11230	4.32
OP07DD	D	SOIC	8	75	507	8	3940	4.32
OP07DP	P	PDIP	8	50	506	13.97	11230	4.32
OP07DPE4	P	PDIP	8	50	506	13.97	11230	4.32



D0008A

# PACKAGE OUTLINE

SOIC - 1.75 mm max height

SMALL OUTLINE INTEGRATED CIRCUIT



4214825/C 02/2019

## NOTES:

- Linear dimensions are in inches [millimeters]. Dimensions in parenthesis are for reference only. Controlling dimensions are in inches. Dimensioning and tolerancing per ASME Y14.5M.
- This drawing is subject to change without notice.
- This dimension does not include mold flash, protrusions, or gate burrs. Mold flash, protrusions, or gate burrs shall not exceed .006 [0.15] per side.
- This dimension does not include interlead flash.
- Reference JEDEC registration MS-012, variation AA.

# EXAMPLE BOARD LAYOUT

D0008A

SOIC - 1.75 mm max height

SMALL OUTLINE INTEGRATED CIRCUIT



LAND PATTERN EXAMPLE  
 EXPOSED METAL SHOWN  
 SCALE:8X



SOLDER MASK DETAILS

4214825/C 02/2019

NOTES: (continued)

- 6. Publication IPC-7351 may have alternate designs.
- 7. Solder mask tolerances between and around signal pads can vary based on board fabrication site.

# EXAMPLE STENCIL DESIGN

D0008A

SOIC - 1.75 mm max height

SMALL OUTLINE INTEGRATED CIRCUIT



SOLDER PASTE EXAMPLE  
BASED ON .005 INCH [0.125 MM] THICK STENCIL  
SCALE:8X

4214825/C 02/2019

NOTES: (continued)

8. Laser cutting apertures with trapezoidal walls and rounded corners may offer better paste release. IPC-7525 may have alternate design recommendations.
9. Board assembly site may have different recommendations for stencil design.

## MECHANICAL DATA

PS (R-PDSO-G8)

PLASTIC SMALL-OUTLINE PACKAGE

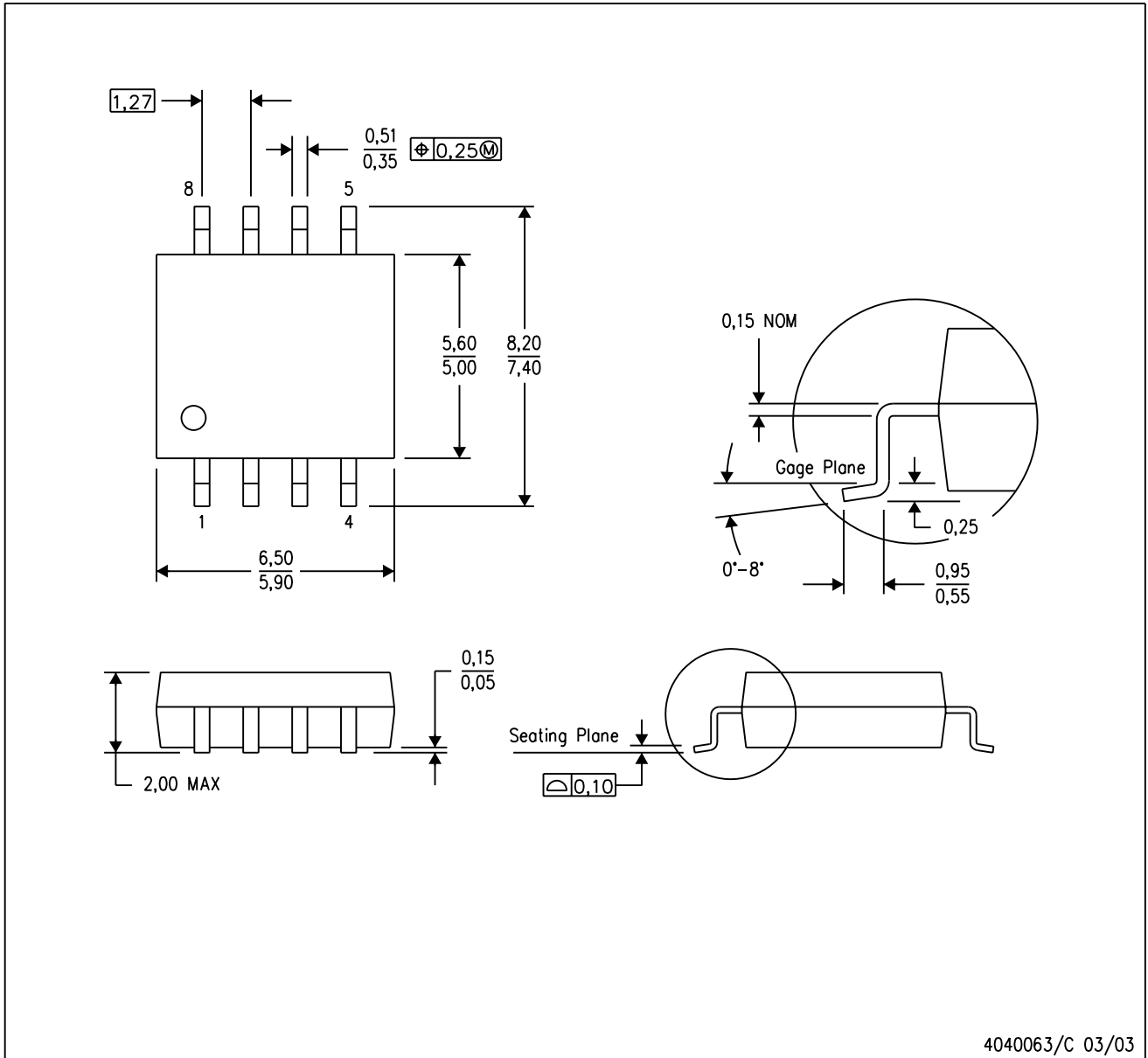

- NOTES:
- A. All linear dimensions are in millimeters.
  - B. This drawing is subject to change without notice.
  - C. Body dimensions do not include mold flash or protrusion, not to exceed 0,15.

P (R-PDIP-T8)

PLASTIC DUAL-IN-LINE PACKAGE

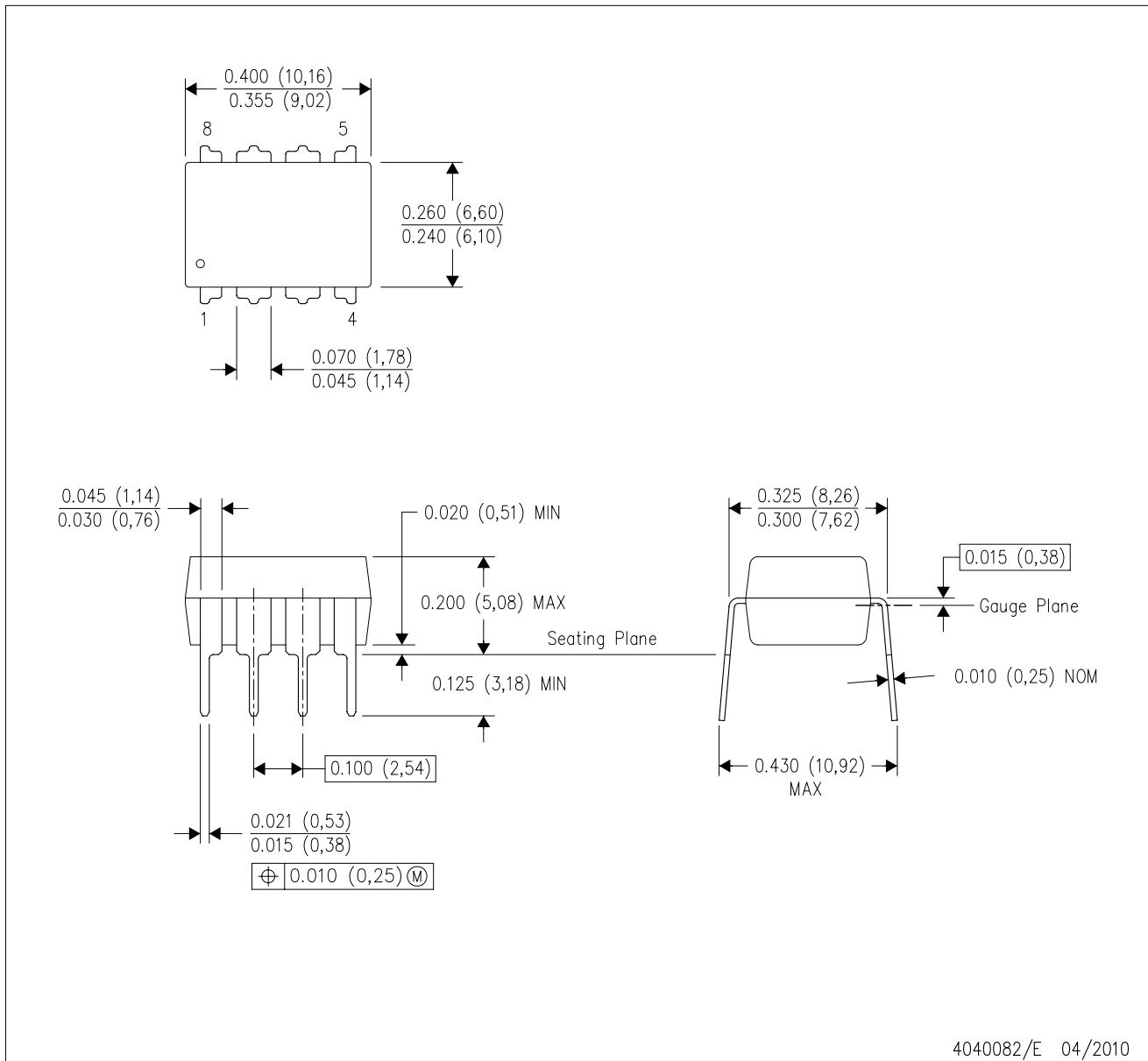

- NOTES:
- A. All linear dimensions are in inches (millimeters).
  - B. This drawing is subject to change without notice.
  - C. Falls within JEDEC MS-001 variation BA.

## IMPORTANT NOTICE AND DISCLAIMER

TI PROVIDES TECHNICAL AND RELIABILITY DATA (INCLUDING DATA SHEETS), DESIGN RESOURCES (INCLUDING REFERENCE DESIGNS), APPLICATION OR OTHER DESIGN ADVICE, WEB TOOLS, SAFETY INFORMATION, AND OTHER RESOURCES "AS IS" AND WITH ALL FAULTS, AND DISCLAIMS ALL WARRANTIES, EXPRESS AND IMPLIED, INCLUDING WITHOUT LIMITATION ANY IMPLIED WARRANTIES OF MERCHANTABILITY, FITNESS FOR A PARTICULAR PURPOSE OR NON-INFRINGEMENT OF THIRD PARTY INTELLECTUAL PROPERTY RIGHTS.

These resources are intended for skilled developers designing with TI products. You are solely responsible for (1) selecting the appropriate TI products for your application, (2) designing, validating and testing your application, and (3) ensuring your application meets applicable standards, and any other safety, security, regulatory or other requirements.

These resources are subject to change without notice. TI grants you permission to use these resources only for development of an application that uses the TI products described in the resource. Other reproduction and display of these resources is prohibited. No license is granted to any other TI intellectual property right or to any third party intellectual property right. TI disclaims responsibility for, and you will fully indemnify TI and its representatives against, any claims, damages, costs, losses, and liabilities arising out of your use of these resources.

TI's products are provided subject to [TI's Terms of Sale](#) or other applicable terms available either on [ti.com](http://ti.com) or provided in conjunction with such TI products. TI's provision of these resources does not expand or otherwise alter TI's applicable warranties or warranty disclaimers for TI products.

TI objects to and rejects any additional or different terms you may have proposed.

Mailing Address: Texas Instruments, Post Office Box 655303, Dallas, Texas 75265  
Copyright © 2022, Texas Instruments Incorporated