

ISO723xx High-Speed, Triple-Channel Digital Isolators

1 Features

- 25 and 150-Mbps Signaling Rate Options
 - Low Channel-to-Channel Output Skew; 1 ns Maximum
 - Low Pulse-Width Distortion (PWD); 2 ns Maximum
 - Low Jitter Content; 1 ns Typical at 150 Mbps
- Typical 25-Year Life at Rated Working Voltage (See Application Note [SLLA197](#) and [Figure 19](#))
- 4-kV ESD Protection
- Operate With 3.3-V or 5-V Supplies
- 3.3-V and 5-V Level Translation
- High Electromagnetic Immunity (See Application Note [SLLA181](#))
- –40°C to 125°C Operating Range
- Safety and Regulatory Approvals
 - 4000- V_{PK} Isolation per DIN V VDE V 0884-10 and DIN EN 61010-1
 - 2500 V_{RMS} Isolation for 1 minute per UL 1577
 - CSA Component Acceptance Notice 5A and IEC 60950-1 End Equipment Standard

2 Applications

- Industrial Fieldbus
- Computer Peripheral Interface
- Servo Control Interface
- Data Acquisition

3 Description

The ISO7230 and ISO7231 are triple-channel digital isolators each with multiple channel configurations and output enable functions. These devices have logic input and output buffers separated by TI's silicon dioxide (SiO_2) isolation barrier. Used in conjunction with isolated power supplies, these devices block high voltage, isolate grounds, and prevent noise currents on a data bus or other circuits from entering the local ground and interfering with or damaging sensitive circuitry.

Device Information⁽¹⁾

PART NUMBER	PACKAGE	BODY SIZE (NOM)
ISO7230C ISO7230M ISO7231C ISO7231M	SOIC (16)	10.30 mm x 7.50 mm

(1) For all available packages, see the orderable addendum at the end of the datasheet.

Simplified Schematic

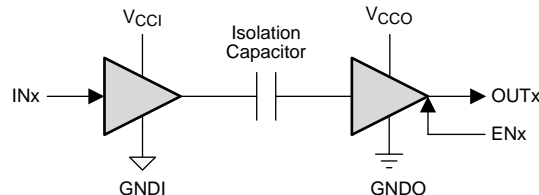

(1) V_{CCI} and $GNDI$ are supply and ground connections respectively for the input channels.

(2) V_{CCO} and $GNDO$ are supply and ground connections respectively for the output channels.



Table of Contents

1 Features	1	V.....	12
2 Applications	1	7.14 Typical Characteristics	13
3 Description	1	8 Parameter Measurement Information	15
4 Revision History	2	9 Detailed Description	17
5 Device Comparison Table	4	9.1 Overview	17
6 Pin Configuration and Functions	4	9.2 Functional Block Diagram	17
7 Specifications	5	9.3 Feature Description.....	18
7.1 Absolute Maximum Ratings	5	9.4 Device Functional Modes.....	19
7.2 ESD Ratings.....	5	10 Application and Implementation	21
7.3 Recommended Operating Conditions.....	5	10.1 Application Information.....	21
7.4 Thermal Information	6	10.2 Typical Application	21
7.5 Electrical Characteristics: V_{CC1} and V_{CC2} at 5-V	6	11 Power Supply Recommendations	24
7.6 Electrical Characteristics: V_{CC1} at 5-V, V_{CC2} at 3.3-V.....	7	12 Layout	24
7.7 Electrical Characteristics: V_{CC1} at 3.3-V, V_{CC2} at 5-V	8	12.1 Layout Guidelines	24
7.8 Electrical Characteristics: V_{CC1} and V_{CC2} at 3.3 V ...	9	12.2 Layout Example	24
7.9 Power Dissipation Characteristics	9	13 Device and Documentation Support	25
7.10 Switching Characteristics: V_{CC1} and V_{CC2} at 5-V .	10	13.1 Related Documentation.....	25
7.11 Switching Characteristics: V_{CC1} at 5-V, V_{CC2} at 3.3-V	11	13.2 Related Links	25
7.12 Switching Characteristics: V_{CC1} at 3.3-V and V_{CC2} at 5-V	12	13.3 Community Resources.....	25
7.13 Switching Characteristics: V_{CC1} and V_{CC2} at 3.3-		13.4 Trademarks	25
		13.5 Electrostatic Discharge Caution.....	25
		13.6 Glossary	25
		14 Mechanical, Packaging, and Orderable Information	25

4 Revision History

NOTE: Page numbers for previous revisions may differ from page numbers in the current version.

Changes from Revision J (May 2015) to Revision K	Page
• Added Note 1 to L(I01) and changed the MIN value From: 8.34 To 8 mm in the <i>Package Insulation and Safety-Related Specifications</i> table	18
• Added Note 1 to L(I02) and changed the MIN value From: 8.1 To 8 mm in the <i>Package Insulation and Safety-Related Specifications</i> table	18
• Deleted Note 1 From the <i>Regulatory Information</i> table	18
• Changed The ground symbols on the Enable circuit in Figure 15	20

Changes from Revision I (January 2011) to Revision J	Page
• Added <i>Pin Configuration and Functions</i> section, <i>ESD Ratings</i> table, <i>Feature Description</i> section, <i>Device Functional Modes</i> , <i>Application and Implementation</i> section, <i>Power Supply Recommendations</i> section, <i>Layout</i> section, <i>Device and Documentation Support</i> section, and <i>Mechanical, Packaging, and Orderable Information</i> section	1
• Updated Thermal Information	6
• Updated Regulatory Information.....	18

Changes from Revision H (December 2009) to Revision I	Page
• Changed I_{OH} Min value to -4 and deleted the Max value, in the <i>Recommended Operating Conditions</i> Table.....	5
• Changed I_{OL} Max value to 4 and deleted the Min value, in the <i>Recommended Operating Conditions</i> Table	5
• Changed Figure 8 , Figure 10 , Figure 11 , and Figure 12	15
• Changed File Number: 1698195 To: 220991	18

Changes from Revision G (September 2009) to Revision H **Page**

- Changed The Input circuit in [Figure 15](#) 20
-

Changes from Revision F (December 2008) to Revision G **Page**

- Added IEC 60950-1 and CSA Approved to the [Features](#) list 1
-

Changes from Revision E (June 2008) to Revision F **Page**

- Deleted device numbers ISO7230A and ISO7231A from the data sheet 1
 - Added $t_{sk(pp)}$ footnote..... 10
 - Added $t_{sk(o)}$ footnote..... 10
 - Added $t_{sk(pp)}$ footnote..... 12
 - Added $t_{sk(o)}$ footnote..... 12
 - Changed the [Package Insulation and Safety-Related Specifications](#) table, line 1, $L_{(IO1)}$ MIN from 7.7 to 8.34 18
-

Changes from Revision D (May 2008) to Revision E **Page**

- Added Note: For the 5-V operation, VCC1 or VCC2 is specified from 4.5 V to 5.5 V. For the 3-V operation, VCC1 or VCC2 is specified from 3.15 V to 3.6 V..... 6
 - Added Note: For the 5-V operation, VCC1 or VCC2 is specified from 4.5 V to 5.5 V. For the 3-V operation, VCC1 or VCC2 is specified from 3.15 V to 3.6 V..... 7
 - Added Note: For the 5-V operation, VCC1 or VCC2 is specified from 4.5 V to 5.5 V. For the 3-V operation, VCC1 or VCC2 is specified from 3.15 V to 3.6 V..... 8
 - Added Note: For the 5-V operation, VCC1 or VCC2 is specified from 4.5 V to 5.5 V. For the 3-V operation, VCC1 or VCC2 is specified from 3.15 V to 3.6 V..... 9
-

Changes from Revision C (April 2008) to Revision D **Page**

- Changed Features bullet 4000- V_{peak} Isolation to the [Features](#) list 1
 - Added $t_{sk(pp)}$ Part-to-part skew 10
 - Added $t_{sk(pp)}$ Part-to-part skew 11
 - Added $t_{sk(pp)}$ Part-to-part skew 12
 - Added $t_{sk(pp)}$ Part-to-part skew 12
-

Changes from Revision B (April 2008) to Revision C **Page**

- Deleted Min = 4.5 V and max = 5.5 V for Supply Voltage of the [Recommended Operating Conditions](#) Table 5
 - Changed Supply Voltage of the [Recommended Operating Conditions](#) Table From: 3.6 To: 5.5 5
-

Changes from Revision A (December 2007) to Revision B **Page**

- Changed Supply Voltage of the ROC Table From: 3.45 To: 3.6 5
-

Changes from Original (September 2007) to Revision A **Page**

- Deleted Product Preview note 4
 - Changed TBD to actual values..... 6
 - Changed $V_{CC} - 0.4$ To: $V_{CC} - 0.8$ 6
-

ISO7230C, ISO7230M, ISO7231C, ISO7231M

SLLS867K – SEPTEMBER 2007 – REVISED OCTOBER 2015

www.ti.com

• Changed C_1 - Typical value from 1 To: 2.....	6
• Changed C_1 - Typical value from 1 To: 2.....	7
• Changed C_1 - Typical value from 1 To: 2.....	8
• Changed C_1 - Typical value from 1 To: 2.....	9
• Changed Propagation delay max From: 22 To: 23	10
• Changed Propagation delay max From: 46 To: 50	11
• Changed Propagation delay max From: 28 To: 29	11
• Changed Propagation delay max From: 26 To: 30	12
• Changed Propagation delay max From: 32 To: 34	12
• Changed C_{10} - Typical value from 1 To: 2.....	18

5 Device Comparison Table

PRODUCT	SIGNALING RATE	INPUT THRESHOLD	CHANNEL CONFIGURATION	ISOLATION RATING
ISO7230C	25 Mbps	~1.5 V (TTL) (CMOS compatible)	3/0	4000 V _{PK} , 2500 V _{RMS}
ISO7230M	150 Mbps	V _{CC} /2 (CMOS)		
ISO7231C	25 Mbps	~1.5 V (TTL) (CMOS compatible)	2/1	
ISO7231M	150 Mbps	V _{CC} /2 (CMOS)		

6 Pin Configuration and Functions

DW Package
16-Pin SOIC
Top View

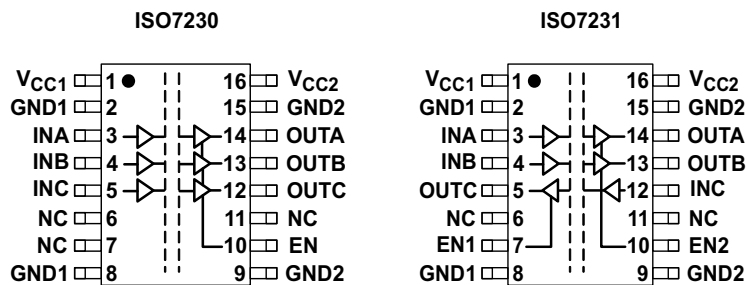

Pin Functions

NAME	PIN		TYPE	DESCRIPTION
	ISO7230	ISO7231		
EN	10	–	I	Enable, channel A, B, and C
EN1	–	7	I	Enable, channel C
EN2	–	10	I	Enable, channel A and B
GND1	2, 8	2, 8	–	Ground connection for V _{CC1}
GND2	9, 15	9, 15	–	Ground connection for V _{CC2}
INA	3	3	I	Input, channel A
INB	4	4	I	Input, channel B
INC	5	12	I	Input, channel C
NC	6, 7, 11	6, 11	–	Not connected
OUTA	14	14	O	Output, channel A
OUTB	13	13	O	Output, channel B
OUTC	12	5	O	Output, channel C
V _{CC1}	1	1	–	Power supply, V _{CC1}
V _{CC2}	16	16	–	Power supply, V _{CC2}

7 Specifications

7.1 Absolute Maximum Ratings⁽¹⁾

		MIN	MAX	UNIT
V _{CC}	Supply voltage ⁽²⁾ , V _{CC1} , V _{CC2}	-0.5	6	V
V _I	Voltage at INx, OUTx, ENx	-0.5	V _{CC} + 0.5 ⁽³⁾	V
I _O	Output current	-15	15	mA
T _J	Maximum junction temperature		170	°C
T _{stg}	Storage temperature	-65	150	°C

(1) Stresses beyond those listed under *absolute maximum ratings* may cause permanent damage to the device. These are stress ratings only and functional operation of the device at these or any other conditions beyond those indicated under *Recommended Operating Conditions* is not implied. Exposure to absolute-maximum-rated conditions for extended periods may affect device reliability.

(2) All voltage values are with respect to network ground terminal and are peak voltage values.

(3) Maximum voltage must not exceed 6 V.

7.2 ESD Ratings

		VALUE	UNIT	
V _(ESD)	Electrostatic discharge	Human body model (HBM), per ANSI/ESDA/JEDEC JS-001 ⁽¹⁾	±4000	V
		Charged-device model (CDM), per JEDEC specification JESD22-C101 ⁽²⁾	±1000	
		Machine model (MM), ANSI/ESDS5.2-1996	±200	

(1) JEDEC document JEP155 states that 500-V HBM allows safe manufacturing with a standard ESD control process.

(2) JEDEC document JEP157 states that 250-V CDM allows safe manufacturing with a standard ESD control process.

7.3 Recommended Operating Conditions

		MIN	NOM	MAX	UNIT	
V _{CC1} , V _{CC2}	Supply voltage - 3.3-V Operation	3.15		5.5	V	
	Supply voltage - 5-V Operation					
I _{OH}	High-level output current	-4			mA	
I _{OL}	Low-level output current			4	mA	
t _{ui}	Input pulse width	ISO723xC	40		ns	
		ISO723xM	6.67	5		
1/t _{ui}	Signaling rate	ISO723xC	0	30 ⁽¹⁾	25	Mbps
		ISO723xM	0	200 ⁽¹⁾	150	
V _{IH}	High-level input voltage (IN)	0.7 V _{CC}		V _{CC}	V	
V _{IL}	Low-level input voltage (IN)					0
V _{IH}	High-level input voltage (IN) (EN on all devices)	ISO723xC		5.5	V	
V _{IL}	Low-level input voltage (IN) (EN on all devices)					2
T _A	Ambient temperature	-40	25	125	°C	
T _J	Junction temperature			150	°C	
H	External magnetic field-strength immunity per IEC 61000-4-8 and IEC 61000-4-9			1000	A/m	

(1) Typical signalling rate under ideal conditions at 25°C.

7.4 Thermal Information

THERMAL METRIC ⁽¹⁾		ISO7230C, ISO7230M ISO7231C, ISO7231M	UNIT
		DW (SOIC)	
		16 PINS	
R _{θJA}	Junction-to-ambient thermal resistance	168	°C/W
		77.3	°C/W
R _{θJC(top)}	Junction-to-case (top) thermal resistance	39.5	°C/W
R _{θJB}	Junction-to-board thermal resistance	41.9	°C/W
Ψ _{JT}	Junction-to-top characterization parameter	13.5	°C/W
Ψ _{JB}	Junction-to-board characterization parameter	41.9	°C/W
R _{θJC(bot)}	Junction-to-case (bottom) thermal resistance	n/a	°C/W

(1) For more information about traditional and new thermal metrics, see the *Semiconductor and IC Package Thermal Metrics* application report, [SPRA953](#).

7.5 Electrical Characteristics: V_{CC1} and V_{CC2} at 5-V⁽¹⁾

over recommended operating conditions (unless otherwise noted)

PARAMETER		TEST CONDITIONS		MIN	TYP	MAX	UNIT
SUPPLY CURRENT							
I _{CC1}	ISO7230C/M	Quiescent	V _I = V _{CC1} or 0 V, all channels, no load, EN at 3 V	1	3		mA
		25 Mbps		7	9.5		
	ISO7231C/M	Quiescent	V _I = V _{CC1} or 0 V, all channels, no load, EN1 at 3 V, EN2 at 3 V	6.5	11		mA
		25 Mbps		11	17		
I _{CC2}	ISO7230C/M	Quiescent	V _I = V _{CC1} or 0 V, all channels, no load, EN at 3 V	15	22		mA
		25 Mbps		17	24		
	ISO7231C/M	Quiescent	V _I = V _{CC1} or 0 V, all channels, no load, EN1 at 3 V, EN2 at 3 V	13	20		mA
		25 Mbps		17.5	27		
ELECTRICAL CHARACTERISTICS							
I _{OFF}	Sleep mode output current	ENx at 0 V, single channel		0			μA
V _{OH}	High-level output voltage	I _{OH} = -4 mA, See Figure 8		V _{CC0} - 0.8			V
		I _{OH} = -20 μA, See Figure 8		V _{CC0} - 0.1			
V _{OL}	Low-level output voltage	I _{OL} = 4 mA, See Figure 8				0.4	V
		I _{OL} = 20 μA, See Figure 8				0.1	
V _{I(HYS)}	Input voltage hysteresis			150			mV
I _{IH}	High-level input current	INx at V _{CC1}				10	μA
I _{IL}	Low-level input current	INx at 0 V		-10			
C _I	Input capacitance to ground	INx at V _{CC1} , V _I = 0.4 sin(4E6πt)		2			pF
CMTI	Common-mode transient immunity	V _I = V _{CC1} or 0 V, See Figure 11		25	50		kV/μs

(1) For the 5-V operation, V_{CC1} or V_{CC2} is specified from 4.5 V to 5.5 V.
For the 3.3-V operation, V_{CC1} or V_{CC2} is specified from 3.15 V to 3.6 V.

7.6 Electrical Characteristics: V_{CC1} at 5-V, V_{CC2} at 3.3-V⁽¹⁾

over recommended operating conditions (unless otherwise noted)

PARAMETER		TEST CONDITIONS		MIN	TYP	MAX	UNIT
SUPPLY CURRENT							
I_{CC1}	ISO7230C/M	Quiescent	$V_I = V_{CC1}$ or 0 V, all channels, no load, EN at 3 V	1		3	mA
		25 Mbps		7		9.5	
	ISO7231C/M	Quiescent	$V_I = V_{CC1}$ or 0 V, all channels, no load, EN1 at 3 V, EN2 at 3 V	6.5		11	mA
		25 Mbps		11		17	
I_{CC2}	ISO7230C/M	Quiescent	$V_I = V_{CC1}$ or 0 V, all channels, no load, EN at 3 V	9		15	mA
		25 Mbps		10		17	
	ISO7231C/M	Quiescent	$V_I = V_{CC1}$ or 0 V, all channels, no load, EN1 at 3 V, EN2 at 3 V	8		12	mA
		25 Mbps		10.5		16	
ELECTRICAL CHARACTERISTICS							
I_{OFF}	Sleep mode output current	ENx at 0 V, Single channel		0			μ A
V_{OH}	High-level output voltage	$I_{OH} = -4$ mA, See Figure 8	ISO7230	$V_{CC0} - 0.4$			V
			ISO7231 (5-V side)	$V_{CC0} - 0.8$			
		$I_{OH} = -20$ μ A, See Figure 8	$V_{CC0} - 0.1$				
V_{OL}	Low-level output voltage	$I_{OL} = 4$ mA, See Figure 8		0.4			V
		$I_{OL} = 20$ μ A, See Figure 8		0.1			
$V_{I(HYS)}$	Input voltage hysteresis			150			mV
I_{IH}	High-level input current	INx at V_{CC1}				10	μ A
I_{IL}	Low-level input current	INx at 0 V		-10			
C_I	Input capacitance to ground	INx at V_{CC1} , $V_I = 0.4 \sin(4E6\pi t)$		2			pF
CMTI	Common-mode transient immunity	$V_I = V_{CC1}$ or 0 V, See Figure 11		25	50		kV/ μ s

- (1) For the 5-V operation, V_{CC1} or V_{CC2} is specified from 4.5 V to 5.5 V.
 For the 3.3-V operation, V_{CC1} or V_{CC2} is specified from 3.15 V to 3.6 V.

7.7 Electrical Characteristics: V_{CC1} at 3.3-V, V_{CC2} at 5-V⁽¹⁾

over recommended operating conditions (unless otherwise noted)

PARAMETER		TEST CONDITIONS		MIN	TYP	MAX	UNIT
SUPPLY CURRENT							
I_{CC1}	ISO7230C/M	Quiescent	$V_I = V_{CC1}$ or 0 V, all channels, no load, EN at 3 V	0.5		1	mA
		25 Mbps		3		5	
	ISO7231C/M	Quiescent	$V_I = V_{CC1}$ or 0 V, all channels, no load, EN1 at 3 V, EN2 at 3 V	4.5		7	mA
		25 Mbps		6.5		11	
I_{CC2}	ISO7230C/M	Quiescent	$V_I = V_{CC1}$ or 0 V, all channels, no load, EN at 3 V	15		22	mA
		25 Mbps		17		24	
	ISO7231C/M	Quiescent	$V_I = V_{CC1}$ or 0 V, all channels, no load, EN1 at 3 V, EN2 at 3 V	13		20	mA
		25 Mbps		17.5		27	
ELECTRICAL CHARACTERISTICS							
I_{OFF}	Sleep mode output current	ENx at 0 V, Single channel		0			μ A
V_{OH}	High-level output voltage	$I_{OH} = -4$ mA, See Figure 8	ISO7230	$V_{CC0} - 0.4$			V
			ISO7231 (5-V side)	$V_{CC0} - 0.8$			
		$I_{OH} = -20$ μ A, See Figure 8	$V_{CC0} - 0.1$				
V_{OL}	Low-level output voltage	$I_{OL} = 4$ mA, See Figure 8		0.4			V
		$I_{OL} = 20$ μ A, See Figure 8		0.1			
$V_{I(HYS)}$	Input voltage hysteresis			150			mV
I_{IH}	High-level input current	INx at V_{CC1}				10	μ A
I_{IL}	Low-level input current	INx at 0 V		-10			
C_I	Input capacitance to ground	INx at V_{CC1} , $V_I = 0.4 \sin(4E6\pi t)$		2			pF
CMTI	Common-mode transient immunity	$V_I = V_{CC1}$ or 0 V, See Figure 11		25	50		kV/ μ s

- (1) For the 5-V operation, V_{CC1} or V_{CC2} is specified from 4.5 V to 5.5 V.
For the 3.3-V operation, V_{CC1} or V_{CC2} is specified from 3.15 V to 3.6 V.

7.8 Electrical Characteristics: V_{CC1} and V_{CC2} at 3.3 V⁽¹⁾

over recommended operating conditions (unless otherwise noted)

PARAMETER		TEST CONDITIONS		MIN	TYP	MAX	UNIT
SUPPLY CURRENT							
I_{CC1}	ISO7230C/M	Quiescent	$V_I = V_{CC1}$ or 0 V, all channels, no load, EN at 3 V		0.5	1	mA
		25 Mbps			3	5	
	ISO7231C/M	Quiescent	$V_I = V_{CC1}$ or 0 V, all channels, no load, EN1 at 3 V, EN2 at 3 V		4.5	7	mA
		25 Mbps			6.5	11	
I_{CC2}	ISO7230C/M	Quiescent	$V_I = V_{CC1}$ or 0 V, all channels, no load, EN at 3 V		9	15	mA
		25 Mbps			10	17	
	ISO7231C/M	Quiescent	$V_I = V_{CC1}$ or 0 V, all channels, no load, EN1 at 3 V, EN2 at 3 V		8	12	mA
		25 Mbps			10.5	16	
ELECTRICAL CHARACTERISTICS							
I_{OFF}	Sleep mode output current	ENx at 0 V, single channel			0		μ A
V_{OH}	High-level output voltage	$I_{OH} = -4$ mA, See Figure 8		$V_{CC0} - 0.4$			V
		$I_{OH} = -20$ μ A, See Figure 8		$V_{CC0} - 0.1$			
V_{OL}	Low-level output voltage	$I_{OL} = 4$ mA, See Figure 8				0.4	V
		$I_{OL} = 20$ μ A, See Figure 8				0.1	
$V_{I(HYS)}$	Input voltage hysteresis			150			mV
I_{IH}	High-level input current	INx at V_{CC1}				10	μ A
I_{IL}	Low-level input current	INx at 0 V		-10			
C_I	Input capacitance to ground	INx at V_{CC1} , $V_I = 0.4 \sin(4E6\pi t)$				2	pF
CMTI	Common-mode transient immunity	$V_I = V_{CC1}$ or 0 V, See Figure 11		25	50		kV/ μ s

- (1) For the 5-V operation, V_{CC1} or V_{CC2} is specified from 4.5 V to 5.5 V.
 For the 3.3-V operation, V_{CC1} or V_{CC2} is specified from 3.15 V to 3.6 V.

7.9 Power Dissipation Characteristics

over operating free-air temperature range (unless otherwise noted)

PARAMETER		ISO7230C, ISO7230M, ISO7231C, ISO7231M		UNIT
		DW (SOIC)		
		16 PINS		
P_D	Device power dissipation, $V_{CC1} = V_{CC2} = 5.5$ V, $T_J = 150^\circ\text{C}$, $C_L = 15$ pF, D Input a 50% duty cycle square wave	220		mW

7.10 Switching Characteristics: V_{CC1} and V_{CC2} at 5-V

over recommended operating conditions (unless otherwise noted)

PARAMETER		TEST CONDITIONS	MIN	TYP	MAX	UNIT	
t_{PLH} , t_{PHL}	Propagation delay	ISO723xC See Figure 8	18		42	ns	
PWD	Pulse-width distortion ⁽¹⁾ $ t_{PHL} - t_{PLH} $				2.5		
t_{PLH} , t_{PHL}	Propagation delay	ISO723xM	10		23	ns	
PWD	Pulse-width distortion ⁽¹⁾ $ t_{PHL} - t_{PLH} $				1		2
$t_{sk(pp)}$	Part-to-part skew ⁽²⁾	ISO723xC			8	ns	
		ISO723xM			0		3
$t_{sk(o)}$	Channel-to-channel output skew ⁽³⁾	ISO723xC			0	2	ns
		ISO723xM			0	1	
t_r	Output signal rise time	See Figure 8			2	ns	
t_f	Output signal fall time				2		
t_{PHZ}	Propagation delay, high-level-to-high-impedance output	See Figure 9			15	20	ns
t_{PZH}	Propagation delay, high-impedance-to-high-level output				15	20	
t_{PLZ}	Propagation delay, low-level-to-high-impedance output				15	20	
t_{PZL}	Propagation delay, high-impedance-to-low-level output				15	20	
t_{fs}	Failsafe output delay time from input power loss	See Figure 10			12	μ s	
$t_{jit(pp)}$	Peak-to-peak eye-pattern jitter	ISO723xM	150 Mbps PRBS NRZ data input, Same polarity input on all channels, See Figure 12			1	ns

- (1) Also referred to as pulse skew.
- (2) $t_{sk(pp)}$ is the magnitude of the difference in propagation delay times between any specified terminals of two devices when both devices operate with the same supply voltages, at the same temperature, and have identical packages and test circuits.
- (3) $t_{sk(o)}$ is the skew between specified outputs of a single device with all driving inputs connected together and the outputs switching in the same direction while driving identical specified loads.

7.11 Switching Characteristics: V_{CC1} at 5-V, V_{CC2} at 3.3-V

over recommended operating conditions (unless otherwise noted)

PARAMETER		TEST CONDITIONS	MIN	TYP	MAX	UNIT	
t_{PLH} , t_{PHL}	Propagation delay, low-to-high-level output	See Figure 8	20		50	ns	
PWD	Pulse-width distortion ⁽¹⁾ $ t_{PHL} - t_{PLH} $				3		
t_{PLH} , t_{PHL}	Propagation delay, low-to-high-level output		12		29		
PWD	Pulse-width distortion ⁽¹⁾ $ t_{PHL} - t_{PLH} $				1		2
$t_{sk(pp)}$	Part-to-part skew ⁽²⁾	ISO723xC			10	ns	
		ISO723xM			0		5
$t_{sk(o)}$	Channel-to-channel output skew ⁽³⁾	ISO723xC			0	2.5	ns
		ISO723xM			0	1	
t_r	Output signal rise time	See Figure 8			2	ns	
t_f	Output signal fall time				2		
t_{PHZ}	Propagation delay, high-level-to-high-impedance output	See Figure 9			15	20	ns
t_{PZH}	Propagation delay, high-impedance-to-high-level output				15	20	
t_{PLZ}	Propagation delay, low-level-to-high-impedance output				15	20	
t_{PZL}	Propagation delay, high-impedance-to-low-level output				15	20	
t_{fs}	Failsafe output delay time from input power loss	See Figure 10			18	μ s	
$t_{jit(pp)}$	Peak-to-peak eye-pattern jitter	ISO723xM	150 Mbps PRBS NRZ data input, Same polarity input on all channels, See Figure 12			1	ns

(1) Also known as pulse skew

(2) $t_{sk(pp)}$ is the magnitude of the difference in propagation delay times between any specified terminals of two devices when both devices operate with the same supply voltages, at the same temperature, and have identical packages and test circuits.

(3) $t_{sk(o)}$ is the skew between specified outputs of a single device with all driving inputs connected together and the outputs switching in the same direction while driving identical specified loads.

7.12 Switching Characteristics: V_{CC1} at 3.3-V and V_{CC2} at 5-V

, over recommended operating conditions (unless otherwise noted)

PARAMETER			TEST CONDITIONS	MIN	TYP	MAX	UNIT	
t_{PLH} , t_{PHL}	Propagation delay			ISO723xC	See Figure 8	22		51
PWD	Pulse-width distortion ⁽¹⁾ $ t_{PHL} - t_{PLH} $					3		
t_{PLH} , t_{PHL}	Propagation delay	ISO723xM	12			30	ns	
PWD	Pulse-width distortion ⁽¹⁾ $ t_{PHL} - t_{PLH} $					1		2
$t_{sk(pp)}$	Part-to-part skew ⁽²⁾	ISO723xC	See Figure 8			10	ns	
		ISO723xM		0		5		
$t_{sk(o)}$	Channel-to-channel output skew ⁽³⁾	ISO723xC	See Figure 8			0	ns	
		ISO723xM		0		1		
t_r	Output signal rise time		See Figure 8			2	ns	
t_f	Output signal fall time					2		
t_{PHZ}	Propagation delay, high-level-to-high-impedance output		See Figure 9			15	ns	
t_{PZH}	Propagation delay, high-impedance-to-high-level output					15		20
t_{PLZ}	Propagation delay, low-level-to-high-impedance output					15		20
t_{PZL}	Propagation delay, high-impedance-to-low-level output					15		20
t_{fs}	Failsafe output delay time from input power loss		See Figure 10			12	μ s	
$t_{jit(pp)}$	Peak-to-peak eye-pattern jitter	ISO723xM	150 Mbps PRBS NRZ data input, Same polarity input on all channels, See Figure 12			1	ns	

(1) Also known as pulse skew

 (2) $t_{sk(pp)}$ is the magnitude of the difference in propagation delay times between any specified terminals of two devices when both devices operate with the same supply voltages, at the same temperature, and have identical packages and test circuits.

 (3) $t_{sk(o)}$ is the skew between specified outputs of a single device with all driving inputs connected together and the outputs switching in the same direction while driving identical specified loads.

7.13 Switching Characteristics: V_{CC1} and V_{CC2} at 3.3-V

over recommended operating conditions (unless otherwise noted)

PARAMETER			TEST CONDITIONS	MIN	TYP	MAX	UNIT	
t_{PLH} , t_{PHL}	Propagation delay			ISO723xC	See Figure 8	25		56
PWD	Pulse-width distortion ⁽¹⁾ $ t_{PHL} - t_{PLH} $					4		
t_{PLH} , t_{PHL}	Propagation delay	ISO723xM	12			34	ns	
PWD	Pulse-width distortion ⁽¹⁾ $ t_{PHL} - t_{PLH} $					1		2
$t_{sk(pp)}$	Part-to-part skew ⁽²⁾	ISO723xC	See Figure 8			10	ns	
		ISO723xM		0		5		
$t_{sk(o)}$	Channel-to-channel output skew ⁽³⁾	ISO723xC	See Figure 8			0	ns	
		ISO723xM		0		1		
t_r	Output signal rise time		See Figure 8			2	ns	
t_f	Output signal fall time					2		
t_{PHZ}	Propagation delay, high-level-to-high-impedance output		See Figure 9			15	ns	
t_{PZH}	Propagation delay, high-impedance-to-high-level output					15		20
t_{PLZ}	Propagation delay, low-level-to-high-impedance output					15		20
t_{PZL}	Propagation delay, high-impedance-to-low-level output					15		20
t_{fs}	Failsafe output delay time from input power loss		See Figure 10			18	μ s	
$t_{jit(pp)}$	Peak-to-peak eye-pattern jitter	ISO723xM	150 Mbps PRBS NRZ data input, same polarity input on all channels, See Figure 12			1	ns	

(1) Also referred to as pulse skew.

 (2) $t_{sk(pp)}$ is the magnitude of the difference in propagation delay times between any specified terminals of two devices when both devices operate with the same supply voltages, at the same temperature, and have identical packages and test circuits.

 (3) $t_{sk(o)}$ is the skew between specified outputs of a single device with all driving inputs connected together and the outputs switching in the same direction while driving identical specified loads.

7.14 Typical Characteristics

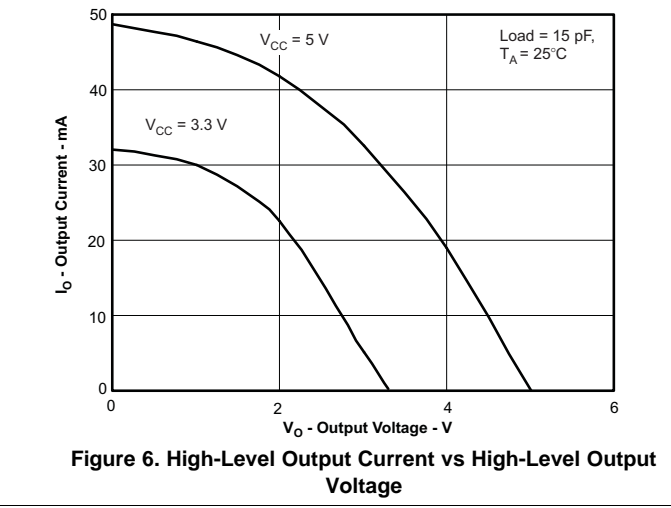
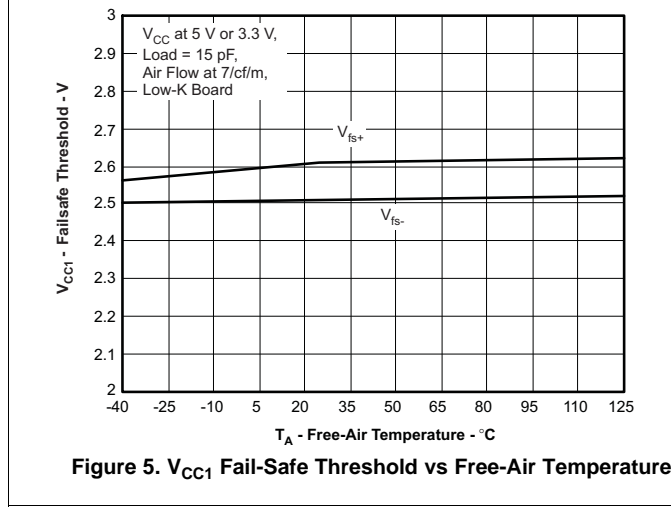
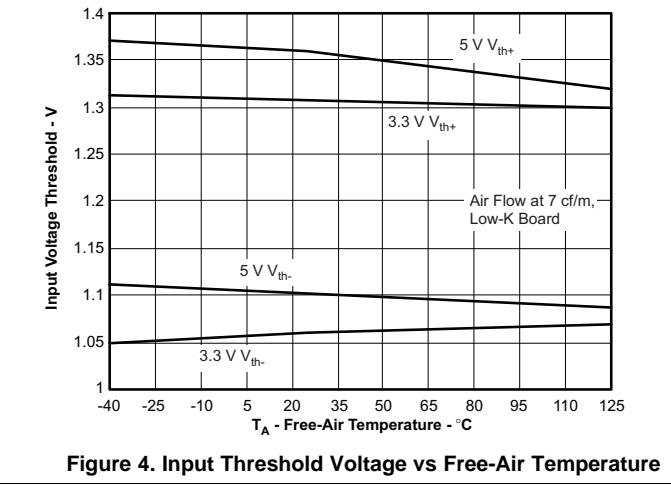
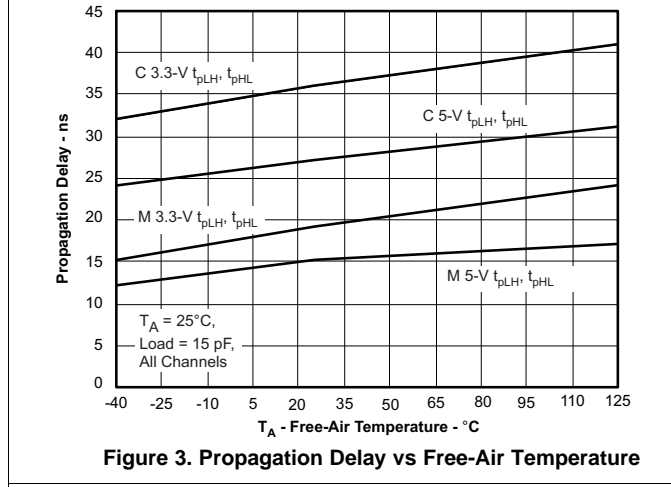
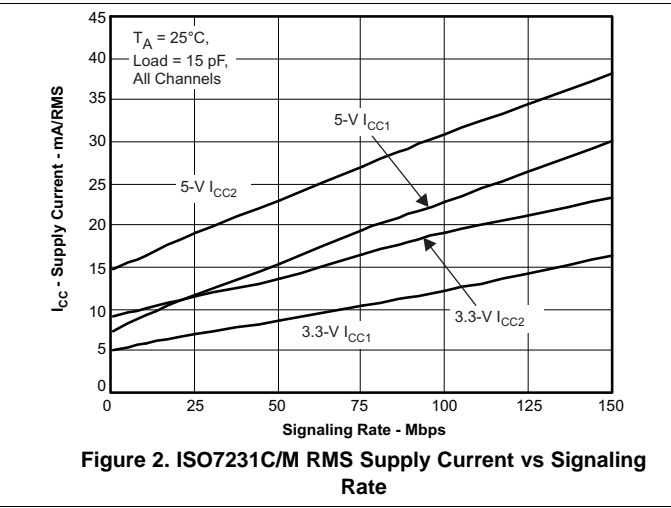
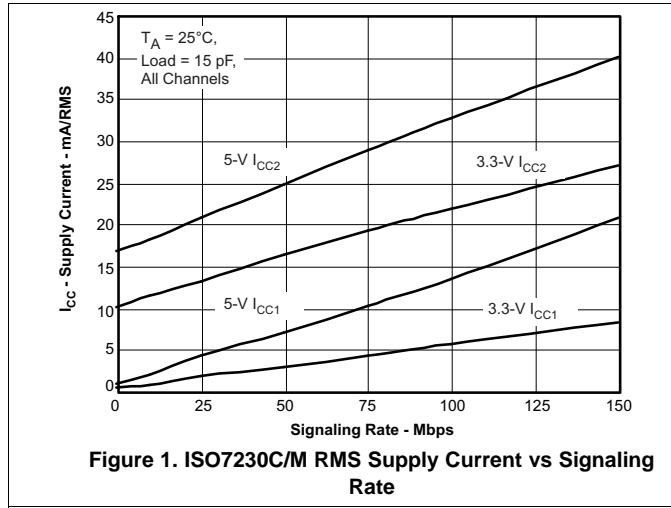

Typical Characteristics (continued)

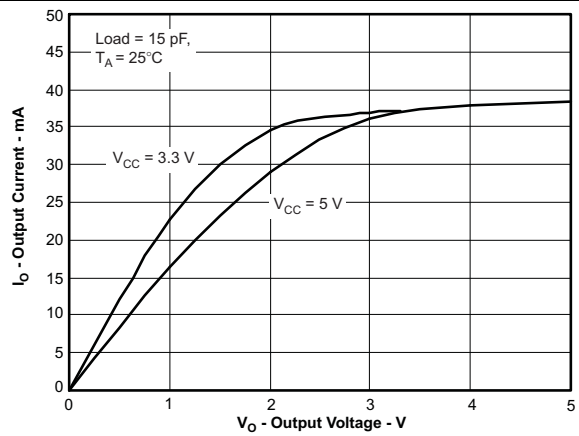
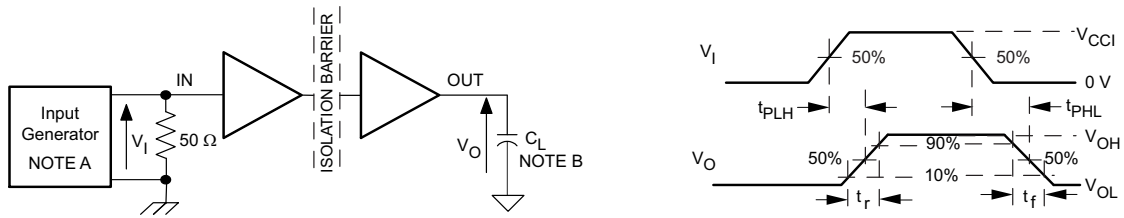

Figure 7. Low-Level Output Current vs Low-Level Output Voltage

8 Parameter Measurement Information



- A. The input pulse is supplied by a generator having the following characteristics: PRR \leq 50 kHz, 50% duty cycle, $t_r \leq$ 3 ns, $t_f \leq$ 3 ns, $Z_O = 50 \Omega$. At the input, a 50- Ω resistor is required to terminate the Input Generator signal. It is not needed in actual application.
- B. $C_L = 15$ pF and includes instrumentation and fixture capacitance within $\pm 20\%$.

Figure 8. Switching Characteristic Test Circuit and Voltage Waveforms

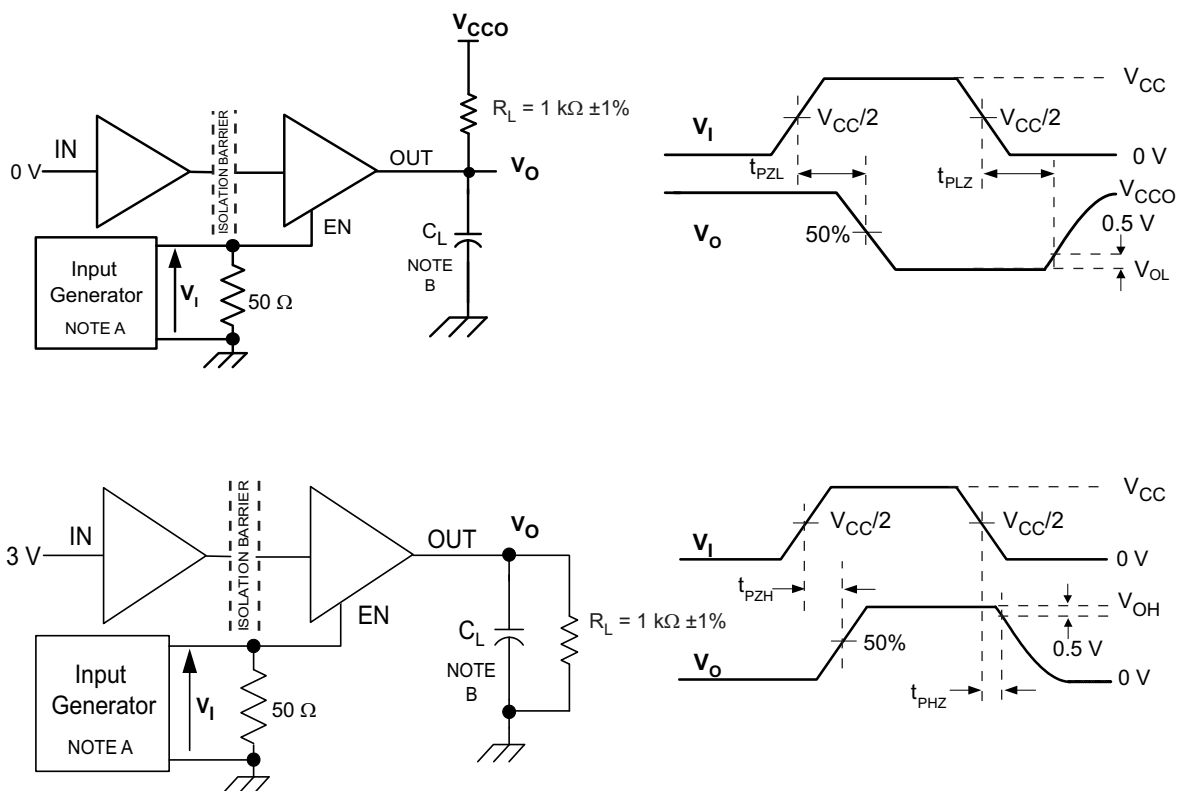

- A. The input pulse is supplied by a generator having the following characteristics: PRR \leq 50 kHz, 50% duty cycle, $t_r \leq$ 3 ns, $t_f \leq$ 3 ns, $Z_O = 50 \Omega$.
- B. $C_L = 15$ pF and includes instrumentation and fixture capacitance within $\pm 20\%$.

Figure 9. Enable/Disable Propagation Delay Time Test Circuit and Waveform

Parameter Measurement Information (continued)

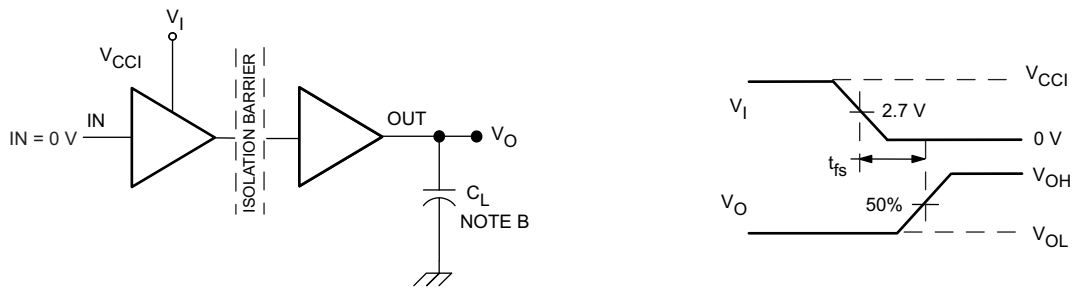

- A. The input pulse is supplied by a generator having the following characteristics: PRR \leq 50 kHz, 50% duty cycle, $t_r \leq$ 3 ns, $t_f \leq$ 3 ns, $Z_O = 50 \Omega$.
- B. $C_L = 15$ pF and includes instrumentation and fixture capacitance within $\pm 20\%$.

Figure 10. Failsafe Delay Time Test Circuit and Voltage Waveforms

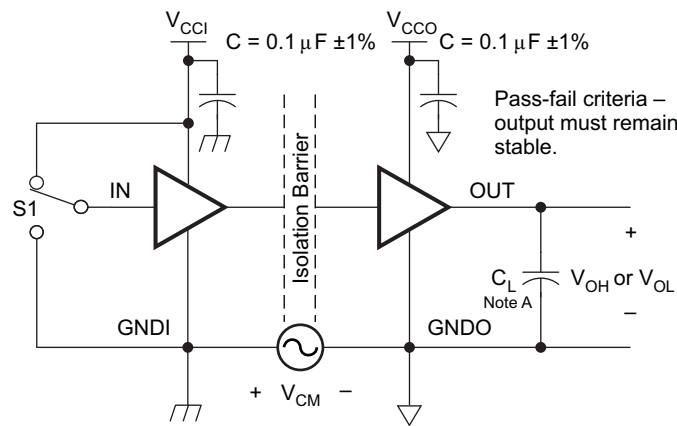

- A. $C_L = 15$ pF and includes instrumentation and fixture capacitance within $\pm 20\%$.

Figure 11. Common-Mode Transient Immunity Test Circuit

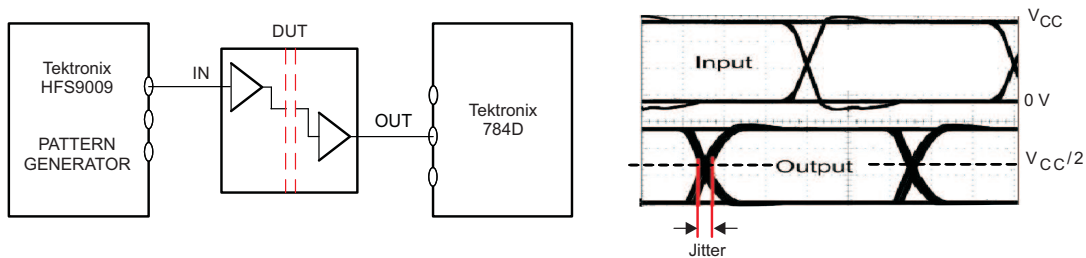

NOTE: PRBS bit pattern run length is $2^{16} - 1$. Transition time is 800 ps. NRZ data input has no more than five consecutive 1s or 0s.

Figure 12. Peak-to-Peak Eye-Pattern Jitter Test Circuit and Voltage Waveform

9 Detailed Description

9.1 Overview

The isolator in [Figure 13](#) is based on a capacitive isolation barrier technique. The I/O channel of the device consists of two internal data channels, a high-frequency channel (HF) with a bandwidth from 100 kbps up to 150 Mbps, and a low-frequency channel (LF) covering the range from 100 kbps down to DC. In principle, a single-ended input signal entering the HF-channel is split into a differential signal via the inverter gate at the input. The following capacitor-resistor networks differentiate the signal into transients, which then are converted into differential pulses by two comparators. The comparator outputs drive a NOR-gate flip-flop whose output feeds an output multiplexer. A decision logic (DCL) at the driving output of the flip-flop measures the durations between signal transients. If the duration between two consecutive transients exceeds a certain time limit, (as in the case of a low-frequency signal), the DCL forces the output-multiplexer to switch from the high- to the low-frequency channel.

Because low-frequency input signals require the internal capacitors to assume prohibitively large values, these signals are pulse-width modulated (PWM) with the carrier frequency of an internal oscillator, thus creating a sufficiently high frequency signal, capable of passing the capacitive barrier. As the input is modulated, a low-pass filter (LPF) is needed to remove the high-frequency carrier from the actual data before passing it on to the output multiplexer.

9.2 Functional Block Diagram

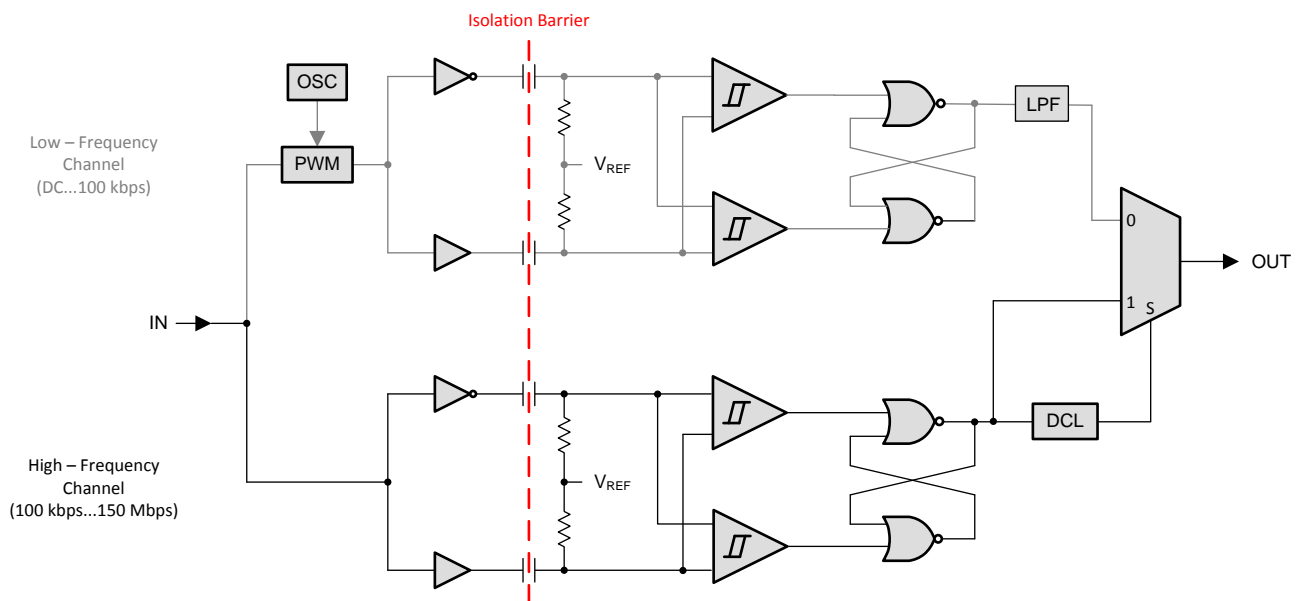

Figure 13. Conceptual Block Diagram of a Digital Capacitive Isolator

9.3 Feature Description

9.3.1 Package Insulation and Safety-Related Specifications

PARAMETER	TEST CONDITIONS	MIN	TYP	MAX	UNIT
L(I01) Minimum air gap (Clearance) ⁽¹⁾	Shortest terminal-to-terminal distance through air	8			mm
L(I02) Minimum external tracking (Creepage) ⁽¹⁾	Shortest terminal-to-terminal distance across the package surface	8			mm
CTI Tracking resistance (comparative tracking index)	DIN EN 60112 (VDE 0303-11); IEC 60112	400			V
DTI Minimum Internal Gap (Internal Clearance)	Distance through the insulation	0.008			mm
R _{IO} ⁽²⁾ Isolation resistance	Input to output, V _{IO} = 500 V, T _A = 25°C	>10 ¹²			Ω
	Input to output, V _{IO} = 500 V, 100°C ≤ T _A ≤ T _A max	>10 ¹¹			Ω
C _{IO} ⁽²⁾ Barrier capacitance Input to output	V _I = 0.4 sin (4E6πt)		2		pF

(1) per JEDEC package dimensions.

(2) All pins on each side of the barrier tied together creating a two-terminal device.

9.3.2 Insulation Characteristics

PARAMETER	TEST CONDITIONS	SPECIFICATION	UNIT
DIN V VDE V 0884-10 (VDE V 0884-10):2006-12⁽¹⁾			
V _{IORM} Maximum repetitive peak isolation voltage		560	V _{PK}
V _{PR} Input to output test voltage	Method b1, V _{PR} = V _{IORM} × 1.875, 100% production test with t = 1 s, Partial discharge < 5 pC	1050	V _{PK}
V _{IOTM} Maximum transient isolation voltage	V _{TEST} = V _{IOTM} , t = 60 s (qualification), t = 1 s (100% production)	4000	V _{PK}
R _S Isolation resistance	V _{IO} = 500 V at T _S = 150 °C	>10 ⁹	Ω
Pollution degree		2	
UL 1577			
V _{ISO} Withstanding isolation voltage	V _{TEST} = V _{ISO} = 2500 V _{RMS} , t = 60 s (qualification), V _{TEST} = 1.2 × V _{ISO} = 3000 V _{RMS} , t = 1 s (100% production)	2500	V _{RMS}

(1) Climatic classification 40/125/21

Table 1. IEC 60664-1 Ratings Table

PARAMETER	TEST CONDITIONS	SPECIFICATION
Basic isolation group	Material group	II
Installation classification	Rated mains voltage ≤ 150 V _{RMS}	I-IV
	Rated mains voltage ≤ 300 V _{RMS}	I-III

9.3.3 Regulatory Information

VDE	CSA	UL
Certified according to DIN V VDE V 0884-10 (VDE V 0884-10):2006-12 and DIN EN 61010-1 (VDE 0411-1):2011-07	Approved under CSA Component Acceptance Notice 5A and IEC 60950-1	Recognized under UL 1577 Component Recognition Program
Basic insulation; Maximum transient isolation voltage, 4000 V _{PK} ; Maximum repetitive peak isolation voltage, 560 V _{PK}	4000 V _{PK} Isolation rating; 384 V _{RMS} Basic insulation working voltage per CSA 60950-1-07+A1 and IEC 60950-1 2nd Ed.+A1	Single protection, 2500 V _{RMS}
File Number: 40016131	Master Contract Number: 220991	File Number: E181974

9.3.4 Safety Limiting Values

Safety limiting intends to prevent potential damage to the isolation barrier upon failure of input or output circuitry. A failure of the IO can allow low resistance to ground or the supply and, without current limiting, dissipate sufficient power to overheat the die and damage the isolation barrier potentially leading to secondary system failures.

PARAMETER	TEST CONDITIONS	MIN	TYP	MAX	UNIT
I_S Safety input, output, or supply current	SOIC-16 $\theta_{JA} = 168^\circ\text{C}/\text{W}$, $V_I = 5.5\text{ V}$, $T_J = 170^\circ\text{C}$, $T_A = 25^\circ\text{C}$			156	mA
	$\theta_{JA} = 168^\circ\text{C}/\text{W}$, $V_I = 3.6\text{ V}$, $T_J = 170^\circ\text{C}$, $T_A = 25^\circ\text{C}$			239	
T_S Maximum case temperature	SOIC-16			150	$^\circ\text{C}$

The safety-limiting constraint is the absolute maximum junction temperature specified in the absolute maximum ratings table. The power dissipation and junction-to-air thermal impedance of the device installed in the application hardware determines the junction temperature. The assumed junction-to-air thermal resistance in the Thermal Characteristics table is that of a device installed in the JESD51-3, Low Effective Thermal Conductivity Test Board for Leaded Surface Mount Packages and is conservative. The power is the recommended maximum input voltage times the current. The junction temperature is then the ambient temperature plus the power times the junction-to-air thermal resistance.

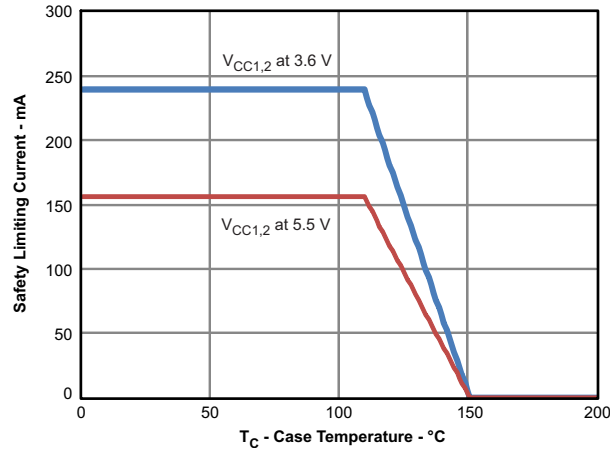

Figure 14. SOIC-16 θ_{JC} Thermal Derating Curve per VDE

9.4 Device Functional Modes

Table 2. Device Function Table ISO723x ⁽¹⁾

V_{CCI}	V_{CCO}	INPUT (INx)	OUTPUT ENABLE (ENx)	OUTPUT (OUTx)
PU	PU	H	H or Open	H
		L	H or Open	L
		X	L	Z
		Open	H or Open	H
PD	PU	X	H or Open	H
PD	PU	X	L	Z
X	PD	X	X	Undetermined

(1) V_{CCI} = Input-side V_{CC} ; V_{CCO} = Output-side V_{CC} ; PU = Powered Up; PD = Powered Down; X = Irrelevant; H = High Level; L = Low Level

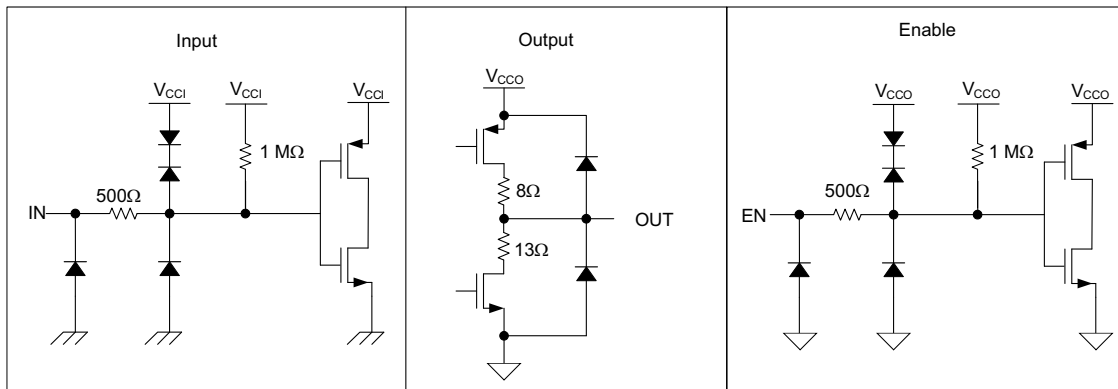

Figure 15. Device I/O Schematics

Typical Application (continued)

10.2.2 Detailed Design Procedure

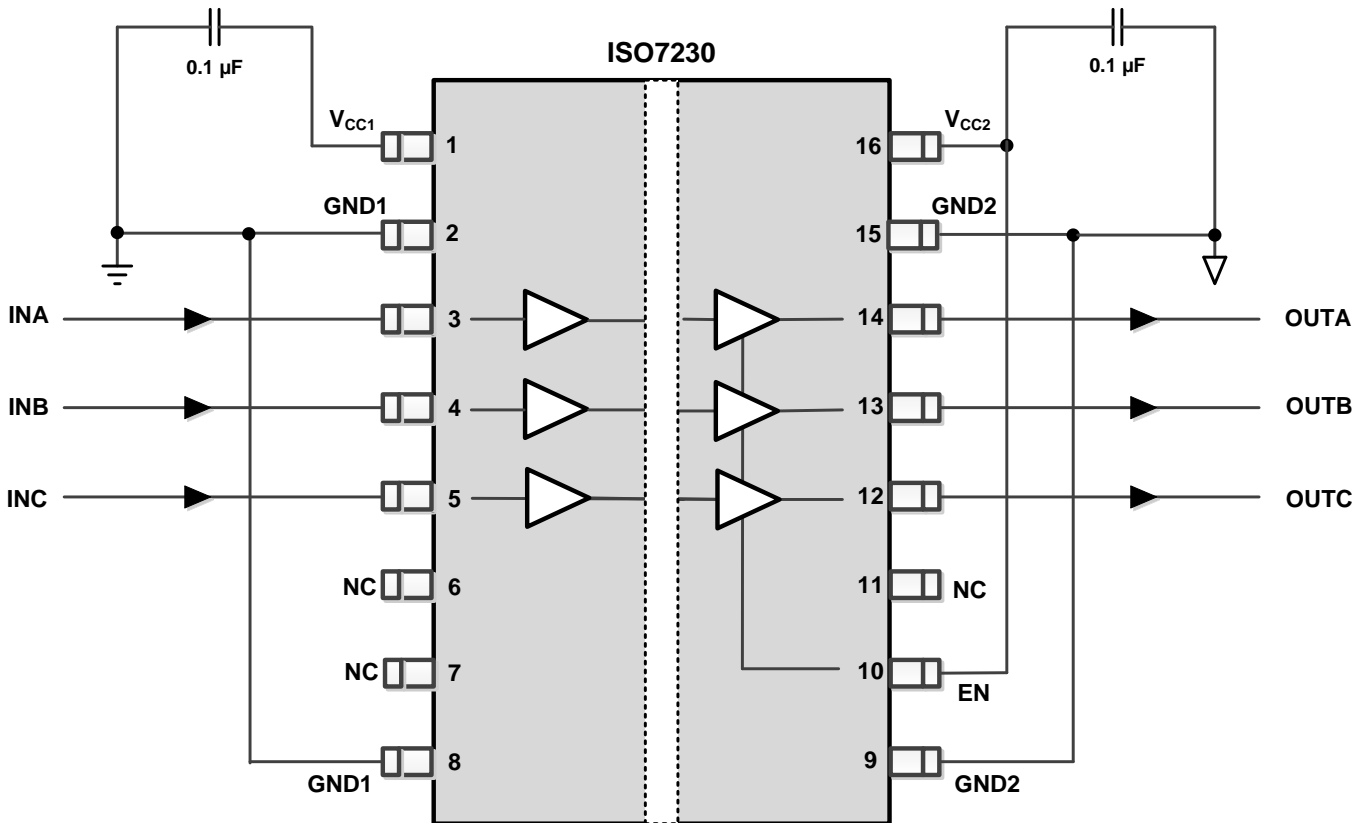

Figure 17. Typical ISO7230 Circuit Hook-up

Typical Application (continued)

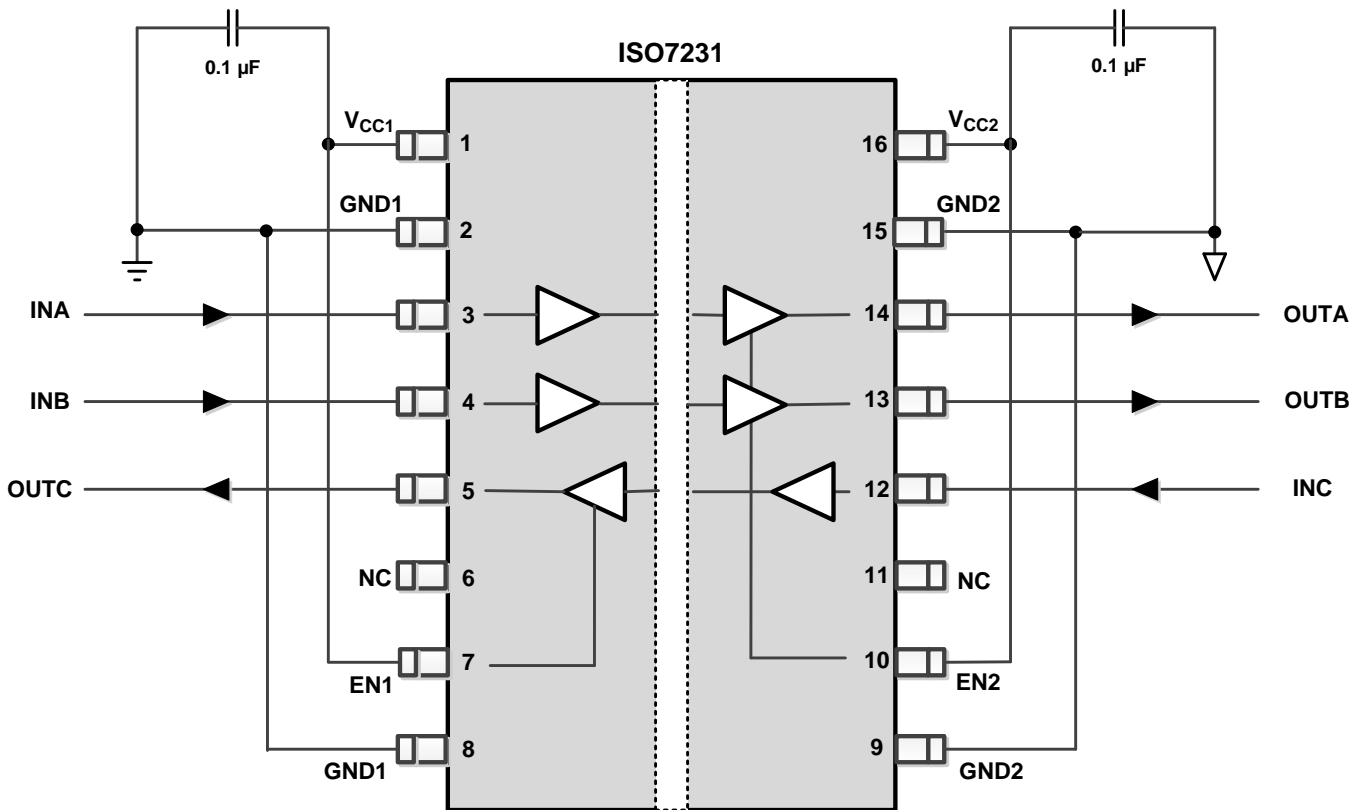

Figure 18. Typical ISO7231 Circuit Hook-up

10.2.3 Application Curve

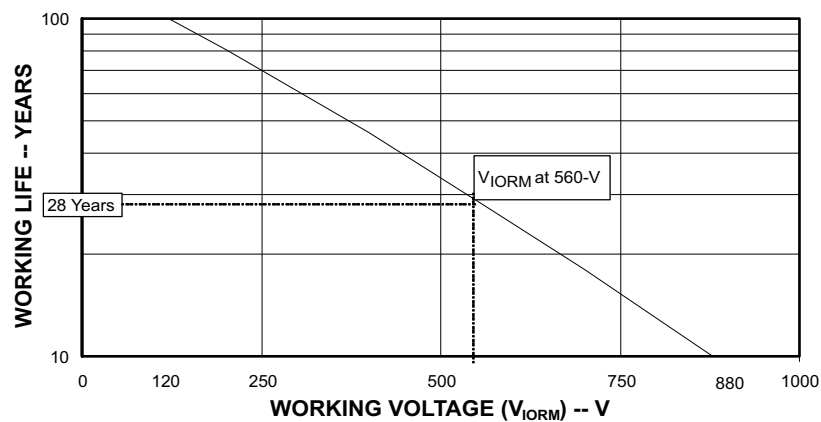

Figure 19. Time Dependant Dielectric Breakdown Testing Results

11 Power Supply Recommendations

To ensure reliable operation at all data rates and supply voltages, a 0.1 μF bypass capacitor is recommended at input and output supply pins (V_{CC1} and V_{CC2}). The capacitors should be placed as close to the supply pins as possible. If only a single primary-side power supply is available in an application, isolated power can be generated for the secondary-side with the help of a transformer driver such as Texas Instruments SN6501 data sheet. For such applications, detailed power supply design and transformer selection recommendations are available in SN6501 data sheet ([SLLSEA0](#)).

12 Layout

12.1 Layout Guidelines

A minimum of four layers is required to accomplish a low EMI PCB design (see [Figure 20](#)). Layer stacking should be in the following order (top-to-bottom): high-speed signal layer, ground plane, power plane and low-frequency signal layer.

- Routing the high-speed traces on the top layer avoids the use of vias (and the introduction of their inductances) and allows for clean interconnects between the isolator and the transmitter and receiver circuits of the data link.
- Placing a solid ground plane next to the high-speed signal layer establishes controlled impedance for transmission line interconnects and provides an excellent low-inductance path for the return current flow.
- Placing the power plane next to the ground plane creates additional high-frequency bypass capacitance of approximately 100pF/in².
- Routing the slower speed control signals on the bottom layer allows for greater flexibility as these signal links usually have margin to tolerate discontinuities such as vias.

If an additional supply voltage plane or signal layer is needed, add a second power/ground plane system to the stack to keep it symmetrical. This makes the stack mechanically stable and prevents it from warping. Also the power and ground plane of each power system can be placed closer together, thus increasing the high-frequency bypass capacitance significantly. For detailed layout recommendations, see Application Note [SLLA284](#), *Digital Isolator Design Guide*.

12.1.1 PCB Material

For digital circuit boards operating below 150 Mbps, (or rise and fall times higher than 1 ns), and trace lengths of up to 10 inches, use standard FR-4 epoxy-glass as PCB material. FR-4 (Flame Retardant 4) meets the requirements of Underwriters Laboratories UL94-V0, and is preferred over cheaper alternatives due to its lower dielectric losses at high frequencies, less moisture absorption, greater strength and stiffness, and its self-extinguishing flammability-characteristics.

12.2 Layout Example

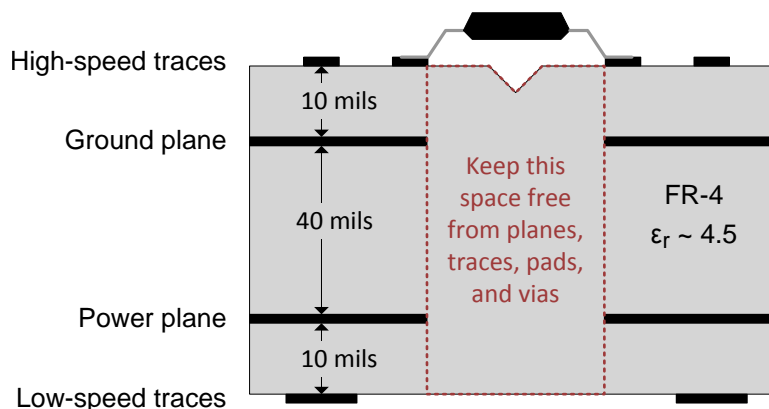

Figure 20. Recommended Layer Stack

13 Device and Documentation Support

13.1 Related Documentation

- *High-Voltage Lifetime of the ISO72x Family of Digital Isolators*, [SLLA197](#)
- *ISO72x Digital Isolator Magnetic-Field Immunity*, [SLLA181](#)
- *SN6501 Transformer Driver for Isolated Power Supplies*, [SLLSEA0](#)
- *Digital Isolator Design Guide*, [SLLA284](#)
- *Isolation Glossary*, [SLLA353](#)

13.2 Related Links

The table below lists quick access links. Categories include technical documents, support and community resources, tools and software, and quick access to sample or buy.

Table 3. Related Links

PARTS	PRODUCT FOLDER	SAMPLE & BUY	TECHNICAL DOCUMENTS	TOOLS & SOFTWARE	SUPPORT & COMMUNITY
ISO7230C	Click here	Click here	Click here	Click here	Click here
ISO7230M	Click here	Click here	Click here	Click here	Click here
ISO7231C	Click here	Click here	Click here	Click here	Click here
ISO7231M	Click here	Click here	Click here	Click here	Click here

13.3 Community Resources

The following links connect to TI community resources. Linked contents are provided "AS IS" by the respective contributors. They do not constitute TI specifications and do not necessarily reflect TI's views; see TI's [Terms of Use](#).

TI E2E™ Online Community *TI's Engineer-to-Engineer (E2E) Community*. Created to foster collaboration among engineers. At e2e.ti.com, you can ask questions, share knowledge, explore ideas and help solve problems with fellow engineers.

Design Support *TI's Design Support* Quickly find helpful E2E forums along with design support tools and contact information for technical support.

13.4 Trademarks

E2E is a trademark of Texas Instruments.
All other trademarks are the property of their respective owners.

13.5 Electrostatic Discharge Caution



These devices have limited built-in ESD protection. The leads should be shorted together or the device placed in conductive foam during storage or handling to prevent electrostatic damage to the MOS gates.

13.6 Glossary

[SLYZ022](#) — *TI Glossary*.

This glossary lists and explains terms, acronyms, and definitions.

14 Mechanical, Packaging, and Orderable Information

The following pages include mechanical, packaging, and orderable information. This information is the most current data available for the designated devices. This data is subject to change without notice and revision of this document. For browser-based versions of this data sheet, refer to the left-hand navigation.

DW0016B

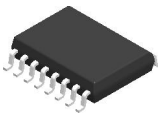

SOIC - 2.65 mm max height

SOIC

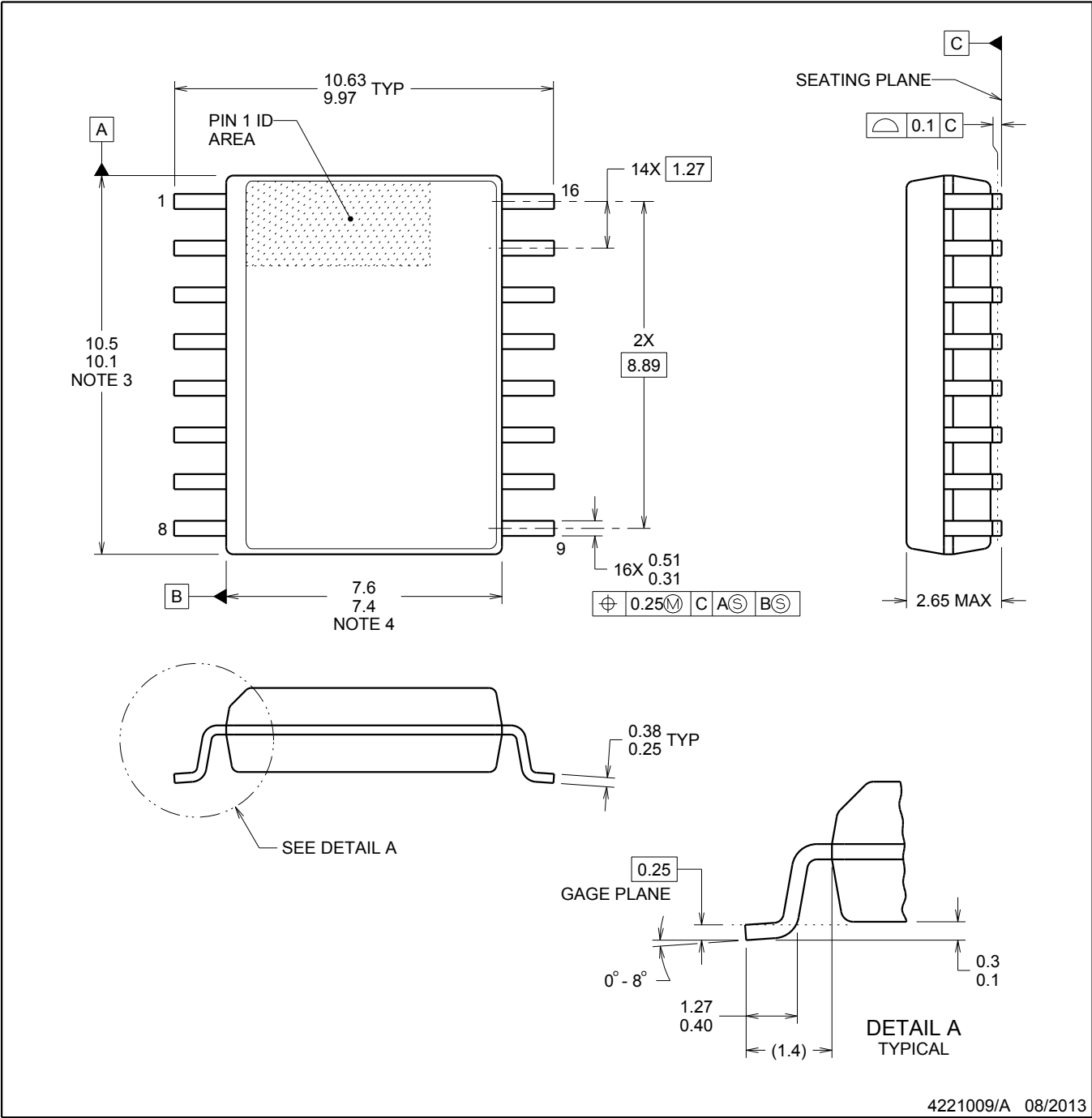

4221009/A 08/2013

NOTES:

1. All linear dimensions are in millimeters. Dimensions in parenthesis are for reference only. Dimensioning and tolerancing per ASME Y14.5M.
2. This drawing is subject to change without notice.
3. This dimension does not include mold flash, protrusions, or gate burrs. Mold flash, protrusions, or gate burrs shall not exceed 0.15 mm, per side.
4. This dimension does not include interlead flash. Interlead flash shall not exceed 0.25 mm, per side.
5. Reference JEDEC registration MO-013, variation AA.

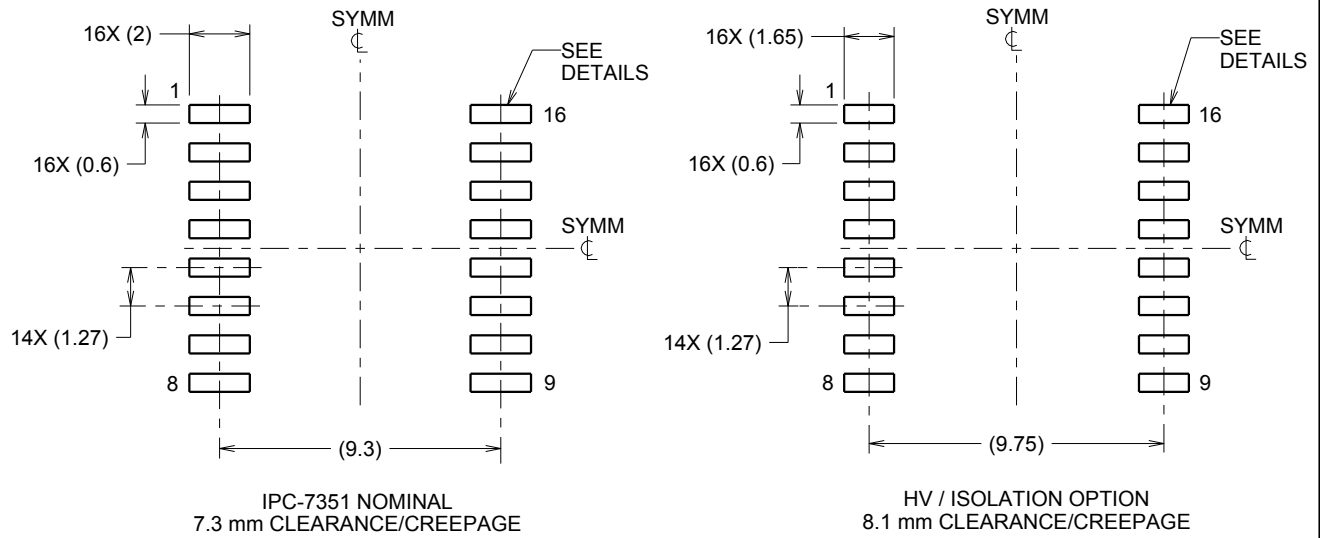

LAND PATTERN EXAMPLE
SCALE:4X

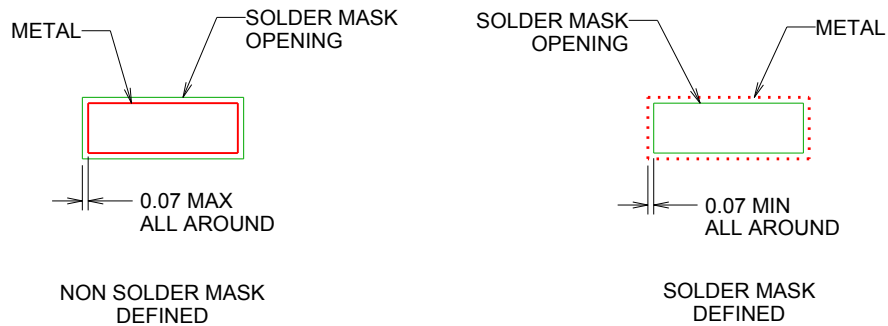

SOLDER MASK DETAILS

4221009/A 08/2013

NOTES: (continued)

6. Publication IPC-7351 may have alternate designs.
7. Solder mask tolerances between and around signal pads can vary based on board fabrication site.

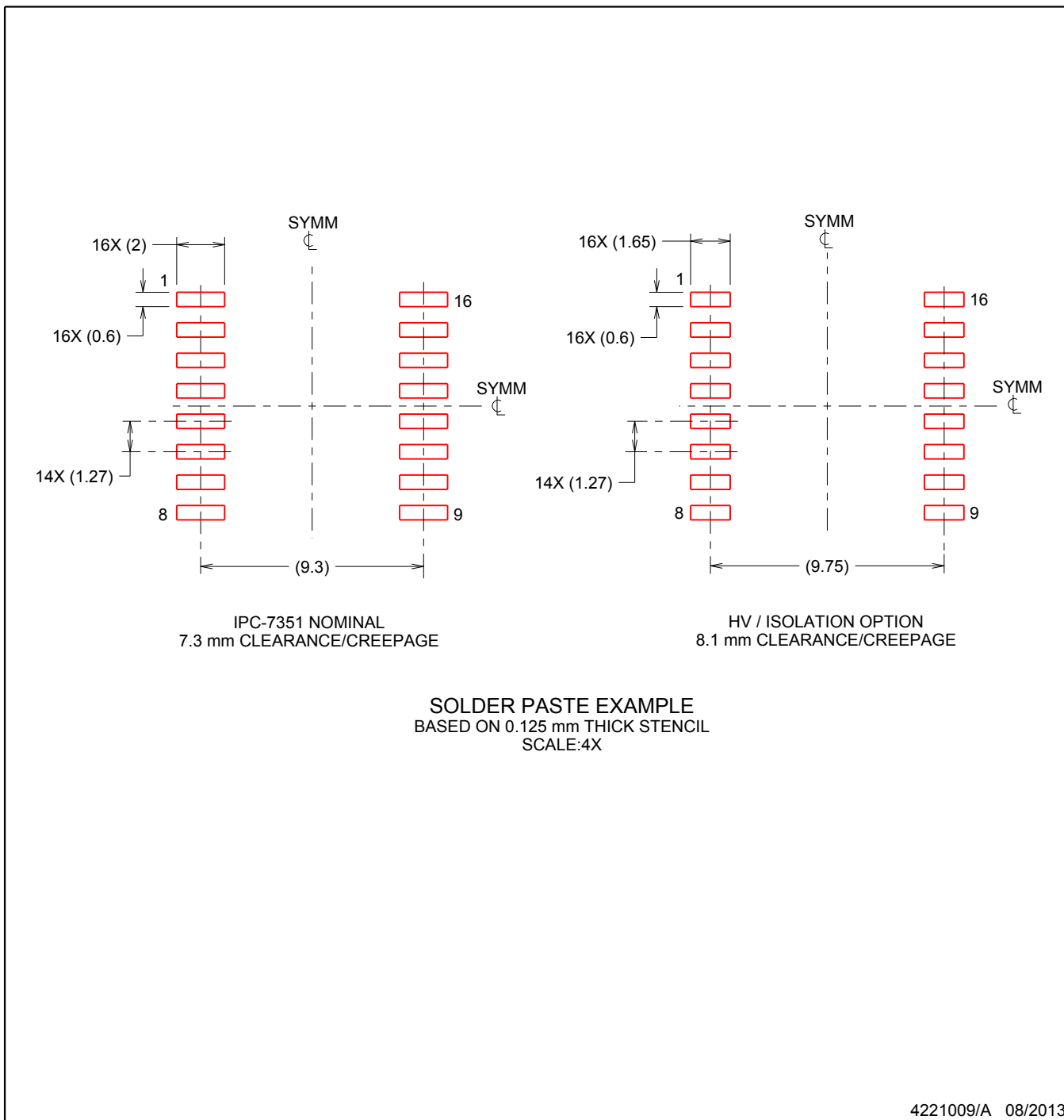

NOTES: (continued)

- 8. Laser cutting apertures with trapezoidal walls and rounded corners may offer better paste release. IPC-7525 may have alternate design recommendations.
- 9. Board assembly site may have different recommendations for stencil design.

PACKAGING INFORMATION

Orderable Device	Status (1)	Package Type	Package Drawing	Pins	Package Qty	Eco Plan (2)	Lead finish/ Ball material (6)	MSL Peak Temp (3)	Op Temp (°C)	Device Marking (4/5)	Samples
ISO7230CDW	ACTIVE	SOIC	DW	16	40	RoHS & Green	NIPDAU	Level-2-260C-1 YEAR	-40 to 125	ISO7230C	Samples
ISO7230CDWG4	ACTIVE	SOIC	DW	16	40	RoHS & Green	NIPDAU	Level-2-260C-1 YEAR	-40 to 125	ISO7230C	Samples
ISO7230CDWR	ACTIVE	SOIC	DW	16	2000	RoHS & Green	NIPDAU	Level-2-260C-1 YEAR	-40 to 125	ISO7230C	Samples
ISO7230MDW	ACTIVE	SOIC	DW	16	40	RoHS & Green	NIPDAU	Level-2-260C-1 YEAR	-40 to 125	ISO7230M	Samples
ISO7230MDWR	ACTIVE	SOIC	DW	16	2000	RoHS & Green	NIPDAU	Level-2-260C-1 YEAR	-40 to 125	ISO7230M	Samples
ISO7231CDW	ACTIVE	SOIC	DW	16	40	RoHS & Green	NIPDAU	Level-2-260C-1 YEAR	-40 to 125	ISO7231C	Samples
ISO7231CDWR	ACTIVE	SOIC	DW	16	2000	RoHS & Green	NIPDAU	Level-2-260C-1 YEAR	-40 to 125	ISO7231C	Samples
ISO7231CDWRG4	ACTIVE	SOIC	DW	16	2000	RoHS & Green	NIPDAU	Level-2-260C-1 YEAR	-40 to 125	ISO7231C	Samples
ISO7231MDW	ACTIVE	SOIC	DW	16	40	RoHS & Green	NIPDAU	Level-2-260C-1 YEAR	-40 to 125	ISO7231M	Samples
ISO7231MDWR	ACTIVE	SOIC	DW	16	2000	RoHS & Green	NIPDAU	Level-2-260C-1 YEAR	-40 to 125	ISO7231M	Samples
ISO7231MDWRG4	ACTIVE	SOIC	DW	16	2000	RoHS & Green	NIPDAU	Level-2-260C-1 YEAR	-40 to 125	ISO7231M	Samples

(1) The marketing status values are defined as follows:

ACTIVE: Product device recommended for new designs.

LIFEBUY: TI has announced that the device will be discontinued, and a lifetime-buy period is in effect.

NRND: Not recommended for new designs. Device is in production to support existing customers, but TI does not recommend using this part in a new design.

PREVIEW: Device has been announced but is not in production. Samples may or may not be available.

OBSELETE: TI has discontinued the production of the device.

(2) **RoHS:** TI defines "RoHS" to mean semiconductor products that are compliant with the current EU RoHS requirements for all 10 RoHS substances, including the requirement that RoHS substance do not exceed 0.1% by weight in homogeneous materials. Where designed to be soldered at high temperatures, "RoHS" products are suitable for use in specified lead-free processes. TI may reference these types of products as "Pb-Free".

RoHS Exempt: TI defines "RoHS Exempt" to mean products that contain lead but are compliant with EU RoHS pursuant to a specific EU RoHS exemption.

Green: TI defines "Green" to mean the content of Chlorine (Cl) and Bromine (Br) based flame retardants meet JS709B low halogen requirements of <=1000ppm threshold. Antimony trioxide based flame retardants must also meet the <=1000ppm threshold requirement.

(3) MSL, Peak Temp. - The Moisture Sensitivity Level rating according to the JEDEC industry standard classifications, and peak solder temperature.

(4) There may be additional marking, which relates to the logo, the lot trace code information, or the environmental category on the device.

(5) Multiple Device Markings will be inside parentheses. Only one Device Marking contained in parentheses and separated by a "~" will appear on a device. If a line is indented then it is a continuation of the previous line and the two combined represent the entire Device Marking for that device.

(6) Lead finish/Ball material - Orderable Devices may have multiple material finish options. Finish options are separated by a vertical ruled line. Lead finish/Ball material values may wrap to two lines if the finish value exceeds the maximum column width.

Important Information and Disclaimer:The information provided on this page represents TI's knowledge and belief as of the date that it is provided. TI bases its knowledge and belief on information provided by third parties, and makes no representation or warranty as to the accuracy of such information. Efforts are underway to better integrate information from third parties. TI has taken and continues to take reasonable steps to provide representative and accurate information but may not have conducted destructive testing or chemical analysis on incoming materials and chemicals. TI and TI suppliers consider certain information to be proprietary, and thus CAS numbers and other limited information may not be available for release.

In no event shall TI's liability arising out of such information exceed the total purchase price of the TI part(s) at issue in this document sold by TI to Customer on an annual basis.

OTHER QUALIFIED VERSIONS OF ISO7231C :

- Automotive : [ISO7231C-Q1](#)

NOTE: Qualified Version Definitions:

- Automotive - Q100 devices qualified for high-reliability automotive applications targeting zero defects

TAPE AND REEL INFORMATION

QUADRANT ASSIGNMENTS FOR PIN 1 ORIENTATION IN TAPE



*All dimensions are nominal

Device	Package Type	Package Drawing	Pins	SPQ	Reel Diameter (mm)	Reel Width W1 (mm)	A0 (mm)	B0 (mm)	K0 (mm)	P1 (mm)	W (mm)	Pin1 Quadrant
ISO7230CDWR	SOIC	DW	16	2000	330.0	16.4	10.75	10.7	2.7	12.0	16.0	Q1
ISO7230MDWR	SOIC	DW	16	2000	330.0	16.4	10.75	10.7	2.7	12.0	16.0	Q1
ISO7231CDWR	SOIC	DW	16	2000	330.0	16.4	10.75	10.7	2.7	12.0	16.0	Q1
ISO7231MDWR	SOIC	DW	16	2000	330.0	16.4	10.75	10.7	2.7	12.0	16.0	Q1

TAPE AND REEL BOX DIMENSIONS

*All dimensions are nominal

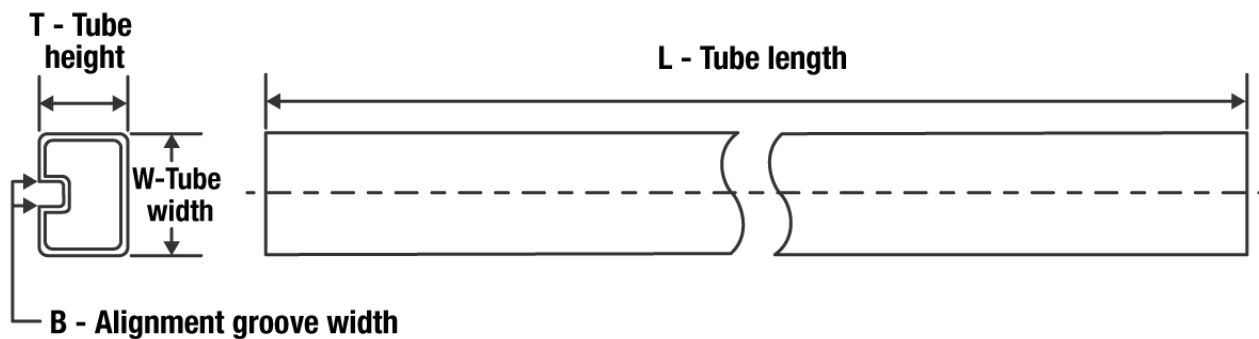
Device	Package Type	Package Drawing	Pins	SPQ	Length (mm)	Width (mm)	Height (mm)
ISO7230CDWR	SOIC	DW	16	2000	350.0	350.0	43.0
ISO7230MDWR	SOIC	DW	16	2000	350.0	350.0	43.0
ISO7231CDWR	SOIC	DW	16	2000	350.0	350.0	43.0
ISO7231MDWR	SOIC	DW	16	2000	350.0	350.0	43.0

TUBE

*All dimensions are nominal

Device	Package Name	Package Type	Pins	SPQ	L (mm)	W (mm)	T (μm)	B (mm)
ISO7230CDW	DW	SOIC	16	40	506.98	12.7	4826	6.6
ISO7230CDWG4	DW	SOIC	16	40	506.98	12.7	4826	6.6
ISO7230MDW	DW	SOIC	16	40	506.98	12.7	4826	6.6
ISO7231CDW	DW	SOIC	16	40	506.98	12.7	4826	6.6
ISO7231MDW	DW	SOIC	16	40	506.98	12.7	4826	6.6

IMPORTANT NOTICE AND DISCLAIMER

TI PROVIDES TECHNICAL AND RELIABILITY DATA (INCLUDING DATA SHEETS), DESIGN RESOURCES (INCLUDING REFERENCE DESIGNS), APPLICATION OR OTHER DESIGN ADVICE, WEB TOOLS, SAFETY INFORMATION, AND OTHER RESOURCES "AS IS" AND WITH ALL FAULTS, AND DISCLAIMS ALL WARRANTIES, EXPRESS AND IMPLIED, INCLUDING WITHOUT LIMITATION ANY IMPLIED WARRANTIES OF MERCHANTABILITY, FITNESS FOR A PARTICULAR PURPOSE OR NON-INFRINGEMENT OF THIRD PARTY INTELLECTUAL PROPERTY RIGHTS.

These resources are intended for skilled developers designing with TI products. You are solely responsible for (1) selecting the appropriate TI products for your application, (2) designing, validating and testing your application, and (3) ensuring your application meets applicable standards, and any other safety, security, regulatory or other requirements.

These resources are subject to change without notice. TI grants you permission to use these resources only for development of an application that uses the TI products described in the resource. Other reproduction and display of these resources is prohibited. No license is granted to any other TI intellectual property right or to any third party intellectual property right. TI disclaims responsibility for, and you will fully indemnify TI and its representatives against, any claims, damages, costs, losses, and liabilities arising out of your use of these resources.

TI's products are provided subject to [TI's Terms of Sale](#) or other applicable terms available either on ti.com or provided in conjunction with such TI products. TI's provision of these resources does not expand or otherwise alter TI's applicable warranties or warranty disclaimers for TI products.

TI objects to and rejects any additional or different terms you may have proposed.

Mailing Address: Texas Instruments, Post Office Box 655303, Dallas, Texas 75265
Copyright © 2022, Texas Instruments Incorporated