

# LP87524B/J/P-Q1 适用于 AWR 和 IWR MMIC 的四 4MHz 降压转换器

## 1 特性

- 符合汽车应用 要求
- 具有符合 AEC-Q100 标准的下列结果：
  - 器件温度 1 级：-40°C 至 +125°C 的环境运行温度范围
- 输入电压：2.8V 至 5.5V
- 输出电压：0.6V 至 3.36V
- 四个高效降压直流/直流转换器内核：
  - 总输出电流高达 10A
  - 输出电压转换率 3.8mV/μs
- 4MHz 开关频率
- 扩频模式和相位交错
- 可配置通用 I/O (GPIO)
- I<sup>2</sup>C 兼容接口，支持标准 (100kHz)、快速 (400kHz)、快速+ (1MHz) 和高速 (3.4MHz) 四种模式
- 具有可编程屏蔽的中断功能
- 可编程电源正常信号 (PGOOD)
- 输出短路和过载保护
- 过热警告和保护
- 过压保护 (OVP) 和欠压锁定 (UVLO)

## 2 应用

汽车信息娱乐系统、仪表组、雷达和摄像头电源应用

## 3 说明

LP87524B/J/P-Q1 专为满足各种汽车电源应用中最新处理器和平台的电源管理要求而设计。该器件包含四个降压直流/直流转换器内核，这些内核配置为 4 个单相输出。该器件由 I<sup>2</sup>C 兼容串行接口和使能信号进行控制。

自动 PFM/PWM (AUTO 模式) 操作可在较宽输出电流范围内最大限度地提高效率。LP87524B/J/P-Q1 支持远程电压感应，可补偿稳压器输出与负载点 (POL) 之间的 IR 压降，从而提高输出电压的精度。此外，可以强制开关时钟进入 PWM 模式以及将其与外部时钟同步，从而最大限度地降低干扰。

LP87524B/J/P-Q1 器件支持在不添加外部电流感应电阻器的情况下进行负载电流测量。此外，LP87524B/J/P-Q1 还支持与使能信号同步的可编程启动和关断延迟与时序。这些序列可能还包括用于控制外部稳压器、负载开关和处理器复位的 GPIO 信号。在启动和电压变化期间，器件会对输出转换率进行控制，从而最大限度地减小输出电压过冲和浪涌电流。

器件信息(1)

器件型号	封装	封装尺寸 (标称值)
LP87524B-Q1	VQFN-HR (26)	4.50mm × 4.00mm
LP87524J-Q1		
LP87524P-Q1		

(1) 如需了解所有可用封装，请参阅数据表末尾的可订购产品附录。

简化原理图

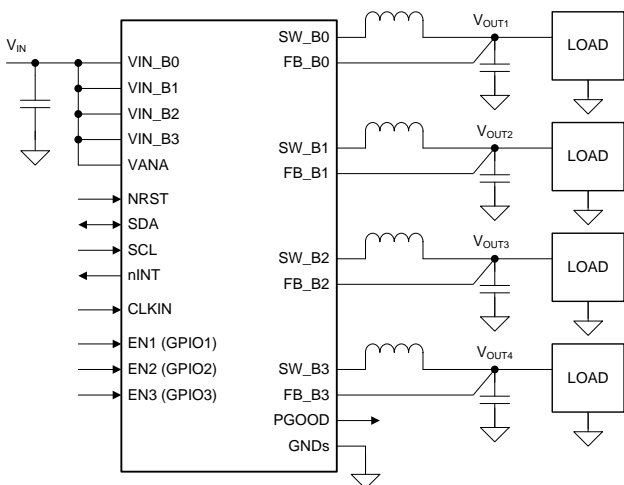

Copyright © 2017, Texas Instruments Incorporated

效率与输出电流间的关系

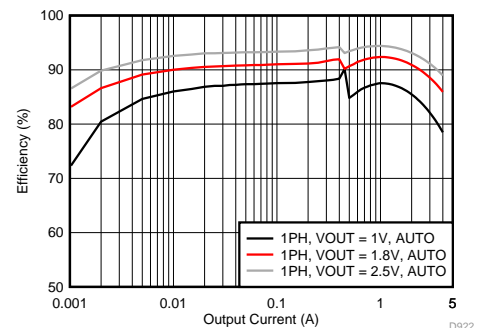

D922



## 目录

<b>1</b>	特性 .....	<b>1</b>	7.5	Programming.....	<b>32</b>
<b>2</b>	应用 .....	<b>1</b>	7.6	Register Maps .....	<b>35</b>
<b>3</b>	说明 .....	<b>1</b>	<b>8</b>	<b>Application and Implementation .....</b>	<b>57</b>
<b>4</b>	修订历史记录 .....	<b>2</b>	8.1	Application Information.....	<b>57</b>
<b>5</b>	<b>Pin Configuration and Functions .....</b>	<b>3</b>	8.2	Typical Application .....	<b>57</b>
<b>6</b>	<b>Specifications.....</b>	<b>5</b>	<b>9</b>	<b>Power Supply Recommendations.....</b>	<b>63</b>
6.1	Absolute Maximum Ratings .....	<b>5</b>	<b>10</b>	<b>Layout.....</b>	<b>64</b>
6.2	ESD Ratings .....	<b>5</b>	10.1	Layout Guidelines .....	<b>64</b>
6.3	Recommended Operating Conditions.....	<b>5</b>	10.2	Layout Example .....	<b>65</b>
6.4	Thermal Information .....	<b>6</b>	<b>11</b>	<b>器件和文档支持 .....</b>	<b>66</b>
6.5	Electrical Characteristics.....	<b>6</b>	11.1	器件支持.....	<b>66</b>
6.6	I2C Serial Bus Timing Requirements.....	<b>11</b>	11.2	接收文档更新通知 .....	<b>66</b>
6.7	Typical Characteristics.....	<b>13</b>	11.3	社区资源 .....	<b>66</b>
<b>7</b>	<b>Detailed Description .....</b>	<b>14</b>	11.4	商标 .....	<b>66</b>
7.1	Overview .....	<b>14</b>	11.5	静电放电警告.....	<b>66</b>
7.2	Functional Block Diagram .....	<b>15</b>	11.6	术语表 .....	<b>66</b>
7.3	Feature Descriptions.....	<b>15</b>	<b>12</b>	<b>机械、封装和可订购信息.....</b>	<b>67</b>
7.4	Device Functional Modes.....	<b>30</b>			

## 4 修订历史记录

注：之前版本的页码可能与当前版本有所不同。

<b>Changes from Revision A (December 2017) to Revision B</b>	<b>Page</b>
• 已添加 在 SNVSAW2 数据表中添加了 LP87524P-Q1 GPN.....	<b>1</b>

<b>Changes from Original (April 2017) to Revision A</b>	<b>Page</b>
• 已添加 在 SNVSAW2 数据表中添加了 LP87524J-Q1 GPN .....	<b>1</b>

## 5 Pin Configuration and Functions

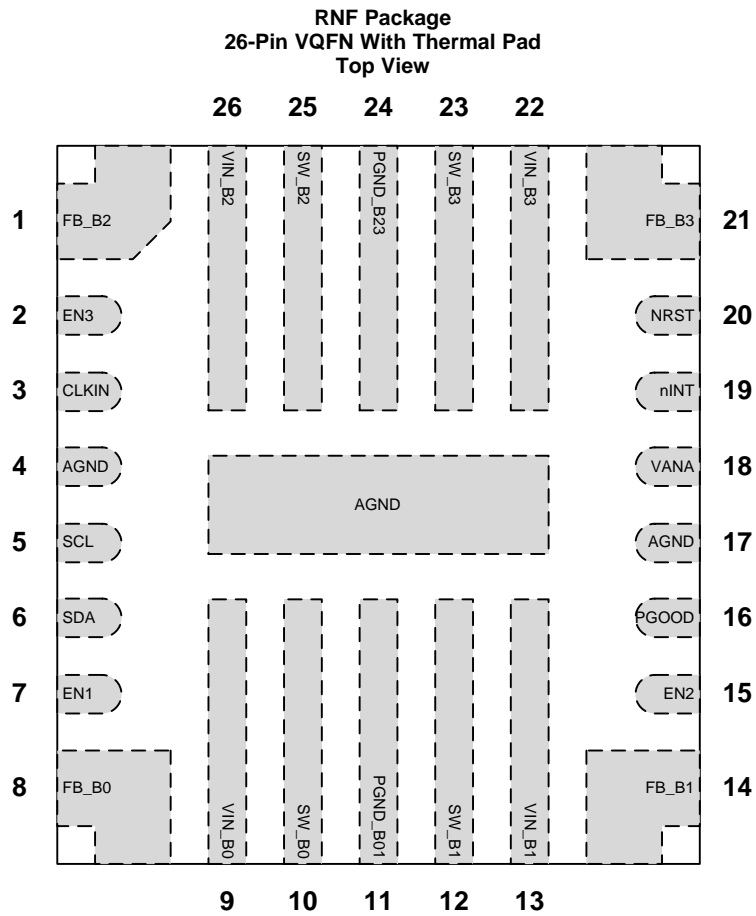

### Pin Functions

PIN		TYPE	DESCRIPTION
NUMBER	NAME		
1	FB_B2	A	Output voltage feedback (positive) for Buck2.
2	EN3	D/I/O	Programmable enable signal for buck regulators (can be also configured to select between two buck output voltage levels). Alternative function is GPIO3.
3	CLKIN	D/I	External clock input. Connect to ground if external clock is not used.
4, 17, Thermal Pad	AGND	G	Ground
5	SCL	D/I	Serial interface clock input for I2C access. Connect a pullup resistor.
6	SDA	D/I/O	Serial interface data input and output for I2C access. Connect a pullup resistor.
7	EN1	D/I/O	Programmable Enable signal for buck regulators (can be also configured to select between two buck output voltage levels). Alternative function is GPIO1.
8	FB_B0	A	Output voltage feedback (positive) for Buck0
9	VIN_B0	P	Input for Buck0. The separate power pins VIN_Bx are not connected together internally - VIN_Bx pins must be connected together in the application and be locally bypassed.
10	SW_B0	A	Buck0 switch node
11	PGND_B01	G	Power ground for Buck0 and Buck1
12	SW_B1	A	Buck1 switch node
13	VIN_B1	P	Input for Buck1. The separate power pins VIN_Bx are not connected together internally – VIN_Bx pins must be connected together in the application and be locally bypassed.
14	FB_B1	A	Output voltage feedback (positive) for Buck1.
15	EN2	D/I/O	Programmable enable signal for Buck regulators (can be also configured to select between two buck output voltage levels). Alternative function is GPIO2.
16	PGOOD	D/O	Power Good indication signal
18	VANA	P	Supply voltage for analog and digital blocks. Must be connected to same node as with VIN_Bx.
19	nINT	D/O	Open-drain interrupt output, active LOW
20	NRST	D/I	Reset signal for the device.
21	FB_B3	A	Output voltage feedback (positive) for Buck3.
22	VIN_B3	P	Input for Buck3. The separate power pins VIN_Bx are not connected together internally – VIN_Bx pins must be connected together in the application and be locally bypassed.
23	SW_B3	A	Buck3 switch node
24	PGND_B23	G	Power Ground for Buck2 and Buck3
25	SW_B2	A	Buck2 switch node
26	VIN_B2	P	Input for Buck2. The separate power pins VIN_Bx are not connected together internally – VIN_Bx pins must be connected together in the application and be locally bypassed.

A: Analog Pin, D: Digital Pin, G: Ground Pin, P: Power Pin, I: Input Pin, O: Output Pin

## 6 Specifications

### 6.1 Absolute Maximum Ratings

Over operating free-air temperature range (unless otherwise noted)<sup>(1)</sup> <sup>(2)</sup>

		MIN	MAX	UNIT
Voltage on power connections	VIN_Bx, VANA	-0.3	6	V
Voltage on buck switch nodes	SW_Bx	-0.3	(VIN_Bx + 0.3 V) with 6 V maximum	V
Voltage on buck voltage sense nodes	FB_Bx	-0.3	(VANA + 0.3 V) with 6 V maximum	V
Voltage on NRST input	NRST	-0.3	6	V
Voltage on logic pins (input or output pins)	SDA, SCL, nINT, CLKIN	-0.3	6	V
Voltage on logic pins (input or output pins)	EN1 (GPIO1), EN2 (GPIO2), EN3 (GPIO3), PGOOD	-0.3	(VANA + 0.3 V) with 6 V maximum	V
Junction temperature, T <sub>J-MAX</sub>		-40	150	°C
Storage temperature, T <sub>stg</sub>		-65	150	°C
Maximum lead temperature (soldering, 10 sec.)			260	°C

- (1) Stresses beyond those listed under *Absolute Maximum Ratings* may cause permanent damage to the device. These are stress ratings only, which do not imply functional operation of the device at these or any other conditions beyond those indicated under *Recommended Operating Conditions*. Exposure to absolute-maximum-rated conditions for extended periods may affect device reliability.
- (2) All voltage values are with respect to network ground.

### 6.2 ESD Ratings

		VALUE	UNIT	
V <sub>(ESD)</sub>	Electrostatic discharge	Human-body model (HBM), per AEC Q100-002 <sup>(1)</sup>	±2000	
		Charged-device model (CDM), per AEC Q100-011	All pins	±500
			Corner pins (1, 8, 14 and 21)	±750

- (1) AEC Q100-002 indicates that HBM stressing shall be in accordance with the ANSI/ESDA/JEDEC JS-001 specification.

### 6.3 Recommended Operating Conditions

Over operating free-air temperature range (unless otherwise noted)

		MIN	MAX	UNIT
<b>INPUT VOLTAGE</b>				
Voltage on power connections	VIN_Bx, VANA	2.8	5.5	V
Voltage on NRST	NRST	1.65	VANA with 5.5 V maximum	V
Voltage on logic pins	nINT, CLKIN	1.65	5.5	V
Voltage on logic pins (input or output pins)	ENx, PGOOD	0	VANA with 5.5 V maximum	V
Voltage on I2C interface, standard (100 kHz), fast (400 kHz), fast+ (1 MHz), and high-speed (3.4 MHz) modes	SCL, SDA	1.65	1.95	V
Voltage on I2C interface, standard (100 kHz), fast (400 kHz), and fast+ (1 MHz) modes		3.1	VANA with 3.6 V maximum	V
<b>TEMPERATURE</b>				
Junction temperature, T <sub>J</sub>		-40	140	°C
Ambient temperature, T <sub>A</sub>		-40	125	°C

## 6.4 Thermal Information

THERMAL METRIC <sup>(1)</sup>		LP875xx-Q1	UNIT
		RNF (VQFN)	
		26 PINS	
R <sub>θJA</sub>	Junction-to-ambient thermal resistance	34.6	°C/W
R <sub>θJC(top)</sub>	Junction-to-case (top) thermal resistance	16.5	°C/W
R <sub>θJB</sub>	Junction-to-board thermal resistance	4.7	°C/W
ψ <sub>JT</sub>	Junction-to-top characterization parameter	0.6	°C/W
ψ <sub>JB</sub>	Junction-to-board characterization parameter	4.7	°C/W
R <sub>θJC(bot)</sub>	Junction-to-case (bottom) thermal resistance	1.4	°C/W

(1) For more information about traditional and new thermal metrics, see the [Semiconductor and IC Package Thermal Metrics](#) application report.

## 6.5 Electrical Characteristics

Limits apply over the junction temperature range  $-40^{\circ}\text{C} \leq T_J \leq +140^{\circ}\text{C}$ ,  $C_{POL} = 22 \mu\text{F}$  / phase, specified  $V_{VANA}$ ,  $V_{VIN\_Bx}$ ,  $V_{NRST}$ ,  $V_{VOUT\_Bx}$  and  $I_{OUT}$  range, unless otherwise noted. Typical values are at  $T_J = 25^{\circ}\text{C}$ ,  $V_{VANA} = V_{VIN\_Bx} = 3.7 \text{ V}$ , and  $V_{OUT} = 1 \text{ V}$ , unless otherwise noted.<sup>(1) (2)</sup>

PARAMETER	TEST CONDITIONS	MIN	TYP	MAX	UNIT	
<b>EXTERNAL COMPONENTS</b>						
C <sub>IN</sub>	Input filtering capacitance Connected from VIN_Bx to PGND_Bx	1.9	10		μF	
C <sub>OUT</sub>	Output filtering Capacitance, local Capacitance per phase	10	22		μF	
C <sub>POL</sub>	Point-of-Load (POL) capacitance Optional POL capacitance per phase		22		μF	
C <sub>OUT-TOTAL</sub>	Output capacitance, total (local and POL) Total output capacitance, 1-phase output			100	μF	
ESR <sub>C</sub>	Input and output capacitor ESR [1-10] MHz		2	10	mΩ	
L	Inductor Inductance of the inductor		0.47		μH	
		-30%		30%		
DCR <sub>L</sub>	Inductor DCR		25		mΩ	
<b>BUCK REGULATOR</b>						
V <sub>VIN_Bx</sub>	Input voltage range	2.8	3.7	5.5	V	
V <sub>VOUT_Bx</sub>	Output voltage	Programmable voltage range, $2.8 \text{ V} \leq V_{VIN\_Bx} \leq 4 \text{ V}$	0.6		3.36	V
		Programmable voltage range, $2.8 \text{ V} \leq V_{VIN\_Bx} \leq 5.5 \text{ V}$	1.0		3.36	V
		Step size, $0.6 \text{ V} \leq V_{OUT} < 0.73 \text{ V}$		10		mV
		Step size, $0.73 \text{ V} \leq V_{OUT} < 1.4 \text{ V}$		5		mV
		Step size, $1.4 \text{ V} \leq V_{OUT} \leq 3.36 \text{ V}$		20		mV
I <sub>OUT</sub>	Output current, LP87524B/J	Buck0, Buck1			1.5 <sup>(3)</sup>	A
		Buck2: $V_{IN} \geq 3 \text{ V}$			4 <sup>(3)</sup>	
		Buck2: $2.8 \text{ V} \leq V_{IN} < 3 \text{ V}$			3 <sup>(3)</sup>	
		Buck3			2.5 <sup>(3)</sup>	
I <sub>OUT</sub>	Output current, LP87524P	Buck0, Buck2			3 <sup>(3)</sup>	A
		Buck1			1.5 <sup>(3)</sup>	
		Buck3			2.5 <sup>(3)</sup>	

(1) All voltage values are with respect to network ground.

(2) Minimum (Min) and Maximum (Max) limits are specified by design, test, or statistical analysis. Typical (Typ) numbers are not verified, but do represent the most likely norm.

(3) The maximum output current can be limited by the forward current limit  $I_{LIM\_FWD}$  and by the junction temperature. The power dissipation inside the die depends on the length of the current pulse and efficiency and the junction temperature may increase to thermal shutdown level if the board and ambient temperatures are high.

## Electrical Characteristics (continued)

Limits apply over the junction temperature range  $-40^{\circ}\text{C} \leq T_J \leq +140^{\circ}\text{C}$ ,  $C_{POL} = 22 \mu\text{F}$  / phase, specified  $V_{VANA}$ ,  $V_{VIN\_Bx}$ ,  $V_{NRST}$ ,  $V_{VOUT\_Bx}$  and  $I_{OUT}$  range, unless otherwise noted. Typical values are at  $T_J = 25^{\circ}\text{C}$ ,  $V_{VANA} = V_{VIN\_Bx} = 3.7 \text{ V}$ , and  $V_{OUT} = 1 \text{ V}$ , unless otherwise noted.<sup>(1) (2)</sup>

PARAMETER	TEST CONDITIONS	MIN	TYP	MAX	UNIT	
Input and output voltage difference	Minimum voltage between $V_{IN\_x}$ and $V_{OUT}$ to fulfill the electrical characteristics	0.5			V	
$V_{VOUT\_DC}$	DC output voltage accuracy, includes voltage reference, DC load and line regulations, process and temperature	$V_{OUT} < 1 \text{ V}$ , PWM mode		20	mV	
		$V_{OUT} \geq 1 \text{ V}$ , PWM mode	-2%	2%		
		$V_{OUT} < 1 \text{ V}$ , PFM mode	-20		40	mV
		$V_{OUT} \geq 1 \text{ V}$ , PFM mode	-2%	2% + 20 mV		
Ripple voltage	PWM mode, $ESR_C < 2 \text{ m}\Omega$ , $L = 0.47 \mu\text{H}$		4		mV <sub>p-p</sub>	
	PFM mode, $L = 0.47 \mu\text{H}$		14			
$DC_{LNR}$	DC line regulation	$I_{OUT} = I_{OUT(max)}$	0.1		%/V	
$DC_{LDR}$	DC load regulation in PWM mode	$V_{OUT} = 1 \text{ V}$ , $I_{OUT}$ from 0 to $I_{OUT(max)}$	0.8%			
$T_{LDSR}$	Transient load step response	$I_{OUT} = 0 \text{ A}$ to $2 \text{ A}$ , $T_R = T_F = 10 \mu\text{s}$ , PWM mode, $C_{OUT} = 22 \mu\text{F}$ , $L = 0.47 \mu\text{H}$ , $C_{POL} = 22 \mu\text{F}$	-3%		3%	mV
		$I_{OUT} = 0.1 \text{ A}$ to $2 \text{ A}$ , $T_R = T_F = 1 \mu\text{s}$ , PWM mode, $C_{OUT} = 22 \mu\text{F}$ , $L = 0.47 \mu\text{H}$ , $C_{POL} = 22 \mu\text{F}$		$\pm 40$		
$T_{LNSR}$	Transient line response	$V_{VIN\_Bx}$ stepping $3 \text{ V} \leftrightarrow 3.5 \text{ V}$ , $T_R = T_F = 10 \mu\text{s}$ , $I_{OUT} = I_{OUT(max)}$		$\pm 5$	mV	
$I_{LIM \text{ FWD}}$	Forward current limit (peak for every switching cycle), LP87524B/J	Buck0, Buck1: $V_{VIN\_Bx} \geq 3 \text{ V}$	2.3	2.7	3.0	A
		Buck0, Buck1: $2.8 \text{ V} \leq V_{VIN\_Bx} < 3 \text{ V}$	2.0	2.7	3.0	
		Buck2: $V_{VIN\_Bx} \geq 3 \text{ V}$	4.7	5.4	6.0	
		Buck2: $2.8 \text{ V} \leq V_{VIN\_Bx} < 3 \text{ V}$	4.0	5.4	6.0	
		Buck3: $V_{VIN\_Bx} \geq 3 \text{ V}$	4.2	4.8	5.4	
		Buck3: $2.8 \text{ V} \leq V_{VIN\_Bx} < 3 \text{ V}$	3.6	4.8	5.4	
$I_{LIM \text{ FWD}}$	Forward current limit (peak for every switching cycle), LP87524P	Buck0, Buck2: $V_{VIN\_Bx} \geq 3 \text{ V}$	3.8	4.3	4.8	A
		Buck0, Buck2: $2.8 \text{ V} \leq V_{VIN\_Bx} < 3 \text{ V}$	3.2	4.3	4.8	
		Buck1: $V_{VIN\_Bx} \geq 3 \text{ V}$	2.3	2.7	3.0	
		Buck1: $2.8 \text{ V} \leq V_{VIN\_Bx} < 3 \text{ V}$	2.0	2.7	3.0	
		Buck3: $V_{VIN\_Bx} \geq 3 \text{ V}$	4.2	4.8	5.4	
		Buck3: $2.8 \text{ V} \leq V_{VIN\_Bx} < 3 \text{ V}$	3.6	4.8	5.4	
$I_{LIM \text{ NEG}}$	Negative current limit / phase (peak for every switching cycle)	1.6	2	2.4	A	
$R_{DS(ON) \text{ HS FET}}$	On-resistance, high-side FET	Each phase, between $V_{IN\_Bx}$ and $SW\_Bx$ pins ( $I = 1 \text{ A}$ )	29	65	m $\Omega$	
$R_{DS(ON) \text{ LS FET}}$	On-resistance, low-side FET	Each phase, between $SW\_Bx$ and $PGND\_Bx$ pins ( $I = 1 \text{ A}$ )	17	35	m $\Omega$	
$f_{SW}$	Switching frequency, PWM mode	$V_{OUT} > 0.8$	3.6	4	4.4	MHz
		$0.6 < V_{OUT} \leq 0.8$	2.7	3	3.3	
		$V_{OUT} = 0.6$	1.8	2	2.2	
	Start-up time (soft start)	From $ENx$ to $V_{OUT} = 0.35 \text{ V}$ (slew-rate control begins), $C_{OUT\_TOTAL} = 44 \mu\text{F}$ / phase		200	$\mu\text{s}$	
	Output voltage slew-rate <sup>(4)</sup>		3.23	3.8	4.4	mV/ $\mu\text{s}$

(4) Output capacitance, forward and negative current limits and load current may limit the maximum and minimum slew rates.

## Electrical Characteristics (continued)

Limits apply over the junction temperature range  $-40^{\circ}\text{C} \leq T_J \leq +140^{\circ}\text{C}$ ,  $C_{POL} = 22 \mu\text{F}$  / phase, specified  $V_{VANA}$ ,  $V_{VIN\_Bx}$ ,  $V_{NRST}$ ,  $V_{VOUT\_Bx}$  and  $I_{OUT}$  range, unless otherwise noted. Typical values are at  $T_J = 25^{\circ}\text{C}$ ,  $V_{VANA} = V_{VIN\_Bx} = 3.7 \text{ V}$ , and  $V_{OUT} = 1 \text{ V}$ , unless otherwise noted.<sup>(1) (2)</sup>

PARAMETER		TEST CONDITIONS	MIN	TYP	MAX	UNIT
$I_{PFM-PWM}$	PFM-to-PWM - current threshold <sup>(5)</sup>			600		mA
$I_{PWM-PFM}$	PWM-to-PFM - current threshold <sup>(5)</sup>			200		mA
	Output pulldown resistance	Regulator disabled	160	230	300	$\Omega$
	Output voltage monitoring for PGOOD pin	Overvoltage monitoring (compared to DC output voltage level, $V_{VOUT\_DC}$ )	39	50	64	mV
		Undervoltage monitoring (compared to DC output voltage level, $V_{VOUT\_DC}$ )	-53	-40	-29	
		Debounce time during regulator enable PGOOD_SET_DELAY = 0	4		10	$\mu\text{s}$
		Debounce time during regulator enable PGOOD_SET_DELAY = 1	10	11	13	ms
		Deglitch time during operation and after voltage change	4		10	$\mu\text{s}$
Powergood threshold for interrupt BUCKx_PG_INT, difference from final voltage	Rising ramp voltage, enable or voltage change		-20	-14	-8	mV
	Falling ramp voltage, voltage change		8	14	20	
Powergood threshold for status bit BUCKx_PG_STAT	During operation, status signal is forced to '0' during voltage change		-20	-14	-8	mV
<b>EXTERNAL CLOCK AND PLL</b>						
External input clock	Nominal frequency		1		24	MHz
	Nominal frequency step size			1		
	Required accuracy from nominal frequency		-30%		10%	
External clock detection	Delay for missing clock detection				1.8	$\mu\text{s}$
	Delay and debounce for clock detection				20	
Clock change delay (internal to external)	Delay from valid clock detection to use of external clock			600		$\mu\text{s}$
PLL output clock jitter	Cycle to cycle			300		ps, p-p
<b>PROTECTION FUNCTIONS</b>						
Thermal warning	Temperature rising, TDIE_WARN_LEVEL = 0		115	125	135	$^{\circ}\text{C}$
	Temperature rising, TDIE_WARN_LEVEL = 1		127	137	147	
	Hysteresis			20		
Thermal shutdown	Temperature rising		140	150	160	$^{\circ}\text{C}$
	Hysteresis			20		
$V_{ANA\_OVP}$ VANA overvoltage	Voltage rising		5.6	5.8	6.1	V
	Voltage falling		5.45	5.73	5.96	
	Hysteresis		40			mV
$V_{ANA\_UVLO}$ VANA undervoltage lockout	Voltage rising		2.51	2.63	2.75	V
	Voltage falling		2.5	2.6	2.7	
<b>LOAD CURRENT MEASUREMENT</b>						

(5) The final PFM-to-PWM and PWM-to-PFM switchover current varies slightly and is dependent on the output voltage, input voltage, and the inductor current level.

## Electrical Characteristics (continued)

Limits apply over the junction temperature range  $-40^{\circ}\text{C} \leq T_J \leq +140^{\circ}\text{C}$ ,  $C_{POL} = 22 \mu\text{F}$  / phase, specified  $V_{VANA}$ ,  $V_{VIN\_Bx}$ ,  $V_{NRST}$ ,  $V_{VOUT\_Bx}$  and  $I_{OUT}$  range, unless otherwise noted. Typical values are at  $T_J = 25^{\circ}\text{C}$ ,  $V_{VANA} = V_{VIN\_Bx} = 3.7 \text{ V}$ , and  $V_{OUT} = 1 \text{ V}$ , unless otherwise noted.<sup>(1) (2)</sup>

PARAMETER	TEST CONDITIONS	MIN	TYP	MAX	UNIT
Current measurement range	Output current for maximum code			20.47	A
Resolution	LSB		20		mA
Measurement accuracy	$I_{OUT} > 1 \text{ A}$		<10%		
Measurement time	PFM mode (automatically changing to PWM mode for the measurement)		45		$\mu\text{s}$
	PWM mode		4		
<b>CURRENT CONSUMPTION</b>					
Shutdown current consumption	From VANA and VIN_Bx pins: NRST = 0 V, VANA = VIN_Bx = 3.7 V		1.4		$\mu\text{A}$
Standby current consumption, regulators disabled	From VANA and VIN_Bx pins: NRST = 1.8 V, VANA = VIN_Bx = 3.7 V		6.7		
Active current consumption in PFM mode, one regulator enabled, internal RC oscillator, PGOOD monitoring enabled	From VANA and VIN_Bx pins: NRST = 1.8 V, VANA = VIN_Bx = 3.7 V, $I_{OUT} = 0 \text{ mA}$ , not switching		57		$\mu\text{A}$
Active current consumption during PWM operation, per phase			19		mA
PLL and clock detector current consumption	Additional current consumption when internal RC oscillator, clock detector and PLL are enabled		2		mA
<b>DIGITAL INPUT SIGNALS NRST, EN1, EN2, EN3, EN4, SCL, SDA, GPIO1, GPIO2, GPIO3, CLKIN</b>					
$V_{IL}$	Input low level			0.4	V
$V_{IH}$	Input high level	1.2			
$V_{HYS}$	Hysteresis of Schmitt Trigger inputs	10	77	200	mV
	ENx pulldown resistance	ENx_PD = 1	500		k $\Omega$
	NRST pulldown resistance	Always present	650	1150	
<b>DIGITAL OUTPUT SIGNALS nINT</b>					
$V_{OL}$	Output low level	$I_{SOURCE} = 2 \text{ mA}$		0.4	V
$R_P$	External pullup resistor	To VIO supply	10		k $\Omega$
<b>DIGITAL OUTPUT SIGNALS SDA</b>					
$V_{OL}$	Output low level	$I_{SOURCE} = 10 \text{ mA}$		0.4	V
<b>DIGITAL OUTPUT SIGNALS PGOOD, GPIO1, GPIO2, GPIO3</b>					
$V_{OL}$	Output low level	$I_{SOURCE} = 2 \text{ mA}$		0.4	V
$V_{OH}$	Output high level, configured to push-pull	$I_{SINK} = 2 \text{ mA}$	$V_{VANA} - 0.4$	$V_{VANA}$	V
$V_{PU}$	Supply voltage for external pull-up resistor, configured to open-drain			$V_{VANA}$	V
$R_{PU}$	External pullup resistor, configured to open-drain		10		k $\Omega$
<b>ALL DIGITAL INPUTS</b>					

### Electrical Characteristics (continued)

Limits apply over the junction temperature range  $-40^{\circ}\text{C} \leq T_J \leq +140^{\circ}\text{C}$ ,  $C_{POL} = 22 \mu\text{F}$  / phase, specified  $V_{VANA}$ ,  $V_{VIN\_Bx}$ ,  $V_{NRST}$ ,  $V_{VOUT\_Bx}$  and  $I_{OUT}$  range, unless otherwise noted. Typical values are at  $T_J = 25^{\circ}\text{C}$ ,  $V_{VANA} = V_{VIN\_Bx} = 3.7 \text{ V}$ , and  $V_{OUT} = 1 \text{ V}$ , unless otherwise noted.<sup>(1) (2)</sup>

PARAMETER		TEST CONDITIONS	MIN	TYP	MAX	UNIT
$I_{LEAK}$	Input current	All logic inputs over pin voltage range (except NRST)	-1		1	$\mu\text{A}$

## 6.6 I2C Serial Bus Timing Requirements

These specifications are ensured by design. Unless otherwise noted,  $V_{IN\_Bx} = 3.7\text{ V}$ .

		MIN	MAX	UNIT	
$f_{SCL}$	Serial clock frequency	Standard mode	100	kHz	
		Fast mode	400		
		Fast mode+	1	MHz	
		High-speed mode, $C_b = 100\text{ pF}$	3.4		
		High-speed mode, $C_b = 400\text{ pF}$	1.7		
$t_{LOW}$	SCL low time	Standard mode	4.7	$\mu\text{s}$	
		Fast mode	1.3		
		Fast mode+	0.5		
		High-speed mode, $C_b = 100\text{ pF}$	160	ns	
		High-speed mode, $C_b = 400\text{ pF}$	320		
$t_{HIGH}$	SCL high time	Standard mode	4	$\mu\text{s}$	
		Fast mode	0.6		
		Fast mode+	0.26		
		High-speed mode, $C_b = 100\text{ pF}$	60	ns	
		High-speed mode, $C_b = 400\text{ pF}$	120		
$t_{SU;DAT}$	Data setup time	Standard mode	250	ns	
		Fast mode	100		
		Fast mode+	50		
		High-speed mode	10		
$t_{HD;DAT}$	Data hold time	Standard mode	10	3450	ns
		Fast mode	10	900	
		Fast mode+	10		
		High-speed mode, $C_b = 100\text{ pF}$	10	70	ns
		High-speed mode, $C_b = 400\text{ pF}$	10	150	
$t_{SU;STA}$	Setup time for a start or a repeated start condition	Standard mode	4.7	$\mu\text{s}$	
		Fast mode	0.6		
		Fast mode+	0.26	ns	
		High-speed mode	160		
$t_{HD;STA}$	Hold time for a start or a repeated start condition	Standard mode	4.0	$\mu\text{s}$	
		Fast mode	0.6		
		Fast mode+	0.26	ns	
		High-speed mode	160		
$t_{BUF}$	Bus free time between a stop and start condition	Standard mode	4.7	$\mu\text{s}$	
		Fast mode	1.3		
		Fast mode+	0.5		
$t_{SU;STO}$	Setup time for a stop condition	Standard mode	4	$\mu\text{s}$	
		Fast mode	0.6		
		Fast mode+	0.26	ns	
		High-speed mode	160		
$t_{rDA}$	Rise time of SDA signal	Standard mode		1000	ns
		Fast mode	20	300	
		Fast mode+		120	
		High-speed mode, $C_b = 100\text{ pF}$	10	80	
		High-speed mode, $C_b = 400\text{ pF}$	20	160	

## I<sup>2</sup>C Serial Bus Timing Requirements (continued)

These specifications are ensured by design. Unless otherwise noted,  $V_{IN\_Bx} = 3.7\text{ V}$ .

		MIN	MAX	UNIT	
$t_{fDA}$	Fall time of SDA signal	Standard mode	300	ns	
		Fast mode	$20 \times (V_{DD} / 5.5\text{ V})$		300
		Fast mode+	$20 \times (V_{DD} / 5.5\text{ V})$		120
		High-speed mode, $C_b = 100\text{ pF}$	10		80
		High-speed mode, $C_b = 400\text{ pF}$	30		160
$t_{rCL}$	Rise time of SCL signal	Standard mode	1000	ns	
		Fast mode	20		300
		Fast mode+			120
		High-speed mode, $C_b = 100\text{ pF}$	10		40
		High-speed mode, $C_b = 400\text{ pF}$	20		80
$t_{rCL1}$	Rise time of SCL signal after a repeated start condition and after an acknowledge bit	High-speed mode, $C_b = 100\text{ pF}$	10	ns	
		High-speed mode, $C_b = 400\text{ pF}$	20		160
$t_{fCL}$	Fall time of a SCL signal	Standard mode	300	ns	
		Fast mode	$20 \times (V_{DD} / 5.5\text{ V})$		300
		Fast mode+	$20 \times (V_{DD} / 5.5\text{ V})$		120
		High-speed mode, $C_b = 100\text{ pF}$	10		40
		High-speed mode, $C_b = 400\text{ pF}$	20		80
$C_b$	Capacitive load for each bus line (SCL and SDA)		400	pF	
$t_{SP}$	Pulse width of spike suppressed (SCL and SDA spikes that are less than the indicated width are suppressed)	Standard mode, fast mode and fast mode+	50	ns	
		High-speed mode	10		



图 1. I<sup>2</sup>C Timing

### 6.7 Typical Characteristics

Unless otherwise specified:  $T_A = 25^\circ\text{C}$ ,  $V_{IN} = 3.7\text{ V}$ ,  $V_{OUT} = 1\text{ V}$ ,  $V_{(NRST)} = 1.8\text{ V}$ ,  $f_{SW} = 4\text{ MHz}$ ,  $L = 0.47\text{ }\mu\text{H}$  (TOKO DFE252012PD-R47M),  $C_{OUT} = 22\text{ }\mu\text{F}$  / phase,  $C_{POL} = 22\text{ }\mu\text{F}$  / phase.

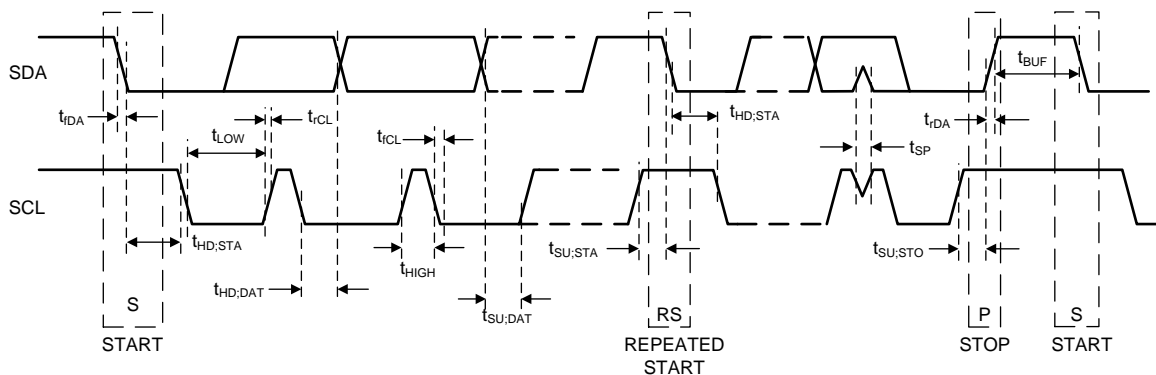

图 2. Shutdown Current Consumption vs Input Voltage



图 3. Standby Current Consumption vs Input Voltage

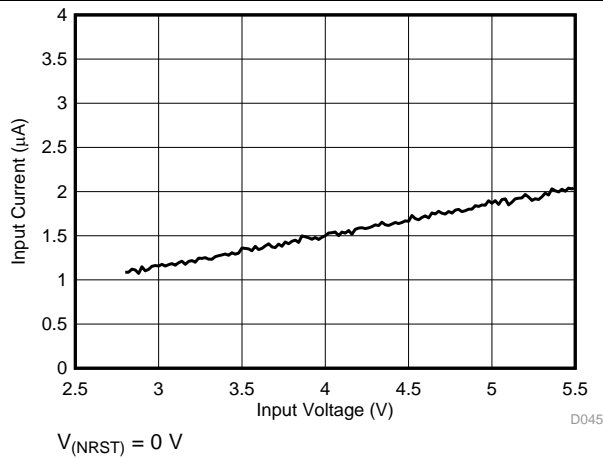

图 4. PFM Mode Current Consumption vs Input Voltage, One Regulator Enabled

## 7 Detailed Description

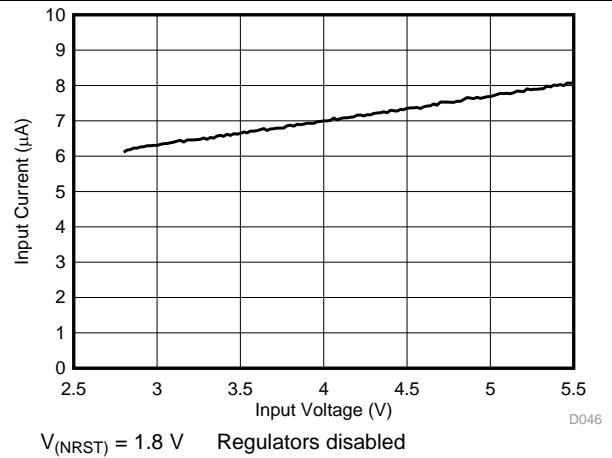
### 7.1 Overview

The LP87524B/J/P-Q1 is a high-efficiency, high-performance power supply device with four step-down DC-DC converter cores for automotive applications. 表 1 lists the output characteristics of the regulators.

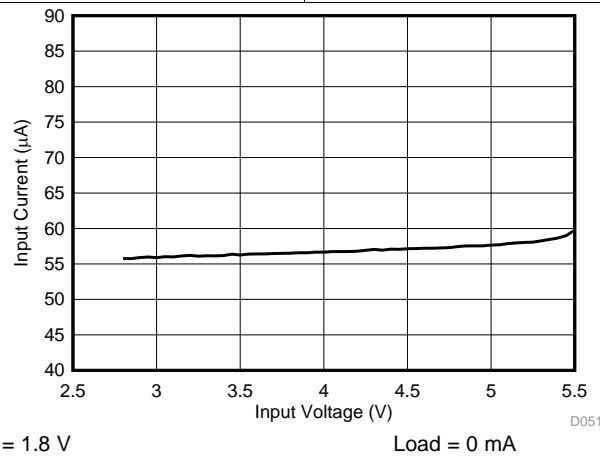
表 1. Supply Specification

SUPPLY	OUTPUT		
	V <sub>OUT</sub> RANGE (V)	RESOLUTION (mV)	I <sub>MAX</sub> MAXIMUM OUTPUT CURRENT (A)
Buck0	0.6 to 3.36 (V <sub>IN</sub> = 2.8 V - 4 V) 1.0 to 3.36 (V <sub>IN</sub> = 2.8 V - 5.5 V)	10 (0.6 V to 0.73 V) 5 (0.73 V to 1.4 V) 20 (1.4 V to 3.36 V)	10 A total
Buck1	0.6 to 3.36 (V <sub>IN</sub> = 2.8 V - 4 V) 1.0 to 3.36 (V <sub>IN</sub> = 2.8 V - 5.5 V)	10 (0.6 V to 0.73 V) 5 (0.73 V to 1.4 V) 20 (1.4 V to 3.36 V)	
Buck2	0.6 to 3.36 (V <sub>IN</sub> = 2.8 V - 4 V) 1.0 to 3.36 (V <sub>IN</sub> = 2.8 V - 5.5 V)	10 (0.6 V to 0.73 V) 5 (0.73 V to 1.4 V) 20 (1.4 V to 3.36 V)	
Buck3	0.6 to 3.36 (V <sub>IN</sub> = 2.8 V - 4 V) 1.0 to 3.36 (V <sub>IN</sub> = 2.8 V - 5.5 V)	10 (0.6 V to 0.73 V) 5 (0.73 V to 1.4 V) 20 (1.4 V to 3.36 V)	
<b>LP87524B-Q1 default settings:</b>	<b>V<sub>OUT</sub> (V)</b>	<b>I<sub>MAX</sub> MAXIMUM OUTPUT CURRENT (A)</b>	<b>AWR / IWR Rail</b>
Buck0	3.3 V	1.5 A	IO
Buck1	1.2 V	1.5 A	Digital
Buck2	1.8 V	4 A	RF, with external LDO
Buck3	2.3 V	2.5 A	RF, with external LDO
<b>LP87524J-Q1 default settings:</b>	<b>V<sub>OUT</sub> (V)</b>	<b>I<sub>MAX</sub> MAXIMUM OUTPUT CURRENT (A)</b>	<b>AWR / IWR Rail</b>
Buck0	3.3 V	1.5 A	IO
Buck1	1.2 V	1.5 A	Digital
Buck2	1 V	4 A	RF, with ferrite filter
Buck3	1.8 V	2.5 A	RF, with ferrite filter
<b>LP87524P-Q1 default settings:</b>	<b>V<sub>OUT</sub> (V)</b>	<b>I<sub>MAX</sub> MAXIMUM OUTPUT CURRENT (A)</b>	<b>AWR / IWR Rail</b>
Buck0	1 V	3 A	RF, with ferrite filter
Buck1	1.2 V	1.5 A	Digital
Buck2	1 V	3 A	RF, with ferrite filter
Buck3	1.8 V	2.5 A	RF, with ferrite filter

The LP87524B/J/P-Q1 also supports switching clock synchronization to an external clock. The nominal frequency of the external clock can be from 1 MHz to 24 MHz with 1-MHz steps.

Additional features include:

- Soft start
- Input voltage protection:
  - Undervoltage lockout
  - Overvoltage protection
- Output voltage monitoring and protection:
  - Overvoltage monitoring
  - Undervoltage monitoring
  - Overload protection
- Thermal warning
- Thermal shutdown

Three enable signals can be multiplexed to general purpose I/O (GPIO) signals. The direction and output type (open-drain or push-pull) are programmable for the GPIOs.

## 7.2 Functional Block Diagram

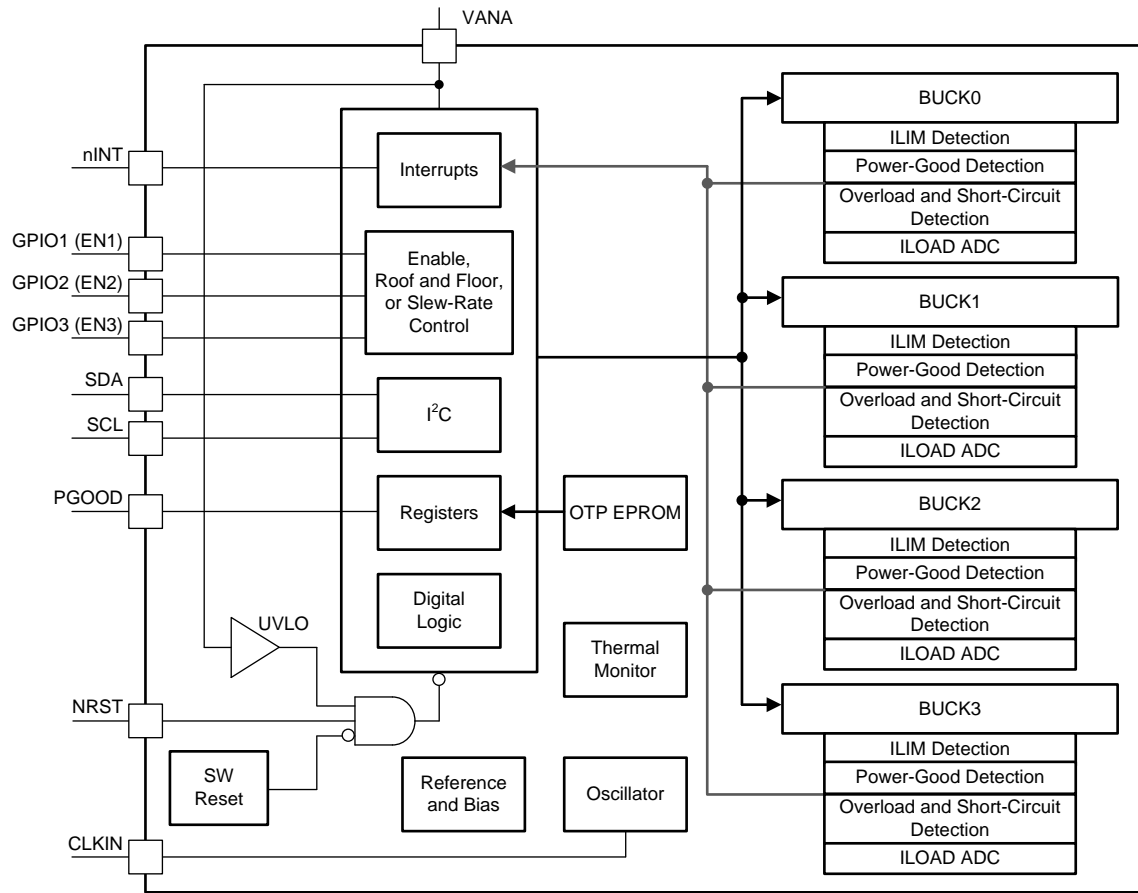

## 7.3 Feature Descriptions

### 7.3.1 DC-DC Converters

#### 7.3.1.1 Overview

The LP87524B/J/P-Q1 includes four step-down DC-DC converter cores configured for four single-phase outputs. The cores are designed for flexibility; most of the functions are programmable, thus giving a possibility to optimize the regulator operation for each application.

The LP87524B/J/P-Q1 has the following features:

- DVS support
- Automatic mode control based on the loading (PFM or PWM mode)
- Forced-PWM mode operation
- Optional external clock input to minimize crosstalk
- Optional spread spectrum technique to reduce EMI
- Phase control for optimized EMI
- Synchronous rectification
- Current mode loop with PI compensator
- Soft start
- Power Good flag with maskable interrupt
- Power Good signal (PGOOD) with selectable sources
- Average output current sensing (for PFM entry and load current measurement)

## Feature Descriptions (接下页)

The following parameters can be programmed via registers:

- Output voltage
- Forced-PWM operation
- Enable and disable delays for regulators and GPIOs controlled by ENx pins

There are two modes of operation for the converter, depending on the output current required: pulse-width modulation (PWM) and pulse-frequency modulation (PFM). The converter operates in PWM mode at high load currents of approximately 600 mA or higher. Lighter output current loads cause the converter to automatically switch into PFM mode for reduced current consumption when forced-PWM mode is disabled.

A multi-phase synchronous buck converter offers several advantages over a single power stage converter. For application processor power delivery, lower ripple on the input and output currents and faster transient response to load steps are the most significant advantages. Also, because the load current is evenly shared among multiple channels in multi-phase output configuration, the heat generated is greatly reduced for each channel due to the fact that power loss is proportional to square of current. The physical size of the output inductor shrinks significantly due to this heat reduction. A block diagram of a single core is shown in [图 5](#).

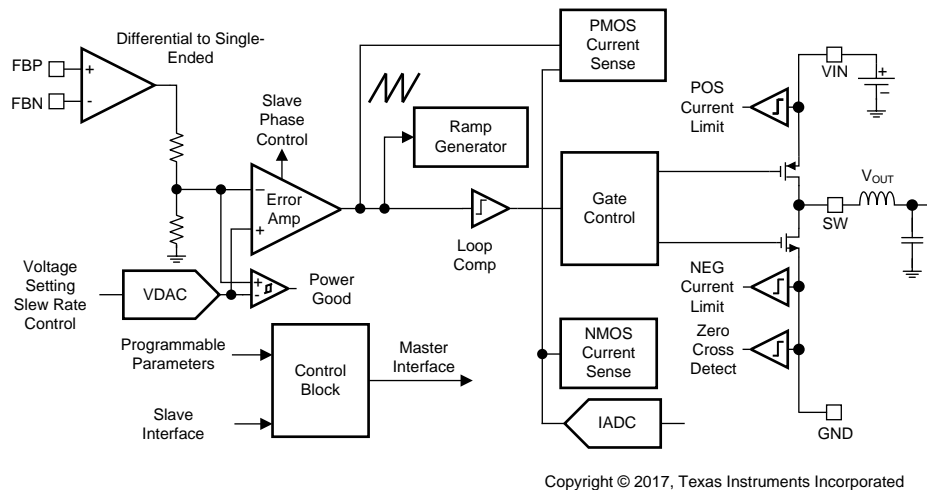

**图 5. Detailed Block Diagram Showing One Core**

### 7.3.1.2 Transition Between PWM and PFM Modes

The LP87524B/J/P-Q1 converter operates in PWM mode at load current of about 600 mA or higher. At lighter load-current levels the device automatically switches into PFM mode for reduced current consumption when forced-PWM mode is disabled (AUTO-mode operation). By combining the PFM and the PWM modes a high efficiency is achieved over a wide output-load-current range.

### 7.3.1.3 Buck Converter Load-Current Measurement

Buck load current can be monitored via I<sup>2</sup>C registers. The monitored buck converter is selected with the LOAD\_CURRENT\_BUCK\_SELECT[1:0] bits in SEL\_I\_LOAD register. A write to this selection register starts a current measurement sequence. The regulator is forced to PWM mode during the measurement. The measurement sequence is 50  $\mu$ s long, maximum. LP87524B/J/P-Q1 can be configured to give out an interrupt (I\_LOAD\_READY bit in INT\_TOP1 register) after the load current measurement sequence is finished. Load current measurement interrupt can be masked with I\_LOAD\_READY\_MASK bit (TOP\_MASK1 register). The measurement result can be read from registers I\_LOAD\_1 and I\_LOAD\_2. Register I\_LOAD\_1 bits BUCK\_LOAD\_CURRENT[7:0] give out the LSB bits and register I\_LOAD\_2 bits BUCK\_LOAD\_CURRENT[9:8] the MSB bits. The measurement result BUCK\_LOAD\_CURRENT[9:0] LSB is 20 mA, and maximum value of the measurement corresponds to 20.46 A.

## Feature Descriptions (接下页)

### 7.3.1.4 Spread-Spectrum Mode

Systems with periodic switching signals may generate a large amount of switching noise in a set of narrowband frequencies (the switching frequency and its harmonics). The usual solution to reduce noise coupling is to add EMI filters and shields to the boards. The LP87524B/J/P-Q1 device has register selectable spread-spectrum mode which minimizes the need for output filters, ferrite beads, or chokes. In spread-spectrum mode, the switching frequency varies around the center frequency, reducing the EMI emissions radiated by the converter and associated passive components and PCB traces (see 图 6). This feature is available only when internal RC oscillator is used (PLL\_MODE[1:0] = 00 in PLL\_CTRL register), and it is enabled with the EN\_SPREAD\_SPEC bit (PIN\_FUNCTION register), and it affects all the buck cores.

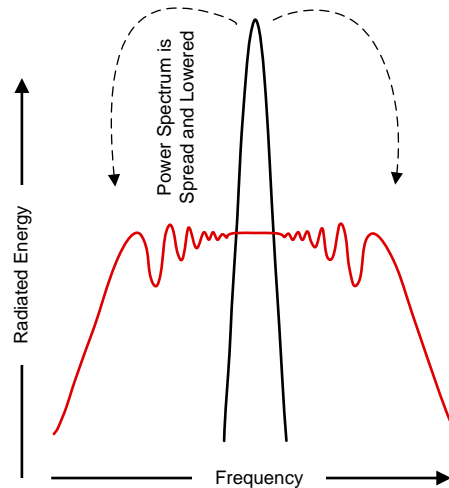

Where a fixed-frequency converter exhibits large amounts of spectral energy at the switching frequency, the spread-spectrum architecture of the LP87524B/J/P-Q1 spreads that energy over a large bandwidth.

图 6. Spread-Spectrum Modulation

### 7.3.2 Sync Clock Functionality

The LP87524B/J/P-Q1 device contains a CLKIN input to synchronize switching clock of the buck regulator with the external clock. The block diagram of the clocking and PLL module is shown in 图 7. Depending on the PLL\_MODE[1:0] bits (in PLL\_CTRL register) and the external clock availability, the external clock is selected and interrupt is generated as shown in 表 2. The interrupt can be masked with SYNC\_CLK\_MASK bit in TOP\_MASK1 register. The nominal frequency of the external input clock is set by EXT\_CLK\_FREQ[4:0] bits (in PLL\_CTRL register) and it can be from 1 MHz to 24 MHz with 1-MHz steps. The external clock must be inside accuracy limits (–30%/+10%) for valid clock detection.

The NO\_SYNC\_CLK interrupt (in INT\_TOP1 register) is also generated in cases the external clock is expected but it is not available. These cases are start-up (read OTP-to-STANDBY transition) when PLL\_MODE[1:0] = 01 and regulator enable (STANDBY-to-ACTIVE transition) when PLL\_MODE[1:0] = 10.

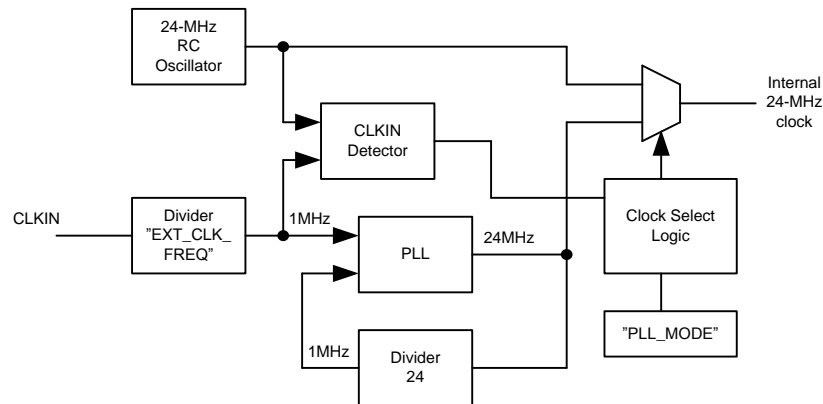
**Feature Descriptions (接下页)**

Copyright © 2017, Texas Instruments Incorporated

**图 7. Clock and PLL Module**
**表 2. PLL Operation**

DEVICE OPERATION MODE	PLL_MODE[1:0]	PLL AND CLOCK DETECTOR STATE	INTERRUPT FOR EXTERNAL CLOCK	CLOCK
STANDBY	00	Disabled	No	Internal RC
ACTIVE	00	Disabled	No	Internal RC
STANDBY	01	Enabled	When external clock appears or disappears	Automatic change to external clock when available
ACTIVE	01	Enabled	When external clock appears or disappears	Automatic change to external clock when available
STANDBY	10	Disabled	No	Internal RC
ACTIVE	10	Enabled	When external clock appears or disappears	Automatic change to external clock when available
STANDBY	11	Reserved		
ACTIVE	11	Reserved		

**7.3.3 Power-Up**

The power-up sequence for the LP87524B/J/P-Q1 is as follows:

- VANA (and VIN\_Bx) reach minimum recommended level ( $V_{VANA} > V_{ANA_{UVLO}}$ ).
- NRST is set to high level (or shorted to VANA). This initiates power-on-reset (POR), OTP reading and enables the system I/O interface. The I<sup>2</sup>C host must allow at least 1.2 ms before writing or reading data to the LP87524B/J/P-Q1.
- Device enters STANDBY-mode.
- The host can change the default register setting by I<sup>2</sup>C if needed.
- The regulator(s) can be enabled/disabled by ENx pin(s) and by I<sup>2</sup>C interface.

### 7.3.4 Regulator Control

#### 7.3.4.1 Enabling and Disabling Regulators

The regulator(s) can be enabled when the device is in STANDBY or ACTIVE state. There are two ways for enable and disable the regulators:

- Using EN\_BUCKx bit in BUCKx\_CTRL1 register (EN\_PIN\_CTRLx register bit is 0)
- Using EN1/2/3 control pins (EN\_BUCKx bit is 1 **AND** EN\_PIN\_CTRLx register bit is 1 in BUCKx\_CTRL1 register)

If the EN1/2/3 control pins are used for enable and disable then the control pin is selected with BUCKx\_EN\_PIN\_SELECT[1:0] bits (in BUCKx\_CTRL1 register). The delay from the control signal rising edge to enabling of the regulator is set by BUCKx\_STARTUP\_DELAY[3:0] bits and the delay from control signal falling edge to disabling of the regulator is set by BUCKx\_SHUTDOWN\_DELAY[3:0] bits in BUCKx\_DELAY register. The delays are valid only for EN1/2/3 signal control. The control with EN\_BUCKx bit is immediate without the delays.

The control of the regulator (with 0-ms delays) is shown in [表 3](#).

#### 注

The control of the regulator cannot be changed from one ENx pin to a different ENx pin because the control is ENx signal edge sensitive. The control from ENx pin to register bit and back to the original ENx pin can be done during operation.

**表 3. Regulator Control**

CONTROL METHOD	EN_BUCKx	EN_PIN_CTRLx	BUCKx_EN_PIN_SELECT[1:0]	EN_ROOF_FLOOR_x	EN1 PIN	EN2 PIN	EN3 PIN	BUCKx OUTPUT VOLTAGE
Enable/disable control with EN_BUCKx bit	0	Don't Care	Don't Care	Don't Care	Don't Care	Don't Care	Don't Care	Disabled
	1	0	Don't Care	Don't Care	Don't Care	Don't Care	Don't Care	BUCKx_VSET[7:0]
Enable/disable control with EN1 pin	1	1	00	0	Low	Don't Care	Don't Care	Disabled
	1	1	00	0	High	Don't Care	Don't Care	BUCKx_VSET[7:0]
Enable/disable control with EN2 pin	1	1	01	0	Don't Care	Low	Don't Care	Disabled
	1	1	01	0	Don't Care	High	Don't Care	BUCKx_VSET[7:0]
Enable/disable control with EN3 pin	1	1	10	0	Don't Care	Don't Care	Low	Disabled
	1	1	10	0	Don't Care	Don't Care	High	BUCKx_VSET[7:0]
Roof/floor control with EN1 pin	1	1	00	1	Low	Don't Care	Don't Care	BUCKx_FLOOR_VSET[7:0]
	1	1	00	1	High	Don't Care	Don't Care	BUCKx_VSET[7:0]
Roof/floor control with EN2 pin	1	1	01	1	Don't Care	Low	Don't Care	BUCKx_FLOOR_VSET[7:0]
	1	1	01	1	Don't Care	High	Don't Care	BUCKx_VSET[7:0]
Roof/floor control with EN3 pin	1	1	10	1	Don't Care	Don't Care	Low	BUCKx_FLOOR_VSET[7:0]
	1	1	10	1	Don't Care	Don't Care	High	BUCKx_VSET[7:0]

The regulator is enabled by the ENx pin or by I<sup>2</sup>C writing as shown in [图 8](#). The soft-start circuit limits the in-rush current during start-up. When the output voltage rises to 0.35-V level, the output voltage becomes slew-rate controlled. If there is a short circuit at the output and the output voltage does not increase above 0.35-V level in 1 ms, the regulator is disabled, and interrupt is set. When the output voltage reaches the Power-Good threshold level the BUCKx\_PG\_INT interrupt flag (in INT\_BUCK\_x register) is set. The Power-Good interrupt flag can be masked using BUCKx\_PG\_MASK bit (in BUCKx\_MASK register).

The ENx input pins have integrated pulldown resistors. The pulldown resistors are enabled by default, and the host can disable those with ENx\_PD bits (in CONFIG register).

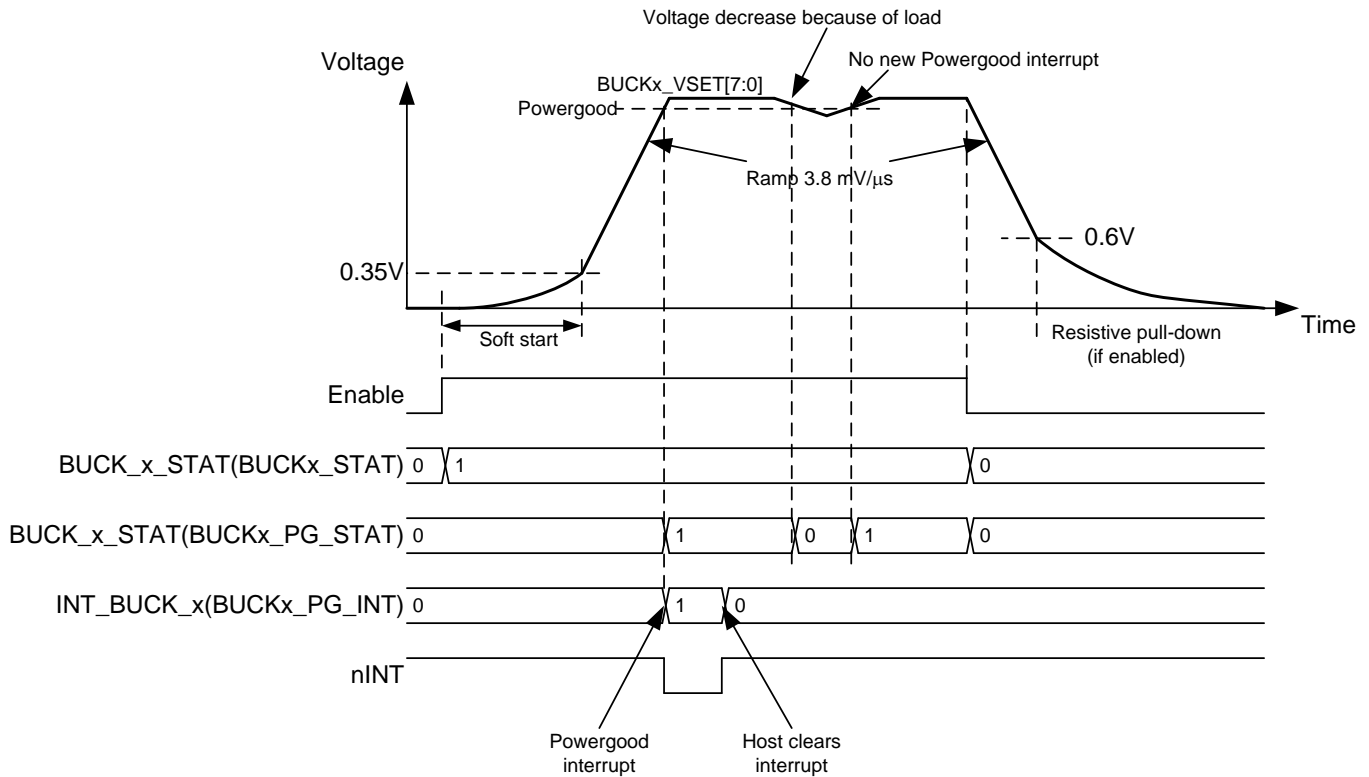
**图 8. Regulator Enable and Disable**

### 7.3.4.2 Changing Output Voltage

The output voltage of the regulator can be changed by the ENx pin (voltage levels defined by the BUCKx\_VOUT and BUCKx\_FLOOR\_VOUT registers) or by writing to the BUCKx\_VOUT and BUCKx\_FLOOR\_VOUT registers. The voltage change is always slew-rate controlled, 3.8 mV/µs. During voltage change the forced-PWM mode is used automatically. When the programmed output voltage is achieved, the mode becomes the one defined by the load current and the BUCKx\_FPWM bit in BUCKx\_CTRL1 register.

The Power-Good interrupt is generated when the output voltage reaches the programmed voltage level, as shown in 图 9.



图 9. Regulator Output Voltage Change With ENx pin

### 7.3.5 Enable and Disable Sequences

The LP87524B/J/P-Q1 device supports start-up and shutdown sequencing with programmable delays for different regulator outputs using single EN1/2/3 control signal. The regulator is selected for delayed control with:

- EN\_BUCKx = 1 (in BUCKx\_CTRL1 register)
- EN\_PIN\_CTRLx = 1 (in BUCKx\_CTRL1 register)
- EN\_ROOF\_FLOORx = 0 (in BUCKx\_CTRL1 register)
- BUCKx\_VSET[7:0] = Required voltage when ENx is high (in BUCKx\_VOUT register)
- The ENABLE pin for control is selected with BUCKx\_EN\_PIN\_SELECT[1:0] (in BUCKx\_CTRL1 register)
- The delay from rising edge of ENx signal to the regulator enable is set by BUCKx\_STARTUP\_DELAY[3:0] bits (in BUCKx\_DELAY register) and
- The delay from falling edge of ENx signal to the regulator disable is set by BUCKx\_SHUTDOWN\_DELAY[3:0] bits (in BUCKx\_DELAY register)

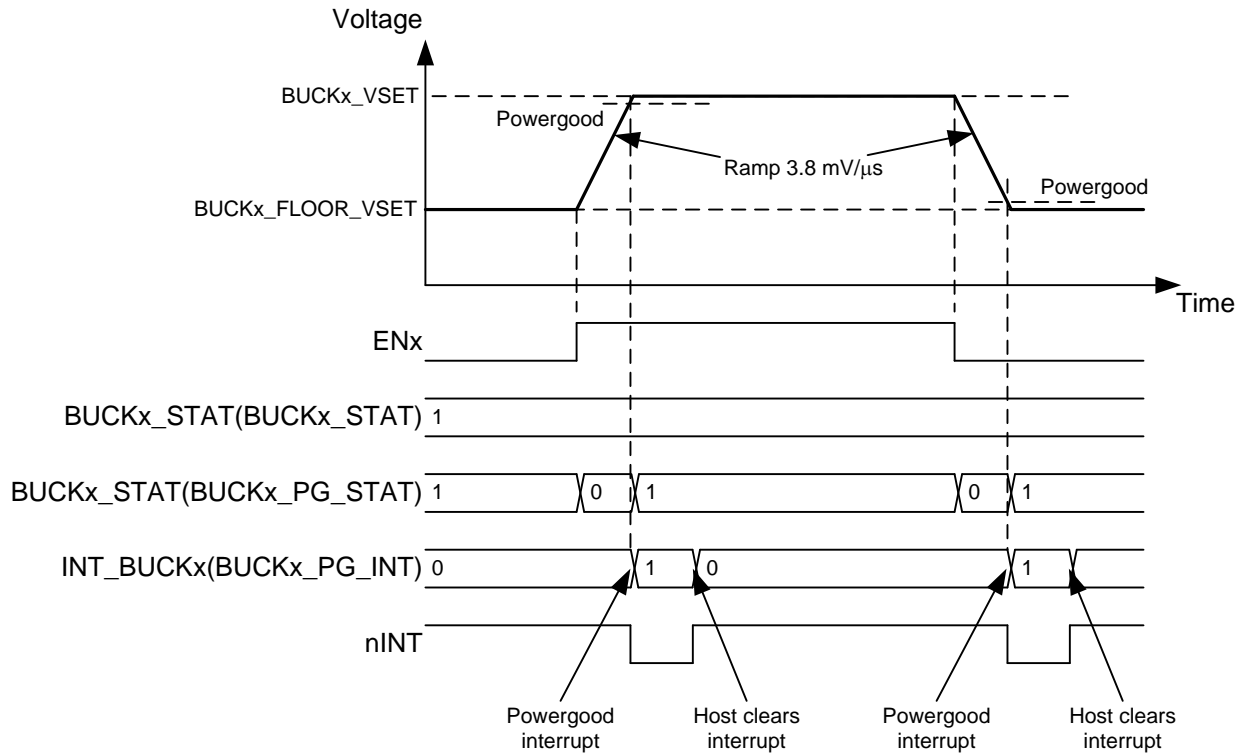
There are four time steps available for start-up and shutdown sequences. The delay times are selected with DOUBLE\_DELAY bit in CONFIG register and HALF\_DELAY bit in PGOOD\_CTRL2 register as shown in 表 4.

**表 4. Start-up and Shutdown Delays**

X_STARTUP_DELAY / X_SHUTDOWN_DELAY	DOUBLE_DELAY = 0 HALF_DELAY = 1	DOUBLE_DELAY = 1 HALF_DELAY = 1	DOUBLE_DELAY = 0 HALF_DELAY = 0	DOUBLE_DELAY = 1 HALF_DELAY = 0
0000	0 ms	0 ms	0 ms	0 ms
0001	0.32 ms	0.64 ms	1 ms	2 ms
0010	0.64 ms	1.28 ms	2 ms	4 ms
0011	0.96 ms	1.92 ms	3 ms	6 ms
0100	1.28 ms	2.56 ms	4 ms	8 ms
0101	1.6 ms	3.2 ms	5 ms	10 ms
0110	1.92 ms	3.84 ms	6 ms	12 ms
0111	2.24 ms	4.48 ms	7 ms	14 ms
1000	2.56 ms	5.12 ms	8 ms	16 ms
1001	2.88 ms	5.76 ms	9 ms	18 ms
1010	3.2 ms	6.4 ms	10 ms	20 ms
1011	3.52 ms	7.04 ms	11 ms	22 ms
1100	3.84 ms	7.68 ms	12 ms	24 ms
1101	4.16 ms	8.32 ms	13 ms	26 ms
1110	4.48 ms	8.96 ms	14 ms	28 ms
1111	4.8 ms	9.6 ms	15 ms	30 ms

An example of start-up and shutdown sequences is shown in 图 10 and 图 11. The start-up and shutdown delays for the Buck0/1 regulators are 1 ms and 4 ms and for the Buck2/3 regulators 3 ms and 1 ms. The delay settings are used only for enable/disable control with EN1/2/3 signals, not for Roof/Floor control.



**图 10. Typical Start-Up and Shutdown Sequencing**

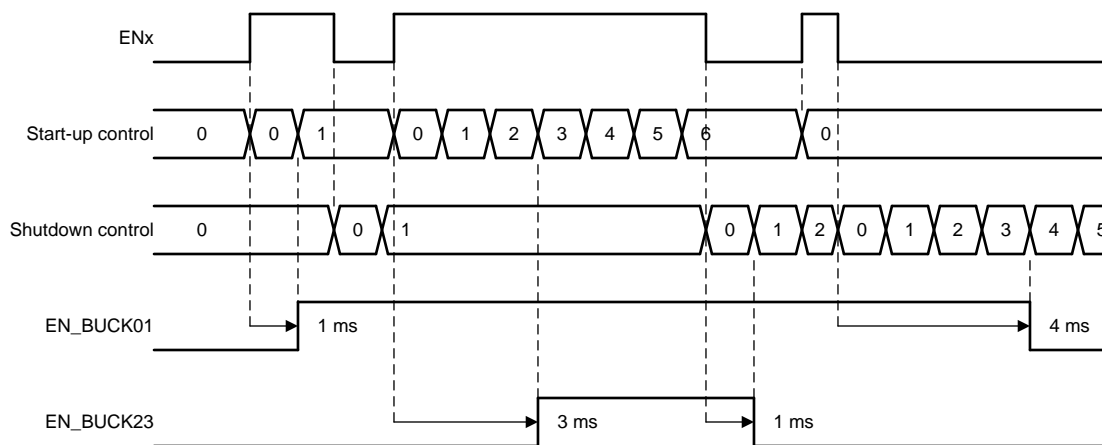

**图 11. Start-Up and Shutdown Sequencing With Short ENx Low and High Periods**

### 7.3.6 Device Reset Scenarios

There are three reset methods implemented on the LP87524B/J/P-Q1:

- Software reset with SW\_RESET register bit (in RESET register)
- POR from rising edge of NRST signal
- Undervoltage lockout (UVLO) reset from VANA supply

A SW-reset occurs when SW\_RESET bit is written 1. The bit is automatically cleared after writing. This event disables all the regulators immediately, resets all the register bits to the default values and OTP bits are loaded (see 图 15). I<sup>2</sup>C interface is not reset during software reset. The host must wait at least 1.2 ms after writing SW reset until making a new I<sup>2</sup>C read or write to the device.

If VANA supply voltage falls below UVLO threshold level or NRST signal is set low then all the regulators are disabled immediately, and all the register bits are reset to the default values. When the VANA supply voltage rises above UVLO threshold level **AND** NRST signal rises above threshold level an internal power-on reset (POR) occurs. OTP bits are loaded to the registers and a start-up is initiated according to the register settings. The host must wait at least 1.2 ms after POR until reading or writing to I<sup>2</sup>C interface.

### 7.3.7 Diagnosis and Protection Features

The LP87524B/J/P-Q1 is capable of providing four levels of protection features:

- Information of valid regulator output voltage which sets interrupt or PGOOD signal;
- Warnings for diagnosis which sets interrupt;
- Protection events which are disabling the regulators affected; and
- Faults which are causing the device to shutdown.

The LP87524B/J/P-Q1 sets the flag bits indicating what protection or warning conditions have occurred, and the nINT pin is pulled low. nINT is released again after a clear of flags is complete. The nINT signal stays low until all the pending interrupts are cleared.

When a fault is detected, it is indicated by a RESET\_REG interrupt flag (in INT2\_TOP register) after next start-up.

**表 5. Summary of Interrupt Signals**

EVENT	RESULT	INTERRUPT REGISTER AND BIT	INTERRUPT MASK	STATUS BIT	RECOVERY/INTERRUPT CLEAR
Current limit triggered (20- $\mu$ s debounce)	Interrupt	INT_BUCKx = 1 BUCKx_ILIM_INT = 1	BUCKx_ILIM_MASK	BUCKx_ILIM_STAT	Write 1 to BUCKx_ILIM_INT bit Interrupt is not cleared if current limit is active
Short circuit ( $V_{OUT} < 0.35$ V at 1 ms after enable) or overload ( $V_{OUT}$ decreasing below 0.35 V during operation, 1 ms debounce)	Regulator disable and interrupt	INT_BUCKx = 1 BUCKx_SC_INT = 1	N/A	N/A	Write 1 to BUCKx_SC_INT bit
Thermal warning	Interrupt	TDIE_WARN = 1	TDIE_WARN_MASK	TDIE_WARN_STAT	Write 1 to TDIE_WARN bit Interrupt is not cleared if temperature is above thermal warning level
Thermal whutdown	All regulators disabled and Output GPIOx set to low and interrupt	TDIE_SD = 1	N/A	TDIE_SD_STAT	Write 1 to TDIE_SD bit Interrupt is not cleared if temperature is above thermal shutdown level
VANA overvoltage ( $VANA_{OVP}$ )	All regulators disabled and Output GPIOx set to low and interrupt	INT_OVP	N/A	OVP_STAT	Write 1 to INT_OVP bit Interrupt is not cleared if VANA voltage is above VANA OVP level
Power Good, output voltage reaches the programmed value	Interrupt	INT_BUCKx = 1 BUCKx_PG_INT = 1	BUCKx_PG_MASK	BUCKx_PG_STAT	Write 1 to BUCKx_PG_INT bit
GPIO	Interrupt	INT_GPIO	GPIO_MASK	GPIO_IN register	Write 1 to INT_GPIO bit
External clock appears or disappears	Interrupt	NO_SYNC_CLK <sup>(1)</sup>	SYNC_CLK_MASK	SYNC_CLK_STAT	Write 1 to NO_SYNC_CLK bit
Load current measurement ready	Interrupt	I_LOAD_READY = 1	I_LOAD_READY_MASK	N/A	Write 1 to I_LOAD_READY bit

(1) Interrupt is generated during clock detector operation and in case clock is not available when clock detector is enabled.

**表 5. Summary of Interrupt Signals (接下页)**

EVENT	RESULT	INTERRUPT REGISTER AND BIT	INTERRUPT MASK	STATUS BIT	RECOVERY/INTERRUPT CLEAR
Start-up (NRST rising edge)	Device ready for operation, registers reset to default values and interrupt	RESET_REG = 1	RESET_REG_MASK	N/A	Write 1 to RESET_REG bit
Glitch on supply voltage and UVLO triggered (VANA falling and rising)	Immediate shutdown followed by power up, registers reset to default values and interrupt	RESET_REG = 1	RESET_REG_MASK	N/A	Write 1 to RESET_REG bit
Software requested reset	Immediate shutdown followed by power up, registers reset to default values and interrupt	RESET_REG = 1	RESET_REG_MASK	N/A	Write 1 to RESET_REG bit

### 7.3.7.1 Power-Good Information (PGOOD pin)

In addition to the interrupt based indication of current limit and Power-Good level the LP87524B/J/P-Q1 device supports the indication with PGOOD signal. Either voltage and current monitoring or a voltage monitoring only can be selected for PGOOD indication. This selection is individual for all buck regulators and is set by PGx\_SEL[1:0] bits (in PGOOD\_CTRL1 register). When both voltage and current are monitored, PGOOD signal active indicates that regulator output is inside the Power-Good voltage window and that load current is below  $I_{LIM\_FWD}$ . If only voltage is monitored, then the current monitoring is ignored for the PGOOD signal. When a regulator is disabled, the monitoring is automatically masked to prevent it forcing PGOOD inactive. This allows connecting PGOOD signals from various devices together when open-drain outputs are used. When regulator voltage is transitioning from one target voltage to another, the voltage monitoring PGOOD signal is set inactive. The monitoring from all the output rails are combined, and PGOOD is active only if all the sources shows active status. The status from all the voltage rails are summarized in [表 6](#).

If the PGOOD signal is inactive or it changes the state to inactive, the source for the state can be read from PGOOD\_FLT register. During reading all the PGx\_FLT bit are cleared that are not driving the PGOOD inactive. When PGOOD signal goes active, the host must read the PGOOD\_FLT register to clear all the bits. The PGOOD signal follows the status of all the monitored outputs.

The PGOOD signal can be also configured so that it maintains inactive state even when the monitored outputs are valid but there are PGx\_FLT bits pending clearance in PGOOD\_FLT register. This mode of operation is selected by setting EN\_PGFLT\_STAT bit to 1 (in PGOOD\_CTRL2 register).

The type of output voltage monitoring for PGOOD signal is selected by PGOOD\_WINDOW bit (in PGOOD\_CTRL2 register). If the bit is 0, only undervoltage is monitored; if the bit is 1, both undervoltage and overvoltage are monitored.

The polarity and the output type (push-pull or open-drain) are selected by PGOOD\_POL and PGOOD\_OD bits in PGOOD\_CTRL2 register.

The filtering time for invalid output voltage is always typically 7  $\mu$ s and for valid output voltage the filtering time is selected with PGOOD\_SET\_DELAY bit (in PGOOD\_CTRL2 register). The Power-Good waveforms are shown in [图 13](#).

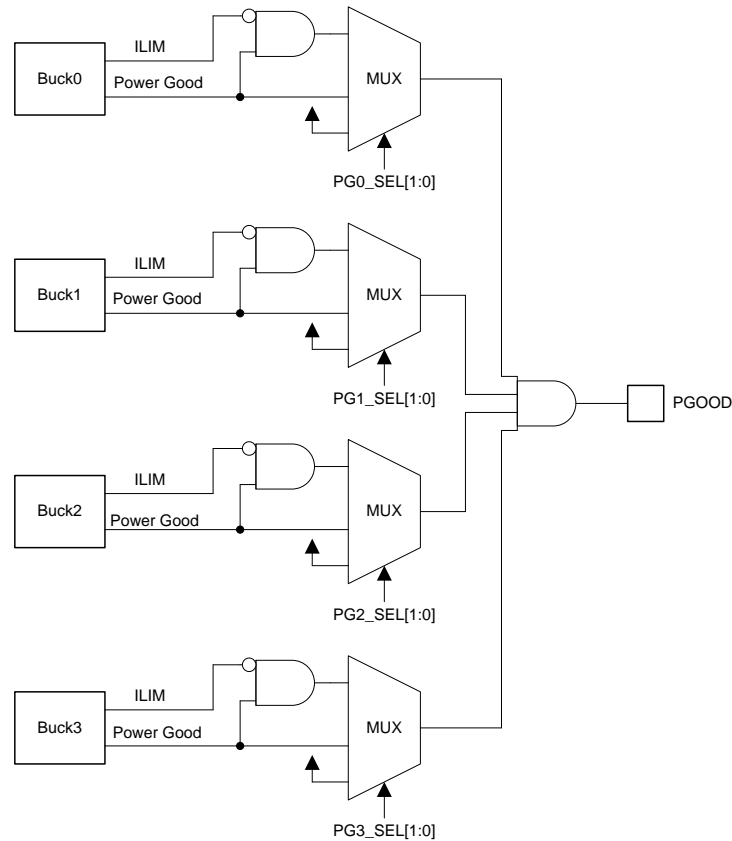

Copyright © 2017, Texas Instruments Incorporated

图 12. PGOOD Block Diagram

表 6. PGOOD Operation

STATUS / USE CASE	CONDITION	INPUT TO PGOOD SIGNAL
Buck not selected for PGOOD monitoring	PGx_SEL = 00 (in PGOOD_CTRL1 register)	Active
Buck disabled		Active
<b>BUCK SELECTED FOR PGOOD MONITORING</b>		
Buck start-up delay		Inactive
Buck soft start	$V_{OUT} < 0.35\text{ V}$	Inactive
Buck voltage ramp-up	$0.35\text{ V} < V_{OUT} < V_{SET}$	Inactive
Output voltage within window limits after start-up	Must be inside limits longer than debounce time	Active
Output voltage inside voltage window and current limit active	Current limit active longer than debounce time	Active (if only voltage monitoring selected) Inactive (if also current monitoring selected)
Output voltage spikes (overvoltage or undervoltage)	If spikes are outside voltage window longer than debounce time	Inactive
Voltage setting change, output voltage ramp		Inactive
Output voltage within window limits after voltage change	Must be inside limits longer than debounce time	Active
Buck shutdown delay		Active
Buck output voltage ramp down		Active

**表 6. PGOOD Operation (接下页)**

STATUS / USE CASE	CONDITION	INPUT TO PGOOD SIGNAL
Buck disabled by thermal shutdown and interrupt pending		Inactive
Buck disabled by overvoltage and interrupt pending		Inactive
Buck disabled by short-circuit detection and interrupt pending		Inactive

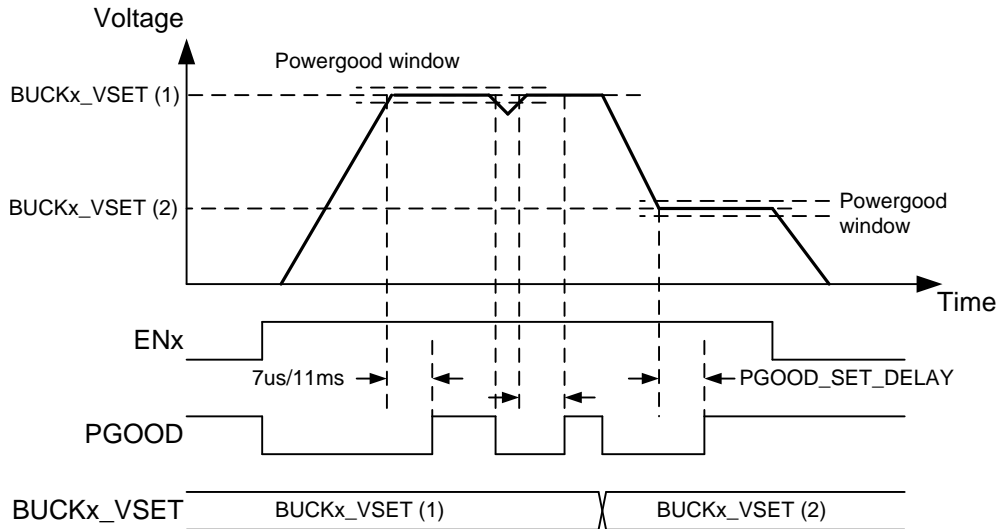
**图 13. PGOOD Waveforms (PGOOD\_POL=0)**

### 7.3.7.2 Warnings for Diagnosis (Interrupt)

#### 7.3.7.2.1 Output Power Limit

The regulators have output peak current limits. The peak current limits are described in [Specifications](#). If the load current is increased so that the current limit is triggered, the regulator continues to regulate to the limit current level (current peak regulation, peak on every switching cycle). The voltage may decrease if the load current is higher than the average output current. If the current regulation continues for 20  $\mu$ s, the LP87524B/J/P-Q1 device sets the BUCKx\_ILIM\_INT bit (in INT\_BUCKx register) and pulls the nINT pin low. The host processor can read BUCKx\_ILIM\_STAT bits (in BUCKx\_STAT register) to see if the regulator is still in peak current regulation mode.

If the load is so high that the output voltage decreases below a 350-mV level, the LP87524B/J/P-Q1 device disables the regulator and sets the BUCKx\_SC\_INT bit (in INT\_BUCKx register). In addition the BUCKx\_STAT bit (in BUCKx\_STAT register) is set to 0. The interrupt is cleared when the host processor writes 1 to BUCKx\_SC\_INT bit. The overload situation is shown in [图 14](#).



图 14. Overload Situation

### 7.3.7.2.2 Thermal Warning

The LP87524B/J/P-Q1 device includes a monitoring feature against overtemperature by setting an interrupt for host processor. The threshold level of the thermal warning is selected with TDIE\_WARN\_LEVEL bit (in CONFIG register).

If the LP87524B/J/P-Q1 device temperature increases above thermal warning level the device sets TDIE\_WARN bit (in INT\_TOP1 register) and pulls nINT pin low. The status of the thermal warning can be read from TDIE\_WARN\_STAT bit (in TOP\_STAT register), and the interrupt is cleared by writing 1 to TDIE\_WARN bit.

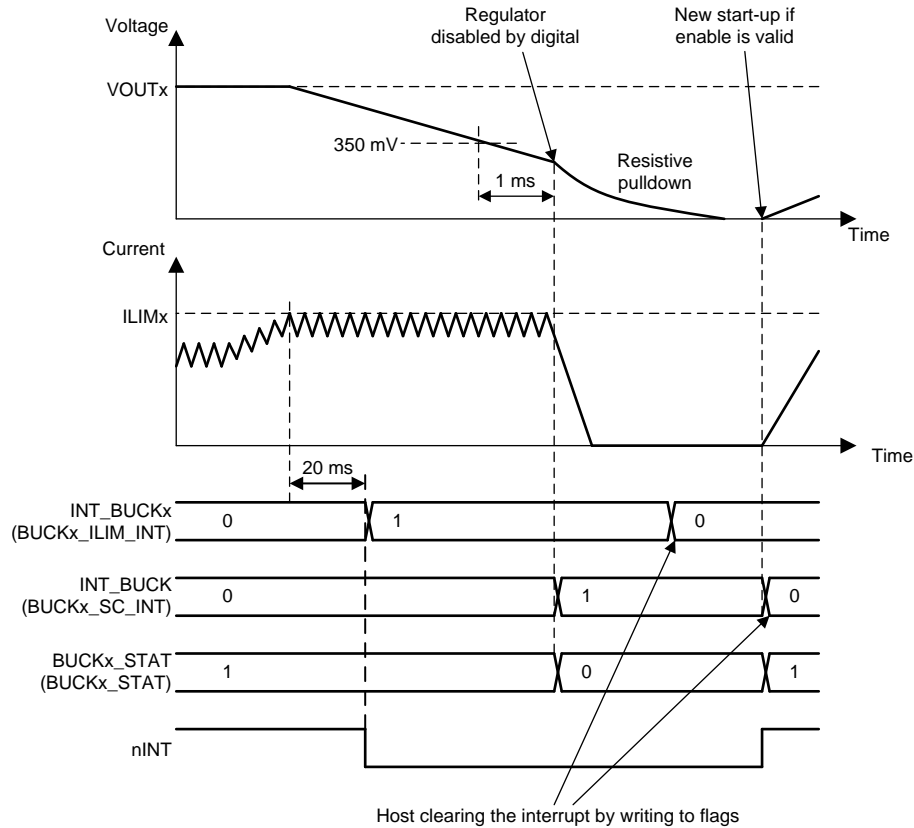
### 7.3.7.3 Protection (Regulator Disable)

If the regulator is disabled because of protection or fault (short-circuit protection, overload protection, thermal shutdown, overvoltage protection, or UVLO), the output power FETs are set to high-impedance mode, and the output pull-down resistor is enabled (if enabled with EN\_RDISx bits in BUCKx\_CTRL1 register). The turnoff time of the output voltage is defined by the output capacitance, load current, and the resistance of the integrated pull-down resistor. The pull-down resistors are active as long as VANA voltage is above approximately a 1.2-V level.

### 7.3.7.3.1 Short-Circuit and Overload Protection

A short-circuit protection feature allows the LP87524B/J/P-Q1 to protect itself and external components against short circuit at the output or against overload during start-up. The fault threshold is 350 mV, the protection is triggered, and the regulator is disabled if the output voltage is below the threshold level 1 ms after the regulator is enabled.

In a similar way the overload situation is protected during normal operation. If the voltage on the feedback pin of the regulator falls below 0.35 V and remains below the threshold level for 1 ms, the regulator is disabled.

In the short-circuit and overload situations the BUCKx\_SC\_INT (in INT\_BUCKx register) and the INT\_BUCKx bits (in INT\_TOP1 register) are set to 1, the BUCKx\_STAT bit (in BUCKx\_STAT register) is set to 0, and the nINT signal is pulled low. The host processor clears the interrupt by writing 1 to the BUCKx\_SC\_INT bit. Upon clearing the interrupt the regulator makes a new start-up attempt if the regulator is in enabled state.

### 7.3.7.3.2 Overvoltage Protection

The LP87524B/J/P-Q1 device monitors the input voltage from the VANA pin in standby and active operation modes. If the input voltage rises above  $VANA_{OVP}$  voltage level, all the regulators are disabled, pulldown resistors discharge the output voltages (if EN\_RDISx = 1 in BUCKx\_CTRL1 register), GPIOs that are configured to outputs are set to logic low level, nINT signal is pulled low, INT\_OVP bit (in INT\_TOP1 register) is set to 1, and BUCKx\_STAT bits (in BUCK\_x\_STAT register) are set to 0. The host processor clears the interrupt by writing 1 to the INT\_OVP bit. If the input voltage is above the overvoltage detection level the interrupt is not cleared. The host can read the status of the overvoltage from the OVP\_STAT bit (in TOP\_STAT register). Regulators cannot be enabled as long as the input voltage is above overvoltage detection level or the overvoltage interrupt is pending.

### 7.3.7.3.3 Thermal Shutdown

The LP87524B/J/P-Q1 has an overtemperature protection function that operates to protect the device from short-term misuse and overload conditions. When the junction temperature exceeds around 150°C, the regulators are disabled, the TDIE\_SD bit (in INT\_TOP1 register) is set to 1, the nINT signal is pulled low, and the device enters STANDBY. nINT is cleared by writing 1 to the TDIE\_SD bit. If the temperature is above thermal shutdown level the interrupt is not cleared. The host can read the status of the thermal shutdown from the TDIE\_SD\_STAT bit (in TOP\_STAT register). Regulators cannot be enabled as long as the junction temperature is above thermal shutdown level or the thermal shutdown interrupt is pending.

### 7.3.7.4 Fault (Power Down)

#### 7.3.7.4.1 Undervoltage Lockout

When the input voltage falls below  $VANA_{UVLO}$  at the VANA pin, the buck converters are disabled immediately, and the output capacitors are discharged using the pulldown resistor, and the LP87524B/J/P-Q1 device enters SHUTDOWN. When VANA voltage is above UVLO threshold level and NRST signal is high, the device powers up to STANDBY state.

If the reset interrupt is unmasked by default (RESET\_REG\_MASK = 0 in TOP\_MASK2 register) the RESET\_REG interrupt (in INT\_TOP2 register) indicates that the device has been in SHUTDOWN. The host processor must clear the interrupt by writing 1 to the RESET\_REG bit. If the host processor reads the RESET\_REG flag after detecting an nINT low signal, it knows that the input supply voltage has been below UVLO level (or the host has requested reset), and the registers are reset to default values.

### 7.3.8 GPIO Signal Operation

The LP87524B/J/P-Q1 device supports up to 3 GPIO signals. The GPIO signals are multiplexed with enable signals. The selection between enable and GPIO function is set with GPIOx\_SEL bits in PIN\_FUNCTION register. The GPIOs are mapped to EN signals so that:

- EN1 is multiplexed with GPIO1
- EN2 is multiplexed with GPIO2
- EN3 is multiplexed with GPIO3

When the pin is selected for GPIO function, additional bits defines how the GPIO operates:

- GPIOx\_DIR defines the direction of the GPIO, input or output (GPIO\_CONFIG register)
- GPIOx\_OD defines the type of the output when the GPIO is set to output, either push-pull with VANA level or open-drain (GPIO\_CONFIG register)

When the GPIOx is defined as output, the logic level of the pin is set by GPIOx\_OUT bit (in GPIO\_OUT register).

When the GPIOx is defined as input, the logic level of the pin can be read from GPIOx\_IN bit (in GPIO\_IN register).

The control of the GPIOs configured to outputs can be included to start-up and shutdown sequences. The GPIO control for a sequence with ENx signal is selected by EN\_PIN\_CTRL\_GPIOx and EN\_PIN\_SELECT\_GPIOx bits (in PIN\_FUNCTION register). The delays during start-up and shutdown are set by GPIOx\_STARTUP\_DELAY[3:0] and GPIOx\_SHUTDOWN\_DELAY[3:0] bits (in GPIOx\_DELAY register) in the same way as control of the regulators.

The GPIOx signals have a selectable pulldown resistor. The pulldown resistors are selected by ENx\_PD bits (in CONFIG register).

---

#### 注

The control of the GPIOx pin cannot be changed from one ENx pin to a different ENx pin because the control is ENx signal edge sensitive. The control from ENx pin to register bit and back to the original ENx pin can be done during operation.

---

### 7.3.9 Digital Signal Filtering

The digital signals have a debounce filtering. The signal/supply is sampled with a clock signal and a counter. This results as an accuracy of one clock period for the debounce window.

**表 7. Digital Signal Filtering**

EVENT	SIGNAL/SUPPLY	RISING EDGE DEBOUNCE TIME	FALLING EDGE DEBOUNCE TIME
Enable/disable/voltage select for Buckx	EN1	3 $\mu$ s <sup>(1)</sup>	3 $\mu$ s <sup>(1)</sup>
Enable/disable/voltage select for Buckx	EN2	3 $\mu$ s <sup>(1)</sup>	3 $\mu$ s <sup>(1)</sup>
Enable/disable/voltage select for Buckx	EN3	3 $\mu$ s <sup>(1)</sup>	3 $\mu$ s <sup>(1)</sup>
VANA UVLO	VANA	20 $\mu$ s (VANA voltage rising)	Immediate (VANA voltage falling)
VANA overvoltage	VANA	20 $\mu$ s (VANA voltage rising)	20 $\mu$ s (VANA voltage falling)
Thermal warning	TDIE_WARN	20 $\mu$ s	20 $\mu$ s
Thermal shutdown	TDIE_SD	20 $\mu$ s	20 $\mu$ s
Current limit	VOUTx_ILIM	20 $\mu$ s	20 $\mu$ s
Overload	FB_B0, FB_B1, FB_B2, FB_F3	1 ms	20 $\mu$ s
Power-Good interrupt	FB_B0, FB_B1, FB_B2, FB_F3	20 $\mu$ s	20 $\mu$ s
PGOOD pin (voltage monitoring)	PGOOD / FB_B0, FB_B1, FB_B2, FB_F3	4-8 $\mu$ s (start-up debounce time during start-up)	4 to 8 $\mu$ s
PGOOD pin (current monitoring)	PGOOD	20 $\mu$ s	20 $\mu$ s

(1) No glitch filtering, only synchronization.

## 7.4 Device Functional Modes

### 7.4.1 Modes of Operation

**SHUTDOWN:** The NRST voltage is below threshold level. All switch, reference, control, and bias circuitry of the LP87524B/J/P-Q1 device are turned off.

**READ OTP:** The main supply voltage VANA is above  $VANA_{UVLO}$  level and NRST voltage is above threshold level. The regulators are disabled and the reference and bias circuitry of the LP87524B/J/P-Q1 are enabled. The OTP bits are loaded to registers.

**STANDBY:** The main supply voltage VANA is above  $VANA_{UVLO}$  level and NRST voltage is above threshold level. The regulators are disabled and the reference, control and bias circuitry of the LP87524B/J/P-Q1 are enabled. All registers can be read or written by the host processor via the system serial interface. The regulators can be enabled if needed.

**ACTIVE:** The main supply voltage VANA is above  $VANA_{UVLO}$  level and NRST voltage is above threshold level. At least one regulated DC-DC converter is enabled. All registers can be read or written by the host processor via the system serial interface.

The operating modes and transitions between the modes are shown in [图 15](#).

Device Functional Modes (接下页)



图 15. Device Operation Modes

## 7.5 Programming

### 7.5.1 I<sup>2</sup>C-Compatible Interface

The I<sup>2</sup>C-compatible synchronous serial interface provides access to the programmable functions and registers on the device. This protocol uses a two-wire interface for bidirectional communications between the devices connected to the bus. The two interface lines are the serial data line (SDA), and the serial clock line (SCL). Every device on the bus is assigned a unique address and acts as either a master or a slave depending on whether it generates or receives the serial clock SCL. The SCL and SDA lines must each have a pullup resistor placed somewhere on the line and remain HIGH even when the bus is idle. Note: CLK pin is not used for serial bus data transfer. The LP87524B/J/P-Q1 supports standard mode (100 kHz), fast mode (400 kHz), fast mode+ (1 MHz), and high-speed mode (3.4 MHz).

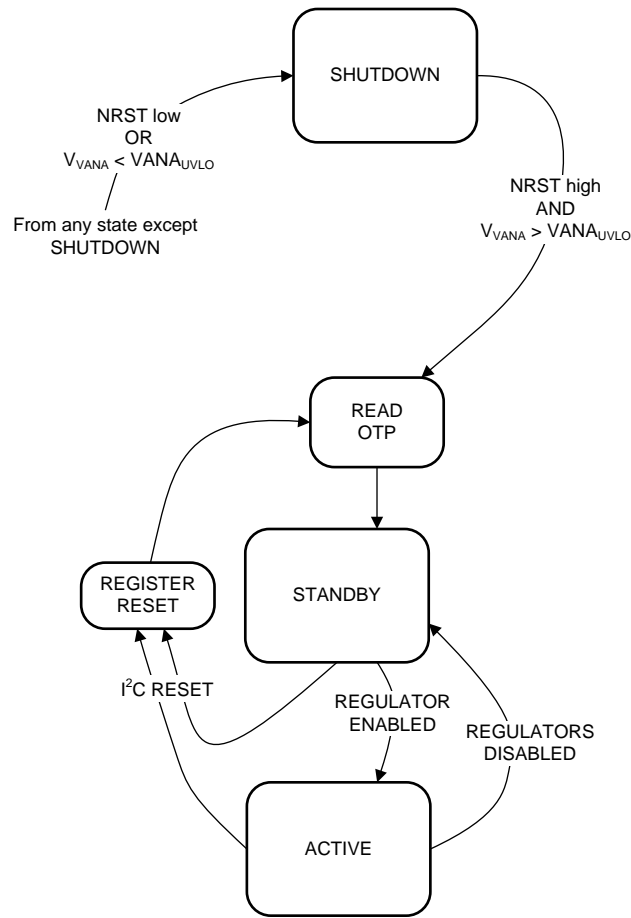
#### 7.5.1.1 Data Validity

The data on the SDA line must be stable during the HIGH period of the clock signal (SCL). In other words, the state of the data line can only be changed when clock signal is LOW.



图 16. Data Validity Diagram

#### 7.5.1.2 Start and Stop Conditions

The LP87524B/J/P-Q1 is controlled via an I<sup>2</sup>C-compatible interface. START and STOP conditions classify the beginning and end of the I<sup>2</sup>C session. A START condition is defined as SDA transitions from HIGH to LOW while SCL is HIGH. A STOP condition is defined as SDA transition from LOW to HIGH while SCL is HIGH. The I<sup>2</sup>C master always generates the START and STOP conditions.

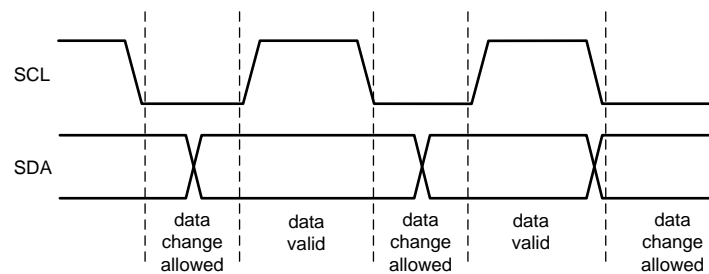

图 17. Start and Stop Sequences

The I<sup>2</sup>C bus is considered busy after a START condition and free after a STOP condition. During data transmission the I<sup>2</sup>C master can generate repeated START conditions. A START and a repeated START condition are equivalent function-wise. The data on SDA must be stable during the HIGH period of the clock signal (SCL). In other words, the state of SDA can only be changed when SCL is LOW. 图 18 shows the SDA and SCL signal timing for the I<sup>2</sup>C-compatible bus. See the 图 1 for timing values.

Programming (接下页)

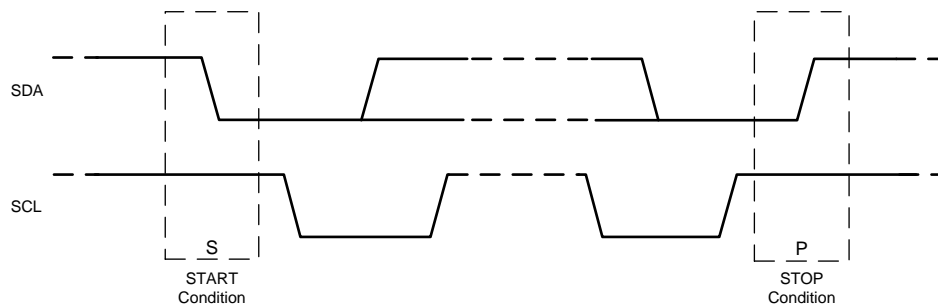

图 18. I<sup>2</sup>C-Compatible Timing

7.5.1.3 Transferring Data

Every byte put on the SDA line must be eight bits long, with the most significant bit (MSB) being transferred first. Each byte of data has to be followed by an acknowledge bit. The acknowledge related clock pulse is generated by the master. The master releases the SDA line (HIGH) during the acknowledge clock pulse. The LP87524B/J/P-Q1 pulls down the SDA line during the 9th clock pulse, signifying an acknowledge. The LP87524B/J/P-Q1 generates an acknowledge after each byte has been received.

There is one exception to the *acknowledge after every byte* rule. When the master is the receiver, it must indicate to the transmitter an end of data by not-acknowledging (*negative acknowledge*) the last byte clocked out of the slave. This *negative acknowledge* still includes the acknowledge clock pulse (generated by the master), but the SDA line is not pulled down.

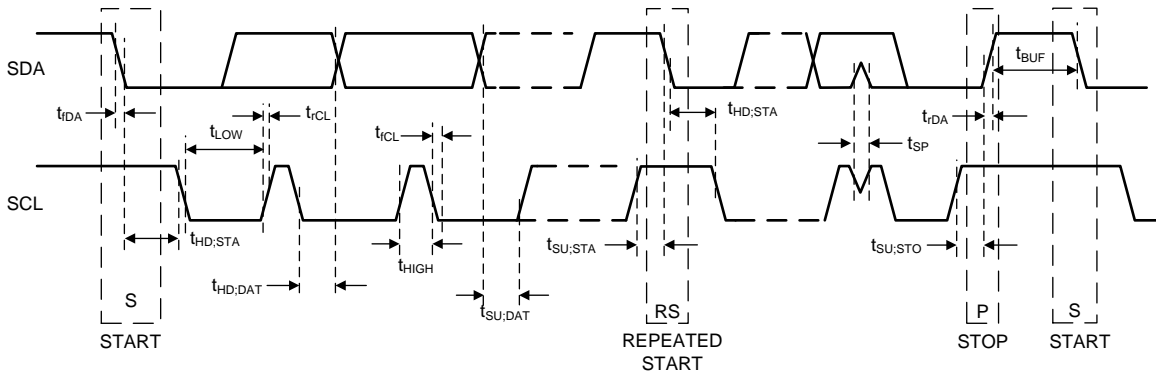
注

If the NRST signal is low during I<sup>2</sup>C communication the LP87524B/J/P-Q1 device does not drive SDA line. The ACK signal and data transfer to the master is disabled at that time.

After the START condition, the bus master sends a chip address. This address is seven bits long followed by an eighth bit which is a data direction bit (READ or WRITE). For the eighth bit, a 0 indicates a WRITE and a 1 indicates a READ. The second byte selects the register to which the data will be written. The third byte contains data to write to the selected register.



图 19. Write Cycle (w = write; SDA = 0), id = Device Address = 0x60 for LP87524B/J/P-Q1

**Programming (接下页)**

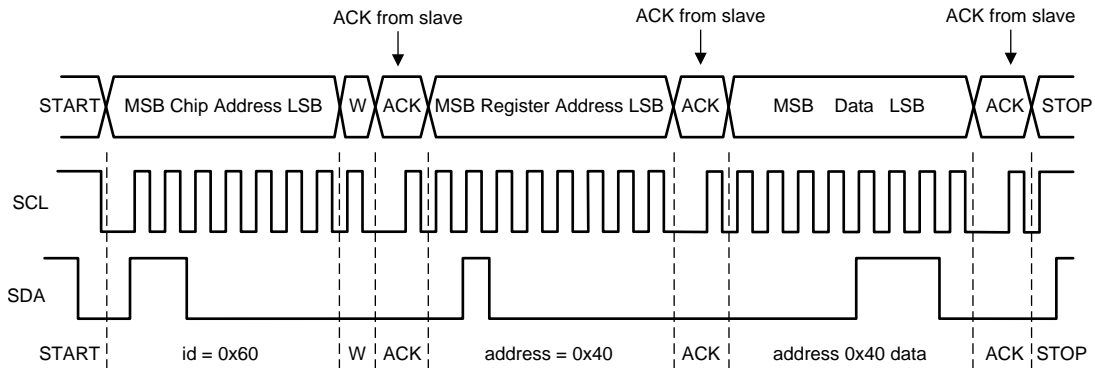
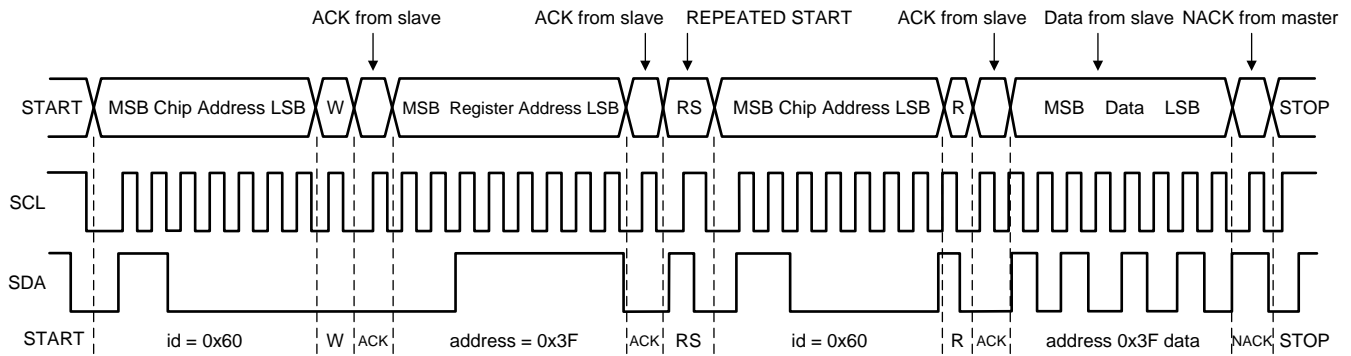

When READ function is to be accomplished, a WRITE function must precede the READ function as shown above.

**图 20. Read Cycle ( r = read; SDA = 1), id = Device Address = 0x60 for LP87524B/J/P-Q1**

**7.5.1.4 I<sup>2</sup>C-Compatible Chip Address**

注

The device address for the LP87524B/J/P-Q1 is 0x60

After the START condition, the I<sup>2</sup>C master sends the 7-bit address followed by an eighth bit, read or write (R/W). R/W = 0 indicates a WRITE and R/W = 1 indicates a READ. The second byte following the device address selects the register address to which the data will be written. The third byte contains the data for the selected register.

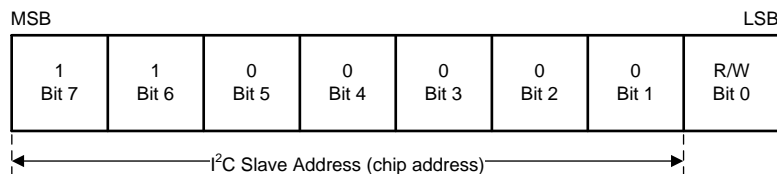

A. Here device address is 1100000Bin = 60Hex.

**图 21. Example Device Address**

**7.5.1.5 Auto-Increment Feature**

The auto-increment feature allows writing several consecutive registers within one transmission. Every time an 8-bit word is sent to the device, the internal address index counter is incremented by one and the next register is written. 表 8 below shows writing sequence to two consecutive registers. Note that auto increment feature does not work for read.

**表 8. Auto-Increment Example**

MASTER ACTION	START	DEVICE ADDRESS = 0x60	WRITE	REGISTER ADDRESS	DATA	DATA	STOP
LP87524B/J/P-Q1			ACK		ACK	ACK	ACK

## 7.6 Register Maps

### 7.6.1 Register Descriptions

The LP87524B/J/P-Q1 is controlled by a set of registers through the I<sup>2</sup>C-compatible interface. The device registers, their addresses, and their abbreviations are listed in [表 9](#). A more detailed description is given in the [OTP\\_REV](#) to [GPIO\\_OUT](#) sections.

The asterisk (\*) marking indicates register bits which are updated from OTP memory during READ OTP state.

**注**

This register map describes the default values read from OTP memory for a device with orderable code of LP87524BRNFRQ1, LP87524JRNFRQ1 and LP87524PRNFRQ1. For other LP8752x versions the default values read from OTP memory can be different.

**表 9. Summary of LP87524B/J/P-Q1 Control Registers**

Addr	Register	Read / Write	D7	D6	D5	D4	D3	D2	D1	D0	
0x01	OTP_REV	R	OTP_ID[7:0]								
0x02	BUCK0_CTRL1	R/W	EN_BUCK0	EN_PIN_CTRL0	BUCK0_EN_PIN_SELECT[1:0]		EN_ROOF_FLOOR0	EN_RDIS0	BUCK0_FPWM	Reserved	
0x04	BUCK1_CTRL1	R/W	EN_BUCK1	EN_PIN_CTRL1	BUCK1_EN_PIN_SELECT[1:0]		EN_ROOF_FLOOR1	EN_RDIS1	BUCK1_FPWM	Reserved	
0x06	BUCK2_CTRL1	R/W	EN_BUCK2	EN_PIN_CTRL2	BUCK2_EN_PIN_SELECT[1:0]		EN_ROOF_FLOOR2	EN_RDIS2	BUCK2_FPWM	Reserved	
0x08	BUCK3_CTRL1	R/W	EN_BUCK3	EN_PIN_CTRL3	BUCK3_EN_PIN_SELECT[1:0]		EN_ROOF_FLOOR3	EN_RDIS3	BUCK3_FPWM	Reserved	
0x0A	BUCK0_VOUT	R/W	BUCK0_VSET[7:0]								
0x0B	BUCK0_FLOOR_VOUT	R/W	BUCK0_FLOOR_VSET[7:0]								
0x0C	BUCK1_VOUT	R/W	BUCK1_VSET[7:0]								
0x0D	BUCK1_FLOOR_VOUT	R/W	BUCK1_FLOOR_VSET[7:0]								
0x0E	BUCK2_VOUT	R/W	BUCK2_VSET[7:0]								
0x0F	BUCK2_FLOOR_VOUT	R/W	BUCK2_FLOOR_VSET[7:0]								
0x10	BUCK3_VOUT	R/W	BUCK3_VSET[7:0]								
0x11	BUCK3_FLOOR_VOUT	R/W	BUCK3_FLOOR_VSET[7:0]								
0x12	BUCK0_DELAY	R/W	BUCK0_SHUTDOWN_DELAY[3:0]				BUCK0_STARTUP_DELAY[3:0]				
0x13	BUCK1_DELAY	R/W	BUCK1_SHUTDOWN_DELAY[3:0]				BUCK1_STARTUP_DELAY[3:0]				
0x14	BUCK2_DELAY	R/W	BUCK2_SHUTDOWN_DELAY[3:0]				BUCK2_STARTUP_DELAY[3:0]				
0x15	BUCK3_DELAY	R/W	BUCK3_SHUTDOWN_DELAY[3:0]				BUCK3_STARTUP_DELAY[3:0]				
0x16	GPIO2_DELAY	R/W	GPIO2_SHUTDOWN_DELAY[3:0]				GPIO2_STARTUP_DELAY[3:0]				
0x17	GPIO3_DELAY	R/W	GPIO3_SHUTDOWN_DELAY[3:0]				GPIO3_STARTUP_DELAY[3:0]				
0x18	RESET	R/W	Reserved								SW_RESET

**Register Maps (接下页)**
**表 9. Summary of LP87524B/J/P-Q1 Control Registers (接下页)**

Addr	Register	Read / Write	D7	D6	D5	D4	D3	D2	D1	D0	
0x19	CONFIG	R/W	DOUBLE_DELAY	CLKIN_PD	Reserved	EN3_PD	TDIE_WARN_LEVEL	EN2_PD	EN1_PD	Reserved	
0x1A	INT_TOP1	R/W	Reserved	INT_BUCK23	INT_BUCK01	NO_SYNC_CLK	TDIE_SD	TDIE_WARN	INT_OVP	I_LOAD_READY	
0x1B	INT_TOP2	R/W	Reserved							RESET_REG	
0x1C	INT_BUCK_0_1	R/W	Reserved	BUCK1_PG_INT	BUCK1_SC_INT	BUCK1_ILIM_INT	Reserved	BUCK0_PG_INT	BUCK0_SC_INT	BUCK0_ILIM_INT	
0x1D	INT_BUCK_2_3	R/W	Reserved	BUCK3_PG_INT	BUCK3_SC_INT	BUCK3_ILIM_INT	Reserved	BUCK2_PG_INT	BUCK2_SC_INT	BUCK2_ILIM_INT	
0x1E	TOP_STAT	R	Reserved			SYNC_CLK_STAT	TDIE_SD_STAT	TDIE_WARN_STAT	OVP_STAT	Reserved	
0x1F	BUCK_0_1_STAT	R	BUCK1_STAT	BUCK1_PG_STAT	Reserved	BUCK1_ILIM_STAT	BUCK0_STAT	BUCK0_PG_STAT	Reserved	BUCK0_ILIM_STAT	
0x20	BUCK_2_3_STAT	R	BUCK3_STAT	BUCK3_PG_STAT	Reserved	BUCK3_ILIM_STAT	BUCK2_STAT	BUCK2_PG_STAT	Reserved	BUCK2_ILIM_STAT	
0x21	TOP_MASK1	R/W	Reserved	Reserved		SYNC_CLK_MASK	Reserved	TDIE_WARN_MASK	Reserved	I_LOAD_READY_MASK	
0x22	TOP_MASK2	R/W	Reserved							RESET_REG_MASK	
0x23	BUCK_0_1_MASK	R/W	Reserved	BUCK1_PG_MASK	Reserved	BUCK1_ILIM_MASK	Reserved	BUCK0_PG_MASK	Reserved	BUCK0_ILIM_MASK	
0x24	BUCK_2_3_MASK	R/W	Reserved	BUCK3_PG_MASK	Reserved	BUCK3_ILIM_MASK	Reserved	BUCK2_PG_MASK	Reserved	BUCK2_ILIM_MASK	
0x25	SEL_I_LOAD	R/W	Reserved							LOAD_CURRENT_BUCK_SELECT[1:0]	
0x26	I_LOAD_2	R	Reserved							BUCK_LOAD_CURRENT[9:8]	
0x27	I_LOAD_1	R	BUCK_LOAD_CURRENT[7:0]								
0x28	PGOOD_CTRL1	R/W	PG3_SEL[1:0]		PG2_SEL[1:0]		PG1_SEL[1:0]		PG0_SEL[1:0]		
0x29	PGOOD_CTRL2	R/W	HALF_DELAY	EN_PG0_NINT	PGOOD_SE_T_DELAY	EN_PGFLT_STAT	Reserved	PGOOD_WINDOW	PGOOD_OD	PGOOD_POL	
0x2A	PGOOD_FLT	R	Reserved				PG3_FLT	PG2_FLT	PG1_FLT	PG0_FLT	
0x2B	PLL_CTRL	R/W	PLL_MODE[1:0]		Reserved	EXT_CLK_FREQ[4:0]					
0x2C	PIN_FUNCTION	R/W	EN_SPREAD_SPEC	EN_PIN_CTL_GPIO3	EN_PIN_SELECT_GPIO3	EN_PIN_CTL_GPIO2	EN_PIN_SELECT_GPIO2	GPIO3_SEL	GPIO2_SEL	GPIO1_SEL	
0x2D	GPIO_CONFIG	R/W	Reserved	GPIO3_OD	GPIO2_OD	GPIO1_OD	Reserved	GPIO3_DIR	GPIO2_DIR	GPIO1_DIR	
0x2E	GPIO_IN	R	Reserved					GPIO3_IN	GPIO2_IN	GPIO1_IN	
0x2F	GPIO_OUT	R/W	Reserved					GPIO3_OUT	GPIO2_OUT	GPIO1_OUT	

### 7.6.1.1 OTP\_REV

Address: 0x01

D7	D6	D5	D4	D3	D2	D1	D0
OTP_ID[7:0]							
Bits	Field	Type	Default	Description			
7:0	OTP_ID[7:0]	R	0x71 for LP87524B, 0x72 for LP87524J, 0x3B for LP87524P *	Identification code of the OTP EPROM version			

### 7.6.1.2 BUCK0\_CTRL1

Address: 0x02

D7	D6	D5	D4	D3	D2	D1	D0
EN_BUCK0	EN_PIN_CTRL 0	BUCK0_EN_PIN_SELECT[1:0]	EN_ROOF_FLOOR0	EN_RDIS0	BUCK0_FPWM	Reserved	

Bits	Field	Type	Default	Description
7	EN_BUCK0	R/W	1 *	Enable Buck0 regulator: 0 - Buck0 regulator is disabled 1 - Buck0 regulator is enabled
6	EN_PIN_CTRL0	R/W	1 *	Enable EN1/2/3 pin control for Buck0: 0 - Only the EN_BUCK0 bit controls Buck0 1 - EN_BUCK0 bit AND ENx pin control Buck0
5:4	BUCK0_EN_PIN_SELECT[1:0]	R/W	0x0*	Enable EN1/2/3 pin control for Buck0: 0x0 - EN_BUCK0 bit AND EN1 pin control Buck0 0x1 - EN_BUCK0 bit AND EN2 pin control Buck0 0x2 - EN_BUCK0 bit AND EN3 pin control Buck0 0x3 - Reserved
3	EN_ROOF_FLOOR0	R/W	0	Enable Roof/Floor control of EN1/2/3 pin if EN_PIN_CTRL0 = 1: 0 - Enable/disable (1/0) control 1 - Roof/floor (1/0) control
2	EN_RDIS0	R/W	1	Enable output discharge resistor when Buck0 is disabled: 0 - Discharge resistor disabled 1 - Discharge resistor enabled
1	BUCK0_FPWM	R/W	0 for LP87524B, LP87524J, 1 for LP87524P *	Forces the Buck0 regulator to operate in PWM mode: 0 - Automatic transitions between PFM and PWM modes (AUTO mode). 1 - Forced to PWM operation
0	Reserved	R/W	0 *	

**7.6.1.3 BUCK1\_CTRL1**

Address: 0x04

D7		D6		D5		D4		D3		D2		D1		D0	
EN_BUCK1		EN_PIN_CTRL 1		BUCK1_EN_PIN_SELECT[1:0]		EN_ROOF_ FLOOR1		EN_RDIS1		BUCK1_FPWM		Reserved			
Bits	Field	Type	Default	Description											
7	EN_BUCK1	R/W	1 *	Enable Buck1 regulator: 0 - Buck1 regulator is disabled 1 - Buck1 regulator is enabled											
6	EN_PIN_CTRL1	R/W	1 *	Enable EN1/2/3 pin control for Buck1: 0 - Only EN_BUCK1 bit controls Buck1 1 - EN_BUCK1 bit AND ENx pin control Buck1											
5:4	BUCK1_EN_PIN_SELECT[1:0]	R/W	0x0*	Enable EN1/2/3 pin control for Buck1: 0x0 - EN_BUCK1 bit AND EN1 pin control Buck1 0x1 - EN_BUCK1 bit AND EN2 pin control Buck1 0x2 - EN_BUCK1 bit AND EN3 pin control Buck1 0x3 - Reserved											
3	EN_ROOF_ FLOOR1	R/W	0	Enable Roof/Floor control of EN1/2/3 pin if EN_PIN_CTRL1 = 1: 0 - Enable/Disable (1/0) control 1 - Roof/Floor (1/0) control											
2	EN_RDIS1	R/W	1	Enable output discharge resistor when Buck1 is disabled: 0 - Discharge resistor disabled 1 - Discharge resistor enabled											
1	BUCK1_FPWM	R/W	0 for LP87524B, LP87524J, 1 for LP87524P *	Forces the Buck1 regulator to operate in PWM mode: 0 - Automatic transitions between PFM and PWM modes (AUTO mode). 1 - Forced to PWM operation											
0	Reserved	R/W	0												

**7.6.1.4 BUCK2\_CTRL1**

Address: 0x06

D7		D6		D5		D4		D3		D2		D1		D0	
EN_BUCK2		EN_PIN_CTRL 2		BUCK2_EN_PIN_SELECT[1:0]		EN_ROOF_ FLOOR2		EN_RDIS2		BUCK2_FPWM		Reserved			
Bits	Field	Type	Default	Description											
7	EN_BUCK2	R/W	1 *	Enable Buck2 regulator: 0 - Buck2 regulator is disabled 1 - Buck2 regulator is enabled											
6	EN_PIN_CTRL2	R/W	1 *	Enable EN1/2/3 pin control for Buck2: 0 - Only EN_BUCK2 bit controls Buck2 1 - EN_BUCK2 bit AND ENx pin control Buck2											
5:4	BUCK2_EN_PIN_SELECT[1:0]	R/W	0x0*	Enable EN1/2/3 pin control for Buck2: 0x0 - EN_BUCK2 bit AND EN1 pin control Buck2 0x1 - EN_BUCK2 bit AND EN2 pin control Buck2 0x2 - EN_BUCK2 bit AND EN3 pin control Buck2 0x3 - Reserved											
3	EN_ROOF_ FLOOR2	R/W	0	Enable Roof/Floor control of EN1/2/3 pin if EN_PIN_CTRL2 = 1: 0 - Enable/Disable (1/0) control 1 - Roof/Floor (1/0) control											
2	EN_RDIS2	R/W	1	Enable output discharge resistor when Buck2 is disabled: 0 - Discharge resistor disabled 1 - Discharge resistor enabled											
1	BUCK2_FPWM	R/W	1 *	Forces the Buck2 regulator to operate in PWM mode: 0 - Automatic transitions between PFM and PWM modes (AUTO mode) 1 - Forced to PWM operation											
0	Reserved	R/W	0 *												

**7.6.1.5 BUCK3\_CTRL1**

Address: 0x08

D7		D6		D5		D4		D3		D2		D1		D0	
EN_BUCK3		EN_PIN_CTRL 3		BUCK3_EN_PIN_SELECT[1:0]		EN_ROOF_ FLOOR3		EN_RDIS3		BUCK3_FPWM		Reserved			
Bits	Field	Type	Default	Description											
7	EN_BUCK3	R/W	1 *	Enable Buck3 regulator: 0 - Buck3 regulator is disabled 1 - Buck3 regulator is enabled											
6	EN_PIN_CTRL3	R/W	1 *	Enable EN1/2/3 pin control for Buck3: 0 - Only EN_BUCK3 bit controls Buck3 1 - EN_BUCK3 bit AND ENx pin control Buck3											
5:4	BUCK3_EN_PIN_SELECT[1:0]	R/W	0x0*	Enable EN1/2/3 pin control for Buck3: 0x0 - EN_BUCK3 bit AND EN1 pin control Buck3 0x1 - EN_BUCK3 bit AND EN2 pin control Buck3 0x2 - EN_BUCK3 bit AND EN3 pin control Buck3 0x3 - Reserved											
3	EN_ROOF_ FLOOR3	R/W	0	Enable Roof/Floor control of EN1/2/3 pin if EN_PIN_CTRL3 = 1: 0 - Enable/Disable (1/0) control 1 - Roof/Floor (1/0) control											
2	EN_RDIS3	R/W	1	Enable output discharge resistor when Buck3 is disabled: 0 - Discharge resistor disabled 1 - Discharge resistor enabled											
1	BUCK3_FPWM	R/W	1 *	Forces the Buck3 regulator to operate in PWM mode: 0 - Automatic transitions between PFM and PWM modes (AUTO mode) 1 - Forced to PWM operation											
0	Reserved	R/W	0												

### 7.6.1.6 BUCK0\_VOUT

Address: 0x0A

D7	D6	D5	D4	D3	D2	D1	D0
BUCK0_VSET[7:0]							
Bits	Field	Type	Default	Description			
7:0	BUCK0_VSET[7:0]	R/W	0xFC for LP87524B, LP87524J, 0x4D for LP87524P *	Sets the output voltage of Buck0 regulator <b>Reserved, DO NOT USE</b> 0x00...0x09 <b>0.6 V - 0.73 V, 10 mV steps</b> 0x0A - 0.6 V ... 0x17 - 0.73 V <b>0.73 V - 1.4 V, 5 mV steps</b> 0x18 - 0.735 V ... 0x9D - 1.4 V <b>1.4 V - 3.36 V, 20 mV steps</b> 0x9E - 1.42 V ... 0xFF - 3.36 V <b>If the input voltage is above 4 V, do not use output voltages below 1.0 V.</b>			

### 7.6.1.7 BUCK0\_FLOOR\_VOUT

Address: 0x0B

D7	D6	D5	D4	D3	D2	D1	D0
BUCK0_FLOOR_VSET[7:0]							
Bits	Field	Type	Default	Description			
7:0	BUCK0_FLOOR_VSET[7:0]	R/W	0x00	Sets the output voltage of Buck0 regulator when floor state is used: <b>Reserved, DO NOT USE</b> 0x00...0x09 <b>0.6 V - 0.73 V, 10 mV steps</b> 0x0A - 0.6 V ... 0x17 - 0.73 V <b>0.73 V - 1.4 V, 5 mV steps</b> 0x18 - 0.735 V ... 0x9D - 1.4 V <b>1.4 V - 3.36 V, 20 mV steps</b> 0x9E - 1.42 V ... 0xFF - 3.36 V <b>If the input voltage is above 4 V, do not use output voltages below 1.0 V.</b>			

### 7.6.1.8 BUCK1\_VOUT

Address: 0x0C

D7	D6	D5	D4	D3	D2	D1	D0
BUCK1_VSET[7:0]							

Bits	Field	Type	Default	Description
7:0	BUCK1_VSET[7:0]	R/W	0x75*	Sets the output voltage of Buck1 regulator: <b>Reserved, DO NOT USE</b> 0x00...0x09 <b>0.6 V - 0.73 V, 10 mV steps</b> 0x0A - 0.6 V ... 0x17 - 0.73 V <b>0.73 V - 1.4 V, 5 mV steps</b> 0x18 - 0.735 V ... 0x9D - 1.4 V <b>1.4 V - 3.36 V, 20 mV steps</b> 0x9E - 1.42 V ... 0xFF - 3.36 V <b>If the input voltage is above 4 V, do not use output voltages below 1.0 V.</b>

### 7.6.1.9 BUCK1\_FLOOR\_VOUT

Address: 0x0D

D7	D6	D5	D4	D3	D2	D1	D0
BUCK1_FLOOR_VSET[7:0]							

Bits	Field	Type	Default	Description
7:0	BUCK1_FLOOR_VSET[7:0]	R/W	0x00	Sets the output voltage of Buck1 regulator when floor state is used: <b>Reserved, DO NOT USE</b> 0x00...0x09 <b>0.6 V - 0.73 V, 10 mV steps</b> 0x0A - 0.6 V ... 0x17 - 0.73 V <b>0.73 V - 1.4 V, 5 mV steps</b> 0x18 - 0.735 V ... 0x9D - 1.4 V <b>1.4 V - 3.36 V, 20 mV steps</b> 0x9E - 1.42 V ... 0xFF - 3.36 V <b>If the input voltage is above 4 V, do not use output voltages below 1.0 V.</b>

### 7.6.1.10 BUCK2\_VOUT

Address: 0x0E

D7	D6	D5	D4	D3	D2	D1	D0
BUCK2_VSET[7:0]							

Bits	Field	Type	Default	Description
7:0	BUCK2_VSET[7:0]	R/W	0xB1 for LP87524B, 0x4D for LP87524J, LP87524P *	Sets the output voltage of Buck2 regulator: <b>Reserved, DO NOT USE</b> 0x00...0x09 <b>0.6 V - 0.73 V, 10 mV steps</b> 0x0A - 0.6V ... 0x17 - 0.73 V <b>0.73 V - 1.4 V, 5 mV steps</b> 0x18 - 0.735 V ... 0x9D - 1.4 V <b>1.4 V - 3.36 V, 20 mV steps</b> 0x9E - 1.42 V ... 0xFF - 3.36 V <b>If the input voltage is above 4 V, do not use output voltages below 1.0 V.</b>

### 7.6.1.11 BUCK2\_FLOOR\_VOUT

Address: 0x0F

D7	D6	D5	D4	D3	D2	D1	D0
BUCK2_FLOOR_VSET[7:0]							

Bits	Field	Type	Default	Description
7:0	BUCK2_FLOOR_VSET[7:0]	R/W	0x00	Sets the output voltage of Buck2 regulator when floor state is used: <b>Reserved, DO NOT USE</b> 0x00...0x09 <b>0.6 V - 0.73 V, 10 mV steps</b> 0x0A - 0.6 V ... 0x17 - 0.73 V <b>0.73 V - 1.4 V, 5 mV steps</b> 0x18 - 0.735 V ... 0x9D - 1.4 V <b>1.4 V - 3.36 V, 20 mV steps</b> 0x9E - 1.42 V ... 0xFF - 3.36 V <b>If the input voltage is above 4 V, do not use output voltages below 1.0 V.</b>

### 7.6.1.12 BUCK3\_VOUT

Address: 0x10

D7	D6	D5	D4	D3	D2	D1	D0
BUCK3_VSET[7:0]							

Bits	Field	Type	Default	Description
7:0	BUCK3_VSET[7:0]	R/W	0xCA for LP87524B, LP87524J, 0xB1 for LP87524P *	Sets the output voltage of Buck3 regulator: <b>Reserved, DO NOT USE</b> 0x00...0x09 <b>0.6 V - 0.73 V, 10 mV steps</b> 0x0A - 0.6 V ... 0x17 - 0.73 V <b>0.73 V - 1.4 V, 5 mV steps</b> 0x18 - 0.735 V ... 0x9D - 1.4 V <b>1.4 V - 3.36 V, 20 mV steps</b> 0x9E - 1.42 V ... 0xFF - 3.36 V <b>If the input voltage is above 4 V, do not use output voltages below 1.0 V.</b>

### 7.6.1.13 BUCK3\_FLOOR\_VOUT

Address: 0x11

D7	D6	D5	D4	D3	D2	D1	D0
BUCK3_FLOOR_VSET[7:0]							

Bits	Field	Type	Default	Description
7:0	BUCK3_FLOOR_VSET[7:0]	R/W	0x00	Sets the output voltage of Buck3 regulator when Floor state is used: <b>Reserved, DO NOT USE</b> 0x00...0x09 <b>0.6 V - 0.73 V, 10 mV steps</b> 0x0A - 0.6 V ... 0x17 - 0.73 V <b>0.73 V - 1.4 V, 5 mV steps</b> 0x18 - 0.735 V ... 0x9D - 1.4 V <b>1.4 V - 3.36 V, 20 mV steps</b> 0x9E - 1.42 V ... 0xFF - 3.36 V <b>If the input voltage is above 4 V, do not use output voltages below 1.0 V.</b>

### 7.6.1.14 BUCK0\_DELAY

Address: 0x12

D7	D6	D5	D4	D3	D2	D1	D0
BUCK0_SHUTDOWN_DELAY[3:0]				BUCK0_STARTUP_DELAY[3:0]			

Bits	Field	Type	Default	Description
7:4	BUCK0_SHUTDOWN_DELAY[3:0]	R/W	0x0 for LP87524B, LP87524J, 0x1 for LP87524P *	Shutdown delay of Buck0 from falling edge of ENx signal (DOUBLE_DELAY = 0 in CONTROL register and HALF_DELAY = 0 in PGOOD_CTRL2 register. See other delay options in 表 4): 0x0 - 0 ms 0x1 - 1 ms ... 0xF - 15 ms
3:0	BUCK0_STARTUP_DELAY[3:0]	R/W	0x5 for LP87524B, LP87524J, 0x3 for LP87524P *	Start-up delay of Buck0 from rising edge of ENx signal (DOUBLE_DELAY = 0 in CONTROL register and HALF_DELAY = 0 in PGOOD_CTRL2 register. See other delay options in 表 4): 0x0 - 0 ms 0x1 - 1 ms ... 0xF - 15 ms

### 7.6.1.15 BUCK1\_DELAY

Address: 0x13

D7	D6	D5	D4	D3	D2	D1	D0
BUCK1_SHUTDOWN_DELAY[3:0]				BUCK1_STARTUP_DELAY[3:0]			
Bits	Field	Type	Default	Description			
7:4	BUCK1_SHUTDOWN_DELAY[3:0]	R/W	0x0 for LP87524B, LP87524J, 0x1 for LP87524P *	Shutdown delay of Buck1 from falling edge of ENx signal (DOUBLE_DELAY = 0 in CONTROL register and HALF_DELAY = 0 in PGOOD_CTRL2 register. See other delay options in 表 4): 0x0 - 0 ms 0x1 - 1 ms ... 0xF - 15 ms			
3:0	BUCK1_STARTUP_DELAY[3:0]	R/W	0x5 for LP87524B, LP87524J, 0x7 for LP87524P *	start-up delay of Buck1 from rising edge of ENx signal (DOUBLE_DELAY = 0 in CONTROL register and HALF_DELAY = 0 in PGOOD_CTRL2 register. See other delay options in 表 4): 0x0 - 0 ms 0x1 - 1 ms ... 0xF - 15 ms			

### 7.6.1.16 BUCK2\_DELAY

Address: 0x14

D7	D6	D5	D4	D3	D2	D1	D0
BUCK2_SHUTDOWN_DELAY[3:0]				BUCK2_STARTUP_DELAY[3:0]			
Bits	Field	Type	Default	Description			
7:4	BUCK2_SHUTDOWN_DELAY[3:0]	R/W	0x0 for LP87524B, LP87524J, 0x1 for LP87524P *	Shutdown delay of Buck2 from falling edge of ENx signal (DOUBLE_DELAY = 0 in CONTROL register and HALF_DELAY = 0 in PGOOD_CTRL2 register. See other delay options in 表 4): 0x0 - 0 ms 0x1 - 1 ms ... 0xF - 15 ms			
3:0	BUCK2_STARTUP_DELAY[3:0]	R/W	0x2 for LP87524B, LP87524J, 0x5 for LP87524P *	start-up delay of Buck2 from rising edge of ENx signal (DOUBLE_DELAY = 0 in CONTROL register and HALF_DELAY = 0 in PGOOD_CTRL2 register. See other delay options in 表 4): 0x0 - 0 ms 0x1 - 1 ms ... 0xF - 15 ms			

### 7.6.1.17 BUCK3\_DELAY

Address: 0x15

D7	D6	D5	D4	D3	D2	D1	D0
BUCK3_SHUTDOWN_DELAY[3:0]				BUCK3_start-up_DELAY[3:0]			
Bits	Field	Type	Default	Description			
7:4	BUCK3_SHUTDOWN_DELAY[3:0]	R/W	0x1*	Shutdown delay of Buck3 from falling edge of ENx signal (DOUBLE_DELAY = 0 in CONTROL register and HALF_DELAY = 0 in PGOOD_CTRL2 register. See other delay options in 表 4): 0x0 - 0 ms 0x1 - 1 ms ... 0xF - 15 ms			
3:0	BUCK3_STARTUP_DELAY[3:0]	R/W	0x0*	Startup delay of Buck3 from rising edge of ENx signal (DOUBLE_DELAY = 0 in CONTROL register and HALF_DELAY = 0 in PGOOD_CTRL2 register. See other delay options in 表 4): 0x0 - 0 ms 0x1 - 1 ms ... 0xF - 15 ms			

### 7.6.1.18 GPIO2\_DELAY

Address: 0x16

D7	D6	D5	D4	D3	D2	D1	D0
GPIO2_SHUTDOWN_DELAY[3:0]				GPIO2_STARTUP_DELAY[3:0]			
Bits	Field	Type	Default	Description			
7:4	GPIO2_SHUTDOWN_DELAY[3:0]	R/W	0x0 for LP87524B, LP87524J, 0x1 for LP87524P*	Delay for GPIO2 falling edge from falling edge of ENx signal (DOUBLE_DELAY = 0 in CONTROL register and HALF_DELAY = 0 in PGOOD_CTRL2 register. See other delay options in 表 4): 0x0 - 0 ms 0x1 - 1 ms ... 0xF - 15 ms			
3:0	GPIO2_STARTUP_DELAY[3:0]	R/W	0x5 for LP87524B, LP87524J, 0x9 for LP87524P*	Delay for GPIO2 rising edge from rising edge of ENx signal (DOUBLE_DELAY = 0 in CONTROL register and HALF_DELAY = 0 in PGOOD_CTRL2 register. See other delay options in 表 4): 0x0 - 0 ms 0x1 - 1 ms ... 0xF - 15 ms			

### 7.6.1.19 GPIO3\_DELAY

Address: 0x17

D7	D6	D5	D4	D3	D2	D1	D0
GPIO3_SHUTDOWN_DELAY[3:0]				GPIO3_STARTUP_DELAY[3:0]			
Bits	Field	Type	Default	Description			
7:4	GPIO3_SHUTDOWN_DELAY[3:0]	R/W	0x0 *	Delay for GPIO3 falling edge from falling edge of ENx signal (DOUBLE_DELAY = 0 in CONTROL register and HALF_DELAY = 0 in PGOOD_CTRL2 register. See other delay options in 表 4): 0x0 - 0 ms 0x1 - 1 ms ... 0xF - 15 ms			

Bits	Field	Type	Default	Description
3:0	GPIO3_STARTUP_DELAY[3:0]	R/W	0x3 for LP87524B, LP87524J, 0xD for LP87524P *	Delay for GPIO3 rising edge from rising edge of ENx signal (DOUBLE_DELAY = 0 in CONTROL register and HALF_DELAY = 0 in PGOOD_CTRL2 register. See other delay options in 表 4): 0x0 - 0 ms 0x1 - 1 ms ... 0xF - 15 ms

### 7.6.1.20 RESET

Address: 0x18

D7	D6	D5	D4	D3	D2	D1	D0
Reserved							SW_RESET

Bits	Field	Type	Default	Description
7:1	Reserved	R/W	0x00	
0	SW_RESET	R/W	0	Software commanded reset. When written to 1, the registers are reset to default values, OTP memory is read, and the I <sup>2</sup> C interface is reset. The bit is automatically cleared.

### 7.6.1.21 CONFIG

Address: 0x19

D7	D6	D5	D4	D3	D2	D1	D0
DOUBLE_DELAY	CLKIN_PD	EN4_PD	EN3_PD	TDIE_WARN_LEVEL	EN2_PD	EN1_PD	Reserved

Bits	Field	Type	Default	Description
7	DOUBLE_DELAY	R/W	0 *	Start-up and shutdown delays from ENx signals: 0 - 0 ms - 15 ms with 1-ms steps 1 - 0 ms - 30 ms with 2-ms steps
6	CLKIN_PD	R/W	1 *	Selects the pulldown resistor on the CLKIN input pin: 0 - Pulldown resistor is disabled. 1 - Pulldown resistor is enabled.
5	Reserved	R/W	0 *	
4	EN3_PD	R/W	0 *	Selects the pulldown resistor on the EN3 (GPIO3) input pin: 0 - Pulldown resistor is disabled. 1 - Pulldown resistor is enabled.
3	TDIE_WARN_LEVEL	R/W	1 for LP87524B, LP87524J, 0 for LP87524P *	Thermal warning threshold level: 0 - 125°C 1 - 137°C.
2	EN2_PD	R/W	0 *	Selects the pull down resistor on the EN2 (GPIO2) input pin: 0 - Pulldown resistor is disabled. 1 - Pull-down resistor is enabled.
1	EN1_PD	R/W	1 *	Selects the pull down resistor on the EN1 (GPIO1) input pin: 0 - Pulldown resistor is disabled. 1 - Pulldown resistor is enabled.
0	Reserved	R/W	0	

### 7.6.1.22 INT\_TOP1

Address: 0x1A

D7	D6	D5	D4	D3	D2	D1	D0
Reserved	INT_BUCK23	INT_BUCK01	NO_SYNC_CLK	TDIE_SD	TDIE_WARN	INT_OVP	I_LOAD_READY

Bits	Field	Type	Default	Description
7	Reserved	R/W	0	
6	INT_BUCK23	R	0	Interrupt indicating that output Buck3 and/or Buck2 have a pending interrupt. The reason for the interrupt is indicated in INT_BUCK_2_3 register. This bit is cleared automatically when INT_BUCK_2_3 register is cleared to 0x00.
5	INT_BUCK01	R	0	Interrupt indicating that output Buck1 and/or Buck0 have a pending interrupt. The reason for the interrupt is indicated in INT_BUCK_0_1 register. This bit is cleared automatically when INT_BUCK_0_1 register is cleared to 0x00.
4	NO_SYNC_CLK	R/W	0	Latched status bit indicating that the external clock is not valid. Write 1 to clear interrupt.
3	TDIE_SD	R/W	0	Latched status bit indicating that the die junction temperature has exceeded the thermal shutdown level. The regulators have been disabled if they were enabled. The regulators cannot be enabled if this bit is active. The actual status of the thermal warning is indicated by TDIE_SD_STAT bit in TOP_STAT register. Write 1 to clear interrupt.
2	TDIE_WARN	R/W	0	Latched status bit indicating that the die junction temperature has exceeded the thermal warning level. The actual status of the thermal warning is indicated by TDIE_WARN_STAT bit in TOP_STAT register. Write 1 to clear interrupt.
1	INT_OVP	R/W	0	Latched status bit indicating that the input voltage has exceeded the overvoltage detection level. The actual status of the overvoltage is indicated by OVP_STAT bit in TOP_STAT register. Write 1 to clear interrupt.
0	I_LOAD_READY	R/W	0	Latched status bit indicating that the load current measurement result is available in I_LOAD_1 and I_LOAD_2 registers. Write 1 to clear interrupt.

### 7.6.1.23 INT\_TOP2

Address: 0x1B

D7	D6	D5	D4	D3	D2	D1	D0
Reserved							RESET_REG

Bits	Field	Type	Default	Description
7:1	Reserved	R/W	0x00	
0	RESET_REG	R/W	0	Latched status bit indicating that either start-up (NRST rising edge) is done, VANA supply voltage has been below undervoltage threshold level, or the host has requested a reset (SW_RESET bit in RESET register). The regulators have been disabled, and registers are reset to default values and the normal start-up procedure is done. Write 1 to clear interrupt.

### 7.6.1.24 INT\_BUCK\_0\_1

Address: 0x1C

D7	D6	D5	D4	D3	D2	D1	D0
Reserved	BUCK1_PG_INT	BUCK1_SC_INT	BUCK1_ILIM_INT	Reserved	BUCK0_PG_INT	BUCK0_SC_INT	BUCK0_ILIM_INT

Bits	Field	Type	Default	Description
7	Reserved	R/W	0	
6	BUCK1_PG_INT	R/W	0	Latched status bit indicating that Buck1 output voltage has reached Power-Good-threshold level. Write 1 to clear.
5	BUCK1_SC_INT	R/W	0	Latched status bit indicating that the Buck1 output voltage has fallen below 0.35-V level during operation or Buck1 output did not reach 0.35-V level in 1 ms from enable. Write 1 to clear.
4	BUCK1_ILIM_INT	R/W	0	Latched status bit indicating that output current limit has been active. Write 1 to clear.
3	Reserved	R/W	0	

Bits	Field	Type	Default	Description
2	BUCK0_PG_INT	R/W	0	Latched status bit indicating that Buck0 output voltage has reached Power-Good-threshold level. Write 1 to clear.
1	BUCK0_SC_INT	R/W	0	Latched status bit indicating that the Buck0 output voltage has fallen below 0.35-V level during operation or Buck0 output did not reach 0.35-V level in 1 ms from enable. Write 1 to clear.
0	BUCK0_ILIM_INT	R/W	0	Latched status bit indicating that output current limit has been active. Write 1 to clear.

### 7.6.1.25 INT\_BUCK\_2\_3

Address: 0x1D

D7	D6	D5	D4	D3	D2	D1	D0
Reserved	BUCK3_PG_INT	BUCK3_SC_INT	BUCK3_ILIM_INT	Reserved	BUCK2_PG_INT	BUCK2_SC_INT	BUCK2_ILIM_INT

Bits	Field	Type	Default	Description
7	Reserved	R/W	0	
6	BUCK3_PG_INT	R/W	0	Latched status bit indicating that Buck3 output voltage has reached Power-Good-threshold level. Write 1 to clear.
5	BUCK3_SC_INT	R/W	0	Latched status bit indicating that the Buck3 output voltage has fallen below 0.35-V level during operation or Buck3 output did not reach 0.35-V level in 1 ms from enable. Write 1 to clear.
4	BUCK3_ILIM_INT	R/W	0	Latched status bit indicating that output current limit has been active. Write 1 to clear.
3	Reserved	R/W	0	
2	BUCK2_PG_INT	R/W	0	Latched status bit indicating that Buck2 output voltage has reached Power-Good-threshold level. Write 1 to clear.
1	BUCK2_SC_INT	R/W	0	Latched status bit indicating that the Buck2 output voltage has fallen below 0.35-V level during operation or Buck2 output did not reach 0.35-V level in 1 ms from enable. Write 1 to clear.
0	BUCK2_ILIM_INT	R/W	0	Latched status bit indicating that output current limit has been active. Write 1 to clear.

### 7.6.1.26 TOP\_STAT

Address: 0x1E

D7	D6	D5	D4	D3	D2	D1	D0
Reserved			SYNC_CLK_STAT	TDIE_SD_STAT	TDIE_WARN_STAT	OVP_STAT	Reserved

Bits	Field	Type	Default	Description
7:5	Reserved	R	0x0	
4	SYNC_CLK_STAT	R	0	Status bit indicating the status of external clock (CLKIN): 0 - External clock frequency is valid 1 - External clock frequency is not valid
3	TDIE_SD_STAT	R	0	Status bit indicating the status of thermal shutdown: 0 - Die temperature below thermal shutdown level 1 - Die temperature above thermal shutdown level
2	TDIE_WARN_STAT	R	0	Status bit indicating the status of thermal warning: 0 - Die temperature below thermal warning level 1 - Die temperature above thermal warning level
1	OVP_STAT	R	0	Status bit indicating the status of input overvoltage monitoring: 0 - Input voltage below overvoltage threshold level 1 - Input voltage above overvoltage threshold level
0	Reserved	R	0	

**7.6.1.27 BUCK\_0\_1\_STAT**

Address: 0x1F

D7		D6		D5		D4		D3		D2		D1		D0	
BUCK1_STAT		BUCK1_PG_STAT		Reserved		BUCK1_ILIM_STAT		BUCK0_STAT		BUCK0_PG_STAT		Reserved		BUCK0_ILIM_STAT	
Bits	Field	Type	Default	Description											
7	BUCK1_STAT	R	0	Status bit indicating the enable/disable status of Buck1: 0 - Buck1 regulator is disabled 1 - Buck1 regulator is enabled											
6	BUCK1_PG_STAT	R	0	Status bit indicating Buck1 output voltage validity (raw status): 0 - Buck1 output is below Power-Good-threshold level 1 - Buck1 output is above Power-Good-threshold level											
5	Reserved	R	0												
4	BUCK1_ILIM_STAT	R	0	Status bit indicating Buck1 current limit status (raw status): 0 - Buck1 output current is below current limit level 1 - Buck1 output current limit is active											
3	BUCK0_STAT	R	0	Status bit indicating the enable/disable status of Buck0: 0 - Buck0 regulator is disabled 1 - Buck0 regulator is enabled											
2	BUCK0_PG_STAT	R	0	Status bit indicating Buck0 output voltage validity (raw status): 0 - Buck0 output is below Power-Good-threshold level 1 - Buck0 output is above Power-Good-threshold level											
1	Reserved	R	0												
0	BUCK0_ILIM_STAT	R	0	Status bit indicating Buck0 current limit status (raw status): 0 - Buck0 output current is below current limit level 1 - Buck0 output current limit is active											

**7.6.1.28 BUCK\_2\_3\_STAT**

Address: 0x20

D7		D6		D5		D4		D3		D2		D1		D0	
BUCK3_STAT		BUCK3_PG_STAT		Reserved		BUCK3_ILIM_STAT		BUCK2_STAT		BUCK2_PG_STAT		Reserved		BUCK2_ILIM_STAT	
Bits	Field	Type	Default	Description											
7	BUCK3_STAT	R	0	Status bit indicating the enable/disable status of Buck3: 0 - Buck3 regulator is disabled 1 - Buck3 regulator is enabled											
6	BUCK3_PG_STAT	R	0	Status bit indicating Buck3 output voltage validity (raw status): 0 - Buck3 output is below Power-Good-threshold level 1 - Buck3 output is above Power-Good-threshold level											
5	Reserved	R	0												
4	BUCK3_ILIM_STAT	R	0	Status bit indicating Buck3 current limit status (raw status): 0 - Buck3 output current is below current limit level 1 - Buck3 output current limit is active											
3	BUCK2_STAT	R	0	Status bit indicating the enable/disable status of Buck2: 0 - Buck2 regulator is disabled 1 - Buck2 regulator is enabled											
2	BUCK2_PG_STAT	R	0	Status bit indicating Buck2 output voltage validity (raw status): 0 - Buck2 output is below Power-Good-threshold level 1 - Buck2 output is above Power-Good-threshold level											
1	Reserved	R	0												
0	BUCK2_ILIM_STAT	R	0	Status bit indicating Buck2 current limit status (raw status): 0 - Buck2 output current is below current limit level 1 - Buck2 output current limit is active											

### 7.6.1.29 TOP\_MASK1

Address: 0x21

D7	D6	D5	D4	D3	D2	D1	D0
Reserved	Reserved		SYNC_CLK_MASK	Reserved	TDIE_WARN_MASK	Reserved	I_LOAD_READY_MASK
Bits	Field	Type	Default	Description			
7	Reserved	R/W	1 *				
6:5	Reserved	R/W	0x0				
4	SYNC_CLK_MASK	R/W	0 *	Masking for external clock detection interrupt (NO_SYNC_CLK in INT_TOP1 register): 0 - Interrupt generated 1 - Interrupt not generated			
3	Reserved	R/W	0				
2	TDIE_WARN_MASK	R/W	0 *	Masking for thermal warning interrupt (TDIE_WARN in INT_TOP1 register): 0 - Interrupt generated 1 - Interrupt not generated This bit does not affect TDIE_WARN_STAT status bit in TOP_STAT register.			
1	Reserved	R/W	0				
0	I_LOAD_READY_MASK	R/W	1 *	Masking for load current measurement ready interrupt (I_LOAD_READY in INT_TOP register). 0 - Interrupt generated 1 - Interrupt not generated			

### 7.6.1.30 TOP\_MASK2

Address: 0x22

D7	D6	D5	D4	D3	D2	D1	D0
Reserved							RESET_REG_MASK
Bits	Field	Type	Default	Description			
7:1	Reserved	R/W	0x00				
0	RESET_REG_MASK	R/W	1 *	Masking for register reset interrupt (RESET_REG in INT_TOP2 register): 0 - Interrupt generated 1 - Interrupt not generated			

### 7.6.1.31 BUCK\_0\_1\_MASK

Address: 0x23

D7	D6	D5	D4	D3	D2	D1	D0
Reserved	BUCK1_PG_MASK	Reserved	BUCK1_ILIM_MASK	Reserved	BUCK0_PG_MASK	Reserved	BUCK0_ILIM_MASK
Bits	Field	Type	Default	Description			
7	Reserved	R/W	0				
6	BUCK1_PG_MASK	R/W	1 *	Masking for Buck1 Power-Good interrupt (BUCK1_PG_INT in INT_BUCK_0_1 register): 0 - Interrupt generated 1 - Interrupt not generated This bit does not affect BUCK1_PG_STAT status bit in BUCK_0_1_STAT register.			
5	Reserved	R	0				
4	BUCK1_ILIM_MASK	R/W	1 *	Masking for Buck1 current-limit-detection interrupt (BUCK1_ILIM_INT in INT_BUCK_0_1 register): 0 - Interrupt generated 1 - Interrupt not generated This bit does not affect BUCK1_ILIM_STAT status bit in BUCK_0_1_STAT register.			
3	Reserved	R/W	0				

Bits	Field	Type	Default	Description
2	BUCK0_PG_MASK	R/W	1 *	Masking for Buck0 Power-Good interrupt (BUCK0_PG_INT in INT_BUCK_0_1 register): 0 - Interrupt generated 1 - Interrupt not generated This bit does not affect BUCK0_PG_STAT status bit in BUCK_0_1_STAT register.
1	Reserved	R	0	
0	BUCK0_ILIM_MASK	R/W	1 *	Masking for Buck0 current-limit-detection interrupt (BUCK0_ILIM_INT in INT_BUCK_0_1 register): 0 - Interrupt generated 1 - Interrupt not generated This bit does not affect BUCK0_ILIM_STAT status bit in BUCK_0_1_STAT register.

### 7.6.1.32 BUCK\_2\_3\_MASK

Address: 0x24

D7	D6	D5	D4	D3	D2	D1	D0
Reserved	BUCK3_PG_MASK	Reserved	BUCK3_ILIM_MASK	Reserved	BUCK2_PG_MASK	Reserved	BUCK2_ILIM_MASK

Bits	Field	Type	Default	Description
7	Reserved	R/W	0	
6	BUCK3_PG_MASK	R/W	1 *	Masking for Buck3 Power-Good interrupt (BUCK3_PG_INT in INT_BUCK_2_3 register): 0 - Interrupt generated 1 - Interrupt not generated This bit does not affect BUCK3_PG_STAT status bit in BUCK_2_3_STAT register.
5	Reserved	R	0	
4	BUCK3_ILIM_MASK	R/W	1 *	Masking for Buck3 current-limit-detection interrupt (BUCK3_ILIM_INT in INT_BUCK_2_3 register): 0 - Interrupt generated 1 - Interrupt not generated This bit does not affect BUCK3_ILIM_STAT status bit in BUCK_2_3_STAT register.
3	Reserved	R/W	0	
2	BUCK2_PG_MASK	R/W	1 *	Masking for Buck2 Power-Good interrupt (BUCK2_PG_INT in INT_BUCK_2_3 register): 0 - Interrupt generated 1 - Interrupt not generated This bit does not affect BUCK2_PG_STAT status bit in BUCK_2_3_STAT register.
1	Reserved	R	0	
0	BUCK2_ILIM_MASK	R/W	1 *	Masking for Buck2 current limit-detection interrupt (BUCK2_ILIM_INT in INT_BUCK_2_3 register): 0 - Interrupt generated 1 - Interrupt not generated This bit does not affect BUCK2_ILIM_STAT status bit in BUCK_2_3_STAT register.

### 7.6.1.33 SEL\_I\_LOAD

Address: 0x25

D7	D6	D5	D4	D3	D2	D1	D0
Reserved						LOAD_CURRENT_BUCK_SELECT[1:0]	

Bits	Field	Type	Default	Description
7:2	Reserved	R/W	0x00	
1:0	LOAD_CURRENT_BUCK_SELECT [1:0]	R/W	0x0	Start the current measurement on the selected regulator: 0x0 - Buck0 0x1 - Buck1 0x2 - Buck2 0x3 - Buck3 A single measurement is started when register is written.

### 7.6.1.34 I\_LOAD\_2

Address: 0x26

D7	D6	D5	D4	D3	D2	D1	D0
Reserved						BUCK_LOAD_CURRENT[9:8]	
Bits	Field	Type	Default	Description			
7:2	Reserved	R	0x00				
1:0	BUCK_LOAD_CURRENT[9:8]	R	0x0	This register describes 3 MSB bits of the average load current on selected regulator with a resolution of 20 mA per LSB and max code corresponding to 20.47-A current.			

### 7.6.1.35 I\_LOAD\_1

Address: 0x27

D7	D6	D5	D4	D3	D2	D1	D0
BUCK_LOAD_CURRENT[7:0]							
Bits	Field	Type	Default	Description			
7:0	BUCK_LOAD_CURRENT[7:0]	R	0x00	This register describes 8 LSB bits of the average load current on selected regulator with a resolution of 20 mA per LSB and max code corresponding to a 20.47-A current.			

### 7.6.1.36 PGOOD\_CTRL1

Address: 0x28

D7	D6	D5	D4	D3	D2	D1	D0
PG3_SEL[1:0]		PG2_SEL[1:0]		PG1_SEL[1:0]		PG0_SEL[1:0]	
Bits	Field	Type	Default	Description			
7:6	PG3_SEL[1:0]	R/W	0x1*	PGOOD signal source control from Buck3 0x0 - Masked 0x1 - Power-Good-threshold voltage 0x2 - Reserved, do not use 0x3 - Power-Good-threshold voltage AND current limit			
5:4	PG2_SEL[1:0]	R/W	0x1*	PGOOD signal source control from Buck2 0x0 - Masked 0x1 - Power-Good-threshold voltage 0x2 - Reserved, do not use 0x3 - Power-Good threshold voltage AND current limit			
3:2	PG1_SEL[1:0]	R/W	0x1*	PGOOD signal source control from Buck1 0x0 - Masked 0x1 - Power-Good-threshold voltage 0x2 - Reserved, do not use 0x3 - Power-Good-threshold voltage AND current limit			
1:0	PG0_SEL[1:0]	R/W	0x1*	PGOOD signal source control from Buck0 0x0 - Masked 0x1 - Power-Good-threshold voltage 0x2 - Reserved, do not use 0x3 - Power-Good-threshold voltage AND current limit			

### 7.6.1.37 PGOOD\_CTRL2

Address: 0x29

D7	D6	D5	D4	D3	D2	D1	D0
HALF_DELAY	EN_PG0_NINT	PGOOD_SET_DELAY	EN_PGFLT_STAT	Reserved	PGOOD_WINDOW	PGOOD_OD	PGOOD_POL

Bits	Field	Type	Default	Description
7	HALF_DELAY	R/W	0 for LP87524B, LP87524J, 1 for LP87524P *	Select the time step for start-up and shutdown delays: 0 - Start-up and shutdown delays have 0.5-ms or 1-ms time steps, based on DOUBLE_DELAY bit in CONFIG register. 1 - Start-up and shutdown delays have 0.32-ms or 0.64-ms time steps, based on DOUBLE_DELAY bit in CONFIG register.
6	EN_PG0_NINT	R/W	0 *	Combine Buck0 PGOOD signal to nINT signal: 0 - Buck0 PGOOD signal not included to nINT signal 1 - Buck0 PGOOD signal included to nINT signal. If nINT OR Buck0 PGOOD is low then nINT signal is low.
5	PGOOD_SET_DELAY	R/W	1 *	Debounce time of output voltage monitoring for PGOOD signal (only when PGOOD signal goes valid): 0 - 4-10 $\mu$ s 1 - 11 ms
4	EN_PGFLT_STAT	R/W	0 *	Operation mode for PGOOD signal: 0 - Indicates live status of monitored voltage outputs. 1 - Indicates status of PGOOD_FLT register, inactive if at least one of PGx_FLT bit is inactive.
3	Reserved	R/W	0	
2	PGOOD_WINDOW	R/W	1 *	Voltage monitoring method for PGOOD signal: 0 - Only undervoltage monitoring 1 - Overvoltage and undervoltage monitoring
1	PGOOD_OD	R/W	1 *	PGOOD signal type: 0 - Push-pull output (VANA level) 1 - Open-drain output
0	PGOOD_POL	R/W	0 *	PGOOD signal polarity: 0 - PGOOD signal high when monitored outputs are valid 1 - PGOOD signal low when monitored outputs are valid

### 7.6.1.38 PGOOD\_FLT

Address: 0x2A

D7	D6	D5	D4	D3	D2	D1	D0
Reserved				PG3_FLT	PG2_FLT	PG1_FLT	PG0_FLT

Bits	Field	Type	Default	Description
7:4	Reserved	R/W	0x0	
3	PG3_FLT	R	0	Source for PGOOD inactive signal: 0 - Buck3 has not set PGOOD signal inactive. 1 - Buck3 has set PGOOD signal inactive. This bit can be cleared by reading this register when Buck3 output is valid.
2	PG2_FLT	R	0	Source for PGOOD inactive signal: 0 - Buck2 has not set PGOOD signal inactive. 1 - Buck2 has set PGOOD signal inactive. This bit can be cleared by reading this register when Buck2 output is valid.
1	PG1_FLT	R	0	Source for PGOOD inactive signal: 0 - Buck1 has not set PGOOD signal inactive. 1 - Buck1 has set PGOOD signal inactive. This bit can be cleared by reading this register when Buck1 output is valid.
0	PG0_FLT	R	0	Source for PGOOD inactive signal: 0 - Buck0 has not set PGOOD signal inactive. 1 - Buck0 has set PGOOD signal inactive. This bit can be cleared by reading this register when Buck0 output is valid.

### 7.6.1.39 PLL\_CTRL

Address: 0x2B

D7	D6	D5	D4	D3	D2	D1	D0
PLL_MODE[1:0]		Reserved			EXT_CLK_FREQ[4:0]		

Bits	Field	Type	Default	Description
7:6	PLL_MODE[1:0]	R/W	0x2*	Selection of external clock and PLL operation: 0x0 - Forced to internal RC oscillator — PLL disabled. 0x1 - PLL is enabled in STANDBY and ACTIVE modes. Automatic external clock use when available, interrupt generated if external clock appears or disappears. 0x2 - PLL is enabled only in ACTIVE mode. Automatic external clock use when available, interrupt generated if external clock appears or disappears. 0x3 - Reserved
5	Reserved	R/W	0	
4:0	EXT_CLK_FREQ[4:0]	R/W	0x01*	Frequency of the external clock (CLKIN): 0x00 - 1 MHz 0x01 - 2 MHz 0x02 - 3 MHz ... 0x16 - 23 MHz 0x17 - 24 MHz 0x18..0x1F - Reserved See <a href="#">Specifications</a> for input clock frequency tolerance.

### 7.6.1.40 PIN\_FUNCTION

Address: 0x2C

D7	D6	D5	D4	D3	D2	D1	D0
EN_SPREAD_SPEC	EN_PIN_CTRL_GPIO3	EN_PIN_SELECT_GPIO3	EN_PIN_CTRL_GPIO2	EN_PIN_SELECT_GPIO2	GPIO3_SEL	GPIO2_SEL	GPIO1_SEL

Bits	Field	Type	Default	Description
7	EN_SPREAD_SPEC	R/W	0 *	Enable spread-spectrum feature: 0 - Disabled 1 - Enabled
6	EN_PIN_CTRL_GPIO3	R/W	1 *	Enable EN1/2 pin control for GPIO3 (GPIO3_SEL=1 AND GPIO3_DIR=1): 0 - Only GPIO3_OUT bit controls GPIO3. 1 - GPIO3_OUT bit AND ENx pin control GPIO3
5	EN_PIN_SELECT_GPIO3	R/W	0 *	Enable EN1/2 pin control for GPIO3: 0 - GPIO3_SEL bit AND EN1 pin control GPIO3 1 - GPIO3_SEL bit AND EN2 pin control GPIO3
4	EN_PIN_CTRL_GPIO2	R/W	1 *	Enable EN1/3 pin control for GPIO2 (GPIO2_SEL=1 AND GPIO2_DIR=1): 0 - Only GPIO2_OUT bit controls GPIO2. 1 - GPIO2_OUT bit AND ENx pin control GPIO2
3	EN_PIN_SELECT_GPIO2	R/W	0 *	Enable EN1/3 pin control for GPIO2: 0 - GPIO2_SEL bit AND EN1 pin control GPIO2 1 - GPIO2_SEL bit AND EN3 pin control GPIO2
2	GPIO3_SEL	R/W	1 *	EN3 pin function: 0 - EN3 1 - GPIO3
1	GPIO2_SEL	R/W	1 *	EN2 pin function: 0 - EN2 1 - GPIO2
0	GPIO1_SEL	R/W	0 *	EN1 pin function: 0 - EN1 1 - GPIO1

### 7.6.1.41 GPIO\_CONFIG

Address: 0x2D

D7	D6	D5	D4	D3	D2	D1	D0
Reserved	GPIO3_OD	GPIO2_OD	GPIO1_OD	Reserved	GPIO3_DIR	GPIO2_DIR	GPIO1_DIR

Bits	Field	Type	Default	Description
7	Reserved	R	0	
6	GPIO3_OD	R/W	1 *	GPIO3 signal type when configured to output: 0 - Push-pull output (VANA level) 1 - Open-drain output
5	GPIO2_OD	R/W	1 *	GPIO2 signal type when configured to output: 0 - Push-pull output (VANA level) 1 - Open-drain output
4	GPIO1_OD	R/W	0 *	GPIO1 signal type when configured to output: 0 - Push-pull output (VANA level) 1 - Open-drain output
3	Reserved	R	0	
2	GPIO3_DIR	R/W	1 *	GPIO3 signal direction: 0 - Input 1 - Output
1	GPIO2_DIR	R/W	1 *	GPIO2 signal direction: 0 - Input 1 - Output
0	GPIO1_DIR	R/W	0 *	GPIO1 signal direction: 0 - Input 1 - Output

### 7.6.1.42 GPIO\_IN

Address: 0x2E

D7	D6	D5	D4	D3	D2	D1	D0
Reserved					GPIO3_IN	GPIO2_IN	GPIO1_IN

Bits	Field	Type	Default	Description
7:3	Reserved	R	0x00	
2	GPIO3_IN	R	0	State of GPIO3 signal: 0 - Logic low level 1 - Logic high level
1	GPIO2_IN	R	0	State of GPIO2 signal: 0 - Logic low level 1 - Logic high level
0	GPIO1_IN	R	0	State of GPIO1 signal: 0 - Logic low level 1 - Logic high level

### 7.6.1.43 GPIO\_OUT

Address: 0x2F

D7	D6	D5	D4	D3	D2	D1	D0
Reserved					GPIO3_OUT	GPIO2_OUT	GPIO1_OUT

Bits	Field	Type	Default	Description
7:3	Reserved	R/W	0x00	
2	GPIO3_OUT	R/W	1 *	Control for GPIO3 signal when configured to GPIO Output: 0 - Logic low level 1 - Logic high level
1	GPIO2_OUT	R/W	1 *	Control for GPIO2 signal when configured to GPIO Output: 0 - Logic low level 1 - Logic high level
0	GPIO1_OUT	R/W	0	Control for GPIO1 signal when configured to GPIO Output: 0 - Logic low level 1 - Logic high level

## 8 Application and Implementation

注

Information in the following applications sections is not part of the TI component specification, and TI does not warrant its accuracy or completeness. TI's customers are responsible for determining suitability of components for their purposes. Customers should validate and test their design implementation to confirm system functionality.

### 8.1 Application Information

The LP87524B/J/P-Q1 is a multi-phase step-down converter with four switcher cores, which are configured to four one-phase regulators configuration.

### 8.2 Typical Application

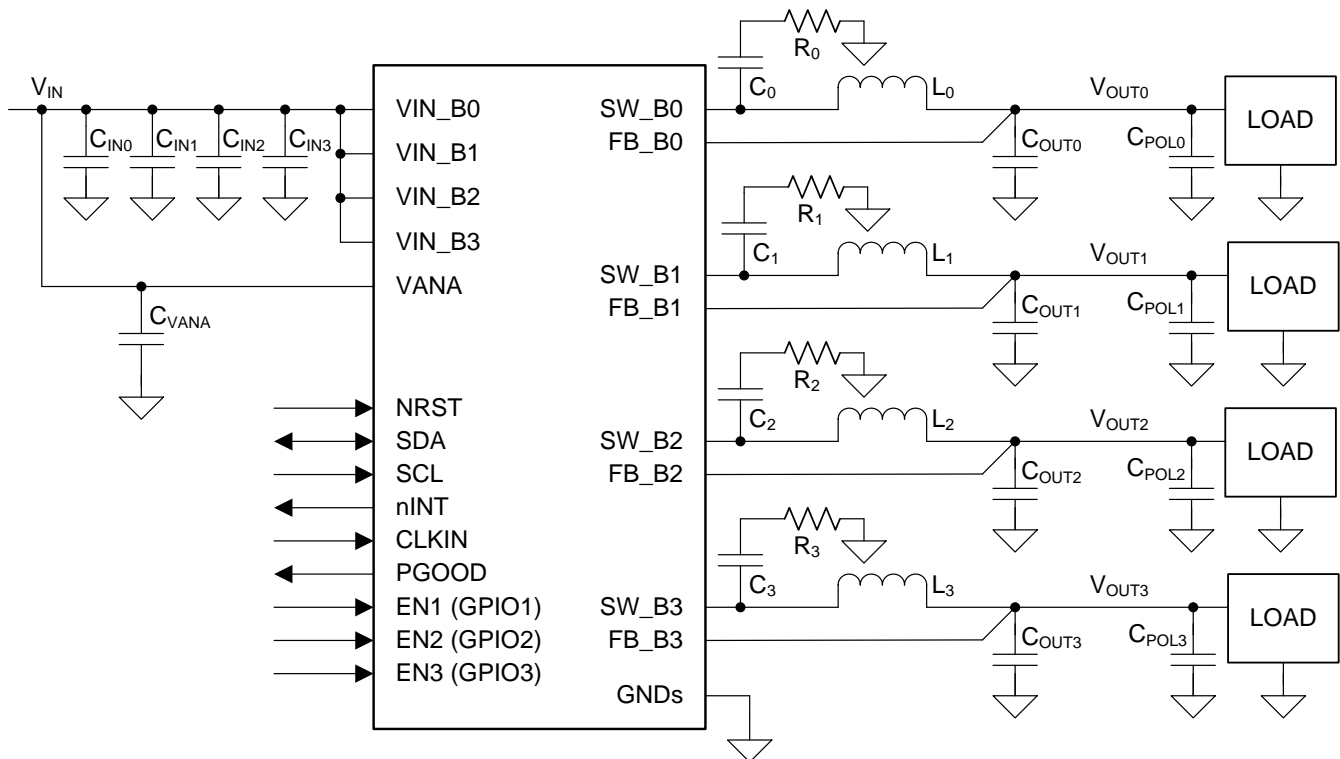

Copyright © 2017, Texas Instruments Incorporated

图 22. Four 1-Phase Configuration

#### 8.2.1 Design Requirements

##### 8.2.1.1 Inductor Selection

The inductors  $L_0$ ,  $L_1$ ,  $L_2$ , and  $L_3$  are shown in the [Typical Application](#). The inductance and DCR of the inductor affects the control loop of the buck regulator. TI recommends using inductors similar to those listed in [表 10](#). Pay attention to the saturation current and temperature rise current of the inductor. Check that the saturation current is higher than the peak current limit and the temperature rise current is higher than the maximum expected rms output current. Minimum effective inductance to ensure good performance is  $0.22 \mu\text{H}$  at maximum peak output current over the operating temperature range. DC resistance of the inductor must be less than  $0.05 \Omega$  for good efficiency at high-current condition. The inductor AC loss (resistance) also affects conversion efficiency. Higher Q factor at switching frequency usually gives better efficiency at light load to middle load. Shielded inductors are preferred as they radiate less noise.

**Typical Application (接下页)**
**表 10. Recommended Inductors**

MANUFACTURER	PART NUMBER	VALUE	DIMENSIONS L × W × H (mm)	RATED DC CURRENT, I <sub>SAT</sub> maximum (typical) / I <sub>TEMP</sub> maximum (typical) (A)	DCR typical / maximum (mΩ)
TOKO	DFE252012PD-R47M	0.47 μH (20%)	2.5 × 2 × 1.2	5.2 (-) / 4 (-) <sup>(1)</sup>	- / 27
Vishay	IHLP1616AB-1A	0.47 μH (20%)	4.1 × 4.5 × 1.2	- (6) / - (6) <sup>(1)</sup>	19 / 21

(1) Operating temperature range is up to 125°C including self temperature rise.

**8.2.1.2 Input Capacitor Selection**

The input capacitors C<sub>INO</sub>, C<sub>IN1</sub>, C<sub>IN2</sub>, and C<sub>IN3</sub> are shown in the [Typical Application](#). A ceramic input bypass capacitor of 10 μF is required for each phase of the regulator. Place the input capacitor as close as possible to the VIN\_Bx pin and PGND\_Bx pin of the device. A larger value or higher voltage rating improves the input voltage filtering. Use X7R type of capacitors, not Y5V or F. DC bias characteristics capacitors must be considered, minimum effective input capacitance to ensure good performance is 1.9 μF per buck input at maximum input voltage including tolerances and ambient temperature range, assuming that there are at least 22 μF of additional capacitance common for all the power input pins on the system power rail. See [表 11](#).

The input filter capacitor supplies current to the high-side FET switch in the first half of each cycle and reduces voltage ripple imposed on the input power source. A ceramic capacitor's low ESR provides the best noise filtering of the input voltage spikes due to this rapidly changing current. Select an input filter capacitor with sufficient ripple current rating. In addition ferrite can be used in front of the input capacitor to reduce the EMI.

**表 11. Recommended Input Capacitors (X7R Dielectric)**

MANUFACTURER	PART NUMBER	VALUE	CASE SIZE	DIMENSIONS L × W × H (mm)	VOLTAGE RATING (V)
Murata	GCM21BR71A106KE22	10 μF (10%)	0805	2 × 1.25 × 1.25	10 V

**8.2.1.3 Output Capacitor Selection**

The output capacitors C<sub>OUT0</sub>, C<sub>OUT1</sub>, C<sub>OUT2</sub>, and C<sub>OUT3</sub> are shown in [Typical Application](#). A ceramic local output capacitor of 22 μF is required per phase. Use ceramic capacitors, X7R or X7T types; do not use Y5V or F. DC bias voltage characteristics of ceramic capacitors must be considered. The output filter capacitor smooths out current flow from the inductor to the load, helps maintain a steady output voltage during transient load changes and reduces output voltage ripple. These capacitors must be selected with sufficient capacitance and sufficiently low ESR and ESL to perform these functions. Minimum effective output capacitance to ensure good performance is 10 μF per phase including the DC voltage roll-off, tolerances, aging and temperature effects.

The output voltage ripple is caused by the charging and discharging of the output capacitor and also due to its R<sub>ESR</sub>. The R<sub>ESR</sub> is frequency dependent (as well as temperature dependent); make sure the value used for selection process is at the switching frequency of the part. See [表 12](#).

POL capacitors (C<sub>POL0</sub>, C<sub>POL1</sub>, C<sub>POL2</sub>, C<sub>POL3</sub>) can be used to improve load transient performance and to decrease the ripple voltage. A higher output capacitance improves the load step behavior and reduces the output voltage ripple as well as decreases the PFM switching frequency. However, output capacitance higher than 100 μF per phase is not necessarily of any benefit. Note that the output capacitor may be the limiting factor in the output voltage ramp and the maximum total output capacitance listed in electrical characteristics must not be exceeded. At shutdown the output voltage is discharged to 0.6 V level using forced-PWM operation. This can increase the input voltage if the load current is small and the output capacitor is large. Below 0.6 V level the output capacitor is discharged by the internal discharge resistor and with large capacitor more time is required to settle V<sub>OUT</sub> down as a consequence of the increased time constant.

**表 12. Recommended Output Capacitors (X7R or X7T Dielectric)**

MANUFACTURER	PART NUMBER	VALUE	CASE SIZE	DIMENSIONS L × W × H (mm)	VOLTAGE RATING (V)
Murata	GCM31CR71A226KE02	22 μF (10%)	1206	3.2 × 1.6 × 1.6	10

### 8.2.1.4 Snubber Components

If the input voltage for the regulators is above 4 V, snubber components are needed at the switching nodes to decrease voltage spiking in the switching node and to improve EMI. The snubber capacitors  $C_0$ ,  $C_1$ ,  $C_2$ , and  $C_3$  and the snubber resistors  $R_0$ ,  $R_1$ ,  $R_2$ , and  $R_3$  are shown in 图 22. The recommended components are shown in 表 13 and these component values give good performance on LP87524B/J/P-Q1 EVM. The optimal resistance and capacitance values finally depend on the PCB layout.

**表 13. Recommended Snubber Components**

MANUFACTURER	PART NUMBER	VALUE	CASE SIZE	DIMENSIONS L × W × H (mm)	VOLTAGE / POWER RATING
Vishay-Dale	CRCW04023R90JNED	3.9 Ω (5%)	0402	1 × 0.5 × 0.4	62 mW
Murata	GCM1555C1H391JA16	390 pF (5%)	0402	1 × 0.5 × 0.5	50 V

### 8.2.1.5 Supply Filtering Components

The VANA input is used to supply analog and digital circuits in the device. See 表 14 for recommended components for VANA input supply filtering.

**表 14. Recommended Supply Filtering Components**

MANUFACTURER	PART NUMBER	VALUE	CASE SIZE	DIMENSIONS L × W × H (mm)	VOLTAGE RATING (V)
Murata	GCM155R71C104KA55	100 nF (10%)	0402	1.0 × 0.5 × 0.5	16
Murata	GCM188R71C104KA37	100 nF (10%)	0603	1.6 × 0.8 × 0.8	16

## 8.2.2 Detailed Design Procedure

The performance of the LP87524B/J/P-Q1 device depends greatly on the care taken in designing the printed circuit board (PCB). The use of low-inductance and low serial-resistance ceramic capacitors is strongly recommended, while proper grounding is crucial. Attention must be given to decoupling the power supplies. Decoupling capacitors must be connected close to the device and between the power and ground pins to support high peak currents being drawn from system power rail during turnon of the switching MOSFETs. Keep input and output traces as short as possible, because trace inductance, resistance, and capacitance can easily become the performance limiting items. The separate power pins VIN\_Bx are not connected together internally. Connect the VIN\_Bx power connections together outside the package using power plane construction.

### 8.2.3 Application Curves

Measurements are done using typical application set up with connections shown in 图 22 (snubber components included when  $V_{IN} > 4\text{ V}$ ). Graphs may not reflect the OTP default settings. Unless otherwise specified:  $V_{IN} = 3.7\text{ V}$ ,  $V_{OUT} = 1\text{ V}$ ,  $V_{(NRST)} = 1.8\text{ V}$ ,  $T_A = 25^\circ\text{C}$ ,  $f_{SW} = 4\text{ MHz}$ ,  $L = 0.47\text{ }\mu\text{H}$  (TOKO DFE252012PD-R47M),  $C_{OUT} = 22\text{ }\mu\text{F}$  / phase, and  $C_{POL} = 22\text{ }\mu\text{F}$  / phase. Measurements are done using connections in the [Typical Application](#).

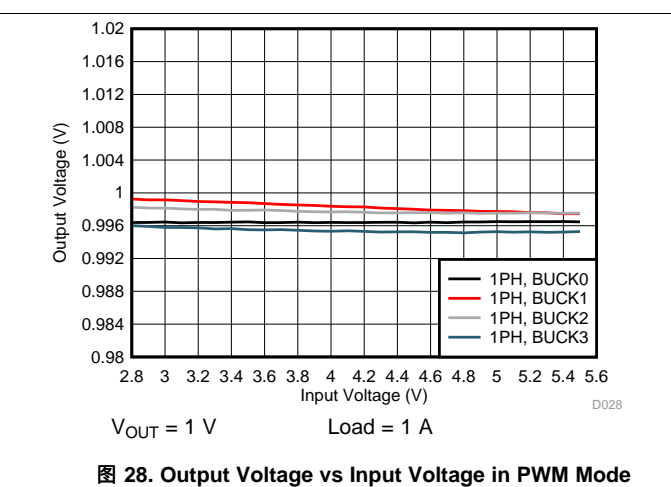
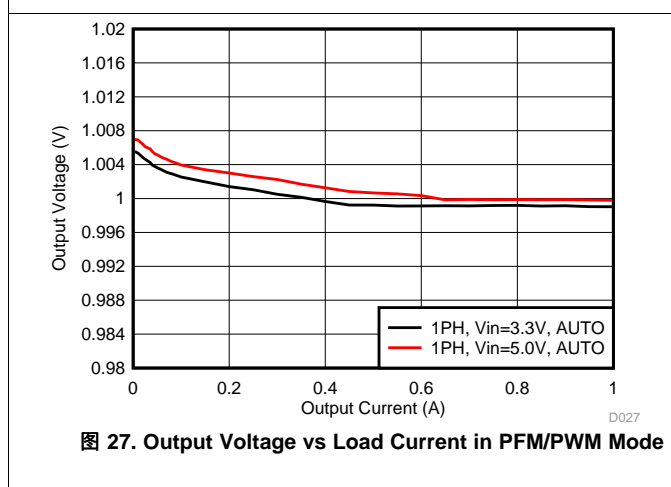
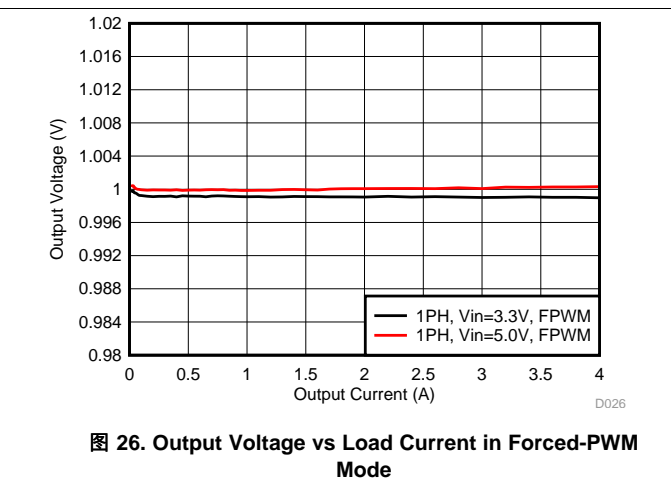
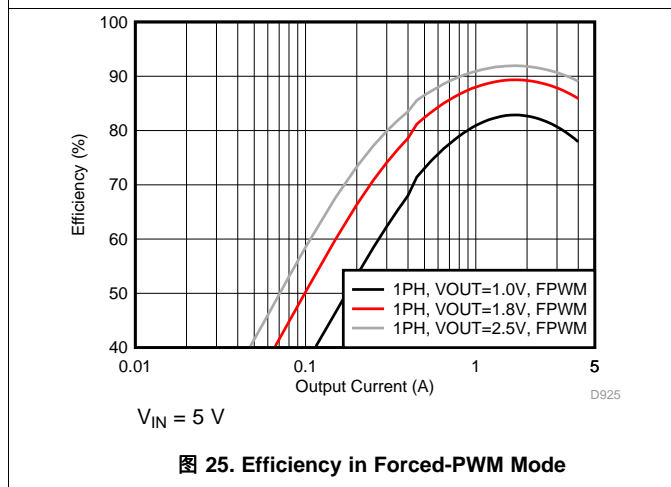
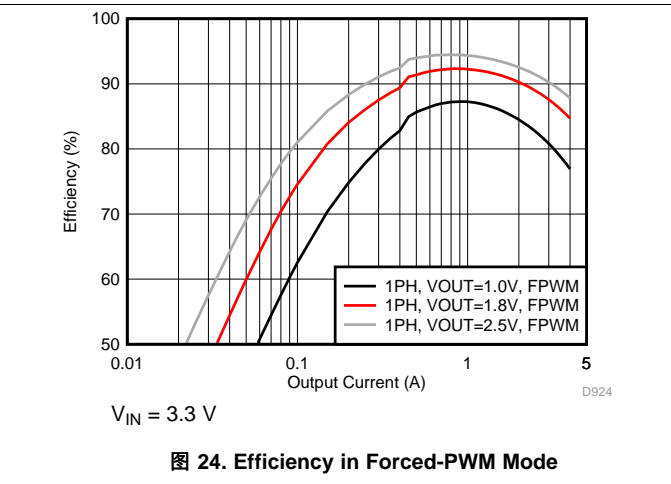
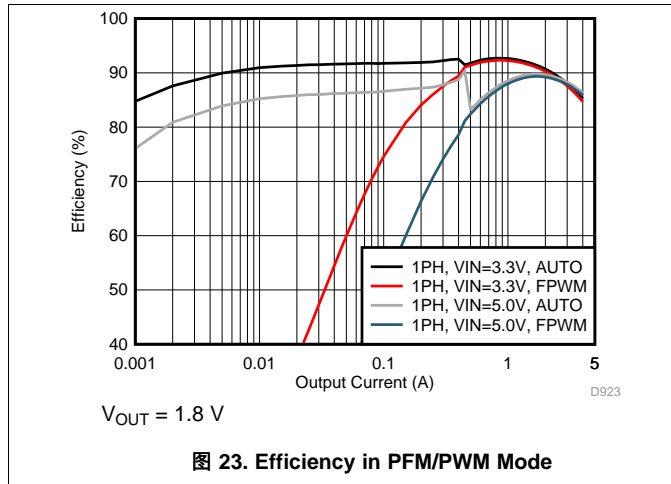



图 29. Output Voltage vs Temperature



图 30. Start-Up With EN1, Forced PWM

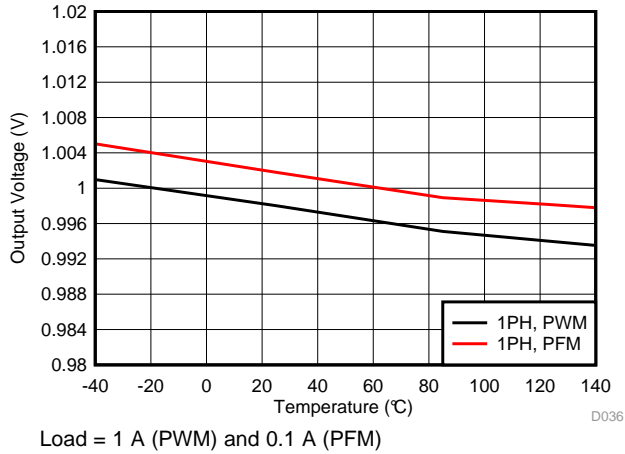

图 31. Start-Up With EN1, Forced PWM (1-Phase Output)

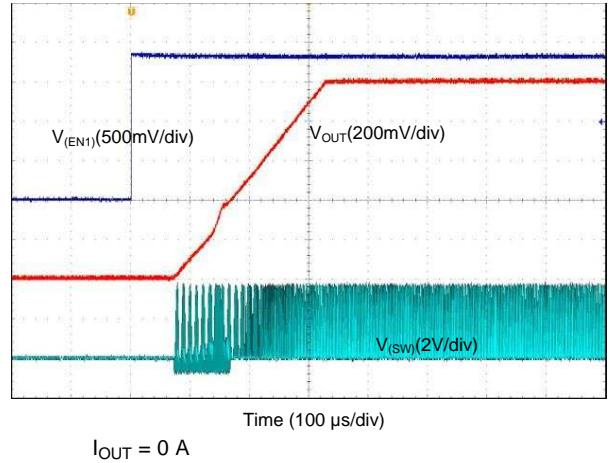

图 32. Shutdown With EN1, Forced PWM (1-Phase Output)

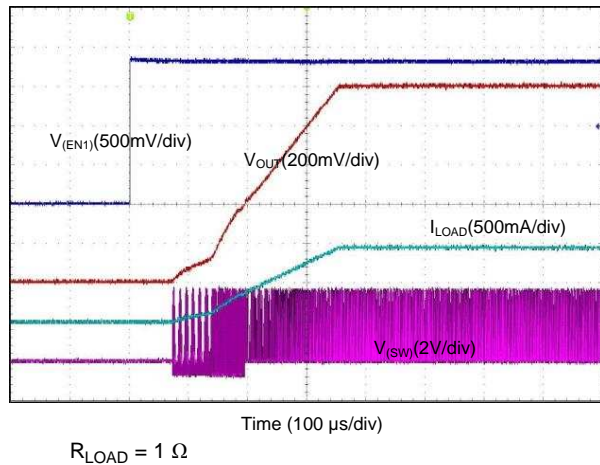

图 33. Output Voltage Ripple, PFM Mode (1-Phase Output)

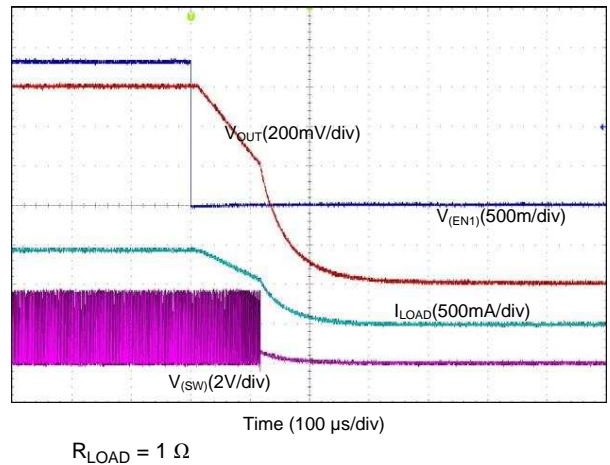

图 34. Output Voltage Ripple, Forced-PWM Mode (1-Phase Output)



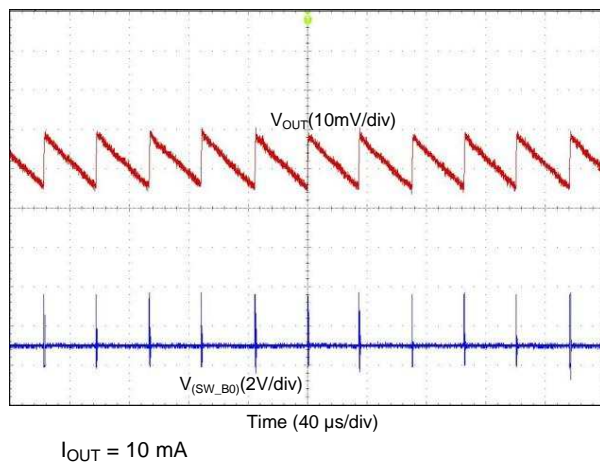

图 41.  $V_{OUT}$  Transition from 1.4 V to 0.6 V

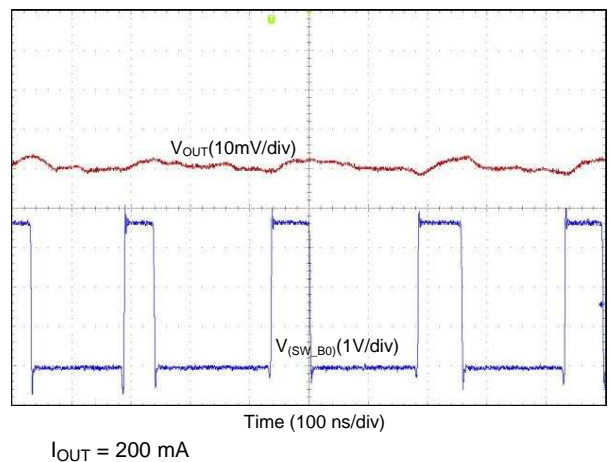
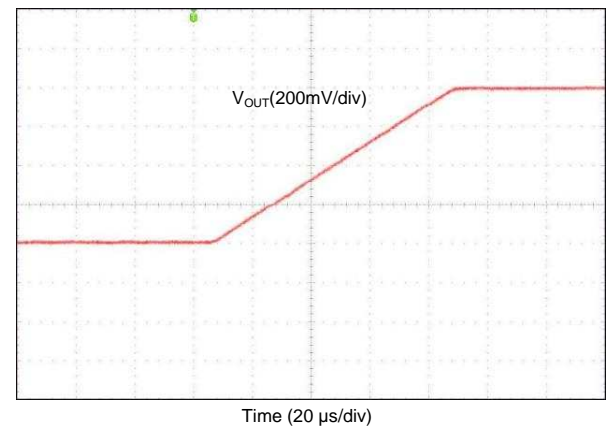
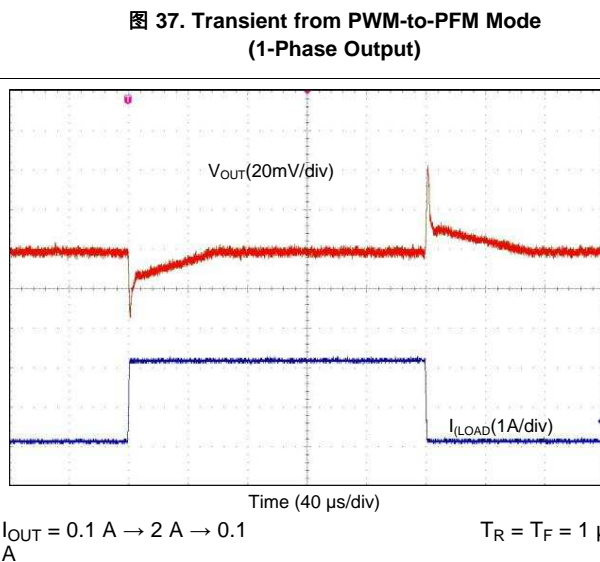
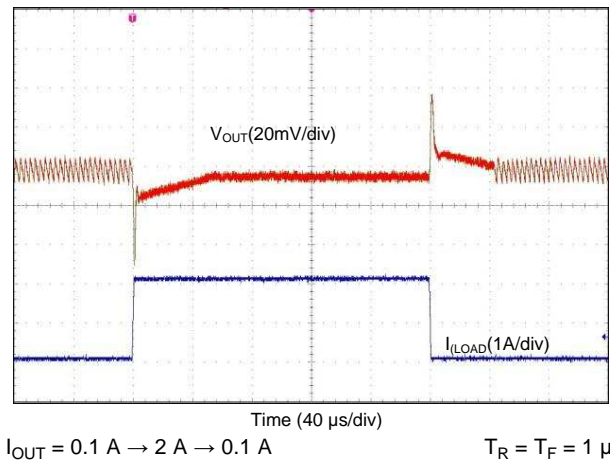
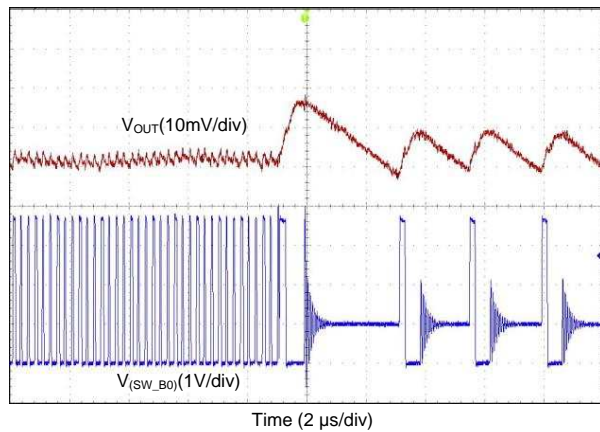
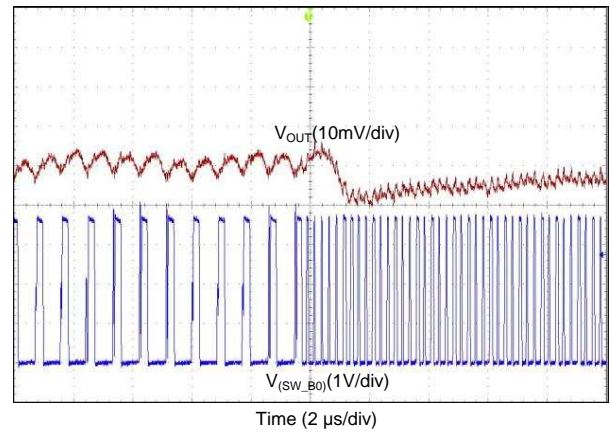
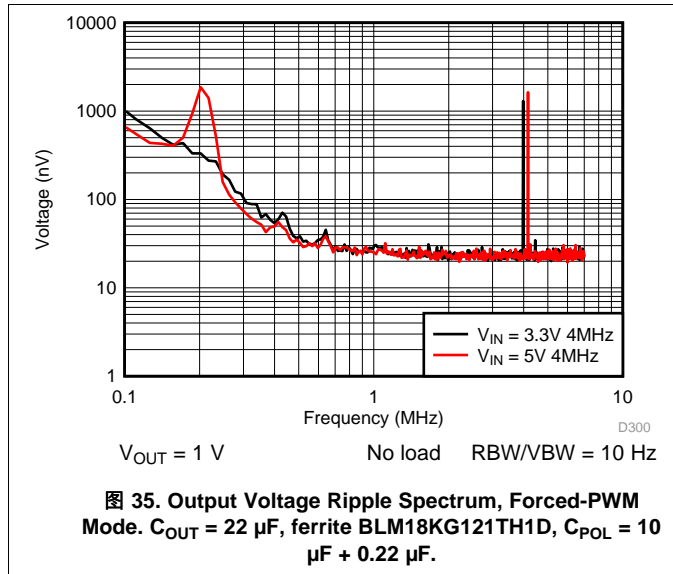

图 42. Start-up With Short on Output (1-Phase Output)

## 9 Power Supply Recommendations

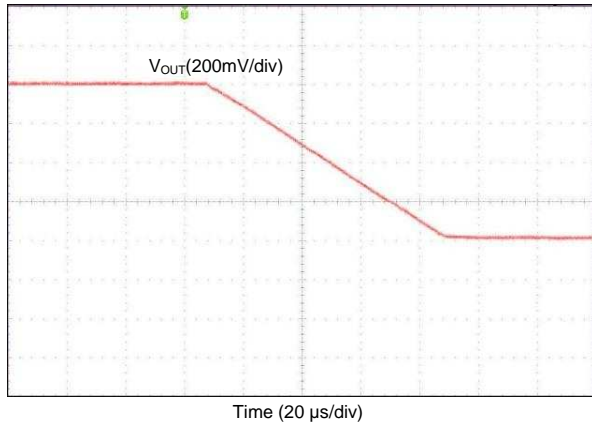
The device is designed to operate from an input voltage supply range from 2.8 V and 5.5 V. This input supply must be well regulated and able to withstand maximum input current and maintain stable voltage without voltage drop even at load transition condition. The resistance of the input supply rail must be low enough that the input current transient does not cause too high drop in the LP87524B/J/P-Q1 supply voltage that can cause false UVLO fault triggering. If the input supply is located more than a few inches from the LP87524B/J/P-Q1 additional bulk capacitance may be required in addition to the ceramic bypass capacitors.

## 10 Layout

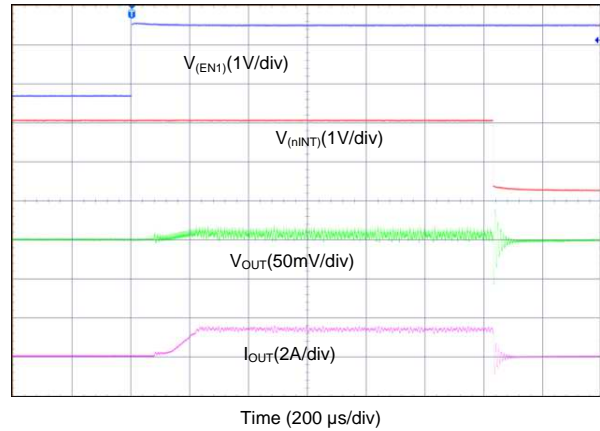
### 10.1 Layout Guidelines

The high frequency and large switching currents of the LP87524B/J/P-Q1 make the choice of layout important. Good power supply results only occur when care is given to proper design and layout. Layout affects noise pickup and generation and can cause a good design to perform with less-than-expected results. With a range of output currents from milliamps to 10 A, good power supply layout is much more difficult than most general PCB design. Use the following steps as a reference to ensure the device is stable and maintains proper voltage and current regulation across its intended operating voltage and current range.

1. Place  $C_{IN}$  as close as possible to the VIN\_Bx pin and the PGND\_Bxx pin. Route the  $V_{IN}$  trace wide and thick to avoid IR drops. The trace between the positive node of the input capacitor and the VIN\_Bx pin(s) of LP87524B/J/P-Q1, as well as the trace between the negative node of the input capacitor and power PGND\_Bxx pin(s), must be kept as short as possible. The input capacitance provides a low-impedance voltage source for the switching converter. The inductance of the connection is the most important parameter of a local decoupling capacitor — parasitic inductance on these traces must be kept as small as possible for proper device operation. The parasitic inductance can be reduced by using a ground plane as close as possible to top layer by using thin dielectric layer between top layer and ground plane.
2. The output filter, consisting of COUT and L, converts the switching signal at SW\_Bx to the noiseless output voltage. It must be placed as close as possible to the device keeping the switch node small, for best EMI behavior. Route the traces between the LP87524B/J/P-Q1 output capacitors and the load direct and wide to avoid losses due to the IR drop.
3. Input for analog blocks (VANA and AGND) must be isolated from noisy signals. Connect VANA directly to a quiet system voltage node and AGND to a quiet ground point where no IR drop occurs. Place the decoupling capacitor as close as possible to the VANA pin.
4. If the processor load supports remote voltage sensing, connect the feedback pins FB\_Bx of the LP87524B/J/P-Q1 device to the respective sense pins on the processor. The sense lines are susceptible to noise. They must be kept away from noisy signals such as PGND\_Bxx, VIN\_Bx, and SW\_Bx, as well as high bandwidth signals such as the I<sup>2</sup>C. Avoid both capacitive and inductive coupling by keeping the sense lines short, direct, and close to each other. Run the lines in a quiet layer. Isolate them from noisy signals by a voltage or ground plane if possible. If series resistors are used for load current measurement, place them after connection of the voltage feedback.
5. PGND\_Bxx, VIN\_Bx and SW\_Bx must be routed on thick layers. They must not surround inner signal layers, which are not able to withstand interference from noisy PGND\_Bxx, VIN\_Bx and SW\_Bx.
6. If the input voltage is above 4 V, place snubber components (capacitor and resistor) between SW\_Bx and ground on all four phases. The components can be also placed to the other side of the board if there are area limitations and the routing traces can be kept short.

Due to the small package of this converter and the overall small solution size, the thermal performance of the PCB layout is important. Many system-dependent parameters such as thermal coupling, airflow, added heat sinks and convection surfaces, and the presence of other heat-generating components affect the power dissipation limits of a given component. Proper PCB layout, focusing on thermal performance, results in lower die temperatures. Wide and thick power traces come with the ability to sink dissipated heat. This can be improved further on multi-layer PCB designs with vias to different planes. This results in reduced junction-to-ambient ( $R_{\theta JA}$ ) and junction-to-board ( $R_{\theta JB}$ ) thermal resistances and thereby reduces the device junction temperature,  $T_J$ . TI strongly recommends to perform of a careful system-level 2D or full 3D dynamic thermal analysis at the beginning product design process, by using a thermal modeling analysis software.

## 10.2 Layout Example



图 43. LP87524B/J/P-Q1 Board Layout

The output voltage rails are shorted together based on the configuration as shown in [Typical Application](#).

## 11 器件和文档支持

### 11.1 器件支持

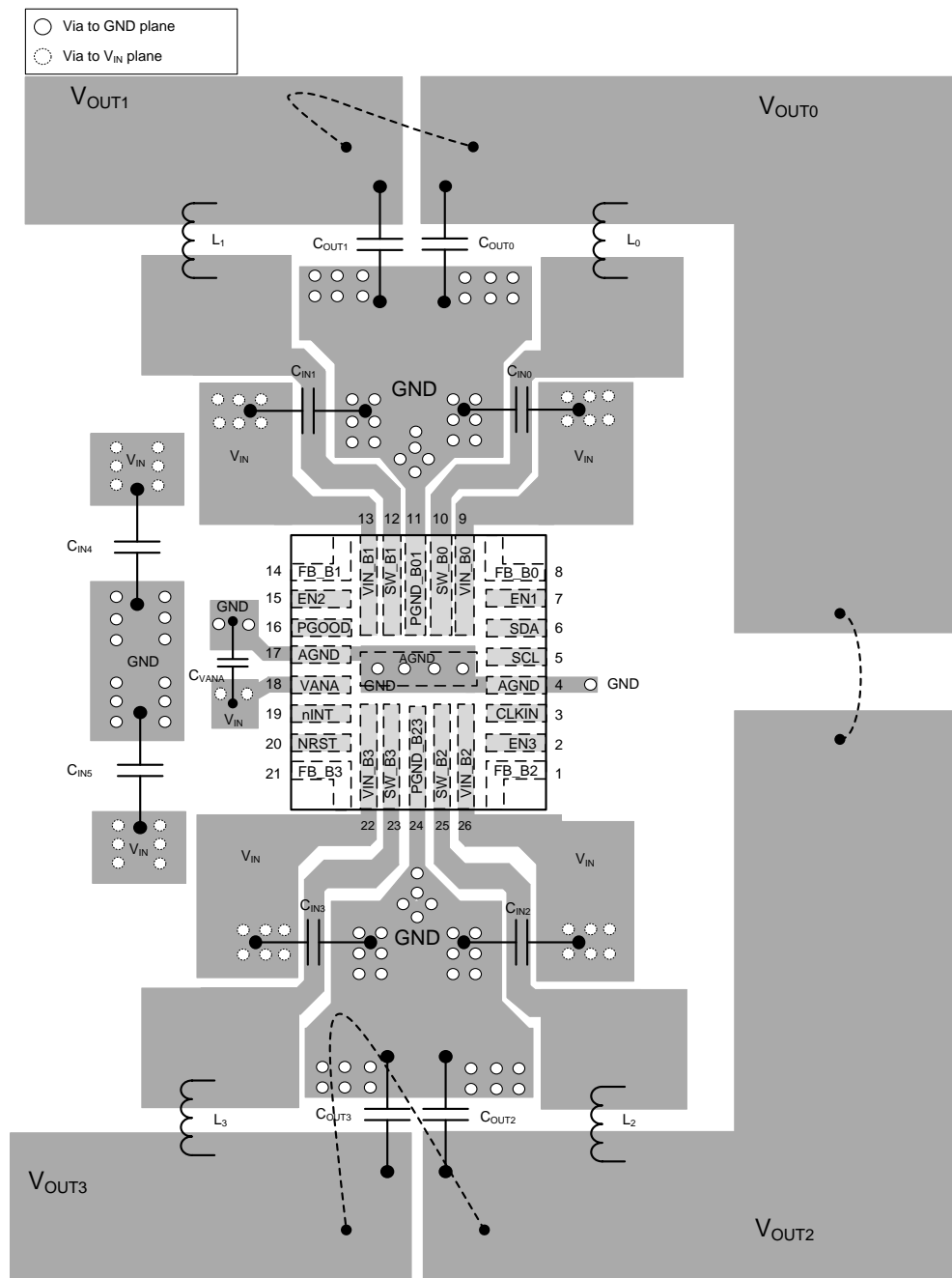
#### 11.1.1 第三方产品免责声明

TI 发布的与第三方产品或服务有关的信息，不能构成与此类产品或服务或保修的适用性有关的认可，不能构成此类产品或服务单独或与任何 TI 产品或服务一起的表示或认可。

#### 11.2 接收文档更新通知

要接收文档更新通知，请导航至 [TI.com.cn](http://TI.com.cn) 上的器件产品文件夹。单击右上角的 *通知我* 进行注册，即可每周接收产品信息更改摘要。有关更改的详细信息，请查看任何已修订文档中包含的修订历史记录。

### 11.3 社区资源

下列链接提供到 TI 社区资源的连接。链接的内容由各个分销商“按照原样”提供。这些内容并不构成 TI 技术规范，并且不一定反映 TI 的观点；请参阅 TI 的 [《使用条款》](#)。

**TI E2E™ 在线社区** *TI 的工程师对工程师 (E2E) 社区*。此社区的创建目的在于促进工程师之间的协作。在 [e2e.ti.com](http://e2e.ti.com) 中，您可以咨询问题、分享知识、拓展思路并与同行工程师一道帮助解决问题。

**设计支持** *TI 参考设计支持* 可帮助您快速查找有帮助的 E2E 论坛、设计支持工具以及技术支持的联系信息。

### 11.4 商标

E2E is a trademark of Texas Instruments.

All other trademarks are the property of their respective owners.

### 11.5 静电放电警告



这些装置包含有限的内置 ESD 保护。存储或装卸时，应将导线一起截短或将装置放置于导电泡棉中，以防止 MOS 门极遭受静电损伤。

### 11.6 术语表

**SLYZ022** — *TI 术语表*。

这份术语表列出并解释术语、缩写和定义。

## 12 机械、封装和可订购信息

以下页面包含机械、封装和可订购信息。这些信息是指定器件的最新可用数据。数据如有变更，恕不另行通知，且不会对此文档进行修订。如需获取此数据表的浏览器版本，请查阅左侧的导航栏。



**PACKAGE OUTLINE**

**RNF0026C**

**VQFN-HR - 0.9 mm max height**

PLASTIC QUAD FLATPACK - NO LEAD

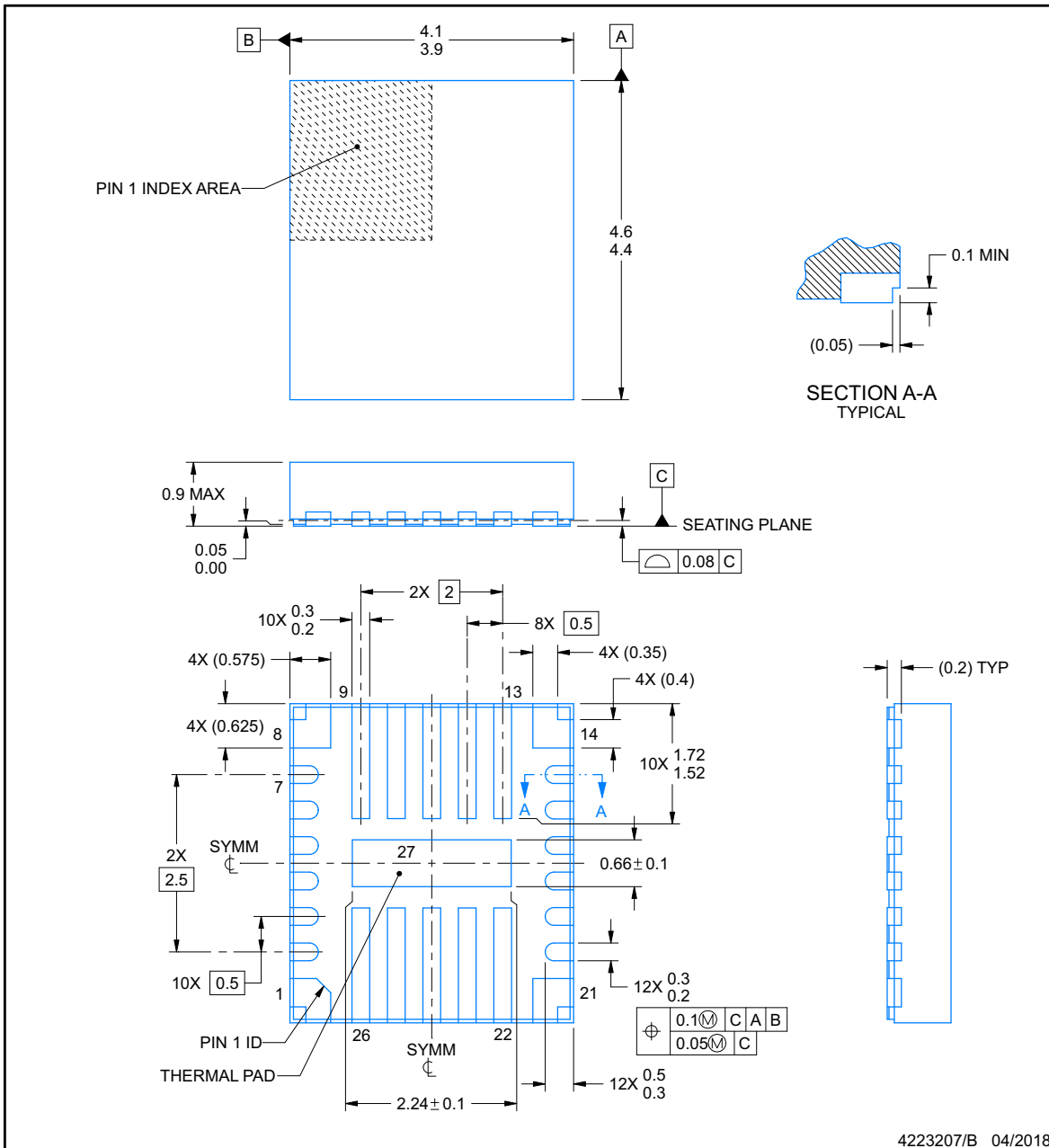

**NOTES:**

1. All linear dimensions are in millimeters. Any dimensions in parenthesis are for reference only. Dimensioning and tolerancing per ASME Y14.5M.
2. This drawing is subject to change without notice.
3. The package thermal pad must be soldered to the printed circuit board for thermal and mechanical performance.

**EXAMPLE BOARD LAYOUT**

**RNF0026C**

**VQFN-HR - 0.9 mm max height**

PLASTIC QUAD FLATPACK - NO LEAD

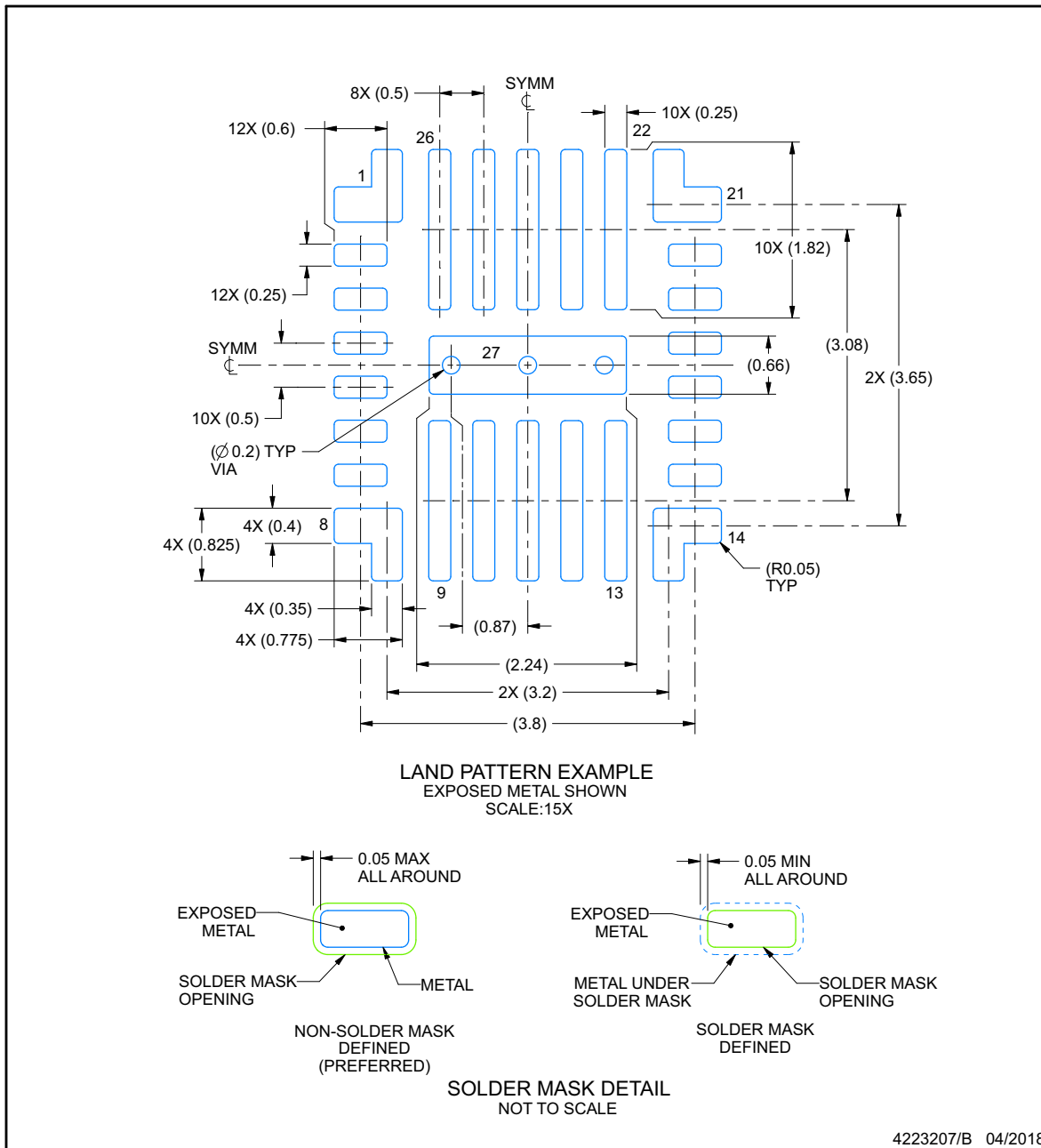

NOTES: (continued)

4. This package is designed to be soldered to a thermal pad on the board. For more information, see Texas Instruments literature number SLUA271 ([www.ti.com/lit/sluea271](http://www.ti.com/lit/sluea271)).
5. Vias are optional depending on application, refer to device data sheet. If any vias are implemented, refer to their locations shown on this view. It is recommended that vias under paste be filled, plugged or tented.

**EXAMPLE STENCIL DESIGN**

**RNF0026C**

**VQFN-HR - 0.9 mm max height**

PLASTIC QUAD FLATPACK - NO LEAD

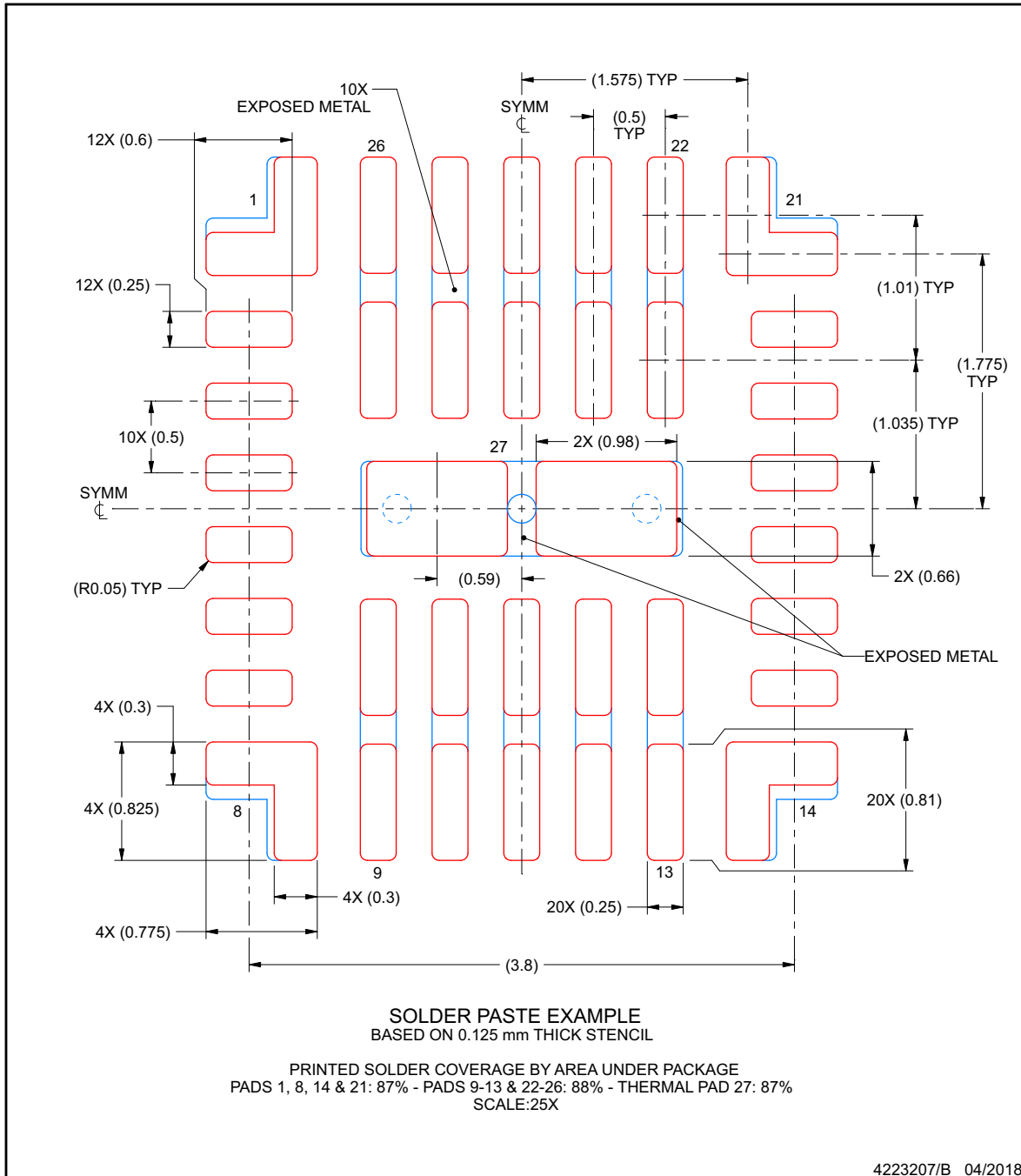

NOTES: (continued)

6. For alternate stencil design recommendations, see IPC-7525 or board assembly site preference.

## 重要声明和免责声明

TI 均以“原样”提供技术性及其可靠性数据（包括数据表）、设计资源（包括参考设计）、应用或其他设计建议、网络工具、安全信息和其他资源，不保证其中不含任何瑕疵，且不做任何明示或暗示的担保，包括但不限于对适销性、适合某特定用途或不侵犯任何第三方知识产权的暗示担保。

所述资源可供专业开发人员应用TI 产品进行设计使用。您将对以下行为独自承担全部责任：(1) 针对您的应用选择合适的TI 产品；(2) 设计、验证并测试您的应用；(3) 确保您的应用满足相应标准以及任何其他安全、安保或其他要求。所述资源如有变更，恕不另行通知。TI 对您使用所述资源的授权仅限于开发资源所涉及TI 产品的相关应用。除此之外不得复制或展示所述资源，也不提供其它TI 或任何第三方的知识产权授权许可。如因使用所述资源而产生任何索赔、赔偿、成本、损失及债务等，TI 对此概不负责，并且您须赔偿由此对TI 及其代表造成的损害。

TI 所提供产品均受TI 的销售条款 (<http://www.ti.com.cn/zh-cn/legal/termsofsale.html>) 以及ti.com.cn上或随附TI产品提供的其他可适用条款的约束。TI提供所述资源并不扩展或以其他方式更改TI 针对TI 产品所发布的可适用的担保范围或担保免责声明。

邮寄地址：上海市浦东新区世纪大道 1568 号中建大厦 32 楼，邮政编码：200122  
Copyright © 2019 德州仪器半导体技术（上海）有限公司

**PACKAGING INFORMATION**

Orderable Device	Status (1)	Package Type	Package Drawing	Pins	Package Qty	Eco Plan (2)	Lead finish/ Ball material (6)	MSL Peak Temp (3)	Op Temp (°C)	Device Marking (4/5)	Samples
LP87524BRNFRQ1	ACTIVE	VQFN-HR	RNF	26	3000	RoHS-Exempt & Green	SN	Level-1-260C-UNLIM	-40 to 125	LP8752 4B-Q1	<a href="#">Samples</a>
LP87524BRNFTQ1	ACTIVE	VQFN-HR	RNF	26	250	RoHS-Exempt & Green	SN	Level-1-260C-UNLIM	-40 to 125	LP8752 4B-Q1	<a href="#">Samples</a>
LP87524JRNFRQ1	ACTIVE	VQFN-HR	RNF	26	3000	RoHS-Exempt & Green	SN	Level-1-260C-UNLIM	-40 to 125	LP8752 4J-Q1	<a href="#">Samples</a>
LP87524JRNFTQ1	ACTIVE	VQFN-HR	RNF	26	250	RoHS-Exempt & Green	SN	Level-1-260C-UNLIM	-40 to 125	LP8752 4J-Q1	<a href="#">Samples</a>
LP87524PRNFRQ1	ACTIVE	VQFN-HR	RNF	26	3000	RoHS-Exempt & Green	SN	Level-1-260C-UNLIM	-40 to 125	LP8752 4P-Q1	<a href="#">Samples</a>
LP87524PRNFTQ1	ACTIVE	VQFN-HR	RNF	26	250	RoHS-Exempt & Green	SN	Level-1-260C-UNLIM	-40 to 125	LP8752 4P-Q1	<a href="#">Samples</a>

(1) The marketing status values are defined as follows:

**ACTIVE:** Product device recommended for new designs.

**LIFEBUY:** TI has announced that the device will be discontinued, and a lifetime-buy period is in effect.

**NRND:** Not recommended for new designs. Device is in production to support existing customers, but TI does not recommend using this part in a new design.

**PREVIEW:** Device has been announced but is not in production. Samples may or may not be available.

**OBSELETE:** TI has discontinued the production of the device.

(2) **RoHS:** TI defines "RoHS" to mean semiconductor products that are compliant with the current EU RoHS requirements for all 10 RoHS substances, including the requirement that RoHS substance do not exceed 0.1% by weight in homogeneous materials. Where designed to be soldered at high temperatures, "RoHS" products are suitable for use in specified lead-free processes. TI may reference these types of products as "Pb-Free".

**RoHS Exempt:** TI defines "RoHS Exempt" to mean products that contain lead but are compliant with EU RoHS pursuant to a specific EU RoHS exemption.

**Green:** TI defines "Green" to mean the content of Chlorine (Cl) and Bromine (Br) based flame retardants meet JS709B low halogen requirements of <=1000ppm threshold. Antimony trioxide based flame retardants must also meet the <=1000ppm threshold requirement.

(3) MSL, Peak Temp. - The Moisture Sensitivity Level rating according to the JEDEC industry standard classifications, and peak solder temperature.

(4) There may be additional marking, which relates to the logo, the lot trace code information, or the environmental category on the device.

(5) Multiple Device Markings will be inside parentheses. Only one Device Marking contained in parentheses and separated by a "~" will appear on a device. If a line is indented then it is a continuation of the previous line and the two combined represent the entire Device Marking for that device.

<sup>(6)</sup> Lead finish/Ball material - Orderable Devices may have multiple material finish options. Finish options are separated by a vertical ruled line. Lead finish/Ball material values may wrap to two lines if the finish value exceeds the maximum column width.

**Important Information and Disclaimer:**The information provided on this page represents TI's knowledge and belief as of the date that it is provided. TI bases its knowledge and belief on information provided by third parties, and makes no representation or warranty as to the accuracy of such information. Efforts are underway to better integrate information from third parties. TI has taken and continues to take reasonable steps to provide representative and accurate information but may not have conducted destructive testing or chemical analysis on incoming materials and chemicals. TI and TI suppliers consider certain information to be proprietary, and thus CAS numbers and other limited information may not be available for release.

In no event shall TI's liability arising out of such information exceed the total purchase price of the TI part(s) at issue in this document sold by TI to Customer on an annual basis.

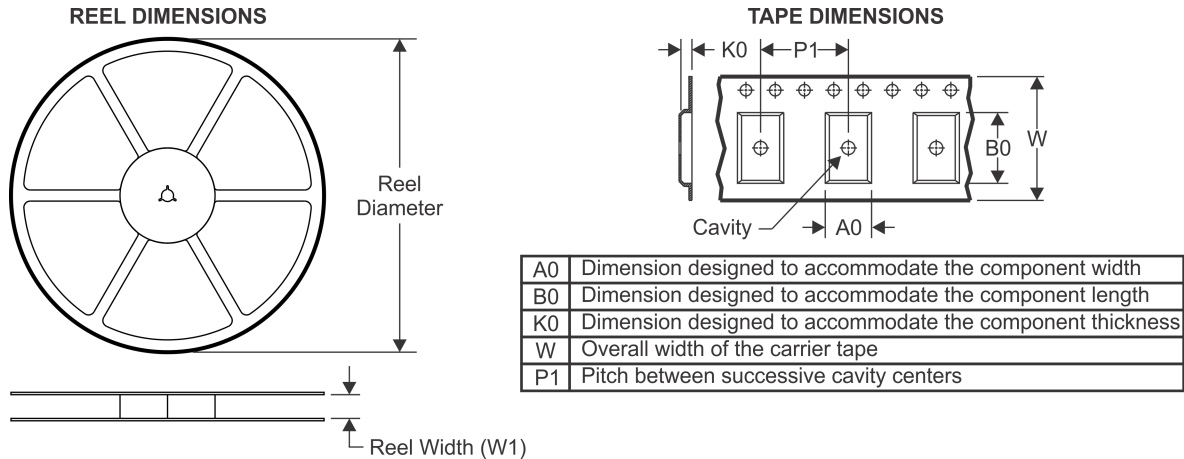
**TAPE AND REEL INFORMATION**

**QUADRANT ASSIGNMENTS FOR PIN 1 ORIENTATION IN TAPE**

\*All dimensions are nominal

Device	Package Type	Package Drawing	Pins	SPQ	Reel Diameter (mm)	Reel Width W1 (mm)	A0 (mm)	B0 (mm)	K0 (mm)	P1 (mm)	W (mm)	Pin1 Quadrant
LP87524BRNFRQ1	VQFN-HR	RNF	26	3000	330.0	12.4	4.25	4.75	1.2	8.0	12.0	Q1
LP87524BRNFTQ1	VQFN-HR	RNF	26	250	180.0	12.4	4.25	4.75	1.2	8.0	12.0	Q1
LP87524JRNFRQ1	VQFN-HR	RNF	26	3000	330.0	12.4	4.25	4.75	1.2	8.0	12.0	Q1
LP87524JRNFTQ1	VQFN-HR	RNF	26	250	180.0	12.4	4.25	4.75	1.2	8.0	12.0	Q1
LP87524PRNFRQ1	VQFN-HR	RNF	26	3000	330.0	12.4	4.25	4.75	1.2	8.0	12.0	Q1
LP87524PRNFTQ1	VQFN-HR	RNF	26	250	180.0	12.4	4.25	4.75	1.2	8.0	12.0	Q1

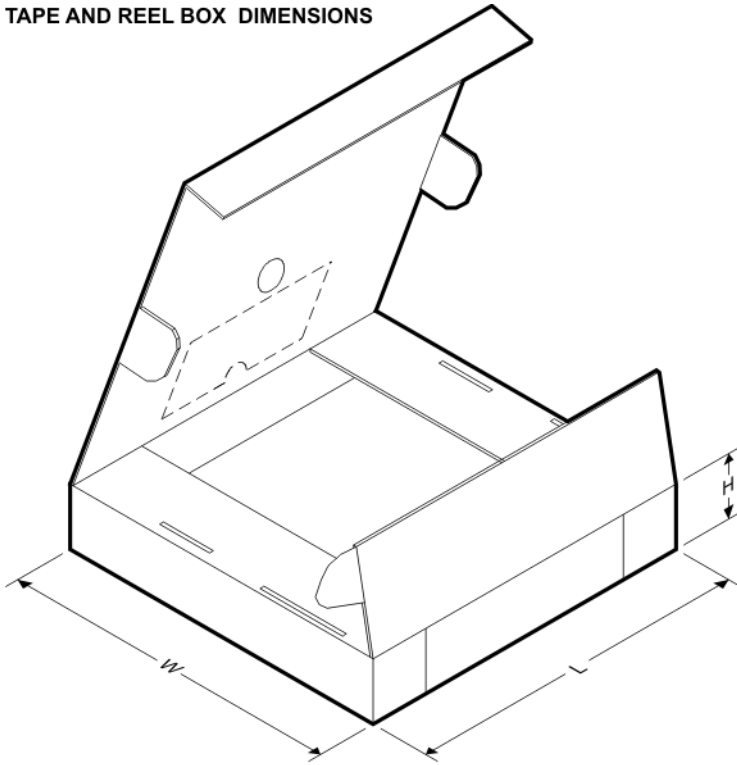
## TAPE AND REEL BOX DIMENSIONS



\*All dimensions are nominal

Device	Package Type	Package Drawing	Pins	SPQ	Length (mm)	Width (mm)	Height (mm)
LP87524BRNFRQ1	VQFN-HR	RNF	26	3000	346.0	346.0	35.0
LP87524BRNFTQ1	VQFN-HR	RNF	26	250	200.0	183.0	25.0
LP87524JRNFRQ1	VQFN-HR	RNF	26	3000	346.0	346.0	35.0
LP87524JRNFTQ1	VQFN-HR	RNF	26	250	200.0	183.0	25.0
LP87524PRNFRQ1	VQFN-HR	RNF	26	3000	346.0	346.0	35.0
LP87524PRNFTQ1	VQFN-HR	RNF	26	250	200.0	183.0	25.0

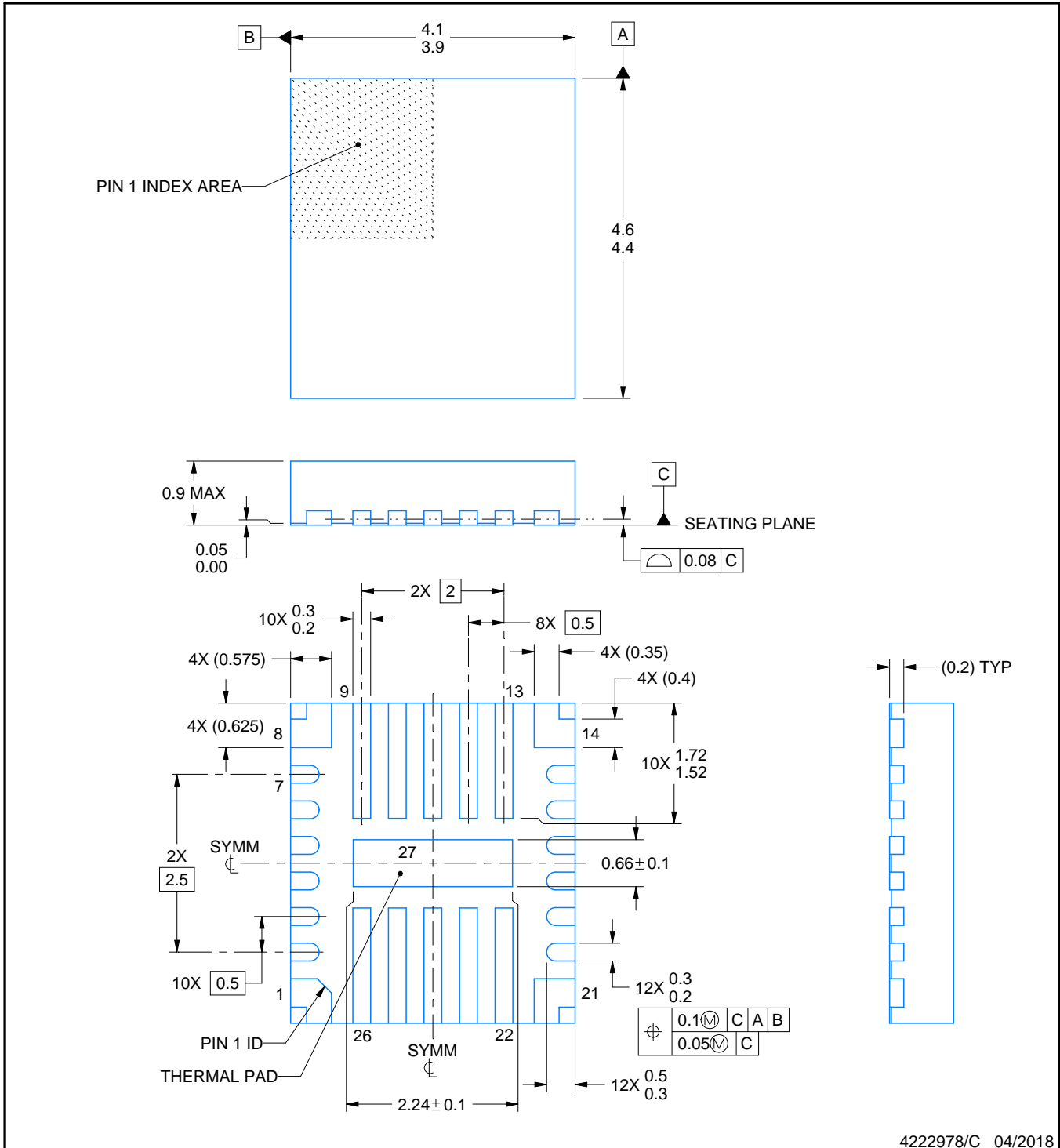
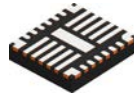

4222978/C 04/2018

NOTES:

- All linear dimensions are in millimeters. Any dimensions in parenthesis are for reference only. Dimensioning and tolerancing per ASME Y14.5M.
- This drawing is subject to change without notice.
- The package thermal pad must be soldered to the printed circuit board for thermal and mechanical performance.



# EXAMPLE STENCIL DESIGN

RNF0026B

VQFN-HR - 0.9 mm max height

PLASTIC QUAD FLATPACK - NO LEAD

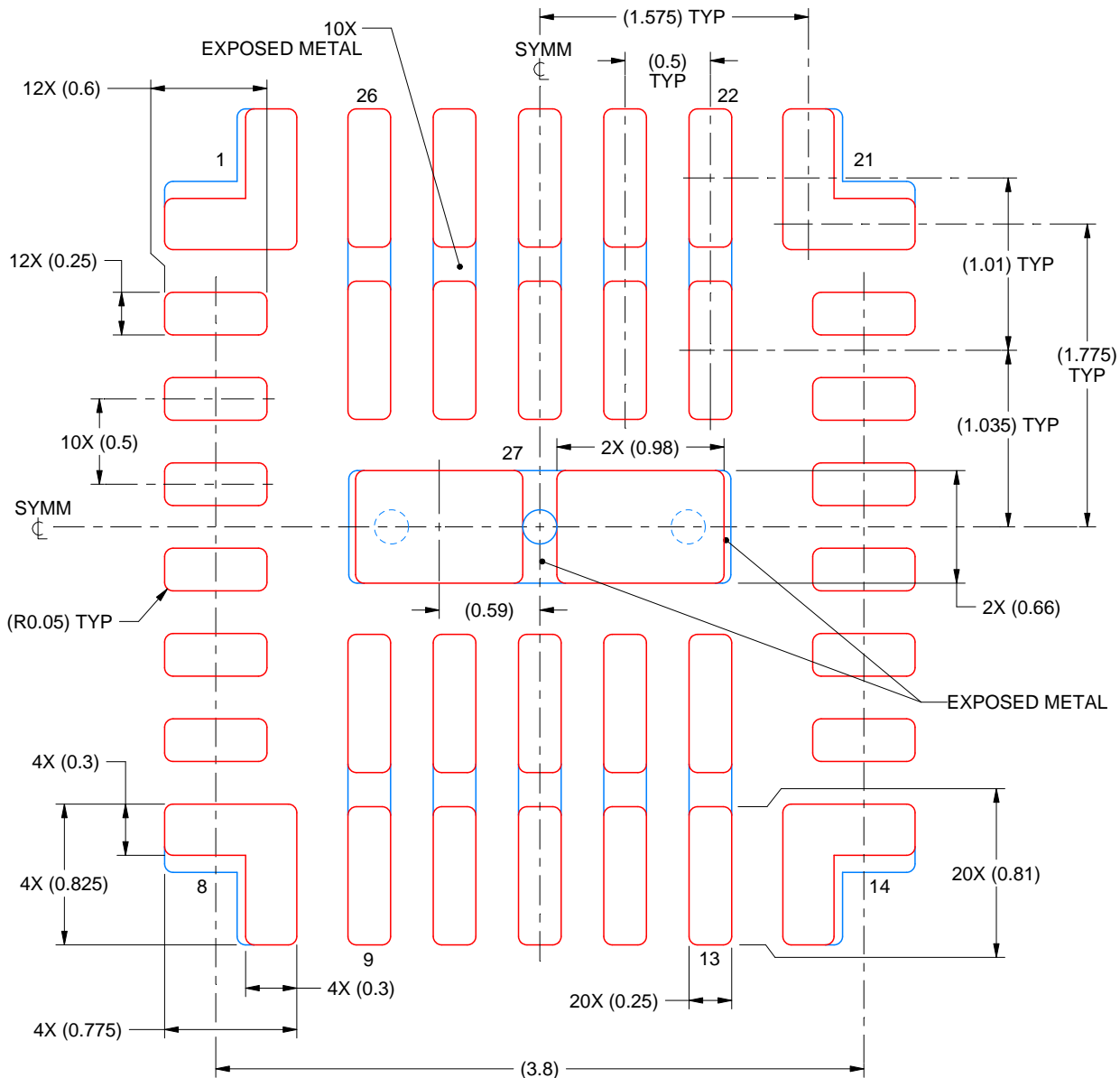

SOLDER PASTE EXAMPLE  
 BASED ON 0.125 mm THICK STENCIL

PRINTED SOLDER COVERAGE BY AREA UNDER PACKAGE  
 PADS 1, 8, 14 & 21: 87% - PADS 9-13 & 22-26: 88% - THERMAL PAD 27: 87%  
 SCALE:25X

4222978/C 04/2018

NOTES: (continued)

6. For alternate stencil design recommendations, see IPC-7525 or board assembly site preference.

## 重要声明和免责声明

TI 提供技术和可靠性数据 (包括数据表)、设计资源 (包括参考设计)、应用或其他设计建议、网络工具、安全信息和其他资源, 不保证没有瑕疵且不做任何明示或暗示的担保, 包括但不限于对适销性、某特定用途方面的适用性或不侵犯任何第三方知识产权的暗示担保。

这些资源可供使用 TI 产品进行设计的熟练开发人员使用。您将自行承担以下全部责任: (1) 针对您的应用选择合适的 TI 产品, (2) 设计、验证并测试您的应用, (3) 确保您的应用满足相应标准以及任何其他安全、安保或其他要求。这些资源如有变更, 恕不另行通知。TI 授权您仅可将这些资源用于研发本资源所述的 TI 产品的应用。严禁对这些资源进行其他复制或展示。您无权使用任何其他 TI 知识产权或任何第三方知识产权。您应全额赔偿因在这些资源的使用中对 TI 及其代表造成的任何索赔、损害、成本、损失和债务, TI 对此概不负责。

TI 提供的产品受 TI 的销售条款 (<https://www.ti.com.cn/zh-cn/legal/termsofsale.html>) 或 [ti.com.cn](https://www.ti.com.cn) 上其他适用条款/TI 产品随附的其他适用条款的约束。TI 提供这些资源并不会扩展或以其他方式更改 TI 针对 TI 产品发布的适用的担保或担保免责声明。

邮寄地址: 上海市浦东新区世纪大道 1568 号中建大厦 32 楼, 邮政编码: 200122  
Copyright © 2021 德州仪器半导体技术 (上海) 有限公司