

# 具有 50mA LDO 的 1A、单路输入、单节 LiFePO<sub>4</sub> 线性电池充电器

查询样品: [bq25070](#)

## 特性

- 单节 LiFePO<sub>4</sub> 电池充电算法
- 30V 输入额定值及 10.5V 过压保护 (OVP)
- 50mA 集成型低压降线性稳压器 (LDO)
- 可通过单个输入接口 (CTRL) 设置充电电流
- 7% 充电电流调节准确度
- 热调整及保护
- 软起动功能可减小浪涌电流
- 电池 NTC 监测

- 充电状态指示
- 采用小型 2mm × 3mm 10 引脚 SON 封装

## 应用

- 智能手机
- 移动电话
- 便携式媒体播放器
- 低功耗手持式设备

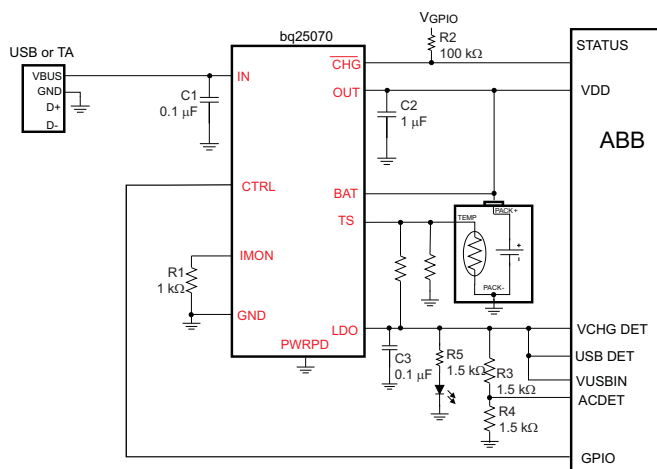
## 说明

bq25070 是一款面向空间受限便携式应用的高集成度 LiFePO<sub>4</sub> 线性电池充电器。该器件可依靠一个 USB 端口或 AC 适配器工作，并能以高达 1A 的充电电流来给单节 LiFePO<sub>4</sub> 电池充电。30V 的输入电压范围和输入过压保护功能可支持低成本的未调节适配器。

bq25070 具有单个电源输出，用于给电池充电以及为系统供电。充电电流可采用 CTRL 输入设置为高达 1A。此外，该 IC 中还集成了一个 4.9V ±10% 50mA LDO，用于为低功耗外部电路供电。充电电流可采用 CTRL 输入设置为高达 1A。此外，该 IC 中还集成了一个 4.9V ±10% 50mA LDO，用于为低功耗外部电路供电。

LiFePO<sub>4</sub> 充电算法免除了锂离子电池充电周期中常用的恒定电压模式控制。取而代之的是，将电池快速充电至过充电电压，然后使之衰减至一个较低的浮动充电电压门限。取消恒定电压控制可显著地缩短充电时间。在充电周期中，一个内部控制环路负责监视 IC 结温，并在内部温度门限被超过时减小充电电流。充电器功率级和充电电流感应功能完全集成在一起。充电器功能具有高准确度电流和电压调节环路以及充电状态显示。

## 应用电路原理图



Please be aware that an important notice concerning availability, standard warranty, and use in critical applications of Texas Instruments semiconductor products and disclaimers thereto appears at the end of this data sheet.



These devices have limited built-in ESD protection. The leads should be shorted together or the device placed in conductive foam during storage or handling to prevent electrostatic damage to the MOS gates.

### ORDERING INFORMATION<sup>(1)</sup>

PART NUMBER	I <sub>LIM(DEF)</sub>	V <sub>BAT(OVCH)</sub>	V <sub>BAT(FLOAT)</sub>	V <sub>OVP</sub>	V <sub>LDO</sub>	MARKING
bq25070DQCR	300 mA	3.7 V	3.5 V	10.5 V	4.9 V	QUS
bq25070DQCT	300 mA	3.7 V	3.5 V	10.5 V	4.9 V	QUS

- (1) For the most current package and ordering information, see the Package Option Addendum at the end of this document, or visit the device product folder on ti.com ([www.ti.com](http://www.ti.com)),

### ABSOLUTE MAXIMUM RATINGS<sup>(1)</sup>

over operating free-air temperature range (unless otherwise noted)

		VALUE	UNIT
Input Voltage	IN (with respect to GND)	-0.3 to 30	V
	CTRL, TS (with respect to GND)	-0.3 to 7	V
Output Voltage	BAT, OUT, LDO, $\overline{\text{CHG}}$ , IMON (with respect to GND)	-0.3 to 7	V
Input Current (Continuous)	IN	1.2	A
Output Current (Continuous)	BAT	1.2	A
Output Current (Continuous)	LDO	100	mA
Output Sink Current	CHG	5	mA
Junction temperature, T <sub>J</sub>		-40 to 150	°C
Storage temperature, T <sub>STG</sub>		-65 to 150	°C

- (1) Stresses beyond those listed under *absolute maximum ratings* may cause permanent damage to the device. These are stress ratings only, and functional operation of the device at these or any other conditions beyond those indicated under *recommended operating conditions* is not implied. Exposure to absolute-maximum-rated conditions for extended periods may affect device reliability. All voltage values are with respect to the network ground terminal unless otherwise noted.

### THERMAL INFORMATION

THERMAL METRIC <sup>(1)</sup>		bq25070	
		SON	UNITS
		10 PINS	
$\theta_{JA}$	Junction-to-ambient thermal resistance <sup>(2)</sup>	58.7	°C/W
$\theta_{JCTop}$	Junction-to-case (top) thermal resistance <sup>(3)</sup>	3.9	

- (1) 有关传统和新的热量的更多信息，请参阅 IC 封装热量量 应用报告 [SPRA953](#)。  
 (2) 在 JESD51-2a 描述的环境中，按照 JESD51-7 的指定在一个 JEDEC 标准 high-K 测试电路板上进行仿真，从而获得自然对流条件下的结到外部热阻。  
 (3) 通过在封装顶部进行冷板测试仿真来获得结到芯片外壳（顶部）热阻。不存在特定的 JEDEC 标准测试，但可在 ANSI SEMI 标准 G30-88 中找到内容接近的说明。

### RECOMMENDED OPERATING CONDITIONS

		MIN	MAX	UNITS
V <sub>IN</sub>	IN voltage range	3.75 <sup>(1)</sup>	28	V
	IN operating voltage range	3.75 <sup>(1)</sup>	10.2	
I <sub>IN</sub>	Input current, IN		1	A
I <sub>OUT</sub>	Output Current in charge mode, OUT		1	A
T <sub>J</sub>	Junction Temperature	0	125	°C

- (1) Charge current may be limited at low input voltages due to the dropout of the device.

## ELECTRICAL CHARACTERISTICS

Over junction temperature range  $0^{\circ}\text{C} \leq T_J \leq 125^{\circ}\text{C}$  and recommended supply voltage (unless otherwise noted)

PARAMETER		TEST CONDITIONS	MIN	TYP	MAX	UNITS	
<b>INPUT</b>							
$V_{UVLO}$	Under-voltage lock-out	$V_{IN}: 0\text{ V} \rightarrow 4\text{ V}$	3.15	3.30	3.55	V	
$V_{HYS-UVLO}$	Hysteresis on UVLO	$V_{IN}: 4\text{ V} \rightarrow 0\text{ V}$		250		mV	
$V_{BATUVLO}$	Battery UVLO	$V_{BAT}$ rising	1.95	2.05	2.15	V	
$V_{HYS-BUVLO}$	Hysteresis on BAT UVLO	$V_{BAT}$ falling		125		mV	
$V_{IN-SLP}$	Valid input source threshold $V_{IN-SLP}$ above $V_{BAT}$	Input power good if $V_{IN} > V_{BAT} + V_{IN-SLP}$ $V_{BAT} = 3.6\text{ V}$ , $V_{IN}: 3.5\text{ V} \rightarrow 4\text{ V}$	30	75	150	mV	
$V_{HYS-INSLP}$	Hysteresis on $V_{IN-SLP}$	$V_{BAT} = 3.6\text{ V}$ , $V_{IN}: 4\text{ V} \rightarrow 3.5\text{ V}$	18	32	54	mV	
$t_{DGL(NO-IN)}$	Delay time, input power loss to charger turn-off	Time measured from $V_{IN}: 5\text{ V} \rightarrow 2.5\text{ V}$ 1 $\mu\text{s}$ fall-time		32		ms	
$V_{OVP}$	Input over-voltage protection threshold	$V_{IN}: 5\text{ V} \rightarrow 11\text{ V}$	10.2	10.5	10.8	V	
$V_{HYS-OVP}$	Hysteresis on OVP	$V_{IN}: 11\text{ V} \rightarrow 5\text{ V}$		100		mV	
$t_{BLK(OVP)}$	Input over-voltage blanking time			100		$\mu\text{s}$	
$t_{REC(OVP)}$	Input over-voltage recovery time	Time measured from $V_{IN}: 11\text{ V} \rightarrow 5\text{ V}$ 1 $\mu\text{s}$ fall-time to LDO = HI, $V_{BAT} = 3.5\text{ V}$		100		$\mu\text{s}$	
<b>QUIESCENT CURRENT</b>							
$I_{BAT(PDWN)}$	Battery current into BAT, No input connected	$V_{IN} = 0\text{ V}$ , $\overline{V_{CHG}} = \text{High}$ , TS Enabled		120	150	$\mu\text{A}$	
		$V_{IN} = 0\text{ V}$ , $\overline{V_{CHG}} = \text{Low}$ , TS Disabled, $T_J = 85^{\circ}\text{C}$			6	$\mu\text{A}$	
$I_{IN(STDBY)}$	Standby current into IN pin	CTRL = HI, $V_{IN} = 5.5\text{ V}$			0.25	mA	
		CTRL = HI, $V_{IN} \leq V_{OVP}$			0.5		
		CTRL = HI, $V_{IN} > V_{OVP}$			2		
ICC	Active supply current, IN pin	$V_{IN} = 6\text{ V}$ , No load on OUT pin, $V_{BAT} > V_{BAT(REG)}$ , IC enabled			3	mA	
<b>BATTERY CHARGER FAST-CHARGE</b>							
$V_{BAT(REG)}$	Battery float charge voltage	$T_A = 0^{\circ}\text{C}$ to $125^{\circ}\text{C}$	3.465	3.5	3.535	V	
		$T_A = 25^{\circ}\text{C}$	3.465	3.5	3.529		
$V_{BAT(OVCH)}$	Battery overcharge voltage threshold		3.62	3.7	3.78	V	
$I_{IN(LIM)}$	Input Current Limit (selected by CTRL interface)	4 pulses on CTRL		87	93	100	mA
		5 pulses on CTRL		174	187	200	
		6 pulses on CTRL		261	280	300	
		7 pulses on CTRL		348	374	400	
		8 pulses on CTRL		435	467	500	
		9 pulses on CTRL		608	654	700	
		10 pulses on CTRL		739	794	850	
		11 pulses on CTRL		869	935	1000	
$V_{DO(IN-OUT)}$	$V_{IN} - V_{OUT}$	$V_{IN} = 3.5\text{ V}$ , $I_{OUT} = 0.75\text{ A}$		500	1400	mV	
$K_{IMON}$	Input current monitor ratio	$K_{IMON} = I_{IMON} / I_{CHG}$ , $R_{IMON} = 1\text{k}\Omega$ , Current programmed using CTRL		1		mA / A	
$V_{IMON(MAX)}$	Maximum IMON voltage	IMON open		1.2	1.25	V	
	IMON Accuracy	$I_{IN} < 100\text{ mA}$	-25%		25%		
		$I_{IN} = 100\text{ mA}$ to $1\text{ A}$	-10%		10%		
<b>PRE-CHARGE AND CHARGE DONE</b>							
$V_{LOWV}$	Pre-charge to fast-charge transition threshold		2.4	2.5	2.6	V	
$t_{DGL1(LOWV)}$	Deglintch time on pre-charge to fast-charge transition			25		ms	
$t_{DGL2(LOWV)}$	Deglintch time on fast-charge to pre-charge transition			25		ms	

## ELECTRICAL CHARACTERISTICS (continued)

Over junction temperature range  $0^{\circ}\text{C} \leq T_J \leq 125^{\circ}\text{C}$  and recommended supply voltage (unless otherwise noted)

PARAMETER		TEST CONDITIONS	MIN	TYP	MAX	UNITS
$I_{\text{PRECHARGE}}$	Precharge current to BAT during precharge mode	$V_{\text{BAT}} = 0 \text{ V to } 0.7 \text{ V}$	41.5	45	48.5	mA
<b>RECHARGE OR REFRESH</b>						
$V_{\text{RCH}}$	Recharge detection threshold	$V_{\text{BAT}}$ falling	3.1	3.3	3.5	V
$t_{\text{DGL(RCH)}}$	Deglintch time, recharge threshold detected	$V_{\text{BAT}}$ falling to New Charge Cycle		25		ms
<b>LDO</b>						
$V_{\text{LDO}}$	LDO Output Voltage	$V_{\text{IN}} = 5 \text{ V to } 10.5 \text{ V}$ , $I_{\text{LDO}} = 0 \text{ mA to } 50 \text{ mA}$	4.7	4.9	5.1	V
$I_{\text{LDO}}$	Maximum LDO Output Current		60			mA
$V_{\text{DO}}$	Dropout Voltage	$V_{\text{IN}} = 4.5\text{V}$ , $I_{\text{LDO}} = 50\text{mA}$		200	350	mV
<b>CTRL INTERFACE</b>						
$t_{\text{CTRL\_DGL}}$	CTRL Deglitch timer		5			ms
$t_{\text{CTRL\_LATCH}}$	CTRL Latch timer		2			ms
$t_{\text{HI\_MIN}}$	High Duration on CTRL		50		1000	$\mu\text{s}$
$t_{\text{LO\_MIN}}$	Low Time Duration on CTRL		50		1000	$\mu\text{s}$
$R_{\text{PULLDOWN}}$	CTRL Pulldown Resistor			260		k $\Omega$
<b>LOGIC LEVELS ON CTRL</b>						
$V_{\text{IL}}$	Logic LOW input voltage				0.4	V
$V_{\text{IH}}$	Logic HIGH input voltage		1.4			V
<b>BATTERY-PACK NTC MONITOR (TS)</b>						
$V_{\text{COLD}}$	TS Cold Threshold	$V_{\text{TS}}$ Rising	24.5	25	25.5	$\%V_{\text{LDO}}$
$V_{\text{CUTOFF}}$	TS Cold Cutoff Threshold	$V_{\text{TS}}$ Falling		1		$\%V_{\text{LDO}}$
$V_{\text{HOT}}$	TS Hot Threshold	$V_{\text{TS}}$ Falling	12	12.5	13	$\%V_{\text{LDO}}$
$V_{\text{HOT\_HYS}}$	TS Hot Cutoff Threshold	$V_{\text{TS}}$ Rising		1		$\%V_{\text{LDO}}$
$t_{\text{dgl(TS)}}$	Deglitch for TS Fault	Fault detected on TS to stop charge		25		ms
<b>CHG OUTPUT</b>						
$V_{\text{OL}}$	Output LOW voltage	$I_{\text{SINK}} = 1 \text{ mA}$			0.45	V
$I_{\text{IH}}$	Leakage current	$\overline{\text{CHG}} = 5 \text{ V}$			1	$\mu\text{A}$
$t_{\text{FLSH(TS)}}$	TS fault flash period	50% Duty Cycle, TS out of valid range		100		ms
<b>THERMAL REGULATION</b>						
$T_{\text{J(REG)}}$	Temperature Regulation Limit	$T_J$ rising		125		C
$T_{\text{J(OFF)}}$	Thermal shutdown temperature	$T_J$ rising		155		C
$T_{\text{J(OFF-HYS)}}$	Thermal shutdown hysteresis	$T_J$ falling		20		C

**TYPICAL CHARACTERISTICS**

$V_{IN} = 5\text{ V}$ ,  $V_{BAT} = 3.2\text{ V}$ ,  $I_{CHG} = 280\text{ mA}$ , Typical Application Circuit

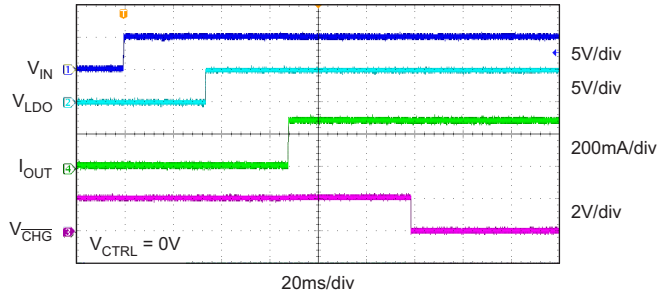


Figure 1. Adapter Plug-In With Battery Connected

G001

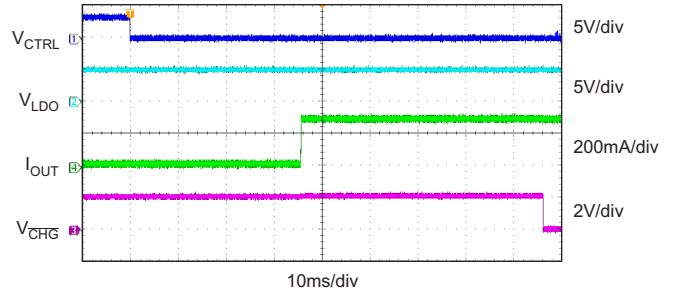


Figure 2. Charger Enable Using CTRL

G002

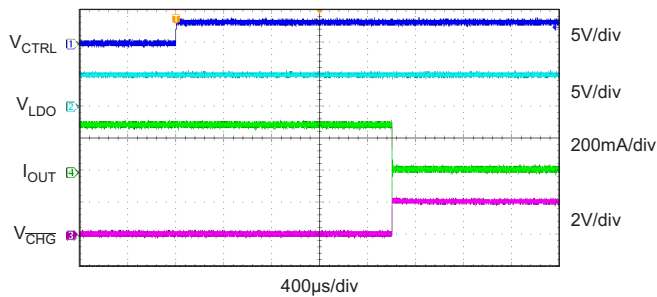


Figure 3. Charger Disable Using CTRL

G003

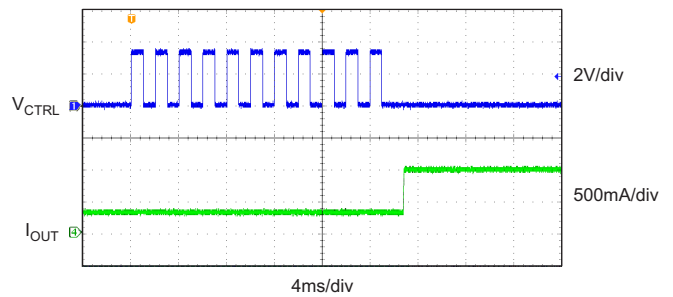


Figure 4. Default to 1A Transition Using CTRL

G004

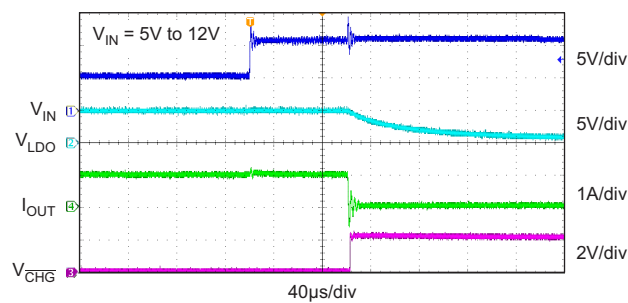


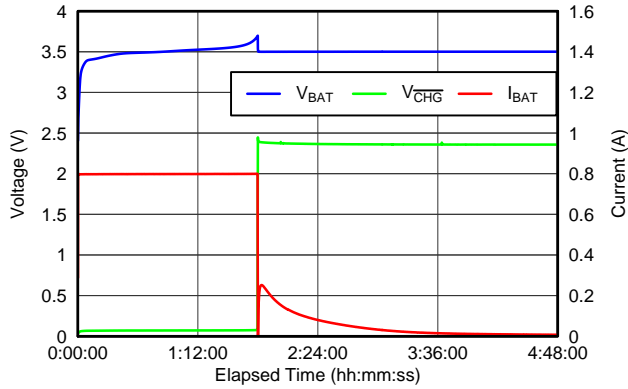
Figure 5. OVP Fault

G005

**TYPICAL CHARACTERISTICS (continued)**

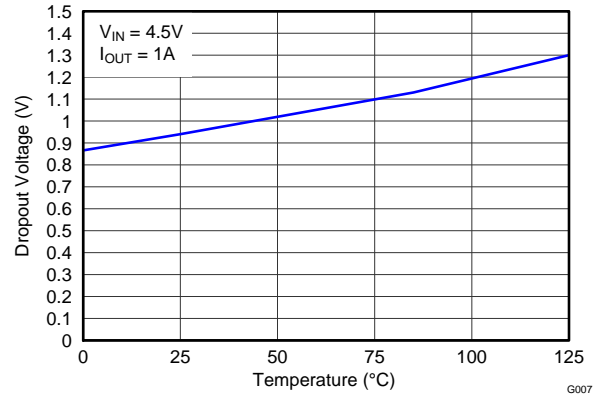
$V_{IN} = 5\text{ V}$ ,  $V_{BAT} = 3.2\text{ V}$ ,  $I_{CHG} = 280\text{ mA}$ , Typical Application Circuit

**VOLTAGE and CURRENT  
vs  
ELAPSED TIME**



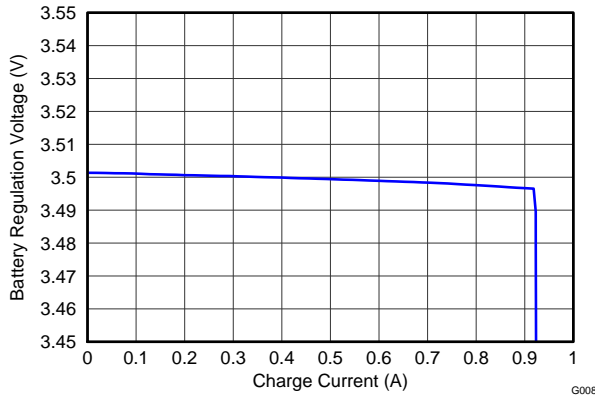
**Figure 6. Complete Charge Cycle**

**DROPOUT VOLTAGE  
vs  
TEMPERATURE**



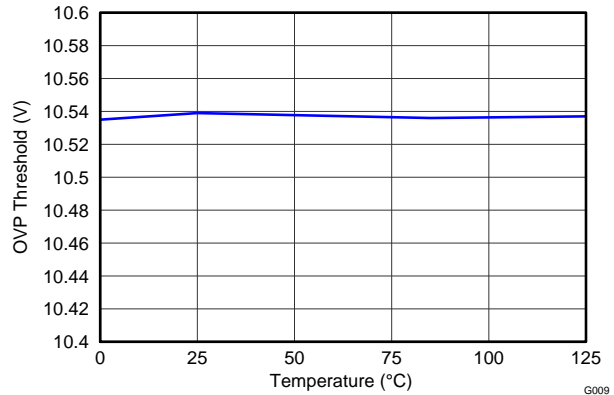
**Figure 7.**

**BATTERY REGULATION VOLTAGE  
vs  
CHARGE CURRENT**



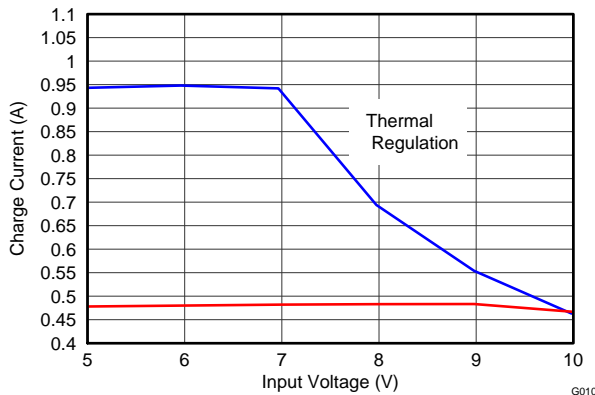
**Figure 8.**

**OVP THRESHOLD  
vs  
TEMPERATURE**



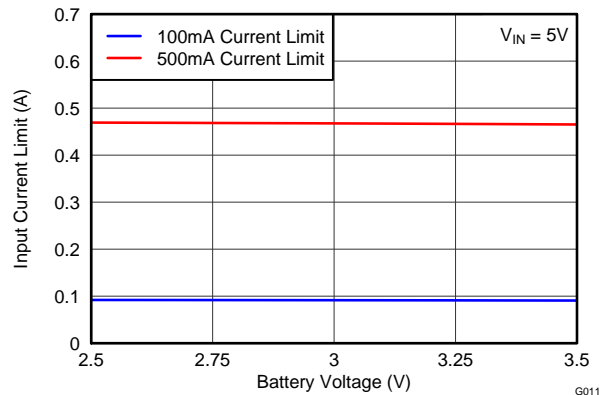
**Figure 9.**

**CHARGE CURRENT  
vs  
INPUT VOLTAGE**



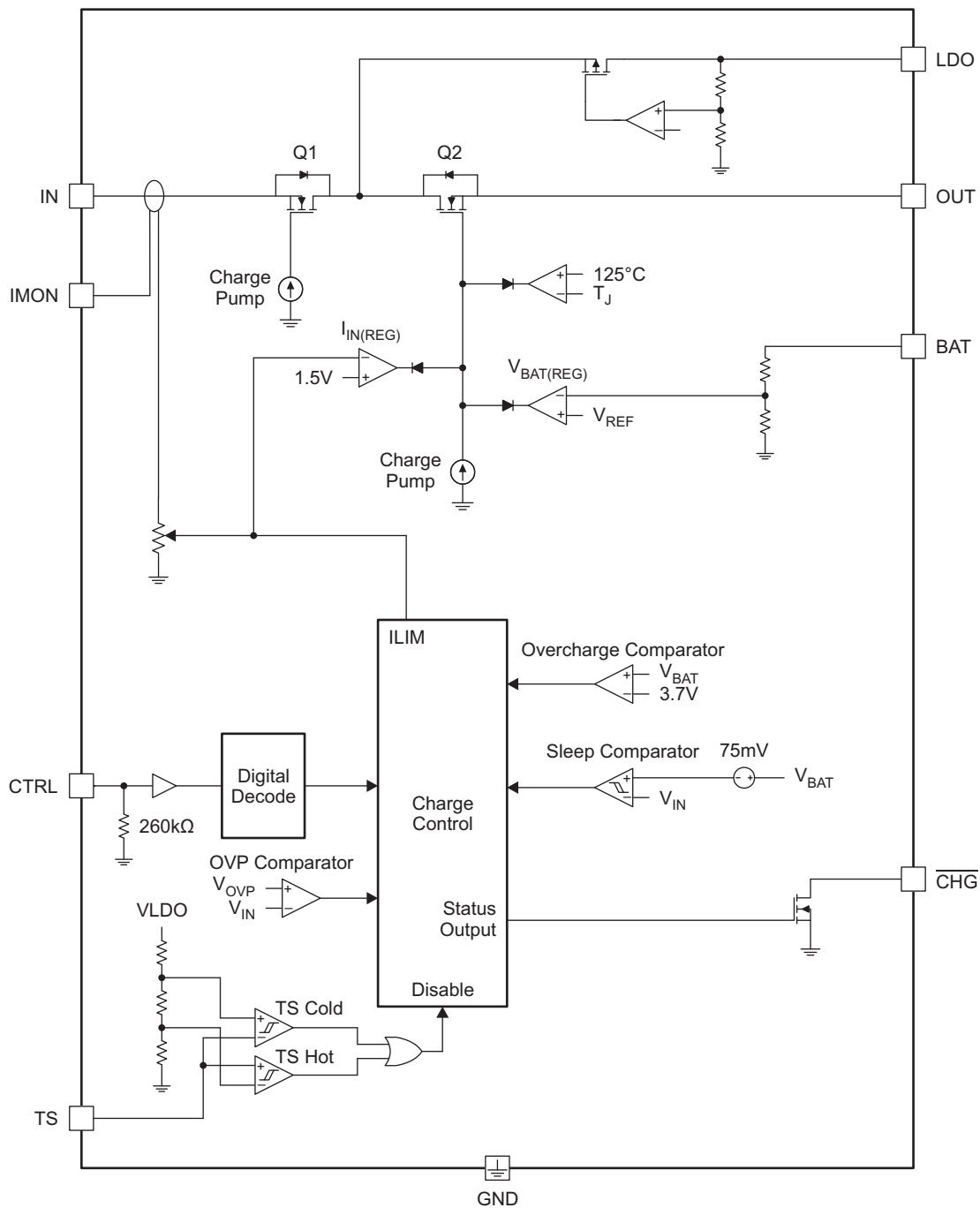
**Figure 10.**

**INPUT CURRENT LIMIT  
vs  
BATTERY VOLTAGE**

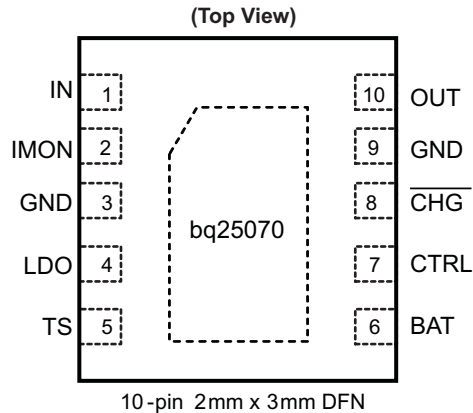


**Figure 11.**

SIMPLIFIED BLOCK DIAGRAM



## PIN CONFIGURATION



## PIN FUNCTIONS

PIN		I/O	DESCRIPTION
NAME	NO.		
IN	1	I	Input power supply. IN is connected to the external DC supply (AC adapter or USB port). Bypass IN to GND with at least a 0.1µF ceramic capacitor.
IMON	2	O	Current monitoring output. Connect a 1kΩ resistor from IMON to GND to monitor the input current. The voltage at IMON ranges from 0V to 1V which corresponds to an input current from 0A to 1A.
GND	3, 9	–	Ground terminal. Connect to the thermal pad and the ground plane of the circuit.
LDO	4	O	LDO output. LDO is regulated to 4.9V and drives up to 50mA. Bypass LDO to GND with a 0.1µF ceramic capacitor. LDO is enabled when $V_{UVLO} < V_{IN} < V_{OVP}$ .
TS	5	I	Battery pack NTC monitoring input. Connect a resistor divider from LDO to GND with TS connected to the center tap to set the charge temperature window. The battery pack NTC is connected in parallel with the bottom resistor of the divider. See the Applications Design section for details on the selecting the proper component values.
BAT	6	O	Battery connection output. BAT is the sense input for the battery. Connect BAT and OUT to the battery and bypass to GND with a 1µF ceramic capacitor.
CTRL	7	I	Single-input interface Input. Drive CTRL with pulses to enable/disable the device, enable/disable $V_{IN-DPM}$ , and select current limits. See the interface section for details on using the CTRL interface.
CHG	8	O	Charge status indicator open-drain output. CHG is pulled low while the device is charging the battery. CHG goes high impedance when the battery is fully charged.
OUT	10	O	System output connection. Connect OUT and BAT together. Bypass the OUT and BAT connection to GND with a 1µF ceramic capacitor.
Thermal PAD	Pad	–	There is an internal electrical connection between the exposed thermal pad and the GND pin of the device. The thermal pad must be connected to the same potential as the GND pin on the printed circuit board. Do not use the thermal pad as the primary ground input for the device. GND pin must be connected to ground at all times.

APPLICATIONS CIRCUITS

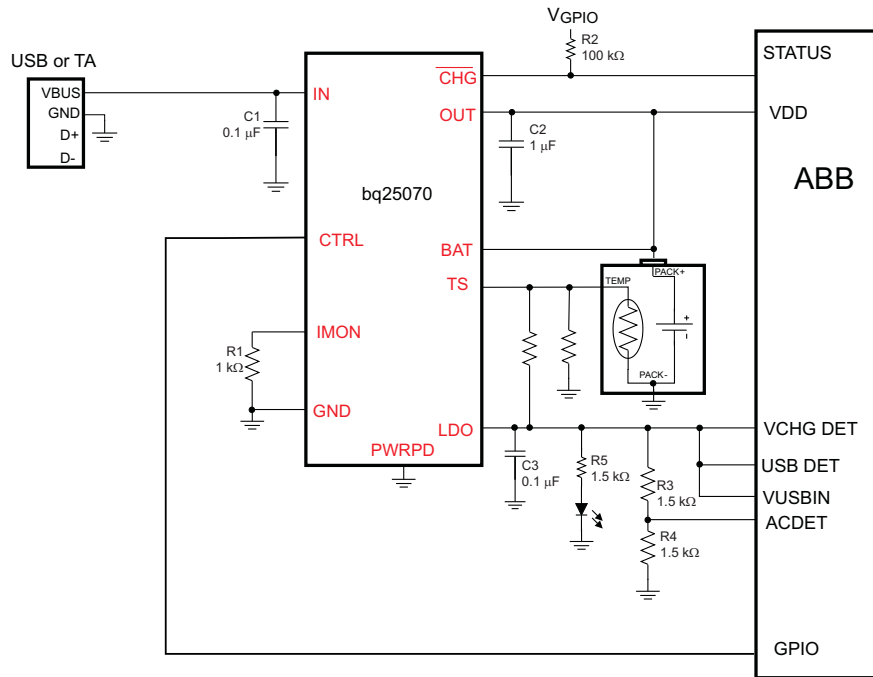


Figure 12. bq25070 Typical Application Circuit

## DETAILED FUNCTIONAL DESCRIPTION

The bq25070 is a highly integrated LiFePO<sub>4</sub> linear battery charger targeted at space-limited portable applications. It operates from either a USB port or AC Adapter and charges a single-cell LiFePO<sub>4</sub> battery with up to 1A of charge current. The 30V input voltage range with input over-voltage protections supports low-cost unregulated adapters.

The LiFePO<sub>4</sub> charging algorithm removes the constant voltage mode control usually present in Li-Ion battery charge cycles. Instead, the battery is charged with the fastcharge current to the overcharge voltage and then allowed to relax to a lower float charge voltage threshold. The removal of the constant voltage control reduces charge time significantly. During the charge cycle, an internal control loop monitors the IC junction temperature and reduces the charge current if an internal temperature threshold is exceeded. The charger power stage and charge current sense functions are fully integrated. The charger function has high accuracy voltage and current regulation loops, and charge status display.

### CHARGING OPERATION

The bq25070 uses a charge algorithm that is unique to LiFePO<sub>4</sub> chemistry cells. The constant voltage mode control usually present in Li-Ion battery charge cycles is eliminated. This dramatically decreases the charge time. When the bq25070 is enabled by CTRL, the battery voltage is monitored to verify which stage of charging must be used. When  $V_{BAT} < V_{LOWV}$ , the bq25070 charges in precharge mode; when  $V_{BAT} > V_{LOWV}$ , the normal charge cycle is used.

#### Charger Operation with Minimum System Voltage Mode Enabled

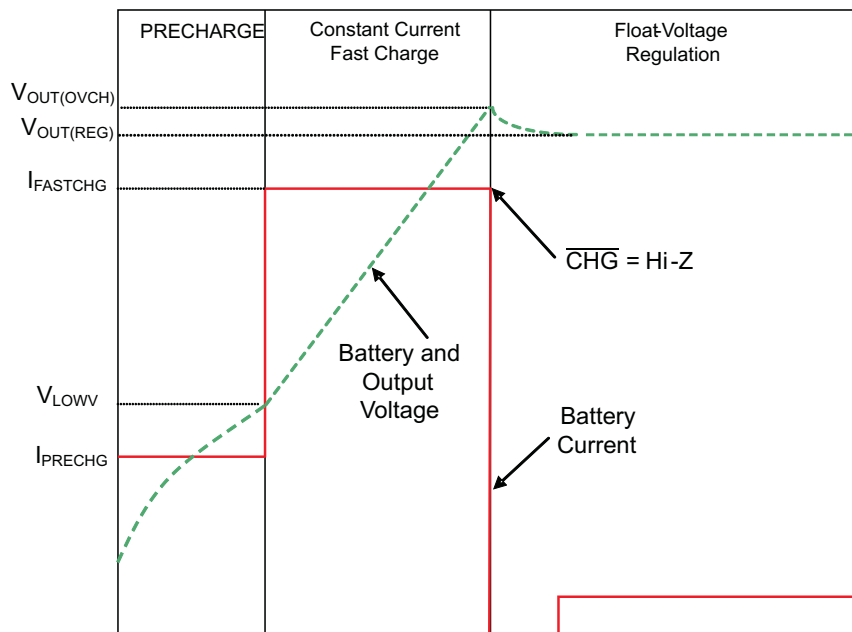


Figure 13. Typical Charging Cycle with Minimum System Voltage Enabled

#### Precharge Mode ( $V_{BAT} \leq V_{LOWV}$ )

The bq25070 enters precharge mode when  $V_{BAT} \leq V_{LOWV}$ . Upon entering precharge mode, the battery is charged with a 47.5mA current and  $\overline{CHG}$  goes low.

## Fast Charge Mode

Once  $V_{BAT} > V_{LOWV}$ , the bq25070 enters constant current (CC) mode where charge current is regulated using the internal MOSFETs between IN and OUT. The total current is shared between the output load and the battery. Once the battery voltage charges up to  $V_{BAT(OVCH)}$ , the **CHG** output goes high indicating the charge cycle is complete and the bq25070 switches the battery regulation voltage to  $V_{BAT(REG)}$ . The battery voltage is allowed to relax down to  $V_{BAT(REG)}$ . The charger remains enabled and regulates the output to  $V_{BAT(REG)}$ . If at any time the battery falls below  $V_{REC}$ , the charge cycle restarts.

## CHARGE CURRENT TRANSLATOR (IMON)

When the charger is enabled, internal circuits generate a current proportional to the charge current at the IMON input. The current out of IMON is 1/1000 ( $\pm 10\%$ ) of the charge current. This current, when applied to the external charge current programming resistor, R1 (Figure 12), generates an analog voltage that can be monitored by an external host to calculate the current sourced from BAT. Connect a 1k $\Omega$  resistor from IMON to GND. The voltage at IMON is calculated as:

$$V_{IMON} = I_{IN} \times 1 \frac{V}{A} \quad (1)$$

## INPUT OVER VOLTAGE PROTECTION

The bq25070 contains an input over voltage protection circuit that disables the LDO output and charging when the input voltage rises above  $V_{OVP}$ . This prevents damage from faulty adapters. The OVP circuitry contains an 115 $\mu$ s deglitch that prevents ringing on the input from line transients from tripping the OVP circuitry falsely. If an adapter with an output greater than  $V_{OVP}$  is plugged in, the IC completes soft-start power up and then shuts down if the voltage remains above  $V_{OVP}$  after 115 $\mu$ s. The LDO remains off and charging remains disabled until the input voltage falls below  $V_{OVP}$ .

## UNDER-VOLTAGE LOCKOUT (UVLO)

The bq25070 remains in power down mode when the input voltage is below the under-voltage lockout threshold ( $V_{UVLO}$ ). During this mode, the control input (CTRL) is ignored. The LDO, the charge FET connected between IN and OUT are off and the status output (CHG) is high impedance. Once the input voltage rises above  $V_{UVLO}$ , the internal circuitry is turned on and the normal operating procedures are followed.

## EXTERNAL NTC MONITORING (TS)

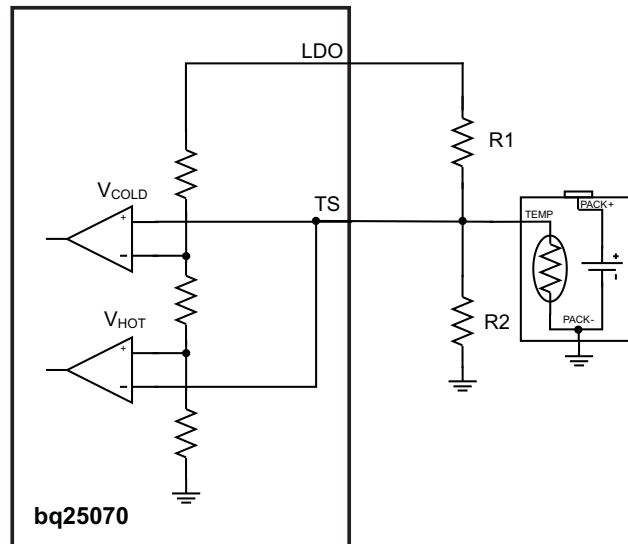
The bq25070 features a flexible, voltage based external battery pack temperature monitoring input. The TS input connects to the NTC thermistor in the battery pack to monitor battery temperature and prevent dangerous over-temperature conditions. During charging, the voltage at TS is continuously monitored. If, at any time, the voltage at TS is outside of the operating range ( $V_{COLD}$  to  $V_{HOT}$ ), charging is suspended. When the voltage measured at TS returns to within the operation window, charging is resumed. When charging is suspended due to a battery pack temperature fault, the CHG output remains low and continues to indicate charging.

The temperature thresholds are programmed using a resistor divider from LDO to GND with the NTC thermistor connected to the center tap from TS to GND. See Figure 14 for the circuit example. The value of R1 and R2 are calculated using the following equations:

$$R1 = \frac{-R2 \times RHOT \times (0.125 - 1)}{0.125 \times (R2 + RHOT)} \quad (2)$$

$$R2 = \frac{-RHOT \times RCOLD \times (0.125 - 0.250)}{RHOT \times 0.250 \times (0.125 - 1) + RCOLD \times 0.125 \times (1 - 0.250)} \quad (3)$$

RHOT is the expected thermistor resistance at the programmed hot threshold; RCOLD is the expected thermistor resistance at the programmed cold threshold.



For applications that do not require the TS monitoring function, set  $R1 = 490k\Omega$  and  $R2 = 100k\Omega$  to set the TS voltage at a valid level and maintain charging.

**Figure 14. NTC Monitoring Function**

### 50 mA LDO (LDO)

The LDO output of the bq25070 is a low dropout linear regulator (LDO) that supplies up to 50mA while regulating to  $V_{LDO}$ . The LDO is active whenever the input voltage is above  $V_{UVLO}$  and below  $V_{OVP}$ . It is not affected by the CTRL input. The LDO output is used to power and protect circuitry such as USB transceivers from transients on the input supply.

### CHARGE STATUS INDICATOR ( $\overline{CHG}$ )

The bq25070 contains an open drain  $\overline{CHG}$  output that indicates when charge cycles and faults. When charging a battery in precharge or fastcharge mode, the  $\overline{CHG}$  output is pulled to GND. Once the BAT output reaches the overcharge voltage threshold,  $\overline{CHG}$  goes high impedance to signal the battery is fully charged. The  $\overline{CHG}$  output goes low during battery recharge cycles to signal the host.

Additionally,  $\overline{CHG}$  notifies the host if a NTC temperature fault has occurred.  $\overline{CHG}$  pulses with a period of 100ms and a 50% duty cycle if a TS faults occurs. Connect  $\overline{CHG}$  to the required logic level voltage through a  $1k\Omega$  to  $100k\Omega$  resistor to use the signal with a microprocessor.  $I_{CHG}$  must be below 5mA.

The IC monitors the CHG pin when no input is connected to verify if the system circuitry is active. If the voltage at CHG is logic being drive low when no input is connected, the TS circuit is turned off for a low quiescent current state. Once the voltage at CHG increases above logic high, the TS circuit is turned on.

### SINGLE INPUT INTERFACE (CTRL)

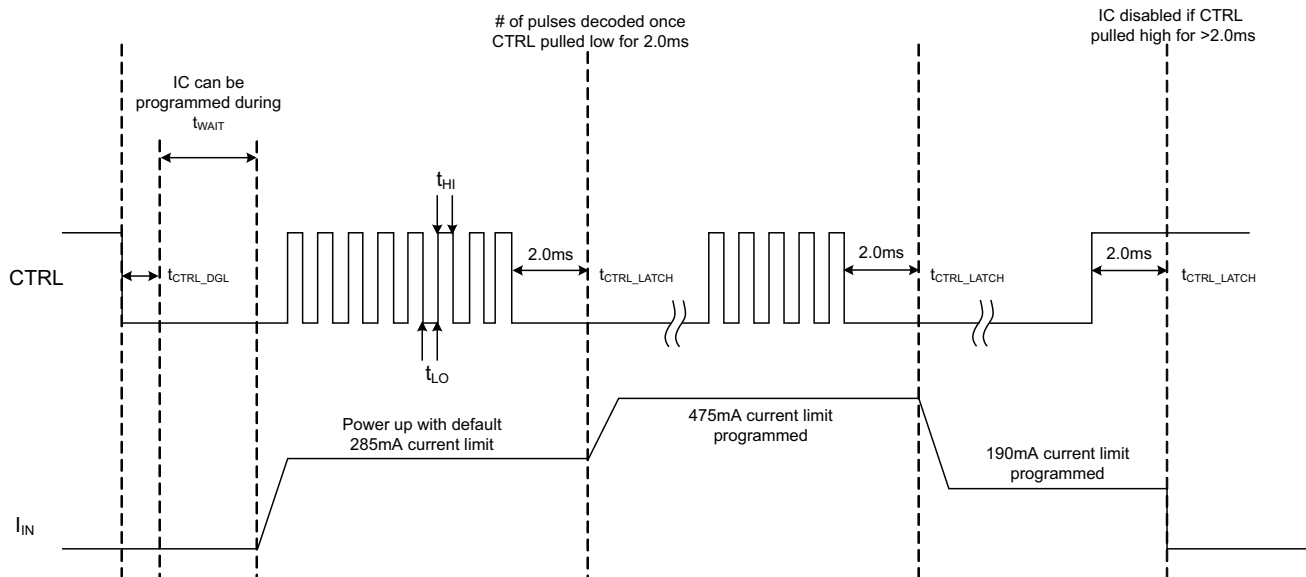
CTRL is used to enable/disable the device as well as select the input current limit, enable/disable charge, extend the TS operation range and disable  $V_{IN}$ -DPM mode. CTRL is pulled low to enable the device. After the  $50\mu s$  deglitch expires, the IC enters the 32ms WAIT state. CTRL may be used to program the bq25070 during this time. Once  $t_{WAIT}$  expires, the IC starts up. If no command is sent to CTRL during  $t_{WAIT}$ , the IC starts up with a default 285mA current limit.

Programming the different modes is done by pulsing the CTRL input. See [Table 1](#) for a map of the different modes. The width of the CTRL pulses is unimportant as long as they are between  $50\mu s$  and  $1000\mu s$  long. The time between pulses must be between  $50\mu s$  and  $1000\mu s$  to be properly read. Once CTRL is held low for 2ms, the number of pulses is passed to the control logic and decoded and then the mode changes. To ensure proper operation, do not send more than 16 pulses in one programming cycle.

**Table 1. Pulse Counting Map for CTRL Interface**

# of Pulses	Current Limit
1	No Change
2	No Change
3	No Change
4	93 mA
5	187 mA
6	280 mA
7	374 mA
8	467 mA
9	654 mA
10	794 mA
11	935 mA
>11	No Change

If, at any time, the CTRL input is held high for more than 2ms, the IC is disabled. When disabled, charging is suspended and the bq25070 input quiescent current is reduced.



**Figure 15. CTRL Timing Diagram**

## THERMAL REGULATION AND THERMAL SHUTDOWN

The bq25070 contains a thermal regulation loop that monitors the die temperature continuously. If the temperature exceeds  $T_{J(REG)}$ , the device automatically reduces the charging current to prevent the die temperature from increasing further. In some cases, the die temperature continues to rise despite the operation of the thermal loop, particularly under high  $V_{IN}$  conditions. If the die temperature increases to  $T_{J(OFF)}$ , the IC is turned off. Once the device die temperature cools by  $T_{J(OFF-HYS)}$ , the device turns on and returns to thermal regulation. Continuous over-temperature conditions result in the pulsing of the load current. If the junction temperature of the device exceeds  $T_{J(OFF)}$ , the charge FET is turned off. The FET is turned back on when the junction temperature falls below  $T_{J(OFF)} - T_{J(OFF-HYS)}$ .

Note that these features monitor the die temperature of the bq25070. This is not synonymous with ambient temperature. Self heating exists due to the power dissipated in the IC because of the linear nature of the battery charging algorithm.

## APPLICATION INFORMATION

### SELECTION OF INPUT/OUTPUT CAPACITORS

In most applications, all that is needed is a high-frequency decoupling capacitor on the input power pin. For normal charging applications, a 0.1µF ceramic capacitor, placed in close proximity to the IN pin and GND pad works best. In some applications, depending on the power supply characteristics and cable length, it may be necessary to increase the input filter capacitor to avoid exceeding the OVP voltage threshold during adapter hot plug events where the ringing exceeds the deglitch time.

The charger in the bq25070 requires a capacitor from OUT to GND for loop stability. Connect a 1µF ceramic capacitor from BAT to GND close to the pins for best results. More output capacitance may be required to minimize the output droop during large load transients.

The LDO also requires an output capacitor for loop stability. Connect a 0.1µF ceramic capacitor from LDO to GND close to the pins. For improved transient response, this capacitor may be increased.

### THERMAL CONSIDERATIONS

The bq25070 is packaged in a thermally enhanced QFN package. The package includes a thermal pad to provide an effective thermal contact between the IC and the printed circuit board (PCB). Full PCB design guidelines for this package are provided in the application note entitled: *QFN/SON PCB Attachment Application Note (SLUA271)*.

The most common measure of package thermal performance is thermal impedance ( $\theta_{JA}$ ) measured (or modeled) from the chip junction to the air surrounding the package surface (ambient). The mathematical expression for  $\theta_{JA}$  is:

Where:

$$\theta_{JA} = \frac{T_J - T_A}{P_D} \quad (4)$$

$T_J$  = chip junction temperature

$T_A$  = ambient temperature

$P_D$  = device power dissipation

Factors that can greatly influence the measurement and calculation of  $\theta_{JA}$  include:

- Whether or not the device is board mounted
- Trace size, composition, thickness, and geometry
- Orientation of the device (horizontal or vertical)
- Volume of the ambient air surrounding the device under test and airflow
- Whether other surfaces are in close proximity to the device being tested

The device power dissipation,  $P_D$ , is a function of the charge rate and the voltage drop across the internal PowerFET. It can be calculated from the following equation when a battery pack is being charged:

$$P_D = (V_{IN} - V_{OUT}) \times I_{OUT}$$

Due to the charge profile of LiFePO<sub>4</sub> batteries the maximum power dissipation is typically seen at the beginning of the charge cycle when the battery voltage is at its lowest. See the charging profile, [Figure 13](#). If the board thermal design is not adequate the programmed fast charge rate current may not be achieved under maximum input voltage and minimum battery voltage, as the thermal loop can be active, effectively reducing the charge current to avoid excessive IC junction temperature.

### PCB LAYOUT CONSIDERATIONS

It is important to pay special attention to the PCB layout. The following provides some guidelines:

- To obtain optimal performance, the decoupling capacitor from IN to GND (thermal pad) and the output filter capacitors from OUT to GND (thermal pad) should be placed as close as possible to the bq25070, with short trace runs to both IN, OUT and GND (thermal pad).

- All low-current GND connections should be kept separate from the high-current charge or discharge paths from the battery. Use a single-point ground technique incorporating both the small signal ground path and the power ground path.
- The high current charge paths into IN pin and from the OUT pin must be sized appropriately for the maximum charge current in order to avoid voltage drops in these traces.
- The bq25070 is packaged in a thermally enhanced SON package. The package includes a thermal pad to provide an effective thermal contact between the IC and the printed circuit board (PCB); this thermal pad is also the main ground connection for the device. Connect the thermal pad to the PCB ground connection. Full PCB design guidelines for this package are provided in the application note entitled: *QFN/SON PCB Attachment Application Note* ([SLUA271](#)).

**PACKAGING INFORMATION**

Orderable Device	Status (1)	Package Type	Package Drawing	Pins	Package Qty	Eco Plan (2)	Lead finish/ Ball material (6)	MSL Peak Temp (3)	Op Temp (°C)	Device Marking (4/5)	Samples
BQ25070DQCR	ACTIVE	WSON	DQC	10	3000	RoHS & Green	NIPDAU	Level-2-260C-1 YEAR	-40 to 85	QUS	<a href="#">Samples</a>
BQ25070DQCT	ACTIVE	WSON	DQC	10	250	RoHS & Green	NIPDAU	Level-2-260C-1 YEAR	-40 to 85	QUS	<a href="#">Samples</a>

(1) The marketing status values are defined as follows:

**ACTIVE:** Product device recommended for new designs.

**LIFEBUY:** TI has announced that the device will be discontinued, and a lifetime-buy period is in effect.

**NRND:** Not recommended for new designs. Device is in production to support existing customers, but TI does not recommend using this part in a new design.

**PREVIEW:** Device has been announced but is not in production. Samples may or may not be available.

**OBsolete:** TI has discontinued the production of the device.

(2) **RoHS:** TI defines "RoHS" to mean semiconductor products that are compliant with the current EU RoHS requirements for all 10 RoHS substances, including the requirement that RoHS substance do not exceed 0.1% by weight in homogeneous materials. Where designed to be soldered at high temperatures, "RoHS" products are suitable for use in specified lead-free processes. TI may reference these types of products as "Pb-Free".

**RoHS Exempt:** TI defines "RoHS Exempt" to mean products that contain lead but are compliant with EU RoHS pursuant to a specific EU RoHS exemption.

**Green:** TI defines "Green" to mean the content of Chlorine (Cl) and Bromine (Br) based flame retardants meet JS709B low halogen requirements of <=1000ppm threshold. Antimony trioxide based flame retardants must also meet the <=1000ppm threshold requirement.

(3) MSL, Peak Temp. - The Moisture Sensitivity Level rating according to the JEDEC industry standard classifications, and peak solder temperature.

(4) There may be additional marking, which relates to the logo, the lot trace code information, or the environmental category on the device.

(5) Multiple Device Markings will be inside parentheses. Only one Device Marking contained in parentheses and separated by a "~" will appear on a device. If a line is indented then it is a continuation of the previous line and the two combined represent the entire Device Marking for that device.

(6) Lead finish/Ball material - Orderable Devices may have multiple material finish options. Finish options are separated by a vertical ruled line. Lead finish/Ball material values may wrap to two lines if the finish value exceeds the maximum column width.

**Important Information and Disclaimer:**The information provided on this page represents TI's knowledge and belief as of the date that it is provided. TI bases its knowledge and belief on information provided by third parties, and makes no representation or warranty as to the accuracy of such information. Efforts are underway to better integrate information from third parties. TI has taken and continues to take reasonable steps to provide representative and accurate information but may not have conducted destructive testing or chemical analysis on incoming materials and chemicals. TI and TI suppliers consider certain information to be proprietary, and thus CAS numbers and other limited information may not be available for release.

In no event shall TI's liability arising out of such information exceed the total purchase price of the TI part(s) at issue in this document sold by TI to Customer on an annual basis.

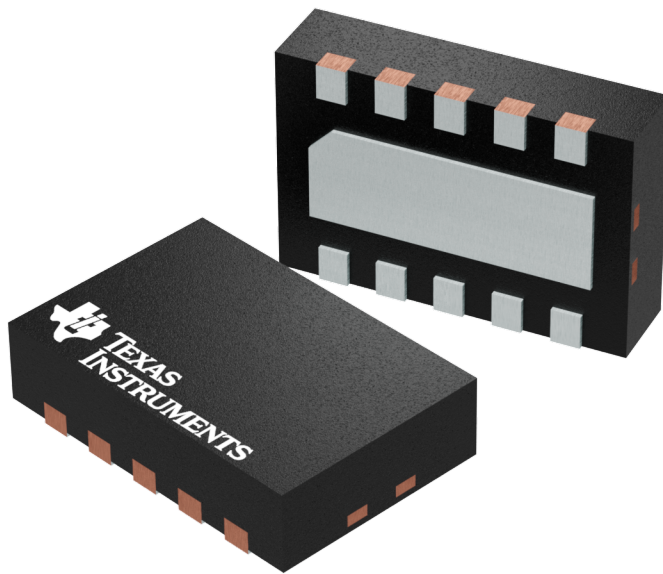


## GENERIC PACKAGE VIEW

DQC 10

WSO - 0.8 mm max height

PLASTIC SMALL OUTLINE - NO LEAD



Images above are just a representation of the package family, actual package may vary.  
Refer to the product data sheet for package details.

4209674/B

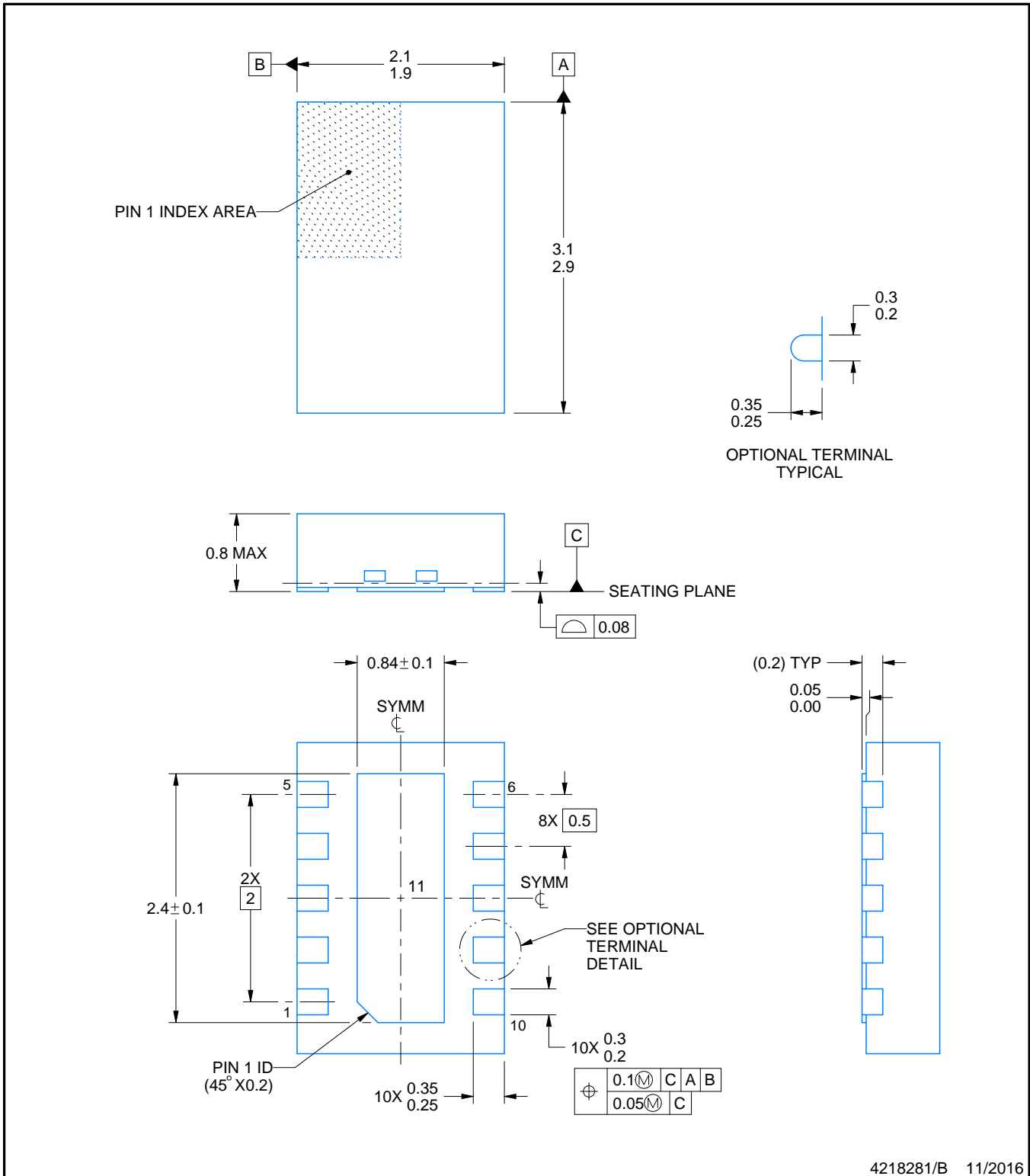
# DQC0010A



# PACKAGE OUTLINE

## WSO - 0.8mm max height

PLASTIC SMALL OUTLINE - NO LEAD



4218281/B 11/2016

**NOTES:**

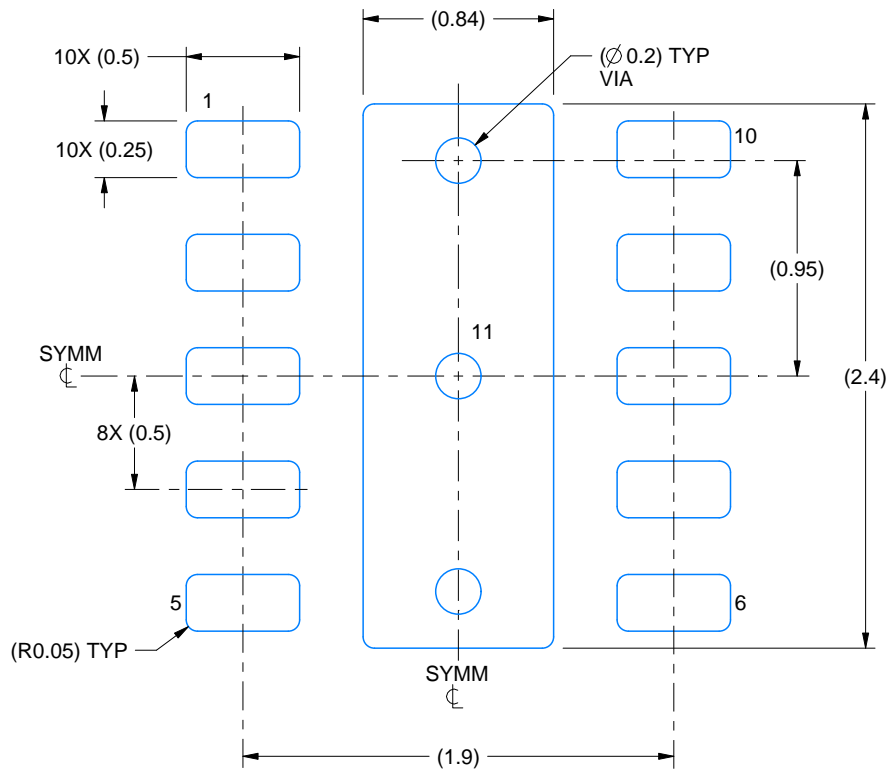
1. All linear dimensions are in millimeters. Any dimensions in parenthesis are for reference only. Dimensioning and tolerancing per ASME Y14.5M.
2. This drawing is subject to change without notice.
3. The package thermal pad must be soldered to the printed circuit board for thermal and mechanical performance.

# EXAMPLE BOARD LAYOUT

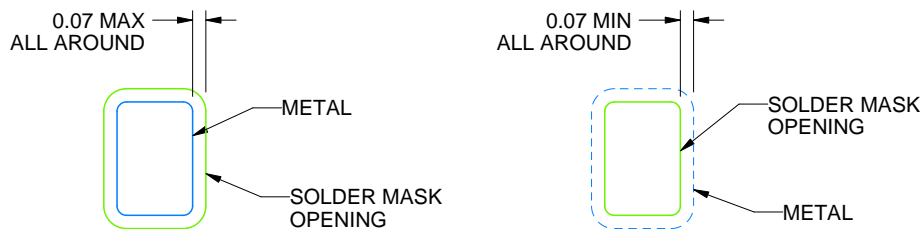
DQC0010A

WSO - 0.8mm max height

PLASTIC SMALL OUTLINE - NO LEAD



LAND PATTERN EXAMPLE  
SCALE: 30X



NON SOLDER MASK  
DEFINED  
(PREFERRED)

SOLDER MASK  
DEFINED

SOLDER MASK DETAILS

4218281/B 11/2016

NOTES: (continued)

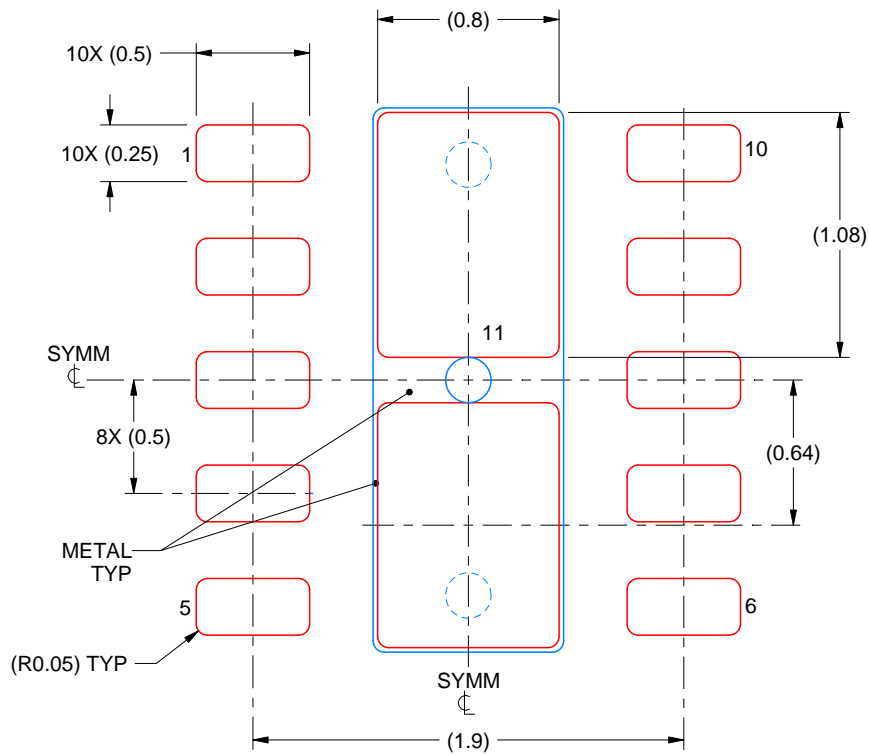
4. This package is designed to be soldered to a thermal pad on the board. For more information, see Texas Instruments literature number SLUA271 ([www.ti.com/lit/sluea271](http://www.ti.com/lit/sluea271)).
5. Vias are optional depending on application, refer to device data sheet. If any vias are implemented, refer to their locations shown on this view. It is recommended that vias under paste be filled, plugged or tented.

# EXAMPLE STENCIL DESIGN

DQC0010A

WSN - 0.8mm max height

PLASTIC SMALL OUTLINE - NO LEAD



SOLDER PASTE EXAMPLE  
BASED ON 0.125 mm THICK STENCIL

EXPOSED PAD 11:  
86% PRINTED SOLDER COVERAGE BY AREA UNDER PACKAGE  
SCALE: 30X

4218281/B 11/2016

NOTES: (continued)

6. Laser cutting apertures with trapezoidal walls and rounded corners may offer better paste release. IPC-7525 may have alternate design recommendations.

## 重要声明和免责声明

TI 均以“原样”提供技术性及其可靠性数据（包括数据表）、设计资源（包括参考设计）、应用或其他设计建议、网络工具、安全信息和其他资源，不保证其中不含任何瑕疵，且不做任何明示或暗示的担保，包括但不限于对适销性、适合某特定用途或不侵犯任何第三方知识产权的暗示担保。

所述资源可供专业开发人员应用TI 产品进行设计使用。您将对以下行为独自承担全部责任：(1) 针对您的应用选择合适的TI 产品；(2) 设计、验证并测试您的应用；(3) 确保您的应用满足相应标准以及任何其他安全、安保或其他要求。所述资源如有变更，恕不另行通知。TI 对您使用所述资源的授权仅限于开发资源所涉及TI 产品的相关应用。除此之外不得复制或展示所述资源，也不提供其它TI 或任何第三方的知识产权授权许可。如因使用所述资源而产生任何索赔、赔偿、成本、损失及债务等，TI 对此概不负责，并且您须赔偿由此对TI 及其代表造成的损害。

TI 所提供产品均受TI 的销售条款 (<http://www.ti.com.cn/zh-cn/legal/termsofsale.html>) 以及 [ti.com.cn](http://www.ti.com.cn) 上或随附TI 产品提供的其他可适用条款的约束。TI 提供所述资源并不扩展或以其他方式更改TI 针对TI 产品所发布的可适用的担保范围或担保免责声明。

邮寄地址：上海市浦东新区世纪大道 1568 号中建大厦 32 楼，邮政编码：200122

Copyright © 2020 德州仪器半导体技术（上海）有限公司