

## 5 通道节省空间静电放电 (ESD) 保护器件

 查询样品: **TPD5E003**

### 特性

- 为低压输入输出 (IO) 接口提供系统级的 ESD 保护
- **IEC 61000-4-2 级别 4**
  - $\pm 15\text{kV}$  (接触放电)
  - $\pm 15\text{kV}$  (空气间隙放电)
- 典型 IO 电容 **7pF ( $V_{IO}=2.5\text{V}$ )**
- 直流 (DC) 击穿电压 **6V** (最小值)
- 低泄漏电流 **100nA** (最大值)
- 低 ESD 钳位电压
- 工业温度范围:  **$-40^{\circ}\text{C}$  至  $125^{\circ}\text{C}$**
- **IEC 61000-4-5 (浪涌): 40W (8/20 $\mu\text{s}$  脉冲)**
- 小型、易于走线的 **DPF** 封装

### 应用范围

- **SIM** 卡
- 侧键
- 音频接口
- 存储卡

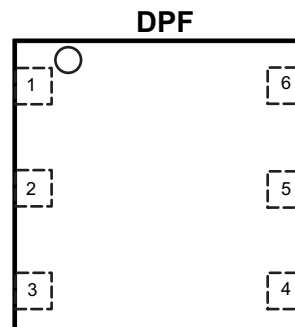

1 mm x 1 mm x 0.4mm  
(0.35-mm pitch)

### 说明

TPD5E003 是一款 5 通道 ESD 保护器件。它提供  $\pm 15\text{KV}$  IEC 接触和  $\pm 15\text{KV}$  空气间隙 ESD 保护。它特有 5 个完全一样的 ESD 钳位二极管, 这些二极管可被用于 5 个单向 (0V 至 5V) I/O 线路或 4 个双向 (-5V 至 5V) I/O 线路。较低的 IO 电容适合于广泛的应用。典型应用领域包括音频线路 (麦克风、耳机和免提电话), SD 接口和袖珍键盘以及其他按钮。

### 订购信息

T <sub>A</sub>	封装 <sup>(1)(2)</sup>		可订购部件号	正面标记
$-40^{\circ}\text{C}$ 至 $125^{\circ}\text{C}$	5000	卷带	TPD5E003DPFR	9Q

(1) 封装图样、热数据和符号可从网站[www.ti.com/packaging](http://www.ti.com/packaging)中获取。

(2) 要获得最新的封装和订购信息, 请见本文档末尾的封装选项附录, 或者浏览 TI 网站[www.ti.com](http://www.ti.com)。



Please be aware that an important notice concerning availability, standard warranty, and use in critical applications of Texas Instruments semiconductor products and disclaimers thereto appears at the end of this data sheet.



These devices have limited built-in ESD protection. The leads should be shorted together or the device placed in conductive foam during storage or handling to prevent electrostatic damage to the MOS gates.

**APPLICATION/FUNCTIONAL BLOCK DIAGRAM**

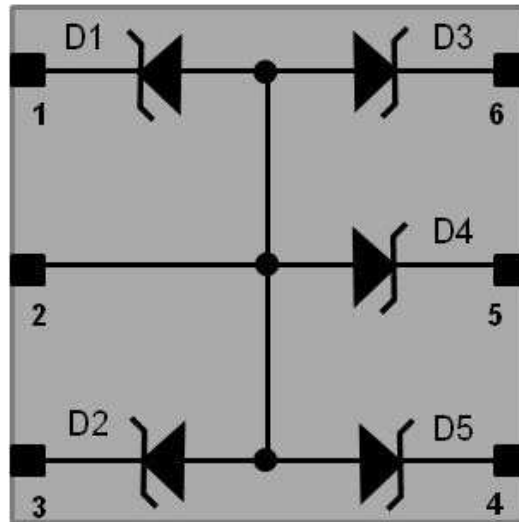

**PIN FUNCTIONS**

PIN NAME	DPF	PIN TYPE	DESCRIPTION
I/O	1, 3, 4, 5, 6	I/O	ESD Protected channel
GND	2	GND	Ground

**ABSOLUTE MAXIMUM RATINGS**

	MIN	MAX	UNIT
IO voltage tolerance		5.5	V
Operating temperature range	-40	125	°C
Storage temperature	-55	150	°C
IEC 61000-4-2 contact ESD		±15	kV
IEC 61000-4-2 air-gap ESD		±15	kV
I <sub>PP</sub> , peak pulse current (t <sub>p</sub> = 8/20µs)		3	A
P <sub>PP</sub> , peak pulse power (t <sub>p</sub> = 8/20µs)		40	W

**ELECTRICAL CHARACTERISTICS**

PARAMETER	TEST CONDITION	MIN	TYP	MAX	UNIT
V <sub>RWM</sub> Reverse stand-off voltage	I <sub>l</sub> = 0.1 µA			5.0	V
I <sub>LEAK</sub> Leakage Current	Pin 1, 3, 4, 5, or 6 = 5V, Pin 2 = 0V		10	100	nA
V <sub>Clamp</sub> Clamp voltage with ESD strike	I <sub>PP</sub> = 6A, TLP, Dx pin to GND, T <sub>A</sub> = 25 °C		13	15.6	V
	I <sub>PP</sub> = 10 A, TLP, Dx pin to GND, T <sub>A</sub> = 25 °C		16.3	19.5	V
R <sub>DYN</sub> Dynamic resistance	I <sub>TLP</sub> = 6A to 10 A, Dx pin to GND, T <sub>A</sub> = 25 °C		0.8	1	Ω
	I <sub>TLP</sub> = 6A to 10 A, GND to Dx pin, T <sub>A</sub> = 25 °C		0.3	0.4	Ω
C <sub>IO</sub> IO capacitance	V <sub>IO</sub> = 2.5V, 1 MHz, T <sub>A</sub> = 25 °C	5.6	7	8.4	pF
	V <sub>IO</sub> = 0V, 1 MHz, T <sub>A</sub> = 25 °C	8	10	12	pF
V <sub>BR</sub> Break-down voltage	I <sub>IO</sub> = 1 mA	6.0	7	8.5	V

APPLICATION INFORMATION

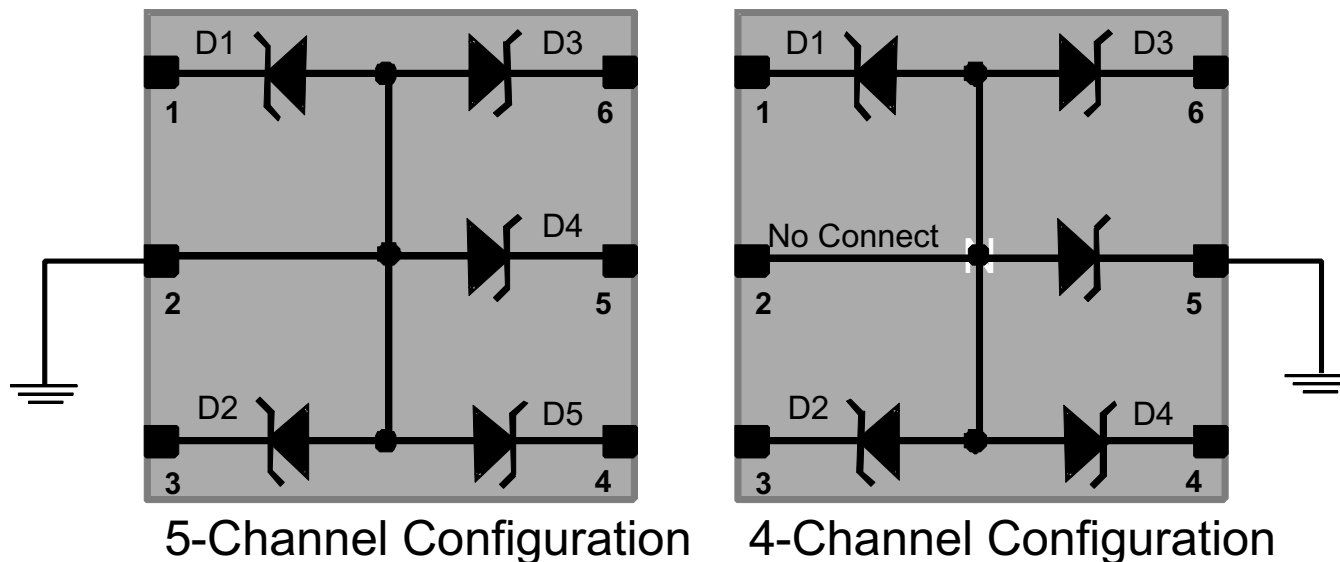

Figure 1. Application Diagram

The TPD5E003 offers 5 identical unidirectional ESD protection channels. To use all 5 channels, the recommended configuration is shown in [Figure 1](#). The TPD5E003 can also be used as 4 identical bidirectional ESD protection channels. To do so, pin 5 would be connected to ground, with pin 1, 3, 4, and 6 connected to the I/O to be protected. In the bidirectional configuration, IO capacitance is reduced by half and the breakdown voltage is doubled.

TYPICAL CHARACTERISTICS

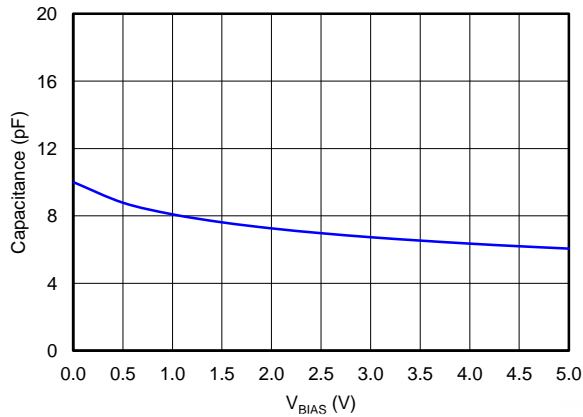

Figure 2. Capacitance vs DC Bias Voltage

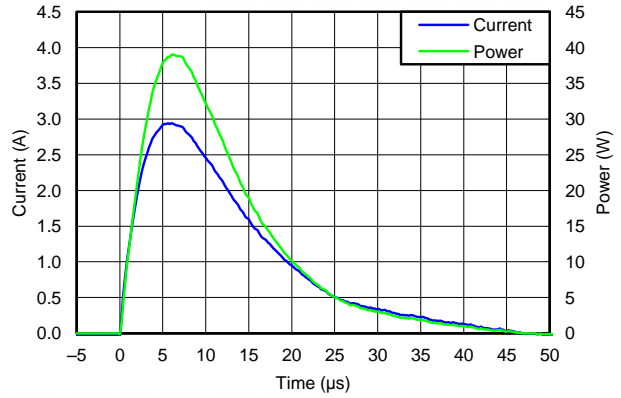

Figure 3. Surge Plot ( $t_p = 8/20\mu s$ ), Pin Dx to GND

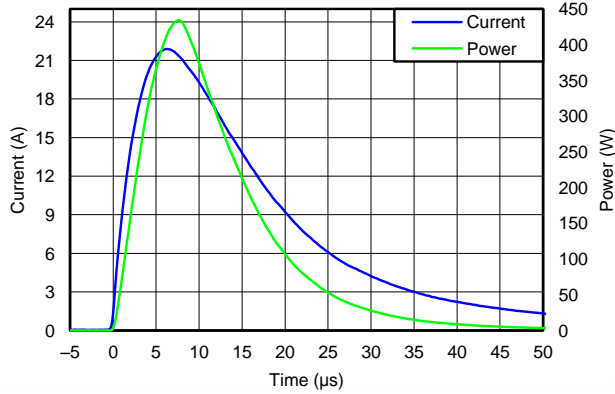

Figure 4. Surge Plot ( $t_p = 8/20\mu s$ ), Pin GND to Dx

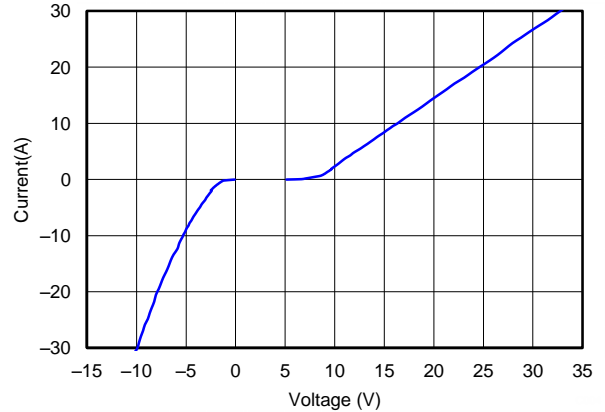

Figure 5. 30 Amps TLP Plot

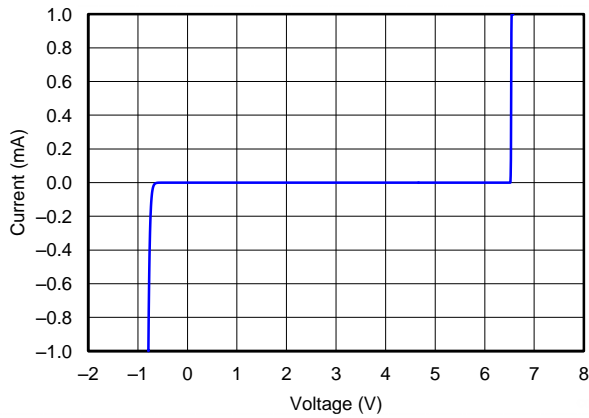

Figure 6. DC SWEEP V-I Curve

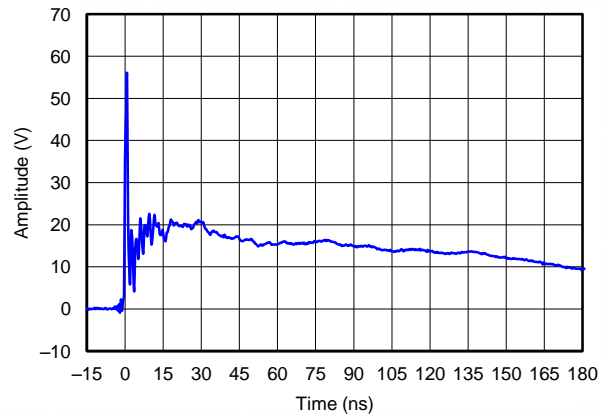
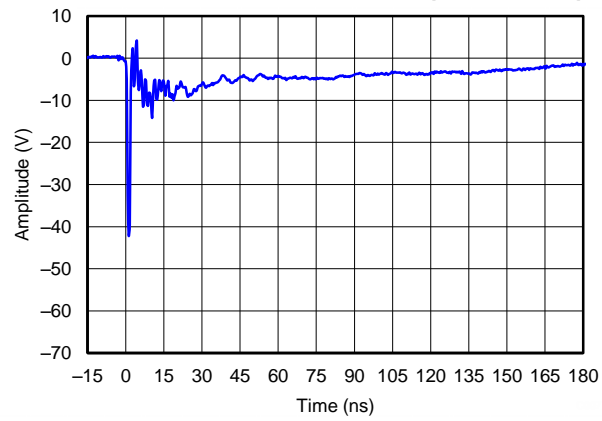

Figure 7. IEC 61000-4-2 Clamping Voltage, +8kV Contact

**TYPICAL CHARACTERISTICS (continued)**



**Figure 8. IEC 61000-4-2 Clamping Voltage, -8kV Contact**

## REVISION HISTORY

Changes from Original (December 2012) to Revision A	Page
• Added IO voltage tolerance to the ABSOLUTE MAXIMUM RATINGS table. ....	2
• Added MAX values to parameters in the ELECTRICAL CHARACTERISTICS table. ....	2

## PACKAGING INFORMATION

Orderable Device	Status (1)	Package Type	Package Drawing	Pins	Package Qty	Eco Plan (2)	Lead finish/ Ball material (6)	MSL Peak Temp (3)	Op Temp (°C)	Device Marking (4/5)	Samples
TPD5E003DPFR	ACTIVE	X2SON	DPF	6	5000	RoHS & Green	NIPDAU	Level-1-260C-UNLIM	-40 to 125	9Q	<b>Samples</b>

(1) The marketing status values are defined as follows:

**ACTIVE:** Product device recommended for new designs.

**LIFEBUY:** TI has announced that the device will be discontinued, and a lifetime-buy period is in effect.

**NRND:** Not recommended for new designs. Device is in production to support existing customers, but TI does not recommend using this part in a new design.

**PREVIEW:** Device has been announced but is not in production. Samples may or may not be available.

**OBSOLETE:** TI has discontinued the production of the device.

(2) **RoHS:** TI defines "RoHS" to mean semiconductor products that are compliant with the current EU RoHS requirements for all 10 RoHS substances, including the requirement that RoHS substance do not exceed 0.1% by weight in homogeneous materials. Where designed to be soldered at high temperatures, "RoHS" products are suitable for use in specified lead-free processes. TI may reference these types of products as "Pb-Free".

**RoHS Exempt:** TI defines "RoHS Exempt" to mean products that contain lead but are compliant with EU RoHS pursuant to a specific EU RoHS exemption.

**Green:** TI defines "Green" to mean the content of Chlorine (Cl) and Bromine (Br) based flame retardants meet JS709B low halogen requirements of <=1000ppm threshold. Antimony trioxide based flame retardants must also meet the <=1000ppm threshold requirement.

(3) MSL, Peak Temp. - The Moisture Sensitivity Level rating according to the JEDEC industry standard classifications, and peak solder temperature.

(4) There may be additional marking, which relates to the logo, the lot trace code information, or the environmental category on the device.

(5) Multiple Device Markings will be inside parentheses. Only one Device Marking contained in parentheses and separated by a "-" will appear on a device. If a line is indented then it is a continuation of the previous line and the two combined represent the entire Device Marking for that device.

(6) Lead finish/Ball material - Orderable Devices may have multiple material finish options. Finish options are separated by a vertical ruled line. Lead finish/Ball material values may wrap to two lines if the finish value exceeds the maximum column width.

**Important Information and Disclaimer:** The information provided on this page represents TI's knowledge and belief as of the date that it is provided. TI bases its knowledge and belief on information provided by third parties, and makes no representation or warranty as to the accuracy of such information. Efforts are underway to better integrate information from third parties. TI has taken and continues to take reasonable steps to provide representative and accurate information but may not have conducted destructive testing or chemical analysis on incoming materials and chemicals. TI and TI suppliers consider certain information to be proprietary, and thus CAS numbers and other limited information may not be available for release.

In no event shall TI's liability arising out of such information exceed the total purchase price of the TI part(s) at issue in this document sold by TI to Customer on an annual basis.

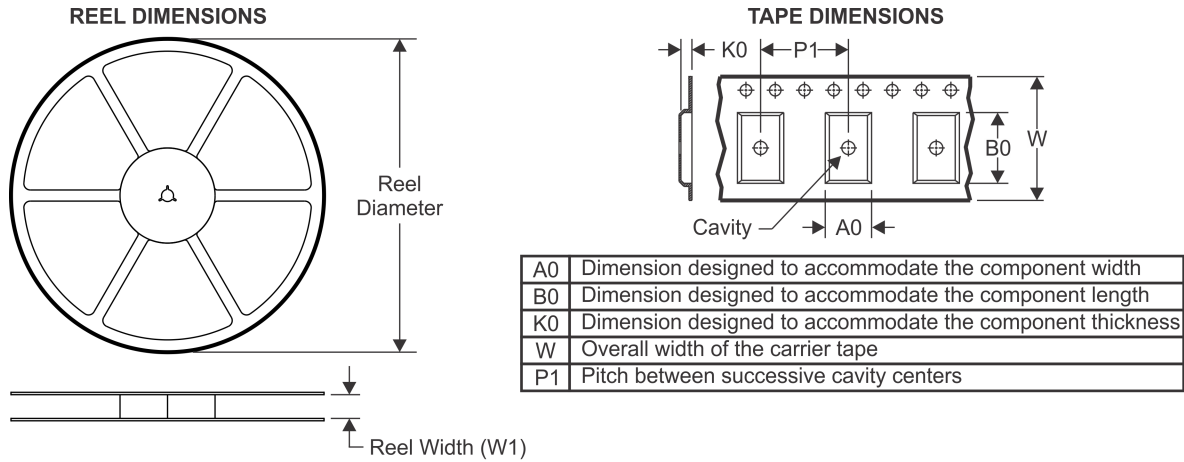
**TAPE AND REEL INFORMATION**

**QUADRANT ASSIGNMENTS FOR PIN 1 ORIENTATION IN TAPE**

\*All dimensions are nominal

Device	Package Type	Package Drawing	Pins	SPQ	Reel Diameter (mm)	Reel Width W1 (mm)	A0 (mm)	B0 (mm)	K0 (mm)	P1 (mm)	W (mm)	Pin1 Quadrant
TPD5E003DPFR	X2SON	DPF	6	5000	180.0	9.5	1.16	1.16	0.63	4.0	8.0	Q2

TAPE AND REEL BOX DIMENSIONS



\*All dimensions are nominal

Device	Package Type	Package Drawing	Pins	SPQ	Length (mm)	Width (mm)	Height (mm)
TPD5E003DPFR	X2SON	DPF	6	5000	184.0	184.0	19.0

# DPF0006A

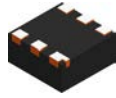

# PACKAGE OUTLINE

## X2SON - 0.4 mm max height

PLASTIC SMALL OUTLINE - NO LEAD

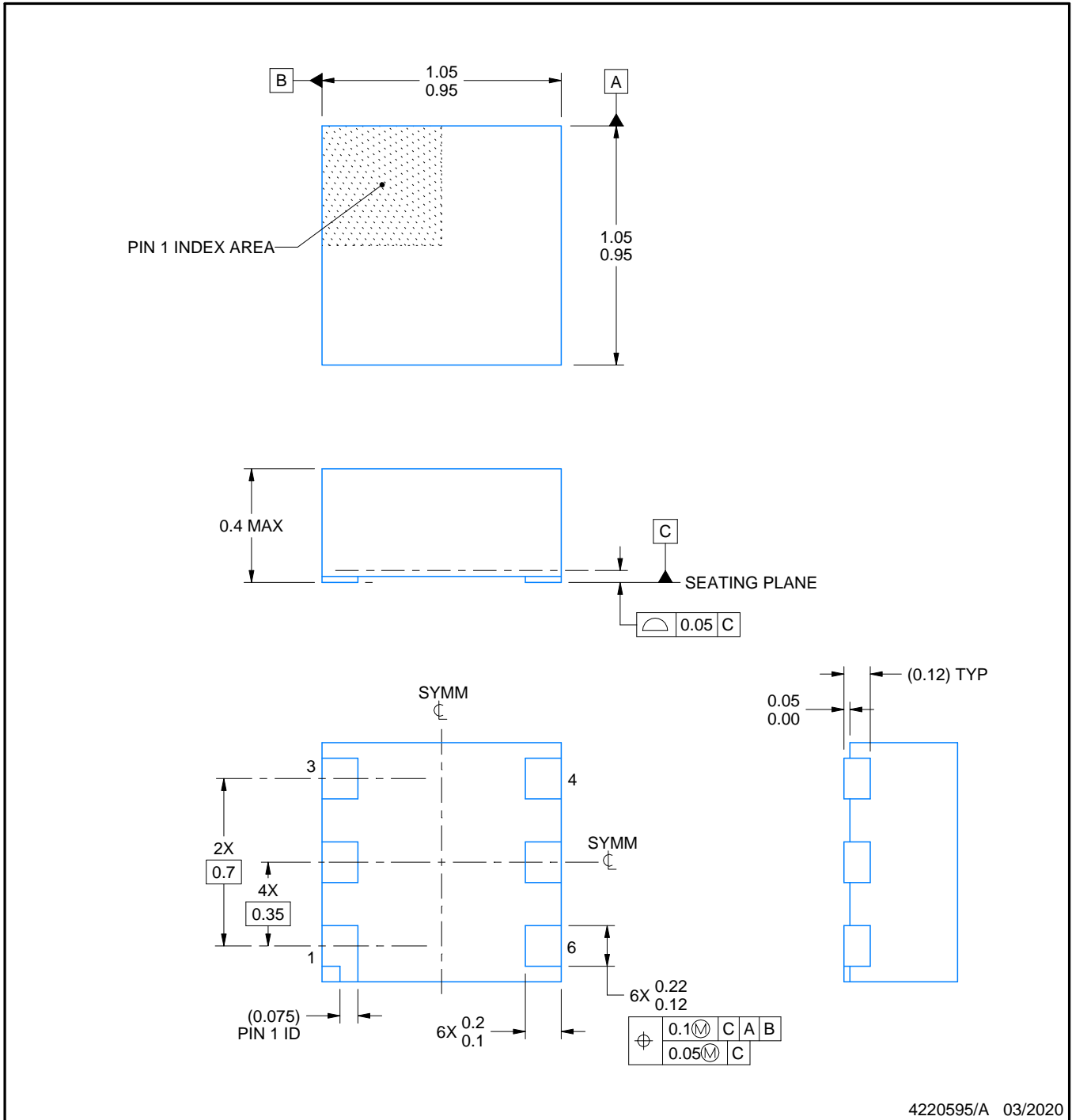

**NOTES:**

1. All linear dimensions are in millimeters. Any dimensions in parenthesis are for reference only. Dimensioning and tolerancing per ASME Y14.5M.
2. This drawing is subject to change without notice.
3. Reference JEDEC registration MO-287, variation X2AAF.

# EXAMPLE BOARD LAYOUT

DPF0006A

X2SON - 0.4 mm max height

PLASTIC SMALL OUTLINE - NO LEAD

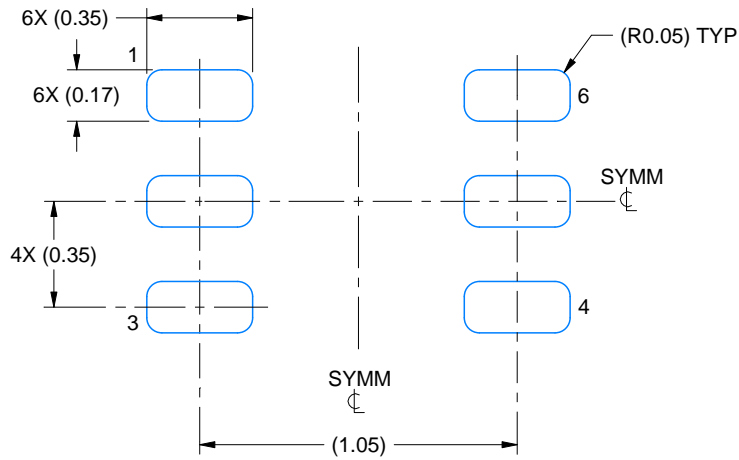

LAND PATTERN EXAMPLE  
EXPOSED METAL SHOWN  
SCALE:40X

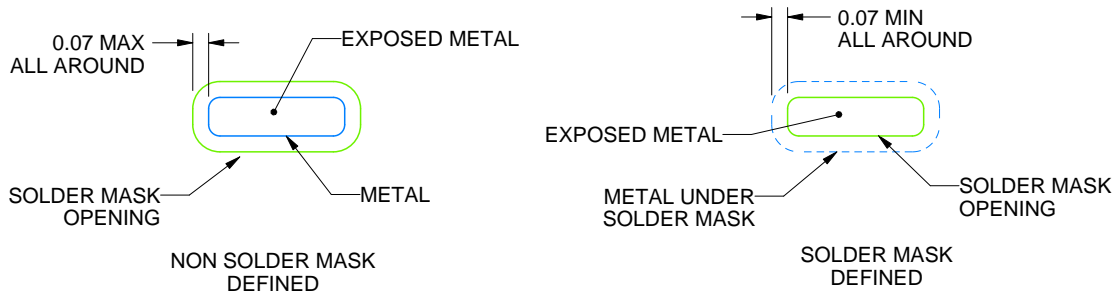

SOLDER MASK DETAILS

4220595/A 03/2020

NOTES: (continued)

4. For more information, see Texas Instruments literature number SLUA271 ([www.ti.com/lit/slua271](http://www.ti.com/lit/slua271)).

# EXAMPLE STENCIL DESIGN

DPF0006A

X2SON - 0.4 mm max height

PLASTIC SMALL OUTLINE - NO LEAD

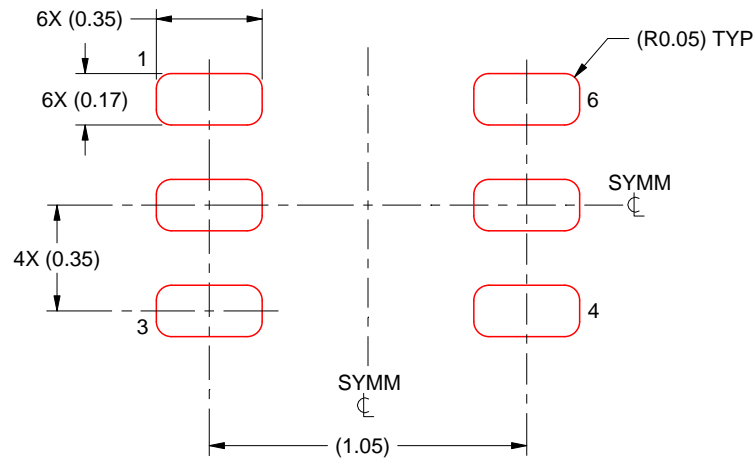

SOLDER PASTE EXAMPLE  
BASED ON 0.1 mm THICK STENCIL

SCALE:40X

4220595/A 03/2020

4. Laser cutting apertures with trapezoidal walls and rounded corners may offer better paste release. IPC-7525 may have alternate design recommendations.

## 重要声明和免责声明

TI 均以“原样”提供技术性 & 可靠性数据（包括数据表）、设计资源（包括参考设计）、应用或其他设计建议、网络工具、安全信息和其他资源，不保证其中不含任何瑕疵，且不做任何明示或暗示的担保，包括但不限于对适销性、适合某特定用途或不侵犯任何第三方知识产权的暗示担保。

所述资源可供专业开发人员应用 TI 产品进行设计使用。您将对以下行为独自承担全部责任：(1) 针对您的应用选择合适的 TI 产品；(2) 设计、验证并测试您的应用；(3) 确保您的应用满足相应标准以及任何其他安全、安保或其他要求。所述资源如有变更，恕不另行通知。TI 对您使用所述资源的授权仅限于开发资源所涉及 TI 产品的相关应用。除此之外不得复制或展示所述资源，也不提供其它 TI 或任何第三方的知识产权授权许可。如因使用所述资源而产生任何索赔、赔偿、成本、损失及债务等，TI 对此概不负责，并且您须赔偿由此对 TI 及其代表造成的损害。

TI 所提供产品均受 TI 的销售条款 (<http://www.ti.com.cn/zh-cn/legal/termsofsale.html>) 以及 [ti.com.cn](http://www.ti.com.cn) 上或随附 TI 产品提供的其他可适用条款的约束。TI 提供所述资源并不扩展或以其他方式更改 TI 针对 TI 产品所发布的可适用的担保范围或担保免责声明。

邮寄地址：上海市浦东新区世纪大道 1568 号中建大厦 32 楼，邮政编码：200122

Copyright © 2020 德州仪器半导体技术（上海）有限公司