

UCC25640x LLC Resonant Controller with Ultra-Low Audible Noise and Standby Power

1 Features

- Optimized low power mode and burst mode algorithm
 - Burst mode with Soft-ON and Soft-OFF periods
 - Minimized audible noise at no load and standby
 - User option to disable burst mode
 - Opto-coupler low power operation
 - Efficiency performance exceeds DoE Level VI and EU CoC Tier-2 External Power Supply Standards
- Hybrid hysteretic control (HHC)
 - Best-in-class transient response
 - Fast exit from burst mode
- Robust adaptive dead-time control
- Integrated high-voltage gate driver with 0.6 A source and 1.2 A sink capability
- Robust capacitive region (ZCS) avoidance scheme
- Over temperature, output over voltage, input under voltage protection, three levels of over current protection
- Integrated high voltage startup function
- Active X-capacitor discharge function

2 Applications

- SMPS power supply for TV
- Lighting
- AC-DC adapter
- Power tools
- Medical power supply
- Multi-functional printer
- Enterprise and cinema projector
- PC power supply
- Gaming console power supply

3 Description

The UCC25640x is a fully featured LLC controller with integrated high-voltage gate driver. It has been designed to pair with a PFC controller to provide a complete power system using a minimum of external components. The resulting power system is designed to meet the most stringent requirements for standby power without the need for a separate standby power converter.

UCC25640x provides a highly efficient burst mode with soft-on and soft-off periods to minimize audible noise at standby operation. The burst power level and hysteresis are programmable, simplifying the optimization of efficiency and burst mode operation. Burst mode can also be disabled through pin configuration. UCC25640x uses hybrid hysteretic control to provide best in class line and load transient response.

UCC25640x includes a range of features designed to make LLC converter operation well controlled and protected. It can be used with UCC28056 or UCC28064A PFC controllers, along with UCC24624 synchronous rectifier controller to offer a complete power supply solution.

Device Information

PART NUMBER	PACKAGE	BODY SIZE (NOM)
UCC256402	SOIC	9.9 mm x 3.9 mm
UCC256403	SOIC	9.9 mm x 3.9 mm
UCC256404	SOIC	9.9 mm x 3.9 mm

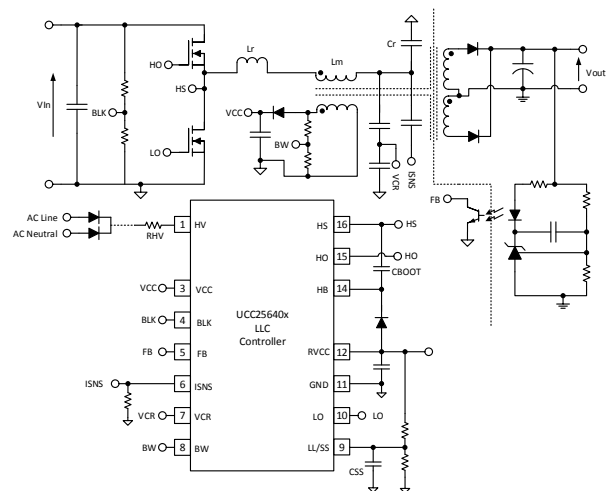

Simplified Schematic



Table of Contents

1 Features	1	7.2 Functional Block Diagram.....	17
2 Applications	1	7.3 Feature Description.....	18
3 Description	1	7.4 Device Functional Modes.....	32
4 Revision History	2	8 Power Supply Recommendations	67
Device Comparison Table	3	8.1 VCC Pin Capacitor.....	67
5 Pin Configuration and Functions	3	8.2 Boot Capacitor.....	67
Pin Functions.....	3	8.3 RVCC Pin Capacitor.....	68
6 Specifications	5	9 Layout	69
6.1 Absolute Maximum Ratings.....	5	9.1 Layout Guidelines.....	69
6.2 ESD Ratings.....	5	9.2 Layout Example.....	70
6.3 Recommended Operating Conditions.....	6	10 Device and Documentation Support	72
6.4 Thermal Information.....	6	10.1 Documentation Support.....	72
6.5 Electrical Characteristics.....	6	10.2 Related Links.....	72
6.6 Switching Characteristics.....	10	10.3 Receiving Notification of Documentation Updates..	72
6.7 Typical Characteristics.....	11	10.4 Community Resources.....	72
7 Detailed Description	15	10.5 Trademarks.....	72
7.1 Overview.....	15		

4 Revision History

NOTE: Page numbers for previous revisions may differ from page numbers in the current version.

Changes from Revision D (September 2020) to Revision E (February 2021)	Page
• Updated Absolute Maximum Ratings HV, HB Input Voltage from 640 V to 700 V maximum.....	5

Changes from Revision C (March 2020) to Revision D (September 2020)	Page
• Added update to Device Comparison Table.....	3

Changes from Revision B (November 2019) to Revision C (March 2020)	Page
• Changed package description from SOIC (14) to SOIC.....	1
• Changed name of Pin 2 from Missing to Removed.....	3
• Changed name of Pin 13 from Missing to Removed.....	3
• Added description of BLK OVP thresholds.....	24
• Added input over voltage protection description.....	30
• Changed R_{FB} to R_{LL}	37
• Added update to Layout Example.....	70

Changes from Revision A (August 2019) to Revision B (November 2019)	Page
• Changed marketing status from Advance Information to production data.....	1

Device Comparison Table

Device	Integrated High Voltage Startup	Integrated X-Capacitor Discharge	Requires External Bias Supply	Burst Soft On and Soft Off	BLK OVP	BW OVP Mode
UCC256402	Yes	No	No	No	No	Restart
UCC256402A	Yes	No	No	No	Yes	Restart
UCC256403	No	No	Yes	Yes	No	Restart
UCC256403A	No	No	Yes	No	No	Latch
UCC256404	Yes	Yes	No	Yes	No	Restart
UCC256404A	Yes	Yes	No	No	No	Latch
UCC256404B ⁽¹⁾	Yes	Yes	No	Yes	No	Restart

(1) The X capacitor discharge feature of this device has not been tested by certification agency and was qualified by similarity under the existing UCC25640x certification

5 Pin Configuration and Functions

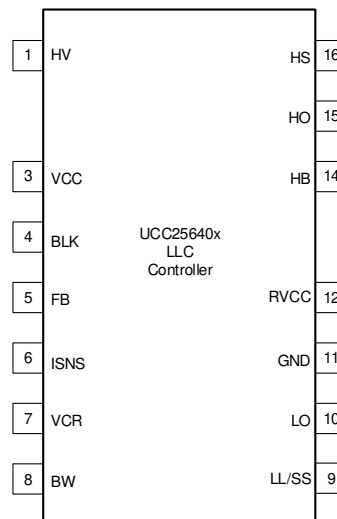

Figure 5-1. DDB Package 16-Pin SOIC (Pins 2, 13 removed) Top View

Pin Functions

PIN		I/O	DESCRIPTION
NAME	NO.		
BLK	4	I	This pin is used to sense the LLC stage input voltage level. A resistor divider should be used to attenuate the signal before it is applied to this pin. The voltage level on this pin will determine when the LLC converter starts/stops switching.
BW	8	I	This pin is used to sense the output voltage through the bias winding. The sensed voltage is used for output over voltage protection. During startup, the pin is also used to program the ratio between the two burst mode thresholds (BMT_L and BMT_H).
FB	5	I	LLC stage control feedback input. The amount of current sourced from this pin will determine the LLC input power level.
GND	11	G	Ground reference for all signals.
HB	14	I	High-side gate-drive floating supply voltage. The bootstrap capacitor is connected between this pin and HS pin. A high voltage, high speed diode should be connected from RVCC to this pin to supply power to the high-side gate-driver during the period when the low-side MOSFET is conducting.
HO	15	O	High-side floating gate-drive output.
HS	16	I	High-side gate-drive floating ground. Current return for the high-side gate-drive current.

PIN		I/O	DESCRIPTION
NAME	NO.		
HV	1	I	Connects to internal HV startup JFET. For UCC256402 and UCC256404, this pin provides start up power for both PFC and LLC stage. This pin also monitors the AC line voltage for x-capacitor discharge function. For UCC256403, this pin needs to be connected to ground.
ISNS	6	I	Resonant current sense. The resonant capacitor voltage is differentiated with a first order filter to measure the resonant current.
LL/SS	9	I	The capacitance value connected from this pin to ground will impact the duration of the soft-start period. The resistor divider connected to the pin will define the initial voltage applied on the pin for startup. After system startup, this pin is used to program the burst mode threshold.
LO	10	O	Low-side gate-drive output.
Removed	2	N/A	Functional creepage and clearance
Removed	13	N/A	Functional creepage and clearance
RVCC	12	P	Regulated 13-V supply. This pin is used to supply the gate driver and PFC controller.
VCC	3	P	Supply input.
VCR	7	I	Resonant capacitor voltage sense.

6 Specifications

6.1 Absolute Maximum Ratings

Over operating free-air temperature range (unless otherwise noted), all voltages are with respect to GND, currents are positive into and negative out of the specified terminal.⁽¹⁾

		MIN	MAX	UNIT
Input voltage	HV, HB	-0.3	700	V
	BLK, LL/SS	-0.55	7.2	V
	VCR	-0.8 Internally Clamped		V
	VCC	-0.55	30	V
	BW, ISNS	-5	7.2	V
	HB - HS (For UCC256402, UCC256402A, UCC256403, UCC256403A, UCC256404, UCC256404A)	-0.3	17	V
	HB - HS (For UCC256404B)	-0.3	25	V
RVCC output voltage	DC	-0.3	17	V
HO output voltage	DC	HS – 0.3	HB + 0.3	V
	Transient, less than 100 ns	HS – 2	HB + 0.3	
LO output voltage	DC	-0.3	RVCC + 0.3	V
	Transient, less than 100 ns	-2	RVCC + 0.3	
Floating ground slew rate	dV_{HS}/dt	-50	50	V/ns
HO, LO pulsed current	I_{OUT_PULSED}	-0.6	1.2	A
Junction temperature range	T_J	-40	150	°C
Storage temperature range, T_{stg}	T_{stg}	-65	150	
Lead temperature	Soldering, 10 second		300	
	Reflow		260	

- (1) Stresses beyond those listed under Absolute Maximum Ratings may cause permanent damage to the device. These are stress ratings only, which do not imply functional operation of the device at these or any other conditions beyond those indicated under Recommended Operating Conditions. Exposure to absolute-maximum-rated conditions for extended periods may affect device reliability.

6.2 ESD Ratings

			VALUE	UNIT
$V_{(ESD)}$	Electrostatic discharge	Human body model (HBM), per ANSI/ESDA/JEDEC JS-001, HV, HO, HS, HB pins ⁽¹⁾	±1000	V
		Human body model (HBM), per ANSI/ESDA/JEDEC JS-001, all other pins ⁽¹⁾	±2000	
		Charged device model (CDM), per JEDEC specification JESD22-C101, all pins ⁽²⁾	±500	

- (1) JEDEC document JEP155 states that 500-V HBM allows safe manufacturing with a standard ESD control process.
 (2) JEDEC document JEP157 states that 250-V CDM allows safe manufacturing with a standard ESD control process.

6.3 Recommended Operating Conditions

All voltages are with respect to GND, $-40^{\circ}\text{C} < T_J = T_A < 125^{\circ}\text{C}$, currents are positive into and negative out of the specified terminal, unless otherwise noted.

		MIN	NOM	MAX	UNIT
HV, HS	Input voltage			600	V
V _{CC}	Supply voltage	13	15	26	V
HB - HS	Driver bootstrap voltage	10	12	16	V
C _B	Ceramic bypass capacitor from HB to HS	0.1		5	μF
C _{SS}	Soft start pin capacitor	4.7		470	nF
C _{RVCC}	RVCC pin decoupling capacitor	4.7			μF
I _{RVCCMAX}	Maximum output current of RVCC ⁽¹⁾			100	mA
T _A	Operating ambient temperature	-40		125	°C

(1) Not tested in production. Ensured by characterization

6.4 Thermal Information

THERMAL METRIC ⁽¹⁾		UCC25640x	UNIT
		D (SOIC)	
		14 PINS	
R _{θJA}	Junction-to-ambient thermal resistance	74.7	°C/W
R _{θJC(top)}	Junction-to-case (top) thermal resistance	30.7	°C/W
R _{θJB}	Junction-to-board thermal resistance	31.8	°C/W
Ψ _{JT}	Junction-to-top characterization parameter	4.4	°C/W
Ψ _{JB}	Junction-to-board characterization parameter	31.4	°C/W

(1) For more information about traditional and new thermal metrics, see the Semiconductor and IC Package Thermal Metrics application report, SPRA953.

6.5 Electrical Characteristics

All voltages are with respect to GND, $-40^{\circ}\text{C} < T_J = T_A < 125^{\circ}\text{C}$, V_{CC} = 15 V, currents are positive into and negative out of the specified terminal, unless otherwise noted.

PARAMETER		TEST CONDITIONS	MIN	TYP	MAX	UNIT
SUPPLY VOLTAGE						
V _{CCShort}	Below this threshold, use reduced start up current	For UCC256402, UCC256402A, UCC256404, UCC256404A, UCC256404B	0.3	0.5	0.8	V
V _{CCReStartJfet}	Below this threshold, re-enable JFET.	For UCC256402, UCC256402A, UCC256404, UCC256404A, UCC256404B	9.35	9.65	9.95	V
V _{CCStartSelf}	Startup when VCC is above this level	For UCC256402, UCC256402A, UCC256404, UCC256404A, UCC256404B	25	26	28	V
V _{CCStartSwitching}	Startup when VCC is above this level	For UCC256403, UCC256403A		10.9		V
V _{CCUVLOrising}	VCC under voltage lockout voltage (rising)		7.85	8.25	8.70	V
V _{CCUVLOHYS}	VCC under voltage lockout voltage hysteresis		0.15	0.25	0.35	V
SUPPLY CURRENT						
I _{CCSleep}	Current drawn from VCC rail during burst off period		650	780	950	μA

All voltages are with respect to GND, $-40^{\circ}\text{C} < T_J = T_A < 125^{\circ}\text{C}$, $V_{CC} = 15\text{ V}$, currents are positive into and negative out of the specified terminal, unless otherwise noted.

PARAMETER		TEST CONDITIONS	MIN	TYP	MAX	UNIT
I_{CCRun}	Current drawn from VCC Pin while gate is switching. Excluding Gate Current	Dead time = 1 μs maximum dead time	1.8	2.2	2.7	mA
REGULATED SUPPLY						
V_{RVCC}	Regulated supply voltage	$V_{CC} = 15\text{ V}$, no load	12.7	13	13.45	V
	Regulated supply voltage	$V_{CC} = 15\text{ V}$, 100 mA load	12.4	13	13.45	V
	Regulated supply voltage	$V_{CC} = 13\text{ V}$, no load	12.7	12.98		V
	Regulated supply voltage	$V_{CC} = 13\text{ V}$, 30 mA load	12.4	12.6		V
$V_{RVCCUVLO}$	RVCC under voltage lock out voltage		6.5	7	7.5	V
HIGH VOLTAGE STARTUP						
I_{HVLow}	Reduced startup pin current	$V_{HV} = 20\text{ V}$, $V_{CC} = 0\text{ V}$	0.3	0.5	0.65	mA
I_{HVHigh}	Full startup pin current	$V_{HV} = 20\text{ V}$, $V_{CC} = 4\text{ V}$	7.6	10.20	13.5	mA
I_{HVLeak}	HV current source leakage current	$V_{HV} = 600\text{ V}$		1	4	μA
I_{HVZCD}	Highest AC zero crossing detection test current	For UCC256404B	1.0	1.3	1.6	mA
		For UCC256404, UCC256404A	1.4	1.7	2.1	mA
$I_{HVZCDStep}$	AC zero crossing detection test current steps			0.38		mA
$I_{XCAPDischarge}$	X-cap discharge current		8.9	11.5	13.5	mA
$V_{zero-crossing}$	HV pin voltage threshold that zero-crossing is detected		8	9	11	V
$t_{XCAPZCD}$	AC zero crossing detection window length for first three test current stage ⁽¹⁾		10	12	14	ms
$t_{XCAPZCDLast}$	AC zero crossing detection window length for final test current stage ⁽¹⁾		43	46	52	ms
$t_{XCAPIdle}$	AC zero crossing detection idle period length ⁽¹⁾		635	700	772	ms
$t_{XCAPDischarge}$	Time for X-cap discharge current active ⁽¹⁾		327	360	390	ms
$t_{XCAPJFETON}$	Time of first X-cap detection after JFETON ⁽¹⁾			12		ms
BULK VOLTAGE SENSE						
$V_{BLKStart}$	BLK voltage that allows LLC to start switching	For UCC256402, UCC256402A, UCC256403, UCC256403A	2.94	3	3.06	V
		For UCC256404, UCC256404A, UCC256404B	0.98	1	1.02	V
$V_{BLKStop}$	BLK voltage that forces LLC operation to stop	For UCC256402, UCC256402A, UCC256403, UCC256403A	2.15	2.2	2.25	V
		For UCC256404, UCC256404A, UCC256404B	0.88	0.9	0.925	V
$V_{BLKOVPRise}$	BLK over voltage protection rising threshold	For UCC256402A	3.92	4.0	4.08	V
$V_{BLKOVPFall}$	BLK over voltage protection falling threshold	For UCC256402A	3.72	3.8	3.88	V
FEEDBACK PIN						
$R_{FBInternal}$	Internal pull down resistor value		90	100	110	k Ω
I_{FB}	FB internal current source	For UCC256402, UCC256402A, UCC256404, UCC256404A, UCC256404B	73	82	91	μA
		For UCC256403, UCC256403A	147	164	182	μA

All voltages are with respect to GND, $-40^{\circ}\text{C} < T_J = T_A < 125^{\circ}\text{C}$, $V_{CC} = 15\text{ V}$, currents are positive into and negative out of the specified terminal, unless otherwise noted.

PARAMETER		TEST CONDITIONS	MIN	TYP	MAX	UNIT
V_{FB}	FB pin voltage when FB pin sink current is at (IFB - 50 μA)			5.6		V
ΔV_{FB}	FB pin voltage variation when FB pin sink current ranges from (IFB - 50 μA) to (IFB - 5 μA)			0.28		V
ΔV_{clamp}	FB pin voltage variation when FB pin sink current ranges from (IFB - 5 μA) to (IFB + 5 μA)			0.4		V
I_{FBclamp}	Maximum FB internal current source when FB is clamped			82		μA
$\Delta V_{\text{FBclamp}}$	FB pin voltage variation when FB pin sink current ranges from (IFB + 5 μA) to (IFB + IFB _{Clamp} - 5 μA)			0.25		V
$f_{-3\text{dB}}$	Feedback chain -3dB cut off frequency (2)		1			MHz
RESONANT CURRENT SENSE						
$V_{\text{ISNS_OCP1}}$	OCP1 threshold		3.9	4	4.1	V
$V_{\text{ISNS_OCP1_S}}$	OCP1 threshold during soft start		4.85	5	5.15	V
$V_{\text{ISNS_OCP2}}$	OCP2 threshold		0.57	0.6	0.63	V
$V_{\text{ISNS_OCP3}}$	OCP3 threshold		0.40	0.43	0.46	V
$t_{\text{ISNS_OCP2}}$	The time the average input current needs to stay above OCP2 threshold before OCP2 is triggered (1)			2		ms
$t_{\text{ISNS_OCP3}}$	The time the average input current needs to stay above OCP3 threshold before OCP3 is triggered (1)			50		ms
$V_{\text{ipolarityHyst}}$	Resonant current polarity detection hysteresis		16	30	44	mV
n_{OCP1}	Number of OCP1 cycles before OCP1 fault is tripped (1)			4		
RESONANT CAPACITOR VOLTAGE SENSE						
V_{CM}	Internal common mode voltage		2.90	3	3.14	V
I_{RAMP}	Frequency compensation ramp current source value		1.84	2	2.16	mA
I_{Mismatch}	Pull up and pull down ramp current source mismatch (3)		-1.25		1.25	%
GATE DRIVER						
V_{LOL}	LO output low voltage	$I_{\text{sink}} = 20\text{ mA}$	0.02	0.05	0.12	V
$V_{\text{RVCC}} - V_{\text{LOH}}$	LO output high voltage	$I_{\text{source}} = 20\text{ mA}$	0.10	0.18	0.3	V
$V_{\text{HOL}} - V_{\text{HS}}$	HO output low voltage	$I_{\text{sink}} = 20\text{ mA}$	0.02	0.05	0.12	V
$V_{\text{HB}} - V_{\text{HOH}}$	HO output high voltage	$I_{\text{source}} = 20\text{ mA}$	0.10	0.18	0.3	V
$V_{\text{HB-HSUVLOFall}}$	High side gate driver UVLO falling threshold		6.6	7.25	7.75	V
$V_{\text{HB-HSUVLOHys}}$	High side gate driver UVLO threshold hysteresis		0.78	0.9	1.05	V
$I_{\text{source_pk_HO}}$	HO peak source current (2)			-0.6		A
$I_{\text{source_pk_LO}}$	LO peak source current (2)			-0.6		A
$I_{\text{sink_pk_HO}}$	HO peak sink current (2)			1.2		A
$I_{\text{sink_pk_LO}}$	LO peak sink current (2)			1.2		A
BOOTSTRAP						

All voltages are with respect to GND, $-40^{\circ}\text{C} < T_J = T_A < 125^{\circ}\text{C}$, $V_{CC} = 15\text{ V}$, currents are positive into and negative out of the specified terminal, unless otherwise noted.

PARAMETER		TEST CONDITIONS	MIN	TYP	MAX	UNIT		
$I_{\text{BOOT_QUIESC}}^{\text{ENT}}$	(HB - HS) quiescent current	HB - HS = 12 V	42	62	80	μA		
$I_{\text{BOOT_LEAK}}$	HB to GND leakage current	$V_{\text{HB}} = 600\text{ V}$		0.40	5.40	μA		
$t_{\text{ChargeBoot}}$	Length of charge boot state		230	265	300	μs		
SOFT START AND BURST MODE								
I_{SSUp}	Current output from SS pin to charge up the soft start capacitor		26	36	45	μA		
R_{SSDown}	SS pin pull down resistance	ZCS or OCP1	300	370	450	Ω		
$t_{\text{SSInitVolPrgm}}$	SS initial voltage programming time ⁽¹⁾		720	776	830	μs		
R_{LL}	LL/SS voltage scaling resistor value		92	98	106	$\text{k}\Omega$		
N_{burst}	Minimum number of pulses in each burst packet (including burst soft on/off pulses)	For UCC256402, UCC256402A, UCC256403A, UCC256404A				16		
		For UCC256403, UCC256404, UCC256404B				40		
N_{softmax}	Maximum number of pulses for burst soft on/off					7		
K_{soft}	Minimal ratio of $V_{\text{comp}}/V_{\text{FBreplica}}$ during burst soft on/off					0.33		
$V_{\text{LLVolPrgm}}$	LL pin voltage during the burst mode exit threshold (BMT_{H}) programming					3.5	V	
BMT_{Hmin}	Minimal burst mode exit threshold					0.2	V	
BMT_{Lmin}	Minimal burst mode entry threshold					0.2	V	
BIAS WINDING								
V_{BWOVPos}	Output voltage OVP - Positive Threshold		3.86	4	4.12	V		
V_{BWOVNeg}	Output voltage OVP - Negative Threshold		-4.12	-4	-3.86	V		
n_{BWOV}	Number of BW OVP cycles before BW OVP fault is tripped ⁽¹⁾					5		
I_{BWPrgm}	BW pin sourcing current for $\text{BMT}_{\text{L}}/\text{BMT}_{\text{H}}$ programming		51	54	57	μA		
t_{BWPrgm}	$\text{BMT}_{\text{L}}/\text{BMT}_{\text{H}}$ programming time					2	ms	
$K_{\text{BMTL/BMTH1}}$	Ratio of $\text{BMT}_{\text{L}}/\text{BMT}_{\text{H}}$ Option 1					0.95		
$K_{\text{BMTL/BMTH2}}$	Ratio of $\text{BMT}_{\text{L}}/\text{BMT}_{\text{H}}$ Option 2					1		
$K_{\text{BMTL/BMTH3}}$	Ratio of $\text{BMT}_{\text{L}}/\text{BMT}_{\text{H}}$ Option 3					0.9		
$K_{\text{BMTL/BMTH4}}$	Ratio of $\text{BMT}_{\text{L}}/\text{BMT}_{\text{H}}$ Option 4					0.8		
$K_{\text{BMTL/BMTH5}}$	Ratio of $\text{BMT}_{\text{L}}/\text{BMT}_{\text{H}}$ Option 5					0.6		
$K_{\text{BMTL/BMTH6}}$	Ratio of $\text{BMT}_{\text{L}}/\text{BMT}_{\text{H}}$ Option 6					0.6		
$K_{\text{BMTL/BMTH7}}$	Ratio of $\text{BMT}_{\text{L}}/\text{BMT}_{\text{H}}$ Option 7 (Burst mode disable)					0.4		
R_{BWPrgm1}	BW pin equivalent resistance to choose $\text{BMT}_{\text{L}}/\text{BMT}_{\text{H}}$ ratio option 1 ⁽²⁾					24730	Ω	
R_{BWPrgm2}	BW pin equivalent resistance to choose $\text{BMT}_{\text{L}}/\text{BMT}_{\text{H}}$ ratio option 2 ⁽²⁾					17125	19976	Ω
R_{BWPrgm3}	BW pin equivalent resistance to choose $\text{BMT}_{\text{L}}/\text{BMT}_{\text{H}}$ ratio option 3 ⁽²⁾					12562	13624	Ω
R_{BWPrgm4}	BW pin equivalent resistance to choose $\text{BMT}_{\text{L}}/\text{BMT}_{\text{H}}$ ratio option 4 ⁽²⁾					9018	9813	Ω
R_{BWPrgm5}	BW pin equivalent resistance to choose $\text{BMT}_{\text{L}}/\text{BMT}_{\text{H}}$ ratio option 5 ⁽²⁾					6478	6849	Ω

All voltages are with respect to GND, $-40^{\circ}\text{C} < T_J = T_A < 125^{\circ}\text{C}$, $V_{CC} = 15\text{ V}$, currents are positive into and negative out of the specified terminal, unless otherwise noted.

PARAMETER		TEST CONDITIONS	MIN	TYP	MAX	UNIT
$R_{BWPrgm6}$	BW pin equivalent resistance to choose BMT_L/BMT_H ratio option 6 ⁽²⁾		4450		4732	Ω
$R_{BWPrgm7}$	BW pin equivalent resistance to choose BMT_L/BMT_H ratio option 7 (Burst mode disable) ⁽²⁾		2422		3038	Ω
ADAPTIVE DEADTIME						
dV_{HS}/dt	Detectable slew rate ⁽¹⁾		-0.1		-50	V/ns
FAULT RECOVERY						
$t_{PauseTimeOut}$	Paused timer ⁽¹⁾			1		s
THERMAL SHUTDOWN						
T_{J_r}	Thermal shutdown temperature ⁽¹⁾	Temperature rising	125	145		$^{\circ}\text{C}$
T_{J_H}	Thermal shutdown hysteresis ⁽¹⁾			10		$^{\circ}\text{C}$

(1) Not tested in production. Ensured by characterization

(2) Not tested in production. Ensured by design

(3) $I_{Mismatch}$ calculated as $[I_{PU} - (I_{PD} + I_{PU})/2] / [(I_{PD} + I_{PU})/2]$

6.6 Switching Characteristics

All voltages are with respect to GND, $-40^{\circ}\text{C} < T_J = T_A < 125^{\circ}\text{C}$, $V_{CC} = 15\text{ V}$, currents are positive into and negative out of the specified terminal, unless otherwise noted.

PARAMETER		TEST CONDITIONS	MIN	TYP	MAX	UNIT
$t_{r(LO)}$	Rise time	10% to 90%, 1 nF load		30	50	ns
$t_{f(LO)}$	Fall time	10% to 90%, 1 nF load		20	50	ns
$t_{r(HO)}$	Rise time	10% to 90%, 1 nF load		30	50	ns
$t_{f(HO)}$	Fall time	10% to 90%, 1 nF load		20	50	ns
$t_{DT(min)}$	Minimum dead time ⁽¹⁾			100		ns
$t_{DT(max)}$	Maximum dead time (dead time fault) ⁽¹⁾	ZCS event is not detected		1.1		μs
$t_{DT(max_ZCS)}$	Maximum dead time (dead time fault) ⁽¹⁾	ZCS event is detected		150		μs
$t_{ON(min)}$	Minimum gate on time ⁽¹⁾			250		ns
$t_{ON(max)}$	Maximum gate on time ⁽¹⁾			16		μs

(1) Not tested in production. Ensured by design

6.7 Typical Characteristics

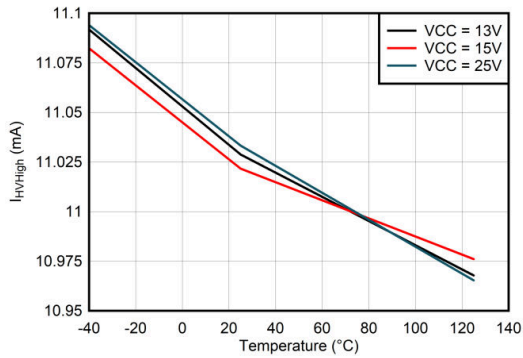

Figure 6-1. I_{HVHigh} vs Temperature

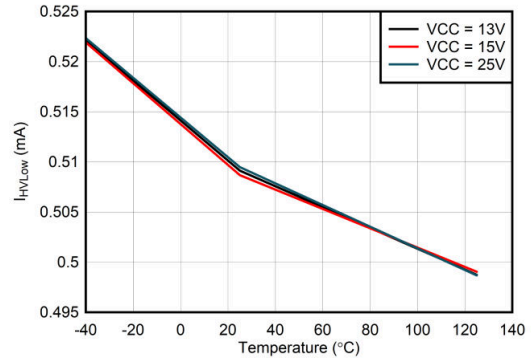

Figure 6-2. I_{HVLow} vs Temperature

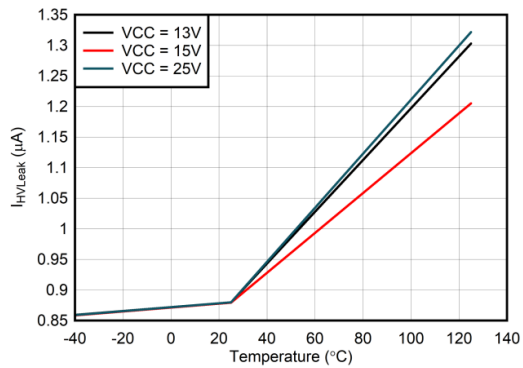

Figure 6-3. I_{HVLeak} vs Temperature

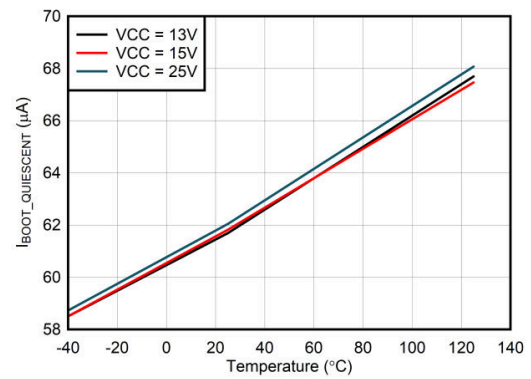

Figure 6-4. I_{BOOT_QUIESCENT} vs Temperature

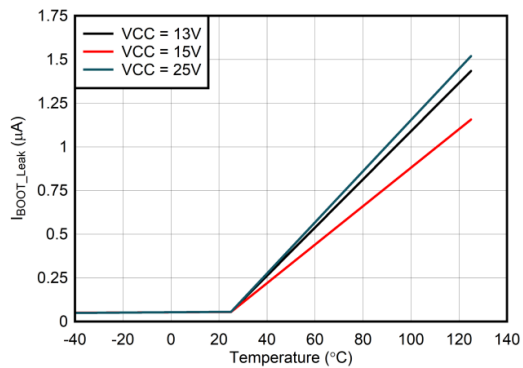

Figure 6-5. I_{BOOT_LEAK} vs Temperature

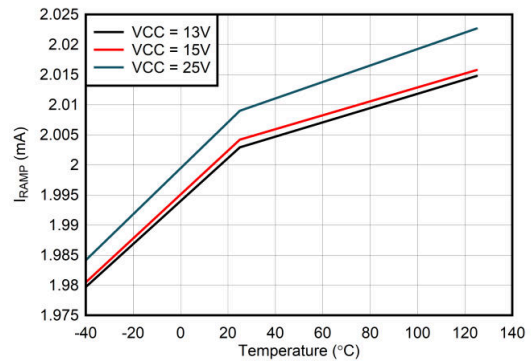

Figure 6-6. I_{RAMP} vs Temperature

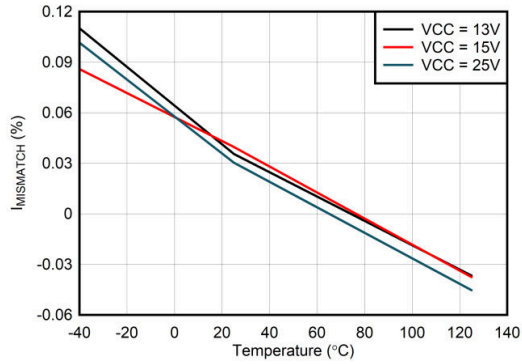

Figure 6-7. $I_{MISMATCH}$ vs Temperature

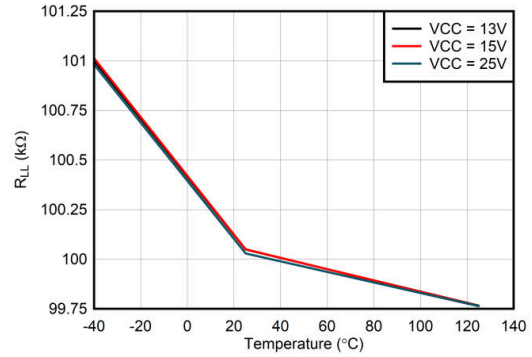

Figure 6-8. R_{LL} vs Temperature

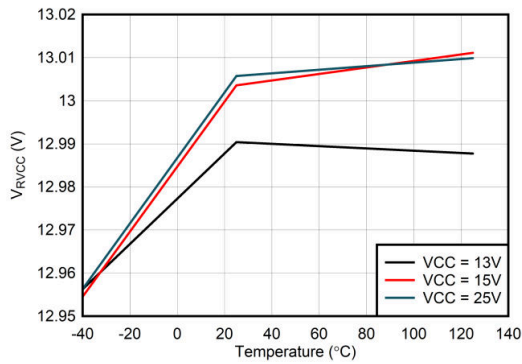

Figure 6-9. V_{RVCC} (no load) vs Temperature

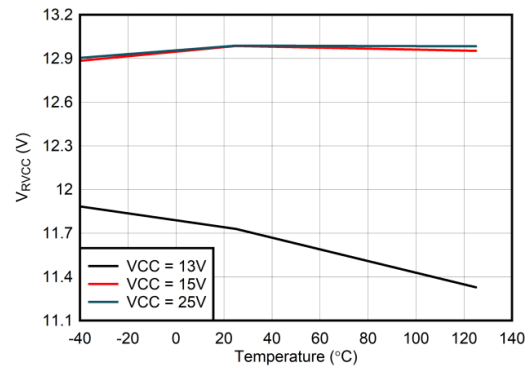

Figure 6-10. V_{RVCC} (100mA load) vs Temperature

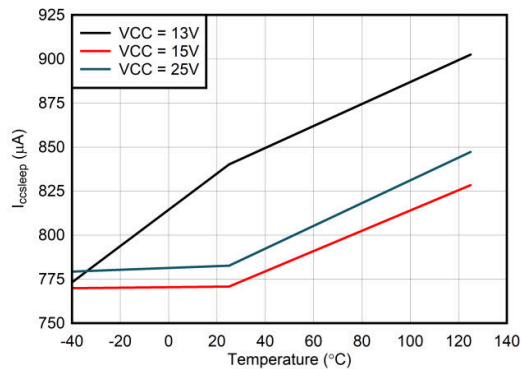

Figure 6-11. $I_{CCSLEEP}$ vs Temperature

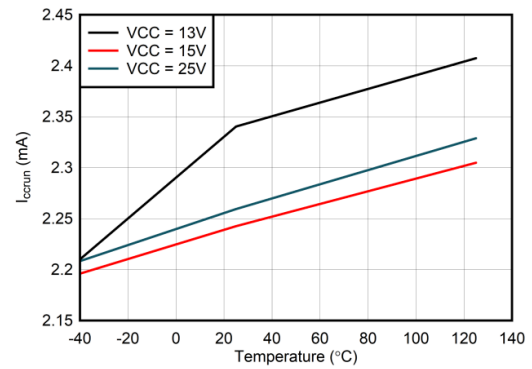

Figure 6-12. I_{CCRUN} vs Temperature

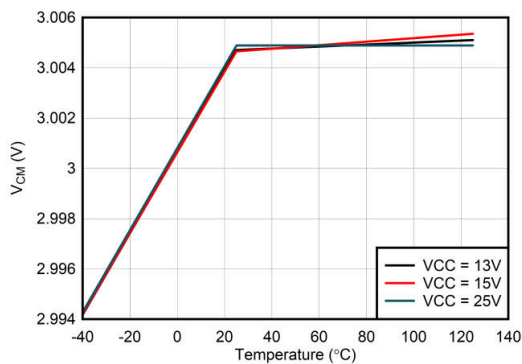

Figure 6-13. V_{CM} vs Temperature

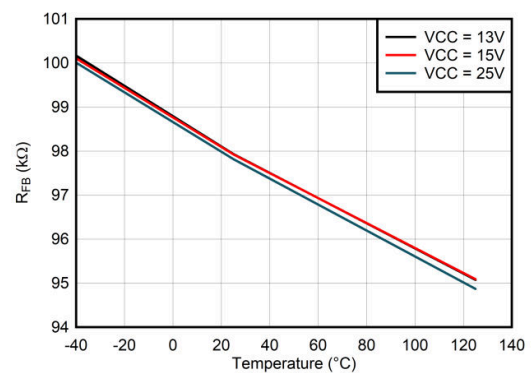

Figure 6-14. R_{FB} vs Temperature

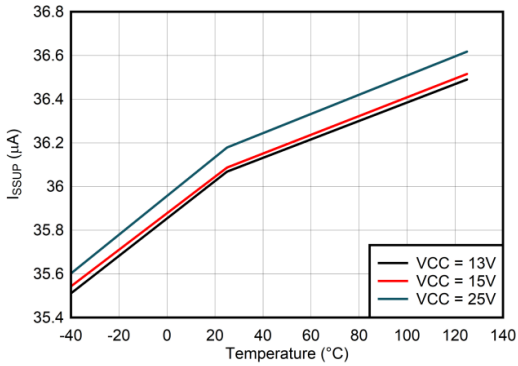

Figure 6-15. I_{SSUP} vs Temperature

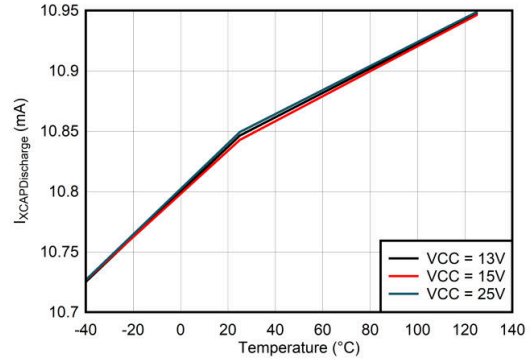

Figure 6-16. $I_{XCAPDischarge}$ vs Temperature

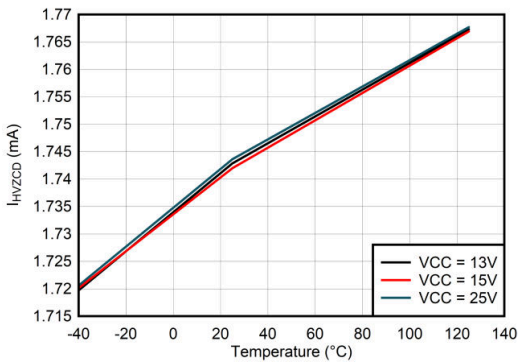

Figure 6-17. I_{HVZCD} vs Temperature

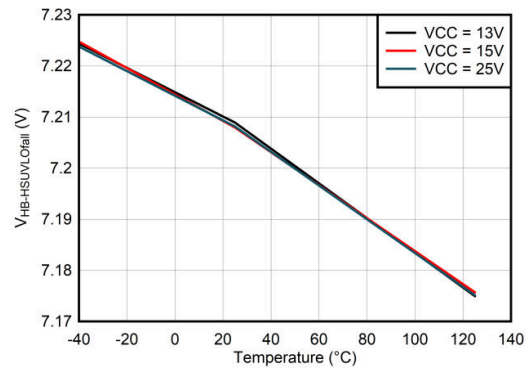

Figure 6-18. $V_{HB-HSUVLOFall}$ vs Temperature

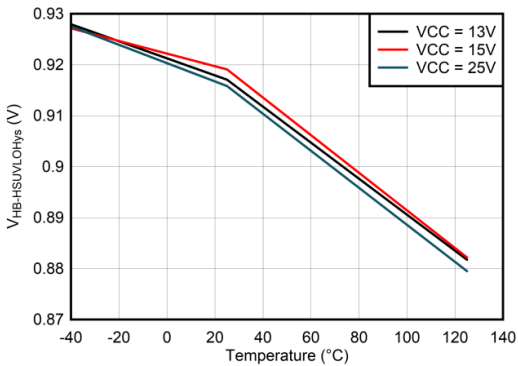

Figure 6-19. $V_{HB-HSUVLOHys}$ vs Temperature

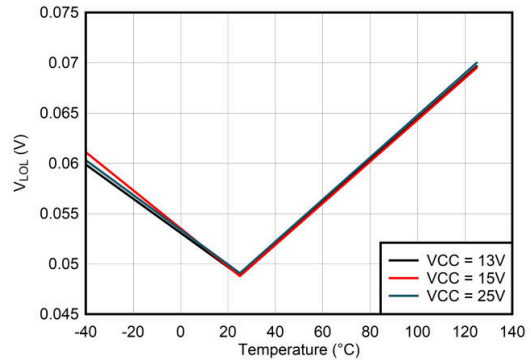

Figure 6-20. V_{LOL} vs Temperature

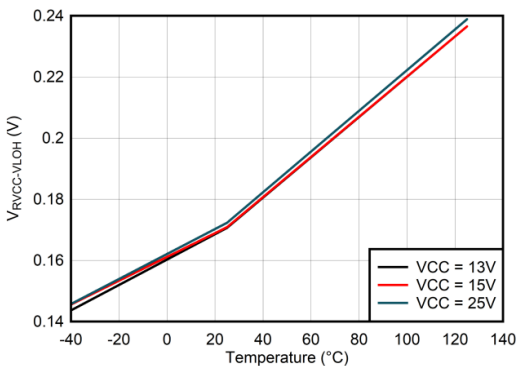

Figure 6-21. $V_{RVCC-VLOH}$ vs Temperature

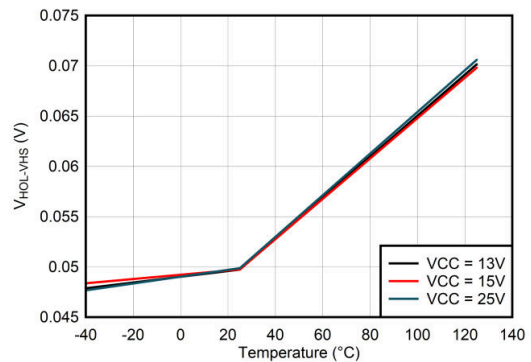

Figure 6-22. $V_{HOL-VHS}$ vs Temperature

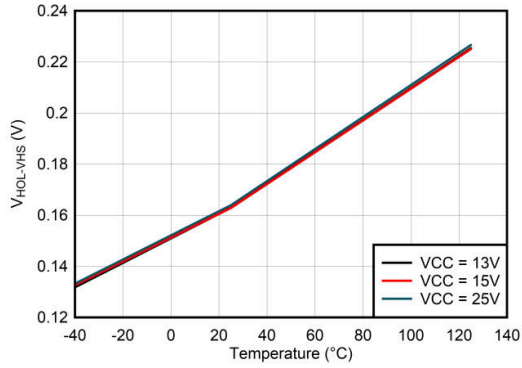

Figure 6-23. V_{HB} - V_{HOH} vs Temperature

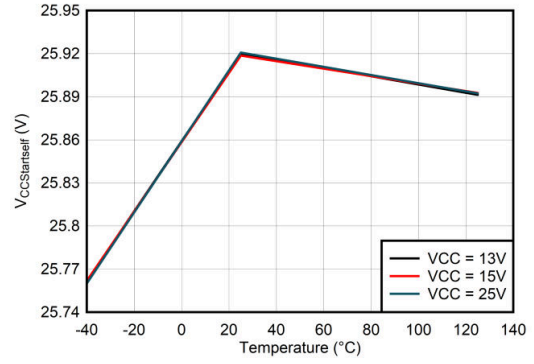

Figure 6-24. V_{CCstartself} vs Temperature

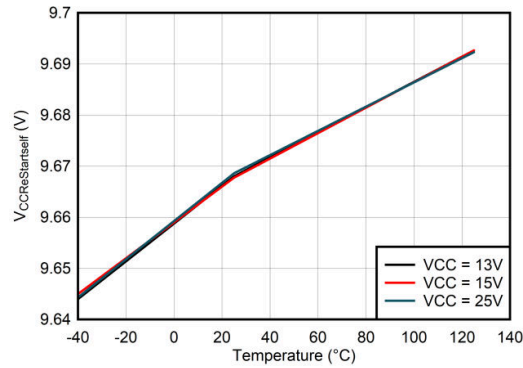

Figure 6-25. V_{CCRestartJfet} vs Temperature

7 Detailed Description

7.1 Overview

The UCC25640x is a fully featured LLC resonant controller for AC/DC power supplies. The high level of integration of UCC25640x enables significant reduction of component count and solution size without compromising functionality. UCC25640x achieves very low standby power and low audible noise standby operation using an optimized burst mode. The device's novel control scheme offers excellent transient performance.

Many consumer applications, including large screen televisions, AC-DC adapters, industrial power supplies, and LED drivers, employ PFC + LLC power supplies because they offer improved efficiency and small size, compared with a PFC + flyback topology. A disadvantage of the PFC + LLC power supply system is that it has poor light load efficiency and high no-load power consumption because the LLC stage requires a minimum amount of circulating current to maintain regulation. To meet light load efficiency and standby power consumption requirements, traditionally an auxiliary flyback converter is used. The auxiliary flyback converter runs continuously to allow the main PFC + LLC power system to be shut down when the system enters low power or standby mode. UCC25640x contains a number of novel features that enable it to offer excellent light load efficiency and low no-load power. This will allow power supply designers to create systems that meet the stringent no-load power target without needing an auxiliary flyback converter.

UCC25640x uses a novel control algorithm, Hybrid Hysteretic Control (HHC), to achieve regulation. In this control algorithm, the switching frequency is defined by the resonant capacitor voltage, which carries accurate input current information. This allows the controller to monitor and correct the input current directly. Compared with traditional Direct Frequency Control (DFC), HHC makes the system close to a first order system if the frequency control portion is small. This enables excellent load and line transient response.

UCC25640x adopts an advanced burst mode to meet the stringent requirements on standby power consumption and audible noise level. At low output power levels UCC25640x automatically transitions into light-load burst mode. In burst mode, UCC25640x repetitively delivers a burst packet with a fixed number of switching pulses and a shut-off period. The shut-off time period between burst packets is terminated by the secondary regulator loop based on the FB pin current. The LLC equivalent load current level during the burst on period is a programmable value. For each burst packet, the switching frequency slowly ramps down at the first few switching periods and ramps up at the last few switching periods, to slowly ramp up and ramp down the resonant current during burst operation. This burst soft-on and soft-off can effectively help to minimize the audible noise during burst mode operation. In addition, UCC25640x operates in a low power mode during burst mode with a very low quiescent current and biased optocoupler operation with low current.

UCC25640x monitors the half-bridge switch node to determine the required dead-time for the gate signals. In this way the dead-time is automatically adjusted to provide optimum efficiency and robust operation. UCC25640x includes a slew rate detector with improved sensitivity of the switch node voltage for adaptive dead-time that makes its operation inherently robust compared with alternative parts.

UCC25640x includes high and low-side drivers that can directly drive N-channel MOSFETs in an LLC power stage. This allows complete and fully featured power systems to be realized with minimum component count.

UCC256402 and UCC256404 includes a high-voltage startup JFET to initially charge the VCC capacitor to provide the energy needed to start the PFC and LLC power system. Once running, power for the PFC and LLC controllers is derived from a bias winding on the LLC transformer. UCC256404 also includes the active X-capacitor discharge feature to discharge the remaining voltage on the X-capacitor of the EMC filters after unplugging the AC input. UCC256403 does not include the high voltage startup and active X-capacitor discharge features. It requires an auxiliary supply to power the VCC.

UCC25640x includes robust algorithms for avoiding the zero-current switching (ZCS) operation region. When ZCS operation is detected, UCC25640x overrides the feedback signal and ramps up the switching frequency until non-capacitive operation is restored, after which the switching frequency is ramped back down at a rate determined by the soft-start capacitor until control has been handed back to the voltage control loop.

Additional protection features of UCC25640x include three-level over current protection (OCP), output over voltage protection (OVP), input voltage under-voltage protection (UVP), gate driver under-voltage lock-out (UVLO) protection, and over temperature protection (OTP).

The key features of UCC25640x can be summarized as follows:

- Hybrid Hysteretic Control helps achieve best-in-class load and line transient response
- Optimized light load burst mode enables less than 150-mW standby power designs
- Burst soft-on and soft-off enables ultra-quiet standby operation
- Robust adaptive dead time control
- Integrated high-voltage gate driver
- Integrated high-voltage startup for UCC256402 and UCC256404
- Active X-capacitor discharge for UCC256404
- Improved capacitive region operation prevention scheme
- Comprehensive protection feature set

7.2 Functional Block Diagram

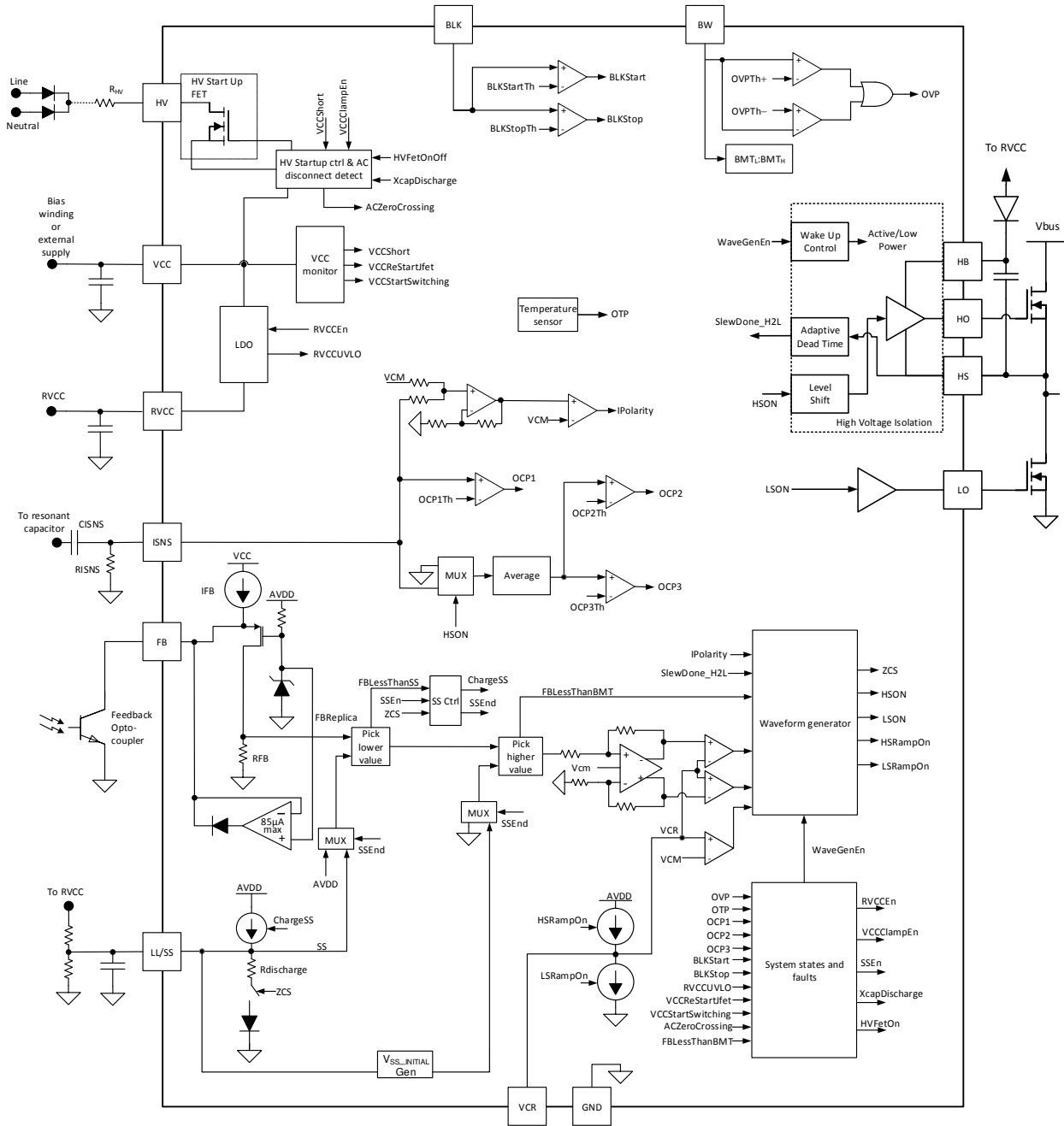

7.3 Feature Description

7.3.1 Hybrid Hysteretic Control

UCC25640x uses a novel control scheme, Hybrid Hysteretic Control (HHC), to achieve best-in-class line and load transient performance. The control method makes the compensator easier to design. The control method also makes light load management easier and more efficient. Improved line transient enables lower bulk capacitor and output capacitor values, reducing system cost.

HHC is a control method which combines traditional frequency control and charge control. It is a charge control with an added frequency compensation ramp. Compared with traditional frequency control, it changes the power stage transfer function from a second order system to a first order system, so that it makes the compensation network design easier. The control effort is directly related to input current, so superior line and load transients can be achieved. Compared with charge control, Hybrid Hysteretic Control avoids instability by adding in a frequency compensation ramp. The frequency compensation ensures system stability, and makes the output impedance lower as well. Lower output impedance makes the transient performance better than charge control. The frequency compensation also makes the implementation of burst mode soft-on and soft-off much easier, as changing the control effort can directly impact the switching frequency. For burst mode soft-on and soft-off, the converter switching frequency self-adjusts to achieve a reduced resonant current.

In summary, HHC solves the following problems:

- Help LLC converters achieve superior load transient and line transient
- Changes the small-signal transfer function to a first order system to easily achieve very high bandwidth
- Inherently stable via frequency compensation
- Makes burst mode control easier to optimize light load efficiency
- Makes the implementation of burst mode soft-on and soft-off much easier, to achieve lower audible noise

Figure 7-1 shows the HHC implementation in UCC25640x: a capacitor divider (C1 and C2) and two well matched controlled current sources. The resonant capacitor voltage is divided down by the capacitor divider formed by C1 and C2. The current sources are controlled by the gate drive signals. When the high-side switch is on, the upper current source injects a constant current into the capacitor divider; when the low-side switch is on, the lower current source pulls the same amount of constant current out of the capacitor divider. The two current sources add a triangular compensation ramp to the VCR node. The current sources are supplied by a reference voltage AVDD. AVDD needs to be equal to or larger than twice the common mode voltage V_{CM} . The divided resonant capacitor voltage and the compensation ramp voltage are then added together to get the VCR node voltage. If the frequency compensation ramp dominates, the VCR node voltage will look like a triangular waveform, and the control will be similar to direct frequency control. If the resonant capacitor voltage dominates, the shape of the VCR node voltage will look like the actual resonant capacitor voltage, and the control will be similar to charge control. This is why the control method is called “hybrid” and the compensation ramp is called frequency compensation.

This set up has an inherent negative feedback to keep the high-side and low-side on-time balanced, and also to keep the common mode voltage at the VCR node at V_{CM} .

There are two input signals needed for the new control scheme: VCR and V_{COMP} . VCR is the sum of the scaled down version of the resonant capacitor voltage and the frequency compensation ramp. V_{COMP} is the voltage loop compensator output. The waveform below shows how the high-side and low-side switches are controlled based on VCR and V_{COMP} . The common mode voltage of VCR is V_{CM} .

Based on V_{COMP} and V_{CM} (3 V), two thresholds: V_{TH} and V_{TL} are created.

$$V_{TH} = V_{CM} + \frac{V_{comp}}{2} \quad (1)$$

$$V_{TL} = V_{CM} - \frac{V_{comp}}{2} \quad (2)$$

The VCR voltage is compared with the two thresholds. When $V_{CR} > V_{TH}$, the high-side switch is turned off; when $V_{CR} < V_{TL}$, low-side switch is turned off. HO and LO turn on edges are controlled by the adaptive dead time circuit.

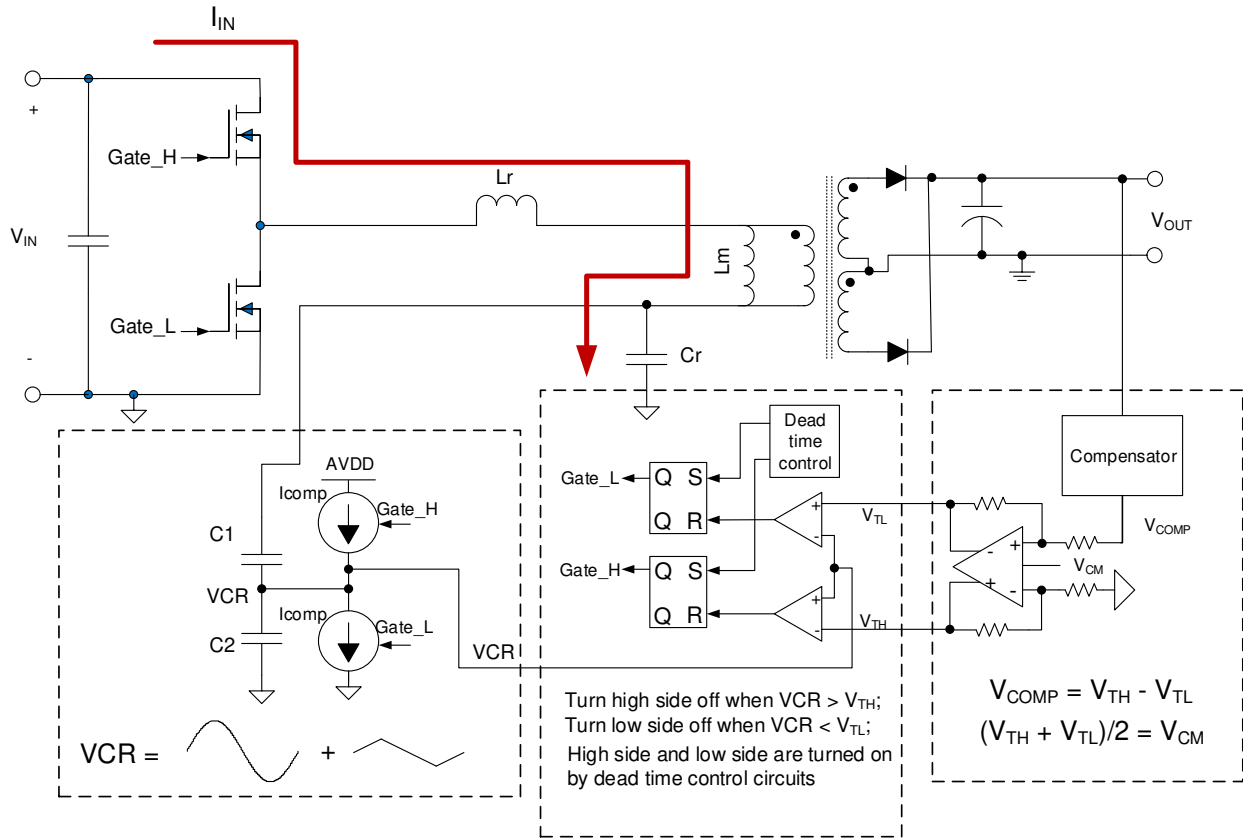

Figure 7-1. UCC25640x HHC Implementation

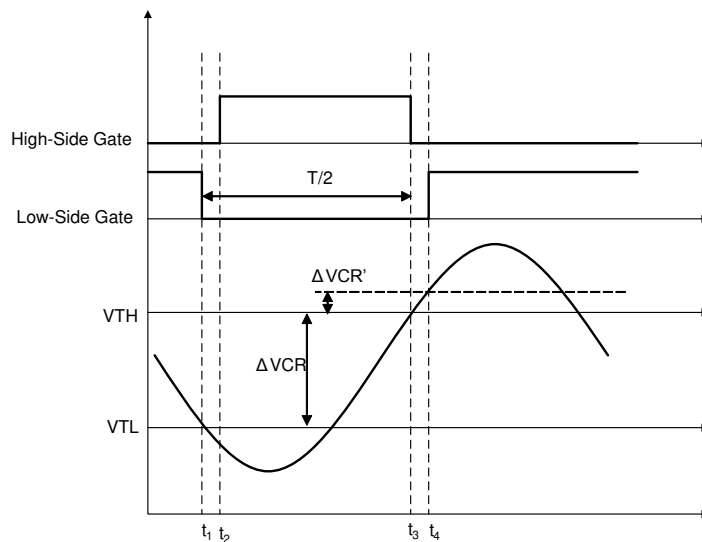

Figure 7-2. HHC Gate On/Off Control Principle

7.3.2 Regulated 13-V Supply

RVCC pin is the regulated 13-V supply. This regulated rail is used to supply the PFC and LLC as a bias. RVCC has under voltage lock out (UVLO) function. During normal operation, if the RVCC voltage is less than

$R_{VCC_{UVLO}}$ threshold, the system will enter FAULT state. Details about the FAULT handling will be discussed in the [Section 7.3.9](#) section.

7.3.3 Feedback Chain

Control of the output voltage is provided by a voltage regulator circuit located on the secondary side of the isolation barrier. The demand signal from the secondary regulator circuit is transferred across the isolation barrier using an optocoupler and is fed into the FB pin on UCC25640x. This section discusses the whole feedback chain. [Figure 7-3](#) shows the block diagram of the FB chain, and [Figure 7-4](#) shows the typical timing diagram with a normal soft start followed by a ZCS event, and load step into burst mode, and then exiting burst mode.

The feedback chain has the following functions:

- Optocoupler feedback signal input and bias
- FB voltage clamp
- Soft start function selection by a "pick lower value" block
- Burst mode selection by a "pick higher value" block
- Convert single ended feedback demand into two thresholds V_{TH} and V_{TL} ; and VCR comparison with the thresholds and the common mode voltage V_{CM}

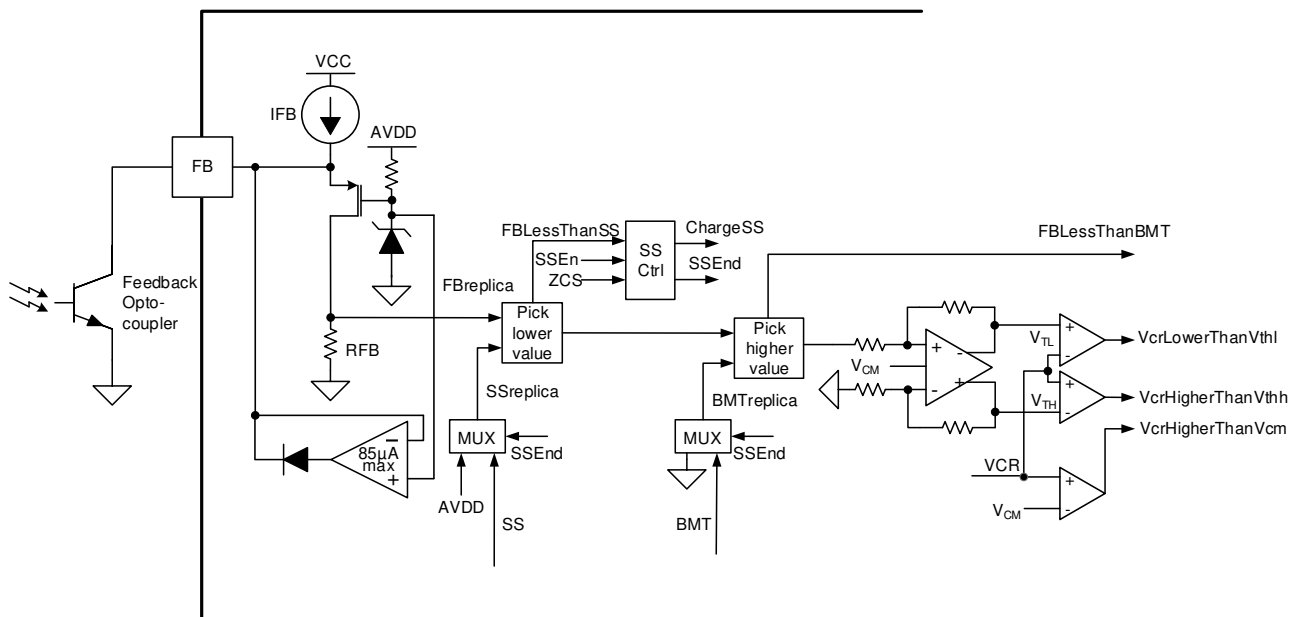

Figure 7-3. Feedback Chain Block Diagram

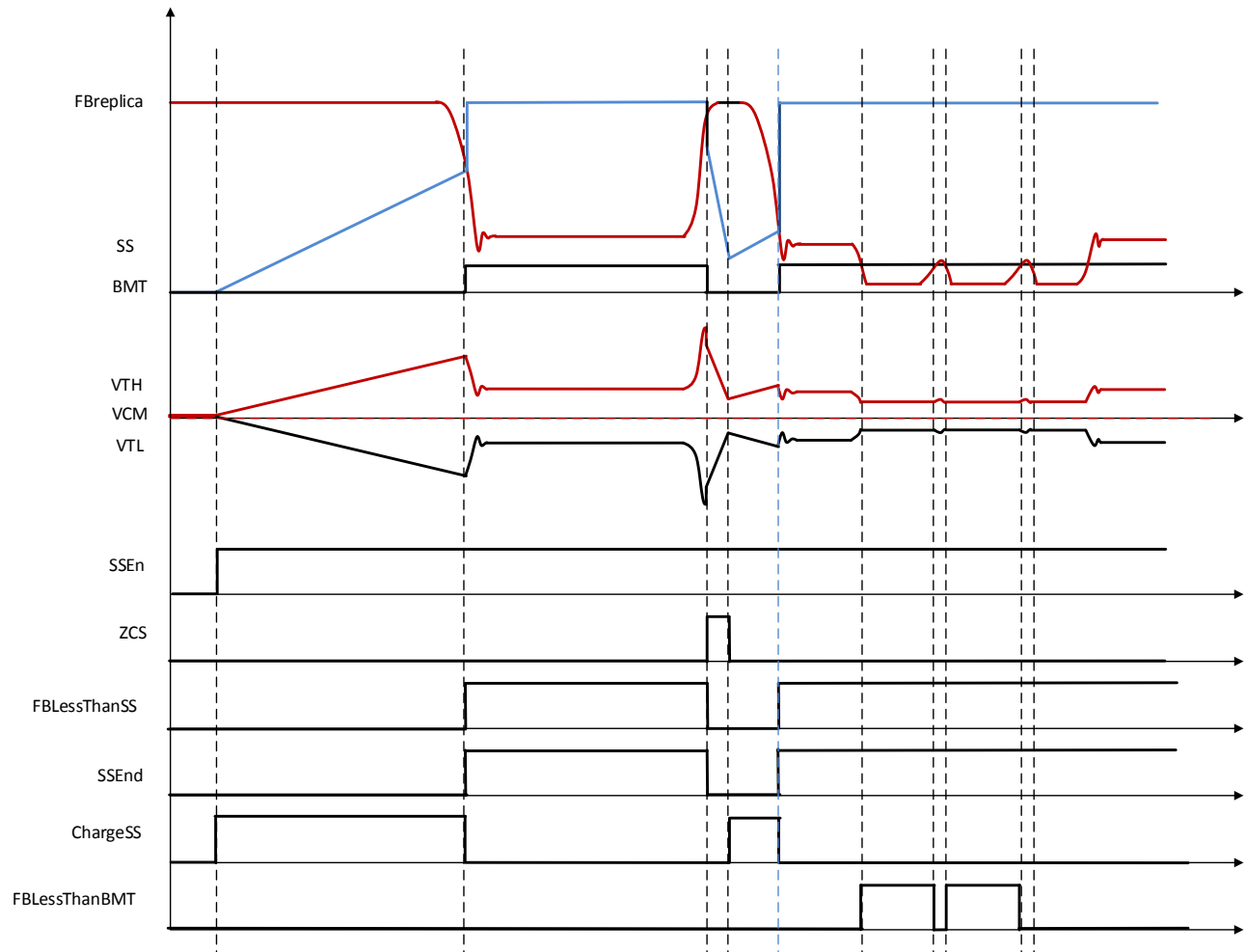

Figure 7-4. Feedback Chain Timing Diagram

7.3.3.1 Optocoupler Feedback Signal Input and Bias

The secondary regulator circuit and optocoupler feedback circuit all add directly to the standby power consumed by the system. To achieve very low standby power it is necessary to drive the optocoupler in a low current mode.

As shown in Figure 7-3, a constant current source I_{FB} is generated from VCC voltage and connected to FB pin. A resistor R_{FB} is also connected to this current source with a PMOS in series. During normal operation, the PMOS is always on, so that the FB pin voltage will be equal to the zener diode reference voltage plus the voltage drop on the PMOS source to gate.

$$I_{FB} = I_{opto} + I_{RFB} \quad (3)$$

From this equation, when I_{opto} increases, I_{RFB} will decrease, making $FB_{replica}$ decrease. In this way, the control effort is inverted. A conventional way to bias the optocoupler is using a pull up resistor on the collector of the optocoupler output. To reduce the power consumption, the pull up resistor needs to be big, which will limit the loop bandwidth. For the bias current method used in UCC25640x, the FB pin voltage is maintained constant so that the parasitic capacitor of the optocoupler will not introduce an extra pole to the system, and subsequently limit the loop bandwidth.

7.3.3.2 FB Pin Voltage Clamp

As shown in the Section 7.3.3.1 section, the $FB_{replica}$ decreases while I_{opto} increases. When I_{opto} reaches the value of I_{FB} , the FB pin voltage starts to drop because there is no current flow through the PMOS. FB pin pulled

low will impact the system transient response, due to the extra delay introduced by charging the parasitic capacitor of the optocoupler to pull up the FB pin voltage. A FB pin voltage clamp circuit is used to prevent this scenario. When FB pin voltage drops below the FB pin clamp voltage threshold, an extra current source is turned on to clamp the FB voltage. The clamp strength is $I_{FBclamp}$. The FB pin clamp circuit improves the system transient performance from light load to heavy load.

7.3.3.3 "Pick Lower Value" Block and Soft Start Multiplexer

This part of the circuit consists of 3 elements:

- A pick lower block
- A MUX which selects AVDD or SS signal as the second input to the pick lower block
- An SS control block which handles the charge and discharge of the SS capacitor in the case of a ZCS fault

The pick lower block has two inputs. The first input is FBreplica. The second input is selected between AVDD and LL/SS pin voltage. The output of the block is the lower of the two inputs.

The MUX selects between SS and AVDD. The selection is based on SSEnd (soft start end) signal, which is an output of the SS Ctrl block. SSEnd is high when SS is higher than FBreplica, and the soft start process has been initiated by the state machine, and there is no ZCS condition. Switching to AVDD after soft start has ended helps make sure that during non-soft start or non-ZCS fault condition, FBreplica signal is always sent through the pick lower block. It also releases the LL/SS pin to perform the light load threshold programming.

The SS control block handles the charge and discharge of the SS capacitor in the case of a ZCS fault. It resets the SSEnd signal when ZCS happens, so the effect of pulling down on LL/SS pin to increase the switching frequency can pass through the pick lower block.

7.3.3.4 Pick Higher Block and Burst Mode Multiplexer

The output of the pick lower block goes into a pick higher block, which selects the higher of the pick lower block output and the burst mode threshold setting.

The burst mode multiplexer selects between burst mode threshold (BMT) and ground. During soft start, the multiplexer selects ground. The startup process is open loop and controlled by the soft start ramp. Burst mode is not enabled during soft start phase.

After soft start, the higher of the two inputs are sent to the differential amplifier. The output of the block is FBLessThanBMT. This output is sent to the waveform generator state machine to control burst mode and system external shut down.

7.3.3.5 VCR Comparators

The output of the pick higher block is sent to a differential amplifier to convert the signal into two thresholds symmetrical to V_{CM} . The difference between the two thresholds V_{TH} and V_{TL} equals the input amplitude. The VCR pin voltage is then compared with V_{TH} , V_{TL} , and V_{CM} . The results are sent to the waveform generator.

7.3.4 Resonant Capacitor Voltage Sensing

The resonant capacitor voltage sense pin senses the resonant capacitor voltage through a capacitor divider. Inside the device, two well matched, controlled current sources are connected to the VCR pin to generate the frequency compensation ramp. The on/off control signals of the two current sources come from the waveform generator block.

During waveform generator IDLE state or before startup, the VCR node is clamped to V_{CM} . This action will help reduce the startup peak current, and help the VCR voltage to settle down quickly during burst mode.

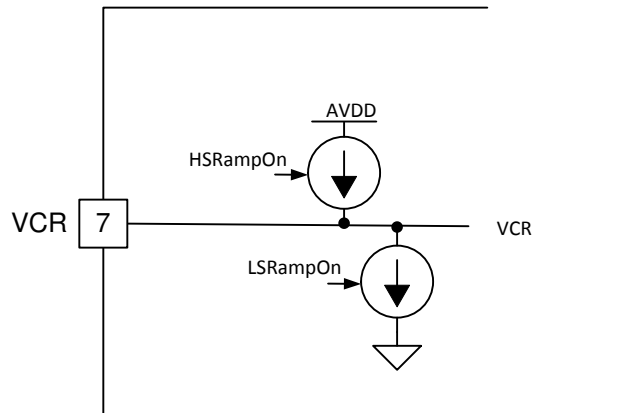

Figure 7-5. VCR Block Diagram

The ramp current on/off sequence is shown in Figure 7-6. The ramp current is on all the time. It changes direction at the falling edge of the high-side on or low-side on signal.

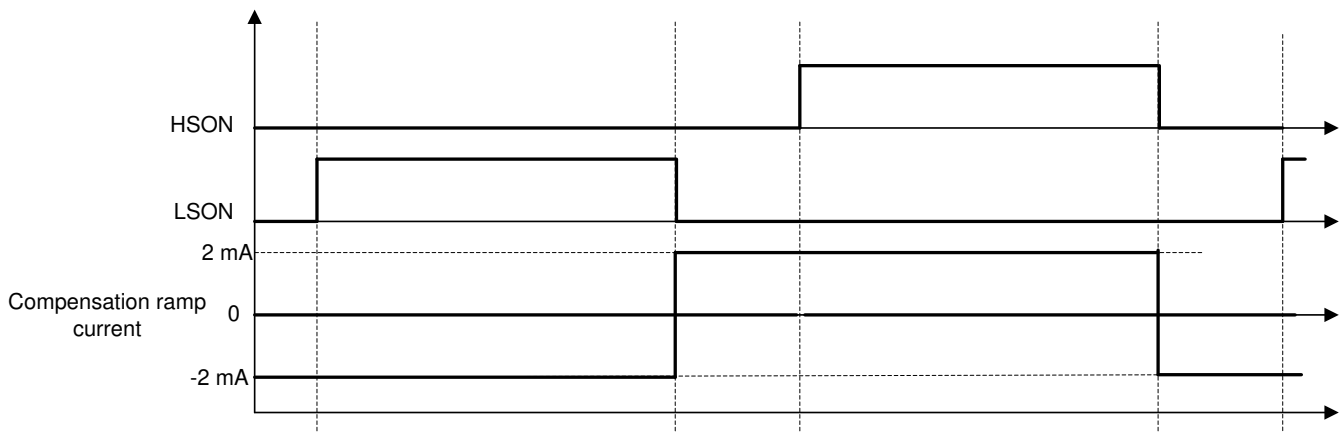

Figure 7-6. VCR Compensation Ramp Current On/Off

On the VCR pin, a capacitor divider is used to combine the resonant capacitor waveform and the compensation ramp waveform. Adjusting the size of the external capacitors can change the contribution of charge control and direct frequency control. Assuming the divided down version of the resonant capacitor voltage by the capacitor divider is V_{div} , the compensation ramp current resultant voltage on the VCR pin is V_{ramp} . If V_{div} is much larger than V_{ramp} , the control method is similar to charge control, in which the control effort is proportional to the input charge of one switching cycle. If V_{ramp} is much larger than V_{div} , the control method is similar to direct frequency control, in which the control effort is proportional to the switching frequency. The most optimal transient response can be achieved by adjusting the ratio between V_{div} and V_{ramp} .

7.3.5 Resonant Current Sensing

The ISNS pin is connected to the resonant capacitor using a high voltage capacitor. The capacitor CISNS and the resistor RISNS form a differentiator. The resonant capacitor voltage is differentiated to get the resonant

current. The differentiated signal is AC and goes both positive and negative. In order to sense the zero crossing, the signal is level shifted using an op amp adder. The IPolarity comparator detects the direction of the resonant current. IPolarity is checked at LSON and HSON falling edges for ZCS protection, with more details described in [Section 7.3.9.1](#) section. The digital state machine implements a blanking time on IPolarity. The IPolarity edges during the first 400 ns of dead time are ignored considering the noise on ISNS pin introduced by the switching node transition.

OCP2 and OCP3 thresholds are based on average input current. To get the average input current, the differentiator output is multiplexed with the high-side switch on signal HSON. When HSON is on, the MUX output is the differentiator output; when HSON is off, the MUX output is 0. The MUX output is then averaged using a low pass filter. The output of the filter is the sensed average input current. Note that the MUX needs to pass through both positive and negative voltages. OCP2 and OCP3 faults have a 2 ms and 50 ms timer respectively. Only when the OCP2/OCP3 comparators output high for continuous 2 ms or 50 ms, will the faults be activated.

OCP1 threshold is set on the peak resonant current. The voltage on the ISNS pin gets compared to OCP1 threshold OCP1Th directly. The peak resonant current is checked once per cycle on the positive half cycle. OCP1 fault is only activated when there are 4 consecutive cycles of OCP1 event detected. During start up, the OCP1 comparator output of the first 15 cycles are ignored.

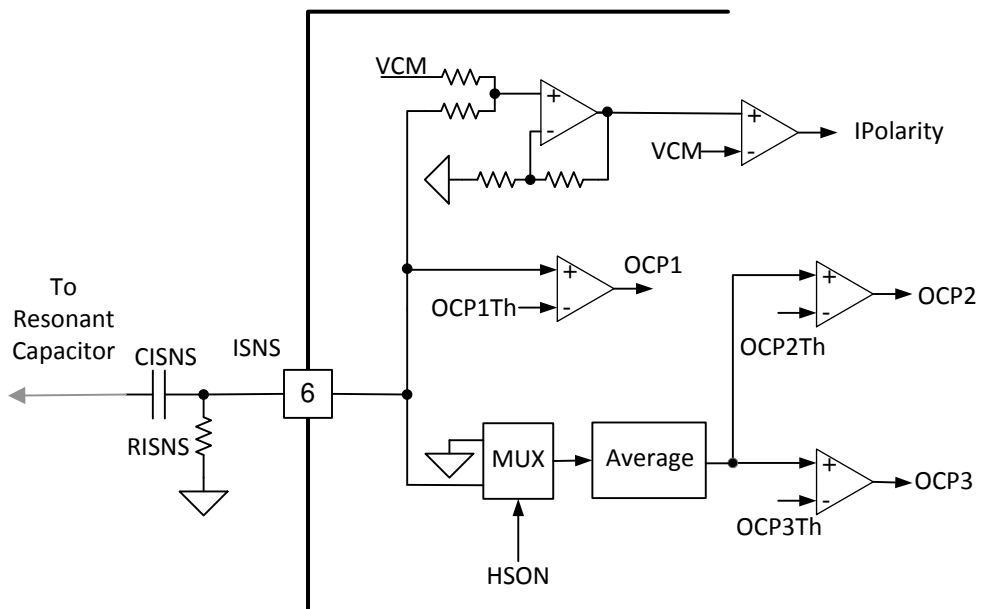

Figure 7-7. ISNS Block Diagram

7.3.6 Bulk Voltage Sensing

The BLK pin is used to sense the LLC DC input voltage (bulk voltage) level. The comparators on BLK pin have the following two thresholds:

- Bulk voltage level when LLC starts switching – $V_{BLKStart}$
- Bulk voltage level when LLC stops switching – $V_{BLKStop}$

A resistor divider is connected to the pin to achieve the desired system input range. A fault is triggered if BLK pin voltage drops lower than $V_{BLKStop}$ during operation. The detailed action of Input Under Voltage Protection is described in [Section 7.3.9.4](#) section.

Figure 7-8 shows the block diagram of the BLK pin.

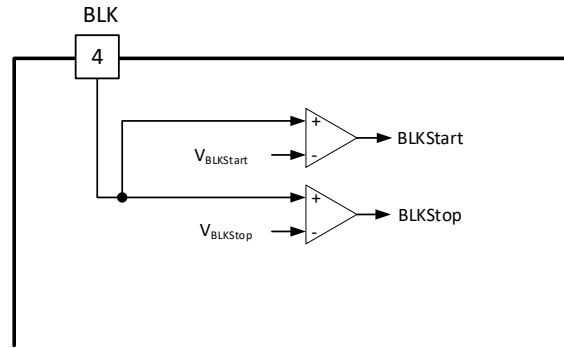

Figure 7-8. BLK Pin Block Diagram

BLK voltage is also used to monitor the input over voltage fault for some device versions as listed in [Section Device Comparison Table](#). There are two thresholds:

- Bulk voltage level when BLK over voltage protection (OVP) rising threshold - $V_{BLKOVPRise}$
- Bulk voltage level when BLK over voltage protection (OVP) falling threshold - $V_{BLKOVPFall}$

When BLK voltage is higher than $V_{BLKOVPRise}$, OVP is triggered; OVP gets cleared when BLK voltage falls below $V_{BLKOVPFall}$.

7.3.7 Output Voltage Sensing

The output voltage is sensed through the bias winding (BW) voltage sense pin. With one terminal of the bias winding connected to primary side ground, the bias winding voltage at the other terminal represents the output voltage when the secondary side rectifier diode conducts. A resistor divider is typically used to connect from the bias winding terminal to the BW pin. The BW voltage is compared with a positive and a negative threshold to generate an output OVP fault. During startup, BW pin is multiplexed for burst mode threshold programming. The details are introduced in the [Section 7.4.3.1](#) section. The block diagram of the bias winding voltage sense block is shown below.

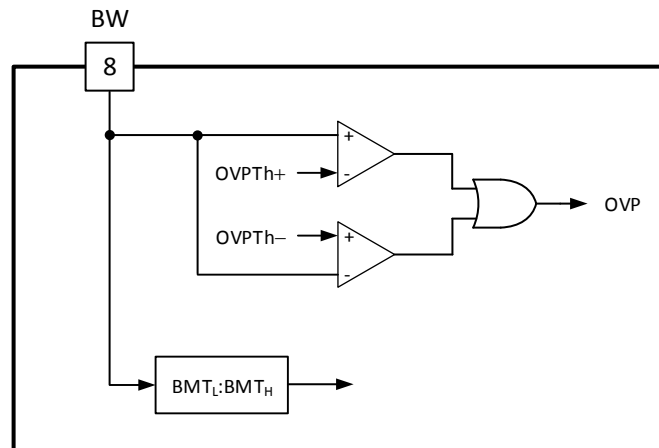

Figure 7-9. Bias Winding Sensing Block Diagram

If the OVP event is high for 5 consecutive switching cycles, the system will enter FAULT state. The actions during an OVP fault are described in the [Section 7.3.9.3](#) section.

7.3.8 High Voltage Gate Driver

LO is the low-side gate driver output. The gate driver is supplied by the 13-V RVCC rail.

The high-side driver module consists of three physical device pins. HB and HS form the positive and negative bias rail, respectively, of the high-side driver, and HO connects to the gate of the upper half-bridge MOSFET.

During periods when the lower half-bridge MOSFET is conducting, HS is shorted to GND via the conducting lower MOSFET. At this time power for the high-side driver is obtained from RVCC via the high voltage diode DBOOT, and capacitor CBOOT is charged to RVCC minus the forward drop on the diode.

During periods when the upper half-bridge MOSFET is conducting, HS is connected to the LLC input voltage rail. At this time the HV diode is reverse biased and the high-side driver is powered by the charge stored in CBOOT.

Both the high-side and low-side gate drivers have under voltage lock out (UVLO) protection. The low-side gate driver UVLO is implemented on RVCC; the high-side gate driver UVLO is implemented on (HB - HS) voltage.

When operating at light load, UCC25640x enters burst mode. During the burst off period, the gate driver enters low power mode to reduce power consumption.

The block diagram of the gate driver is shown in [Figure 7-10](#).

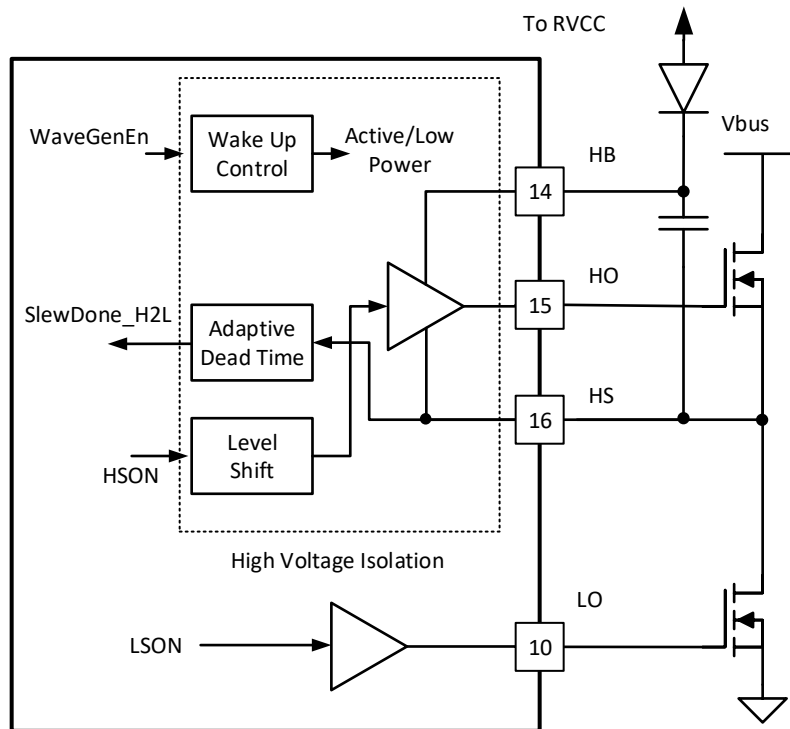

Figure 7-10. Gate Driver Block Diagram

7.3.8.1 Adaptive Dead Time Control

The Dead Time describes the time interval between an outgoing LLC MOSFET turning off and the incoming LLC MOSFET turning on. Dead time control is critical for LLC operation. A certain amount of dead time is required to prevent shoot through. During the dead time, the HS node slews from one input rail to the other due to the inductive resonant current. In order to achieve zero voltage switching (ZVS) turn on, the dead time needs to be long enough for the resonant current to fully charge or discharge the HS node. But after the body diode starts conducting, the MOSFET should be turned on quickly. Too long of a turn on delay can result in reverse resonant current and lead to the loss of ZVS. Also, the voltage drop on the body diode is higher than that on the MOSFET channel. Optimized dead time can help to minimize the power loss.

The resonant current flowing through the HS node during the dead time depends on the LLC resonant tank design and varies by operating frequency and output/input voltage ratio. Therefore, the optimized dead time varies widely with LLC operating conditions. UCC25640x includes an adaptive dead time control to automatically find the optimized dead time across the entire operating range. It detects the change of slew rate of the HS node voltage. During a switching transition, the slew rate rises up first and then drops back to zero. A slew rate detector is used to detect the moment when the slew rate drops below a pre-defined threshold. A slew done event is only detected when the slew rate during dead time crosses the threshold and then drops back below the threshold. If the slew rate is lower than the threshold (i.e. minimal detectable slew rate) during the whole dead time period, no slew done will be detected. This is to prevent the mis-detection due to noise on the HS node voltage. If slew done is not detected, maximum dead time is used.

Because of the natural symmetric operation of LLC, only the dead time between high-side MOSFET turn off and low-side MOSFET turn on is determined by the slew rate detector. This dead time is copied and then applied to the dead time between low-side MOSFET turn off and high-side MOSFET turn on.

7.3.9 Protections

7.3.9.1 ZCS Region Prevention

The capacitive region is an LLC operating region in which the voltage gain increases when the switching frequency increases. It is also called the ZCS region. Capacitive mode operation should be avoided for two reasons:

- The feedback loop becomes positive feedback in the capacitive region
- The MOSFET may be damaged because of body diode reverse recovery

The capacitive region detection is done by checking the resonant current polarity at HSON or LSON falling edge. If the resonant current is positive at LSON falling edge, or negative at HSON falling edge, the ZCS signal in the waveform generator is turned high. The ZCS signal stays high until ZCS is cleared at the next HSON or LSON falling edge.

If ZCS is detected, the next gate will be turned on at the next IPolarity flip event when the resonant current becomes inductive again. The IPolarity flip indicates that the capacitive operation cycle has already passed. The resonant current reverses direction and begins to discharge the switch node. In this stage, the body diode is no longer conducting and it is allowed to turn on the next gate. If there is a slew done event detected, it suggests that the opposite body diode must not be conducting and the next gate will be turned on as well. If neither the IPolarity flip event or slew done event is detected, the next gate will be turned on by the maximum dead time timer expiration. During a ZCS event, the maximum dead time is changed to 150 μ s.

ZCS typically happens when the LLC operates at heavy load condition and the switching frequency is too low. Therefore, when ZCS is detected, the LL/SS pin is pulled low through a diode to ground and the system enters a "ZCS soft start" process. The switching frequency is forced to ramp up in order for the system to recover from ZCS. The details of the "ZCS soft start" are described in the [Section 7.4.3.1](#) section. As the ZCS detection relies on the resonant current polarity detection, if LLC operates at very light load condition, the magnitude of the resonant current can be very small and there may be chances that the resonant current polarity detection can be distorted by the switching noise. In order to prevent the nuisance ZCS detection at light load condition, ZCS is disabled at light load condition by utilizing the burst mode control. The details are described in the [Section 7.4.3](#) section.

Below is the flow chart of the capacitive region prevention algorithm and the timing diagram of a ZCS event:

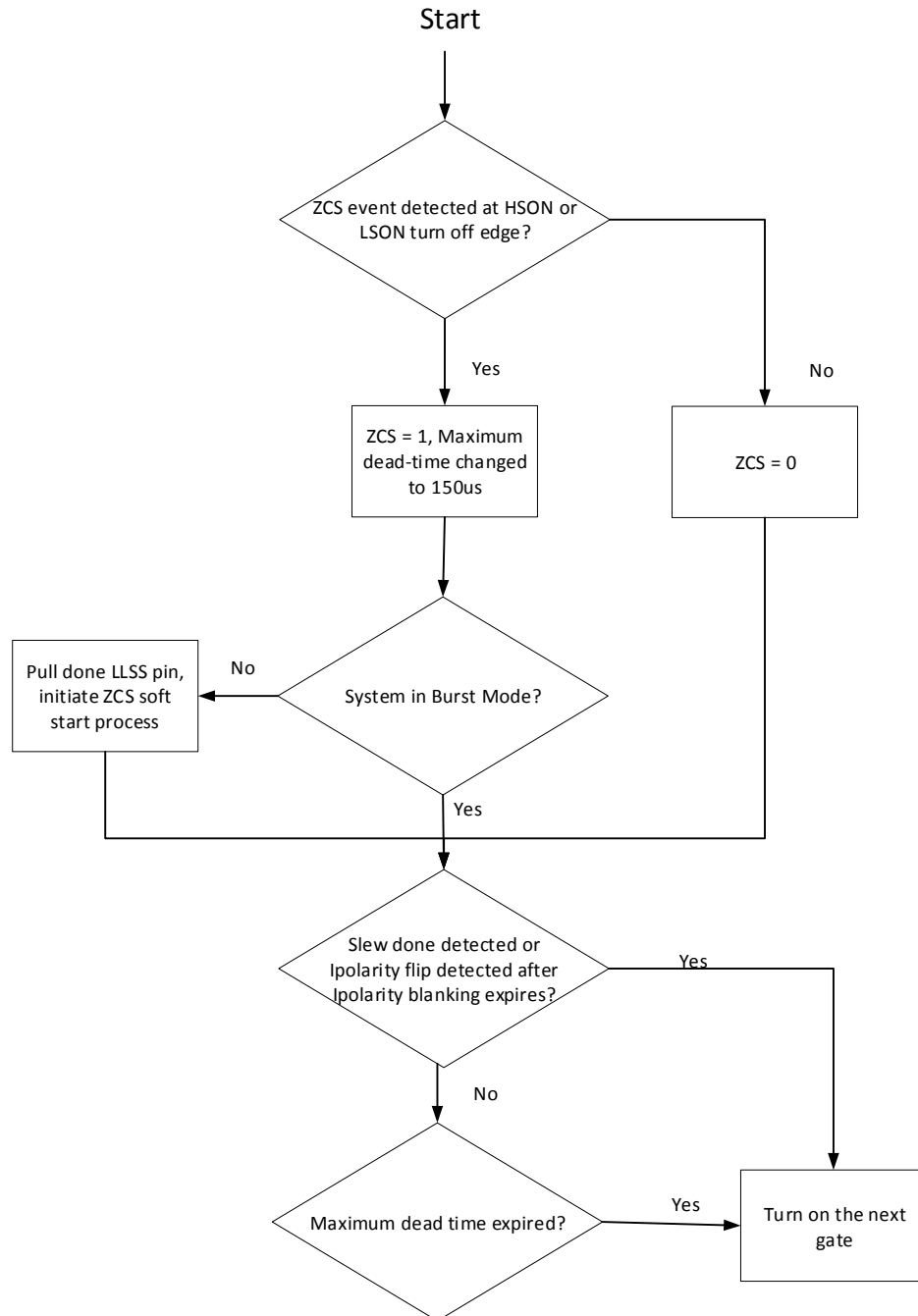

Figure 7-11. ZCS Prevention Algorithm Flow Chart

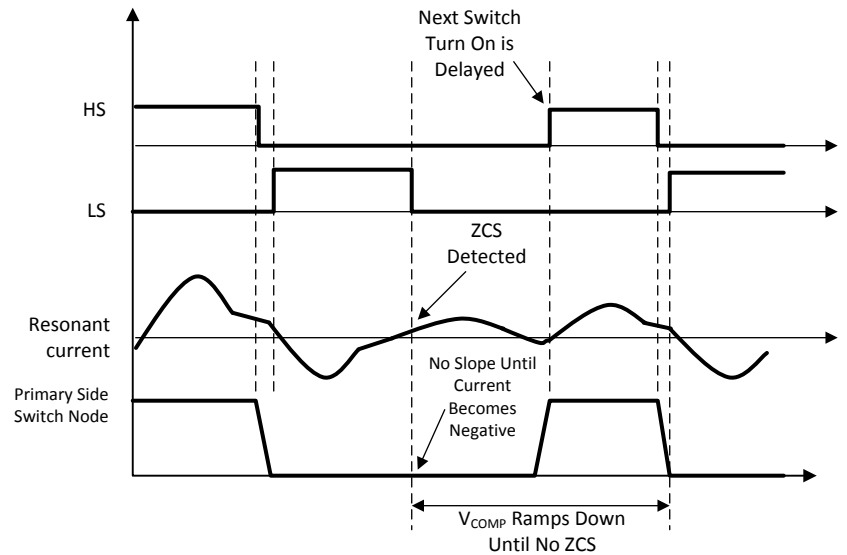

Figure 7-12. Timing Diagram of a ZCS Event

7.3.9.2 Over Current Protection (OCP)

There are three levels of OCP:

1. OCP1: peak current protection (highest threshold)
 - a. Fault action: If ISNS is higher than OCP1 threshold for 4 consecutive switching cycles, the switching will stop. The system enters FAULT state, and waits for 1 s and then re-enters the startup state.
2. OCP2: average input current protection (high threshold)
 - a. Fault action: If sensed ISNS average value is above the threshold for 2 ms, the switching will stop. The system enters FAULT state, and waits for 1 s and then re-enters the startup state.
3. OCP3: average input current protection (low threshold)
 - a. Fault action: If sensed ISNS average value is above the threshold for 50 ms, the switching will stop. The system enters FAULT state, and waits for 1 s and then re-enters the startup state.

The circuit block diagram has been discussed in the [Section 7.3.5](#) section.

7.3.9.3 Bias Winding Over Voltage Protection (BWOVP)

This is typically used for output over voltage protection when the transformer has a bias winding. The output over voltage trip point can be set by configuring the voltage divider on the BW pin. When the BW OVP comparator is high for 5 consecutive switching cycles, the switching will stop. The system enters fault state, and waits for 1 s and then re-enters the startup state.

7.3.9.4 Input Under Voltage Protection (VINUVP)

This is the input under voltage protection. The trip point can be set by configuring the voltage divider on the BLK pin. If the BLK voltage drops below BLKStop, switching will stop immediately. The system enters FAULT state, and waits for 1 s and then re-enters the startup state.

7.3.9.5 Input Over Voltage Protection (VINOVP)

This is the input over voltage protection. This feature only exists in some device versions. If the BLK voltage rises above $V_{BLKOVPRise}$, switching will stop immediately. The system enters FAULT state, and waits for 1s and then re-enters the startup state if BLK voltage falls below $V_{BLKOVPRise}$.

7.3.9.6 Boot UVLO

This is the high-side gate driver UVLO. When (HB – HS) voltage is less than the threshold, the high-side gate output will be shut down. The system does not enter FAULT state.

7.3.9.7 RVCC UVLO

This is the regulated 13-V UVLO. When RVCC voltage is less than the threshold, both the high-side gate output and the low-side gate output will be turned off immediately. The system enters FAULT state, and waits for 1 s and then re-enters the startup state.

7.3.9.8 Over Temperature Protection (OTP)

This is the device over temperature protection. When OTP threshold is exceeded, the switching will stop. The system enters FAULT state, and waits for 1 s and then re-enters the startup state if the temperature is back below the OTP threshold.

7.4 Device Functional Modes

7.4.1 High Voltage Start-Up

UCC256402 and UCC256404 uses a self bias start up scheme, thus eliminating the need for a separate auxiliary supply. When AC power is first plugged in, the PFC and LLC are both off. The internal JFET on the HV pin will be enabled and will start to deliver current from a source connected from the HV pin to the VCC capacitor. The charge current is small when VCC pin voltage is below $V_{CCShort}$, and then becomes larger when VCC pin voltage is above $V_{CCShort}$. Once the VCC pin voltage exceeds its $V_{CCStartSwitching}$ threshold, the current source will be turned off and RVCC will be enabled to turn on the PFC. When the PFC output voltage reaches a certain level, the LLC is turned on. When the LLC is operating and the output voltage is established, the bias winding will supply current for both the PFC and the LLC controller devices.

UCC256403 does not include a high voltage start-up feature. It requires an external auxiliary supply to power on the IC. The HV pin needs to be grounded when using the UCC256403.

7.4.2 X-Capacitor Discharge

X-capacitors used in EMC filters on the AC side of the diode bridge rectifier must have a method to allow them to discharge down to a reasonable voltage within a specific amount of time. This is to ensure that voltage does not remain present on the pins of the AC plug indefinitely after it is physically removed from the AC power.

Typically, discharge resistors are provided in parallel with the X-capacitors to provide this discharge path, but these resistors then lead to fixed standing power loss as long as the power supply is connected to AC power, and can be significant in the context of achieving very low standby power.

For every 100 nF of capacitance, a maximum bleed resistor of 10 M Ω must be added in parallel. For a typical 60-W to 100-W power supply with a typical capacitance of 330 nF, this requires 3 M Ω of discharge resistance. At nominal high line 230 V, these resistors dissipate 17.63 mW of standing power loss. Thus it is necessary to find alternative ways to discharge the X-capacitors using switched discharge paths in order to avoid the static standing loss.

There are several standards for X-capacitor discharge. IEC60950 and IEC60065 requires that the discharge time constant is less than 1s. IEC62368 requires that after 2 seconds of AC unplug, the remaining voltage on the x-capacitor is less than 60 V (for 300 nF or more capacitance). UCC25640x uses an active discharge scheme to support the fast discharge of up to 5- μ F X-capacitance, for device variants that has X-capacitor discharge.

To meet the requirements of the standards, AC disconnect events must be detected. UCC25640x detects AC disconnect by monitoring the AC zero crossings through the HV pin. When AC is present, there will be two AC zero crossings in one line cycle. When AC is disconnected, there will be no zero crossings for an extended period of time. [Figure 7-13](#) shows the rectified AC waveform. In the figure, the AC is disconnected at the peak of the last half AC cycle. In reality, it can be disconnected anywhere within a switching cycle.

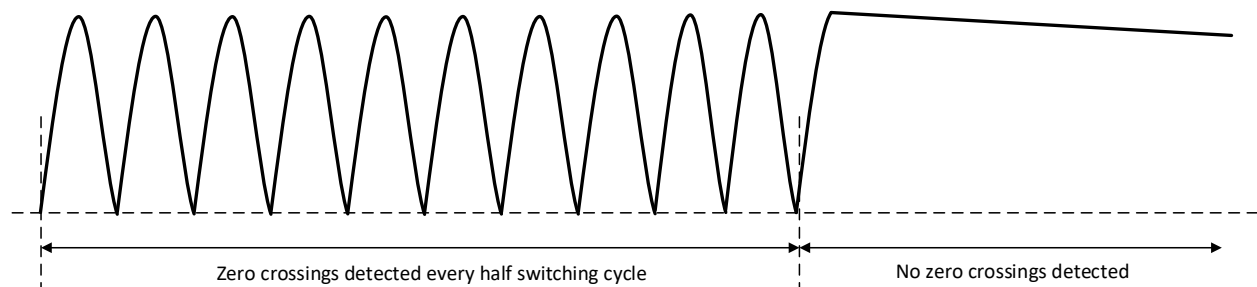

Figure 7-13. AC Disconnect Waveform

To detect the zero crossings reliably as well as save power consumption, a staircase test current is generated every 700 ms. When there are 4 zero crossings missing in a row at the highest test current setting, AC disconnect is confirmed and the $I_{XCapDischarge}$ current source is enabled. The waveform below shows the staircase current waveform:

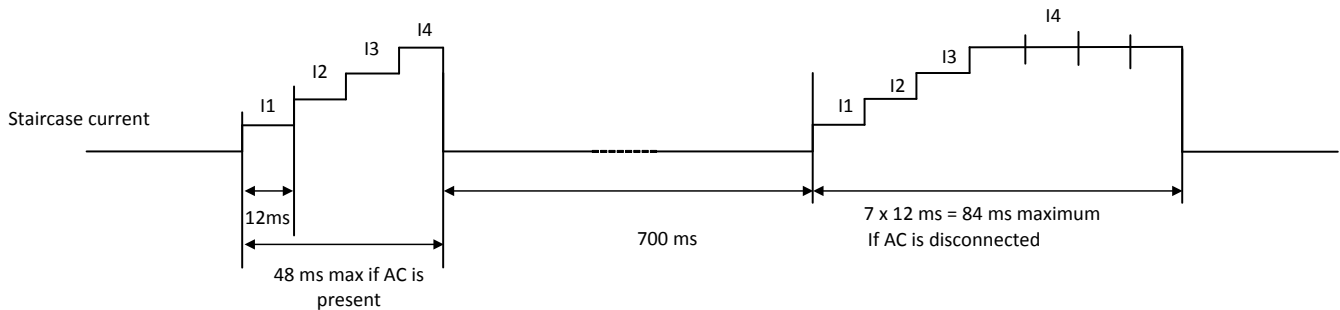

Figure 7-14. Staircase Test Current for X-Capacitor Discharge

The test current is required for reliable AC zero crossing sensing. In short, this is because the leakage current in the AC bridge rectifier diodes will affect the zero crossing detection at very light load. The added test current on the HV pin will overcome the leakage current and make sure that AC zero crossing is detected on the HV pin. If one zero crossing is detected during any test current stage, it means that AC is not disconnected. The test current will shut off immediately and the system goes to the 700-ms no test current stage.

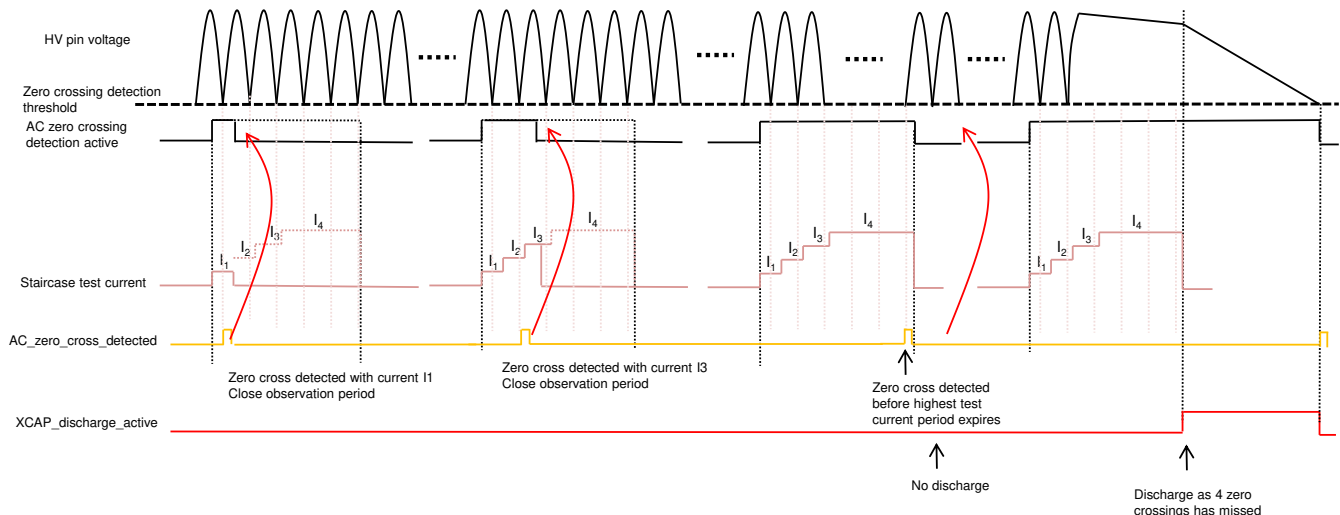

Figure 7-15. Different Staircase Current Waveforms

Figure 7-15 shows different staircase current waveforms. The last waveform shows the AC disconnect is detected and X-capacitor discharge current is enabled. The X-capacitor discharge current is enabled for 350 ms. AC zero crossing function is available in all operation modes and available all the time. Figure 7-16 shows the flow chart of AC zero crossing detection and X-capacitor discharge. The zero crossing test starts 12 ms after HV startup is completed. The discharge current $I_{XCapDischarge}$ is created by turning on the JFET and enabling a current source from JFET source to GND. During a fault restart process, HV startup is higher priority, so that the JFET is connected to VCC. A zero crossing test current will be sent out 12 ms after HV startup is completed, regardless of whether the detection idle timer has expired.

In some of the device variants, the X-capacitor discharge feature is disabled.

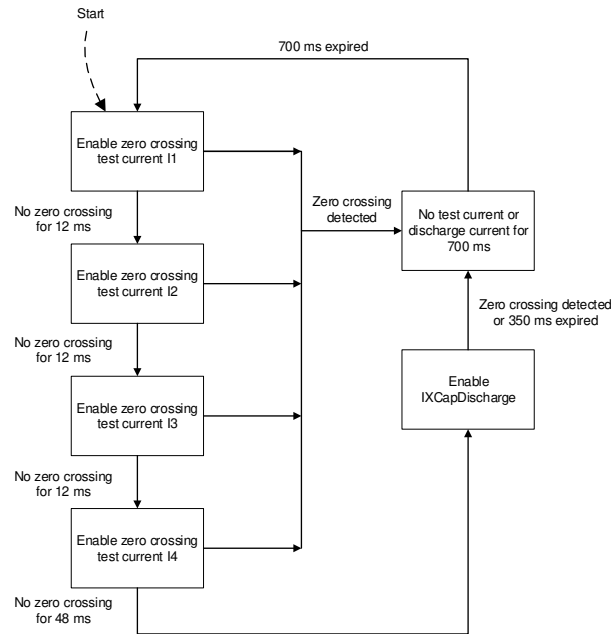

Figure 7-16. AC ZCD and X-Capacitor Discharge Flow Chart

7.4.3 Burst Mode Control

The efficiency of an LLC converter power stage drops rapidly with falling output power. To maintain reasonable light load efficiency it is necessary to operate the LLC converter in burst mode. In this mode the LLC converter operates at relatively high power for a short burst period and then switching is stopped for a time period. During the burst period excess charge is transferred to and stored in the output capacitor. During the burst off period this stored charge is used to supply the load current. The burst mode operation is critical to meet strict standby power consumption requirements. But a challenge with burst mode operation is the audible noise performance. Due to the need to stop switching for certain time, there will be a pattern of switching pulses with frequencies that fall within the audible frequency range from 20 Hz to 20 kHz. Some device variants of UCC25640x includes a burst mode with soft on and soft off periods at the first few and last few switching pulses, minimizing the audible noise during standby operation.

Figure 7-17 describes the timing diagram of the burst mode operation. Two burst mode thresholds are used (BMT_H for burst mode exit and BMT_L for burst mode entry). The details of how to program these two thresholds are described in Section 7.4.3.1 section. The FBreplica from the FB chain is compared with the two thresholds, and determines the burst mode operation.

- At t_1 , FBreplica is below BMT_L . The system enters burst mode and stops switching immediately. During the burst off period, UCC25640x disables some internal blocks to save power consumption.
- At t_2 , FBreplica is above BMT_H . The system starts to switch again, and this period is referred to as the burst on period. During burst on period, the control effort V_{comp} sent to the VCR comparator is the higher value of FBreplica and BMT_L . For the first switching pattern after the system enters burst mode, there is no burst soft on.
- At t_3 , FBreplica falls below BMT_L again. Switching will not stop until it reaches the predefined number (N_{burst}) of a burst packet. The V_{comp} still selects the higher value of FBreplica and BMT_L . For the last 7 switching cycles, soft off will be applied (only 3 soft on/off steps are shown in Figure 7-17 for conceptual introduction). The V_{comp} is a fraction of the higher value between FBreplica and BMT_L . The number of fractions for different switching cycles are described in Table 7-1. For burst soft off, it starts from step 7 and ramps down. After it reaches step 1, soft off steps are completed and the system enters burst off period. This helps to achieve slow ramping down of the LLC transformer current. For burst soft on, it reverses the direction by starting from step 1 and ends at step 7. If FBreplica becomes greater than BMT_L before the soft off steps are completed,

- the burst soft off will end immediately and the system transitions to burst soft on. In this condition, the soft on step starts from the step where soft off ends at, to ensure a smooth transition between soft off and soft on.
- At t_4 , FBreplica is greater than BMT_L . The system enters burst on period, and since this is not the first burst on period, there is soft on period at the first 7 switching cycles. The fraction of V_{comp} to the higher value of FBreplica and BMT_L is also described in Table 7-1. After burst soft on steps are completed, V_{comp} uses the higher value of FBreplica and BMT_L until it reaches burst soft off periods.
 - At t_5 , FBreplica is greater than BMT_L again after another burst off period. This time the difference is that FBreplica is greater than BMT_H at t_6 , when the burst soft on steps are not completed yet. The burst soft on will get terminated immediately, so that V_{comp} can follow the FBreplica. This is to ensure a quick system response during a load transient from burst mode operation to out-of-burst mode operation.

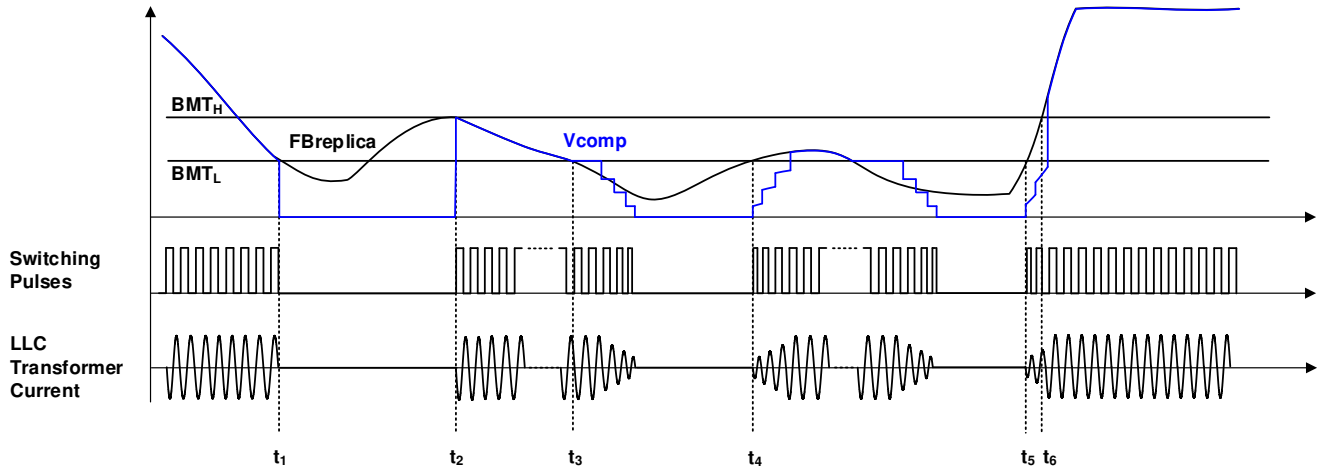

Figure 7-17. Burst Mode Switching Pattern

Table 7-1. Burst Mode Soft On and Soft Off V_{comp} Control

Burst Soft On and Soft Off Step	Fraction used for Reduced V_{comp} During Soft On
1	1/3
2	9/21
3	11/21
4	13/21
5	15/21
6	17/21
7	19/21

The HHC control makes the implementation of the burst soft on and soft off very straight forward. Due to the frequency control portion in HHC, changing the V_{comp} can directly impact the LLC switching frequency to control the resonant current magnitude within switching cycles. Also the last pulse of each burst on period is turned off when the VCR node voltage equals the common mode voltage VCM. In HHC control, this is approximately equivalent to resonant capacitor voltage equal to $V_{IN}/2$. This operation keeps the resonant capacitor voltage to approximate $V_{IN}/2$ for each burst off period, thus enabling the burst pattern to settle as soon as possible during the burst on period.

As described in Section 7.3.9.1, in order to avoid nuisance ZCS detection at light load condition, ZCS is disabled at light load condition. This is achieved by using the BMT_H threshold. When FBreplica is below BMT_H , indicating a light load operating condition, ZCS detection is disabled. When FBreplica is above BMT_H , ZCS detection will resume.

Some device variants disables the burst soft on and soft off feature, for applications that have less concern about audible noise, but want smaller output ripple during burst mode. A smaller burst packet size is also used.

The timing diagram of the burst mode operation for when burst soft on and soft off is disabled is described in [Figure 7-18](#).

- At t_1 , FBreplca is below BMT_L . The system enters burst mode and stops switching immediately.
- At t_2 , FBreplca is above BMT_H . The system starts to switch again, and enters burst on period. The control effort V_{comp} sent to the VCR comparator is the higher value of FBreplca and BMT_L .
- At t_3 , FBreplca falls below BMT_L again. Switching will not stop until it reaches the predefined number (N_{burst}) of a burst packet. If switching reaches the N_{burst} before FBreplca falls below BMT_L again, system will continue to deliver burst packet until FBreplca is below BMT_L .
- At t_4 , FBreplca is greater than BMT_L . The system enters burst on period without soft on. So the control effort V_{comp} is the higher value of FBreplca and BMT_L .
- At t_5 , FBreplca is greater than BMT_L again after another burst off period. The control effort V_{comp} follows FBreplca. At t_6 , FBreplca becomes above BMT_H , V_{comp} still follows FBreplca. If FBreplca remains above BMT_H more than N_{burst} switching cycles, system exits burst mode.

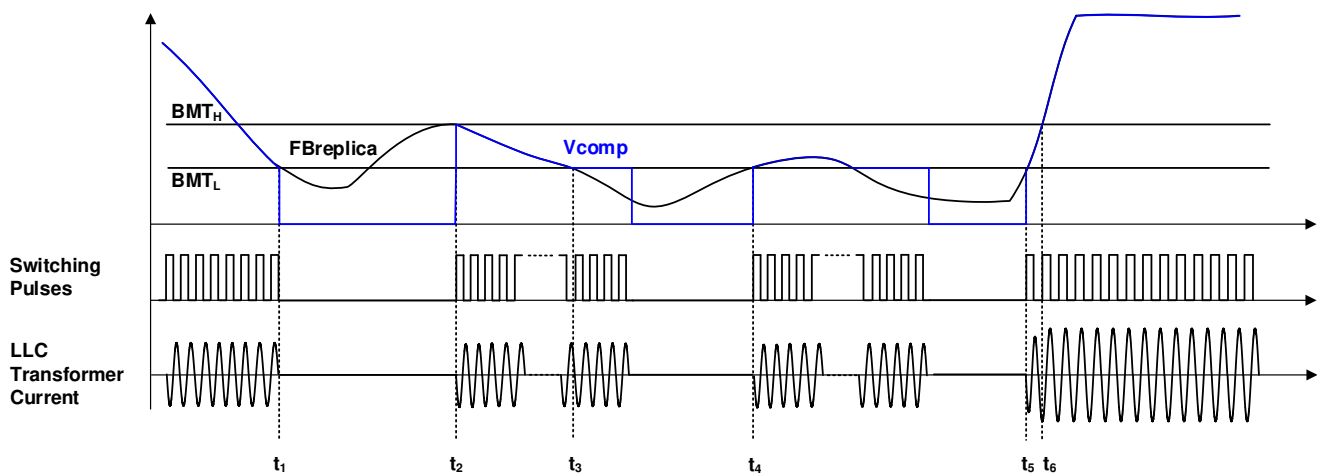

Figure 7-18. Burst Mode Switching Pattern when Soft On and Soft Off is Disabled

UCC25640x can also disable the burst mode by changing the BW pin resistance, as described in [Section 7.4.3.2](#). When burst mode is disabled, the switching does not stop even when FBreplca becomes lower than BMT_L . The pick higher block still works by picking the higher value of BMT_L and FBreplca for the control effort V_{comp} . In this case, BMT_L will limit the maximum switching frequency of LLC.

When burst mode is disabled, FBreplca needs to be higher than BMT_L at steady state. Otherwise, LLC output voltage will lose regulation as it continues deliver more energy than what is demanded from the feedback. For a transient period, it is ok for FBreplca to be lower than BMT_L .

7.4.3.1 Soft-Start and Burst-Mode Threshold

The soft-start programming and burst mode threshold programming are multiplexed on the pin LL/SS. In addition, when ZCS region operation happens, this pin is pulled down to ground through a diode to increase the switching frequency. The pin block diagram is shown in Figure 7-19.

Figure 7-20 shows the timing diagram of the LL/SS pin programming. It includes 5 phases:

- SS pull low phase - LL/SS pin is internally pulled low with a typical 1.2 kΩ resistor to ground.
- SS initial voltage program phase - The internal pull low is released. As shown in Figure 7-19, LL/SS pin is typically connected with a resistor divider from RVCC and a capacitor to ground. When the internal pull low circuit is released, LL/SS pin voltage can be charged up depending on the external resistor and capacitor. This phase ends when charge boot stage is completed and it has a fixed time of $t_{SSInitVolPrgm}$.
- Soft start phase - An internal constant current source charges the soft start capacitor right after the charge boot stage, and ends when FBreplica becomes lower than the LL/SS pin voltage. During this phase, LL/SS pin voltage is used as the control effort V_{comp} . The slow ramp up of LL/SS pin helps the LLC operate at a higher switching frequency when the output voltage is not established yet during startup. This can avoid the large inrush current during startup.
- BMT_L settling phase - When soft start phase is completed, LL/SS pin is used for burst mode threshold programming. As described in Section 7.4.3, two burst mode thresholds are used. During this phase, BMT_H is fixed at either 0.6V (1.2 V if BW option 7 is selected). BMT_L is also fixed which is determined by the programmed ratio of BMT_L/BMT_H . The typical duration of this phase is 600 μ s.
- BMT_L and BMT_H programming/setting phase - LL/SS pin is buffered at 3.5 V during this phase. Depending on the resistors connected to the pin, LL/SS pin could either sink or source current. If LL/SS pin sinks current, the current will be internally mirrored to flow through R_{LL} , and the voltage on R_{FB} is the programmed voltage of BMT_H . If LL/SS pin sources current, the programmed voltage of BMT_H is set to minimal. If the programmed voltage of BMT_H is different from the initial voltage, BMT_H ramps to the target value at a refresh frequency of every 200 μ s. The slow refresh frequency makes sure that BMT_H does not change due to the noise on LL/SS pin. BMT_L follows the change of BMT_H based on the programmed ratio of BMT_L/BMT_H .

The programmability of the SS initial voltage provides a freedom to limit the maximum switching frequency during startup. This helps to prevent hard switching due to excessively high switching frequency. For applications that require very high switching frequency during startup, an option is also provided to disable the SS initial voltage programming through BW pin, as described in Section 7.4.3.2. If this option is selected, LL/SS pin continues pull low with the internal 1.2 kΩ resistor during the SS initial voltage program phase.

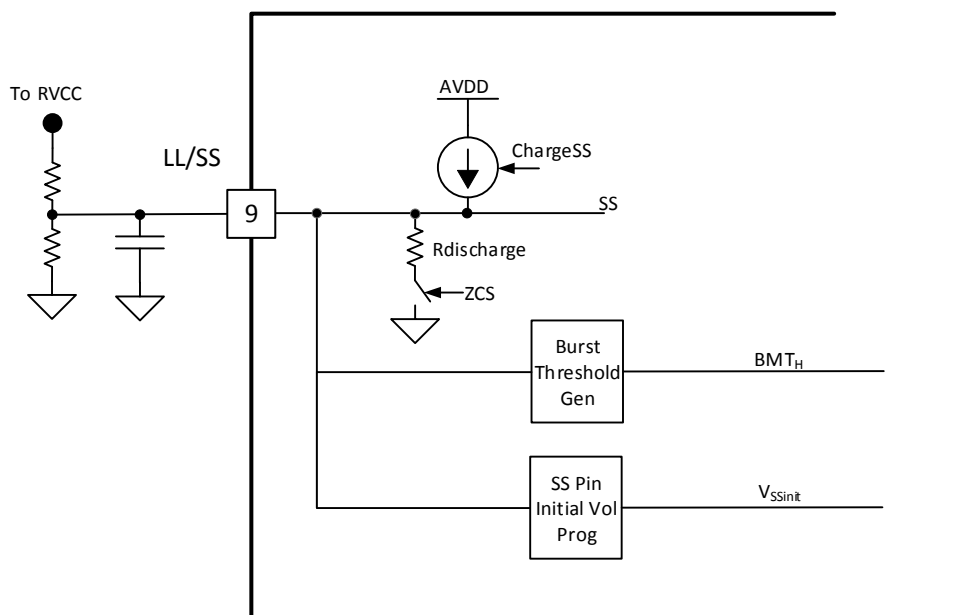

Figure 7-19. LL/SS Block Diagram

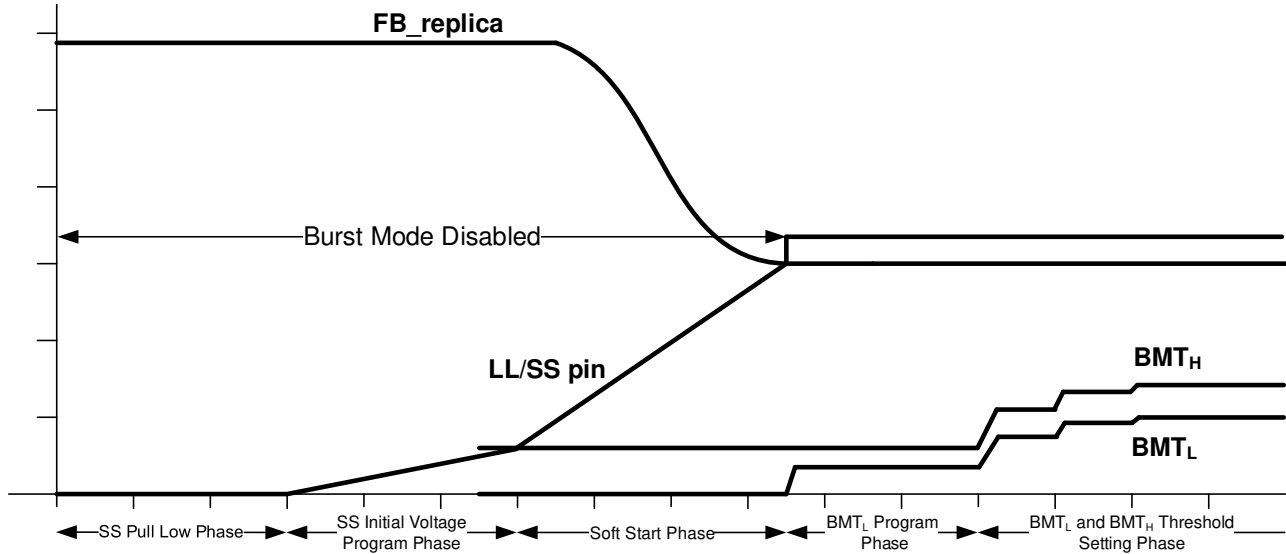

Figure 7-20. Timing Diagram of LL/SS Pin Programming

7.4.3.2 BMT_L/BMT_H Ratio Programming

As described in [Section 7.3.7](#), BW pin is multiplexed for BMT_L/BMT_H ratio programming. The programming phase happens only once before startup. After that, the BMT_L/BMT_H ratio is then fixed, until system restarts after a fault or power recycle. The programming phase occurs right before soft start begins. It sources a constant current and measures the voltage on the pin. Depending on the measured pin voltage, different ratio of BMT_L/BMT_H is selected as listed in [Table 7-2](#). The required BW equivalent resistance is listed in electrical characteristics section.

Other than selecting different BMT_L/BMT_H ratios, the option 5 also disables the LL/SS pin initial voltage program phase during startup, and the option 7 disables the burst mode.

Table 7-2. BMT_L/BMT_H Ratio Programming

Option	BMT_L/BMT_H
1	0.95
2	1
3	0.9
4	0.8
5	0.6 (LL/SS pin initial voltage programming disabled)
6	0.6
7	0.4 (Burst Mode Disabled)

7.4.4 System State Machine

Below is an overview of the system states sequence:

The state transition diagram starts from the un-powered condition of UCC25640x. For device variants that has HV startup, as soon as the AC input is plugged in, the internal JFET of the HV pin will be enabled and will start to deliver current from a source connected from the HV pin to the VCC capacitor. Once the VCC pin voltage exceeds its $VCC_{StartSwitching}$ threshold, the system state will change to JFETOFF. For device variants which does not have HV startup feature, there is no JFETon state. Once VCC exceeds its $VCC_{StartSwitching}$ threshold, the system state will change to JFETOFF. When the PFC output voltage reaches a certain level, the LLC is turned on. Before the LLC starts running, the LO pin is kept high to pull the HS node of the LLC bridge low, thus allowing the capacitor between the HB and HS pins to be charged from VCC via the bootstrap diode. UCC25640x will remain in the CHARGE_BOOT state for a certain time to ensure the boot capacitor is fully charged. When the LLC output voltage reaches a certain level, both PFC and LLC controllers get power from the LLC transformer bias winding. When the load drops below a certain level, the LLC operates in burst mode.

Fault conditions encountered by UCC25640x will cause normal operation to stop, or pause for a certain period of time followed by an automatic re-start. This is to ensure that while a persistent fault condition is present, it is not possible for the temperature of UCC25640x controller or the power converter to rise as a result of the repeated re-start attempts.

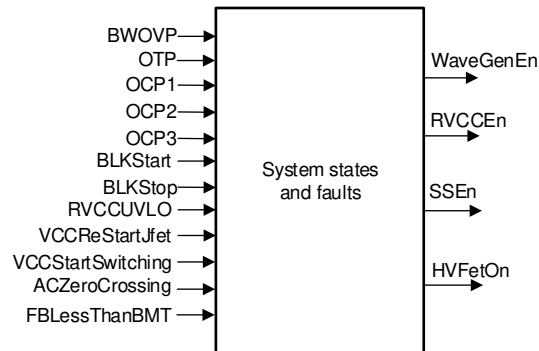

Figure 7-21. Block Diagram of System State Machine

Table 7-3 summarizes the inputs and outputs of Figure 7-21.

Table 7-3. System State Machine Block Inputs and Outputs

SIGNAL NAME	I/O	DESCRIPTION
BWOVP	I	Output over voltage fault
OTP	I	Over temperature fault
OCP1	I	Peak current fault
OCP2	I	Average current fault with 2 ms timer
OCP3	I	Average current fault with 50 ms timer
BLKStart	I	Bulk voltage is above start threshold
BLKStop	I	Bulk voltage is below stop threshold
RVCCUVLO	I	RVCC UVLO fault
VCCReStartJfet	I	VCC is below restart threshold
VCCStartSwitching	I	VCC is above start switching threshold
ACZeroCrossing	I	AC zero crossing is detected
WaveGenEn	O	Waveform generator enable
RVCCEn	O	RVCC enable
SSEn	O	Soft start enable
HVFetOn	O	Turn on or off JFET

The state machine is shown in [Figure 7-22](#) and the description of the states and state transition conditions are in the tables below.

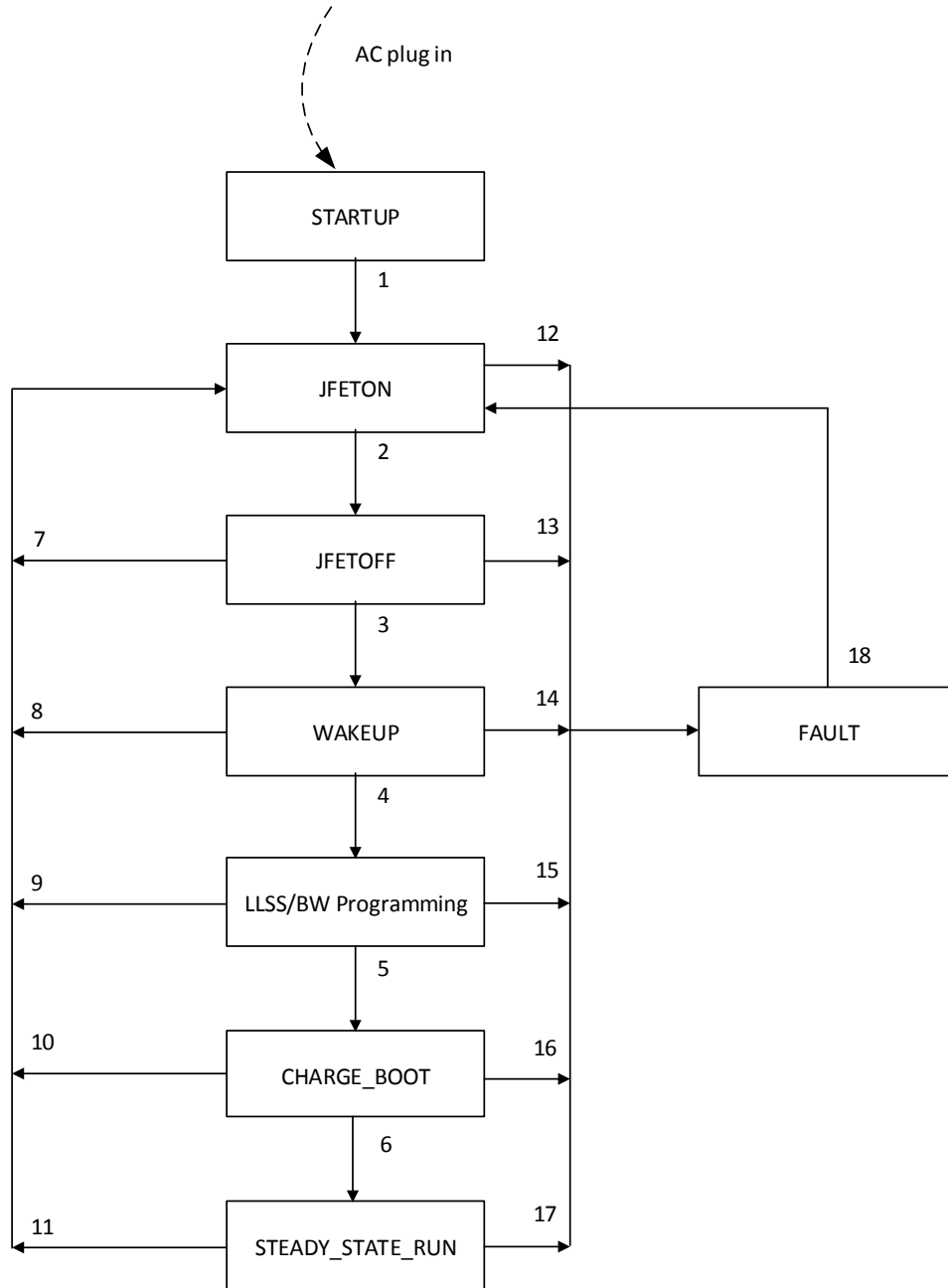

Figure 7-22. System State Machine Transition

Table 7-4. States in System State Machine

STATE	OUTPUT STATUS	DESCRIPTION
STARTUP	WaveGenEn = 0 RVCCEn = 0 SSEn = 0 HVFetOn = 0	This is the first state after AC input is plugged-in for the system to load trim.
JFETON	WaveGenEn = 0 RVCCEn = 0 SSEn = 0 HVFetOn = 1	In this state, the JFET is on. VCC is charged with a current source connected from HV pin. For device variants that does not have HV startup feature, this state does not exist.
JFETOFF	WaveGenEn = 0 RVCCEn = 1 SSEn = 0 HVFetOn = 0	When VCC is higher than VCCStartSwitching threshold, the JFET is turned off and the system enters JFETOFF state. The regulated RVCC is turned on. If RVCC is supplied to PFC voltage supply pin, PFC soft start begins.
WAKEUP	WaveGenEn = 0 RVCCEn = 1 SSEn = 0 HVFetOn = 0	When BLK voltage reaches BLKStart level, the system enters WAKEUP state and stays in WAKEUP state for a short time for the analog circuits to wake up.
LLSS/BW Programming	WaveGenEn = 0 RVCCEn = 1 SSEn = 0 HVFetOn = 0	In this state, the system goes through the LL/SS pin and BW pin programming phase.
CHARGE_BOOT	WaveGenEn = 0 RVCCEn = 1 SSEn = 0 HVFetOn = 0	In this state, the BOOT capacitor is charged by turning on the low-side switch for a certain period of time. The programmed initial voltage is buffered to LL/SS pin.
STEADY_STATE_RUN	WaveGenEn = 1 RVCCEn = 1 SSEn = 1 HVFetOn = 0	In this state, the waveform generator is enabled. Soft start module is enabled. The LLC starts to soft start. When soft start is done, the system enters normal operation.
FAULT	WaveGenEn = 0 RVCCEn = 0 SSEn = 0 HVFetOn = 0	In fault state, the waveform generator is disabled to stop switching. The system will stay in FAULT state for 1 s before re-start. The 1 s timer allows the system to cool down and prevents frequent repetitive start ups in case of a persistent fault.

Table 7-5. System State Machine Transition Conditions

STATE TRANSITION CONDITION	DESCRIPTION
1	System ready (trim load done)
2	VCCStartSwitching = 1 VCCReStartJfet = 0
3	BLKStart = 1 BLKStop = 0 RVCCUVLO = 0
4	BLKStart = 1 BLKStop = 0 RVCCUVLO = 0 FBLessThanBMT = 0
5	LLSS/BW programming done
6	Charge boot done
7	VCCReStartJfet = 1
8	VCCReStartJfet = 1
9	VCCReStartJfet = 1
10	VCCReStartJfet = 1
11	VCCReStartJfet = 1
12	OTP = 1
13	OTP = 1
14	OTP = 1
15	OTP = 1
16	OTP = 1
17	OTP = 1 or BLKStop = 1 or BWOVP = 1 or OCP1 = 1 or OCP 2 = 1 or OCP3 = 1 or RVCCUVLO = 1
18	1 s pause time out

Figure 7-23 and Figure 7-24 show the most commonly used state transition (assuming no faults during start up states so all the states are captured in the timing diagram). Many different ways of state transitions may happen according to the state machine, but are not captured in this section.

In Figure 7-24, a normal start up procedure is shown. The system enters normal operation and then a fault (OCP, OVP, or OTP) happens.

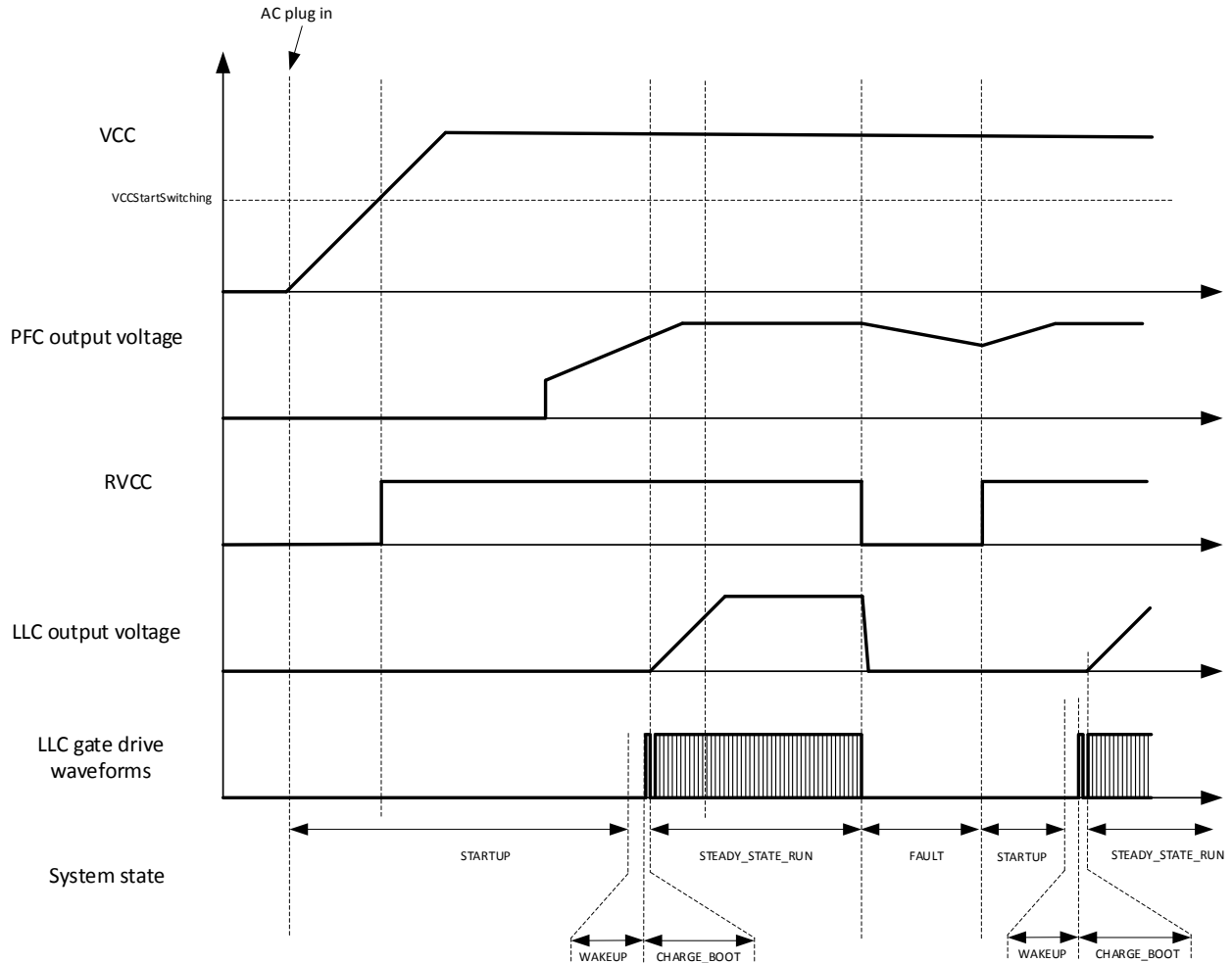

Figure 7-23. Timing Diagram of System State Machine for UCC256403

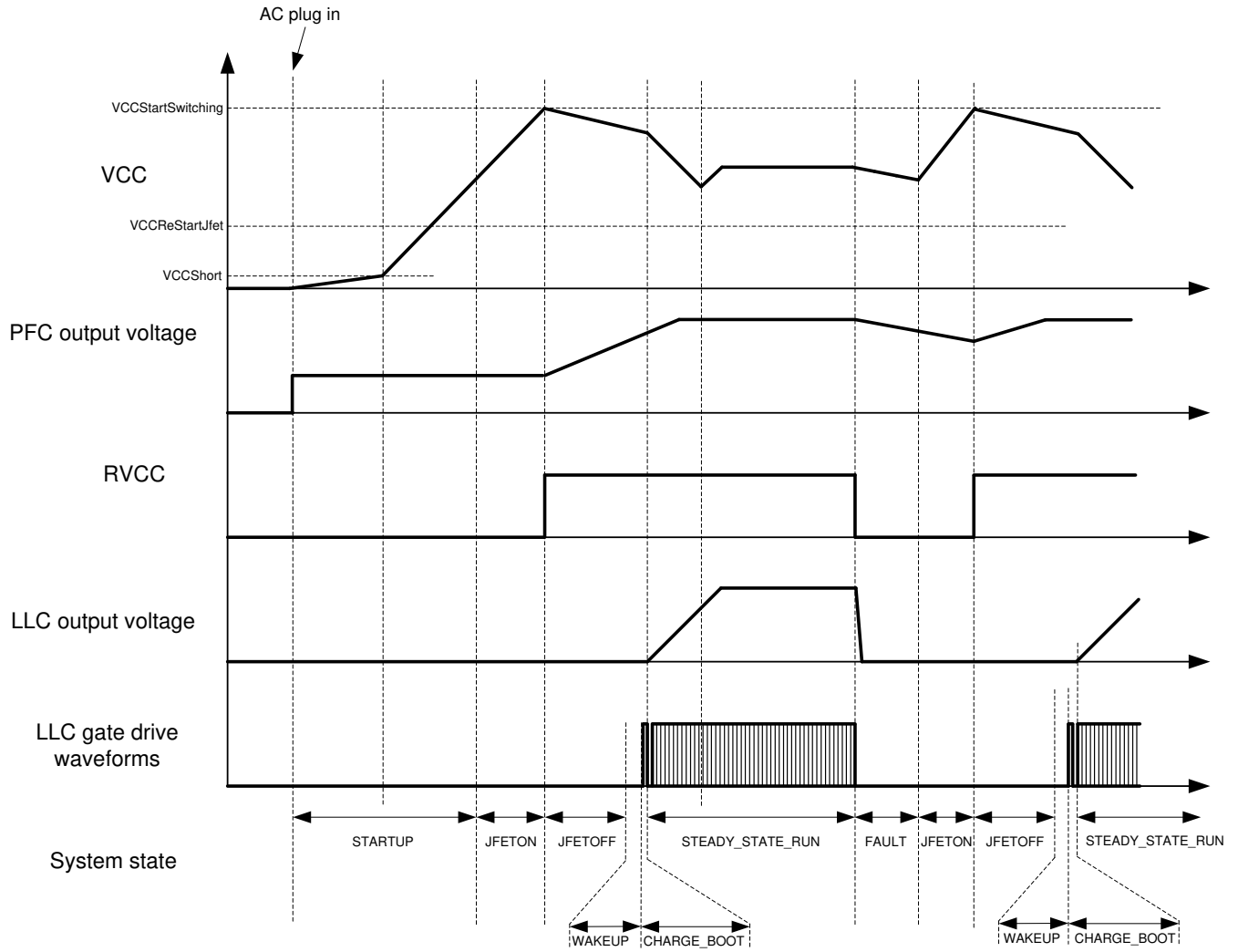

Figure 7-24. Timing Diagram of System State Machine for UCC256402 and UCC256404

Application and Implementation

Note

Information in the following applications sections is not part of the TI component specification, and TI does not warrant its accuracy or completeness. TI's customers are responsible for determining suitability of components for their purposes. Customers should validate and test their design implementation to confirm system functionality.

8.1 Application Information

UCC25640x can be used in a wide range of applications in which LLC topology is implemented. In order to make the part easier to use, TI has prepared a list of materials to demonstrate the features of the device:

- Full featured EVM hardware
- An excel design calculator
- Simulation models
- Application notes on Hybrid Hysteretic Control theory

In the following sections, a typical design example is presented.

8.2 Typical Application

Shown below is a typical half bridge LLC application using UCC25640x as the controller.

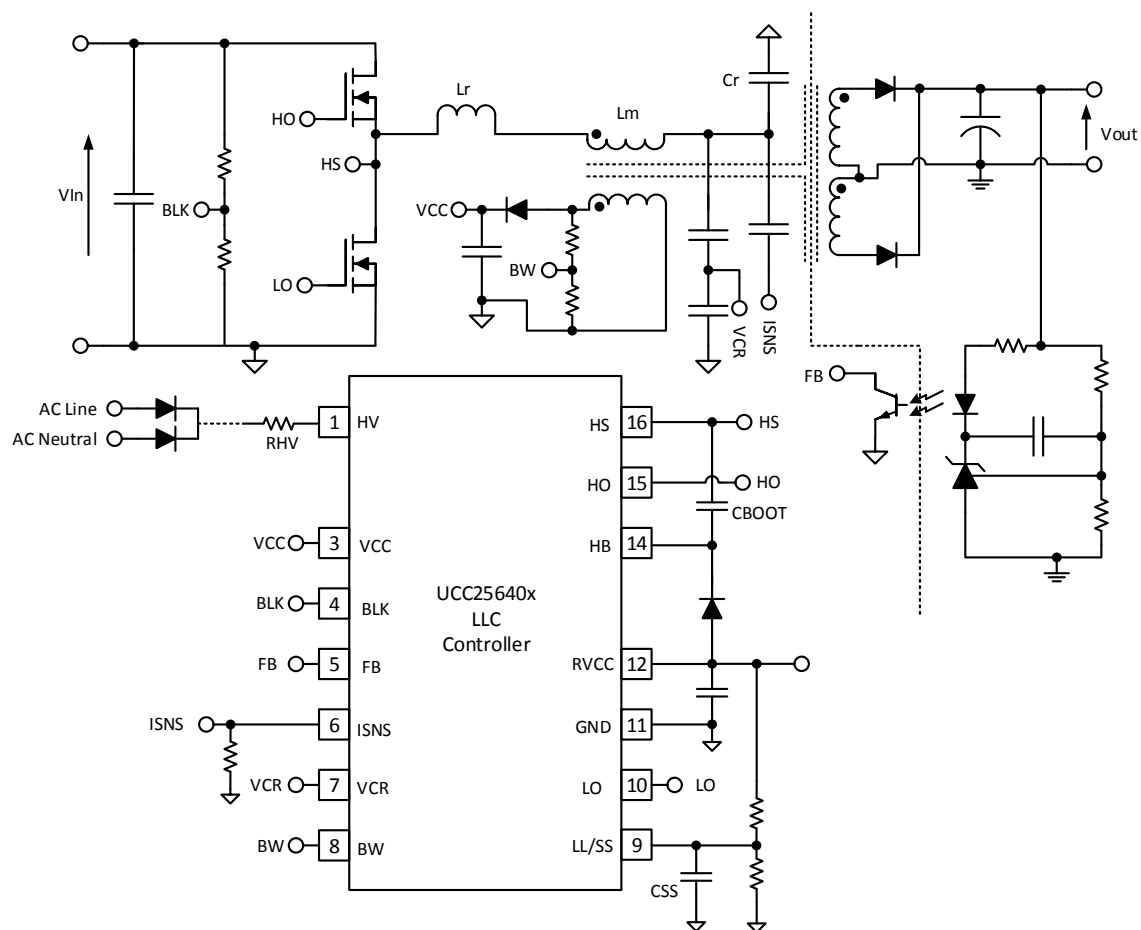

8.2.1 Design Requirements

The design specifications are summarized in [Table 8-1](#).

Table 8-1. System Design Specifications

PARAMETER	TEST CONDITIONS	MIN	TYP	MAX	UNITS
INPUT CHARACTERISTICS					
DC Voltage range		365	390	410	VDC
AC Voltage range		85		264	VAC
AC Voltage frequency		47		63	Hz
Input DC UVLO On			365		VDC
Input DC UVLO Off			315		VDC
OUTPUT CHARACTERISTICS					
Output voltage, VOUT	No load to full load		12		VDC
Output load current, IOUT	360 VDC to 410 VDC			15	A
Output voltage ripple	390 VDC and full load = 10 A		120		mVpp
SYSTEMS CHARACTERISTICS					
Resonant Frequency			100		kHz
Peak efficiency	390 VDC		92		
Operating temperature	Natural convection		25		°C

8.2.2 Detailed Design Procedure

8.2.2.1 LLC Power Stage Requirements

Start the design by deciding the LLC power stage component values. The LLC power stage design procedure outlined here follows the one given in the TI application note “Designing an LLC Resonant Half-Bridge Power Converters”. The application note contains a full explanation of the origin of each of the equations used. The equations given below are based on the First Harmonic Approximation (FHA) method commonly used to analyze the LLC topology. This method gives a good starting point for any design, but a final design requires an iterative approach combining the FHA results, circuit simulation, and hardware testing. An alternative design approach is given in TI application note SLUA733, LLC Design for UCC29950.

8.2.2.2 LLC Gain Range

First, determine the transformer turns ratio by the nominal input and output voltages.

$$N_{PS} = \frac{V_{IN(nom)} / 2}{V_{OUT(nom)}} = \frac{390 / 2}{12} = 16.25 \Rightarrow 16.5 \quad (4)$$

Then determine the LLC gain range $M_{G(min)}$ and $M_{G(max)}$. Assume there is a 0.5-V drop in the rectifier diodes (V_f) and an additional 0.5-V due to other losses (V_{loss}).

$$M_{G(min)} = N_{PS} \frac{V_{OUT(min)} + V_f}{V_{IN(max)} / 2} = 16.5 \frac{12 + 0.5}{410 / 2} = 1.006 \quad (5)$$

$$M_{G(max)} = N_{PS} \frac{V_{OUT(max)} + V_f + V_{loss}}{V_{IN(min)} / 2} = 16.5 \frac{12 + 0.5 + 0.5}{365 / 2} = 1.175 \quad (6)$$

8.2.2.3 Select L_n and Q_e

L_N is the ratio between the magnetizing inductance and the resonant inductance.

$$L_N = \frac{L_M}{L_R} \quad (7)$$

Q_E is the quality factor of the resonant tank.

$$Q_E = \frac{\sqrt{L_R / C_R}}{R_E} \quad (8)$$

In this equation, R_E is the equivalent load resistance.

Selecting L_N and Q_E values should result in an LLC gain curve, that intersects with $M_{G(\min)}$ and $M_{G(\max)}$ traces. The peak gain of the resulting curve should be larger than $M_{G(\max)}$. Details of how to select L_N and Q_E are not discussed here. They are available in the [UCC25640x Design Calculator](#).

In this case, the selected L_N and Q_E values are:

$$L_N = 6 \quad (9)$$

$$Q_E = 0.3 \quad (10)$$

8.2.2.4 Determine Equivalent Load Resistance

Determine the equivalent load resistance by [Equation 11](#).

$$R_E = \frac{8 \times N_{PS}^2}{\pi^2} \times \frac{V_{OUT(nom)}}{I_{OUT(nom)}} = \frac{8 \times 16.5^2}{\pi^2} \times \frac{12}{15} = 176.5 \Omega \quad (11)$$

8.2.2.5 Determine Component Parameters for LLC Resonant Circuit

Before determining the resonant tank component parameters, a nominal switching frequency (resonant frequency) should be selected. In this design, 100 kHz is selected as the resonant frequency.

$$f_0 = 100 \text{ kHz} \quad (12)$$

The resonant tank parameters can be calculated as the following:

$$C_R = \frac{1}{2\pi \times Q_E \times f_0 \times R_E} = \frac{1}{2\pi \times 0.3 \times 100 \text{ kHz} \times 176.5 \Omega} = 30.0 \text{ nF} \quad (13)$$

$$L_R = \frac{1}{(2\pi \times f_0)^2 C_R} = \frac{1}{(2\pi \times 100 \text{ kHz})^2 \times 30.0 \text{ nF}} = 84.4 \mu\text{H} \quad (14)$$

$$L_M = L_N \times L_R = 6 \times 84.4 \mu\text{H} = 506.4 \mu\text{H} \quad (15)$$

After the preliminary parameters are selected, find the closest actual component value that is available, re-check the gain curve with the selected parameters, and then run time domain simulation to verify the circuit operation.

The following resonant tank parameters are:

$$C_R = 30 \text{ nF} \quad (16)$$

$$L_R = 85 \mu\text{H} \quad (17)$$

$$L_M = 510 \mu\text{H} \quad (18)$$

Based on the final resonant tank parameters, the resonant frequency can be calculated:

$$f_0 = \frac{1}{2\pi \sqrt{L_R C_R}} = \frac{1}{2\pi \sqrt{30 \text{ nF} \times 85 \mu\text{H}}} = 99.7 \text{ kHz} \quad (19)$$

Based on the new LLC gain curve, the normalized switching frequency at maximum and minimum gain are given by:

$$f_{N(Mgmax)} = 0.7 \quad (20)$$

$$f_{N(Mgmin)} = 1.0 \quad (21)$$

The maximum and minimum switching frequencies are:

$$f_{SW(Mgmax)} = 69.8 \text{ kHz} \quad (22)$$

$$f_{SW(Mgmin)} = 99.7 \text{ kHz} \quad (23)$$

8.2.2.6 LLC Primary-Side Currents

The primary-side currents are calculated for component selection purposes. The currents are calculated based on a 110% overload condition.

The primary side RMS load current is given by:

$$I_{OE} = \frac{\pi}{2\sqrt{2}} \times \frac{I_o}{n} = \frac{\pi}{2\sqrt{2}} \times \frac{1.1 \times 15 \text{ A}}{16.5} = 1.111 \text{ A} \quad (24)$$

The RMS magnetizing current at minimum switching frequency is given by:

$$I_M = \frac{2\sqrt{2}}{\pi} \times \frac{N_{PS} V_{OUT}}{\omega L_M} = \frac{2\sqrt{2}}{\pi} \times \frac{16.5 \times 12}{2\pi \times 64.8 \text{ kHz} \times 510 \mu\text{H}} = 0.797 \text{ A} \quad (25)$$

The total current in resonant tank is given by:

$$I_R = \sqrt{I_M^2 + I_{OE}^2} = \sqrt{(1.111 \text{ A})^2 + (0.797 \text{ A})^2} = 1.367 \text{ A} \quad (26)$$

8.2.2.7 LLC Secondary-Side Currents

The total secondary side RMS load current is the current referred from the primary side current (I_{OE}) to the secondary side.

$$I_{OES} = N_{PS} \times I_{OE} = 16.5 \times 1.111 A = 18.327 A$$

(27)

In this design, the transformer's secondary side has a center-tapped configuration. The current of each secondary transformer winding is calculated by:

$$I_{WS} = \frac{\sqrt{2} \times I_{OES}}{2} = \frac{\sqrt{2} \times 18.327 A}{2} = 12.959 A$$

(28)

The corresponding half-wave average current is:

$$I_{SAV} = \frac{\sqrt{2} \times I_{OES}}{\pi} = \frac{\sqrt{2} \times 18.327 A}{\pi} = 8.250 A$$

(29)

8.2.2.8 LLC Transformer

A bias winding is needed in order to utilize the HV self start up function. It is recommended to design the bias winding so that the VCC voltage is greater than 13 V.

The transformer can be built or purchased according to these specifications:

- Turns ratio: Primary : Secondary : Bias = 33 : 2 : 3
- Primary terminal voltage: 450 V_{ac}
- Primary magnetizing inductance: L_M = 510 μH
- Primary side winding rated current: I_R = 1.367 A
- Secondary terminal voltage: 36 V_{ac}
- Secondary winding rated current: I_{WS} = 12.959 A
- Minimum switching frequency: 69.8 kHz
- Maximum switching frequency: 99.7 kHz
- Insulation between primary and secondary sides: IEC60950 reinforced insulation

The minimum operating frequency during normal operation is calculated above. Please note that for some applications that operate as a wide input LLC where the PFC may be shut off in standby mode, the operating frequency may be much lower during heavy load shutdown and the LLC can operate at just above the ZCS boundary which is a lower frequency. The magnetic components in the resonant circuit, the transformer and resonant inductor, should be rated to operate at this lower frequency.

8.2.2.9 LLC Resonant Inductor

The AC voltage across the resonant inductor is given by its impedance multiplied by the current:

$$V_{L_R} = \omega L_R I_R = 2\pi \times 69.8\text{kHz} \times 85\mu\text{H} \times 1.367\text{A} = 50.946\text{V} \quad (30)$$

The inductor can be built or purchased according to the following specifications:

- Inductance: L_R = 85 μH
- Rated current: I_R = 1.367 A
- Terminal AC voltage: 50.946 V
- Frequency range: 69.8 kHz to 99.7 kHz

Please note some designs may utilize the leakage inductance of the transformer as the resonant inductance and do not require an external resonant inductor.

8.2.2.10 LLC Resonant Capacitor

This capacitor carries the full-primary current at the switching frequency. A low dissipation factor capacitor is needed to prevent overheating.

The AC voltage across the resonant capacitor is given by its impedance multiplied by the current.

$$V_{C_R} = \frac{I_R}{\omega C_R} = \frac{1.367\text{A}}{2\pi \times 69.8\text{kHz} \times 30\text{nF}} = 104.0\text{V} \quad (31)$$

$$V_{CR(ms)} = \sqrt{\left(\frac{V_{IN(max)}}{2}\right)^2 + V_{CR}^2} = \sqrt{\left(\frac{410}{2}\right)^2 + 104.0^2} = 229.9V \quad (32)$$

Peak voltage:

$$V_{CR(peak)} = \frac{V_{IN(max)}}{2} + \sqrt{2}V_{CR} = \frac{410}{2} + \sqrt{2} \times 104.0 = 352.0V \quad (33)$$

Valley voltage:

$$V_{CR(valley)} = \frac{V_{IN(max)}}{2} - \sqrt{2}V_{CR} = \frac{410}{2} - \sqrt{2} \times 104.0 = 58.0V \quad (34)$$

Rated current:

$$I_R = 1.367A \quad (35)$$

8.2.2.11 LLC Primary-Side MOSFETs

Each MOSFET sees the input voltage as its maximum applied voltage. Choose the MOSFET voltage rating to be 1.5 times of the maximum bulk voltage:

$$V_{QLLC(peak)} = 1.5 \times V_{IN(max)} = 615V \quad (36)$$

Choose the MOSFET current rating to be 1.1 times of the maximum primary side RMS current:

$$I_{QLLC} = 1.1 \times I_R = 1.504A \quad (37)$$

8.2.2.12 LLC Rectifier Diodes

The voltage rating of the output diodes is given by:

$$V_{DB} = 1.2 \times \frac{V_{IN(max)}}{N_{PS}} = 1.2 \times \frac{410}{16.5} = 29.82V$$

(38)

The current rating of the output diodes is given by:

$$I_{SAV} = \frac{\sqrt{2} \times I_{OES}}{\pi} = \frac{\sqrt{2} \times 18.329}{\pi} = 8.250 A$$

(39)

8.2.2.13 LLC Output Capacitors

The LLC converter topology does not require an output filter although a small second stage filter inductor may be useful in reducing peak-to-peak output noise. Assuming that the output capacitors carry the rectifier's full wave output current then the capacitor ripple current rating is:

$$I_{RECT} = \frac{\pi}{2\sqrt{2}} I_{OUT} = \frac{\pi}{2\sqrt{2}} \times 15 = 16.66 \text{ A} \quad (40)$$

Use 20 V rating for 12-V output voltage:

$$V_{LLCcap} = 20 \text{ V} \quad (41)$$

The capacitor's RMS current rating is:

$$I_{C(out)} = \sqrt{\left(\frac{\pi}{2\sqrt{2}} I_{OUT}\right)^2 - I_{OUT}^2} = \sqrt{\left(\frac{\pi}{2\sqrt{2}} \times 15\right)^2 - 15^2} = 7.251 \text{ A} \quad (42)$$

Solid Aluminum capacitors with conductive polymer technology have high ripple-current ratings and are a good choice, especially if the design is required to operate at colder temperatures. The ripple-current rating for a single capacitor may not be sufficient so multiple capacitors are often connected in parallel.

The ripple voltage at the output of the LLC stage is a function of the amount of AC current that flows in the capacitors. To estimate this voltage, assume that all the current, including the DC current in the load, flows in the filter capacitors.

$$ESR_{max} = \frac{V_{OUT(pk-pk)}}{I_{RECT(pk)}} = \frac{0.12 \text{ V}}{2 \frac{\pi}{4} \times 15 \text{ A}} = 5.1 \text{ m}\Omega \quad (43)$$

The capacitor specifications are:

- Voltage Rating: 20 V
- Ripple Current Rating: 7.251 A
- ESR: < 5.1 mΩ

8.2.2.14 HV Pin Series Resistors

Multiple resistors are connected in series with HV pin to limit the power dissipation of the UCC25640x device. The recommended series resistor with HV pin is 5 kΩ.

8.2.2.15 BLK Pin Voltage Divider

BLK pin senses the LLC input voltage and determines when to turn on and off the LLC converter. Different versions of UCC25640x have different BLK thresholds.

Choose bulk startup voltage at 365 V, then the BLK resistor divider ratio can be calculated as below:

$$k_{BLK} = \frac{365 V}{1 V} = 365 \quad (44)$$

The desired power consumption of the BLK pin resistor divider is $P_{BLKsns} = 10 \text{ mW}$. The BLK sense resistor total value is given by:

$$R_{BLKsns} = \frac{V_{IN(nom)}^2}{P_{BLKsns}} = \frac{390^2}{0.01} = 15.21 M\Omega \quad (45)$$

The lower BLK divider resistor value is given by:

$$R_{BLKlower} = \frac{R_{BLKsns}}{k_{BLK}} = \frac{15.21 M\Omega}{365} = 41.67 k\Omega \quad (46)$$

A standard value of 41.2 kΩ is selected for $R_{BLKlower}$. The higher BLK divider resistor value is given by:

$$R_{BLKupper} = R_{BLKsns} - R_{BLKlower} = 15.17 M\Omega \quad (47)$$

A standard value of 3x 4.99 MΩ in series is selected for $R_{BLKupper}$. The actual bulk voltage thresholds can be calculated:

$$V_{BulkStart} = 365 V \quad (48)$$

$$V_{BulkStop} = 365 V \times \frac{0.9}{1} = 328.5 V \quad (49)$$

8.2.2.16 ISNS Pin Differentiator

ISNS pin sets the over current protection level. OCP1 is peak current protection level; OCP2 and OCP3 are average current protection levels. The typical threshold voltages are 4.0 V, 0.6 V, and 0.43 V, respectively.

Set OCP3 level at 130% of full load. Thus, the sensed average input current level at full load is given by:

$$V_{ISNSfullload} = \frac{0.43V}{130\%} = 0.331V \quad (50)$$

The current sense ratio can then be calculated:

$$k_{ISNS} = \frac{V_{ISNSfullload}}{\left(\frac{P_{OUT}}{\eta} \times \frac{1}{V_{bulknom}}\right)} = \frac{0.331V}{\left(\frac{180W}{0.92} \times \frac{1}{390V}\right)} = 0.66\Omega \quad (51)$$

Select a current sense capacitor first, since there are less high voltage capacitor choices than resistors:

$$C_{ISNS} = 150 pF \quad (52)$$

Then calculate the required ISNS resistor value:

$$R_{ISNS} = \frac{k_{ISNS}C_r}{C_{ISNS}} = \frac{0.66\Omega \times 30 nF}{150 pF} = 132 \Omega \quad (53)$$

After the current sense ratio is determined, the peak ISNS pin voltage at full load can be calculated:

$$V_{ISNSpeak} = \sqrt{2}I_r \times k_{ISNS} = \sqrt{2} \times 1.367 A \times 0.66 \Omega = 1.29 V \quad (54)$$

The peak resonant current at OCP1 level is given by:

$$I_{respeakOCP1} = \frac{4V \times C_R}{R_{ISNS} \times C_{ISNS}} = \frac{4V \times 30nF}{133\Omega \times 150pF} = 6.02 A \quad (55)$$

The peak secondary-side current at OCP1 level is given by:

$$I_{secpeakOCP1} = I_{respeakOCP1} \times N_{PS} = 6.02A \times 16.5 = 99.33A \quad (56)$$

8.2.2.17 VCR Pin Capacitor Divider

The capacitor divider on the VCR pin sets two parameters: (1) the divider ratio of the resonant capacitor voltage; (2) the amount of frequency compensation to be added. The first criteria the capacitor divider needs to meet is that under over load condition, the peak-to-peak voltage on the VCR pin is within 6 V. It is recommended to size the VCR capacitance to give a total peak to peak voltage between 3 V and 4.5 V at full load with the frequency compensation ramp contributing between 1 V and 2 V to the total VCR peak to peak voltage. For this design, the VCR pin capacitance was selected to give a maximum peak to peak voltage of approximately 4.25 V at full load with the internal ramp contributing 1.75 V to the total VCR waveform.

The required VCR capacitance can be calculated directly from the resonant capacitor peak to peak voltage and the minimum expected switching frequency.

$$V_{CR(pk-pk)} = V_{CR(peak)} - V_{CR(valley)} = 352V - 58V = 294V \quad (57)$$

Based on the expected peak to peak resonant capacitor voltage, the required capacitor divider ratio can be derived

$$k_{CapDiv} = \frac{V_{CR(pk-pk)}}{V_{VCRpin(pk-pk)} - V_{Ramp(pk-pk)}} = \frac{294V}{4.25V - 1.75V} = 117.6 \quad (58)$$

From the expected minimum switching frequency, the lower VCR capacitance can be derived

$$C_{VCRlower} = \frac{1}{V_{Ramp(pk-pk)}} \times \frac{I_{Ramp}}{2 \times F_{SW_min}} = \frac{1}{1.75V} \times \frac{2mA}{2 \times 69.8kHz} = 8.2nF \quad (59)$$

A standard value of 8.2 nF is chosen for the lower VCR capacitor. From the selected lower VCR capacitor and calculated capacitor divider ratio, the upper VCR capacitance is given by:

$$C_{VCRupper} = \frac{C_{VCRlower}}{k_{CapDiv} - 1} = \frac{8.2nF}{117.6 - 1} = 70.6pF \quad (60)$$

A standard value of 68 pF is selected for the upper VCR capacitor. From the selected upper and lower VCR capacitors, the actual peak to peak voltage on the VCR pin can be calculated

$$k_{\text{CapDiv}} = \frac{C_{\text{VCRlower}}}{C_{\text{VCRupper}}} + 1 = \frac{8.2\text{nF}}{68\text{pF}} + 1 = 121.59 \quad (61)$$

$$V_{\text{VCRpin(pk-pk)}} = \frac{1}{C_{\text{VCRlower}}} \times \frac{I_{\text{Ramp}}}{2 \times F_{\text{SW(Mgmin)}}} + \frac{V_{\text{CR(pk-pk)}}}{k_{\text{CapDiv}}} = \frac{1}{8.2\text{nF}} \times \frac{2\text{mA}}{2 \times 69.8\text{kHz}} + \frac{294\text{V}}{121.59} = 4.17\text{V} \quad (62)$$

8.2.2.18 BW Pin Voltage Divider

The BW pin programs the ratio between burst mode entry and exit thresholds as well as senses the output voltage through the bias winding and protects the power stage from over voltage. The nominal output voltage is 12 V. The bias winding has 3 turns, and the secondary side winding has 2 turns. Assuming there is a 0.5-V drop in the rectifier diodes (V_f) and a further 0.5-V drop due to other losses (V_{loss}), the nominal voltage of the bias winding is given by:

$$V_{BiasWindingNom} = (12V + 0.5V + 0.5V) \times \frac{3}{2} = 19.5V \quad (63)$$

The desired OVP threshold in this design is 140% of the nominal value. The OVP threshold level in UCC25640x device is 4 V, so the nominal BW pin voltage is given by:

$$V_{BWnom} = \frac{4V}{140\%} = 2.86V \quad (64)$$

The required BW divider ratio is then given by:

$$k_{BW} = \frac{V_{BiasWindingNom} \times \eta_{OVP}}{V_{BW OVP}} = \frac{19.5V \times 140\%}{4V} = 6.825 \quad (65)$$

In this design, the burst mode threshold ratio is chosen to be 0.6 (Option 6). The target programming resistance is then:

$$R_{BMT_Program} = 4.59k\Omega \quad (66)$$

The lower BW resistor can be calculated by:

$$R_{BWlower} = R_{BMT_Program} \times \left(1 + \frac{1}{k_{BW} - 1}\right) = 4.59k\Omega \times \left(1 + \frac{1}{6.825 - 1}\right) = 5.38k\Omega \quad (67)$$

A standard value of 5.36 kΩ is chosen for the lower BW resistor.

The upper resistor can be calculated by:

$$R_{\text{BWUpper}} = R_{\text{BMWLower}} \times \left(\frac{V_{\text{BiasWindingNom}} - V_{\text{BWNom}}}{V_{\text{BWNom}}} \right) = 5.36\text{k}\Omega \times \left(\frac{19.5\text{V} - 2.86\text{V}}{2.86\text{V}} \right) = 31.32\text{k}\Omega$$

(68)

A standard value of 30.9 kΩ is chosen for the upper BW resistor.

8.2.2.19 Soft Start and Burst Mode Programming

The LL/SS and BW pins allow the designer to select a burst mode threshold as well as program hysteresis for entering and exiting burst mode. The resistor divider of connected to the LL/SS pin sets the BMT_H threshold while the BW pin sets the ratio between BMT_L and BMT_H . In addition to programming the burst mode threshold, the LL/SS pin provides the capability to program an initial voltage onto the LL/SS pin in order to limit the maximum switching frequency during startup. For initial selection of LL/SS components, it is recommended to select an initial LL/SS pin voltage between 0 V and 1 V and to select burst mode threshold between 1 V and 2 V. The LL/SS pin parameters can be fine tuned later based on bench measurement.

In this design, an initial LL/SS pin voltage of 0.3 V and a BMT_H threshold of 0.6 V are selected. The soft start capacitor sets how quickly the voltage on the soft start capacitor rises. The soft start time varies with load condition. At full load or over load condition, the soft start time is the longest. It is not easy to calculate the exact soft start time value. However, it can be estimated that under full load condition, the longest possible soft start time is determined by how quickly the soft start pin voltage rises to the maximum VCR peak to peak voltage. For a start up time of 7.5 ms, the soft start capacitor is sized to be the following:

$$C_{LL/SS} = I_{SS} \times \frac{T_{SS_Max}}{V_{VCR(pk-pk)} - V_{LL/SS_precharge}} = 37.5\mu A \times \frac{7.5ms}{4.17V - 0.3V} = 72.7nF \quad (69)$$

A standard value of 68nF is selected for the soft start capacitor. In order to properly select the resistors on LL/SS, first define R_{TH} as the equivalent resistance on the LL/SS pin and V_{TH} as the equivalent voltage source on the LL/SS pin.

$$R_{TH} = R_{LL/SS_Upper} \parallel R_{LL/SS_Lower} \quad (70)$$

$$V_{TH} = \frac{R_{TH} \times RVCC}{R_{LL/SS_Upper}} \quad (71)$$

During the SS pull low phase, the voltage on the LL/SS pin is internally pulled down through a 1.2 kΩ resistor. During the SS initial program phase, the internal pulldown is released and the soft start capacitor is allowed to naturally charge up from RVCC. The total voltage offset on the LL/SS soft start capacitor can be calculated using the equation below.

$$V_{ssinit} = \frac{1.2k\Omega \times RVCC}{R_{LL/SS_Upper}} + V_{TH} \left(1 - e^{\left(\frac{-t_{SSinitPrgm}}{C_{SS}} \right)} \right) \quad (72)$$

Substituting for $RVCC/R_{LL/SS_Upper}$ and using a linear approximation for the exponential term, the equation can be simplified to the following.

$$V_{ssinit} = \frac{1.2k\Omega \times V_{TH}}{R_{TH}} + \frac{V_{TH} \times t_{SSInitVolPrgm}}{R_{TH} \times C_{SS}} \quad (73)$$

The current used by the LL/SS pin to program BMT_H , I_{BMT} , has the following relationships. I_{BMT} can be directly solved for based on the desired BMT_H threshold.

$$I_{BMT} = \frac{BMT_H}{R_{LL}} = \frac{0.6V}{98k\Omega} = 6.12\mu A \quad (74)$$

$$I_{BMT} = \frac{V_{TH} - 3.5V}{R_{TH}} \quad (75)$$

Rearranging [Equation 73](#), V_{TH} and R_{TH} can now be calculated.

$$V_{TH} = \frac{3.5V}{1 - \frac{I_{BMT}}{V_{ssinit}} \left(1.2k\Omega + \frac{t_{SSInitVolPrgm}}{C_{SS}} \right)} = \frac{3.5V}{1 - \frac{6.12\mu A}{0.3V} \left(1.2k\Omega + \frac{776\mu s}{68nF} \right)} = 4.71V \quad (76)$$

$$R_{TH} = \frac{4.71V - 3.5V}{I_{BMT}} = 197k\Omega \quad (77)$$

Values for R_{LL/SS_Upper} and R_{LL/SS_Lower} can be determined from V_{TH} and R_{TH}

$$R_{LL/SS_Upper} = \frac{R_{TH} \times RVCC}{V_{TH}} = \frac{197k\Omega \times 13V}{4.71V} = 544k\Omega \quad (78)$$

A standard value of 549 k Ω is selected for R_{LL/SS_Upper} .

$$R_{LL/SS_Lower} = \frac{R_{TH} \times R_{LL/SS_Upper}}{R_{LL/SS_Upper} - R_{TH}} = \frac{197k\Omega \times 549k\Omega}{549k\Omega - 197k\Omega} = 307k\Omega$$

(79)

A standard value of 316 kΩ is selected for R_{LL/SS_Lower} .

8.2.3 Application Curves

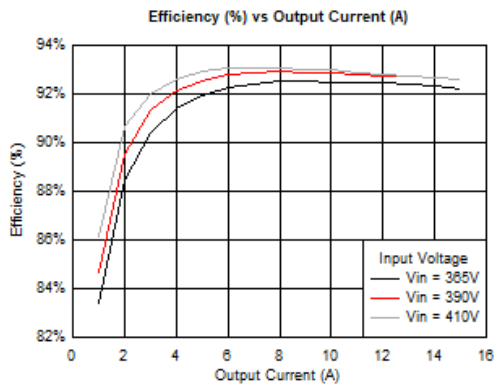

Figure 8-1. Efficiency

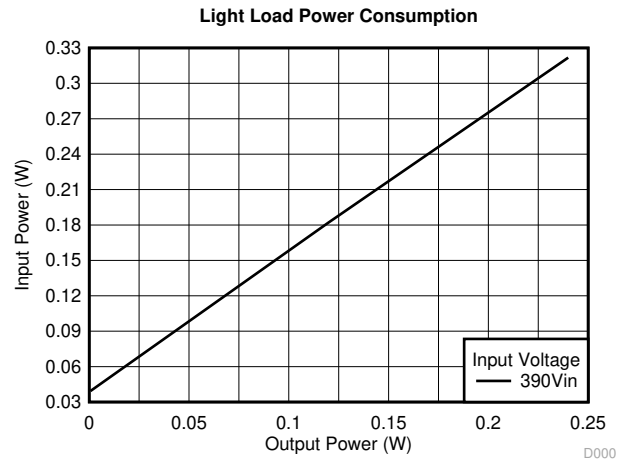

Figure 8-2. Light Load Power Consumption

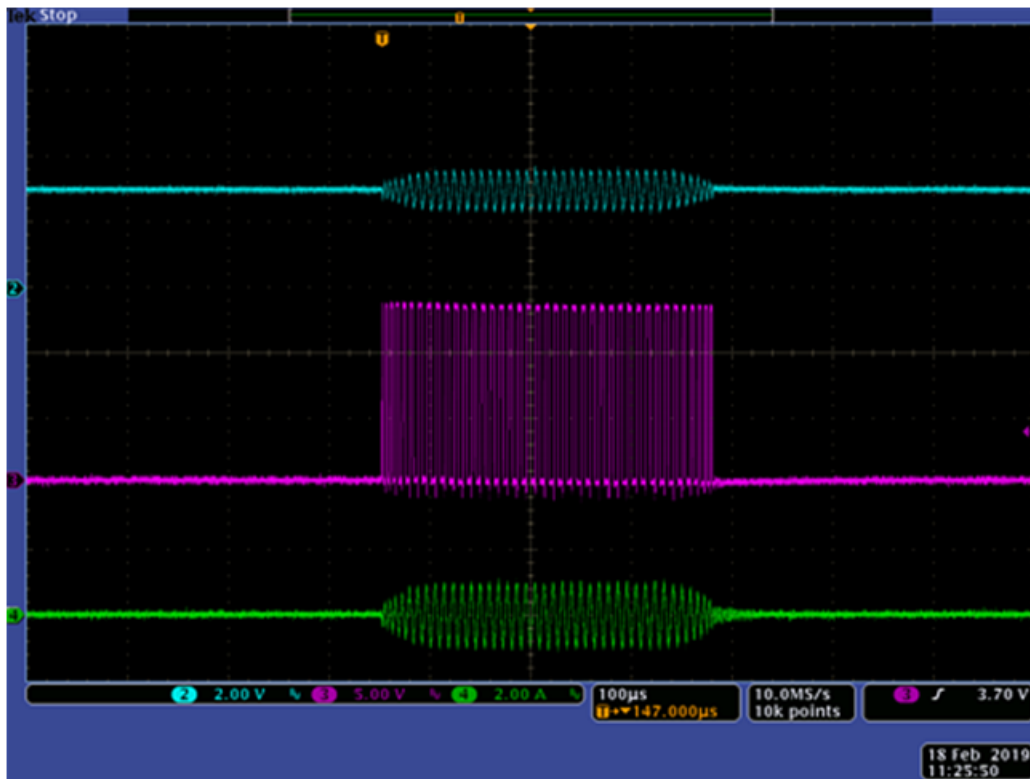

Figure 8-3. Burst Mode with Soft On/Off (Ch2 = VCR, Ch3 = LO, Ch4 = Resonant Current)

8 Power Supply Recommendations

8.1 VCC Pin Capacitor

The VCC capacitor should be sized based on the total start-up charge required by the system. The start-up charge will mostly be consumed by the gate driver circuit. Thus the total start-up charge can be estimated by the start-up switching frequency, MOSFET gate charge, and the soft-start time.

Assume the total start-up charge required by the system is shown in [Equation 80](#)

$$Q_{tot} = 1.6 \text{ mC} \tag{80}$$

During PFC and LLC startup phase, the maximum VCC voltage drop allowed is

$$V_{ccdropmax} = 26 \text{ V} - 9.65 \text{ V} = 16.35 \text{ V} \tag{81}$$

The minimum VCC capacitor needed:

$$C_{VCC} = \frac{Q_{tot}}{V_{ccdropmax}} = 97.86 \text{ } \mu\text{F} \tag{82}$$

Choose at least 100 μF capacitor or combination of capacitors.

8.2 Boot Capacitor

During burst off period, power consumed by the high-side gate driver from the HB pin must be drawn from C_{BOOT} and will cause its voltage to decay. At the start of the next burst period there must be sufficient voltage remaining on C_{BOOT} to power the high-side gate driver until the conduction period of LO allows it to be replenished from C_{RVCC} . The power consumed by the high-side driver during this burst off period will therefore have a direct impact on the size and cost of capacitors that must be connected to HB and RVCC.

Assume the system has a maximum burst off period of 150 ms and the bootstrap diode has a forward voltage drop of 1V. Target a minimum bootstrap voltage of 8 V to avoid UVLO fault. The maximum allowable voltage drop on the boot capacitor is:

$$V_{bootmaxdrop} = V_{RVCC} - V_{bootforwarddrop} - 8 \text{ V} = 13 \text{ V} - 1 \text{ V} - 8 \text{ V} = 4 \text{ V} \tag{83}$$

Boot capacitor can then be sized:

$$C_{boot} = \frac{I_{BOOT_QUIESCENT} \times t_{max\ off}}{V_{bootforwarddrop}} = \frac{62\mu A \times 150ms}{4V} = 2.32\mu F$$

(84)

8.3 RVCC Pin Capacitor

The RVCC capacitor needs to be at least 5 times greater than boot capacitor. In addition, sizing of the RVCC capacitor depends on the stability of the RVCC LDO. If the load is light on RVCC, smaller capacitors can be used. The larger the load, the larger the capacitor is needed. In a typical system, the RVCC LDO powers the PFC and LLC gate drivers.

9 Layout

9.1 Layout Guidelines

- Put a 2.2- μ F ceramic capacitor on VCC pin in addition to the energy storage electrolytic capacitor. The 2.2- μ F ceramic capacitor should be put as close as possible to the VCC pin.
- RVCC pin should have a bypass capacitor of 4.7 μ F or more. It is recommended to add a 0.1- μ F ceramic capacitor in addition to the 4.7 μ F. The capacitors should be put as close as possible to the RVCC pin. RVCC cap is recommended to be size at least 5 times of boot capacitor.
- Minimum recommended boot capacitor, C_{BOOT} , is 0.1 μ F. The minimum value of the boot capacitor needs to be determined by the minimum burst frequency. The boot capacitor should be large enough to hold the bootstrap voltage during the lowest burst frequency. Please refer to the boot leakage current in the electrical table.
- Signal ground and power ground should be single-point connected. Power ground is recommended to connect to the negative terminal of the LLC input bulk capacitor.
- The filtering capacitors for ISNS and BLK should be put as close as possible to the pins.
- The bottom capacitor on VCR should be put as close as possible to the VCR pin.
- FB trace should be as short as possible
- Soft-start capacitor should be put as close as possible to LL/SS pin
- Use film capacitors or COG, NP0 ceramic capacitors for the VCR divider and ISNS capacitor for low distortion
- Add necessary filtering capacitors on the BW pin to filter out the high spikes on the bias winding waveform. It is critical to filter out the high spikes because internally the signal is peak detected and then sampled at the low-side turn off edge.
- Keep necessary high voltage clearance and creepage.
- If 2 kV HBM ESD rating is needed on HV pin, it is acceptable to place a 100 pF capacitor from the HV pin to ground in order to pass up to 2 kV HBM ESD.

9.2 Layout Example

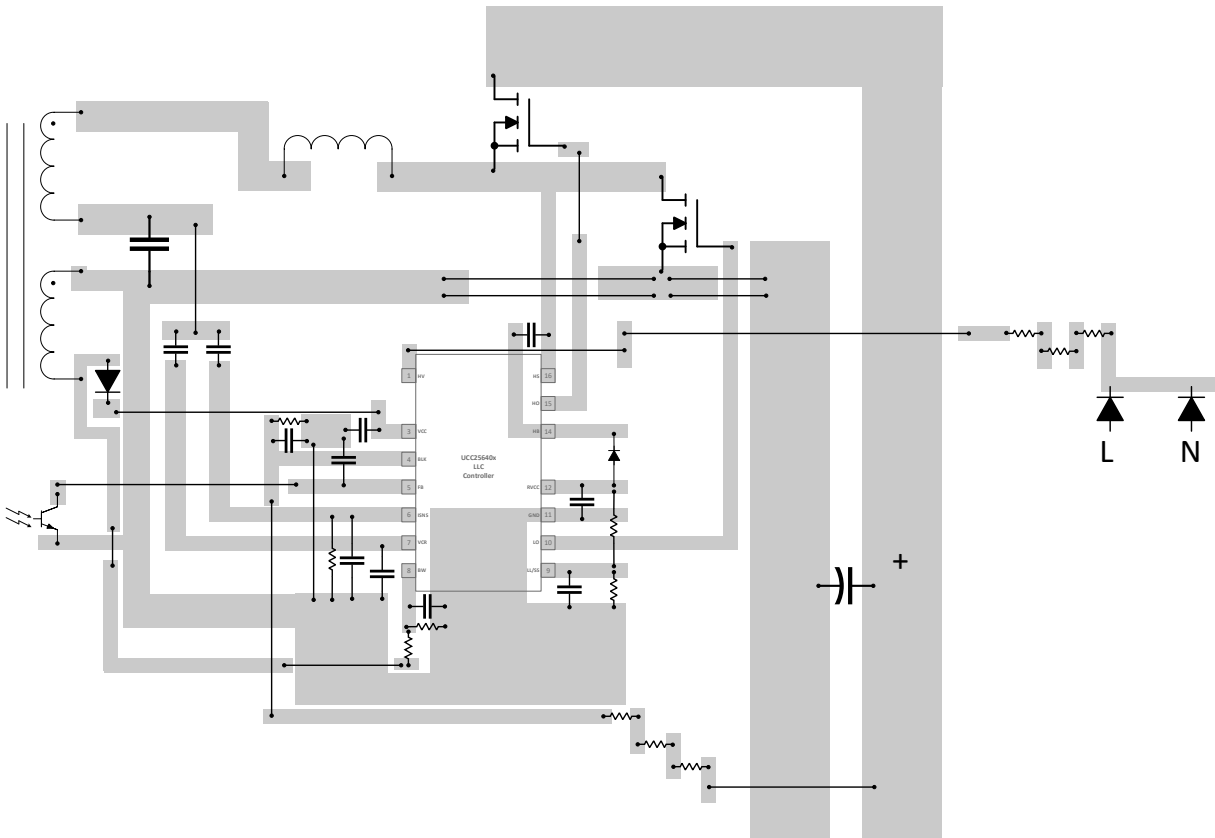

Figure 9-1. Layout Example for Single-Layer PCB

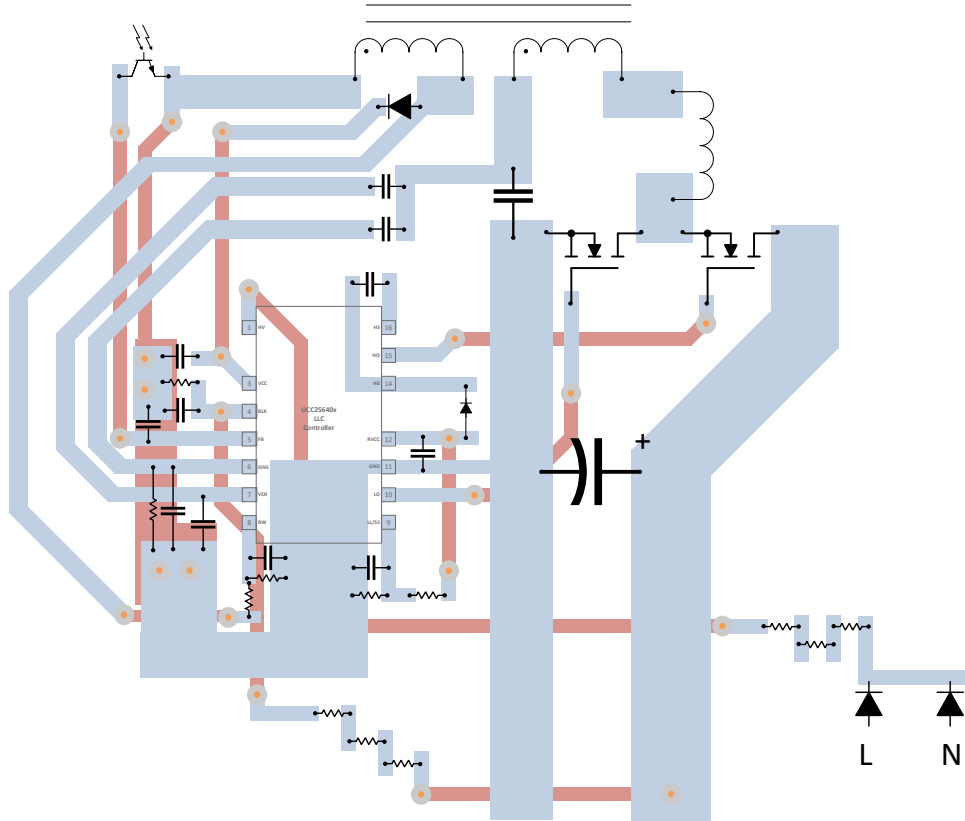

Figure 9-2. Layout Example for Double-Layer PCB

10 Device and Documentation Support

10.1 Documentation Support

10.1.1 Related Documentation

For related documentation see the following:

- Design Spreadsheet, [UCC25640x Design Calculator](#)
- User Guide, [Using UCC25640EVM-020](#)

10.2 Related Links

The table below lists quick access links. Categories include technical documents, support and community resources, tools and software, and quick access to order now.

Table 10-1. Related Links

PARTS	PRODUCT FOLDER	ORDER NOW	TECHNICAL DOCUMENTS	TOOLS & SOFTWARE	SUPPORT & COMMUNITY
UCC256402	Click here	Click here	Click here	Click here	Click here
UCC256403	Click here	Click here	Click here	Click here	Click here
UCC256404	Click here	Click here	Click here	Click here	Click here

10.3 Receiving Notification of Documentation Updates

To receive notification of documentation updates, navigate to the device product folder on ti.com. In the upper right corner, click on *Alert me* to register and receive a weekly digest of any product information that has changed. For change details, review the revision history included in any revised document.

10.4 Community Resources

10.5 Trademarks

All trademarks are the property of their respective owners.

Mechanical, Packaging, and Orderable Information

The following pages include mechanical, packaging, and orderable information. This information is the most current data available for the designated devices. This data is subject to change without notice and revision of this document. For browser-based versions of this data sheet, refer to the left-hand navigation.

PACKAGING INFORMATION

Orderable Device	Status (1)	Package Type	Package Drawing	Pins	Package Qty	Eco Plan (2)	Lead finish/ Ball material (6)	MSL Peak Temp (3)	Op Temp (°C)	Device Marking (4/5)	Samples
UCC256402ADDBR	ACTIVE	SOIC	DDB	14	2500	RoHS & Green	NIPDAU	Level-2-260C-1 YEAR	-40 to 125	UCC256402A	Samples
UCC256402ADDBT	ACTIVE	SOIC	DDB	14	250	RoHS & Green	NIPDAU	Level-2-260C-1 YEAR	-40 to 125	UCC256402A	Samples
UCC256402DDBR	ACTIVE	SOIC	DDB	14	2500	RoHS & Green	NIPDAU	Level-2-260C-1 YEAR	-40 to 125	UCC256402	Samples
UCC256402DDBT	ACTIVE	SOIC	DDB	14	250	RoHS & Green	NIPDAU	Level-2-260C-1 YEAR	-40 to 125	UCC256402	Samples
UCC256403ADDBR	ACTIVE	SOIC	DDB	14	2500	RoHS & Green	NIPDAU	Level-2-260C-1 YEAR	-40 to 125	UCC256403A	Samples
UCC256403DDBR	ACTIVE	SOIC	DDB	14	2500	RoHS & Green	NIPDAU	Level-2-260C-1 YEAR	-40 to 125	UCC256403	Samples
UCC256403DDBT	ACTIVE	SOIC	DDB	14	250	RoHS & Green	NIPDAU	Level-2-260C-1 YEAR	-40 to 125	UCC256403	Samples
UCC256404ADDBR	ACTIVE	SOIC	DDB	14	2500	RoHS & Green	NIPDAU	Level-2-260C-1 YEAR	-40 to 125	UCC256404A	Samples
UCC256404ADDBT	ACTIVE	SOIC	DDB	14	250	RoHS & Green	NIPDAU	Level-2-260C-1 YEAR	-40 to 125	UCC256404A	Samples
UCC256404BDDBR	ACTIVE	SOIC	DDB	14	2500	RoHS & Green	NIPDAU	Level-2-260C-1 YEAR	-40 to 125	UCC256404B	Samples
UCC256404DDBR	ACTIVE	SOIC	DDB	14	2500	RoHS & Green	NIPDAU	Level-2-260C-1 YEAR	-40 to 125	UCC256404	Samples
UCC256404DDBT	ACTIVE	SOIC	DDB	14	250	RoHS & Green	NIPDAU	Level-2-260C-1 YEAR	-40 to 125	UCC256404	Samples

(1) The marketing status values are defined as follows:

ACTIVE: Product device recommended for new designs.

LIFEBUY: TI has announced that the device will be discontinued, and a lifetime-buy period is in effect.

NRND: Not recommended for new designs. Device is in production to support existing customers, but TI does not recommend using this part in a new design.

PREVIEW: Device has been announced but is not in production. Samples may or may not be available.

OBSOLETE: TI has discontinued the production of the device.

(2) **RoHS:** TI defines "RoHS" to mean semiconductor products that are compliant with the current EU RoHS requirements for all 10 RoHS substances, including the requirement that RoHS substance do not exceed 0.1% by weight in homogeneous materials. Where designed to be soldered at high temperatures, "RoHS" products are suitable for use in specified lead-free processes. TI may reference these types of products as "Pb-Free".

RoHS Exempt: TI defines "RoHS Exempt" to mean products that contain lead but are compliant with EU RoHS pursuant to a specific EU RoHS exemption.

Green: TI defines "Green" to mean the content of Chlorine (Cl) and Bromine (Br) based flame retardants meet JS709B low halogen requirements of <=1000ppm threshold. Antimony trioxide based flame retardants must also meet the <=1000ppm threshold requirement.

- (3) MSL, Peak Temp. - The Moisture Sensitivity Level rating according to the JEDEC industry standard classifications, and peak solder temperature.
- (4) There may be additional marking, which relates to the logo, the lot trace code information, or the environmental category on the device.
- (5) Multiple Device Markings will be inside parentheses. Only one Device Marking contained in parentheses and separated by a "~" will appear on a device. If a line is indented then it is a continuation of the previous line and the two combined represent the entire Device Marking for that device.
- (6) Lead finish/Ball material - Orderable Devices may have multiple material finish options. Finish options are separated by a vertical ruled line. Lead finish/Ball material values may wrap to two lines if the finish value exceeds the maximum column width.

Important Information and Disclaimer:The information provided on this page represents TI's knowledge and belief as of the date that it is provided. TI bases its knowledge and belief on information provided by third parties, and makes no representation or warranty as to the accuracy of such information. Efforts are underway to better integrate information from third parties. TI has taken and continues to take reasonable steps to provide representative and accurate information but may not have conducted destructive testing or chemical analysis on incoming materials and chemicals. TI and TI suppliers consider certain information to be proprietary, and thus CAS numbers and other limited information may not be available for release.

In no event shall TI's liability arising out of such information exceed the total purchase price of the TI part(s) at issue in this document sold by TI to Customer on an annual basis.

DDB0014A



PACKAGE OUTLINE

SOIC - 1.75 mm max height

SOIC

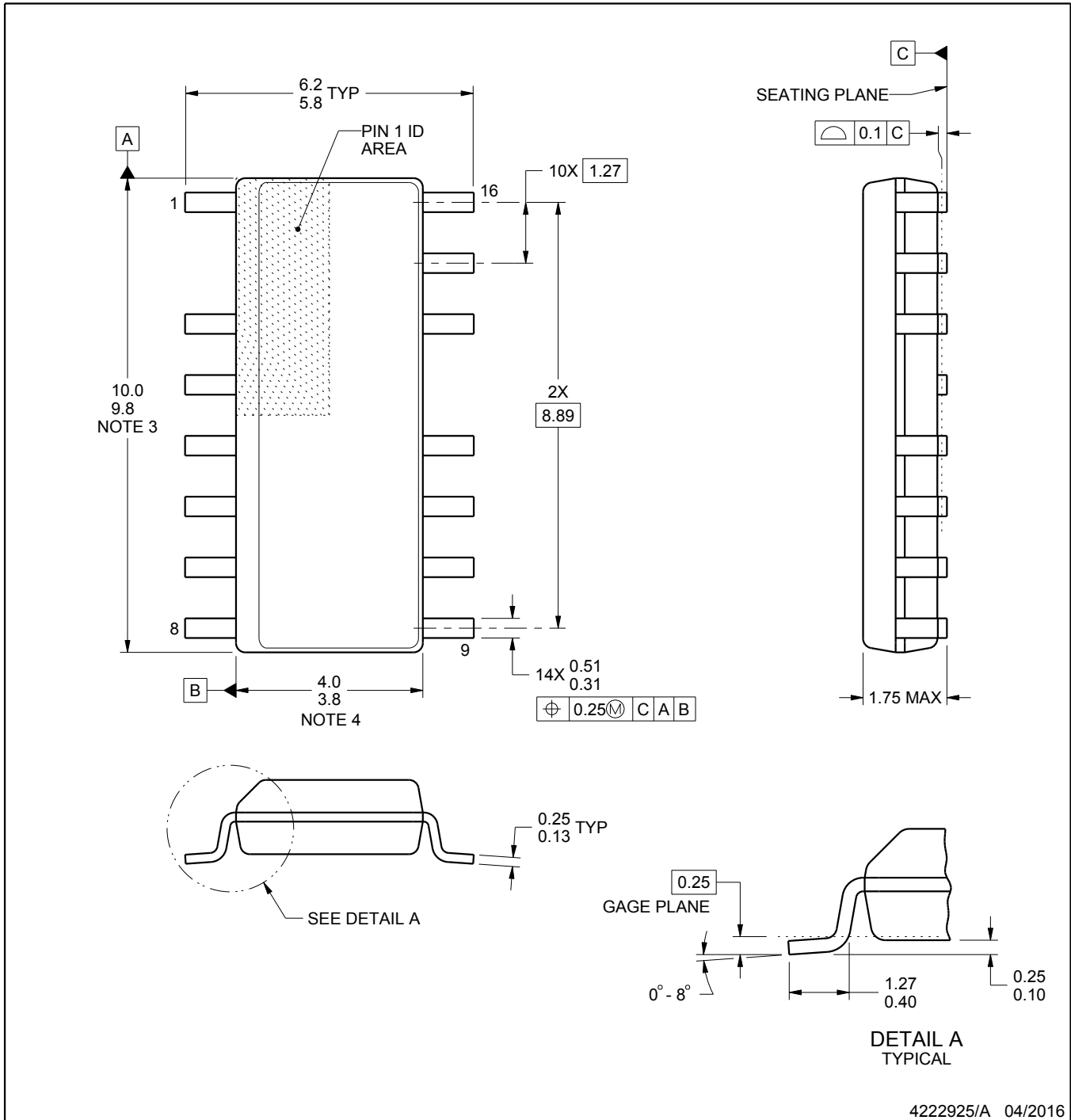

4222925/A 04/2016

NOTES:

- All linear dimensions are in millimeters. Dimensions in parenthesis are for reference only. Dimensioning and tolerancing per ASME Y14.5M.
- This drawing is subject to change without notice.
- This dimension does not include mold flash, protrusions, or gate burrs. Mold flash, protrusions, or gate burrs shall not exceed 0.15 mm per side.
- This dimension does not include interlead flash. Interlead flash shall not exceed 0.43 mm per side.
- Reference JEDEC registration MS-012, variation AC.

EXAMPLE BOARD LAYOUT

DDB0014A

SOIC - 1.75 mm max height

SOIC

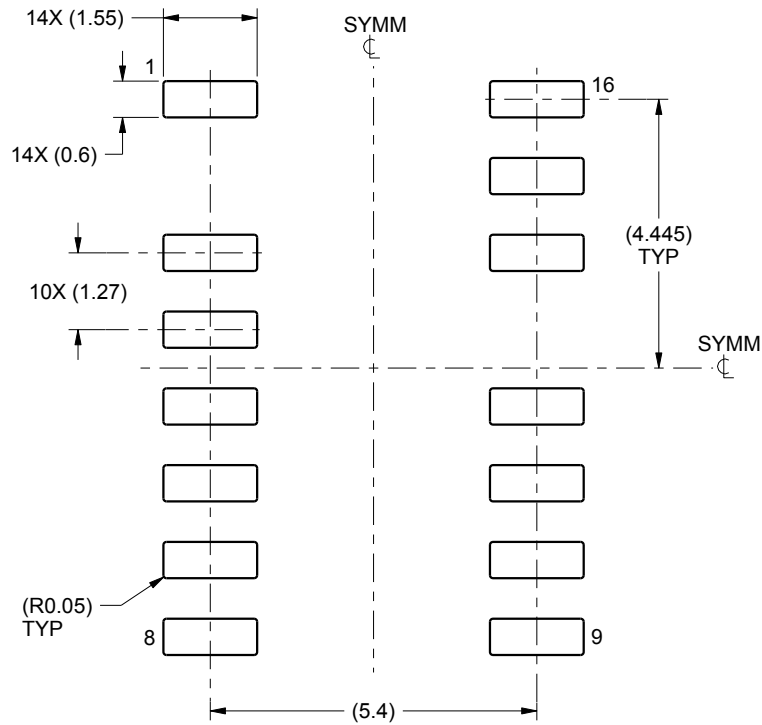

LAND PATTERN EXAMPLE
SCALE:8X

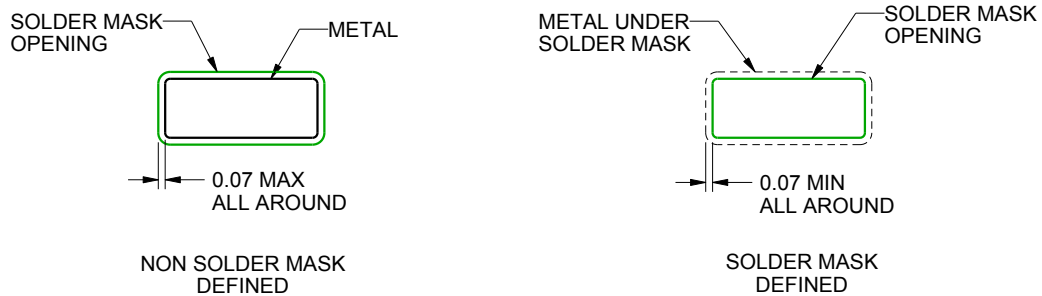

SOLDER MASK DETAILS

4222925/A 04/2016

NOTES: (continued)

- 6. Publication IPC-7351 may have alternate designs.
- 7. Solder mask tolerances between and around signal pads can vary based on board fabrication site.

EXAMPLE STENCIL DESIGN

DDB0014A

SOIC - 1.75 mm max height

SOIC

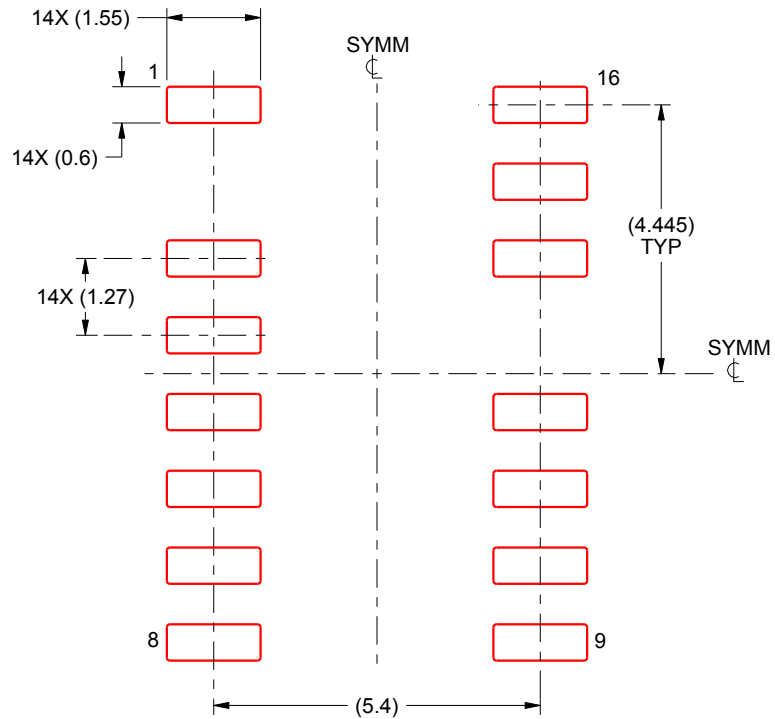

SOLDER PASTE EXAMPLE
BASED ON 0.125 mm THICK STENCIL
SCALE:8X

4222925/A 04/2016

NOTES: (continued)

8. Laser cutting apertures with trapezoidal walls and rounded corners may offer better paste release. IPC-7525 may have alternate design recommendations.
9. Board assembly site may have different recommendations for stencil design.

IMPORTANT NOTICE AND DISCLAIMER

TI PROVIDES TECHNICAL AND RELIABILITY DATA (INCLUDING DATASHEETS), DESIGN RESOURCES (INCLUDING REFERENCE DESIGNS), APPLICATION OR OTHER DESIGN ADVICE, WEB TOOLS, SAFETY INFORMATION, AND OTHER RESOURCES "AS IS" AND WITH ALL FAULTS, AND DISCLAIMS ALL WARRANTIES, EXPRESS AND IMPLIED, INCLUDING WITHOUT LIMITATION ANY IMPLIED WARRANTIES OF MERCHANTABILITY, FITNESS FOR A PARTICULAR PURPOSE OR NON-INFRINGEMENT OF THIRD PARTY INTELLECTUAL PROPERTY RIGHTS.

These resources are intended for skilled developers designing with TI products. You are solely responsible for (1) selecting the appropriate TI products for your application, (2) designing, validating and testing your application, and (3) ensuring your application meets applicable standards, and any other safety, security, or other requirements. These resources are subject to change without notice. TI grants you permission to use these resources only for development of an application that uses the TI products described in the resource. Other reproduction and display of these resources is prohibited. No license is granted to any other TI intellectual property right or to any third party intellectual property right. TI disclaims responsibility for, and you will fully indemnify TI and its representatives against, any claims, damages, costs, losses, and liabilities arising out of your use of these resources.

TI's products are provided subject to TI's Terms of Sale (<https://www.ti.com/legal/termsofsale.html>) or other applicable terms available either on [ti.com](https://www.ti.com) or provided in conjunction with such TI products. TI's provision of these resources does not expand or otherwise alter TI's applicable warranties or warranty disclaimers for TI products.

Mailing Address: Texas Instruments, Post Office Box 655303, Dallas, Texas 75265
Copyright © 2021, Texas Instruments Incorporated