

SN54ABTH16823, SN74ABTH16823 18-BIT BUS-INTERFACE FLIP-FLOPS WITH 3-STATE OUTPUTS

SCBS664B – APRIL 1996 – REVISED MAY 1997

- Members of the Texas Instruments *Widebus™* Family
- State-of-the-Art *EPIC-II B™* BiCMOS Design Significantly Reduces Power Dissipation
- ESD Protection Exceeds 2000 V Per MIL-STD-883, Method 3015; Exceeds 200 V Using Machine Model (C = 200 pF, R = 0)
- Typical V_{OLP} (Output Ground Bounce) < 1 V at $V_{CC} = 5$ V, $T_A = 25^\circ\text{C}$
- High-Impedance State During Power Up and Power Down
- Distributed V_{CC} and GND Pin Configuration Minimizes High-Speed Switching Noise
- Flow-Through Architecture Optimizes PCB Layout
- High-Drive Outputs ($-32\text{-mA } I_{OH}$, $64\text{-mA } I_{OL}$)
- Bus Hold on Data Inputs Eliminates the Need for External Pullup/Pulldown Resistors
- Package Options Include Plastic 300-mil Shrink Small-Outline (DL) and Thin Shrink Small-Outline (DGG) Packages and 380-mil Fine-Pitch Ceramic Flat (WD) Package Using 25-mil Center-to-Center Spacings

SN54ABTH16823 . . . WD PACKAGE
SN74ABTH16823 . . . DGG OR DL PACKAGE
(TOP VIEW)

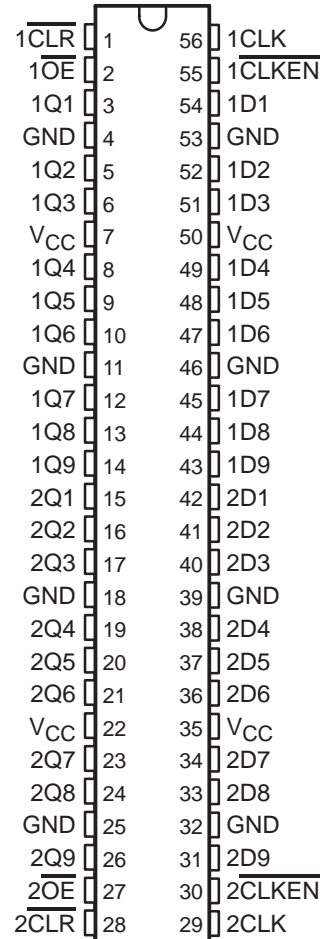

description

These 18-bit flip-flops feature 3-state outputs designed specifically for driving highly capacitive or relatively low-impedance loads. They are particularly suitable for implementing wider buffer registers, I/O ports, bidirectional bus drivers with parity, and working registers.

The 'ABTH16823 can be used as two 9-bit flip-flops or one 18-bit flip-flop. With the clock-enable ($\overline{\text{CLKEN}}$) input low, the D-type flip-flops enter data on the low-to-high transitions of the clock. Taking $\overline{\text{CLKEN}}$ high disables the clock buffer, latching the outputs. Taking the clear ($\overline{\text{CLR}}$) input low causes the Q outputs to go low independently of the clock.

A buffered output-enable ($\overline{\text{OE}}$) input can be used to place the nine outputs in either a normal logic state (high or low logic levels) or a high-impedance state. In the high-impedance state, the outputs neither load nor drive the bus lines significantly. The high-impedance state and increased drive provide the capability to drive bus lines without need for interface or pullup components.

$\overline{\text{OE}}$ does not affect the internal operation of the flip-flops. Old data can be retained or new data can be entered while the outputs are in the high-impedance state.



Please be aware that an important notice concerning availability, standard warranty, and use in critical applications of Texas Instruments semiconductor products and disclaimers thereto appears at the end of this data sheet.

Widebus and EPIC-II B are trademarks of Texas Instruments Incorporated.

PRODUCTION DATA information is current as of publication date. Products conform to specifications per the terms of Texas Instruments standard warranty. Production processing does not necessarily include testing of all parameters.

 **TEXAS
INSTRUMENTS**

POST OFFICE BOX 655303 • DALLAS, TEXAS 75265

Copyright © 1997, Texas Instruments Incorporated

SN54ABTH16823, SN74ABTH16823
18-BIT BUS-INTERFACE FLIP-FLOPS
WITH 3-STATE OUTPUTS

SCBS664B – APRIL 1996 – REVISED MAY 1997

description (continued)

When V_{CC} is between 0 and 2.1 V, the device is in the high-impedance state during power up or power down. However, to ensure the high-impedance state above 2.1 V, \overline{OE} should be tied to V_{CC} through a pullup resistor; the minimum value of the resistor is determined by the current-sinking capability of the driver.

Active bus-hold circuitry is provided to hold unused or floating data inputs at a valid logic level.

The SN54ABTH16823 is characterized for operation over the full military temperature range of -55°C to 125°C . The SN74ABTH16823 is characterized for operation from -40°C to 85°C .

FUNCTION TABLE
 (each 9-bit flip-flop)

INPUTS					OUTPUT Q
\overline{OE}	\overline{CLR}	\overline{CLKEN}	CLK	D	
L	L	X	X	X	L
L	H	L	↑	H	H
L	H	L	↑	L	L
L	H	L	L	X	Q_0
L	H	H	X	X	Q_0
H	X	X	X	X	Z



SN54ABTH16823, SN74ABTH16823 18-BIT BUS-INTERFACE FLIP-FLOPS WITH 3-STATE OUTPUTS

SCBS664B – APRIL 1996 – REVISED MAY 1997

logic symbol†

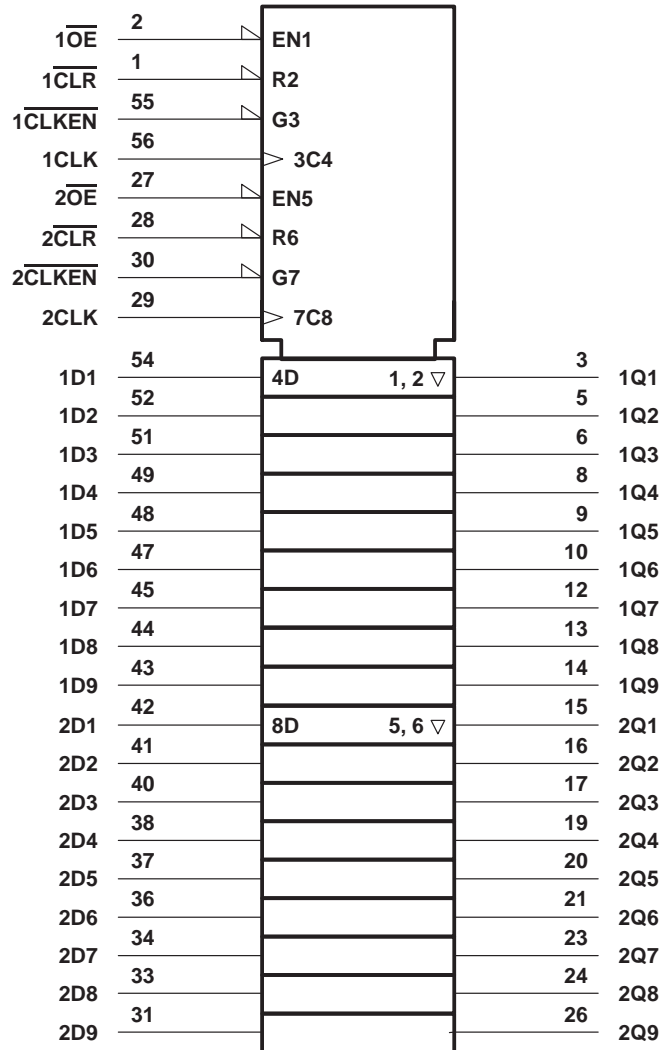

† This symbol is in accordance with ANSI/IEEE Std 91-1984 and IEC Publication 617-12.

SN54ABTH16823, SN74ABTH16823
18-BIT BUS-INTERFACE FLIP-FLOPS
WITH 3-STATE OUTPUTS

SCBS664B – APRIL 1996 – REVISED MAY 1997

logic diagram (positive logic)

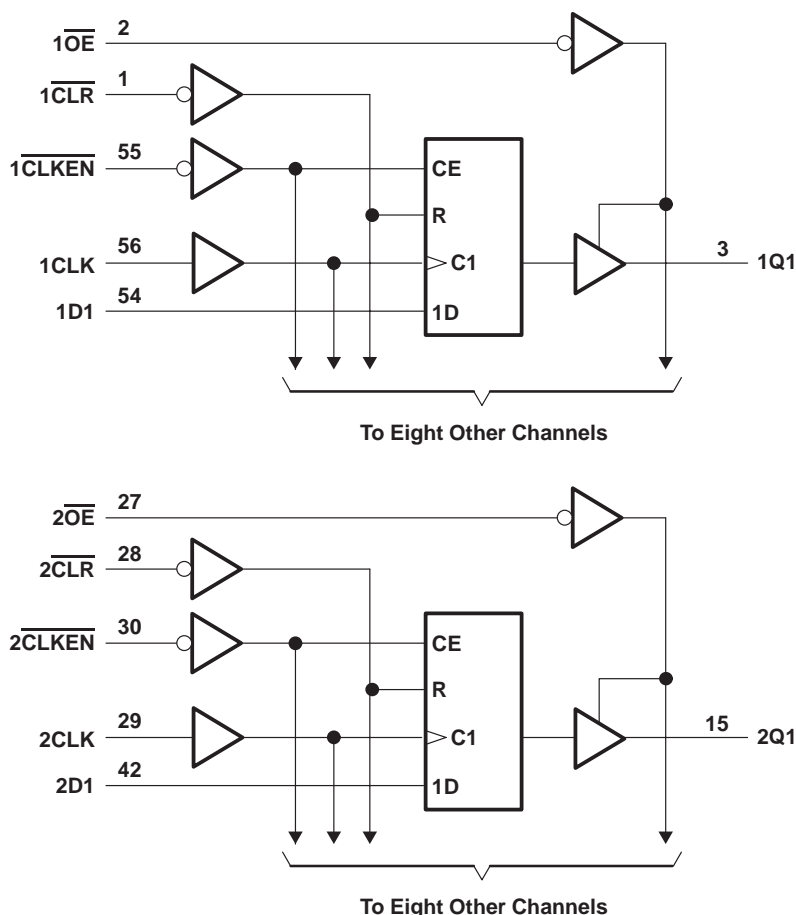

absolute maximum ratings over operating free-air temperature range (unless otherwise noted)†

Supply voltage range, V_{CC}	-0.5 V to 7 V
Input voltage range, V_I (see Note 1)	-0.5 V to 7 V
Voltage range applied to any output in the high or power-off state, V_O	-0.5 V to 5.5 V
Current into any output in the low state, I_O : SN54ABTH16823	96 mA
SN74ABTH16823	128 mA
Input clamp current, I_{IK} ($V_I < 0$)	-18 mA
Output clamp current, I_{OK} ($V_O < 0$)	-50 mA
Package thermal impedance, θ_{JA} (see Note 2): DGG package	81°C/W
DL package	74°C/W
Storage temperature range, T_{stg}	-65°C to 150°C

† Stresses beyond those listed under “absolute maximum ratings” may cause permanent damage to the device. These are stress ratings only, and functional operation of the device at these or any other conditions beyond those indicated under “recommended operating conditions” is not implied. Exposure to absolute-maximum-rated conditions for extended periods may affect device reliability.

- NOTES: 1. The input and output negative-voltage ratings may be exceeded if the input and output clamp-current ratings are observed.
 2. The package thermal impedance is calculated in accordance with EIA/JEDEC Std JESD51.



SN54ABTH16823, SN74ABTH16823
18-BIT BUS-INTERFACE FLIP-FLOPS
WITH 3-STATE OUTPUTS

SCBS664B – APRIL 1996 – REVISED MAY 1997

recommended operating conditions (see Note 3)

		SN54ABTH16823		SN74ABTH16823		UNIT
		MIN	MAX	MIN	MAX	
V _{CC}	Supply voltage	4.5	5.5	4.5	5.5	V
V _{IH}	High-level input voltage	2		2		V
V _{IL}	Low-level input voltage		0.8		0.8	V
V _I	Input voltage	0	V _{CC}	0	V _{CC}	V
I _{OH}	High-level output current		-24		-32	mA
I _{OL}	Low-level output current		48		64	mA
Δt/Δv	Input transition rise or fall rate	Outputs enabled		10	10	ns/V
Δt/ΔV _{CC}	Power-up ramp rate	200		200		μs/V
T _A	Operating free-air temperature	-55	125	-40	85	°C

NOTE 3: Unused inputs must be held high or low to prevent them from floating.

SN54ABTH16823, SN74ABTH16823
18-BIT BUS-INTERFACE FLIP-FLOPS
WITH 3-STATE OUTPUTS

SCBS664B – APRIL 1996 – REVISED MAY 1997

electrical characteristics over recommended operating free-air temperature range (unless otherwise noted)

PARAMETER	TEST CONDITIONS	T _A = 25°C			SN54ABTH16823		SN74ABTH16823		UNIT	
		MIN	TYP†	MAX	MIN	MAX	MIN	MAX		
V _{IK}	V _{CC} = 4.5 V, I _I = -18 mA			-1.2		-1.2		-1.2	V	
V _{OH}	V _{CC} = 4.5 V, I _{OH} = -3 mA		2.5		2.5		2.5		V	
	V _{CC} = 5 V, I _{OH} = -3 mA		3		3		3			
	V _{CC} = 4.5 V	I _{OH} = -24 mA	2		2					
		I _{OH} = -32 mA	2*				2			
V _{OL}	V _{CC} = 4.5 V	I _{OL} = 48 mA		0.55		0.55			V	
		I _{OL} = 64 mA		0.55*			0.55			
V _{hys}			100						mV	
I _I	V _{CC} = 0 to 5.5 V, V _I = V _{CC} or GND			±1		±1		±1	μA	
I _I (hold)	V _{CC} = -4.5 V	V _I = 0.8 V	100		100		100		μA	
		V _I = 2 V	-100		-100		-100			
I _{OZPU} ‡	V _{CC} = 0 to 2.1 V, V _O = 0.5 V to 2.7 V, $\overline{OE} = X$			±50		±50		±50	μA	
I _{OZPD} ‡	V _{CC} = 2.1 V to 0, V _O = 0.5 V to 2.7 V, $\overline{OE} = X$			±50		±50		±50	μA	
I _{OZH}	V _{CC} = 2.1 V to 5.5 V, V _O = 2.7 V, $\overline{OE} \geq 2$ V			10**		50		10	μA	
I _{OZL}	V _{CC} = 2.1 V to 5.5 V, V _O = 0.5 V, $\overline{OE} \geq 2$ V			-10**		-50		-10	μA	
I _{off}	V _{CC} = 0, V _I or V _O ≤ 4.5 V			±100				±100	μA	
I _{CEX}	Outputs high	V _{CC} = 5.5 V, V _O = 5.5 V		50		50		50	μA	
I _O §	V _{CC} = 5.5 V, V _O = 2.5 V		-50	-100	-200	-50	-200	-50	-200	mA
I _{CC}	Outputs high			0.5		0.5		0.5	mA	
	Outputs low	V _{CC} = 5.5 V, I _O = 0, V _I = V _{CC} or GND		80		80		80		
	Outputs disabled			0.5		0.5		0.5		
ΔI _{CC} ¶	V _{CC} = 5.5 V, One input at 3.4 V, Other inputs at V _{CC} or GND			1.5		1.5		1.5	mA	
C _i	V _I = 2.5 V or 0.5 V			4					pF	
C _o	V _O = 2.5 V or 0.5 V			8.5					pF	

* On products compliant to MIL-PRF-38535, this parameter does not apply.

** These limits apply only to the SN74ABTH16823.

† All typical values are at V_{CC} = 5 V.

‡ This parameter is characterized, but not production tested.

§ Not more than one output should be tested at a time, and the duration of the test should not exceed one second.

¶ This is the increase in supply current for each input that is at the specified TTL voltage level rather than V_{CC} or GND.



SN54ABTH16823, SN74ABTH16823
18-BIT BUS-INTERFACE FLIP-FLOPS
WITH 3-STATE OUTPUTS

SCBS664B – APRIL 1996 – REVISED MAY 1997

timing requirements over recommended ranges of supply voltage and operating free-air temperature (unless otherwise noted) (see Figure 1)

		$V_{CC} = 5\text{ V},$ $T_A = 25^\circ\text{C}$		SN54ABTH16823		SN74ABTH16823		UNIT
		MIN	MAX	MIN	MAX	MIN	MAX	
f_{clock}	Clock frequency	0	150	0	150	0	150	MHz
t_w	Pulse duration	$\overline{\text{CLR}}$ low	3.3	3.3	3.3	3.3		ns
		CLK high or low	3.3	3.3	3.3			
t_{su}	Setup time before CLK \uparrow	$\overline{\text{CLR}}$ inactive	1.6	2	1.6		ns	
		Data	1.7	1.7	1.7			
		$\overline{\text{CLKEN}}$ low	2.8	2.8	2.8			
t_h	Hold time after CLK \uparrow	Data	1.2	1.2	1.2		ns	
		$\overline{\text{CLKEN}}$ low	0.6	0.6	0.6			

switching characteristics over recommended ranges of supply voltage and operating free-air temperature, $C_L = 50\text{ pF}$ (unless otherwise noted) (see Figure 1)

PARAMETER	FROM (INPUT)	TO (OUTPUT)	SN54ABTH16823					UNIT
			$V_{CC} = 5\text{ V},$ $T_A = 25^\circ\text{C}$			MIN	MAX	
			MIN	TYP	MAX			
f_{max}			150			150	MHz	
t_{PLH}	CLK	Q	1.6	3.9	5.5	1.6	7.7	ns
t_{PHL}			2.1	3.9	5.4	2.1	6.4	
t_{PHL}	$\overline{\text{CLR}}$	Q	1.9	4.1	6	1.9	6.9	ns
t_{PZH}	$\overline{\text{OE}}$	Q	1	3.1	4.2	1	5.1	ns
t_{PZL}			1.5	3.5	4.6	1.5	5.7	
t_{PHZ}	$\overline{\text{OE}}$	Q	2.2	4.3	6	2.2	6.8	ns
t_{PLZ}			1.6	4.3	6.4	1.6	9.9	

switching characteristics over recommended ranges of supply voltage and operating free-air temperature, $C_L = 50\text{ pF}$ (unless otherwise noted) (see Figure 1)

PARAMETER	FROM (INPUT)	TO (OUTPUT)	SN74ABTH16823					UNIT
			$V_{CC} = 5\text{ V},$ $T_A = 25^\circ\text{C}$			MIN	MAX	
			MIN	TYP	MAX			
f_{max}			150			150	MHz	
t_{PLH}	CLK	Q	1.6	3.9	5.5	1.6	6.8	ns
t_{PHL}			2.1	3.9	5.4	2.1	6	
t_{PHL}	$\overline{\text{CLR}}$	Q	1.9	4.1	6	1.9	6.7	ns
t_{PZH}	$\overline{\text{OE}}$	Q	1	3.1	4.2	1	4.9	ns
t_{PZL}			1.5	3.5	4.6	1.5	5.5	
t_{PHZ}	$\overline{\text{OE}}$	Q	2.2	4.3	5.6	2.2	6.1	ns
t_{PLZ}			1.6	4.3	6.4	1.6	8.7	

SN54ABTH16823, SN74ABTH16823
18-BIT BUS-INTERFACE FLIP-FLOPS
WITH 3-STATE OUTPUTS

SCBS664B – APRIL 1996 – REVISED MAY 1997

PARAMETER MEASUREMENT INFORMATION

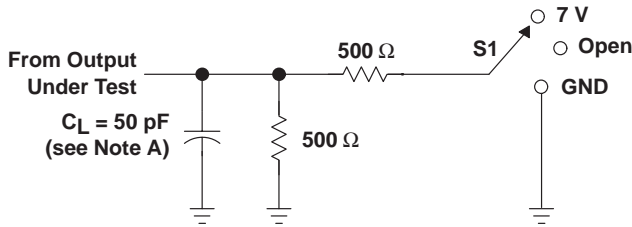

LOAD CIRCUIT

TEST	S1
t_{PLH}/t_{PHL}	Open
t_{PLZ}/t_{PZL}	7 V
t_{PHZ}/t_{PZH}	Open

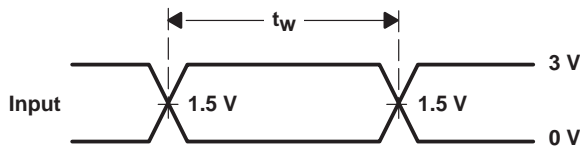

VOLTAGE WAVEFORMS
PULSE DURATION

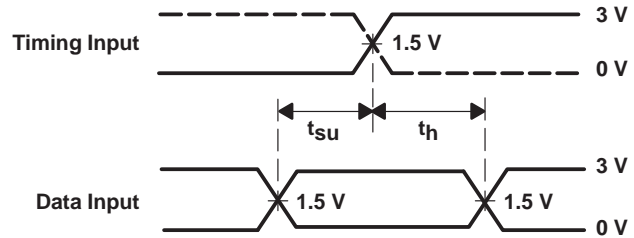

VOLTAGE WAVEFORMS
SETUP AND HOLD TIMES

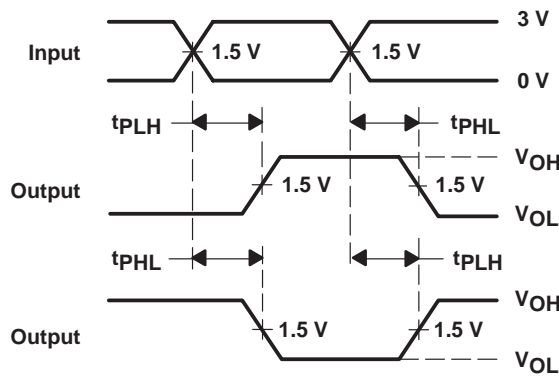

VOLTAGE WAVEFORMS
PROPAGATION DELAY TIMES
INVERTING AND NONINVERTING OUTPUTS

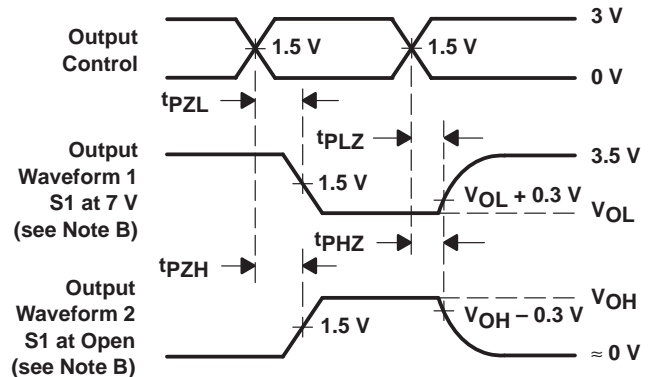

VOLTAGE WAVEFORMS
ENABLE AND DISABLE TIMES
LOW- AND HIGH-LEVEL ENABLING

- NOTES: A. C_L includes probe and jig capacitance.
 B. Waveform 1 is for an output with internal conditions such that the output is low except when disabled by the output control. Waveform 2 is for an output with internal conditions such that the output is high except when disabled by the output control.
 C. All input pulses are supplied by generators having the following characteristics: $PRR \leq 10 \text{ MHz}$, $Z_O = 50 \Omega$, $t_r \leq 2.5 \text{ ns}$, $t_f \leq 2.5 \text{ ns}$.
 D. The outputs are measured one at a time with one transition per measurement.

Figure 1. Load Circuit and Voltage Waveforms

PACKAGING INFORMATION

Orderable Device	Status (1)	Package Type	Package Drawing	Pins	Package Qty	Eco Plan (2)	Lead finish/ Ball material (6)	MSL Peak Temp (3)	Op Temp (°C)	Device Marking (4/5)	Samples
SN74ABTH16823DLR	ACTIVE	SSOP	DL	56	1000	RoHS & Green	NIPDAU	Level-1-260C-UNLIM	-40 to 85	ABTH16823	Samples

(1) The marketing status values are defined as follows:

ACTIVE: Product device recommended for new designs.

LIFEBUY: TI has announced that the device will be discontinued, and a lifetime-buy period is in effect.

NRND: Not recommended for new designs. Device is in production to support existing customers, but TI does not recommend using this part in a new design.

PREVIEW: Device has been announced but is not in production. Samples may or may not be available.

OBSELETE: TI has discontinued the production of the device.

(2) **RoHS:** TI defines "RoHS" to mean semiconductor products that are compliant with the current EU RoHS requirements for all 10 RoHS substances, including the requirement that RoHS substance do not exceed 0.1% by weight in homogeneous materials. Where designed to be soldered at high temperatures, "RoHS" products are suitable for use in specified lead-free processes. TI may reference these types of products as "Pb-Free".

RoHS Exempt: TI defines "RoHS Exempt" to mean products that contain lead but are compliant with EU RoHS pursuant to a specific EU RoHS exemption.

Green: TI defines "Green" to mean the content of Chlorine (Cl) and Bromine (Br) based flame retardants meet JS709B low halogen requirements of <=1000ppm threshold. Antimony trioxide based flame retardants must also meet the <=1000ppm threshold requirement.

(3) MSL, Peak Temp. - The Moisture Sensitivity Level rating according to the JEDEC industry standard classifications, and peak solder temperature.

(4) There may be additional marking, which relates to the logo, the lot trace code information, or the environmental category on the device.

(5) Multiple Device Markings will be inside parentheses. Only one Device Marking contained in parentheses and separated by a "-" will appear on a device. If a line is indented then it is a continuation of the previous line and the two combined represent the entire Device Marking for that device.

(6) Lead finish/Ball material - Orderable Devices may have multiple material finish options. Finish options are separated by a vertical ruled line. Lead finish/Ball material values may wrap to two lines if the finish value exceeds the maximum column width.

Important Information and Disclaimer:The information provided on this page represents TI's knowledge and belief as of the date that it is provided. TI bases its knowledge and belief on information provided by third parties, and makes no representation or warranty as to the accuracy of such information. Efforts are underway to better integrate information from third parties. TI has taken and continues to take reasonable steps to provide representative and accurate information but may not have conducted destructive testing or chemical analysis on incoming materials and chemicals. TI and TI suppliers consider certain information to be proprietary, and thus CAS numbers and other limited information may not be available for release.

In no event shall TI's liability arising out of such information exceed the total purchase price of the TI part(s) at issue in this document sold by TI to Customer on an annual basis.

TAPE AND REEL INFORMATION

REEL DIMENSIONS

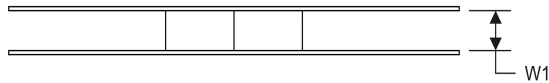
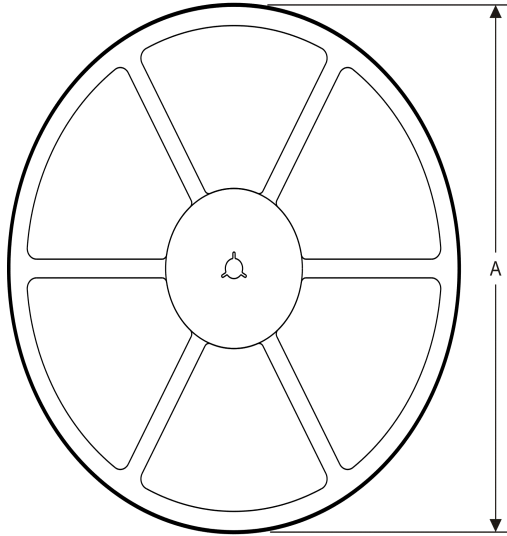

TAPE DIMENSIONS

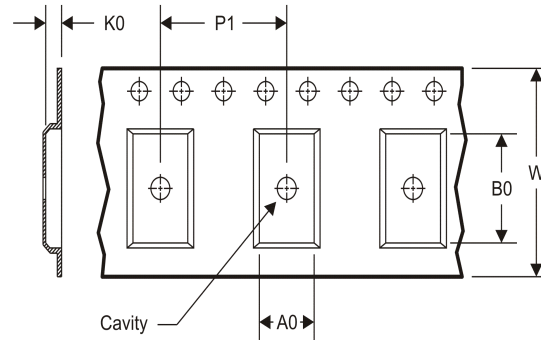

A0	Dimension designed to accommodate the component width
B0	Dimension designed to accommodate the component length
K0	Dimension designed to accommodate the component thickness
W	Overall width of the carrier tape
P1	Pitch between successive cavity centers

TAPE AND REEL INFORMATION

*All dimensions are nominal

Device	Package Type	Package Drawing	Pins	SPQ	Reel Diameter (mm)	Reel Width W1 (mm)	A0 (mm)	B0 (mm)	K0 (mm)	P1 (mm)	W (mm)	Pin1 Quadrant
SN74ABTH16823DLR	SSOP	DL	56	1000	330.0	32.4	11.35	18.67	3.1	16.0	32.0	Q1

TAPE AND REEL BOX DIMENSIONS



*All dimensions are nominal

Device	Package Type	Package Drawing	Pins	SPQ	Length (mm)	Width (mm)	Height (mm)
SN74ABTH16823DLR	SSOP	DL	56	1000	367.0	367.0	55.0

MECHANICAL DATA

DL (R-PDSO-G56)

PLASTIC SMALL-OUTLINE PACKAGE

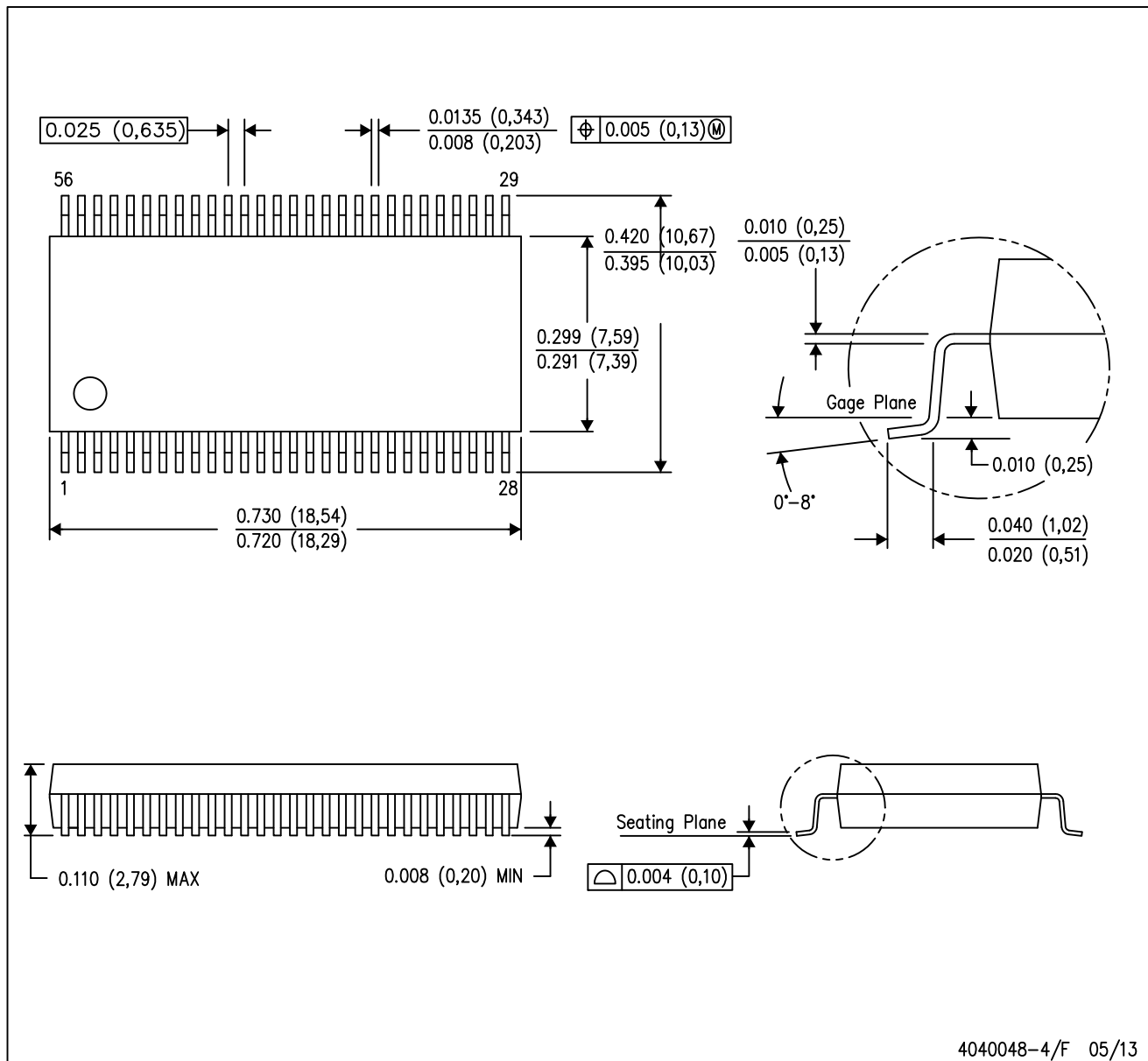

- NOTES:
- All linear dimensions are in inches (millimeters).
 - This drawing is subject to change without notice.
 - Body dimensions do not include mold flash or protrusion not to exceed 0.006 (0,15).
 - Falls within JEDEC MO-118

PowerPAD is a trademark of Texas Instruments.

IMPORTANT NOTICE AND DISCLAIMER

TI PROVIDES TECHNICAL AND RELIABILITY DATA (INCLUDING DATASHEETS), DESIGN RESOURCES (INCLUDING REFERENCE DESIGNS), APPLICATION OR OTHER DESIGN ADVICE, WEB TOOLS, SAFETY INFORMATION, AND OTHER RESOURCES "AS IS" AND WITH ALL FAULTS, AND DISCLAIMS ALL WARRANTIES, EXPRESS AND IMPLIED, INCLUDING WITHOUT LIMITATION ANY IMPLIED WARRANTIES OF MERCHANTABILITY, FITNESS FOR A PARTICULAR PURPOSE OR NON-INFRINGEMENT OF THIRD PARTY INTELLECTUAL PROPERTY RIGHTS.

These resources are intended for skilled developers designing with TI products. You are solely responsible for (1) selecting the appropriate TI products for your application, (2) designing, validating and testing your application, and (3) ensuring your application meets applicable standards, and any other safety, security, or other requirements. These resources are subject to change without notice. TI grants you permission to use these resources only for development of an application that uses the TI products described in the resource. Other reproduction and display of these resources is prohibited. No license is granted to any other TI intellectual property right or to any third party intellectual property right. TI disclaims responsibility for, and you will fully indemnify TI and its representatives against, any claims, damages, costs, losses, and liabilities arising out of your use of these resources.

TI's products are provided subject to TI's Terms of Sale (www.ti.com/legal/termsofsale.html) or other applicable terms available either on ti.com or provided in conjunction with such TI products. TI's provision of these resources does not expand or otherwise alter TI's applicable warranties or warranty disclaimers for TI products.

Mailing Address: Texas Instruments, Post Office Box 655303, Dallas, Texas 75265
Copyright © 2020, Texas Instruments Incorporated