

## LM136-2.5-N, LM236-2.5-N, LM336-2.5-NV Reference Diode

Check for Samples: [LM136-2.5-N](#)

### FEATURES

- **Low Temperature Coefficient**
- **Wide Operating Current of 400  $\mu$ A to 10 mA**
- **0.2 $\Omega$  Dynamic Impedance**
- **$\pm$ 1% Initial Tolerance Available**
- **Specified Temperature Stability**
- **Easily Trimmed for Minimum Temperature Drift**
- **Fast Turn-On**

### DESCRIPTION

The LM136-2.5-N/LM236-2.5-N and LM336-2.5-N integrated circuits are precision 2.5V shunt regulator diodes. These monolithic IC voltage references operate as a low-temperature-coefficient 2.5V zener with 0.2 $\Omega$  dynamic impedance. A third terminal on the LM136-2.5-N allows the reference voltage and temperature coefficient to be trimmed easily.

The LM136-2.5-N series is useful as a precision 2.5V low voltage reference for digital voltmeters, power supplies or op amp circuitry. The 2.5V make it convenient to obtain a stable reference from 5V logic supplies. Further, since the LM136-2.5-N operates as a shunt regulator, it can be used as either a positive or negative voltage reference.

The LM136-2.5-N is rated for operation over  $-55^{\circ}\text{C}$  to  $+125^{\circ}\text{C}$  while the LM236-2.5-N is rated over a  $-25^{\circ}\text{C}$  to  $+85^{\circ}\text{C}$  temperature range.

The LM336-2.5-N is rated for operation over a  $0^{\circ}\text{C}$  to  $+70^{\circ}\text{C}$  temperature range. See the connection diagrams for available packages.

### Connection Diagram

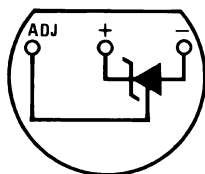
**TO-92 Plastic Package**

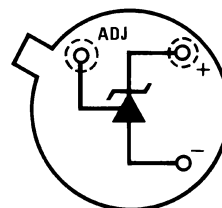
**Figure 1. Bottom View**  
See Package Number LP

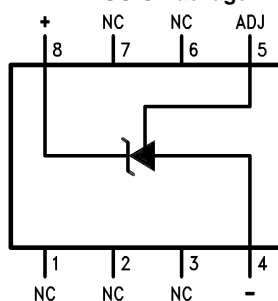
**TO Metal Can Package**

**Figure 2. Bottom View**  
See Package Number NDV

**SOIC Package**

**Figure 3. Top View**  
See Package Number D

Please be aware that an important notice concerning availability, standard warranty, and use in critical applications of Texas Instruments semiconductor products and disclaimers thereto appears at the end of this data sheet.

All trademarks are the property of their respective owners.

Typical Applications

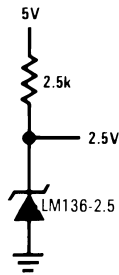
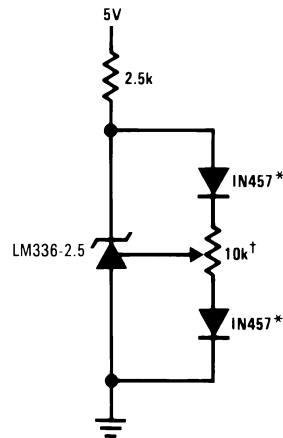

Figure 4. 2.5V Reference



†Adjust to 2.490V

\*Any silicon signal diode

Figure 5. 2.5V Reference with Minimum Temperature Coefficient

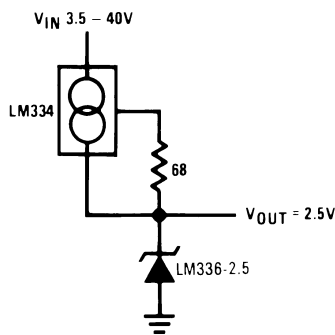

Figure 6. Wide Input Range Reference



These devices have limited built-in ESD protection. The leads should be shorted together or the device placed in conductive foam during storage or handling to prevent electrostatic damage to the MOS gates.

### Absolute Maximum Ratings<sup>(1)(2)</sup>

Reverse Current		15 mA	
Forward Current		10 mA	
Storage Temperature		-60°C to +150°C	
Operating Temperature Range <sup>(3)</sup>	LM136	-55°C to +150°C	
	LM236	-25°C to +85°C	
	LM336	0°C to +70°C	
Soldering Information	TO-92 Package (10 sec.)	260°C	
	TO Package (10 sec.)	300°C	
	SOIC Package	Vapor Phase (60 sec.)	215°C
		Infrared (15 sec.)	220°C

- (1) Absolute Maximum Ratings indicate limits beyond which damage to the device may occur. Electrical specifications do not apply when operating the device beyond its specified operating conditions.
- (2) If Military/Aerospace specified devices are required, please contact the Texas Instruments Sales Office/Distributors for availability and specifications.
- (3) For elevated temperature operation,  $T_j$  max is:
 

LM136	150°C
LM236	125°C
LM336	100°C

Thermal Resistance	TO-92	TO	SOIC
$\theta_{ja}$ (Junction to Ambient)	180°C/W (0.4" leads)	440°C/W	165°C/W
	170°C/W (0.125" lead)		
$\theta_{jc}$ (Junction to Case)	n/a	80°C/W	n/a

**Electrical Characteristics** <sup>(1)</sup>

Parameter	Conditions		LM136A-2.5-N/ LM236A-2.5-N LM136-2.5-N/ LM236-2.5-N			LM336B-2.5-N LM336-2.5-N			Units
			Min	Typ	Max	Min	Typ	Max	
Reverse Breakdown Voltage	$T_A=25^\circ\text{C}$ , $I_R=1\text{ mA}$	LM136, LM236, LM336	2.440	2.490	2.540	2.390	2.490	2.590	V
		LM136A, LM236A, LM336B	2.465	2.490	2.515	2.440	2.490	2.540	V
Reverse Breakdown Change With Current	$T_A=25^\circ\text{C}$ , $400\ \mu\text{A}\leq I_R\leq 10\text{ mA}$			2.6	6		2.6	10	mV
Reverse Dynamic Impedance	$T_A=25^\circ\text{C}$ , $I_R=1\text{ mA}$ , $f = 100\text{ Hz}$			0.2	0.6		0.2	1	$\Omega$
Temperature Stability <sup>(2)</sup>	$V_R$ Adjusted to 2.490V $I_R=1\text{ mA}$ <a href="#">Figure 15</a>	$0^\circ\text{C}\leq T_A\leq 70^\circ\text{C}$ (LM336)					1.8	6	mV
		$-25^\circ\text{C}\leq T_A\leq +85^\circ\text{C}$ (LM236H, LM236Z)		3.5	9				mV
		$-25^\circ\text{C}\leq T_A\leq +85^\circ\text{C}$ (LM236M)		7.5	18				mV
		$-55^\circ\text{C}\leq T_A\leq +125^\circ\text{C}$ (LM136)		12	18				mV
Reverse Breakdown Change With Current	$400\ \mu\text{A}\leq I_R\leq 10\text{ mA}$		3	10		3	12	mV	
Reverse Dynamic Impedance	$I_R=1\text{ mA}$		0.4	1		0.4	1.4	$\Omega$	
Long Term Stability	$T_A=25^\circ\text{C}\pm 0.1^\circ\text{C}$ , $I_R=1\text{ mA}$ , $t = 1000\text{ hrs}$		20			20		ppm	

- (1) Unless otherwise specified, the LM136-2.5-N is specified from  $-55^\circ\text{C}\leq T_A\leq +125^\circ\text{C}$ , the LM236-2.5-N from  $-25^\circ\text{C}\leq T_A\leq +85^\circ\text{C}$  and the LM336-2.5-N from  $0^\circ\text{C}\leq T_A\leq +70^\circ\text{C}$ .
- (2) Temperature stability for the LM336 and LM236 family is specified by design. Design limits are ensured (but not 100% production tested) over the indicated temperature and supply voltage ranges. These limits are not used to calculate outgoing quality levels. Stability is defined as the maximum change in  $V_{\text{ref}}$  from  $25^\circ\text{C}$  to  $T_A$  (min) or  $T_A$  (max).

Typical Performance Characteristics

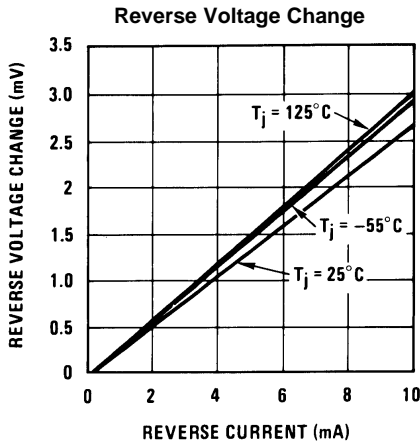

Figure 7.

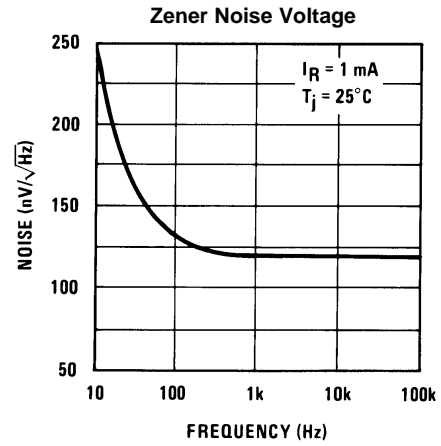

Figure 8.

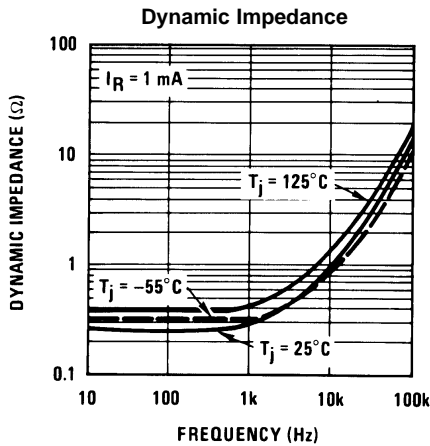

Figure 9.

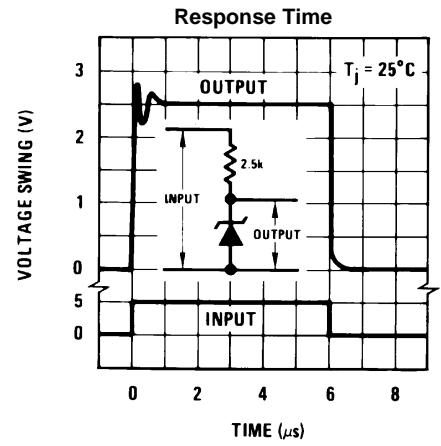

Figure 10.

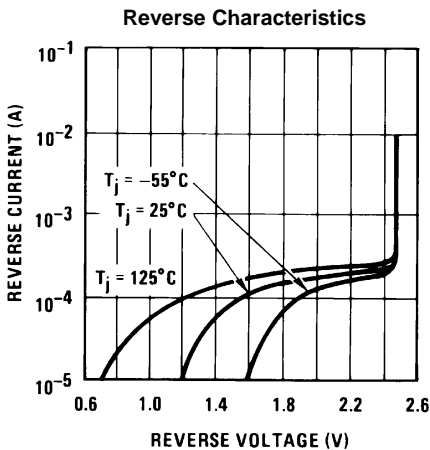

Figure 11.

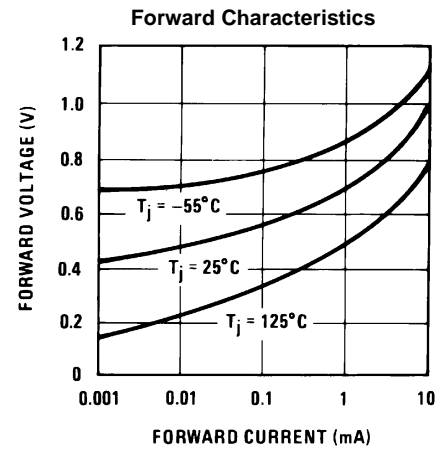
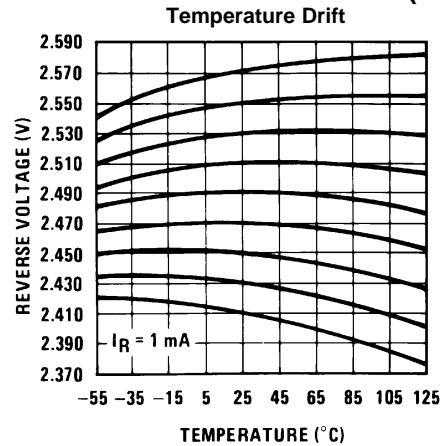

Figure 12.

## Typical Performance Characteristics (continued)



## APPLICATION HINTS

The LM136 series voltage references are much easier to use than ordinary zener diodes. Their low impedance and wide operating current range simplify biasing in almost any circuit. Further, either the breakdown voltage or the temperature coefficient can be adjusted to optimize circuit performance.

Figure 14 shows an LM136 with a 10k potentiometer for adjusting the reverse breakdown voltage. With the addition of R1 the breakdown voltage can be adjusted without affecting the temperature coefficient of the device. The adjustment range is usually sufficient to adjust for both the initial device tolerance and inaccuracies in buffer circuitry.

If minimum temperature coefficient is desired, two diodes can be added in series with the adjustment potentiometer as shown in Figure 15. When the device is adjusted to 2.490V the temperature coefficient is minimized. Almost any silicon signal diode can be used for this purpose such as a 1N914, 1N4148 or a 1N457. For proper temperature compensation the diodes should be in the same thermal environment as the LM136. It is usually sufficient to mount the diodes near the LM136 on the printed circuit board. The absolute resistance of R1 is not critical and any value from 2k to 20k will work.

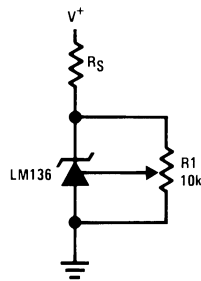

**Figure 14. LM136 With Pot for Adjustment of Breakdown Voltage**  
(Trim Range =  $\pm 120$  mV typical)

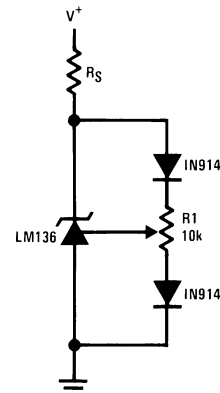

**Figure 15. Temperature Coefficient Adjustment**  
(Trim Range =  $\pm 70$  mV typical)

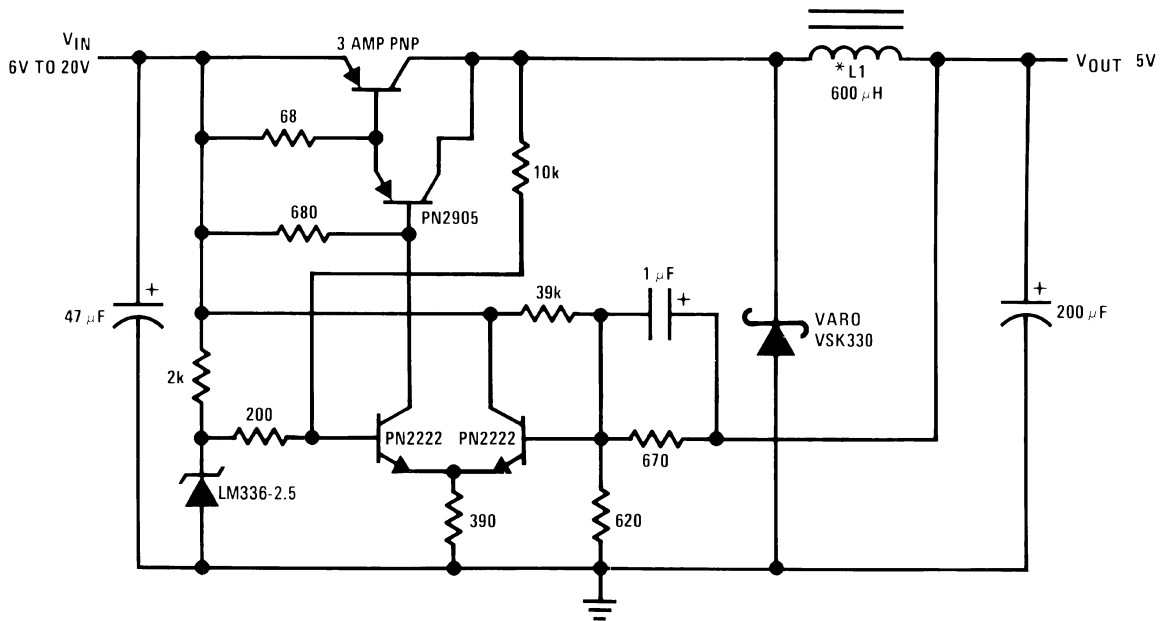

<sup>†</sup>L1 60 turns #16 wire on Arnold Core A-254168-2  
<sup>†</sup>Efficiency ≈ 80%

Figure 16. Low Cost 2 Amp Switching Regulator<sup>†</sup>

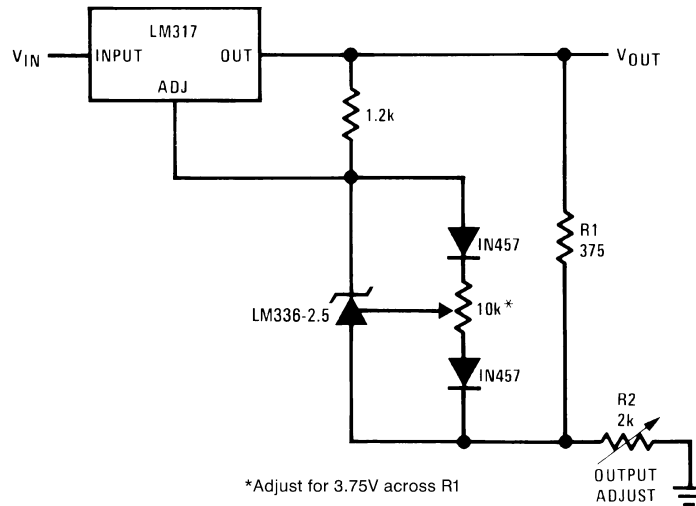

Figure 17. Precision Power Regulator with Low Temperature Coefficient

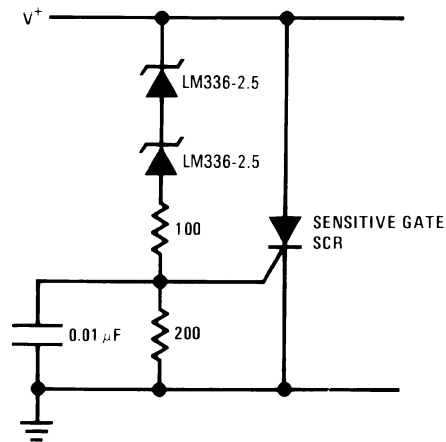
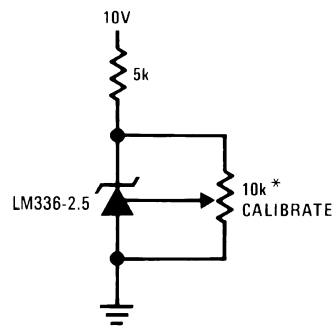

Figure 18. 5V Crowbar



\*Does not affect temperature coefficient

Figure 19. Trimmed 2.5V Reference with Temperature Coefficient Independent of Breakdown Voltage

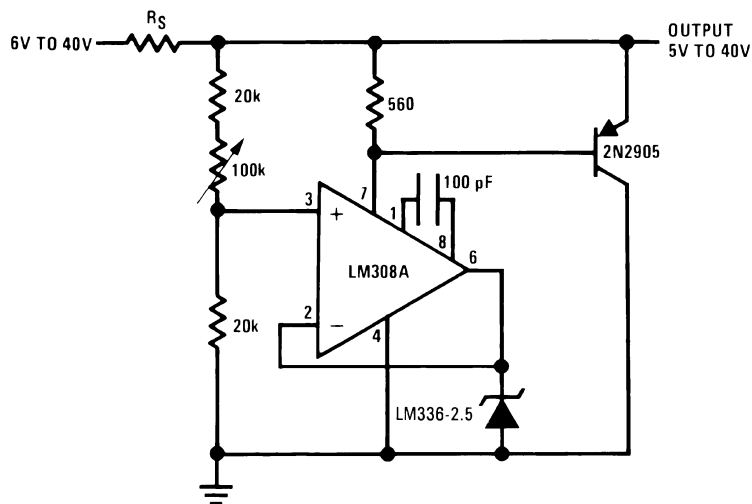

Figure 20. Adjustable Shunt Regulator

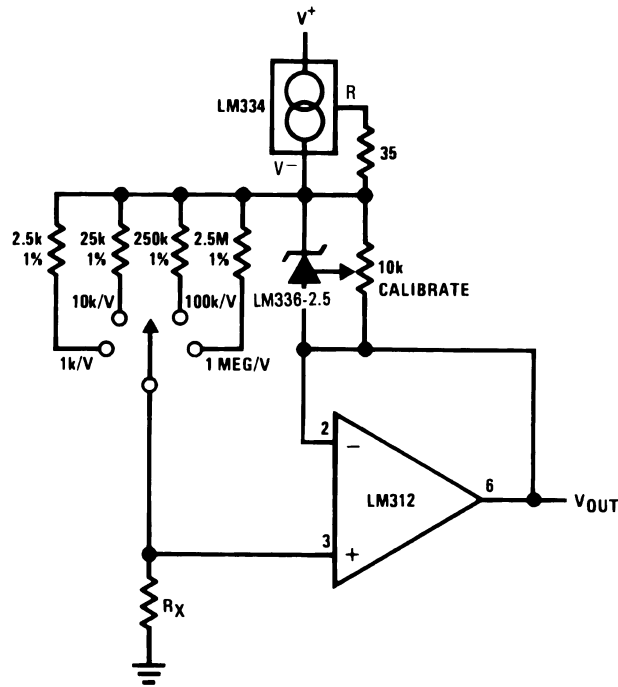

Figure 21. Linear Ohmmeter

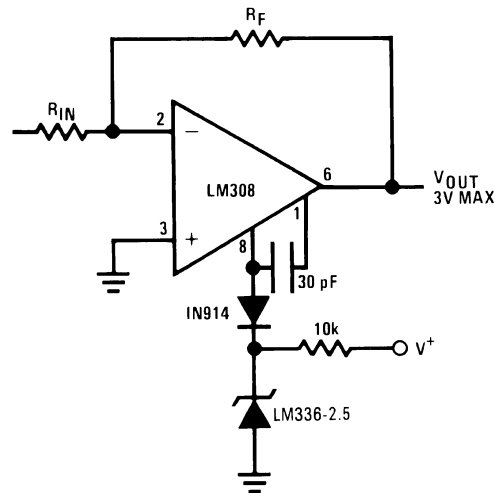

Figure 22. Op Amp with Output Clamped

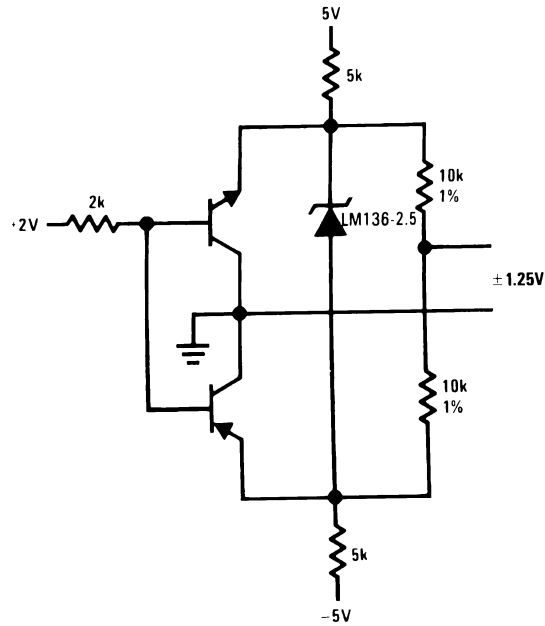

Figure 23. Bipolar Output Reference

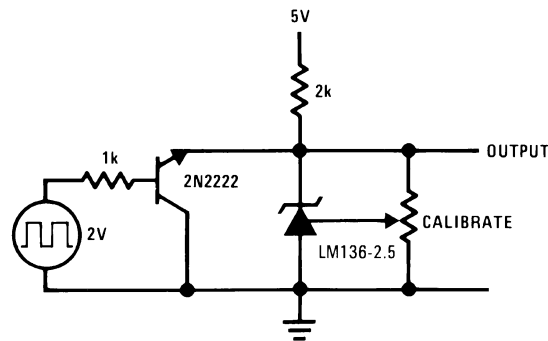

Figure 24. 2.5V Square Wave Calibrator

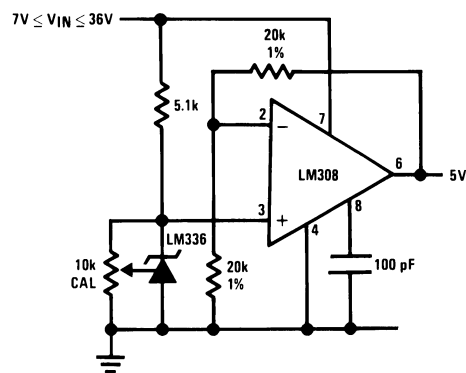

Figure 25. 5V Buffered Reference

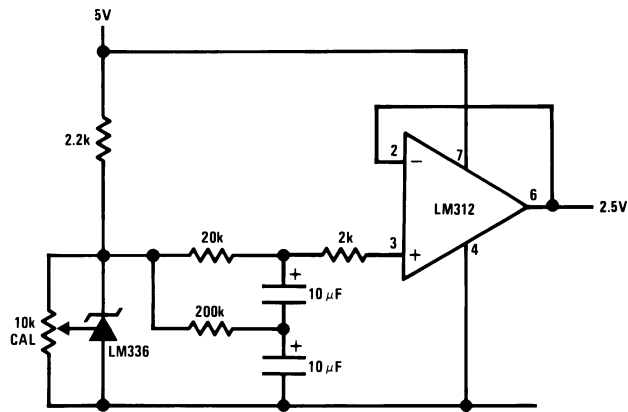
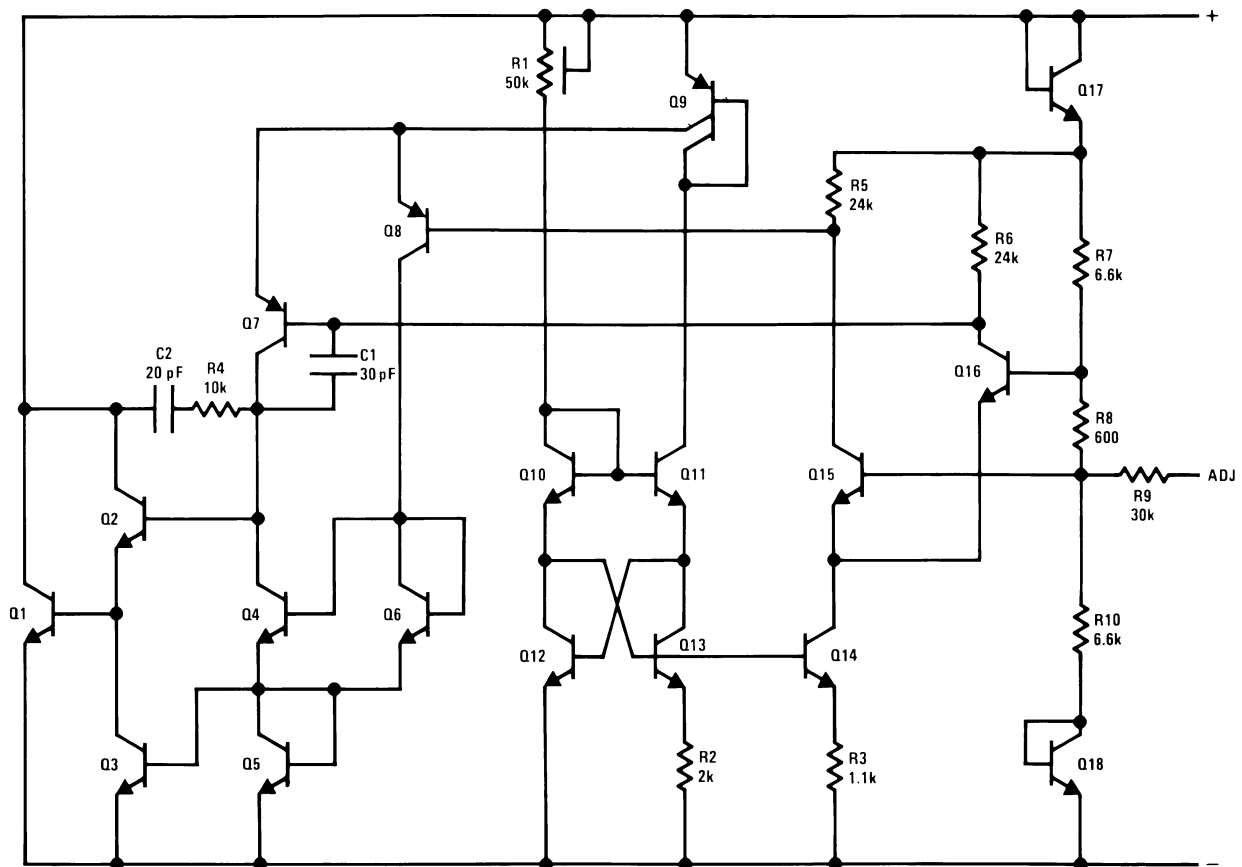

Figure 26. Low Noise Buffered Reference

Schematic Diagram



## REVISION HISTORY

Changes from Revision E (April 2013) to Revision F	Page
• Changed layout of National Data Sheet to TI format .....	11

**PACKAGING INFORMATION**

Orderable Device	Status (1)	Package Type	Package Drawing	Pins	Package Qty	Eco Plan (2)	Lead finish/ Ball material (6)	MSL Peak Temp (3)	Op Temp (°C)	Device Marking (4/5)	Samples
LM136AH-2.5	ACTIVE	TO	NDV	3	1000	Non-RoHS & Non-Green	Call TI	Call TI	-40 to 125	( LM136AH2.5, LM136AH2.5)	<a href="#">Samples</a>
LM136AH-2.5/NOPB	ACTIVE	TO	NDV	3	1000	RoHS & Green	Call TI	Level-1-NA-UNLIM	-40 to 125	( LM136AH2.5, LM136AH2.5)	<a href="#">Samples</a>
LM136H-2.5	ACTIVE	TO	NDV	3	1000	Non-RoHS & Non-Green	Call TI	Call TI	-55 to 125	( LM136H2.5, LM136H2.5)	<a href="#">Samples</a>
LM136H-2.5/NOPB	ACTIVE	TO	NDV	3	1000	RoHS & Green	Call TI	Level-1-NA-UNLIM	-55 to 125	( LM136H2.5, LM136H2.5)	<a href="#">Samples</a>
LM236H-2.5	ACTIVE	TO	NDV	3	1000	Non-RoHS & Non-Green	Call TI	Call TI	-25 to 85	( LM236H2.5, LM236H2.5)	<a href="#">Samples</a>
LM236H-2.5/NOPB	ACTIVE	TO	NDV	3	1000	RoHS & Green	Call TI	Level-1-NA-UNLIM	-25 to 85	( LM236H2.5, LM236H2.5)	<a href="#">Samples</a>

(1) The marketing status values are defined as follows:

**ACTIVE:** Product device recommended for new designs.

**LIFEBUY:** TI has announced that the device will be discontinued, and a lifetime-buy period is in effect.

**NRND:** Not recommended for new designs. Device is in production to support existing customers, but TI does not recommend using this part in a new design.

**PREVIEW:** Device has been announced but is not in production. Samples may or may not be available.

**OBSELETE:** TI has discontinued the production of the device.

(2) **RoHS:** TI defines "RoHS" to mean semiconductor products that are compliant with the current EU RoHS requirements for all 10 RoHS substances, including the requirement that RoHS substance do not exceed 0.1% by weight in homogeneous materials. Where designed to be soldered at high temperatures, "RoHS" products are suitable for use in specified lead-free processes. TI may reference these types of products as "Pb-Free".

**RoHS Exempt:** TI defines "RoHS Exempt" to mean products that contain lead but are compliant with EU RoHS pursuant to a specific EU RoHS exemption.

**Green:** TI defines "Green" to mean the content of Chlorine (Cl) and Bromine (Br) based flame retardants meet JS709B low halogen requirements of <=1000ppm threshold. Antimony trioxide based flame retardants must also meet the <=1000ppm threshold requirement.

(3) MSL, Peak Temp. - The Moisture Sensitivity Level rating according to the JEDEC industry standard classifications, and peak solder temperature.

(4) There may be additional marking, which relates to the logo, the lot trace code information, or the environmental category on the device.

(5) Multiple Device Markings will be inside parentheses. Only one Device Marking contained in parentheses and separated by a "-" will appear on a device. If a line is indented then it is a continuation of the previous line and the two combined represent the entire Device Marking for that device.

<sup>(6)</sup> Lead finish/Ball material - Orderable Devices may have multiple material finish options. Finish options are separated by a vertical ruled line. Lead finish/Ball material values may wrap to two lines if the finish value exceeds the maximum column width.

**Important Information and Disclaimer:**The information provided on this page represents TI's knowledge and belief as of the date that it is provided. TI bases its knowledge and belief on information provided by third parties, and makes no representation or warranty as to the accuracy of such information. Efforts are underway to better integrate information from third parties. TI has taken and continues to take reasonable steps to provide representative and accurate information but may not have conducted destructive testing or chemical analysis on incoming materials and chemicals. TI and TI suppliers consider certain information to be proprietary, and thus CAS numbers and other limited information may not be available for release.

In no event shall TI's liability arising out of such information exceed the total purchase price of the TI part(s) at issue in this document sold by TI to Customer on an annual basis.

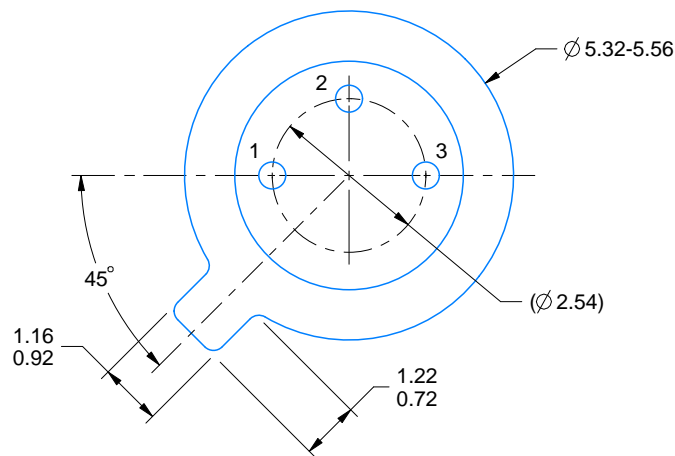
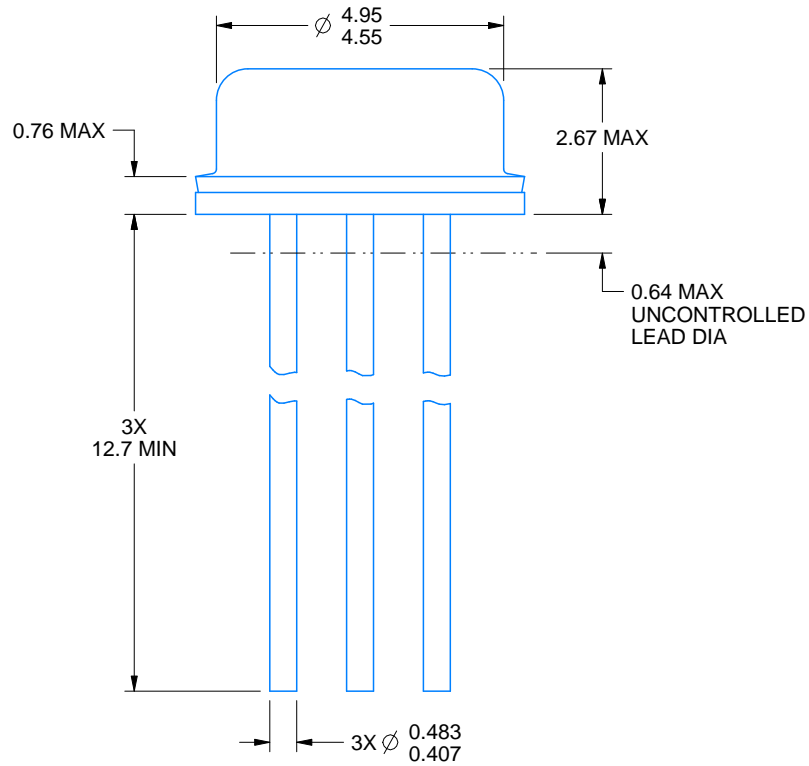

4219876/A 01/2017

NOTES:

1. All linear dimensions are in millimeters. Any dimensions in parenthesis are for reference only. Dimensioning and tolerancing per ASME Y14.5M.
2. This drawing is subject to change without notice.
3. Reference JEDEC registration TO-46.

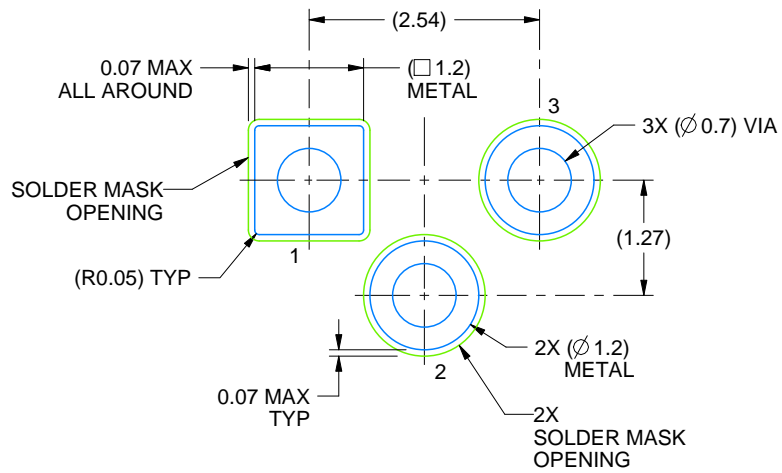

LAND PATTERN EXAMPLE  
NON-SOLDER MASK DEFINED  
SCALE:12X

## IMPORTANT NOTICE AND DISCLAIMER

TI PROVIDES TECHNICAL AND RELIABILITY DATA (INCLUDING DATASHEETS), DESIGN RESOURCES (INCLUDING REFERENCE DESIGNS), APPLICATION OR OTHER DESIGN ADVICE, WEB TOOLS, SAFETY INFORMATION, AND OTHER RESOURCES "AS IS" AND WITH ALL FAULTS, AND DISCLAIMS ALL WARRANTIES, EXPRESS AND IMPLIED, INCLUDING WITHOUT LIMITATION ANY IMPLIED WARRANTIES OF MERCHANTABILITY, FITNESS FOR A PARTICULAR PURPOSE OR NON-INFRINGEMENT OF THIRD PARTY INTELLECTUAL PROPERTY RIGHTS.

These resources are intended for skilled developers designing with TI products. You are solely responsible for (1) selecting the appropriate TI products for your application, (2) designing, validating and testing your application, and (3) ensuring your application meets applicable standards, and any other safety, security, or other requirements. These resources are subject to change without notice. TI grants you permission to use these resources only for development of an application that uses the TI products described in the resource. Other reproduction and display of these resources is prohibited. No license is granted to any other TI intellectual property right or to any third party intellectual property right. TI disclaims responsibility for, and you will fully indemnify TI and its representatives against, any claims, damages, costs, losses, and liabilities arising out of your use of these resources.

TI's products are provided subject to TI's Terms of Sale ([www.ti.com/legal/termsofsale.html](http://www.ti.com/legal/termsofsale.html)) or other applicable terms available either on [ti.com](http://ti.com) or provided in conjunction with such TI products. TI's provision of these resources does not expand or otherwise alter TI's applicable warranties or warranty disclaimers for TI products.

Mailing Address: Texas Instruments, Post Office Box 655303, Dallas, Texas 75265  
Copyright © 2020, Texas Instruments Incorporated