

目录

1	特性	1	7.3	Feature Description	13
2	应用	1	7.4	Device Functional Modes	22
3	说明	1	8	Application and Implementation	23
4	修订历史记录	2	8.1	Application Information	23
5	Pin Configuration and Functions	3	8.2	Typical Application	23
6	Specifications	4	9	Power Supply Recommendations	34
6.1	Absolute Maximum Ratings	4	10	Layout	34
6.2	ESD Ratings	4	10.1	Layout Guidelines	34
6.3	Recommended Operating Conditions	4	10.2	Layout Example	34
6.4	Thermal Information	4	11	器件和文档支持	36
6.5	Electrical Characteristics	5	11.1	器件支持	36
6.6	Timing Requirements	6	11.2	接收文档更新通知	36
6.7	Switching Characteristics	6	11.3	社区资源	36
6.8	Typical Characteristics	7	11.4	商标	36
7	Detailed Description	12	11.5	静电放电警告	36
7.1	Overview	12	11.6	Glossary	36
7.2	Functional Block Diagram	13	12	机械、封装和可订购信息	36

4 修订历史记录

日期	修订版本	说明
2019 年 5 月	*	初始发行版

5 Pin Configuration and Functions

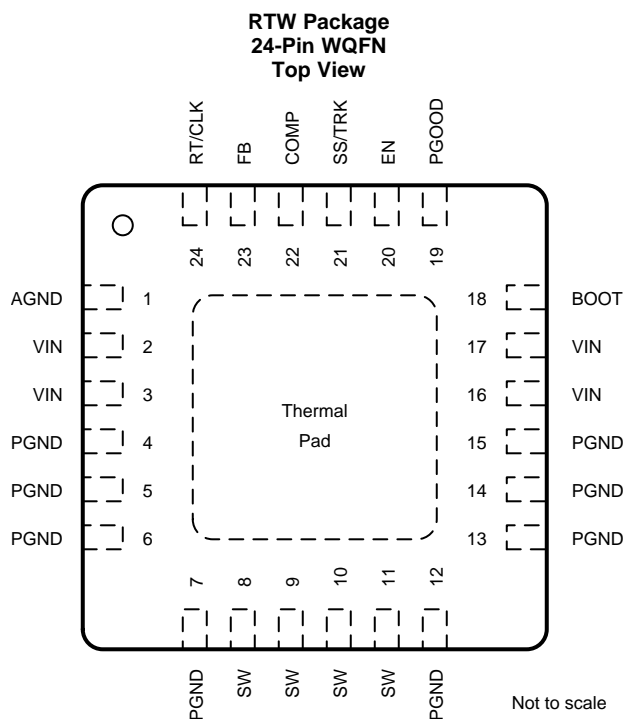

Pin Functions

PIN		I/O	DESCRIPTION
NAME	NO.		
AGND	1	–	Ground of internal analog circuitry. AGND must be connected to PGND for proper operation. Connect to PGND in a region outside of the critical switching loop.
VIN	2, 3, 16, 17	I	Input voltage supply pin. Power for the internal circuit and the connection to drain of high-side MOSFET. Connect both pins to the input power source with a low impedance connection. Connect both pins and their neighboring PGND pins.
PGND	4, 5, 6, 7, 12, 13, 14, 15	–	Ground return for low-side power MOSFET and its drivers.
SW	8, 9, 10, 11	O	Switching node. Connected to the source of the high-side MOSFET and drain of the low-side MOSFET.
BOOT	18	I	Floating supply voltage for high-side MOSFET gate drive circuit. Connect a 0.1- μ F ceramic capacitor between BOOT and SW pins.
PGOOD	19	O	Open-drain power good indicator. It is asserted low if output voltage is outside if the PGOOD thresholds, VIN is low, EN is low, device is in thermal shutdown or device is in soft start.
EN	20	I	Enable pin. Float or pull high to enable the device. Connect a resistor divider to this pin to implement adjustable under voltage lockout and hysteresis.
SS/TRK	21	I	Soft-start and tracking pin. Connecting an external capacitor sets the soft-start time. This pin can also be used for tracking and sequencing.
COMP	22	I	Error amplifier output and input to the PWM modulator. Connect loop compensation to this pin.
FB	23	I	Converter feedback input. Connect to the output voltage with a resistor divider.
RT/CLK	24	I	Switching frequency setting pin. In RT mode, an external timing resistor adjusts the switching frequency. In CLK mode, the device synchronizes to an external clock input to this pin.
Thermal PAD	–	–	Exposed thermal pad. Connect to PGND pins and to internal ground planes using multiple vias for good thermal performance.

6 Specifications

6.1 Absolute Maximum Ratings

over operating free-air temperature range (unless otherwise noted)⁽¹⁾

		MIN	MAX	UNIT
Voltage	VIN	-0.3	19	V
	BOOT	-0.3	27	
	BOOT (10 ns transient)	-0.3	30	
	BOOT (vs SW)	-0.3	7	
	SW	-1	20	
	SW (10 ns transient)	-3	23	
	EN, SS/TRK, PGOOD, RT/CLK, FB, COMP	-0.3	6.5	
Operating junction temperature, T _J		-40	150	°C
Storage temperature, T _{STG}		-55	150	°C

- (1) Stresses beyond those listed under Absolute Maximum Ratings may cause permanent damage to the device. These are stress ratings only, which do not imply functional operation of the device at these or any other conditions beyond those indicated under Recommended Operating Conditions. Exposure to absolute-maximum-rated conditions for extended periods may affect device reliability.

6.2 ESD Ratings

			VALUE	UNIT
V _(ESD)	Electrostatic discharge	Human body model (HBM), per ANSI/ESDA/JEDEC JS-001, all pins ⁽¹⁾	±2000	V
		Charged device model (CDM), per JEDEC specification JESD22-C101, all pins ⁽²⁾	±500	

- (1) JEDEC document JEP155 states that 500-V HBM allows safe manufacturing with a standard ESD control process.

- (2) JEDEC document JEP157 states that 250-V CDM allows safe manufacturing with a standard ESD control process.

6.3 Recommended Operating Conditions

over operating free-air temperature range (unless otherwise noted)

Parameter		MIN	NOM	MAX	UNIT
V _{IN}	Input voltage range	4.5		17	V
V _{OUT}	Output Voltage	0.6		12	V
I _{OUT}	Output current			10	A
T _J	Operating junction temperature	-40		150	°C
f _{SW}	Switching Frequency (RT mode and PLL mode)	200		1600	kHz

6.4 Thermal Information

THERMAL METRIC ⁽¹⁾		TPS54A24	UNIT
		RTW	
		24 PINS	
R _{θJA}	Junction-to-ambient thermal resistance JEDEC	37.5	°C/W
R _{θJA}	Junction-to-ambient thermal resistance EVM	21	°C/W
R _{θJC(top)}	Junction-to-case (top) thermal resistance	22.8	°C/W
R _{θJB}	Junction-to-board thermal resistance	12.5	°C/W
Ψ _{JT}	Junction-to-top characterization parameter	0.3	°C/W
Ψ _{JB}	Junction-to-board characterization parameter	12.5	°C/W
R _{θJC(bot)}	Junction-to-case (bottom) thermal resistance	1.5	°C/W

- (1) For more information about traditional and new thermal metrics, see the [Semiconductor and IC Package Thermal Metrics](#) application report, SPRA953.

6.5 Electrical Characteristics

 $T_J = -40^{\circ}\text{C}$ to 150°C , $V_{(VIN)} = 4.5\text{ V}$ to 17 V (unless otherwise noted)

PARAMETER	TEST CONDITIONS	MIN	TYP	MAX	UNIT	
INPUT VOLTAGE						
UVLO_rise	VIN undervoltage lockout	$V_{(VIN)}$ rising	4.1	4.3	V	
UVLO_fall		$V_{(VIN)}$ falling	3.7	3.9	V	
UVLO_hys		Hysteresis VIN voltage		0.2		V
Ivin	Operating non-switching supply current	$V_{(EN)} = 5\text{ V}$, $V_{(FB)} = 1.5\text{ V}$	580	800	μA	
Ivin_sdn	Shutdown supply current	$V_{(EN)} = 0\text{ V}$	3	11	μA	
ENABLE						
Ven_rise	EN threshold	$V_{(EN)}$ rising	1.20	1.26	V	
Ven_fall		$V_{(EN)}$ falling	1.1	1.15	V	
Ven_hys	EN pin threshold voltage hysteresis		50		mV	
I _p	EN pin sourcing current	$V_{(EN)} = 1.1\text{ V}$	1.2		μA	
I _{ph}	EN pin sourcing current	$V_{(EN)} = 1.3\text{ V}$	4.8		μA	
I _h	EN pin hysteresis current		3.6		μA	
FB						
V _{FB}	Regulated FB voltage	$T_J = 25^{\circ}\text{C}$	596	600	604	mV
			595	600	605	mV
ERROR AMPLIFIER						
g _{mea}	Error amplifier transconductance (gm)	$-2\ \mu\text{A} < I_{(COMP)} < 2\ \mu\text{A}$, $V_{(COMP)} = 1\text{ V}$	1100		$\mu\text{A/V}$	
	Error amplifier DC gain		80		dB	
I _{comp_src}	Error amplifier source current	$V_{(FB)} = 0\text{ V}$	100		μA	
I _{comp_snk}	Error amplifier sink current	$V_{(FB)} = 2\text{ V}$	-100		μA	
g _{mps}	Power stage transconductance		17		A/V	
SS/TRK						
I _{ss}	Soft start current		5		μA	
	$V_{(SS/TRK)}$ to $V_{(FB)}$ matching	$V_{(SS/TRK)} = 0.4\text{ V}$	30		mV	
MOSFET						
R _{ds(on)_h}	High-side switch resistance (VIN pins to SW pins)	$T_A = 25^{\circ}\text{C}$, $V_{(VIN)} = 12\text{ V}$	21		m Ω	
		$T_A = 25^{\circ}\text{C}$, $V_{(VIN)} = 4.5\text{ V}$, $V_{(BOOT-SW)} = 4.5\text{ V}$	23		m Ω	
R _{ds(on)_l}	Low-side switch resistance (SW pins to PGND pins)	$T_A = 25^{\circ}\text{C}$, $V_{(VIN)} = 12\text{ V}$	8		m Ω	
		$T_A = 25^{\circ}\text{C}$, $V_{(VIN)} = 4.5\text{ V}$	9		m Ω	
	BOOT UVLO Falling		2.2	2.6	V	
CURRENT LIMIT						
I _{oc_HS_pk}	High-side peak current limit	$V_{(VIN)} = 12\text{ V}$, $T_J = 25^{\circ}\text{C}$	13.4	14.6	15.8	A
I _{oc_LS_snk}	Low-side sinking current limit	$V_{(VIN)} = 12\text{ V}$	-3.4		A	
I _{oc_LS_src}	Low-side sourcing current limit	$V_{(VIN)} = 12\text{ V}$	10	12.9	14.6	A
RT/CLK						
V _{IH}	Logic high input voltage		2		V	
V _{IL}	Logic low input voltage			0.8	V	
PGOOD						
	Power good threshold	$V_{(FB)}$ rising (fault)	104%	108%		
		$V_{(FB)}$ falling (good)		106%		
		$V_{(FB)}$ rising (good)		91%		
		$V_{(FB)}$ falling (fault)		89%	95%	
I _{pg_lkg}	Leakage current into PGOOD pin when pulled high	$V_{(PGOOD)} = 5\text{ V}$	5		nA	
V _{pg_low}	PGOOD voltage when pulled low	$I_{(PGOOD)} = 2\text{ mA}$	0.18	0.22	V	
	Minimum VIN for valid output	$V_{(PGOOD)} < 0.5\text{ V}$, $I_{(PGOOD)} = 2.5\text{ mA}$	0.9	1	V	
THERMAL PROTECTION						
T _{TRIP}	Thermal protection trip point	Temperature rising	170		$^{\circ}\text{C}$	
T _{HYST}	Thermal protection hysteresis		15		$^{\circ}\text{C}$	

6.6 Timing Requirements

 $T_J = -40^{\circ}\text{C}$ to 150°C , $V_{(VIN)} = 4.5\text{ V}$ to 17 V (unless otherwise noted)

		MIN	NOM	MAX	UNIT
	Minimum synchronization signal pulse width (PLL mode)			35	ns

6.7 Switching Characteristics

 $T_J = -40^{\circ}\text{C}$ to 150°C , $V_{(VIN)} = 4.5\text{ V}$ to 17 V (unless otherwise noted)

PARAMETER		TEST CONDITIONS	MIN	TYP	MAX	UNIT
EN						
	EN to start of switching			135		μs
PGOOD						
	Deglitch time PGOOD going high			272		Cycles
	Deglitch time PGOOD going low			16		Cycles
SW						
ton_min	Minimum on time	Measured at 50% to 50% of $V_{(VIN)}$, $L = 1.0\ \mu\text{H}$, $I_{OUT} = 0\text{ A}$		90		ns
toff_min	Minimum off time ⁽¹⁾	$V_{(BOOT-SW)} \geq 2.6\text{ V}$			0	ns
RT/CLK						
fsw_min	Minimum switching frequency (RT mode)	$R_{(RT/CLK)} = 250\text{ k}\Omega$		200		kHz
	Switching frequency (RT mode)	$R_{(RT/CLK)} = 100\text{ k}\Omega$	450	500	550	kHz
fsw_max	Maximum switching frequency (RT mode)	$R_{(RT/CLK)} = 30.1\text{ k}\Omega$		1.6		MHz
fsw_clk	Switching frequency synchronization range (PLL mode)		200		1600	kHz
	RT/CLK falling edge to SW rising edge delay (PLL mode)	Measure at 500kHz with RT resistor in series with RT/CLK		70		ns
HICCUP						
	Wait time before hiccup			512		Cycles
	Hiccup time before restart			16384		Cycles

(1) Specified by design.

6.8 Typical Characteristics



图 1. Efficiency with 5-V Input and 500-kHz Switching Frequency



图 2. Efficiency With 5-V and 9-V Output

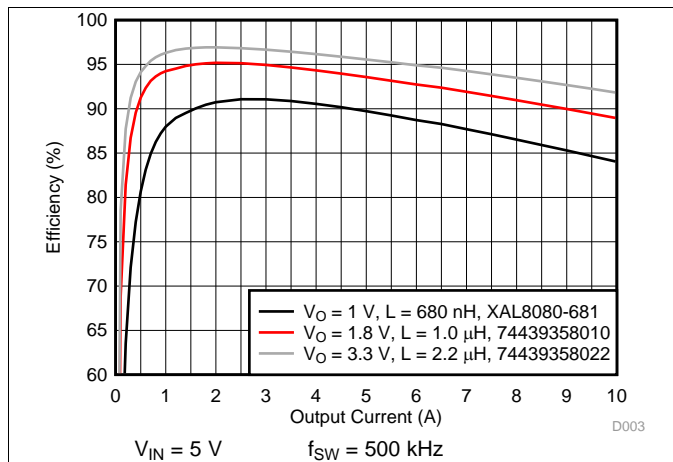

图 3. Efficiency With 5-V Input, 500-kHz Switching Frequency and 6.36-mm x 6.56-mm Inductor

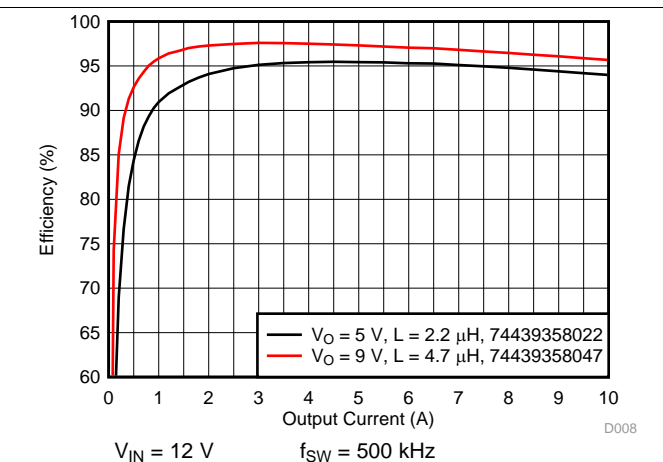

图 4. Efficiency With 12-V Input, 500-kHz Switching Frequency and 6.36 mm x 6.56 mm Inductor

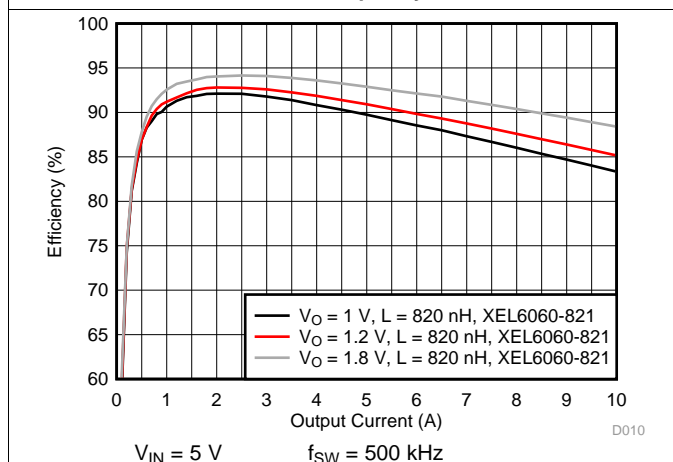

图 5. Efficiency With 5-V Input and 1 MHz Switching Frequency

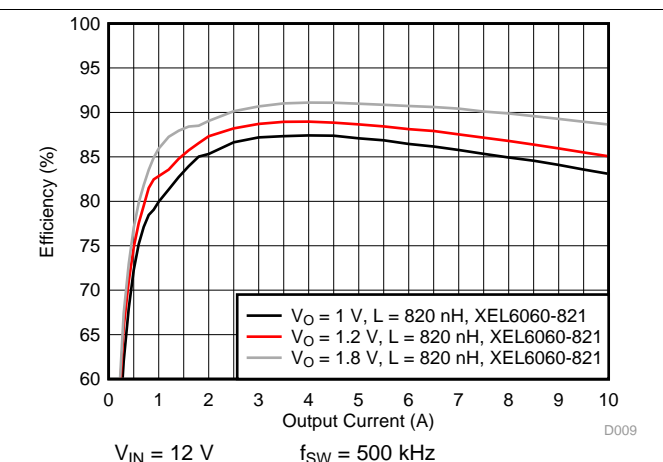

图 6. VIN Pin Nonswitching Supply Current vs Junction Temperature

Typical Characteristics (接下页)

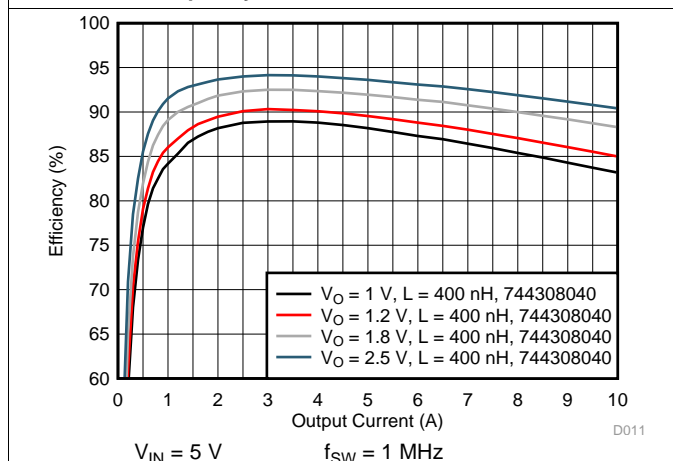

图 7. VIN Pin Shutdown Current vs Junction Temperature

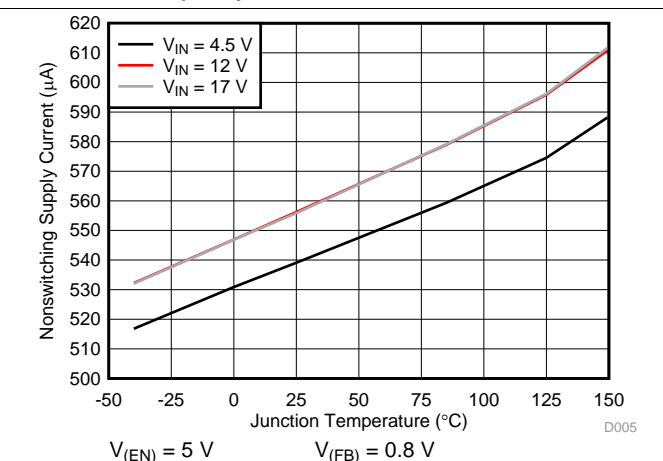

图 8. EN Pin Voltage Threshold vs Junction Temperature

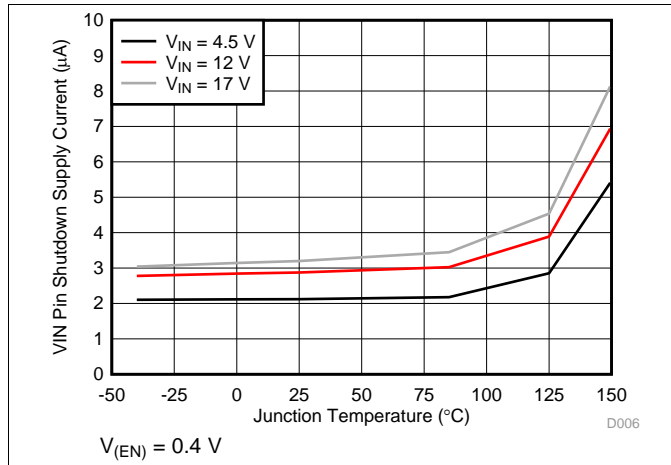

图 9. EN Pin Current vs Junction Temperature

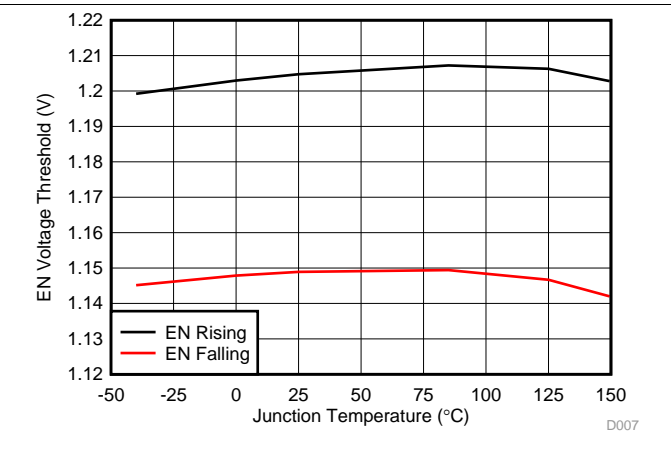

图 10. Regulated FB Voltage vs Junction Temperature

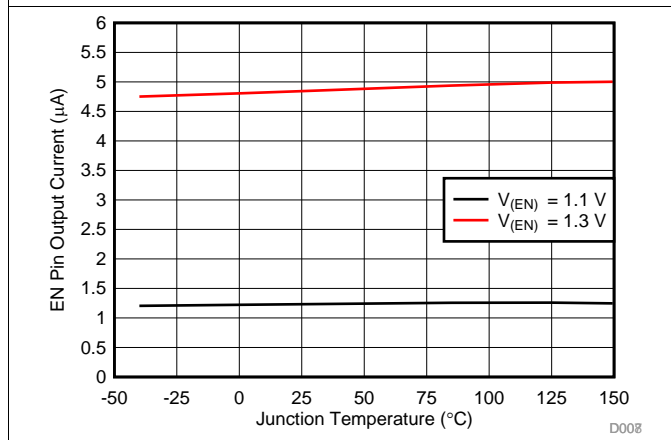

图 11. MOSFET $R_{DS(on)}$ vs Junction Temperature

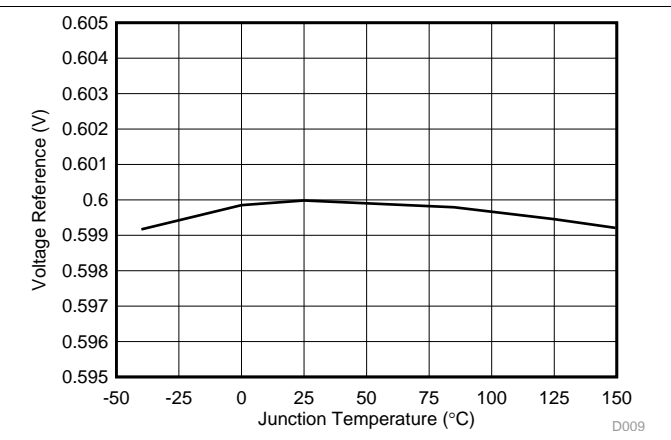

图 12. Error Amplifier Transconductance vs Junction Temperature

Typical Characteristics (接下页)

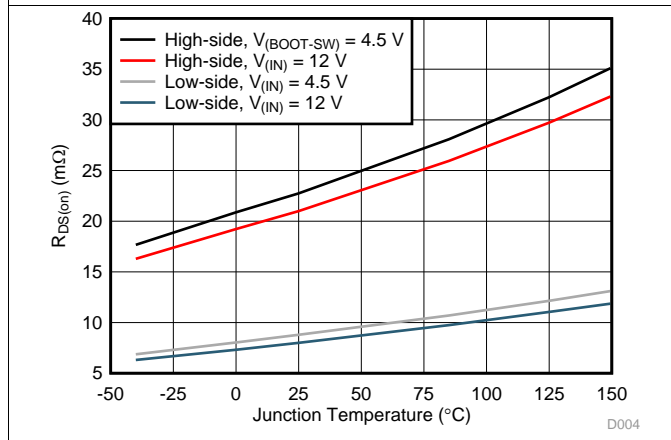

图 13. $V_{(COMP)}$ to $I_{(SW)}$ Transconductance vs Ambient Temperature

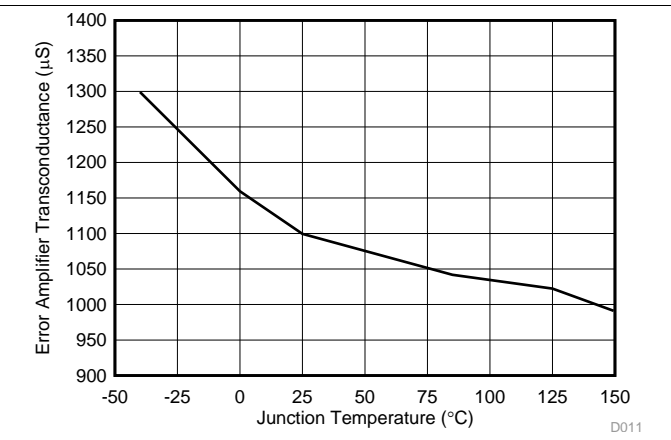

图 14. SS/TRK Current vs Junction Temperature

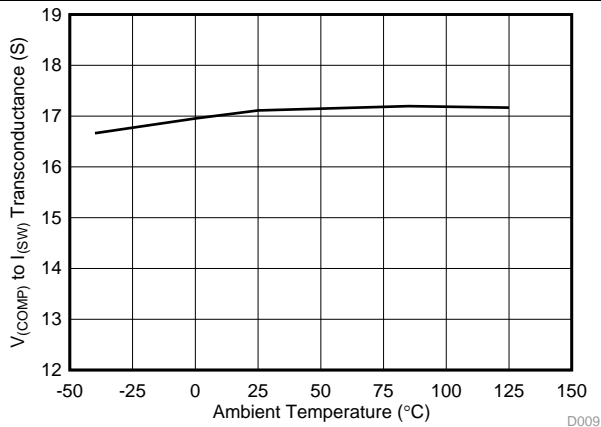

图 15. SS/TRK to FB Offset vs Junction Temperature

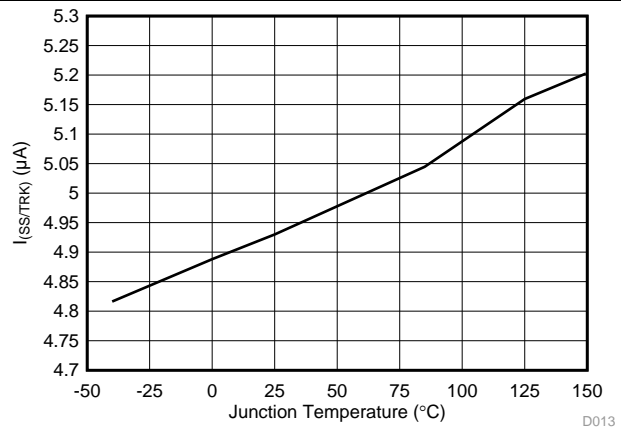

图 16. FB voltage vs SS/TRK Voltage

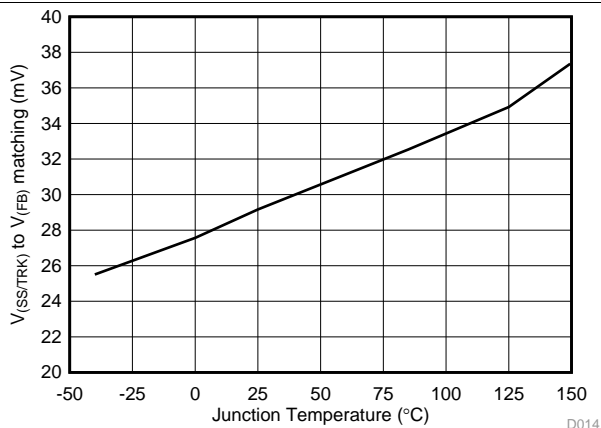

图 17. High-side Peak Current Limit vs Ambient Temperature

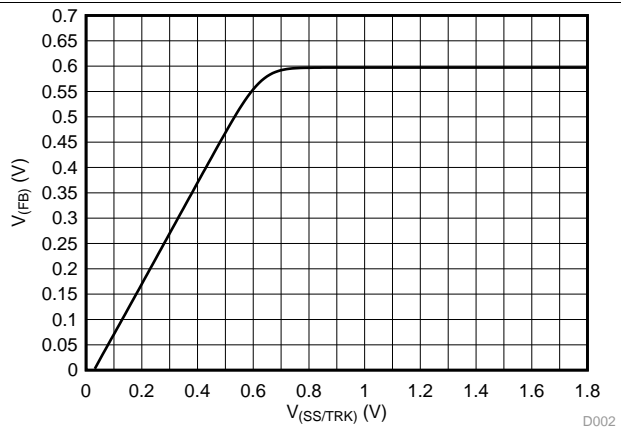

图 18. PGOOD Thresholds vs Junction Temperature

Typical Characteristics (接下页)

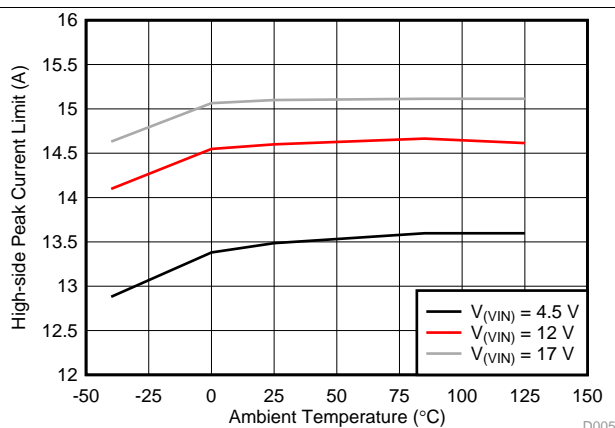

Typical Characteristics (接下页)

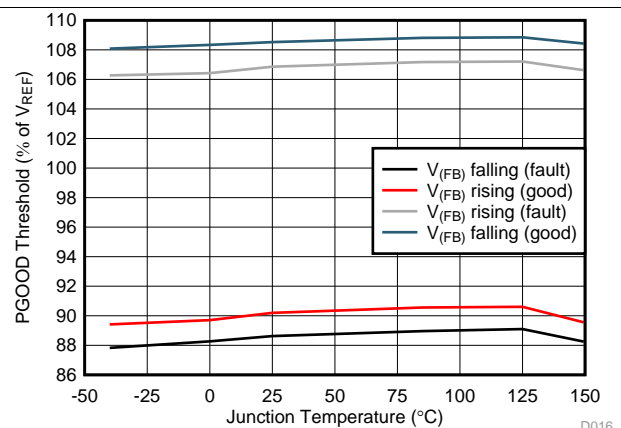
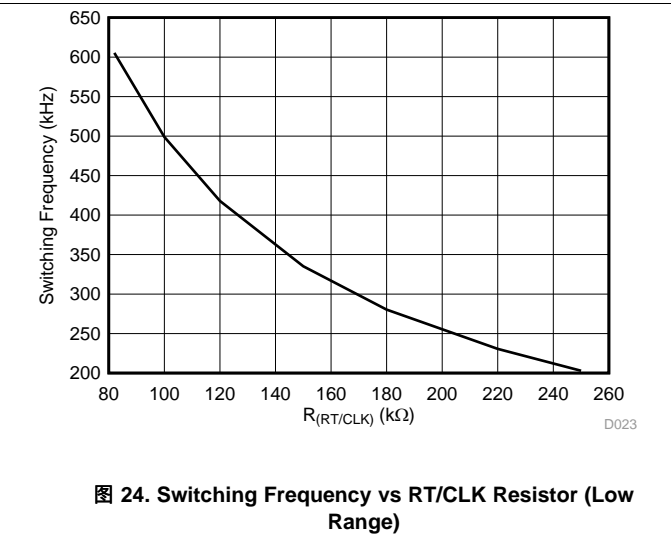
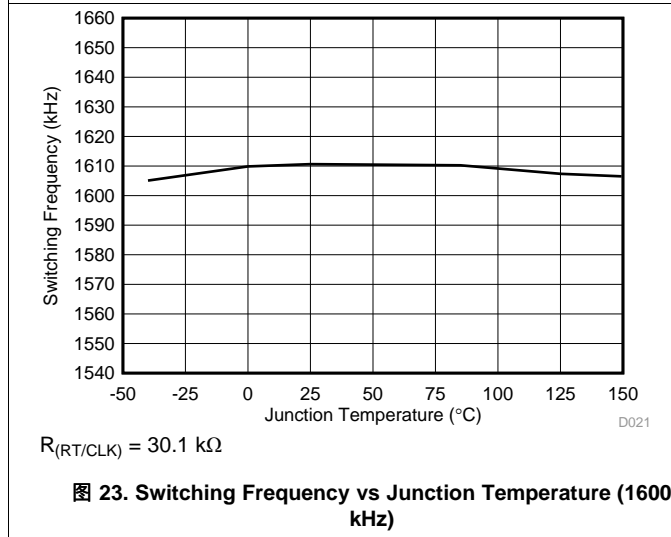
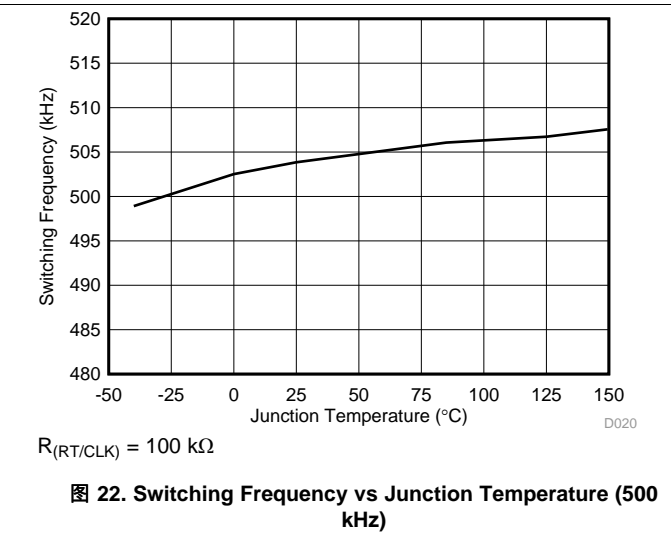
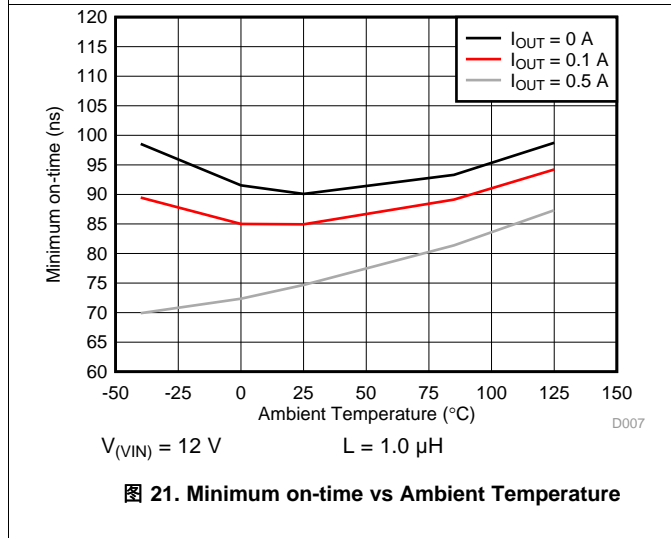
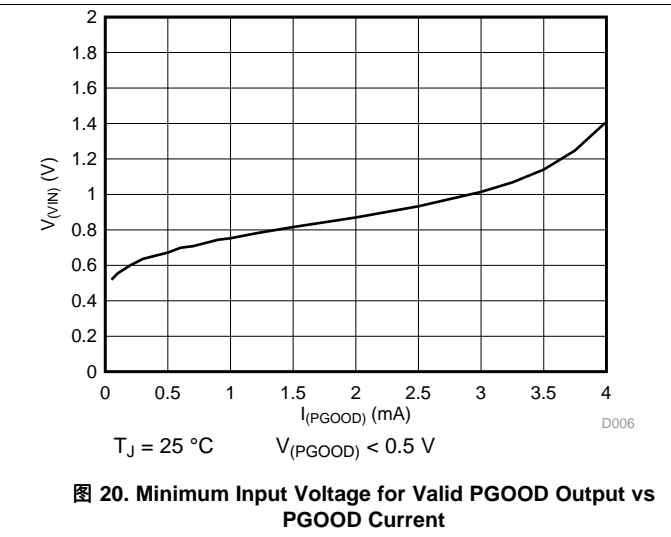
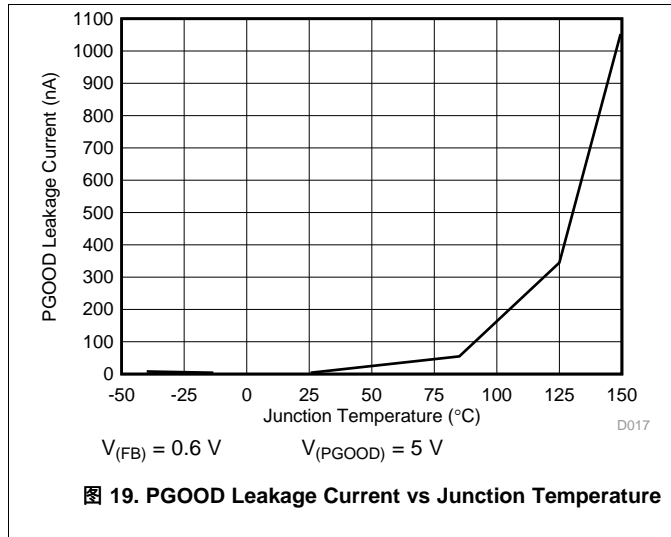

图 25. Switching Frequency vs RT/CLK Resistor (High Range)

7 Detailed Description

7.1 Overview

The TPS54A24 is a 17-V, 10-A, synchronous step-down (buck) converter with two integrated n-channel MOSFETs. To improve performance during line and load transients the device implements a constant frequency, peak current mode control which also simplifies external frequency compensation. The wide switching frequency of 200 kHz to 1600 kHz allows for efficiency and size optimization when selecting the output filter components. The switching frequency is adjusted using a resistor to ground on the RT/CLK pin. The TPS54A24 also has an internal phase lock loop (PLL) connected to the RT/CLK pin that can be used to synchronize the switching cycle to the falling edge of an external system clock.

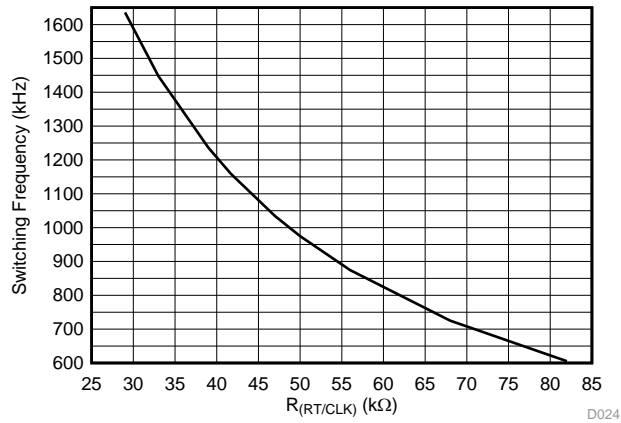
The integrated MOSFETs allow for high efficiency power supply designs with continuous output currents up to 10 amperes. The MOSFETs have been sized to optimize efficiency for lower duty cycle applications. The device reduces the external component count by integrating a bootstrap recharge circuit. The bias voltage for the integrated high-side MOSFET is supplied by a capacitor between the BOOT and SW pins. The BOOT capacitor voltage is monitored by a BOOT to SW UVLO (BOOT-SW UVLO) circuit allowing SW pin to be pulled low to recharge the BOOT capacitor. The device can operate at 100% duty cycle as long as the BOOT capacitor voltage is higher than the preset BOOT-SW UVLO threshold which is typically 2.2 V.

The TPS54A24 has been designed for safe startup into pre-biased loads. The default start up is when VIN is typically 4.1 V. The EN pin has an internal pullup current source that can be used to adjust the input voltage under voltage lockout (UVLO) with two external resistors. In addition, the internal pullup current of the EN pin allows the device to operate with the EN pin floating. The operating current for the TPS54A24 is typically 580 μ A when not switching and under no load. When the device is disabled, the supply current is typically 3 μ A.

The SS/TRK (soft start/tracking) pin is used to minimize inrush currents or provide power supply sequencing during power up. A small value capacitor or resistor divider should be coupled to the pin for soft start or critical power supply sequencing requirements. The output voltage can be stepped down to as low as the 0.6 V voltage reference (V_{REF}). The device has a power good comparator (PGOOD) with hysteresis which monitors the output voltage through the FB pin. The PGOOD pin is an open drain MOSFET which is pulled low when the FB pin voltage is less than 89% or greater than 108% of the reference voltage V_{REF} and asserts high when the FB pin voltage is 91% to 106% of V_{REF} .

The device is protected from output overvoltage, overload and thermal fault conditions. The device minimizes excessive output overvoltage transients by taking advantage of the overvoltage circuit power good comparator. When the overvoltage comparator is activated, the high-side MOSFET is turned off and prevented from turning on until the FB pin voltage is lower than 106% of the V_{REF} . The device implements both high-side MOSFET over current protection and bidirectional low-side MOSFET over current protections which help control the inductor current and avoid current runaway. The device also shuts down if the junction temperature is higher than thermal shutdown trip point. The device is restarted under control of the soft start circuit automatically when the junction temperature drops 15°C typically below the thermal shutdown trip point.

7.2 Functional Block Diagram

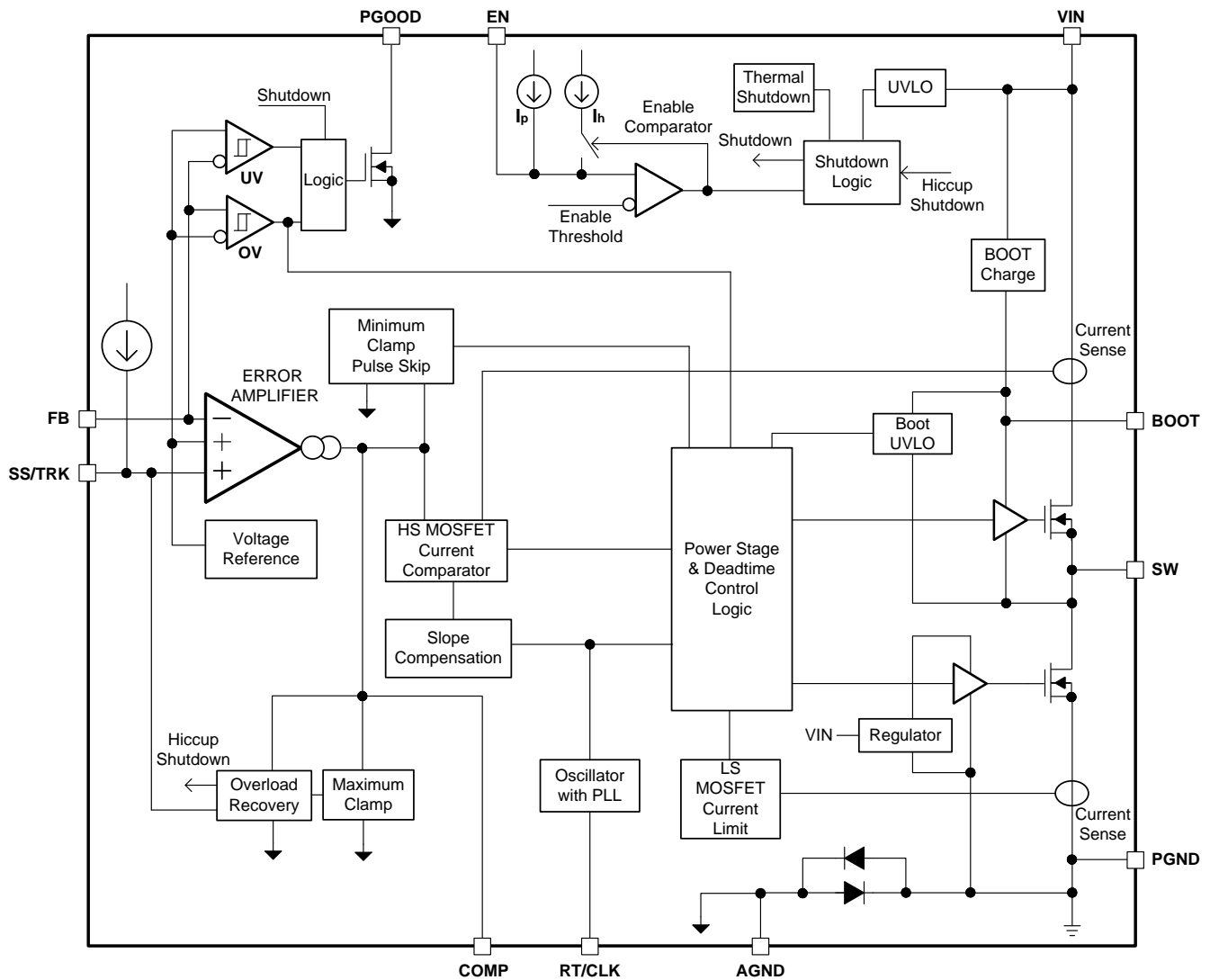

Copyright © 2016, Texas Instruments Incorporated

7.3 Feature Description

7.3.1 Fixed Frequency PWM Control

The device uses an adjustable fixed-frequency, peak-current-mode control. The output voltage is compared through external resistors on the FB pin to an internal voltage reference by an error amplifier which drives the COMP pin. An internal oscillator initiates the turn on of the high-side power switch. The error amplifier output is converted into a current reference which compares to the high-side power switch current. When the power switch current reaches current reference generated by the COMP voltage level the high-side power switch is turned off and the low-side power switch is turned on.

The device adds an internal slope compensation ramp to prevent subharmonic oscillations. The peak inductor current limit remains constant over the full duty cycle range.

7.3.2 Continuous Conduction Mode Operation (CCM)

As a synchronous buck converter, the device works in continuous conduction mode (CCM) under all load conditions.

Feature Description (接下页)

7.3.3 VIN Pins and VIN UVLO

The VIN pin voltage supplies the internal control circuits of the device and provides the input voltage to the power converter system. The input voltage for VIN can range from 4.5 V to 17 V. The device implements internal UVLO circuitry on the VIN pin. The device is disabled when the VIN pin voltage falls below the internal VIN UVLO threshold. The internal VIN UVLO threshold has a hysteresis of 200 mV. A voltage divider connected to the EN pin can adjust the input voltage UVLO appropriately. See [Enable and Adjustable UVLO](#) for more details.

7.3.4 Voltage Reference and Adjusting the Output Voltage

The voltage reference system produces a precise $\pm 0.85\%$, 0.6-V voltage reference over temperature by scaling the output of a temperature stable band gap circuit. The output voltage is set with a resistor divider from the output (V_{OUT}) to the FB pin shown in [图 26](#). TI recommends using 1%-tolerance or better divider resistors. Start with a fixed value for the bottom resistor in the divider, typically 5.1 k Ω or less, then use [公式 1](#) to calculate the top resistor in the divider. If the values are too high the regulator is more susceptible to noise and voltage errors from the FB input current are noticeable. If the values too high and if switching stops after low-side reverse current limit trips or when in thermal shutdown, bias current out of the SW pin can charge up the output voltage. Using 5.1-k Ω bottom resistance or less prevents the bias current out of the SW pin from charging the output voltage above the set value. Larger resistance may be used if his bias current is accounted for. The minimum output voltage and maximum output voltage can be limited by the minimum on time of the high-side MOSFET and bootstrap voltage (BOOT-SW voltage), respectively.

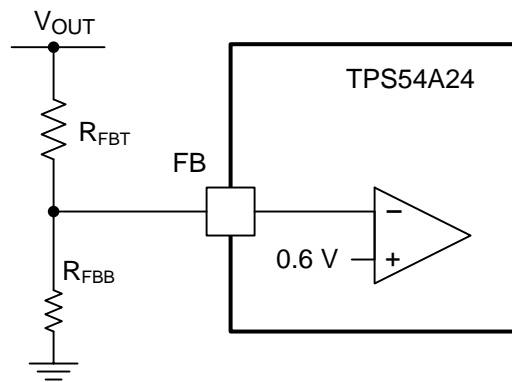

Copyright © 2018, Texas Instruments Incorporated

图 26. FB Resistor Divider

$$R_{FBT} = R_{FBB} \times \left(\frac{V_{OUT}}{V_{REF}} - 1 \right)$$

(1)

7.3.5 Error Amplifier

The device uses a transconductance error amplifier. The error amplifier compares the FB pin voltage to the lower of the SS/TRK pin voltage or the internal 0.6-V voltage reference. The transconductance of the error amplifier is 1100 $\mu\text{A/V}$. The frequency compensation network is connected between the COMP pin and ground.

When operating at current limit the COMP pin voltage is clamped to a maximum level to improve response when the load current decreases. When FB is greater than the internal voltage reference or SS/TRK the COMP pin voltage is clamped to a minimum level and the devices enters a high-side skip mode.

Feature Description (接下页)

7.3.6 Enable and Adjustable UVLO

The EN pin provides on/off control of the device. Once the EN pin voltage exceeds its threshold voltage, the device starts operation. If the EN pin voltage is pulled below the threshold voltage, the regulator stops switching and enters low operating current state. The EN pin has an internal pullup current source, I_p , allowing the user to float the EN pin for enabling the device. If an application requires controlling the EN pin, an open drain or open collector output logic can be interfaced with the pin.

An external resistor divider can be added from VIN to the EN pin for adjustable UVLO and hysteresis as shown in 图 27. The EN pin has a small pullup current I_p which sets the default state of the pin to enable when no external components are connected. The pullup current is also used to control the voltage hysteresis for the UVLO function since it increases by I_h once the EN pin crosses the enable threshold. The UVLO thresholds can be calculated using 公式 2 and 公式 3. When using the adjustable UVLO function, 500 mV or greater hysteresis is recommended. For applications with very slow input voltage slew rate, a capacitor can be placed from the EN pin to ground to filter any glitches on the input voltage.

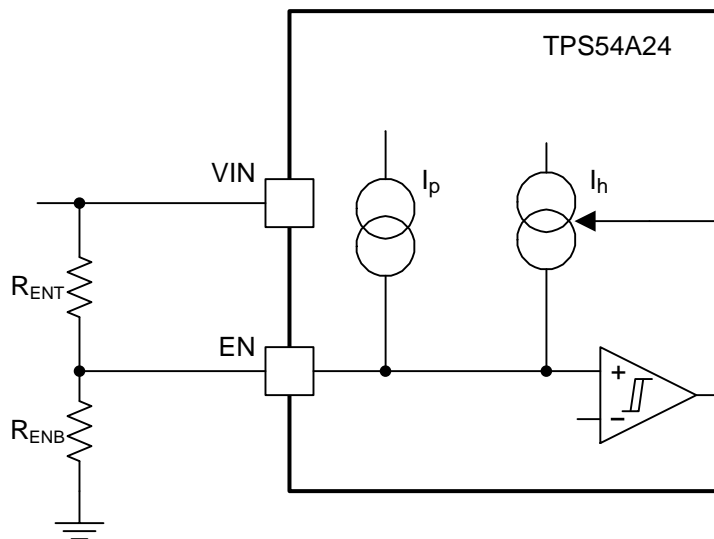

Copyright © 2018, Texas Instruments Incorporated

图 27. Adjustable UVLO Using EN

$$R_{ENT} = \frac{V_{START} \times \left(\frac{V_{ENFALLING}}{V_{ENRISING}} \right) - V_{STOP}}{I_p \times \left(1 - \frac{V_{ENFALLING}}{V_{ENRISING}} \right) + I_h} \quad (2)$$

$$R_{ENB} = \frac{R_{ENT} \times V_{ENFALLING}}{V_{STOP} - V_{ENFALLING} + R_{ENT} \times (I_p + I_h)} \quad (3)$$

Feature Description (接下页)

7.3.7 Soft Start and Tracking

The TPS54A24 regulates to the SS/TRK pin while its voltage is lower than the internal reference to implement soft start. A capacitor on the SS/TRK pin to ground sets the soft start time. The SS/TRK pin has an internal pullup current source of 5 μA that charges the external soft start capacitor. 公式 4 calculates the required soft start capacitor value. The FB voltage will follow the SS/TRK pin voltage with a 25 mV offset up to 90% of the internal voltage reference. When the SS/TRK voltage is greater than 90% of the internal reference voltage the offset increases as the effective system reference transitions from the SS/TRK voltage to the internal voltage reference.

$$C_{SS}(\text{nF}) = \frac{I_{SS}(\mu\text{A}) \times t_{SS}(\text{ms})}{V_{REF}(\text{V})} = 8.3 \times t_{SS}(\text{ms}) \quad (4)$$

If during normal operation, VIN goes below the UVLO, EN pin pulled below 1.15 V, or a thermal shutdown event occurs, the TPS54A24 stops switching and the SS/TRK pin floats. When the VIN goes above UVLO, EN goes above 1.2 V, or a thermal shutdown is exited, the SS/TRK pin is discharged to near ground before reinitiating a powering up sequence.

When the COMP pin voltage is clamped by the maximum COMP clamp in an overload condition the SS/TRK pin is discharged to near the FB voltage. When the overload condition is removed, the soft-start circuit controls the recovery from the fault output level to the nominal output regulation voltage. At the beginning of recovery a spike in the output voltage may occur while the COMP voltage transitions from the maximum clamp to the value determined by the loop.

If a nominal SS/TRK capacitance of 22 nF or greater is used, TI recommends adding a 470-k Ω to 1-M Ω resistor in parallel with the SS/TRK capacitor. With higher SS/TRK capacitance and if the EN pin voltage goes low then high quickly, the SS/TRK capacitor may not fully discharge before switching begins. Adding this resistor helps discharge the SS/TRK capacitor. For the SS capacitor to fully discharge, disable the TPS54A24 for a time period equal to 3 times the RC time constant of the SS/TRK capacitor and the added resistor.

7.3.8 Safe Start-Up Into Prebiased Outputs

The device has been designed to prevent the low-side MOSFET from discharging a pre-biased output. During prebiased startup, the low-side MOSFET is not allowed to sink current until the SS/TRK pin voltage is higher than the FB pin voltage and the high-side MOSFET begins to switch. The one exception is if the BOOT-SW voltage is below the UVLO threshold. While in BOOT-SW UVLO, the low-side MOSFET is allowed to turn on to charge the BOOT capacitor. The low-side MOSFET reverse current protection provides another layer of protection for the device after the high-side MOSFET begins to switch.

7.3.9 Power Good

The PGOOD pin is an open-drain output requiring an external pullup resistor to output a high signal. Once the FB pin is between 91% and 106% of the internal voltage reference and SS/TRK is greater than 0.75 V, after a 272 cycle deglitch time the PGOOD pin is de-asserted and the pin floats. A pullup resistor between the values of 10 k Ω and 100 k Ω to a voltage source that is 6.5 V or less is recommended. PGOOD is in a defined state once the VIN input voltage is greater than 1 V but with reduced current sinking capability.

When the FB is lower than 89% or greater than 108% of the nominal internal reference voltage, after a 16 cycle deglitch time the PGOOD pin is pulled low. PGOOD is immediately pulled low if VIN falls below its UVLO, EN pin is pulled low or the TPS54A24 enters thermal shutdown.

Feature Description (接下页)

7.3.10 Sequencing (SS/TRK)

Many of the common power supply sequencing methods can be implemented using the SS/TRK, EN and PGOOD pins.

The sequential method is illustrated in 图 28 using two TPS54A24 or similar devices. The power good of the first device is coupled to the EN pin of the second device which enables the second power supply once the primary supply reaches regulation.

图 29 shows the method implementing ratiometric sequencing by connecting the SS/TRK pins of two devices together. The regulator outputs ramp up and reach regulation at the same time. When calculating the soft-start time the current source must be doubled in 公式 4.



图 28. Sequential Start-Up Sequence



图 29. Ratiometric Start-Up Sequence

Feature Description (接下页)

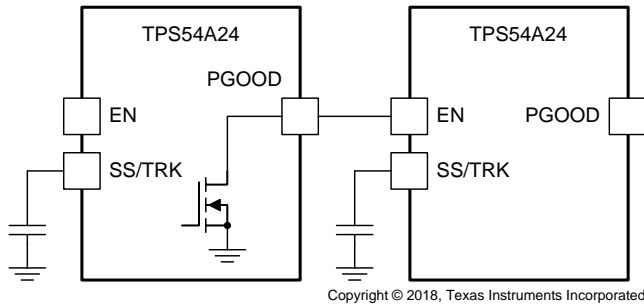
Ratiometric and simultaneous power supply sequencing can be implemented by connecting the resistor network of R_{TRT} and R_{TRB} shown in 图 30 to the output of the power supply that needs to be tracked or another voltage reference source. Using 公式 6 和 公式 7, the tracking resistors can be calculated to initiate the V_{OUT2} slightly before, after or at the same time as V_{OUT1} . 公式 5 is the voltage difference between V_{OUT1} and V_{OUT2} .

To design a ratiometric start-up in which the V_{OUT2} voltage is slightly greater than the V_{OUT1} voltage when V_{OUT2} reaches regulation, use a negative number in 公式 6 和 公式 7 for ΔV . 公式 5 results in a positive number for applications where the V_{OUT2} is slightly lower than V_{OUT1} when V_{OUT2} regulation is achieved.

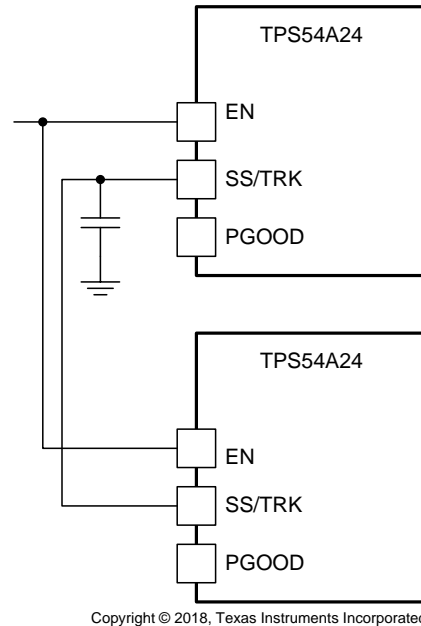
The ΔV variable is zero volts for simultaneous sequencing. To minimize the effect of the inherent SS/TRK to FB offset ($V_{ssoffset} = 25 \text{ mV}$) in the soft-start circuit and the offset created by the pullup current source ($I_{ss} = 5 \mu\text{A}$) and tracking resistors, the $V_{ssoffset}$ and I_{ss} are included as variables in the equations.

When the TPS54A24 is enabled, an internal switch at the SS/TRK pin turns on to discharge the SS/TRK voltage to near ground as described in *Soft Start and Tracking*. The SS/TRK pin voltage must discharge low enough before the TPS54A24 starts up. If there is voltage on V_{OUT1} and the upper resistor at the SS/TRK pin is too small, the SS/TRK pin cannot discharge low enough and V_{OUT2} does not ramp up. The upper resistor in the SS/TRK divider may need to be increased to allow the SS/TRK pin to drop close enough to ground. To ensure proper startup of V_{OUT2} , the calculated R_{TRT} value from 公式 6 must be greater than the value calculated in 公式 8. Calculate R_{TRB} using the final value of R_{TRT} .

$$\Delta V = V_{OUT1} - V_{OUT2} \quad (5)$$

$$R_{TRT} = \frac{V_{OUT2} + \Delta V}{V_{REF}} \times \frac{V_{ssoffset}}{I_{ss}} \quad (6)$$

$$R_{TRB} = \frac{V_{REF} \times R_{TRT}}{V_{OUT2} + \Delta V - V_{REF}} \quad (7)$$

$$R_{TRT} > 20000 \times V_{OUT1} \quad (8)$$

As described in *Power Good*, for the PGOOD output to be active the SS/TRK voltage must be above 0.75 V. The external divider may prevent the SS/TRK voltage from charging above the threshold. For the SS/TRK pin to charge above the threshold, a switch may be needed to disconnect the resistor divider or modify the resistor divider ratio of the V_{OUT2} converter after start-up is complete. The PGOOD pin of the V_{OUT1} converter could be used for this. One solution is to add a resistor from SS/TRK of the V_{OUT2} converter to the PGOOD of the V_{OUT1} converter. While the PGOOD of V_{OUT1} pulls low, this resistor is in parallel with R_{TRB} . When V_{OUT1} is in regulation its PGOOD pin will float. If the PGOOD pin of V_{OUT1} is connected to a pullup voltage, make sure to include this in calculations. A second option is to use the PGOOD pin to turn on or turn off the external switch to change the divide ratio.

Feature Description (接下页)



图 30. Ratiometric and Simultaneous Start-Up Sequence

7.3.11 Adjustable Switching Frequency (RT Mode)

In RT mode, a resistor (RT resistor) is connected between the RT/CLK pin and AGND. The switching frequency of the device is adjustable from 200 kHz to 1600 kHz by placing a maximum of 250 kΩ and minimum of 30.1 kΩ respectively. To determine the RT resistance for a given switching frequency, use 公式 9. To reduce the solution size one would set the switching frequency as high as possible, but tradeoffs of the supply efficiency and minimum controllable on-time must be considered. 公式 10 can be used to calculate the switching frequency for a given RT resistance.

$$RT(k\Omega) = 58650 \times f_{SW}(kHz)^{-1.028} \tag{9}$$

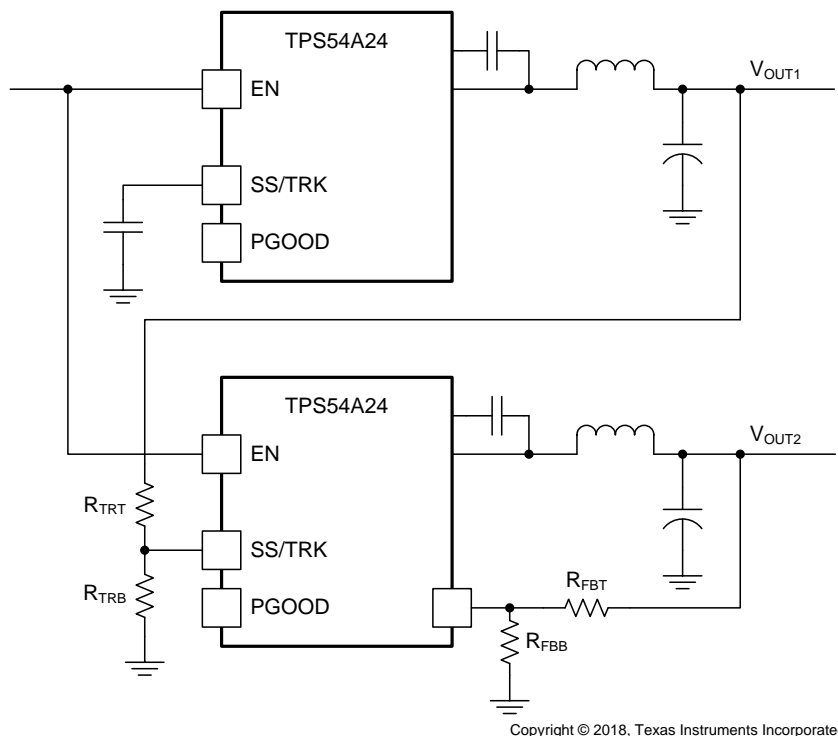
$$f_{SW}(kHz) = 43660 \times RT(k\Omega)^{-0.973} \tag{10}$$

7.3.12 Synchronization (CLK Mode)

An internal phase locked loop (PLL) has been implemented to allow synchronization from 200 kHz to 1600 kHz, and to easily switch from RT mode to CLK mode. To implement the synchronization feature, connect a square wave clock signal to the RT/CLK pin with a duty cycle from 20% to 80%. If the clock signals rising edge occurs near the falling edge of SW, increased SW jitter may occur. Use 公式 11 to calculate the maximum clock pulse width to minimize jitter in CLK mode. The clock signal amplitude must transition lower than 0.8 V and higher than 2 V. The start of the switching cycle is synchronized to the falling edge of the RT/CLK pin.

$$CLK_PW_{MAX} = \frac{0.75 \times \left(1 - \frac{V_{OUT}}{V_{IN(min)}}\right)}{f_{SW}} \tag{11}$$

Feature Description (接下页)

In applications where both RT mode and CLK mode are needed, the device can be configured as shown in 图 31. Before the external clock is present, the device works in RT mode and the switching frequency is set by RT resistor. When the external clock is present, the CLK mode overrides the RT mode. The first time the SYNC pin is pulled above the RT/CLK high threshold (2 V), the device switches from the RT mode to the CLK mode and the RT/CLK pin becomes high impedance as the PLL starts to lock onto the frequency of the external clock.

If the input clock goes away the internal clock frequency begins to drop and after 10 μ s without a clock the device returns to RT mode. Output undershoot while the switching frequency drops can occur. Output overshoot can also occur when the switching frequency steps back up to the RT mode frequency. A high impedance tri-state buffer as shown in 图 33 is recommended for best performance during the transition from CLK mode to RT mode because it minimizes the loading on the RT/CLK pin allowing faster transition back to RT mode. 图 34 shows the typical performance for the transition from RT mode to CLK mode then back to RT mode.

A series RC circuit as shown in 图 32 can also be used to interface the RT/CLK pin but the capacitive load slows down the transition back to RT mode. The series RC circuit is not recommended if the transition from CLK mode to RT mode is important. A capacitor in the range of 47 pF to 470 pF is recommended. When using the series RC circuit verify the amplitude of the signal at the RT/CLK pin goes above the high threshold.



图 31. Simplified Circuit When Using Both RT Mode and CLK Mode

图 32. Interfacing to the RT/CLK Pin with Series RC

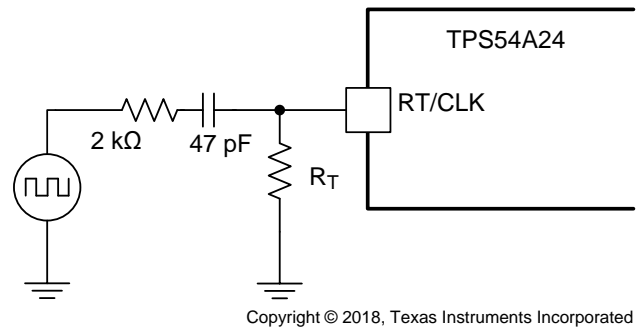
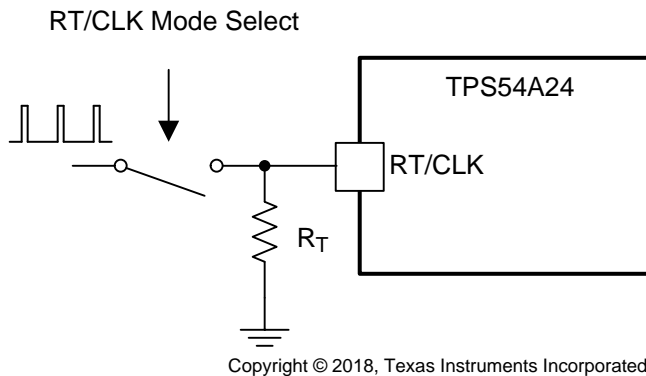

图 33. Interfacing to the RT/CLK Pin with Buffer

图 34. RT to CLK to RT Transition with Buffer

Feature Description (接下页)

7.3.13 Bootstrap Voltage and 100% Duty Cycle Operation (BOOT)

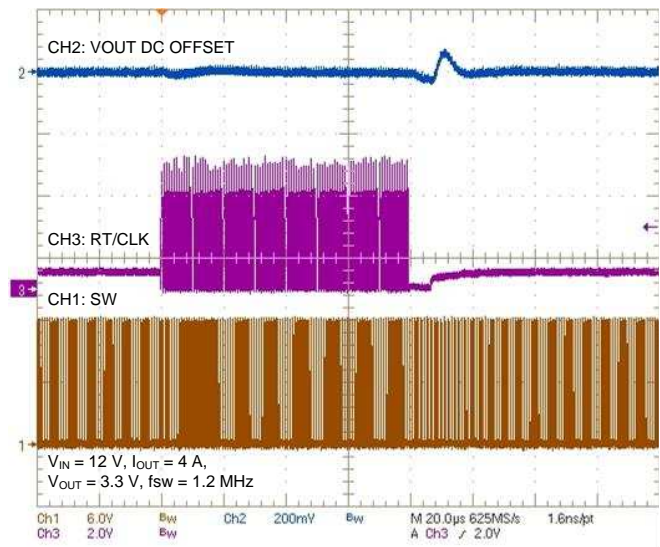
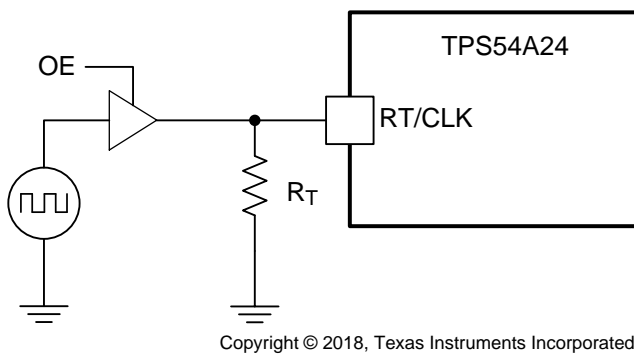
The device provides an integrated bootstrap-voltage regulator. A small capacitor between the BOOT and SW pins provides the gate-drive voltage for the high-side MOSFET. The BOOT capacitor is refreshed when the low-side MOSFET is on. The recommended value of the BOOT capacitor is 0.1 μF . A ceramic capacitor with an X7R or X5R grade dielectric with a voltage rating of 10 V or higher is recommended for stable performance over temperature and voltage.

When operating with a low voltage difference from input to output, the high-side MOSFET of the device operate at 100% duty cycle as long as the BOOT to SW pin voltage is greater than 2.2 V. The device begins to transition to 100% duty cycle operation when the high-side MOSFET off-time is less than 200 ns typical. 公式 12 can be used to estimate the input voltage the switching frequency begins to decrease. When the switching frequency decreases the BOOT to SW capacitor is not recharged as often so the BOOT to SW voltage will start to decrease. If the voltage from BOOT to SW drops below 2.2 V, the high-side MOSFET is turned off due to BOOT UVLO and the low-side MOSFET pulls SW low to recharge the BOOT capacitor. When operating at 100% duty cycle the high-side MOSFET can remain on for many switching cycles before the MOSFET is turned off to refresh the capacitor because the gate drive current sourced by the BOOT capacitor is small. The effective switching frequency reduced and the effective maximum duty cycle of the switching regulator is near 100%. The output voltage of the converter during dropout is mainly influenced by the voltage drops across the power MOSFET, the inductor resistance, and the printed circuit board resistance.

$$V_{\text{IN}} = \frac{V_{\text{OUT}} + (R_{\text{DS}}(\text{LS}) + R_{\text{DCR}}) \times I_{\text{OUT}}}{1 - t_{\text{OFF}} \times f_{\text{SW}}} + (R_{\text{DS}}(\text{HS}) - R_{\text{DS}}(\text{LS})) \times I_{\text{OUT}}$$

where

- $R_{\text{DS}}(\text{LS})$ = low-side MOSFET $R_{\text{DS}}(\text{on})$
- $R_{\text{DS}}(\text{HS})$ = high-side MOSFET $R_{\text{DS}}(\text{on})$
- R_{DCR} = DC resistance of inductor
- t_{OFF} = off-time that 100% duty cycle operation begins (12)

7.3.14 Output Overvoltage Protection (OVP)

The TPS54A24 incorporates an output overvoltage protection (OVP) circuit to minimize output voltage overshoot. The OVP feature minimizes the overshoot by comparing the FB pin voltage to the OVP threshold. The OVP threshold is the same as the 108% PGOOD threshold. If the FB pin voltage is greater than the OVP threshold the high-side MOSFET is turned off preventing current from flowing to the output and minimizing output overshoot. When the high-side MOSFET turns off, the low-side MOSFET turns on and the current in the inductor discharges. The output voltage can overshoot the OVP threshold as the current in the inductor discharges to 0 A. When the FB voltage drops lower than the 106% PGOOD threshold, the high-side MOSFET is allowed to turn on at the next clock cycle.

7.3.15 Overcurrent Protection

The device is protected from overcurrent conditions by cycle-by-cycle current limiting on both the high-side MOSFET and the low-side MOSFET. In an extended overcurrent condition the device enters hiccup to reduce power dissipation. 图 35 shows the typical response with an overload on the output. At time (1) the high-side MOSFET peak current limit starts to limit the peak inductor current. At time (2) the low-side MOSFET forward current limit starts to cause the switching frequency to drop to prevent current runaway.

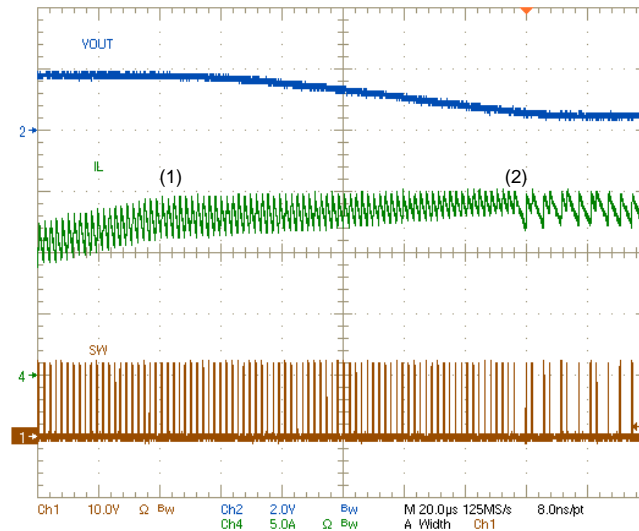
Feature Description (接下页)

图 35. Example Current Limit Waveform
7.3.15.1 High-Side MOSFET Overcurrent Protection

The device implements current mode control which uses the COMP pin voltage to control the turnoff of the high-side MOSFET and the turnon of the low-side MOSFET on a cycle-by-cycle basis. Each cycle the switch current and the current reference generated by the COMP pin voltage are compared, when the peak switch current intersects the current reference the high-side switch is turned off. The maximum peak switch current through the high-side MOSFET for overcurrent protection is done by limiting the current reference internally. If the peak current required to regulate the output is greater than the internal limit, the output voltage is pulled low and the error amplifier responds by driving the COMP pin high. The maximum COMP voltage is then clamped by an internal COMP clamp circuit. If the COMP voltage is clamped high for more than the hiccup wait time of 512 switching cycles, the device will shut down itself and restart after the hiccup time of 16384 cycles.

7.3.15.2 Low-Side MOSFET Overcurrent Protection

While the low-side MOSFET is turned on the current through it is monitored. During normal operation the low-side MOSFET sources current to the load. At the end of every clock cycle, the low-side MOSFET sourcing current is compared to the internally set low-side sourcing current limit. If the low-side sourcing current is exceeded the high-side MOSFET is not turned on and the low-side MOSFET stays on for the next cycle. The high-side MOSFET is turned on again when the low-side current is below the low-side sourcing current limit at the start of a cycle. The low-side sourcing current limit prevents current runaway.

The low-side MOSFET may also sink current from the load. If the low-side sinking current limit is exceeded the low-side MOSFET is turned off immediately for the rest of that clock cycle. In this scenario both MOSFETs are off until the start of the next cycle. If the low-side MOSFET turns off due to sinking current limit protection, the low-side MOSFET can only turn on again after the high-side MOSFET turns on then off or if the device enters BOOT UVLO.

7.4 Device Functional Modes

The EN pin and a VIN UVLO is used to control turn on and turn off of the TPS54A24. The device becomes active when $V_{(VIN)}$ exceeds the 4.1 V typical UVLO and when $V_{(EN)}$ exceeds 1.20 V typical. The EN pin has an internal current source to enable the output when the EN pin is left floating. If the EN pin is pulled low the device is put into a low quiescent current state.

8 Application and Implementation

注

Information in the following applications sections is not part of the TI component specification, and TI does not warrant its accuracy or completeness. TI's customers are responsible for determining suitability of components for their purposes. Customers should validate and test their design implementation to confirm system functionality.

8.1 Application Information

The TPS54A24 is a synchronous buck converter designed for 4.5 V to 17 V input and 10-A load. This procedure illustrates the design of a high-frequency switching regulator using ceramic output capacitors. Alternatively the WEBENCH[®] software can be used to generate a complete design. The WEBENCH[®] software uses an interactive design procedure and accesses a comprehensive database of components when generating a design. This section presents a simplified discussion of the design process.

8.2 Typical Application



图 36. TPS54A24 4.5-V to 17-V Input, 1.8-V Output Converter Application Schematic

8.2.1 Design Requirements

For this design example, use the parameters shown in 表 1.

表 1. Design Parameters

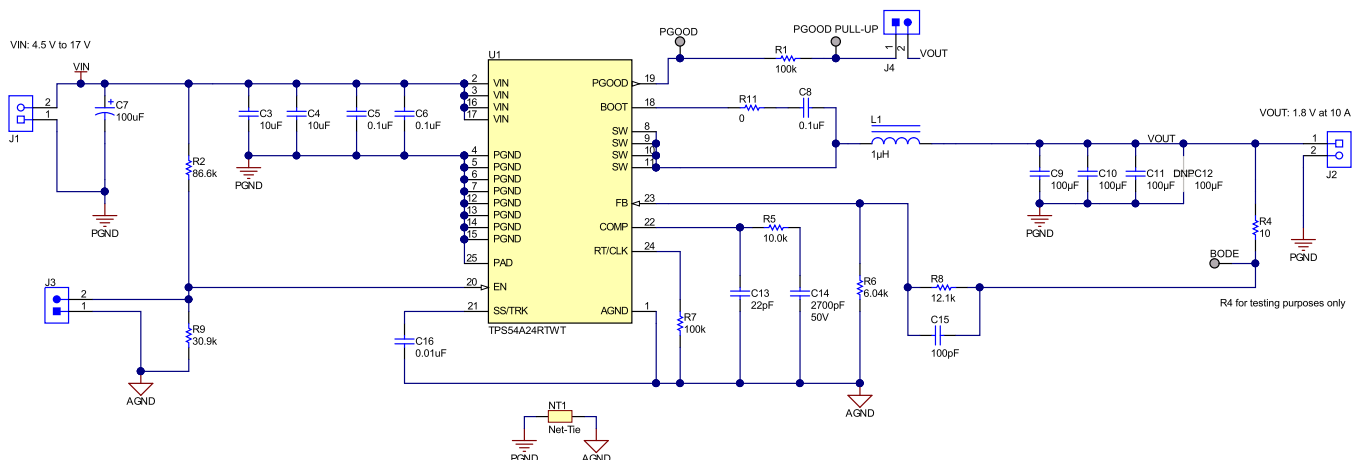
PARAMETER	EXAMPLE VALUE
Input voltage range (V_{IN})	4.5 to 17 V, 12 V nominal
Output voltage (V_{OUT})	1.8 V
Transient response	$\pm 4\%$, ± 72 mV
Output ripple voltage	0.5%, 9 mV
Output current rating (I_{OUT})	10 A
Operating frequency (f_{SW})	500 kHz

8.2.2 Detailed Design Procedure

8.2.2.1 Custom Design With WEBENCH® Tools

[Click here](#) to create a custom design using the TPS54A24 device with the WEBENCH® Power Designer.

1. Start by entering the input voltage (V_{IN}), output voltage (V_{OUT}), and output current (I_{OUT}) requirements.
2. Optimize the design for key parameters such as efficiency, footprint, and cost using the optimizer dial.
3. Compare the generated design with other possible solutions from Texas Instruments.

The WEBENCH Power Designer provides a customized schematic along with a list of materials with real-time pricing and component availability.

In most cases, these actions are available:

- Run electrical simulations to see important waveforms and circuit performance
- Run thermal simulations to understand board thermal performance
- Export customized schematic and layout into popular CAD formats
- Print PDF reports for the design, and share the design with colleagues

Get more information about WEBENCH tools at www.ti.com/WEBENCH.

8.2.2.2 Switching Frequency

The first step is to decide on a switching frequency for the converter. The TPS54A24 is capable of running from 200 kHz to 1.6 MHz. Typically the highest switching frequency possible is desired because it produces the smallest solution size. A high switching frequency allows for smaller inductors and output capacitors compared to a power supply that switches at a lower frequency. The main trade off made with selecting a higher switching frequency is extra switching power loss, which hurt the converter's efficiency.

The maximum switching frequency for a given application is limited by the minimum on-time of the converter and is estimated with [公式 13](#). Using a maximum minimum on-time of 150 ns for the TPS54A24 and 17 V maximum input voltage for this application, the maximum switching frequency is 706 kHz. The selected switching frequency must also consider the 10% tolerance of the switching frequency. A switching frequency of 500 kHz was selected for a good balance of solution size and efficiency. [公式 14](#) calculates R_7 (R_T) to be 97.6 k Ω . A standard 1% value of 100 k Ω was chosen in the design.

$$f_{SW}(\text{max}) = \frac{1}{t_{onmin}} \times \frac{V_{OUT}}{V_{IN}(\text{max})} \quad (13)$$

$$RT(\text{k}\Omega) = 58650 \times f_{SW}(\text{kHz})^{-1.028} \quad (14)$$

8.2.2.3 Output Inductor Selection

To calculate the value of the output inductor, use [公式 15](#). K_{IND} is a ratio that represents the amount of inductor ripple current relative to the maximum output current. The inductor ripple current is filtered by the output capacitor. Therefore, choosing high inductor ripple currents impacts the selection of the output capacitor since the output capacitor must have a ripple current rating equal to or greater than the inductor ripple current. Additionally with current mode control the sensed inductor current ripple is used in the PWM modulator. Choosing small inductor ripple currents can degrade the transient response performance or introduce jitter in the high-side MOSFET on-time. The inductor ripple, K_{IND} , is normally from 0.1 to 0.4 for the majority of applications giving a peak to peak ripple current range of 1 A to 4 A. For applications requiring operation near the minimum on-time, with on-times less than 200 ns, the target Iripple must be 2 A or larger for best performance. For other applications the target Iripple must be 1 A or larger.

For this design example, $K_{IND} = 0.3$ is used and the inductor value is calculated to be 1.07 μH . The nearest standard value 1 μH is selected. It is important that the RMS (Root Mean Square) current and saturation current ratings of the inductor not be exceeded. The RMS and peak inductor current can be found from [公式 17](#) and [公式 18](#). For this design, the RMS inductor current is 10 A, and the peak inductor current is 11.6 A. The chosen inductor is a 74437358010. It has a saturation current rating of 32.5 A and a RMS current rating of 14 A. The DC series resistance is 3.65 m Ω typical.

The current flowing through the inductor is the inductor ripple current plus the output current. During power up, faults or transient load conditions, the inductor current can increase above the calculated peak inductor current level calculated in 公式 18. In transient conditions, the inductor current can increase up to the switch current limit of the device. For this reason, the most conservative approach is to specify the ratings of the inductor based on the switch current limit rather than the steady-state peak inductor current.

$$L1 = \frac{V_{inmax} - V_{out}}{I_o \times K_{ind}} \times \frac{V_{out}}{V_{inmax} \times f_{sw}} \quad (15)$$

$$I_{ripple} = \frac{V_{inmax} - V_{out}}{L1} \times \frac{V_{out}}{V_{inmax} \times f_{sw}} \quad (16)$$

$$I_{Lrms} = \sqrt{I_o^2 + \frac{1}{12} \times \left(\frac{V_o \times (V_{inmax} - V_o)}{V_{inmax} \times L1 \times f_{sw}} \right)^2} \quad (17)$$

$$I_{Lpeak} = I_{out} + \frac{I_{ripple}}{2} \quad (18)$$

8.2.2.4 Output Capacitor

There are two primary considerations for selecting the value of the output capacitor. The output voltage ripple and how the regulator responds to a large change in load current. The output capacitance needs to be selected based on the more stringent of these two criteria.

The desired response to a large change in the load current is the first criteria and is typically the most stringent. A regulator does not respond immediately to a large, fast increase or decrease in load current. The output capacitor supplies or absorbs charge until the regulator responds to the load step. The control loop needs to sense the change in the output voltage then adjust the peak switch current in response to the change in load. The minimum output capacitance is selected based on an estimate of the loop bandwidth. Typically the loop bandwidth is near $f_{sw}/10$. 公式 19 estimates the minimum output capacitance necessary, where ΔI_{OUT} is the change in output current and ΔV_{OUT} is the allowable change in the output voltage.

For this example, the transient load response is specified as a 4% change in V_{OUT} for a load step of 5 A. Therefore, ΔI_{OUT} is 5 A and ΔV_{OUT} is 72 mV. Using this target gives a minimum capacitance of 221 μ F. This value does not take the ESR of the output capacitor into account in the output voltage change. For ceramic capacitors, the effect of the ESR can be small enough to be ignored. Aluminum electrolytic and tantalum capacitors have higher ESR that must be considered for load step response.

公式 20 calculates the minimum output capacitance needed to meet the output voltage ripple specification. Where f_{sw} is the switching frequency, V_{ripple} is the maximum allowable output voltage ripple, and I_{ripple} is the inductor ripple current. In this case, the target maximum output voltage ripple is 9 mV. Under this requirement, 公式 20 yields 89.4 μF .

$$C_{OUT} > \frac{\Delta I_{OUT}}{\Delta V_{OUT}} \times \frac{1}{2\pi \times \frac{f_{SW}}{10}} \quad (19)$$

$$C_o > \frac{1}{8 \times f_{sw}} \times \frac{1}{\frac{V_{ripple}}{I_{ripple}}}$$

where

- ΔI_{OUT} is the change in output current
 - ΔV_{OUT} is the allowable change in the output voltage
 - f_{sw} is the regulators switching frequency
- (20)

公式 21 calculates the maximum combined ESR the output capacitors can have to meet the output voltage ripple specification, and this shows the ESR should be less than 3 m Ω . In this case ceramic capacitors are used, and the combined ESR of the ceramic capacitors in parallel is much less than 3 m Ω . Capacitors also have limits to the amount of ripple current they can handle without producing excess heat and failing. An output capacitor that can support the inductor ripple current must be specified. The capacitor datasheet specifies the RMS value of the maximum ripple current. 公式 22 can be used to calculate the RMS ripple current the output capacitor needs to support. For this application, 公式 22 yields 930 mA and ceramic capacitors typically have a ripple current rating much higher than this.

$$Resr < \frac{V_{ripple}}{I_{ripple}} \quad (21)$$

$$I_{corms} = \frac{V_{out} \times (V_{inmax} - V_{out})}{\sqrt{12} \times V_{inmax} \times L1 \times f_{sw}} \quad (22)$$

Select X5R and X7R ceramic dielectrics or equivalent for power regulator capacitors because they have a high capacitance to volume ratio and are fairly stable over temperature. The output capacitor must also be selected with the DC bias and AC voltage derating taken into account. The derated capacitance value of a ceramic capacitor due to DC voltage bias and AC RMS voltage is usually found on the capacitor manufacturer's website. For this application example, three 100 μF 6.3 V 1210 X7S ceramic capacitors each with 2 m Ω of ESR are used. The estimated capacitance after derating using the capacitor manufacturer's website is 64 μF each. With three parallel capacitors the total effective output capacitance is 192 μF and the ESR is 0.7 m Ω . Although this is below the estimated value of 221 μF to meet the load step response requirement, bench evaluation showed this amount of capacitance to be sufficient.

8.2.2.5 Input Capacitor

The TPS54A24 requires input decoupling ceramic capacitors type X5R, X7R or similar from VIN to PGND placed as close as possible to the IC. A total of at least 10 μF of capacitance is required and some applications may require a bulk capacitance. At least 1 μF of bypass capacitance is recommended near both VIN pins to minimize the input voltage ripple. A 0.1- μF to 1- μF capacitor must be placed by both VIN pins 2-3 and 16-17 to provide high frequency bypass to reduce the high frequency overshoot and undershoot on VIN and SW pins. The voltage rating of the input capacitor must be greater than the maximum input voltage. The capacitor must also have a ripple current rating greater than the maximum RMS input current of the TPS54A24. The RMS input current can be calculated using 公式 23.

For this example design, a ceramic capacitor with at least a 25-V voltage rating is required to support the maximum input voltage. Two 10- μF , 1210, X7R, 25-V and two 0.1- μF , 0603, X7R 25-V capacitors in parallel has been selected to be placed on both sides of the TPS54A24 near both VIN pins to PGND pins. Based on the capacitor manufacturer's website, the total ceramic input capacitance derates to 14 μF at the nominal input voltage of 12 V. A 100- μF bulk capacitance is also used in this circuit to bypass long leads when connected a lab bench top power supply.

The input capacitance value determines the input ripple voltage of the regulator. The input voltage ripple can be calculated using 公式 24. The maximum input ripple occurs when operating nearest to 50% duty cycle. Using the nominal design example values of $I_{\text{outmax}} = 10\text{ A}$, $C_{\text{IN}} = 14\ \mu\text{F}$, and $f_{\text{SW}} = 500\text{ kHz}$, the input voltage ripple with the 12 V nominal input is 150 mV and the RMS input ripple current with the 4.5 V minimum input is 4.9 A.

$$I_{\text{cirms}} = I_{\text{out}} \times \sqrt{\frac{V_{\text{out}}}{V_{\text{inmin}}} \times \frac{(V_{\text{inmin}} - V_{\text{out}})}{V_{\text{inmin}}}} \quad (23)$$

$$\Delta V_{\text{in}} = \frac{I_{\text{outmax}} \times \left(1 - \frac{V_{\text{out}}}{V_{\text{in}}}\right) \times \frac{V_{\text{out}}}{V_{\text{in}}}}{C_{\text{in}} \times f_{\text{SW}}} \quad (24)$$

8.2.2.6 Output Voltage Resistors Selection

The output voltage is set with a resistor divider created by R8 (R_{FBT}) and R6 (R_{FBB}) from the output node to the FB pin. It is recommended to use 1% tolerance or better resistors. For this example design, 6.04 k Ω was selected for R8. Using 公式 25, R6 is calculated as 12.08 k Ω . The nearest standard 1% resistor is 12.1 k Ω .

$$R_{\text{FBT}} = R_{\text{FBB}} \times \left(\frac{V_{\text{OUT}}}{V_{\text{REF}}} - 1\right) \quad (25)$$

8.2.2.7 Soft-Start Capacitor Selection

The soft-start capacitor ($C_{\text{SS}} = C16$) determines the amount of time it takes for the output voltage to reach its nominal programmed value during power up. This is useful if a load requires a controlled voltage slew rate. This is also used if the output capacitance is very large and would require large amounts of current to quickly charge the capacitor to the output voltage level. The large currents necessary to charge the capacitor may make the TPS54A24 reach its current limit or cause the input voltage rail to sag due excessive current draw from the input power supply. Limiting the output voltage slew rate solves both of these problems. The soft-start capacitor value can be calculated using 公式 26. For the example circuit, the soft-start time is not critical because the output capacitor value of $3 \times 100\ \mu\text{F}$ does not require much current to charge to 1.8 V. The example circuit has the soft-start time set to an arbitrary value of 1.2 ms, which requires a 0.01- μF capacitor. With this soft-start time the current required to charge the output capacitors is only 0.18 A.

$$C_{\text{SS}} (\text{nF}) = \frac{I_{\text{SS}} (\mu\text{A}) \times t_{\text{SS}} (\text{ms})}{V_{\text{REF}} (\text{V})} = 8.3 \times t_{\text{SS}} (\text{ms}) \quad (26)$$

8.2.2.8 Undervoltage Lockout Setpoint

The undervoltage lockout (UVLO) is adjusted using the external voltage divider network of R2 (R_{ENT}) and R9 (R_{ENB}). The UVLO has two thresholds; one for power up when the input voltage is rising and one for power down or brownouts when the input voltage is falling. For the example design, the supply must turn on and start switching once the input voltage increases above 4.5 V (UVLO start or enable). After the regulator starts switching, it continues to do so until the input voltage falls below 4.0 V (UVLO stop or disable). 公式 2 and 公式 3 can be used to calculate the values for the upper and lower resistor values. For the voltages specified, the standard resistor value used for R_{ENT} is 86.6 k Ω and for R_{ENB} is 30.9 k Ω .

8.2.2.9 Bootstrap Capacitor Selection

A 0.1- μF ceramic capacitor must be connected between the BOOT to SW pin for proper operation. A 1 Ω to 5.6 Ω resistor can be added in series with the BOOT capacitor to slow down the turn on of the high-side MOSFET. This can reduce voltage spikes on the SW node with the trade off of more power loss and lower efficiency.

8.2.2.10 PGOOD Pullup Resistor

A 100-k Ω resistor is used to pull up the power good signal when FB conditions are met. The pullup voltage source must be less than the 6.5 V absolute maximum of the PGOOD pin.

8.2.2.11 Compensation

There are several methods used to compensate DC/DC regulators. The method presented here is easy to calculate and ignores the effects of the slope compensation internal to the device. Because the slope compensation is ignored, the actual cross-over frequency will usually be lower than the cross-over frequency used in the calculations. This method assumes the cross-over frequency is between the modulator pole and the ESR zero and the ESR zero is at least 10 times greater the modulator pole. This is the case when using low ESR output capacitors. Use the WEBENCH[®] software for more accurate loop compensation. These tools include a more comprehensive model of the control loop.

To get started, the modulator pole, f_{pmod} , and the ESR zero, f_{zmod} must be calculated using 公式 27 and 公式 28. For C_{OUT} , use a derated value of 192 μF and an ESR of 0.7 m Ω . Use equations 公式 29 and 公式 30, to estimate a starting point for the crossover frequency, f_{co} , to design the compensation. For the example design, f_{pmod} is 7.2 kHz and f_{zmod} is 1940 kHz. 公式 29 is the geometric mean of the modulator pole and the ESR zero. 公式 30 is the mean of modulator pole and one half the switching frequency. 公式 29 yields 118 kHz and 公式 30 yields 42.4 kHz. Use the lower value of 公式 29 or 公式 30 for an initial crossover frequency. Next, the compensation components are calculated. A resistor in series with a capacitor is used to create a compensating zero. A capacitor in parallel to these two components forms the compensating pole.

$$f_{\text{pmod}} = \frac{I_{\text{outmax}}}{2 \times \pi \times V_{\text{out}} \times C_{\text{out}}} \quad (27)$$

$$f_{\text{zmod}} = \frac{1}{2 \times \pi \times R_{\text{esr}} \times C_{\text{out}}} \quad (28)$$

$$f_{\text{co}} = \sqrt{f_{\text{pmod}} \times f_{\text{zmod}}} \quad (29)$$

$$f_{\text{co}} = \sqrt{f_{\text{pmod}} \times \frac{f_{\text{sw}}}{2}} \quad (30)$$

To determine the compensation resistor ($R_{\text{COMP}} = R5$) use 公式 31. R_{COMP} is calculated to be 5.26 k Ω and the closest standard value 5.23 k Ω . Use 公式 32 to set the compensation zero to the modulator pole frequency. 公式 32 yields 2120 pF for compensating capacitor ($C_{\text{COMP}} = C14$); round this up to the next standard value of 2200 pF.

$$R_{\text{COMP}} = \left(\frac{2 \times \pi \times f_{\text{co}} \times C_{\text{OUT}}}{g_{\text{mPS}}} \right) \times \left(\frac{V_{\text{OUT}}}{V_{\text{REF}} \times g_{\text{mEA}}} \right)$$

where

- Power stage transconductance, $g_{\text{mPS}} = 17 \text{ A/V}$
- $V_{\text{OUT}} = 1.8 \text{ V}$
- $V_{\text{REF}} = 0.6 \text{ V}$
- Error amplifier transconductance, $g_{\text{mEA}} = 1100 \mu\text{A/V}$ (31)

$$C_{\text{COMP}} = \frac{1}{2 \times \pi \times R_{\text{COMP}} \times f_{\text{PMOD}}} \quad (32)$$

A compensation pole is implemented using an additional capacitor ($C_{HF} = C13$) in parallel with the series combination of R_{COMP} and C_{COMP} . This capacitor is recommended to help filter any noise that may couple to the COMP voltage signal. Use the larger value of [公式 33](#) and [公式 34](#) to calculate the C_{HF} and to set the compensation pole. C_{HF} is calculated to be the largest of 16 pF and 112 pF. Round this down to the next standard value of 100 pF.

$$C_{HF} = \frac{C_{OUT} \times R_{ESR}}{R_{COMP}} \quad (33)$$

$$C_{HF} = \frac{1}{\pi \times R_{COMP} \times f_{SW}} \quad (34)$$

Type III compensation can be used by adding the feed forward capacitor ($C_{FF} = C15$) in parallel with the upper feedback resistor. Type III compensation adds phase boost above what is possible from type II compensation because it places an additional zero/pole pair. The zero/pole pair is not independent. As a result once the zero location is chosen, the pole is fixed as well. The zero is placed at 1/2 the f_{SW} by calculating the value of C_{FF} with [公式 35](#). The calculated value is 53 pF — round this down to the closest standard value of 47 pF. It is possible to use larger feedforward capacitors to further improve the transient response but take care to ensure there is a minimum of -10 dB gain margin at 1/2 the f_{SW} in all operating conditions. The feedforward capacitor injects noise on the output into the FB pin and this added noise can result in more jitter at the switching node. To little gain margin can cause a repeated wide and narrow pulse behavior.

(35)

The initial compensation based on these calculations is $R_{COMP} = 5.23 \text{ k}\Omega$, $C_{COMP} = 2200 \text{ pF}$, $C_{HF} = 100 \text{ pF}$ and $C_{FF} = 47 \text{ pF}$. These values yield a stable design but after testing the real circuit these values were changed to target a higher crossover frequency to improve transient response performance. The crossover frequency is increased by increasing the value of R5 and decreasing the value of the compensation capacitors. The final values used in this example are $R_{COMP} = 10.0 \text{ k}\Omega$, $C_{COMP} = 2700 \text{ pF}$, $C_{HF} = 22 \text{ pF}$ and $C_{FF} = 100 \text{ pF}$.

8.2.3 Application Curves

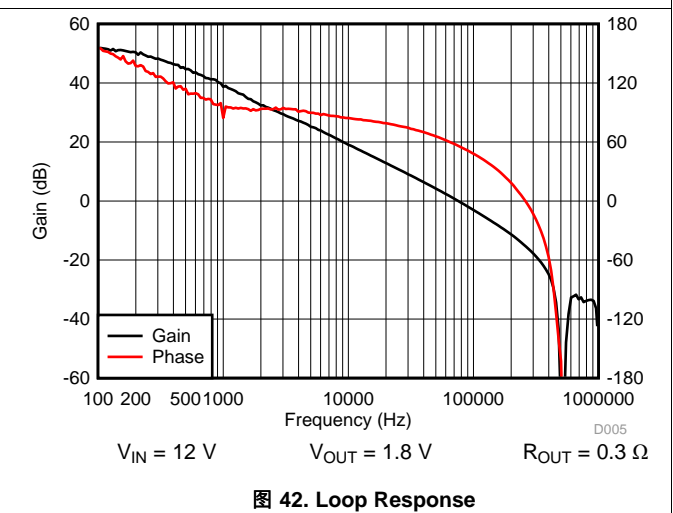
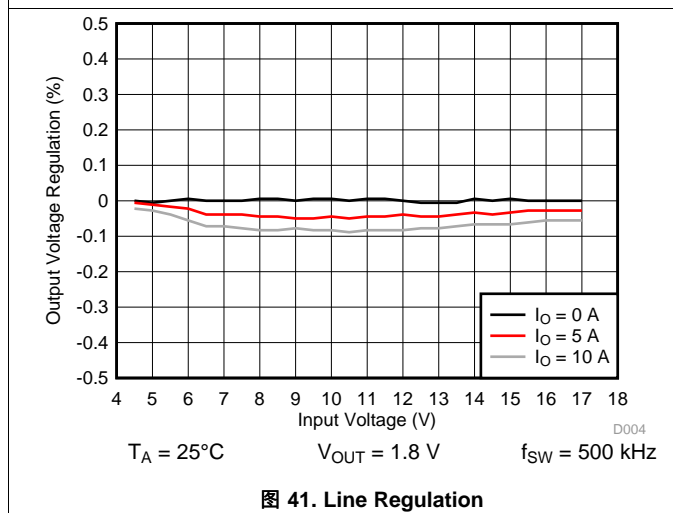
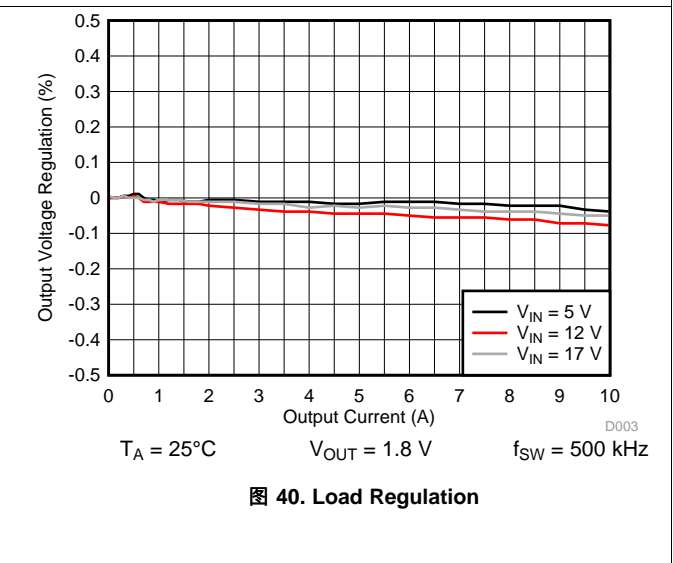
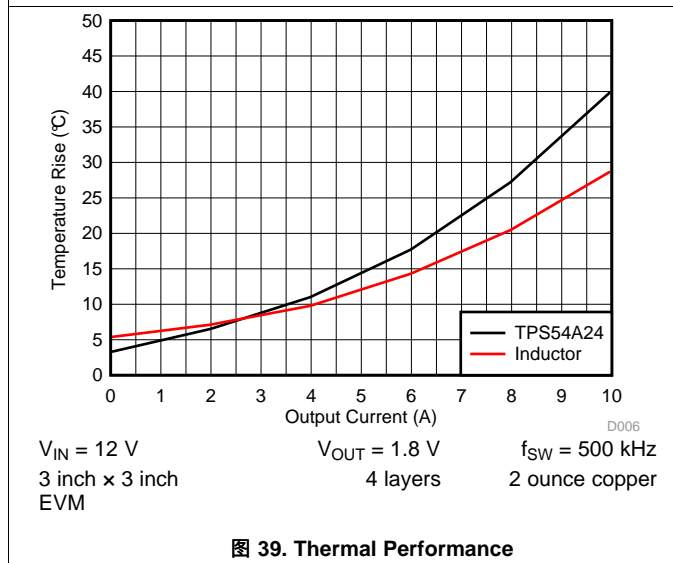
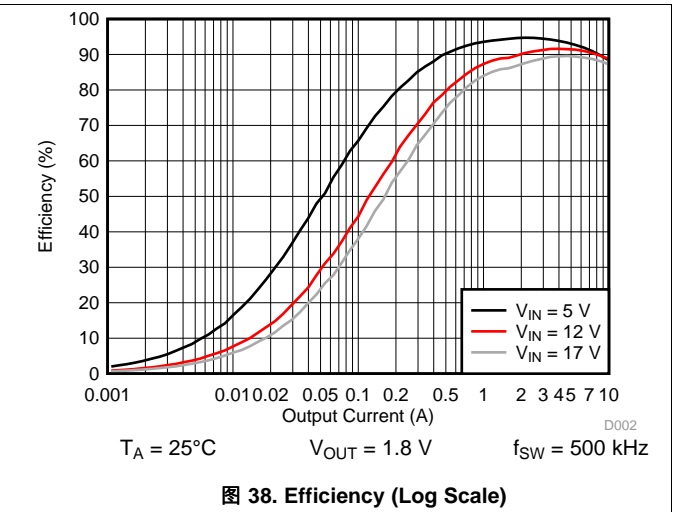
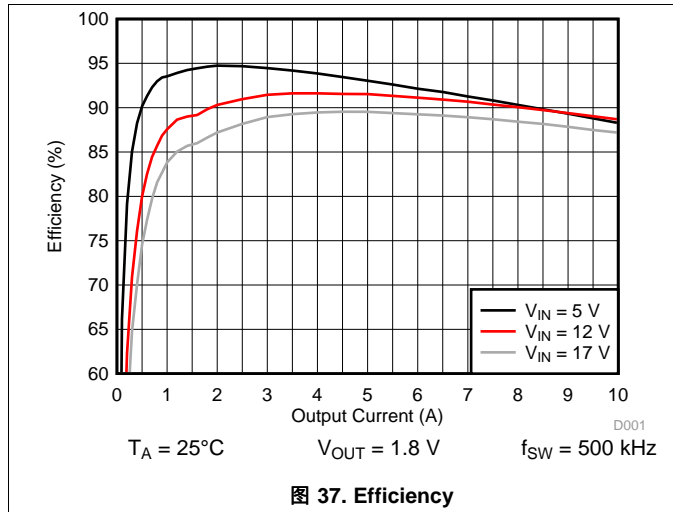



图 43. Transient Response



图 44. Output Ripple, No Load

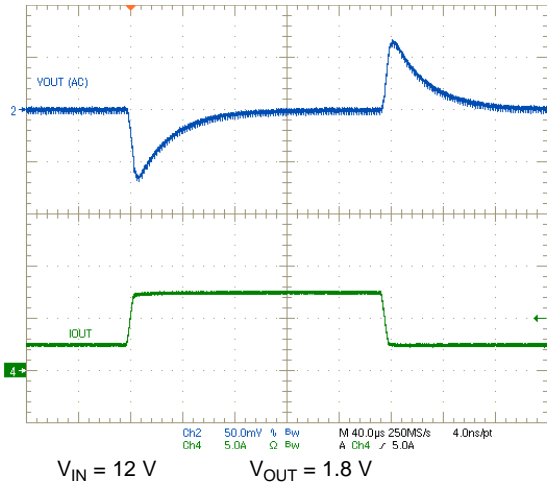

图 45. Output Ripple, 10-A Load

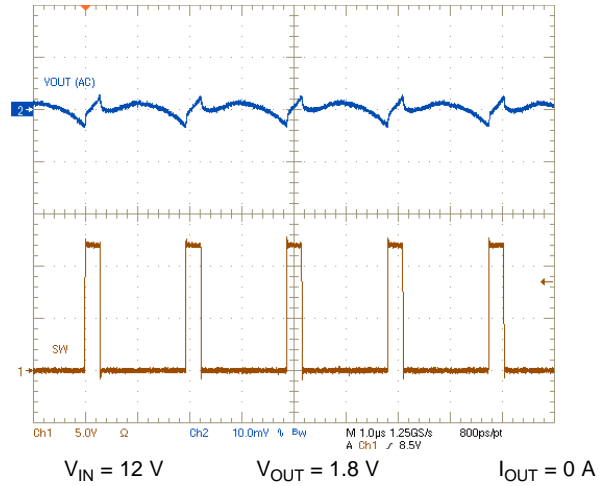

图 46. Input Ripple, No Load

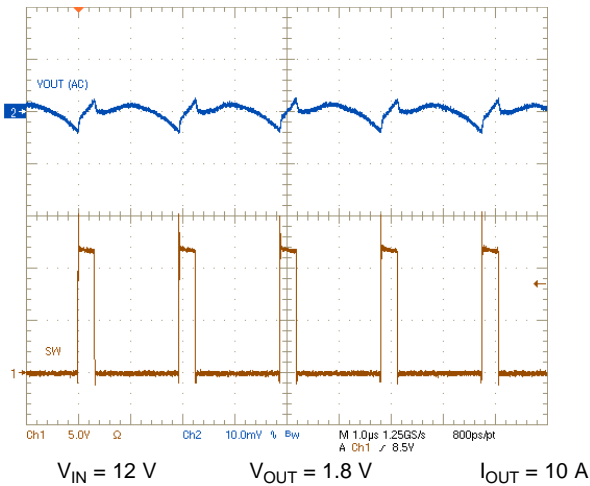

图 47. Input Ripple, 10-A Load

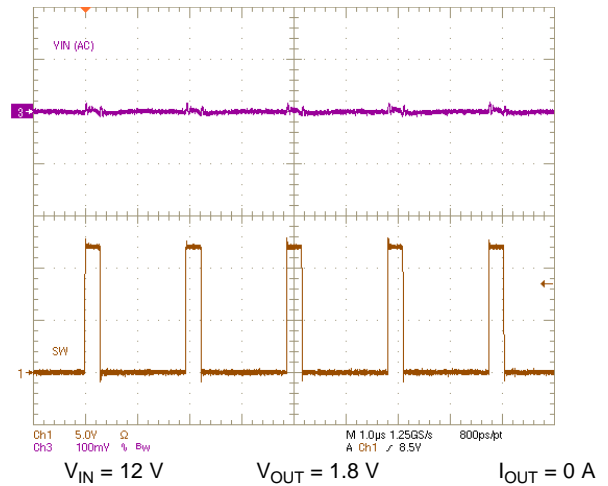

图 48. V_{IN} Start-up

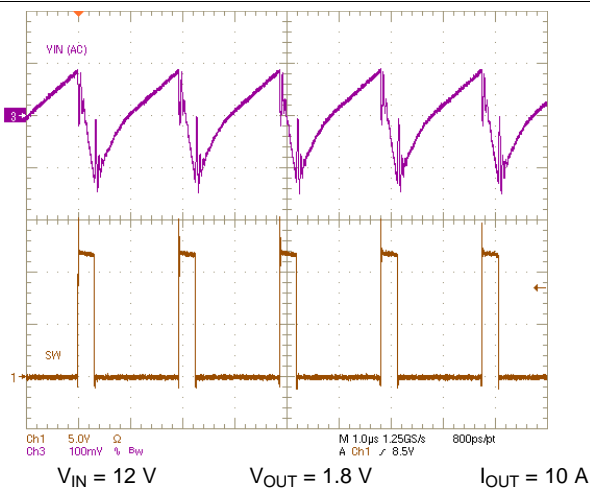

图 49. V_{IN} Shutdown

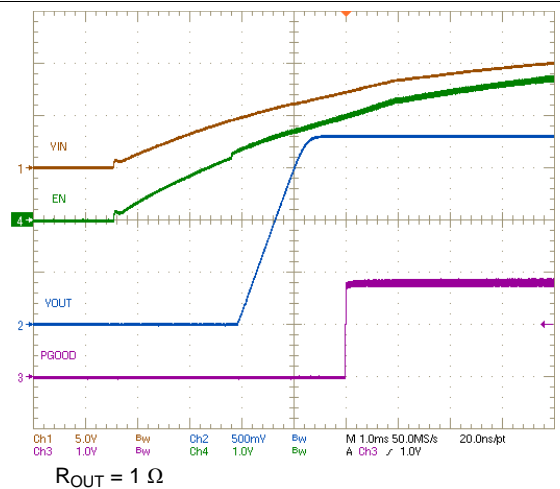

图 50. EN Start-up

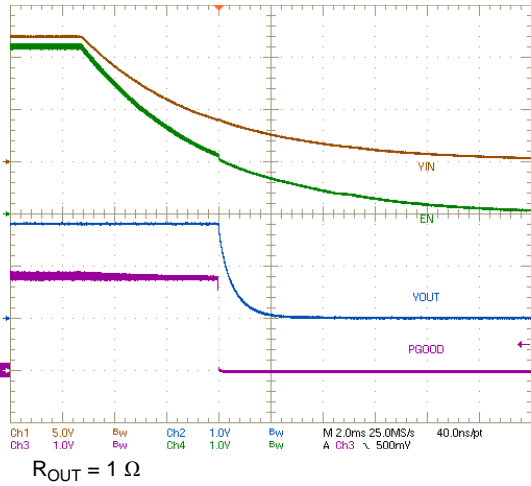

图 51. EN Shutdown

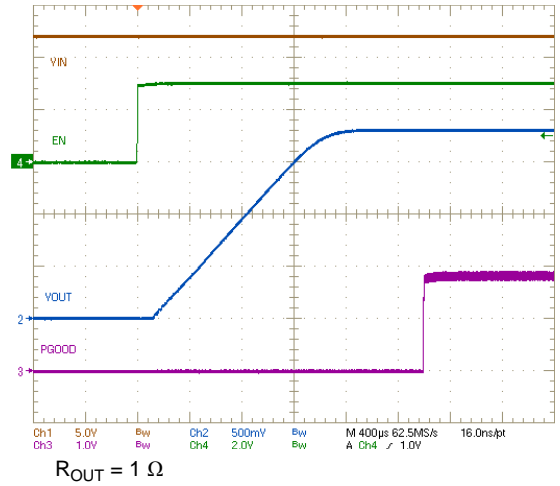

图 52. EN Start-up With Prebiased Output

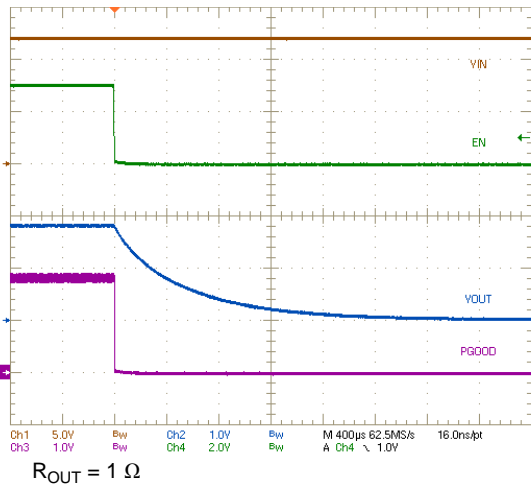

图 53. Output Short-Circuit Response

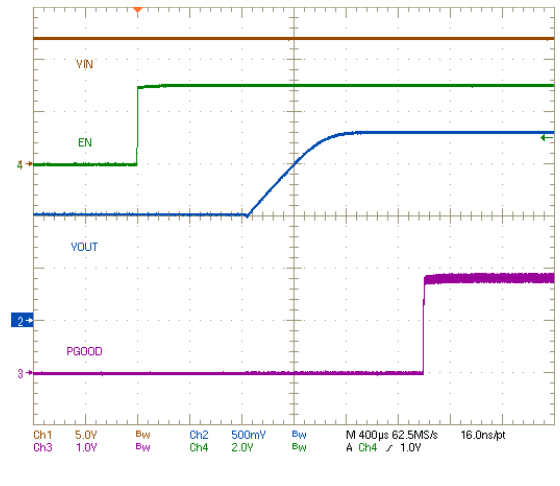

图 54. Hiccup Current Limit

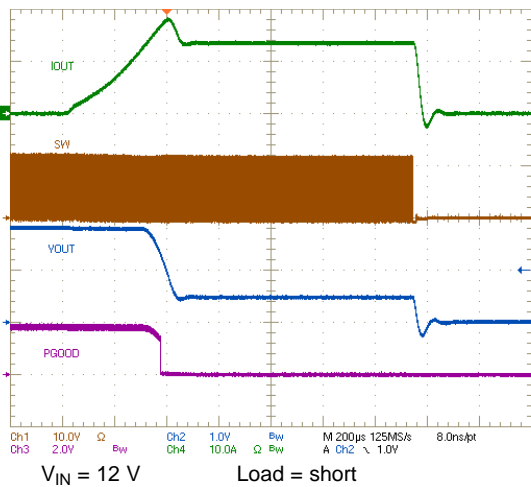

图 55. Hiccup Recovery

9 Power Supply Recommendations

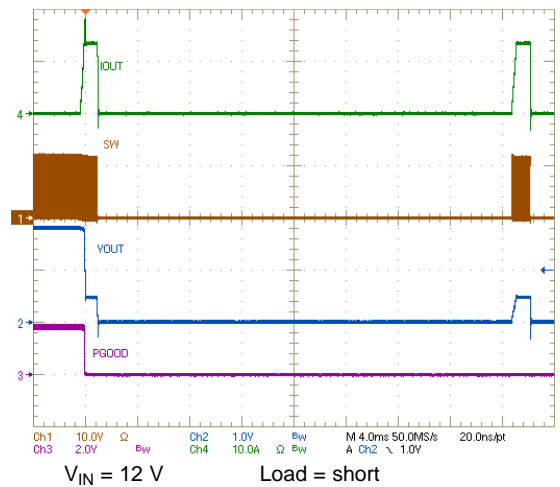
The TPS54A24 is designed to be powered by a well-regulated DC voltage between 4.5 and 17 V. The TPS54A24 is a buck converter so the input supply voltage must be greater than the desired output voltage to regulate the output voltage to the desired value. If the input supply voltage is not high enough the output voltage begins to drop. Input supply current must be appropriate for the desired output current.

10 Layout

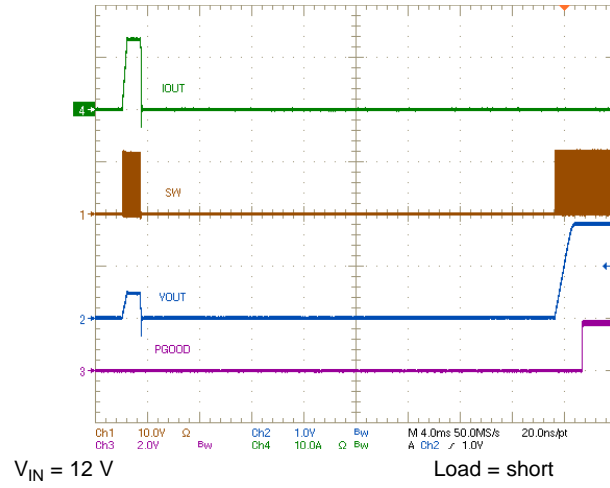
10.1 Layout Guidelines

- VIN and PGND traces must be as wide as possible to reduce trace impedance and improve heat dissipation.
- At least 1 μF of input capacitance is required on both VIN pins of the IC and must be placed as close as possible to the IC. The input capacitors must connect directly to the adjacent PGND pins.
- Connect the PGND pins on both sides of the IC to the thermal pad with a trace as wide as possible to reduce trace impedance and improve heat dissipation.
- The PGND trace between the output capacitor and the PGND pin must be as wide as possible to minimize its trace impedance.
- Provide sufficient vias for the input capacitor and output capacitor.
- Keep the SW trace as physically short and wide as practical to minimize radiated emissions.
- Minimize the length of the trace connected to the BOOT pin and the BOOT capacitor to minimize radiated emissions.
- Connect a separate VOUT path to the upper feedback resistor.
- Place voltage feedback loop away from the high-voltage switching trace. It is preferable to use ground copper near it as a shield.
- The trace connected to the FB node must be as small as possible to avoid noise coupling.
- Place components connected to the RT/CLK, FB, COMP and SS/TRK pins as close to the IC as possible and minimize traces connected to these pins to avoid noise coupling.
- AGND must be connected to PGND on the PCB. Connect AGND to PGND in a region away from switching currents.

10.2 Layout Example

图 56 through 图 59 shows an example PCB layout and the following list provides a description of each layer.

- The top layer has all components and the main traces for VIN, SW, VOUT and PGND. Both VIN pins are bypassed with two input capacitors placed as close as possible to the IC and are connected directly to the adjacent PGND pins. Multiple vias are placed near the input and output capacitors. The Net Tie (NT) connects AGND to PGND near CIN4.
- Midlayer 1 has a solid PGND plane to aid with thermal performance. The other trace on this layer to connect the PGOOD pin to the pullup resistor.
- Midlayer 2 has a wide trace connecting both VIN pins of the IC. It is also used to route the BOOT-SW capacitor (CBT) to the SW node. It also has a parallel trace for VOUT to minimize trace resistance. The rest of this layer is covered with PGND.
- The bottom layer has the trace connecting the FB resistor divider to VOUT at the point of regulation. PGND is filled into the rest of this layer to aid with thermal performance.

Layout Example (接下一页)



图 56. TPS54A24 Layout Top



图 57. TPS54A24 Layout Midlayer 1

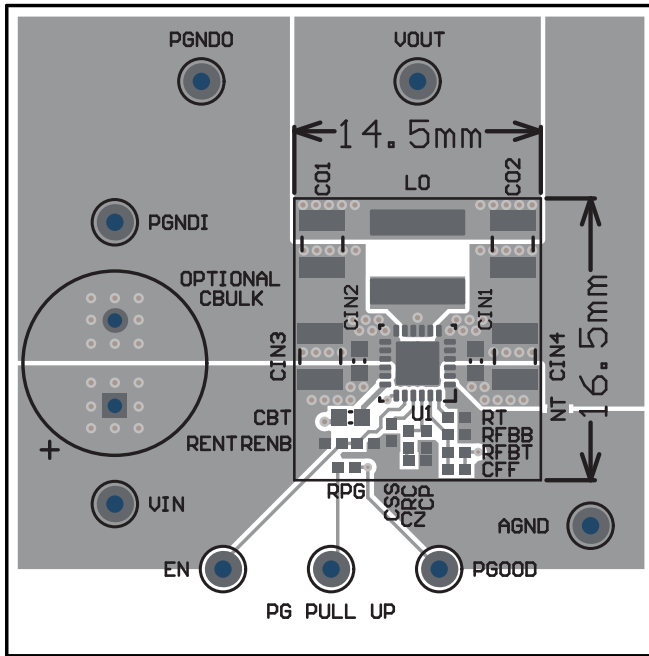

图 58. TPS54A24 Layout Midlayer 2

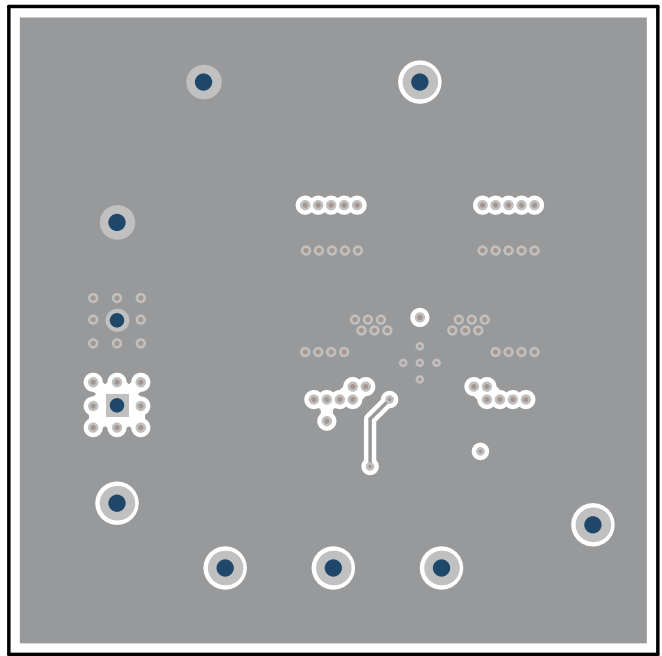

图 59. TPS54A24 Layout Bottom

11 器件和文档支持

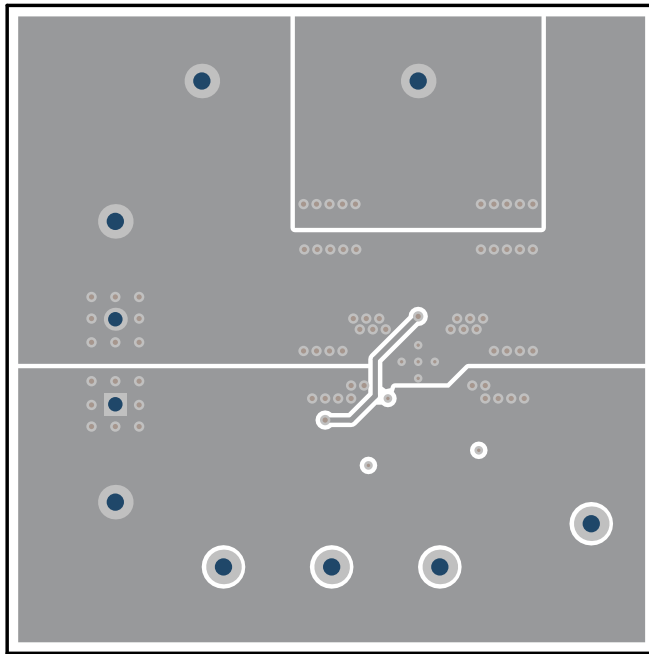
11.1 器件支持

11.1.1 开发支持

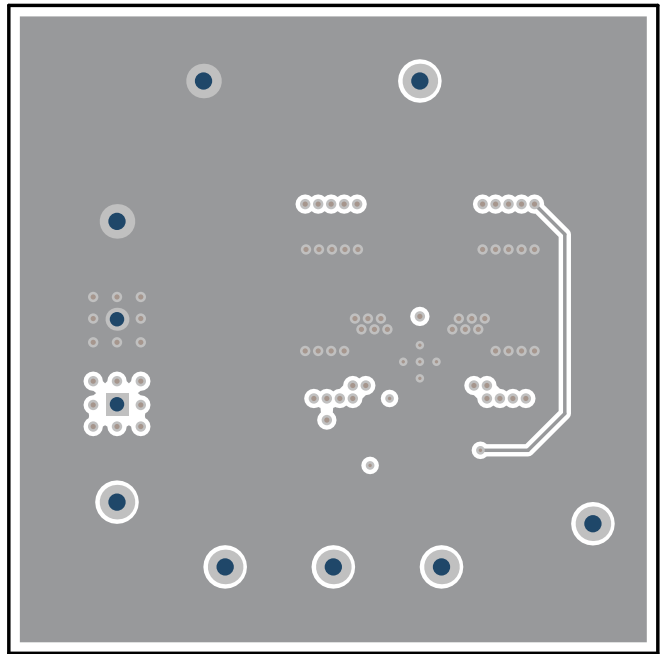
11.1.1.1 使用 **WEBENCH®** 工具创建定制设计

单击[此处](#)，以使用 TPS54A24 器件并借助 WEBENCH® 电源设计器进行定制设计。

1. 首先输入输入电压 (V_{IN})、输出电压 (V_{OUT}) 和输出电流 (I_{OUT}) 要求。
2. 使用优化器拨盘优化该设计的关键参数，如效率、尺寸和成本。
3. 将生成的设计与德州仪器 (TI) 的其他可行的解决方案进行比较。

WEBENCH 电源设计器可提供定制原理图以及罗列实时价格和组件供货情况的物料清单。

在多数情况下，可执行以下操作：

- 运行电气仿真，观察重要波形以及电路性能
- 运行热性能仿真，了解电路板热性能
- 将定制原理图和布局方案以常用 CAD 格式导出
- 打印设计方案的 PDF 报告并与同事共享

有关 WEBENCH 工具的详细信息，请访问 www.ti.com.cn/WEBENCH。

11.2 接收文档更新通知

要接收文档更新通知，请导航至 TI.com.cn 上的器件产品文件夹。单击右上角的 *通知我* 进行注册，即可每周接收产品信息更改摘要。有关更改的详细信息，请查看任何已修订文档中包含的修订历史记录。

11.3 社区资源

The following links connect to TI community resources. Linked contents are provided "AS IS" by the respective contributors. They do not constitute TI specifications and do not necessarily reflect TI's views; see TI's [Terms of Use](#).

TI E2E™ Online Community *TI's Engineer-to-Engineer (E2E) Community*. Created to foster collaboration among engineers. At e2e.ti.com, you can ask questions, share knowledge, explore ideas and help solve problems with fellow engineers.

Design Support *TI's Design Support* Quickly find helpful E2E forums along with design support tools and contact information for technical support.

11.4 商标

E2E is a trademark of Texas Instruments.

WEBENCH is a registered trademark of Texas Instruments.

All other trademarks are the property of their respective owners.

11.5 静电放电警告



这些装置包含有限的内置 ESD 保护。存储或装卸时，应将导线一起截短或将装置放置于导电泡棉中，以防止 MOS 门极遭受静电损伤。

11.6 Glossary

SLYZ022 — *TI Glossary*.

This glossary lists and explains terms, acronyms, and definitions.

12 机械、封装和可订购信息

以下页面包含机械、封装和可订购信息。这些信息是指定器件的最新可用数据。数据如有变更，恕不另行通知，且不会对此文档进行修订。如需获取此数据表的浏览器版本，请查阅左侧的导航栏。

PACKAGING INFORMATION

Orderable Device	Status (1)	Package Type	Package Drawing	Pins	Package Qty	Eco Plan (2)	Lead finish/ Ball material (6)	MSL Peak Temp (3)	Op Temp (°C)	Device Marking (4/5)	Samples
TPS54A24RTWR	ACTIVE	WQFN	RTW	24	3000	RoHS & Green	NIPDAU	Level-2-260C-1 YEAR	-40 to 150	S54A24	Samples

(1) The marketing status values are defined as follows:

ACTIVE: Product device recommended for new designs.

LIFEBUY: TI has announced that the device will be discontinued, and a lifetime-buy period is in effect.

NRND: Not recommended for new designs. Device is in production to support existing customers, but TI does not recommend using this part in a new design.

PREVIEW: Device has been announced but is not in production. Samples may or may not be available.

OBSOLETE: TI has discontinued the production of the device.

(2) **RoHS:** TI defines "RoHS" to mean semiconductor products that are compliant with the current EU RoHS requirements for all 10 RoHS substances, including the requirement that RoHS substance do not exceed 0.1% by weight in homogeneous materials. Where designed to be soldered at high temperatures, "RoHS" products are suitable for use in specified lead-free processes. TI may reference these types of products as "Pb-Free".

RoHS Exempt: TI defines "RoHS Exempt" to mean products that contain lead but are compliant with EU RoHS pursuant to a specific EU RoHS exemption.

Green: TI defines "Green" to mean the content of Chlorine (Cl) and Bromine (Br) based flame retardants meet JS709B low halogen requirements of <=1000ppm threshold. Antimony trioxide based flame retardants must also meet the <=1000ppm threshold requirement.

(3) MSL, Peak Temp. - The Moisture Sensitivity Level rating according to the JEDEC industry standard classifications, and peak solder temperature.

(4) There may be additional marking, which relates to the logo, the lot trace code information, or the environmental category on the device.

(5) Multiple Device Markings will be inside parentheses. Only one Device Marking contained in parentheses and separated by a "-" will appear on a device. If a line is indented then it is a continuation of the previous line and the two combined represent the entire Device Marking for that device.

(6) Lead finish/Ball material - Orderable Devices may have multiple material finish options. Finish options are separated by a vertical ruled line. Lead finish/Ball material values may wrap to two lines if the finish value exceeds the maximum column width.

Important Information and Disclaimer:The information provided on this page represents TI's knowledge and belief as of the date that it is provided. TI bases its knowledge and belief on information provided by third parties, and makes no representation or warranty as to the accuracy of such information. Efforts are underway to better integrate information from third parties. TI has taken and continues to take reasonable steps to provide representative and accurate information but may not have conducted destructive testing or chemical analysis on incoming materials and chemicals. TI and TI suppliers consider certain information to be proprietary, and thus CAS numbers and other limited information may not be available for release.

In no event shall TI's liability arising out of such information exceed the total purchase price of the TI part(s) at issue in this document sold by TI to Customer on an annual basis.

GENERIC PACKAGE VIEW

RTW 24

WQFN - 0.8 mm max height

4 x 4, 0.5 mm pitch

PLASTIC QUAD FLATPACK - NO LEAD

This image is a representation of the package family, actual package may vary.
Refer to the product data sheet for package details.

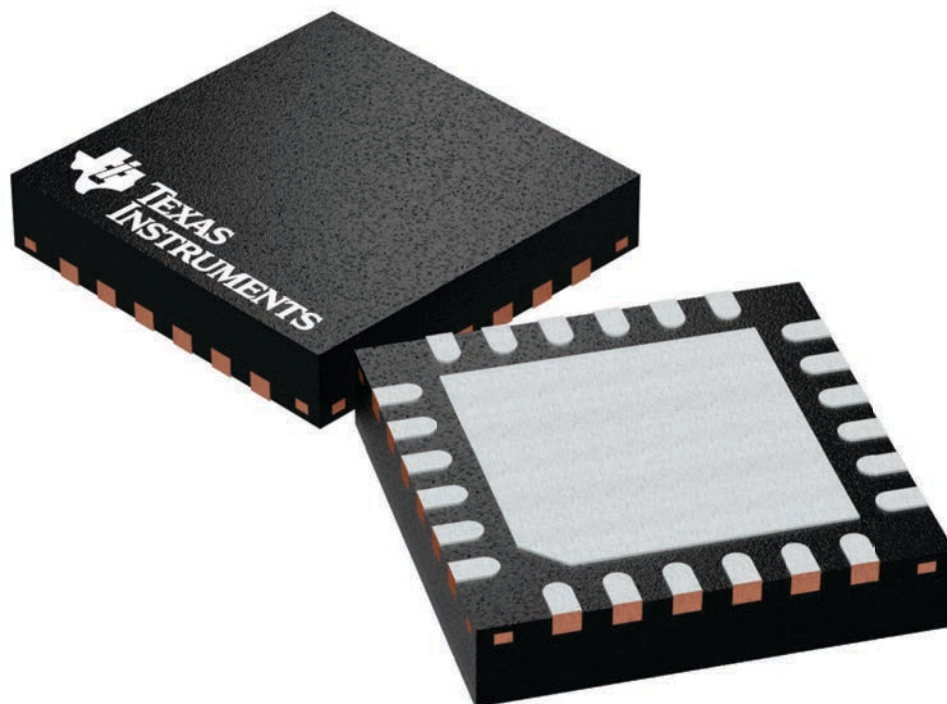

4224801/A

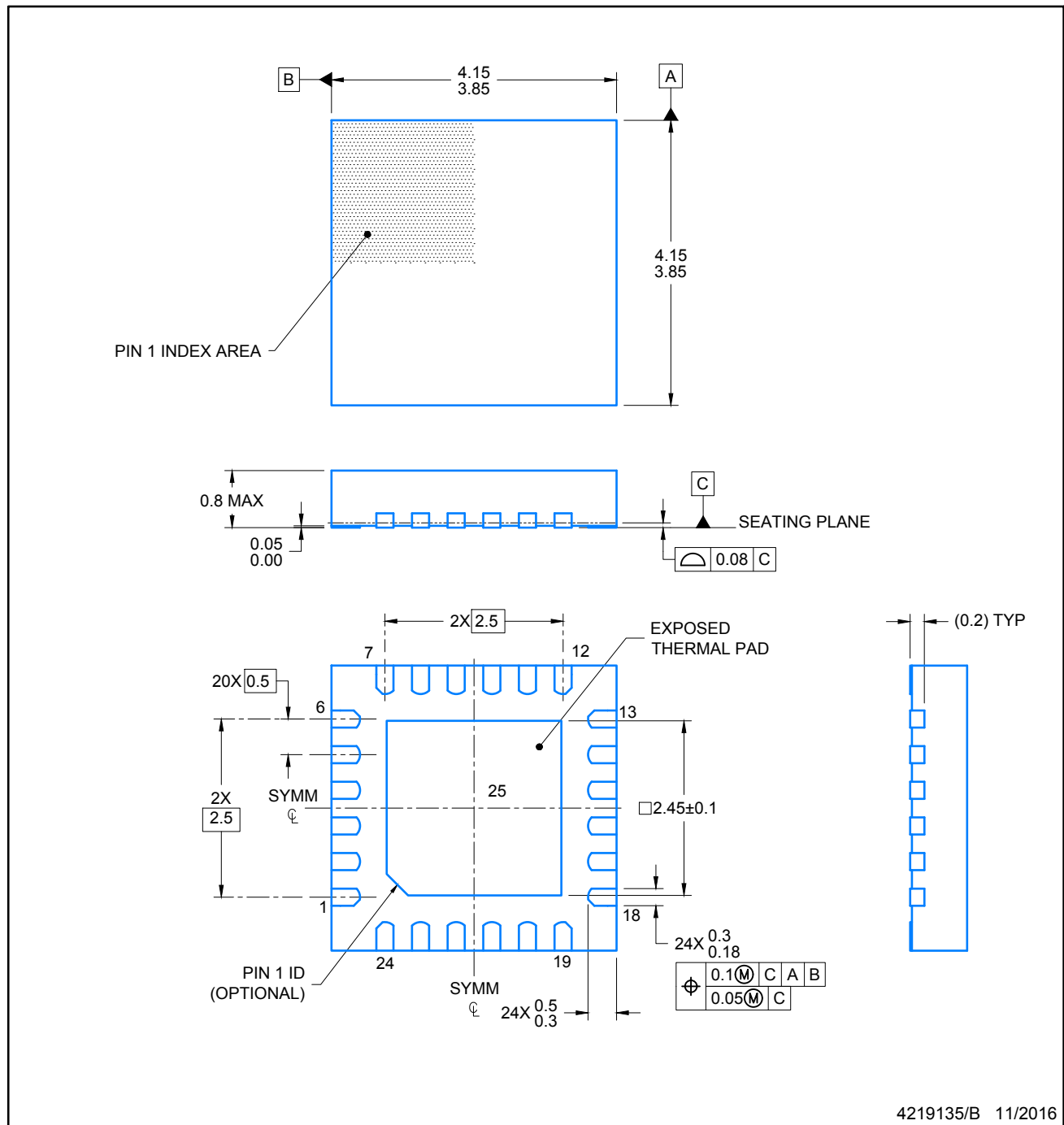

4219135/B 11/2016

NOTES:

1. All linear dimensions are in millimeters. Any dimensions in parenthesis are for reference only. Dimensioning and tolerancing per ASME Y14.5M.
2. This drawing is subject to change without notice.

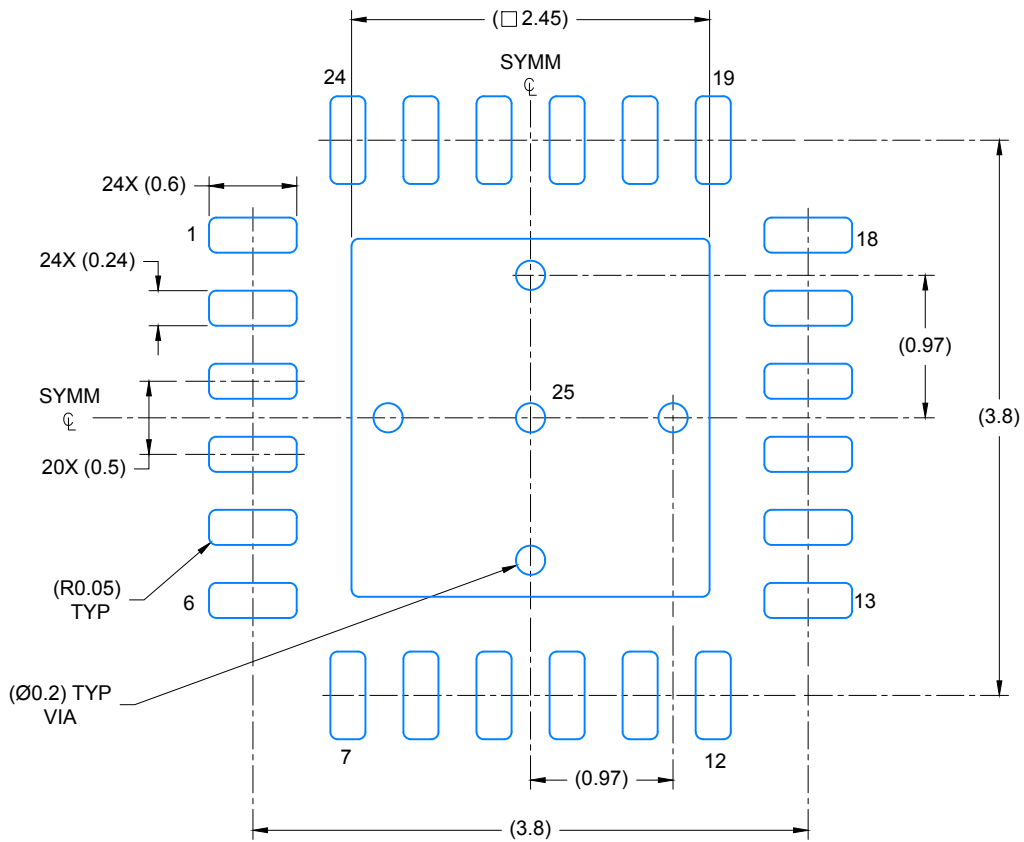

LAND PATTERN EXAMPLE
SCALE: 20X

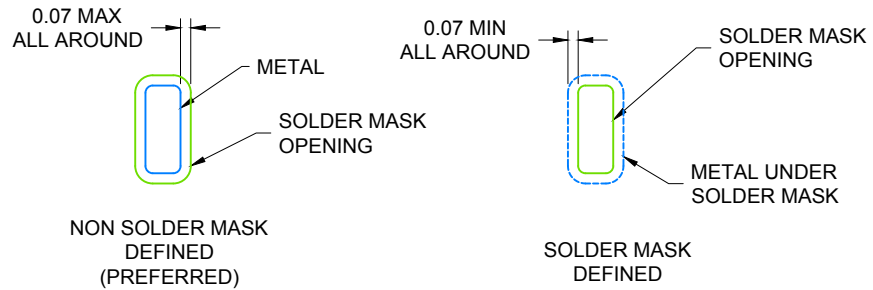

SOLDER MASK DETAILS

4219135/B 11/2016

NOTES: (continued)

- For more information, see Texas Instruments literature number SLUA271 (www.ti.com/lit/sl原因271).

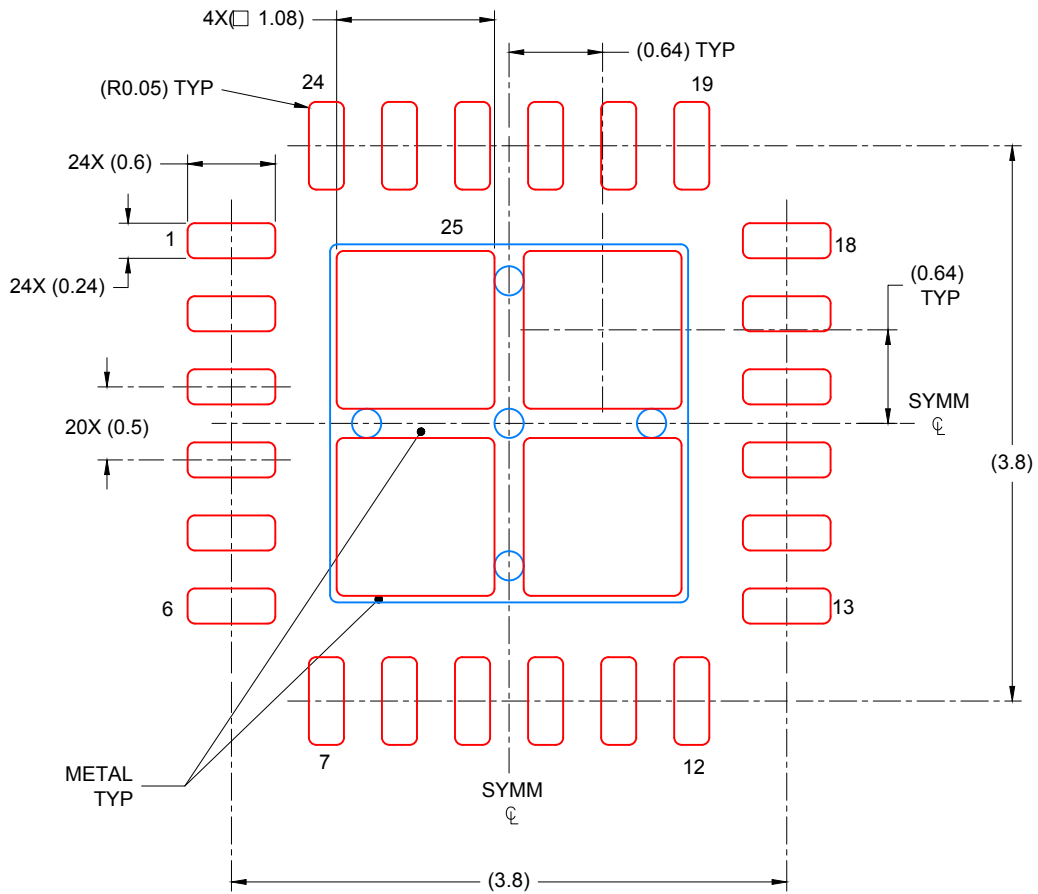

SOLDER PASTE EXAMPLE
 BASED ON 0.125 mm THICK STENCIL

EXPOSED PAD 25:
 78% PRINTED COVERAGE BY AREA UNDER PACKAGE
 SCALE: 20X

4219135/B 11/2016

NOTES: (continued)

4. Laser cutting apertures with trapezoidal walls and rounded corners may offer better paste release. IPC-7525 may have alternate design recommendations.

重要声明和免责声明

TI“按原样”提供技术和可靠性数据（包括数据表）、设计资源（包括参考设计）、应用或其他设计建议、网络工具、安全信息和其他资源，不保证没有瑕疵且不做任何明示或暗示的担保，包括但不限于对适销性、某特定用途方面的适用性或不侵犯任何第三方知识产权的暗示担保。

这些资源可供使用 TI 产品进行设计的熟练开发人员使用。您将自行承担以下全部责任：(1) 针对您的应用选择合适的 TI 产品，(2) 设计、验证并测试您的应用，(3) 确保您的应用满足相应标准以及任何其他功能安全、信息安全、监管或其他要求。

这些资源如有变更，恕不另行通知。TI 授权您仅可将这些资源用于研发本资源所述的 TI 产品的应用。严禁对这些资源进行其他复制或展示。您无权使用任何其他 TI 知识产权或任何第三方知识产权。您应全额赔偿因在这些资源的使用中对 TI 及其代表造成的任何索赔、损害、成本、损失和债务，TI 对此概不负责。

TI 提供的产品受 [TI 的销售条款](#) 或 [ti.com](#) 上其他适用条款/TI 产品随附的其他适用条款的约束。TI 提供这些资源并不会扩展或以其他方式更改 TI 针对 TI 产品发布的适用的担保或担保免责声明。

TI 反对并拒绝您可能提出的任何其他或不同的条款。

邮寄地址：Texas Instruments, Post Office Box 655303, Dallas, Texas 75265

Copyright © 2022，德州仪器 (TI) 公司