

# 具有 Eco-mode™ 的 4.5V 至 18V 输入，4A 同步降压转换器

查询样品: [TPS54428](#)

## 特性

- **D-CAP2™** 模式支持快速瞬态响应
- 低输出纹波，支持陶瓷输出电容器
- 宽泛的  $V_{IN}$  输入电压范围：**4.5V 至 18V**
- 输出电压范围：**0.76V 至 7.0V**
- 高效率集成型场效应晶体管 (FET) 针对较低占空比应用进行了优化  
-70mΩ (高侧) 与 53mΩ (低侧)
- 关断时的高效率，流耗不足 **10μA**
- 高初始带隙基准精度
- 可调软启动
- 预偏置软启动
- **650kHz** 开关频率 ( $f_{sw}$ )
- 逐周期过流限制
- 可在轻负载下实现高效率的自动跳跃 **Eco-mode™**

## 应用范围

- 低电压系统的广泛应用
  - 数字电视电源
  - 高清 **Blu-ray Disc™** 播放器
  - 网络家庭终端设备
  - 数字机顶盒 (**STB**)

## 说明

TPS54428 是一款自适应接通时间 D-CAP2™ 模式同步降压转换器。

TPS54428 可帮助系统设计人员通过一个成本有效、低组件数量、低待机电流解决方案来完成多种终端设备的电源总线调节器集。

TPS54428 的主控制环路采用 D-CAP2™ 模式控制，在无需外部补偿组件的情况下即可实现快速瞬态响应。

自适应接通时间控制支持较高负载状态下的脉宽调制 (PWM) 模式与轻负载下的 Eco-mode™ 运行之间的无缝转换。

Eco-mode™ 使 TPS54428 能够在较轻负载条件下保持高效率。

TPS54428 一个专有电路，使得器件能够采用诸如高分子有机半导体固体电容器 (POSCAP) 或高分子聚合物电容器 (SP-CAP) 等低等效串联电阻 (ESR) 输出电容器，以及超低 ESR 陶瓷电容器。该器件的工作输入电压介于 4.5V 至 18V  $V_{IN}$  输入之间。

可在

0.76V 至 7.0V 的范围内设定输出电压。

此器件还特有一个可调软启动时间。

TPS54428 采用 8 引脚 DDA 封装和 10 引脚 DRC 封装，并设计成在 -40°C 到 85°C 的环境温度范围内运行。

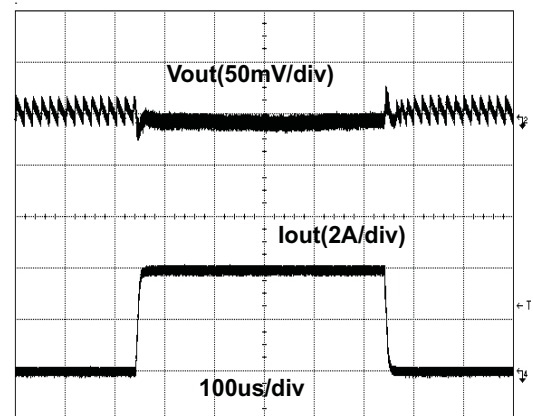
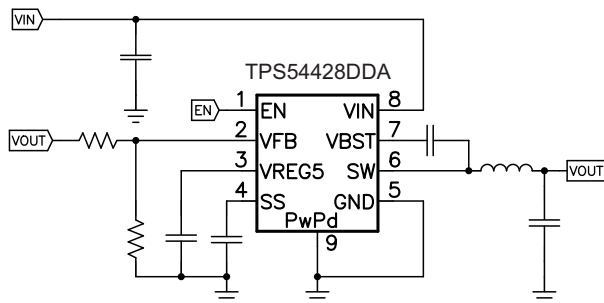

Please be aware that an important notice concerning availability, standard warranty, and use in critical applications of Texas Instruments semiconductor products and disclaimers thereto appears at the end of this data sheet.

D-CAP2 is a trademark of Texas Instruments.

Blu-ray Disc is a trademark of Blu-ray Disc Association.

# TPS54428

ZHCS511B – NOVEMBER 2011 – REVISED MARCH 2013

[www.ti.com.cn](http://www.ti.com.cn)

---



This integrated circuit can be damaged by ESD. Texas Instruments recommends that all integrated circuits be handled with appropriate precautions. Failure to observe proper handling and installation procedures can cause damage.

ESD damage can range from subtle performance degradation to complete device failure. Precision integrated circuits may be more susceptible to damage because very small parametric changes could cause the device not to meet its published specifications.

### ORDERING INFORMATION<sup>(1)</sup>

T <sub>A</sub>	PACKAGE <sup>(2)(3)</sup>	ORDERABLE PART NUMBER	PIN	TRANSPORT MEDIA
-40°C to 85°C	DDA	TPS54428DDA	8	Tube
		TPS54428DDAR		Tape and Reel
-40°C to 85°C	DRC	TPS54428DRCT	10	Tape and Reel
		TPS54428DRCR		Tape and Reel

- (1) For the most current package and ordering information, see the Package Option Addendum at the end of this document, or see the TI web site at [www.ti.com](http://www.ti.com).
- (2) Package drawings, thermal data, and symbolization are available at [www.ti.com/packaging](http://www.ti.com/packaging).
- (3) All package options have Cu NIPDAU lead/ball finish.

### ABSOLUTE MAXIMUM RATINGS

over operating free-air temperature range (unless otherwise noted)<sup>(1)</sup>

		VALUE		UNIT
		MIN	MAX	
Input voltage range	VIN, EN	-0.3	20	V
	VBST	-0.3	26	V
	VBST (10 ns transient)	-0.3	28	V
	VBST (vs SW)	-0.3	6.5	V
	VFB, SS	-0.3	6.5	V
	SW	-2	20	V
	SW (10 ns transient)	-3	22	V
Output voltage range	VREG5	-0.3	6.5	V
	GND	-0.3	0.3	V
Voltage from GND to thermal pad, V <sub>diff</sub>		-0.2	0.2	V
Electrostatic discharge	Human Body Model (HBM)		2	kV
	Charged Device Model (CDM)		500	V
Operating junction temperature, T <sub>J</sub>		-40	150	°C
Storage temperature, T <sub>stg</sub>		-55	150	°C

- (1) Stresses beyond those listed under *absolute maximum ratings* may cause permanent damage to the device. These are stress ratings only, and functional operation of the device at these or any other conditions beyond those indicated under *recommended operating conditions* is not implied. Exposure to absolute-maximum-rated conditions for extended periods may affect device reliability.

### THERMAL INFORMATION

THERMAL METRIC <sup>(1)</sup>		TPS54428		UNITS
		DDA (8 PINS)	DRC (10 PINS)	
θ <sub>JA</sub>	Junction-to-ambient thermal resistance	42.1	43.2	°C/W
θ <sub>JCtop</sub>	Junction-to-case (top) thermal resistance	50.9	53.8	
θ <sub>JB</sub>	Junction-to-board thermal resistance	31.8	18.2	
ψ <sub>JT</sub>	Junction-to-top characterization parameter	5	0.6	
ψ <sub>JB</sub>	Junction-to-board characterization parameter	13.5	18.3	
θ <sub>JCbot</sub>	Junction-to-case (bottom) thermal resistance	7.1	4.7	

- (1) 有关传统和新的热 度量的更多信息，请参阅 IC 封装热度量应用报告，SPRA953。

## RECOMMENDED OPERATING CONDITIONS

over operating free-air temperature range (unless otherwise noted)

			MIN	MAX	UNIT
V <sub>IN</sub>	Supply input voltage range		4.5	18	V
V <sub>I</sub>	Input voltage range	VBST	-0.1	24	V
		VBST (10 ns transient)	-0.1	27	
		VBST(vs SW)	-0.1	5.7	
		SS	-0.1	5.7	
		EN	-0.1	18	
		VFB	-0.1	5.5	
		SW	-1.8	18	
		SW (10 ns transient)	-3	21	
		GND	-0.1	0.1	
V <sub>O</sub>	Output voltage range	VREG5	-0.1	5.7	V
I <sub>O</sub>	Output Current range	I <sub>VREG5</sub>	0	10	mA
T <sub>A</sub>	Operating free-air temperature		-40	85	°C
T <sub>J</sub>	Operating junction temperature		-40	150	°C

## ELECTRICAL CHARACTERISTICS

 over operating free-air temperature range, V<sub>IN</sub> = 12 V (unless otherwise noted)

PARAMETER		TEST CONDITIONS	MIN	TYP	MAX	UNIT
<b>SUPPLY CURRENT</b>						
I <sub>VIN</sub>	Operating - non-switching supply current	V <sub>IN</sub> current, T <sub>A</sub> = 25°C, EN = 5 V, V <sub>F<sub>B</sub></sub> = 0.8 V		950	1400	μA
I <sub>VINSDN</sub>	Shutdown supply current	V <sub>IN</sub> current, T <sub>A</sub> = 25°C, EN = 0 V		3.0	10	μA
<b>LOGIC THRESHOLD</b>						
V <sub>ENH</sub>	EN high-level input voltage	EN	1.6			V
V <sub>ENL</sub>	EN low-level input voltage	EN			0.6	V
R <sub>EN</sub>	EN pin resistance to GND	V <sub>EN</sub> = 12 V	225	450	900	kΩ
<b>V<sub>F<sub>B</sub></sub> VOLTAGE AND DISCHARGE RESISTANCE</b>						
V <sub>F<sub>B</sub></sub> TH	V <sub>F<sub>B</sub></sub> threshold voltage	T <sub>A</sub> = 25°C, V <sub>O</sub> = 1.05 V, I <sub>O</sub> = 10 mA, Eco-mode™ operation		771		mV
		T <sub>A</sub> = 25°C, V <sub>O</sub> = 1.05 V, continuous mode operation	757	765	773	
		T <sub>A</sub> = -40°C to 85°C, V <sub>O</sub> = 1.05V, continuous mode operation <sup>(1)</sup>	751	765	779	
I <sub>V<sub>F<sub>B</sub></sub></sub>	V <sub>F<sub>B</sub></sub> input current	V <sub>F<sub>B</sub></sub> = 0.8 V, T <sub>A</sub> = 25°C		0	±0.1	μA
<b>V<sub>REG5</sub> OUTPUT</b>						
V <sub>V<sub>REG5</sub></sub>	V <sub>REG5</sub> output voltage	T <sub>A</sub> = 25°C, 6.0 V < V <sub>IN</sub> < 18 V, 0 < I <sub>V<sub>REG5</sub></sub> < 5 mA	5.2	5.5	5.7	V
V <sub>LN5</sub>	Line regulation	6 V < V <sub>IN</sub> < 18 V, I <sub>V<sub>REG5</sub></sub> = 5 mA			25	mV
V <sub>LD5</sub>	Load regulation	0 mA < I <sub>V<sub>REG5</sub></sub> < 5 mA			100	mV
I <sub>V<sub>REG5</sub></sub>	Output current	V <sub>IN</sub> = 6 V, V <sub>REG5</sub> = 4.0 V, T <sub>A</sub> = 25°C		60		mA
<b>MOSFET</b>						
R <sub>DS(on)h</sub>	High side switch resistance, DDA	25°C, V <sub>BST</sub> - SW = 5.5 V		70		mΩ
R <sub>DS(on)h</sub>	High side switch resistance, DRC	25°C, V <sub>BST</sub> - SW = 5.5 V		74		mΩ
R <sub>DS(on)l</sub>	Low side switch resistance	25°C		53		mΩ
<b>CURRENT LIMIT</b>						
I <sub>ocl</sub>	Current limit	L out = 1.5 μH <sup>(1)</sup>	4.6	5.3	6.8	A

(1) Not production tested.

**ELECTRICAL CHARACTERISTICS (continued)**

over operating free-air temperature range,  $V_{IN} = 12\text{ V}$  (unless otherwise noted)

PARAMETER		TEST CONDITIONS	MIN	TYP	MAX	UNIT
<b>THERMAL SHUTDOWN</b>						
$T_{SDN}$	Thermal shutdown threshold	Shutdown temperature <sup>(2)</sup>		170		°C
		Hysteresis <sup>(2)</sup>		35		
<b>ON-TIME TIMER CONTROL</b>						
$t_{ON}$	On time	$V_{IN} = 12\text{ V}, V_O = 1.05\text{ V}$		150		ns
$t_{OFF(MIN)}$	Minimum off time	$T_A = 25^\circ\text{C}, V_{FB} = 0.7\text{ V}$		260	310	ns
<b>SOFT START</b>						
$I_{SSC}$	SS charge current	$V_{SS} = 0\text{ V}$	4.2	6.0	7.8	μA
$I_{SSD}$	SS discharge current	$V_{SS} = 1\text{ V}$	0.1	0.2		mA
<b>UVLO</b>						
UVLO	UVLO threshold	Wake up $V_{REG5}$ voltage	3.45	3.75	4.05	V
		Hysteresis $V_{REG5}$ voltage	0.19	0.32	0.45	

(2) Not production tested.

**DEVICE INFORMATION**

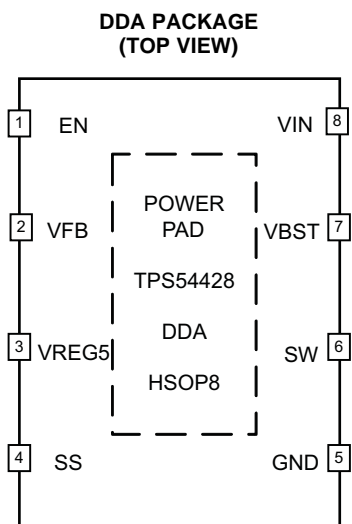

**DRC PACKAGE (TOP VIEW)**

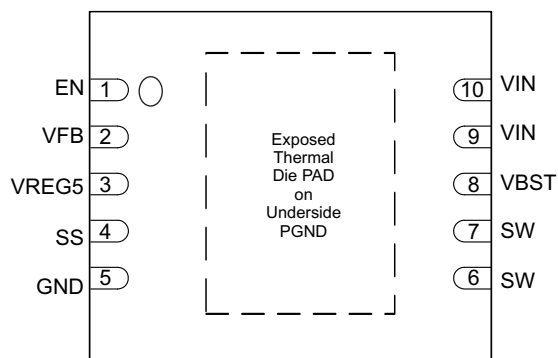

**PIN FUNCTIONS**

PIN			DESCRIPTION
NAME	DDA	DRC	
EN	1	1	Enable input control. Active high.
VFB	2	2	Converter feedback input. Connect to output voltage with feedback resistor divider.
VREG5	3	3	5.5 V power supply output. A capacitor (typical 1 $\mu$ F) should be connected to GND. VREG5 is not active when EN is low.
SS	4	4	Soft-start control. An external capacitor should be connected to GND.
GND	5		Ground pin. Power ground return for switching circuit. Connect sensitive SS and VFB returns to GND at a single point.
GND		5	Ground pin. Connect sensitive SS and VFB returns to GND at a single point.
SW	6	6, 7	Switch node connection between high-side NFET and low-side NFET.
VBST	7	8	Supply input for the high-side FET gate drive circuit. Connect 0.1 $\mu$ F capacitor between VBST and SW pins. An internal diode is connected between VREG5 and VBST.
VIN	8	9, 10	Input voltage supply pin.
Exposed Thermal Pad	Back side		Thermal pad of the package. Must be soldered to achieve appropriate dissipation. Must be connected to GND.
Exposed Thermal Pad		Back side	Thermal pad of the package. PGND power ground return of internal low-side FET. Must be soldered to achieve appropriate dissipation.

**FUNCTIONAL BLOCK DIAGRAM**

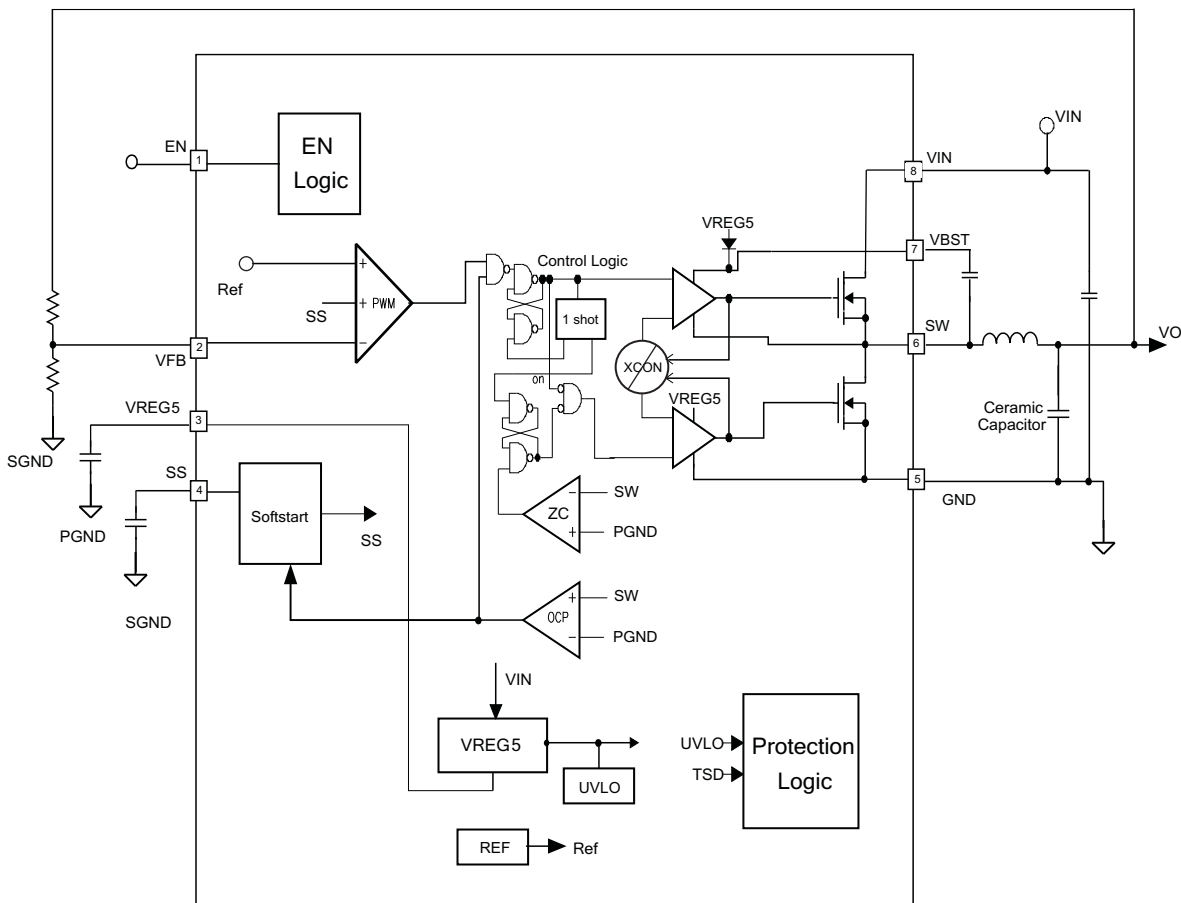

## OVERVIEW

The TPS54428 is a 4-A synchronous step-down (buck) converter with two integrated N-channel MOSFETs. It operates using D-CAP2™ mode control. The fast transient response of D-CAP2™ control reduces the output capacitance required to meet a specific level of performance. Proprietary internal circuitry allows the use of low ESR output capacitors including ceramic and special polymer types.

## DETAILED DESCRIPTION

### PWM Operation

The main control loop of the TPS54428 is an adaptive on-time pulse width modulation (PWM) controller that supports a proprietary D-CAP2™ mode control. D-CAP2™ mode control combines constant on-time control with an internal compensation circuit for pseudo-fixed frequency and low external component count configuration with both low ESR and ceramic output capacitors. It is stable even with virtually no ripple at the output.

At the beginning of each cycle, the high-side MOSFET is turned on. This MOSFET is turned off after internal one shot timer expires. This one shot is set by the converter input voltage, VIN, and the output voltage, VO, to maintain a pseudo-fixed frequency over the input voltage range, hence it is called adaptive on-time control. The one-shot timer is reset and the high-side MOSFET is turned on again when the feedback voltage falls below the reference voltage. An internal ramp is added to reference voltage to simulate output ripple, eliminating the need for ESR induced output ripple from D-CAP2™ mode control.

### PWM Frequency and Adaptive On-Time Control

TPS54428 uses an adaptive on-time control scheme and does not have a dedicated on board oscillator. The TPS54428 runs with a pseudo-constant frequency of 650 kHz by using the input voltage and output voltage to set the on-time one-shot timer. The on-time is inversely proportional to the input voltage and proportional to the output voltage, therefore, when the duty ratio is VOUT/VIN, the frequency is constant.

### Auto-Skip Eco-Mode™ Control

The TPS54428 is designed with Auto-Skip Eco-mode™ to increase light load efficiency. As the output current decreases from heavy load condition, the inductor current is also reduced and eventually comes to point that its rippled valley touches zero level, which is the boundary between continuous conduction and discontinuous conduction modes. The rectifying MOSFET is turned off when its zero inductor current is detected. As the load current further decreases the converter run into discontinuous conduction mode. The on-time is kept almost the same as is was in the continuous conduction mode so that it takes longer time to discharge the output capacitor with smaller load current to the level of the reference voltage. The transition point to the light load operation IOUT(LL) current can be calculated in Equation 1.

$$I_{OUT(LL)} = \frac{1}{2 \times L \times f_{SW}} \times \frac{(V_{IN} - V_{OUT}) \times V_{OUT}}{V_{IN}} \quad (1)$$

### Soft Start and Pre-Biased Soft Start

The soft start function is adjustable. When the EN pin becomes high, 6-μA current begins charging the capacitor which is connected from the SS pin to GND. Smooth control of the output voltage is maintained during start up. The equation for the slow start time is shown in Equation 2. VFB voltage is 0.765 V and SS pin source current is 6-μA.

$$T_{SS}(ms) = \frac{C6(nF) \times V_{ref} \times 1.1}{I_{SS}(\mu A)} = \frac{C6(nF) \times 0.765 \times 1.1}{6} \quad (2)$$

The TPS54428 contains a unique circuit to prevent current from being pulled from the output during startup if the output is pre-biased. When the soft-start commands a voltage higher than the pre-bias level (internal soft start becomes greater than feedback voltage VFB), the controller slowly activates synchronous rectification by starting the first low side FET gate driver pulses with a narrow on-time. It then increments that on-time on a cycle-by-cycle basis until it coincides with the time dictated by (1-D), where D is the duty cycle of the converter. This scheme prevents the initial sinking of the pre-bias output, and ensure that the out voltage (VO) starts and ramps up smoothly into regulation and the control loop is given time to transition from pre-biased start-up to normal mode operation.

## Current Protection

The output over-current protection (OCP) is implemented using a cycle-by-cycle valley detect control circuit. The switch current is monitored by measuring the low-side FET switch voltage between the SW pin and GND. This voltage is proportional to the switch current. To improve accuracy, the voltage sensing is temperature compensated.

During the on time of the high-side FET switch, the switch current increases at a linear rate determined by  $V_{in}$ ,  $V_{out}$ , the on-time and the output inductor value. During the on time of the low-side FET switch, this current decreases linearly. The average value of the switch current is the load current  $I_{out}$ . The TPS54428 constantly monitors the low-side FET switch voltage, which is proportional to the switch current, during the low-side on-time. If the measured voltage is above the voltage proportional to the current limit, an internal counter is incremented per each SW cycle and the converter maintains the low-side switch on until the measured voltage is below the voltage corresponding to the current limit at which time the switching cycle is terminated and a new switching cycle begins. In subsequent switching cycles, the on-time is set to a fixed value and the current is monitored in the same manner. If the over current condition exists for 7 consecutive switching cycles, the internal OCL threshold is set to a lower level, reducing the available output current. When a switching cycle occurs where the switch current is not above the lower OCL threshold, the counter is reset and the OCL limit is returned to the higher value.

There are some important considerations for this type of over-current protection. The load current one half of the peak-to-peak inductor current is higher than the over-current threshold also when the current is being limited, the output voltage tends to fall as the demanded load current may be higher than the current available from the converter. This may cause the output voltage to fall. When the over current condition is removed, the output voltage returns to the regulated value. This protection is non-latching.

## UVLO Protection

Undervoltage lock out protection (UVLO) monitors the voltage of the VREG5 pin. When the VREG5 voltage is lower than UVLO threshold voltage, the TPS54428 is shut off. This protection is non-latching.

## Thermal Shutdown

TPS54428 monitors the temperature of itself. If the temperature exceeds the threshold value (typically 170°C), the device is shut off. This is non-latch protection.

## TYPICAL CHARACTERISTICS

$V_{IN} = 12\text{ V}$ ,  $T_A = 25^\circ\text{C}$  (unless otherwise noted)

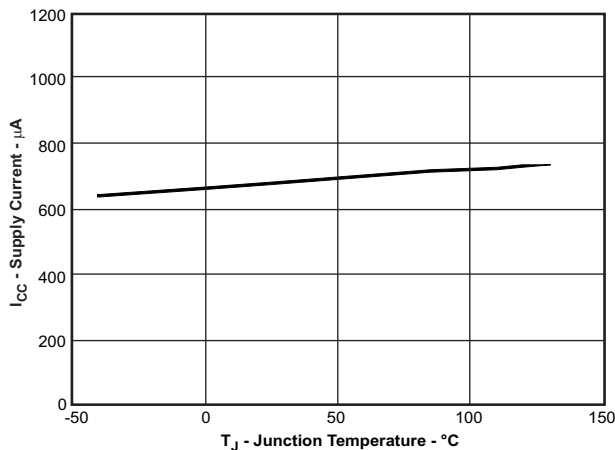

Figure 1. VIN CURRENT vs JUNCTION TEMPERATURE

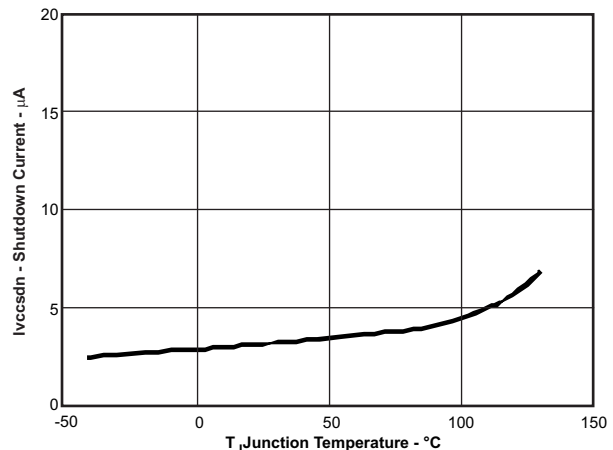

Figure 2. VIN SHUTDOWN CURRENT vs JUNCTION TEMPERATURE

TYPICAL CHARACTERISTICS (continued)

VIN = 12 V, TA = 25°C (unless otherwise noted)

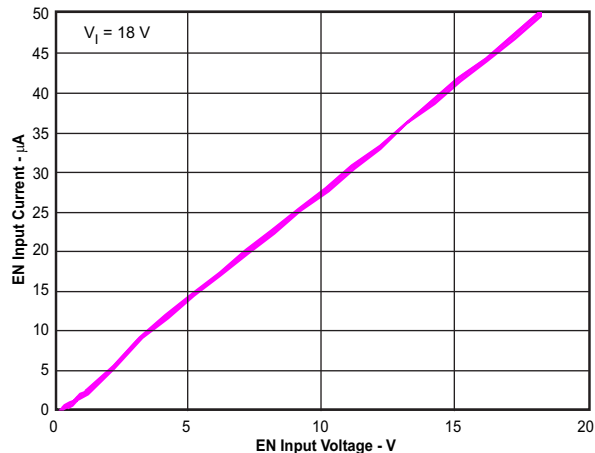

Figure 3. EN CURRENT vs EN VOLTAGE

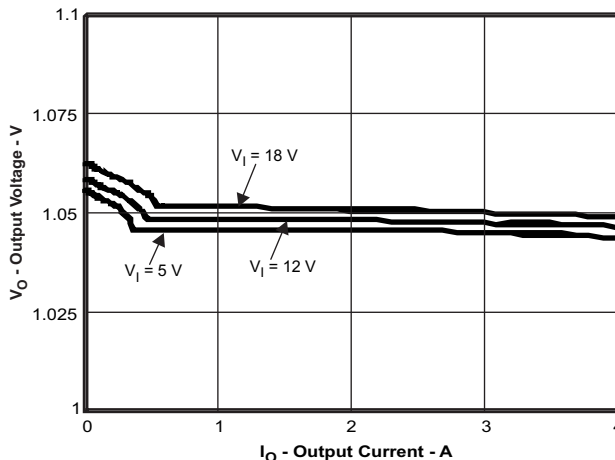

Figure 4. 1.05V OUTPUT VOLTAGE vs OUTPUT CURRENT

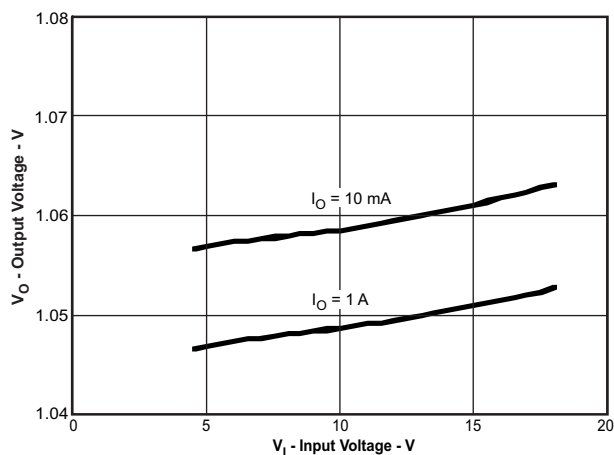

Figure 5. 1.05V OUTPUT VOLTAGE vs VIN VOLTAGE

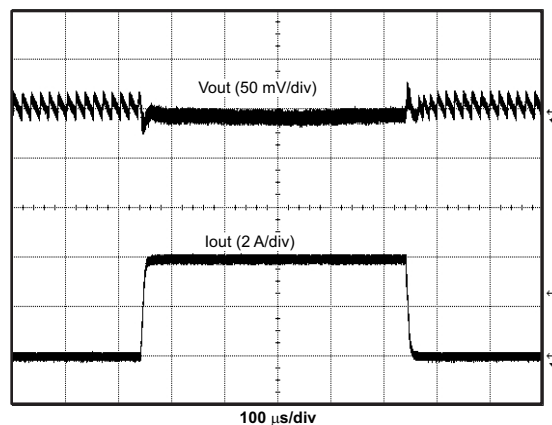

Figure 6. 1.05V LOAD TRANSIENT RESPONSE

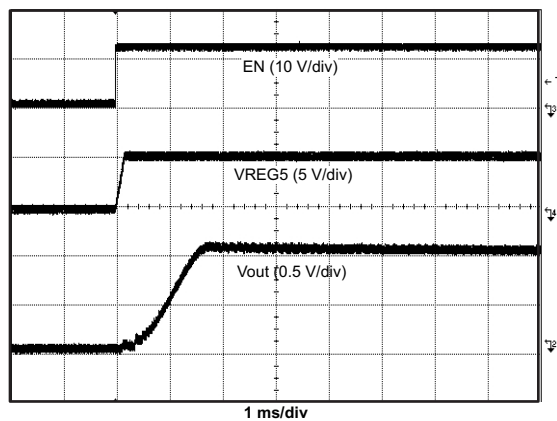

Figure 7. START UP WAVEFORM

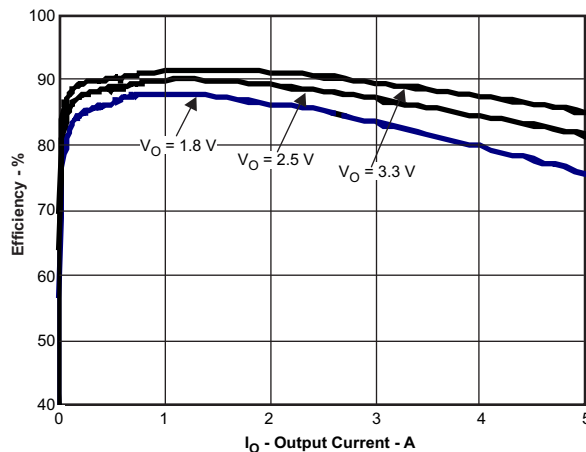

Figure 8. EFFICIENCY vs OUTPUT CURRENT

TYPICAL CHARACTERISTICS (continued)

VIN = 12 V, TA = 25°C (unless otherwise noted)

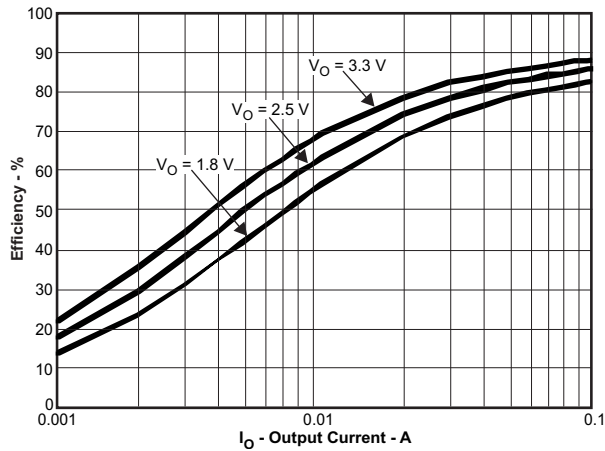

Figure 9. LIGHT LOAD EFFICIENCY vs OUTPUT CURRENT

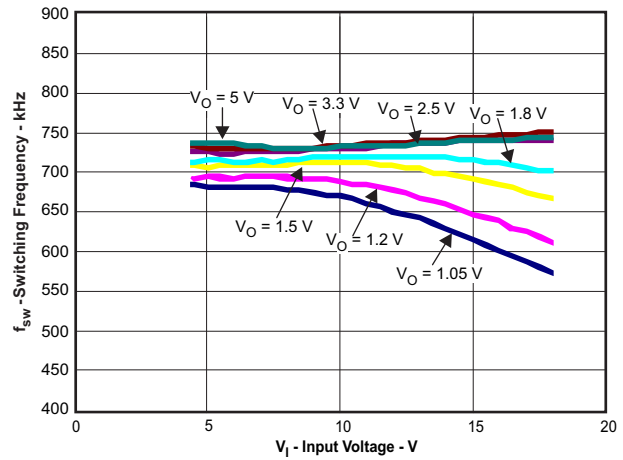

Figure 10. SWITCHING FREQUENCY vs INPUT VOLTAGE

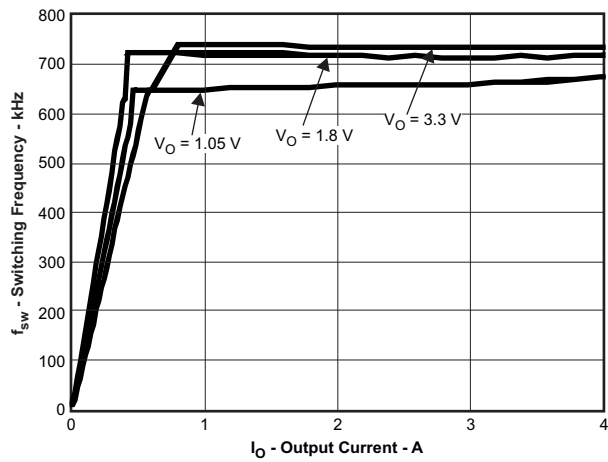

Figure 11. SWITCHING FREQUENCY vs OUTPUT CURRENT

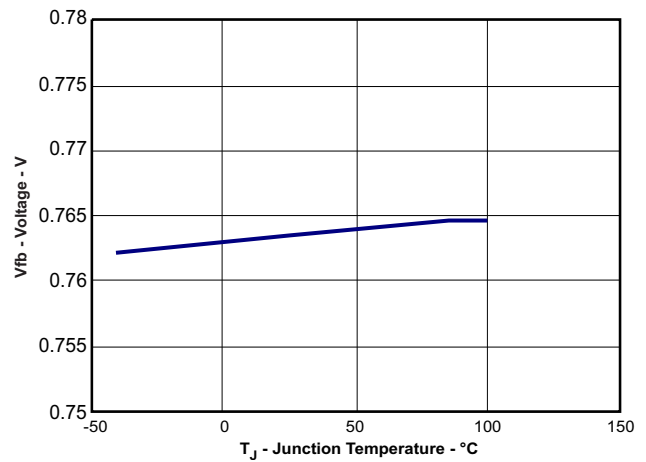

Figure 12. VFB VOLTAGE vs JUNCTION TEMPERATURE

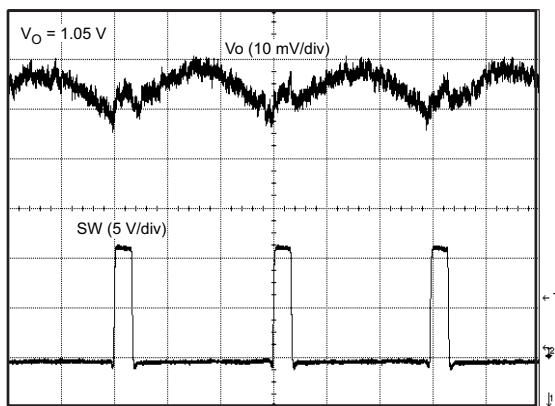

Figure 13. VOLTAGE RIPPLE vs RIPPLE AT OUTPUT (Io = 4A)

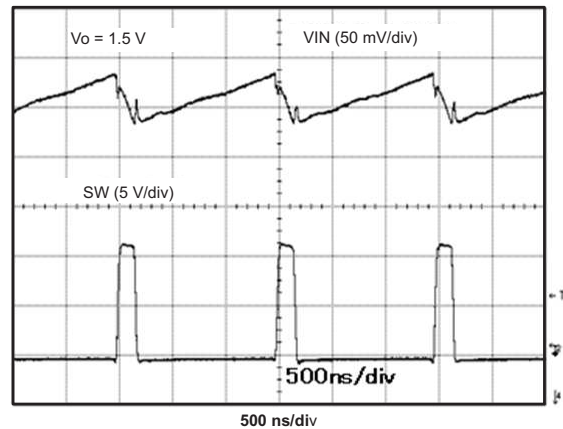

Figure 14. VOLTAGE RIPPLE vs RIPPLE AT INPUT (Io = 4A)

## DESIGN GUIDE

### Step By Step Design Procedure

To begin the design process, you must know a few application parameters:

- Input voltage range
- Output voltage
- Output current
- Output voltage ripple
- Input voltage ripple

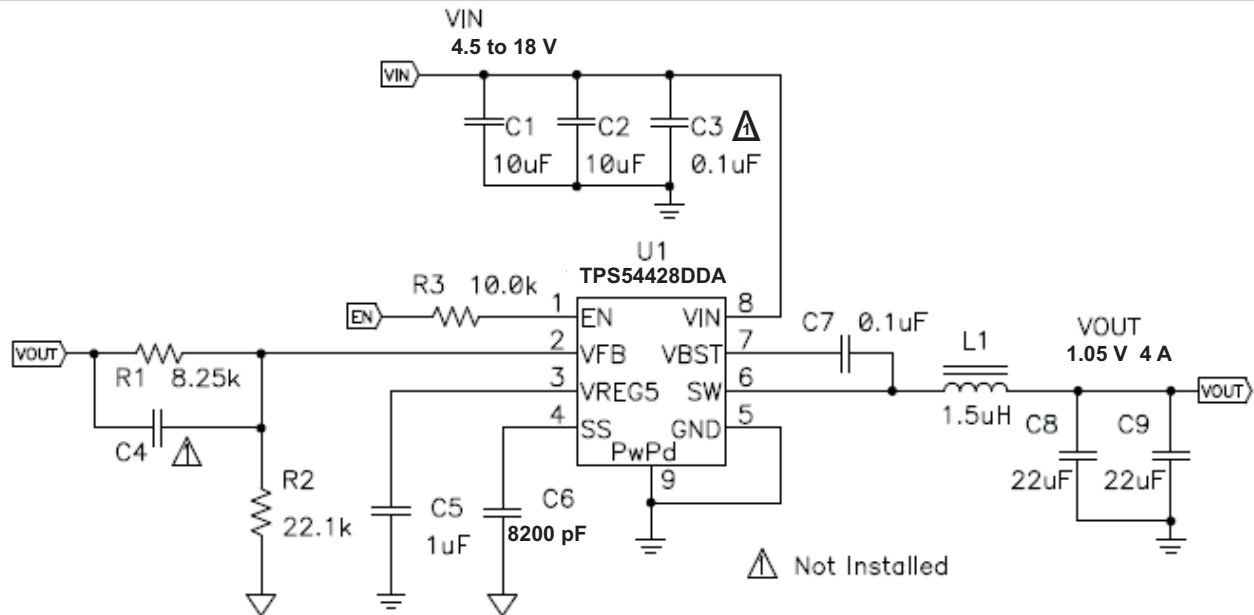

Figure 15. Schematic Diagram for This Design Example.

### Output Voltage Resistors Selection

The output voltage is set with a resistor divider from the output node to the VFB pin. It is recommended to use 1% tolerance or better divider resistors. Start by using Equation 3 to calculate  $V_{OUT}$ .

To improve efficiency at very light loads consider using larger value resistors, too high of resistance will be more susceptible to noise and voltage errors from the VFB input current will be more noticeable.

$$V_{OUT} = 0.765 \times \left( 1 + \frac{R1}{R2} \right) \quad (3)$$

### Output Filter Selection

The output filter used with the TPS54428 is an LC circuit. This LC filter has double pole at:

$$F_p = \frac{1}{2\pi \sqrt{L_{OUT} \times C_{OUT}}} \quad (4)$$

At low frequencies, the overall loop gain is set by the output set-point resistor divider network and the internal gain of the TPS54428. The low frequency phase is 180 degrees. At the output filter pole frequency, the gain rolls off at a  $-40$  dB per decade rate and the phase drops rapidly. D-CAP2™ introduces a high frequency zero that reduces the gain roll off to  $-20$  dB per decade and increases the phase to 90 degrees one decade above the zero frequency. The inductor and capacitor selected for the output filter must be selected so that the double pole of is located below the high frequency zero but close enough that the phase boost provided by the high frequency zero provides adequate phase margin for a stable circuit. To meet this requirement use the values recommended in Table 1.

**Table 1. Recommended Component Values**

Output Voltage (V)	R1 (kΩ)	R2 (kΩ)	C4 (pF) <sup>(1)</sup>	L1 (μH)	C8 + C9 (μF)
1	6.81	22.1		1.5	22 - 68
1.05	8.25	22.1		1.5	22 - 68
1.2	12.7	22.1		1.5	22 - 68
1.5	21.5	22.1		1.5	22 - 68
1.8	30.1	22.1	5 - 22	2.2	22 - 68
2.5	49.9	22.1	5 - 22	2.2	22 - 68
3.3	73.2	22.1	5 - 22	2.2	22 - 68
5	124	22.1	5 - 22	3.3	22 - 68
6.5	165	22.1	5 - 22	3.3	22 - 68

(1) Optional

For higher output voltages at or above 1.8 V, additional phase boost can be achieved by adding a feed forward capacitor (C4) in parallel with R1

The inductor peak-to-peak ripple current, peak current and RMS current are calculated using [Equation 5](#), [Equation 6](#) and [Equation 7](#). The inductor saturation current rating must be greater than the calculated peak current and the RMS or heating current rating must be greater than the calculated RMS current. Use 650 kHz for  $f_{SW}$ .

Use 650 kHz for  $f_{SW}$ . Make sure the chosen inductor is rated for the peak current of [Equation 6](#) and the RMS current of [Equation 7](#).

$$I_{P-P} = \frac{V_{OUT}}{V_{IN(MAX)}} \times \frac{V_{IN(MAX)} - V_{OUT}}{L_O \times f_{SW}} \quad (5)$$

$$I_{PEAK} = I_O + \frac{I_{P-P}}{2} \quad (6)$$

$$I_{L(O,RMS)} = \sqrt{I_O^2 + \frac{1}{12} I_{P-P}^2} \quad (7)$$

For this design example, the calculated peak current is 4.51 A and the calculated RMS current is 4.01 A. The inductor used is a TDK SPM6530-1R5M100 with a peak current rating of 11.5 A and an RMS current rating of 11 A.

The capacitor value and ESR determines the amount of output voltage ripple. The TPS54428 is intended for use with ceramic or other low ESR capacitors. Recommended values range from 22μF to 68μF. Use [Equation 8](#) to determine the required RMS current rating for the output capacitor.

$$I_{CO(RMS)} = \frac{V_{OX} \times (V_{IN} - V_{OUT})}{\sqrt{12} \times V_{IN} \times L_O \times f_{SW}} \quad (8)$$

For this design two TDK C3216X5R0J226M 22μF output capacitors are used. The typical ESR is 2 mΩ each. The calculated RMS current is 0.286A and each output capacitor is rated for 4A.

### Input Capacitor Selection

The TPS54428 requires an input decoupling capacitor and a bulk capacitor is needed depending on the application. A ceramic capacitor over 10μF is recommended for the decoupling capacitor. An additional 0.1 μF capacitor from pin 8 to ground is optional to provide additional frequency filtering. The capacitor voltage rating needs to be greater than the maximum input voltage.

### Bootstrap Capacitor Selection

A 0.1μF ceramic capacitor must be connected between the VBST to SW pin for proper operation. It is recommended to use a ceramic capacitor.

### VREG5 Capacitor Selection

A 1- $\mu$ F ceramic capacitor must be connected between the VREG5 to GND pin for proper operation. It is recommended to use a ceramic capacitor

### THERMAL INFORMATION

This 8-pin DDA package incorporates an exposed thermal pad that is designed to be directly to an external heatsink. The thermal pad must be soldered directly to the printed board (PCB). After soldering, the PCB can be used as a heatsink. In addition, through the use of thermal vias, the thermal pad can be attached directly to the appropriate copper plane shown in the electrical schematic for the device, or alternatively, can be attached to a special heatsink structure designed into the PCB. This design optimizes the heat transfer from the integrated circuit (IC).

For additional information on the exposed thermal pad and how to use the advantage of its heat dissipating abilities, refer to Technical Brief, PowerPAD™ Thermally Enhanced Package, Texas Instruments Literature No. [SLMA002](#) and Application Brief, PowerPAD™ Made Easy, Texas Instruments Literature No. [SLMA004](#).

The exposed thermal pad dimensions for this package are shown in [Figure 16](#).

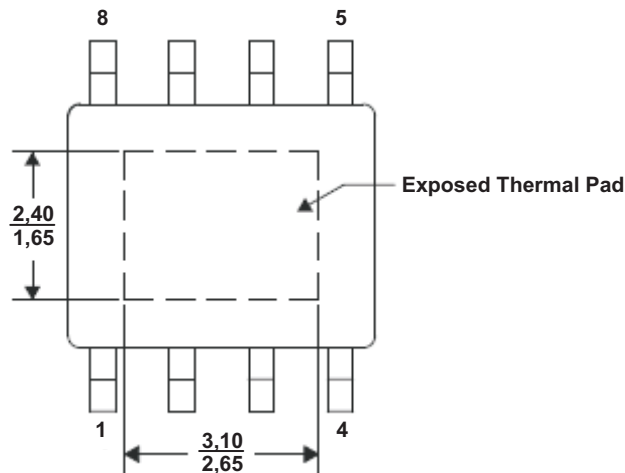
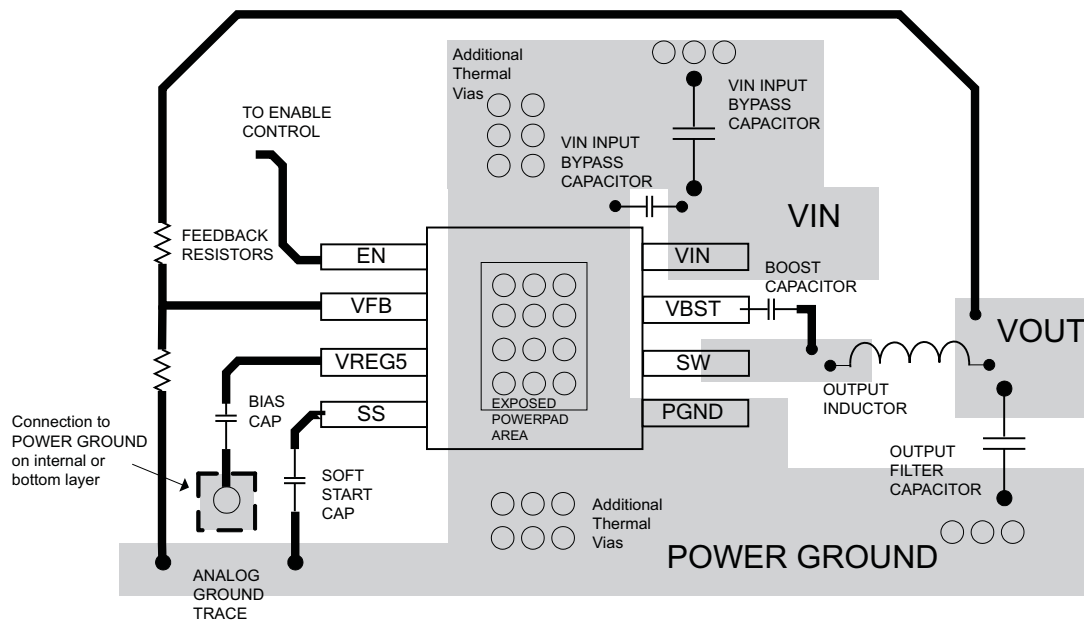

Figure 16. Thermal Pad Dimensions

## LAYOUT CONSIDERATIONS

1. Keep the input switching current loop as small as possible.
2. Keep the SW node as physically small and short as possible to minimize parasitic capacitance and inductance and to minimize radiated emissions. Kelvin connections should be brought from the output to the feedback pin of the device.
3. Keep analog and non-switching components away from switching components.
4. Make a single point connection from the signal ground to power ground.
5. Do not allow switching current to flow under the device.
6. Keep the pattern lines for VIN and PGND broad.
7. Exposed pad of device must be connected to PGND with solder.
8. VREG5 capacitor should be placed near the device, and connected PGND.
9. Output capacitor should be connected to a broad pattern of the PGND.
10. Voltage feedback loop should be as short as possible, and preferably with ground shield.
11. Lower resistor of the voltage divider which is connected to the VFB pin should be tied to SGND.
12. Providing sufficient vias for VIN, SW and PGND connection.
13. PCB pattern for VIN, SW, and PGND should be as broad as possible.
14. VIN Capacitor should be placed as near as possible to the device.
15. The TPS54428 can supply relatively large current up to 4A. So heat dissipation may be a concern. The top-side area adjacent to the TPS54428 should be filled with ground as much as possible to dissipate heat.
16. The bottom-side area directly below the IC should a dedicated ground area. It should be directly connected to the thermal pad using vias as shown. The ground area should be as large as practical. Additional internal layers can be dedicated as ground planes and connected to vias as well.



**Figure 17. TPS54428 Layout**

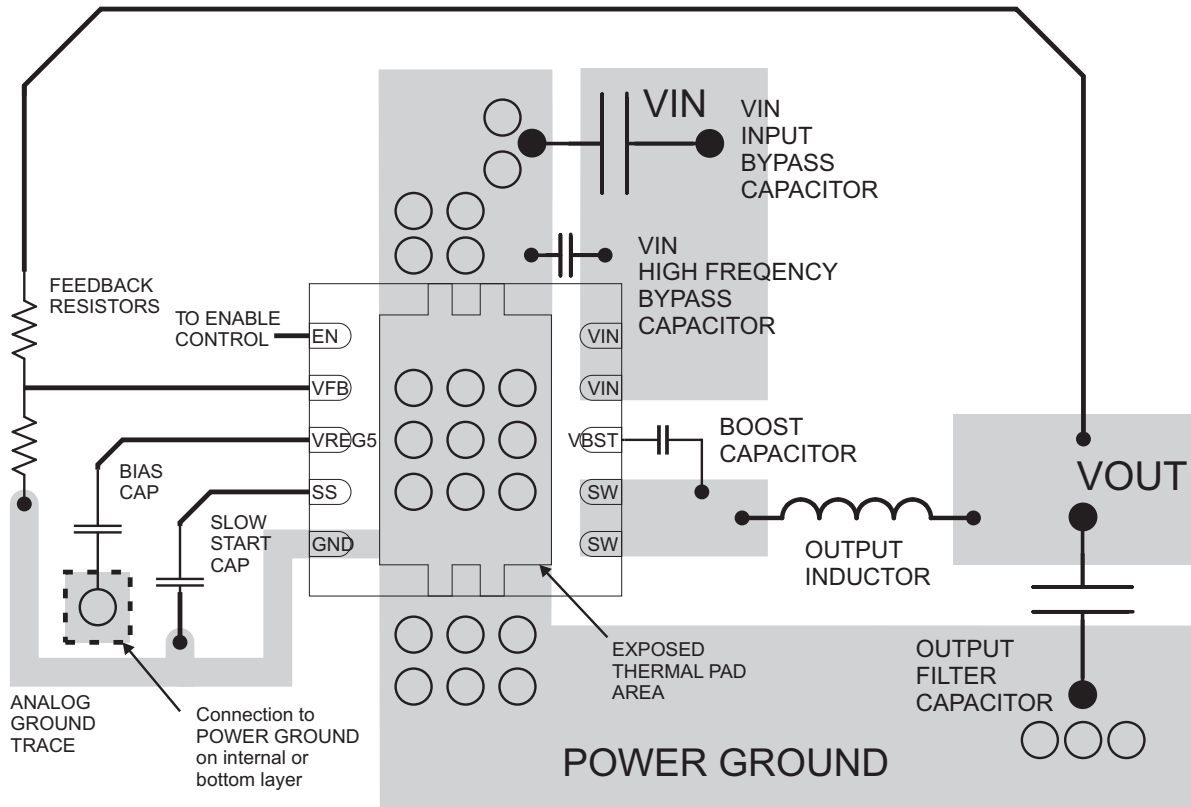

○ VIA to Ground Plane

Figure 18. PCB Layout for the DRC Package

## REVISION HISTORY

---

<b>Changes from Original (November 2011) to Revision A</b>	<b>Page</b>
--	-------------

---

- |   |   |
|---|---|
| • Deleted $T_A = -20^{\circ}\text{C}$ to $85^{\circ}\text{C}$ from ELEC CHARA table, CURRENT LIMIT section, Test Conditions statement ..... | 4 |
|---|---|
- 

<b>Changes from Revision A (January 2012) to Revision B</b>	<b>Page</b>
---	-------------

---

- |  |    |
|--|----|
| • 将说明文本更改为包括 DRC 封装 .....  | 1  |
| • Added the DRC-10 pin Package to the ORDERING INFORMATION table ..... | 3  |
| • Added the DRC-10 pin Package to the Thermal Inforamtion table .....  | 3  |
| • Added the DRC-10 Pin package pin out .....                           | 5  |
| • Added <a href="#">Figure 18</a> .....                                | 15 |
-

**PACKAGING INFORMATION**

Orderable Device	Status (1)	Package Type	Package Drawing	Pins	Package Qty	Eco Plan (2)	Lead finish/ Ball material (6)	MSL Peak Temp (3)	Op Temp (°C)	Device Marking (4/5)	Samples
TPS54428DDA	ACTIVE	SO PowerPAD	DDA	8	75	RoHS & Green	NIPDAU   SN	Level-2-260C-1 YEAR	-40 to 85	54428	<a href="#">Samples</a>
TPS54428DDAR	ACTIVE	SO PowerPAD	DDA	8	2500	RoHS & Green	NIPDAU   SN	Level-2-260C-1 YEAR	-40 to 85	54428	<a href="#">Samples</a>
TPS54428DRCR	ACTIVE	VSON	DRC	10	3000	RoHS & Green	NIPDAU	Level-2-260C-1 YEAR	-40 to 85	54428	<a href="#">Samples</a>
TPS54428DRCT	ACTIVE	VSON	DRC	10	250	RoHS & Green	NIPDAU	Level-2-260C-1 YEAR	-40 to 85	54428	<a href="#">Samples</a>

(1) The marketing status values are defined as follows:

**ACTIVE:** Product device recommended for new designs.

**LIFEBUY:** TI has announced that the device will be discontinued, and a lifetime-buy period is in effect.

**NRND:** Not recommended for new designs. Device is in production to support existing customers, but TI does not recommend using this part in a new design.

**PREVIEW:** Device has been announced but is not in production. Samples may or may not be available.

**OBSOLETE:** TI has discontinued the production of the device.

(2) **RoHS:** TI defines "RoHS" to mean semiconductor products that are compliant with the current EU RoHS requirements for all 10 RoHS substances, including the requirement that RoHS substance do not exceed 0.1% by weight in homogeneous materials. Where designed to be soldered at high temperatures, "RoHS" products are suitable for use in specified lead-free processes. TI may reference these types of products as "Pb-Free".

**RoHS Exempt:** TI defines "RoHS Exempt" to mean products that contain lead but are compliant with EU RoHS pursuant to a specific EU RoHS exemption.

**Green:** TI defines "Green" to mean the content of Chlorine (Cl) and Bromine (Br) based flame retardants meet JS709B low halogen requirements of <=1000ppm threshold. Antimony trioxide based flame retardants must also meet the <=1000ppm threshold requirement.

(3) MSL, Peak Temp. - The Moisture Sensitivity Level rating according to the JEDEC industry standard classifications, and peak solder temperature.

(4) There may be additional marking, which relates to the logo, the lot trace code information, or the environmental category on the device.

(5) Multiple Device Markings will be inside parentheses. Only one Device Marking contained in parentheses and separated by a "-" will appear on a device. If a line is indented then it is a continuation of the previous line and the two combined represent the entire Device Marking for that device.

(6) Lead finish/Ball material - Orderable Devices may have multiple material finish options. Finish options are separated by a vertical ruled line. Lead finish/Ball material values may wrap to two lines if the finish value exceeds the maximum column width.

**Important Information and Disclaimer:**The information provided on this page represents TI's knowledge and belief as of the date that it is provided. TI bases its knowledge and belief on information provided by third parties, and makes no representation or warranty as to the accuracy of such information. Efforts are underway to better integrate information from third parties. TI has taken and

continues to take reasonable steps to provide representative and accurate information but may not have conducted destructive testing or chemical analysis on incoming materials and chemicals. TI and TI suppliers consider certain information to be proprietary, and thus CAS numbers and other limited information may not be available for release.

In no event shall TI's liability arising out of such information exceed the total purchase price of the TI part(s) at issue in this document sold by TI to Customer on an annual basis.

**TAPE AND REEL INFORMATION**

**QUADRANT ASSIGNMENTS FOR PIN 1 ORIENTATION IN TAPE**

\*All dimensions are nominal

Device	Package Type	Package Drawing	Pins	SPQ	Reel Diameter (mm)	Reel Width W1 (mm)	A0 (mm)	B0 (mm)	K0 (mm)	P1 (mm)	W (mm)	Pin1 Quadrant
TPS54428DDAR	SO Power PAD	DDA	8	2500	330.0	12.8	6.4	5.2	2.1	8.0	12.0	Q1
TPS54428DRCR	VSON	DRC	10	3000	330.0	12.4	3.3	3.3	1.1	8.0	12.0	Q2
TPS54428DRCT	VSON	DRC	10	250	180.0	12.4	3.3	3.3	1.1	8.0	12.0	Q2

**TAPE AND REEL BOX DIMENSIONS**



\*All dimensions are nominal

Device	Package Type	Package Drawing	Pins	SPQ	Length (mm)	Width (mm)	Height (mm)
TPS54428DDAR	SO PowerPAD	DDA	8	2500	366.0	364.0	50.0
TPS54428DRCR	VSON	DRC	10	3000	367.0	367.0	35.0
TPS54428DRCT	VSON	DRC	10	250	210.0	185.0	35.0

**TUBE**

\*All dimensions are nominal

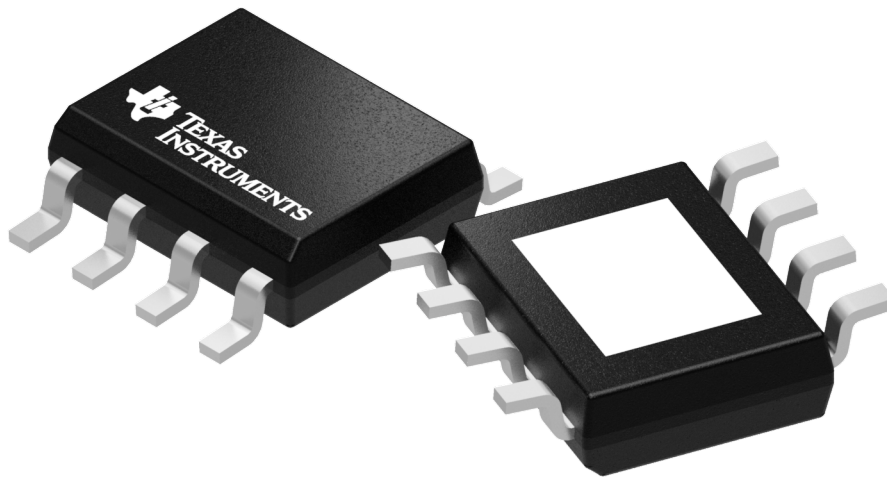
Device	Package Name	Package Type	Pins	SPQ	L (mm)	W (mm)	T (μm)	B (mm)
TPS54428DDA	DDA	HSOIC	8	75	508	7.77	2540	NA
TPS54428DDA	DDA	HSOIC	8	75	517	7.87	635	4.25



Images above are just a representation of the package family, actual package may vary.  
Refer to the product data sheet for package details.

DDA (R-PDSO-G8)

PowerPAD™ PLASTIC SMALL-OUTLINE

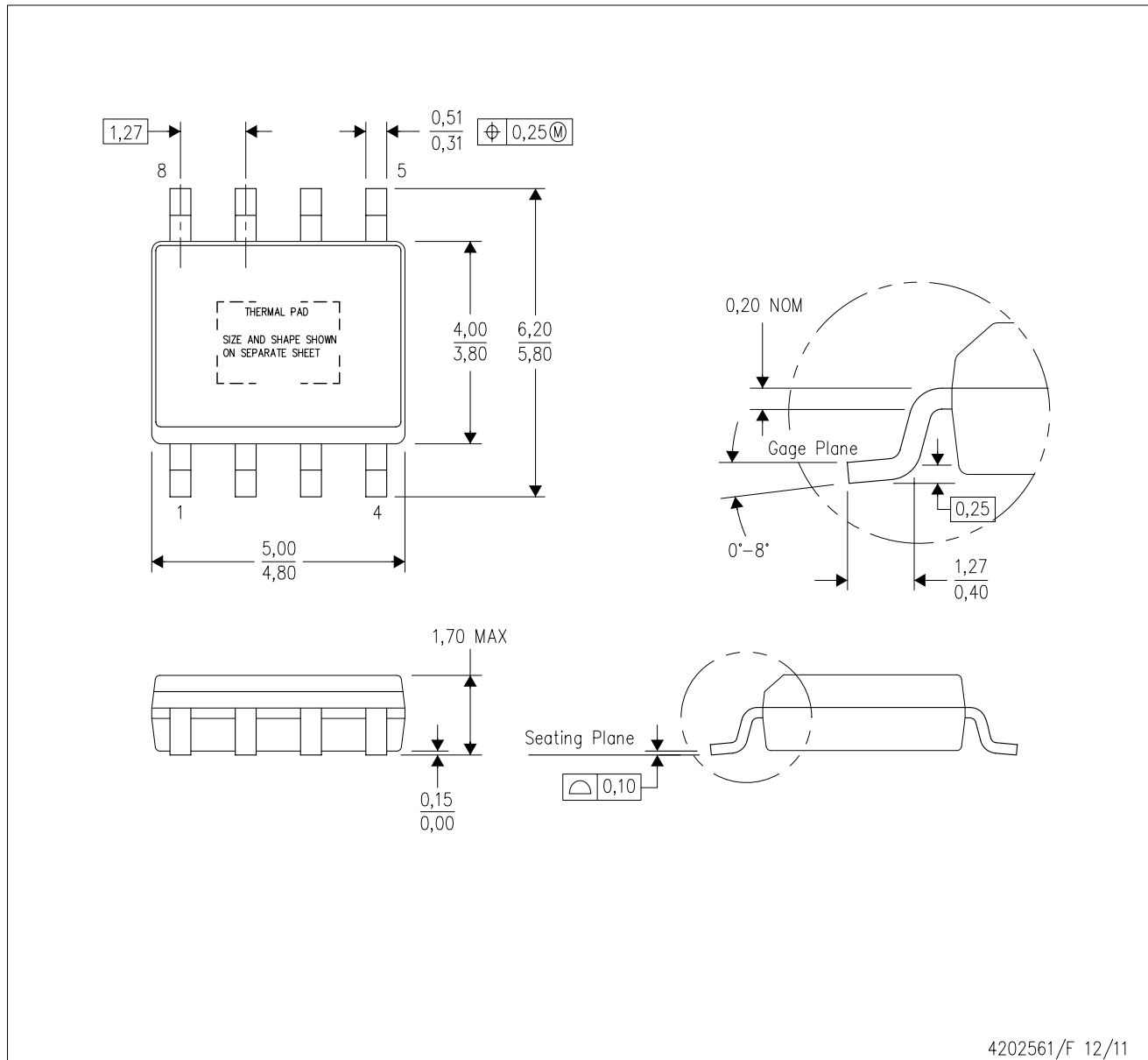

4202561/F 12/11

- NOTES:
- All linear dimensions are in millimeters. Dimensioning and tolerancing per ASME Y14.5-1994.
  - This drawing is subject to change without notice.
  - Body dimensions do not include mold flash or protrusion not to exceed 0,15.
  - This package is designed to be soldered to a thermal pad on the board. Refer to Technical Brief, PowerPad Thermally Enhanced Package, Texas Instruments Literature No. SLMA002 for information regarding recommended board layout. This document is available at [www.ti.com](http://www.ti.com) <<http://www.ti.com>>.
  - See the additional figure in the Product Data Sheet for details regarding the exposed thermal pad features and dimensions.
  - This package complies to JEDEC MS-012 variation BA

PowerPAD is a trademark of Texas Instruments.

DDA (R-PDSO-G8)

PowerPAD™ PLASTIC SMALL OUTLINE

## THERMAL INFORMATION

This PowerPAD™ package incorporates an exposed thermal pad that is designed to be attached to a printed circuit board (PCB). The thermal pad must be soldered directly to the PCB. After soldering, the PCB can be used as a heatsink. In addition, through the use of thermal vias, the thermal pad can be attached directly to the appropriate copper plane shown in the electrical schematic for the device, or alternatively, can be attached to a special heatsink structure designed into the PCB. This design optimizes the heat transfer from the integrated circuit (IC).

For additional information on the PowerPAD package and how to take advantage of its heat dissipating abilities, refer to Technical Brief, PowerPAD Thermally Enhanced Package, Texas Instruments Literature No. SLMA002 and Application Brief, PowerPAD Made Easy, Texas Instruments Literature No. SLMA004. Both documents are available at [www.ti.com](http://www.ti.com).

The exposed thermal pad dimensions for this package are shown in the following illustration.

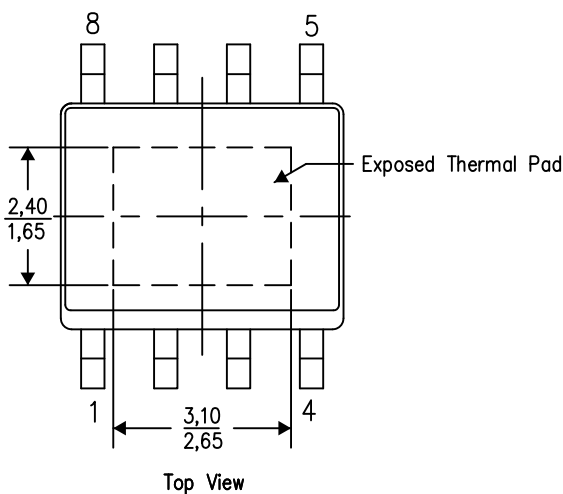

Exposed Thermal Pad Dimensions

4206322-6/L 05/12

NOTE: A. All linear dimensions are in millimeters

PowerPAD is a trademark of Texas Instruments

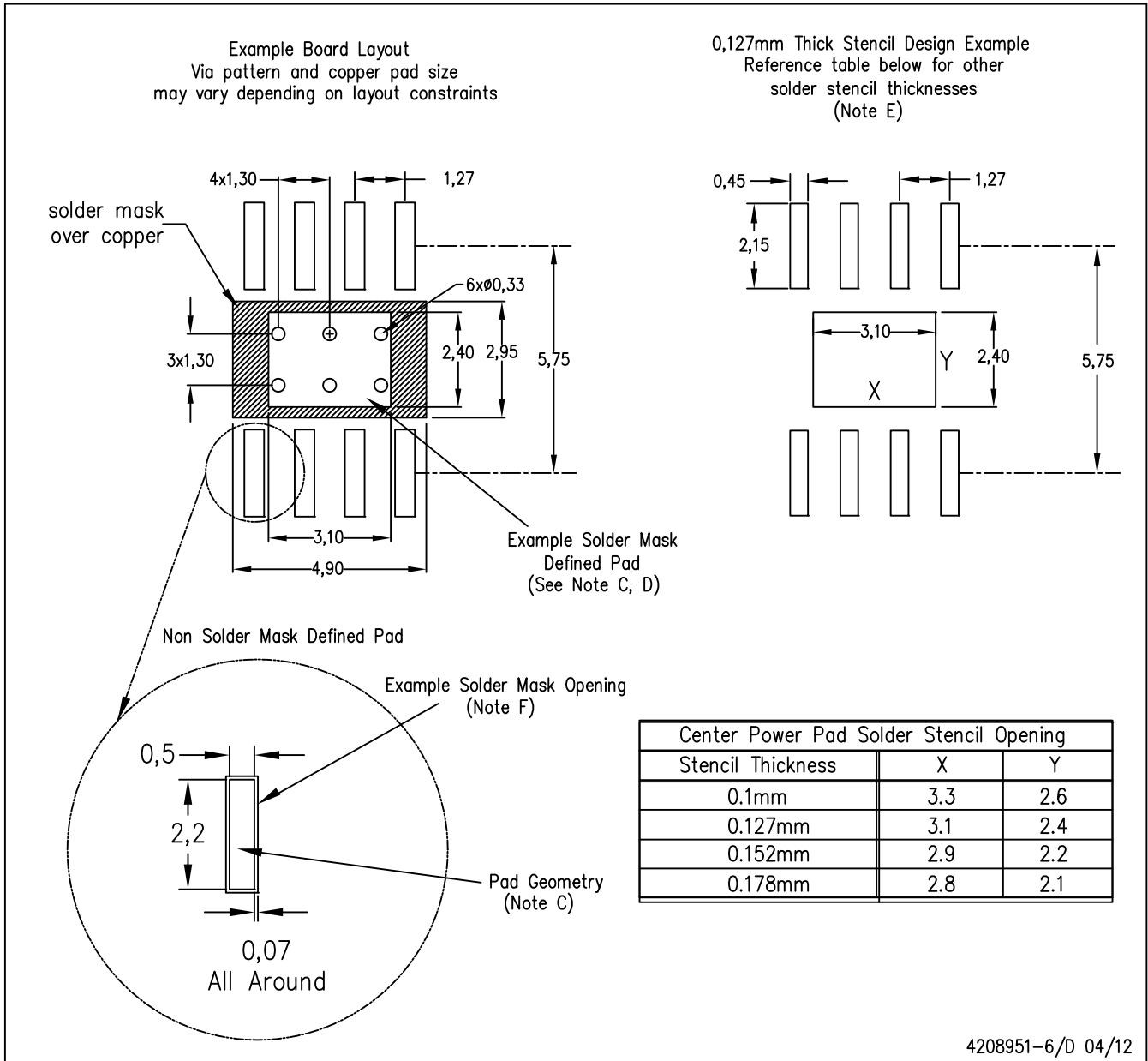

- NOTES:
- A. All linear dimensions are in millimeters.
  - B. This drawing is subject to change without notice.
  - C. Publication IPC-7351 is recommended for alternate designs.
  - D. This package is designed to be soldered to a thermal pad on the board. Refer to Technical Brief, PowerPad Thermally Enhanced Package, Texas Instruments Literature No. SLMA002, SLMA004, and also the Product Data Sheets for specific thermal information, via requirements, and recommended board layout. These documents are available at [www.ti.com](http://www.ti.com) <<http://www.ti.com>>. Publication IPC-7351 is recommended for alternate designs.
  - E. Laser cutting apertures with trapezoidal walls and also rounding corners will offer better paste release. Customers should contact their board assembly site for stencil design recommendations. Example stencil design based on a 50% volumetric metal load solder paste. Refer to IPC-7525 for other stencil recommendations.
  - F. Customers should contact their board fabrication site for solder mask tolerances between and around signal pads.

PowerPAD is a trademark of Texas Instruments.

## GENERIC PACKAGE VIEW

**DRC 10**

**VSON - 1 mm max height**

3 x 3, 0.5 mm pitch

PLASTIC SMALL OUTLINE - NO LEAD

This image is a representation of the package family, actual package may vary.  
Refer to the product data sheet for package details.

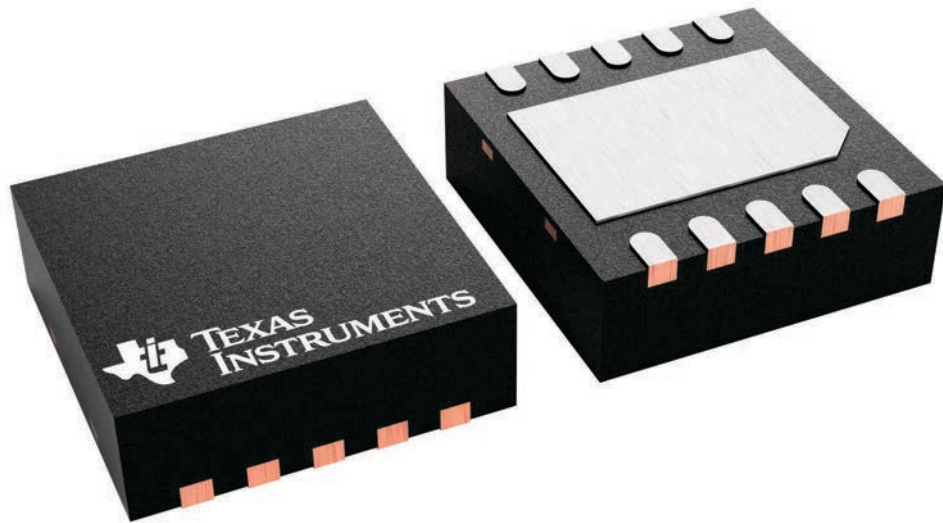

4226193/A



# EXAMPLE BOARD LAYOUT

DRC0010J

VSON - 1 mm max height

PLASTIC SMALL OUTLINE - NO LEAD



LAND PATTERN EXAMPLE  
EXPOSED METAL SHOWN  
SCALE:20X



SOLDER MASK DETAILS

4218878/B 07/2018

NOTES: (continued)

4. This package is designed to be soldered to a thermal pad on the board. For more information, see Texas Instruments literature number SLUA271 ([www.ti.com/lit/slua271](http://www.ti.com/lit/slua271)).
5. Vias are optional depending on application, refer to device data sheet. If any vias are implemented, refer to their locations shown on this view. It is recommended that vias under paste be filled, plugged or tented.

# EXAMPLE STENCIL DESIGN

DRC0010J

VSON - 1 mm max height

PLASTIC SMALL OUTLINE - NO LEAD

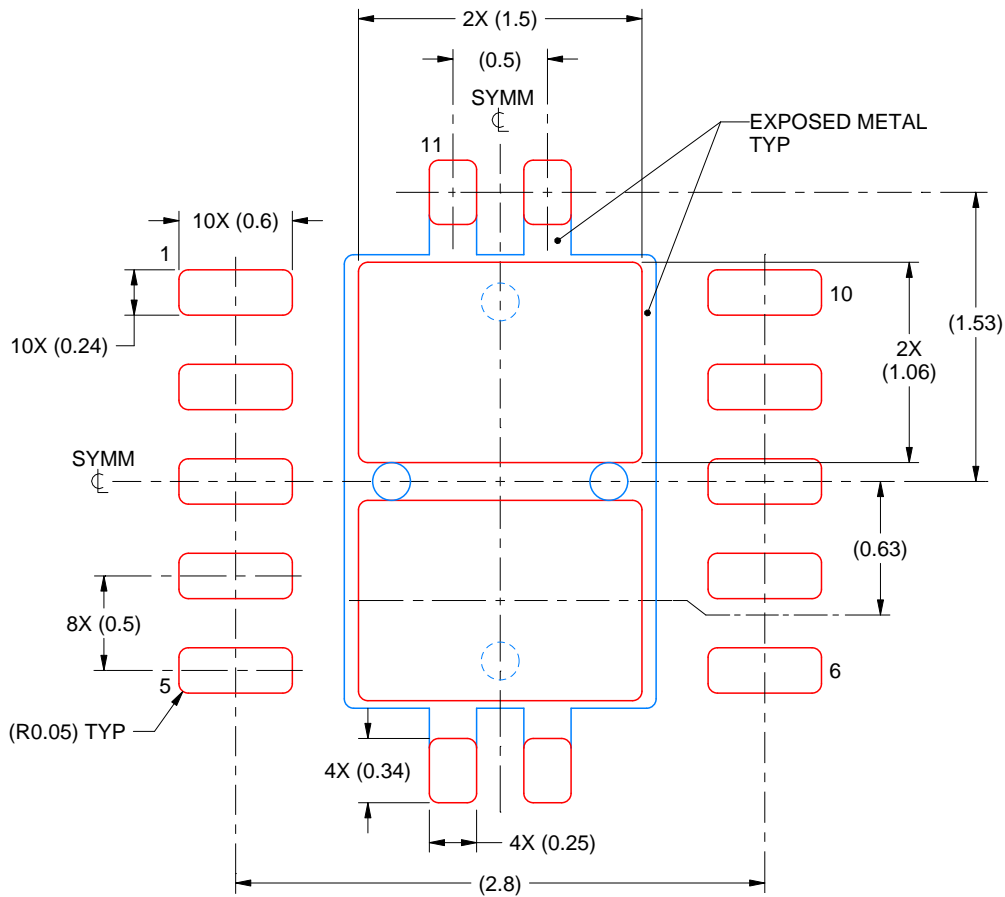

SOLDER PASTE EXAMPLE  
BASED ON 0.125 mm THICK STENCIL

EXPOSED PAD 11:  
80% PRINTED SOLDER COVERAGE BY AREA  
SCALE:25X

4218878/B 07/2018

NOTES: (continued)

6. Laser cutting apertures with trapezoidal walls and rounded corners may offer better paste release. IPC-7525 may have alternate design recommendations.

## 重要声明和免责声明

TI“按原样”提供技术和可靠性数据（包括数据表）、设计资源（包括参考设计）、应用或其他设计建议、网络工具、安全信息和其他资源，不保证没有瑕疵且不做任何明示或暗示的担保，包括但不限于对适销性、某特定用途方面的适用性或不侵犯任何第三方知识产权的暗示担保。

这些资源可供使用 TI 产品进行设计的熟练开发人员使用。您将自行承担以下全部责任：(1) 针对您的应用选择合适的 TI 产品，(2) 设计、验证并测试您的应用，(3) 确保您的应用满足相应标准以及任何其他功能安全、信息安全、监管或其他要求。

这些资源如有变更，恕不另行通知。TI 授权您仅可将这些资源用于研发本资源所述的 TI 产品的应用。严禁对这些资源进行其他复制或展示。您无权使用任何其他 TI 知识产权或任何第三方知识产权。您应全额赔偿因在这些资源的使用中对 TI 及其代表造成的任何索赔、损害、成本、损失和债务，TI 对此概不负责。

TI 提供的产品受 [TI 的销售条款](#) 或 [ti.com](#) 上其他适用条款/TI 产品随附的其他适用条款的约束。TI 提供这些资源并不会扩展或以其他方式更改 TI 针对 TI 产品发布的适用的担保或担保免责声明。

TI 反对并拒绝您可能提出的任何其他或不同的条款。

邮寄地址：Texas Instruments, Post Office Box 655303, Dallas, Texas 75265

Copyright © 2022，德州仪器 (TI) 公司