

TPS6120x 具有 1.3A 开关的低输入电压同步升压转换器

1 特性

- 下列条件下效率高于 90%:
 - 3.3V
300mA 输出电流, 3.3V ($V_{IN} \geq 2.4V$) 时
 - 5V 时的输出电流为 600mA ($V_{IN} \geq 3V$)
- 在升压模式和降压转换模式之间自动转换
- 器件的静态电流小于 50 μ A
- 在输入电压为 0.5V 时启动进入满负荷
- 工作输入电压范围从 0.3V 至 5.5V
- 可编程欠压闭锁阈值
- 所有工作条件下的输出短路保护
- 1.8V 至 5.5V 固定和可调输出电压选项
- 节能模式, 用于改进低输出功率时的效率
- 可强制固定运行频率
- 关机期间负载断开
- 过温保护
- 小型 3 mm x 3 mm VSON-10 封装

2 应用范围

- 所有单节、两节和三节碱性、镍镉或镍氢电池或单节锂电池供电类产品
- 燃料电池和太阳能电池供电类产品
- 便携式音频播放器
- 掌上电脑 (PDA)
- 手机
- 个人医疗产品
- 白光 LED 驱动器

4 典型应用

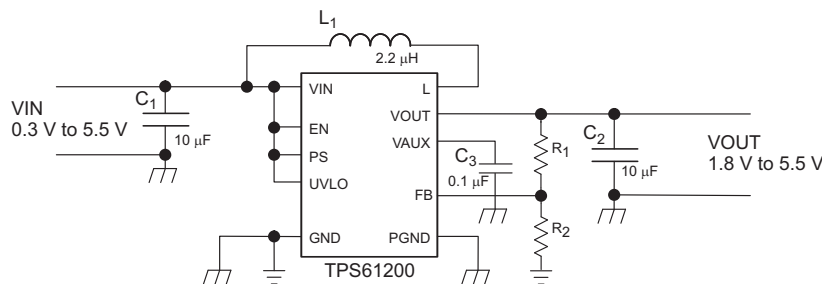

3 说明

TPS6120x 器件可以为由单节、2 节或 3 节碱性、镍镉或镍氢电池或单节锂离子或锂聚合物电池供电的产品提供电源解决方案。它也被用在燃料电池或太阳能电池供电的器件中, 在此类应用中处理低输入电压的能力十分重要。可能的输出电流取决于输入与输出电压比。在使用一个单节锂离子或锂聚合物电池并且将其放电至 2.6V 时, 此器件在 5V 输出时提供高达 600mA 的输出电流。此升压控制器基于一个固定频率、脉宽调制 (PWM) 控制器, 此控制器使用同步整流来获得最大效率。在低负载电流情况下, 此转换器进入省电模式以在宽负载电流范围内保持高效率。省电模式可被禁用, 从而强制转换器运行在固定的开关频率下。平均输入电流被限制在 1500mA 的最大值上。通过一个外部电阻器分压器可对输出电压进行编程, 或者在芯片上对输出电压进行内部固定。转换器可被禁用以大大减少电池消耗。在关断期间, 负载从电池上完全断开。此器件采用 10 引脚 3 mm x 3 mm VSON 封装。

器件信息⁽¹⁾

器件型号	封装	封装尺寸 (标称值)
TPS6120x	VSON (10)	3.00mm x 3.00mm

(1) 要了解所有可用封装, 请见数据表末尾的可订购产品附录。



目录

1	特性	1	10.2	Functional Block Diagram	11
2	应用范围	1	10.3	Feature Description	12
3	说明	1	10.4	Device Functional Modes	13
4	典型应用	1	11	Application and Implementation	14
5	修订历史记录	2	11.1	Application Information	14
6	Device Options	4	11.2	Typical Application	14
7	Pin Configuration and Functions	4	11.3	System Examples	19
8	Specifications	5	12	Power Supply Recommendations	20
8.1	Absolute Maximum Ratings	5	13	Layout	21
8.2	ESD Ratings	5	13.1	Layout Guidelines	21
8.3	Recommended Operating Conditions	5	13.2	Layout Example	21
8.4	Thermal Information	5	13.3	Thermal Considerations	21
8.5	Electrical Characteristics	6	14	器件和文档支持	22
8.6	Typical Characteristics	7	14.1	相关链接	22
9	Parameter Measurement Information	10	14.2	商标	22
10	Detailed Description	11	14.3	静电放电警告	22
10.1	Overview	11	14.4	术语表	22
			15	机械、封装和可订购信息	22

5 修订历史记录

注：之前版本的页码可能与当前版本有所不同。

Changes from Revision D (March 2013) to Revision E	Page
• 已添加 ESD 额定值表，特性 描述部分，器件功能模式，应用和实施部分，电源相关建议部分，布局部分，器件和文档支持部分以及机械、封装和可订购信息部分	1

Changes from Revision C (September 2012) to Revision D	Page
• Changed the PS pin description From: Enable/disable Power Save mode (High = enabled, Low = disabled) To: Enable/disable Power Save mode (High = disabled, Low = enabled)	4

Changes from Revision B (FEBRUARY 2008) to Revision C	Page
• 已将特性从“小型 3mm x 3mm QFN-10 封装”改为“小型 3mm x 3mm SON-10 封装”	1
• 将应用从：白光 LED 改为：白光 LED 驱动器	1
• Changed the Available Device Options Package type From: 10-PIN QFN To: 10-Pin SON	4
• Changed V_{SS} to V_{IN} in the Recommended Operating Conditions table	5
• Changed From: DISSIPATION RATINGS TABLE To: Thermal Information table	5
• Changed the Parameters and Test Conditions in the Electrical Characteristics table	6
• Updated 图 1 through 图 11	7
• Added C3 to the List of Components	14
• Added text to the Input Capacitor section "An R-C filter may be placed..."	16
• Added 图 26, 图 27, and 图 28	19
• Added 图 29	21

Changes from Revision A (JUNE 2007) to Revision B	Page
• Added DSC package and tape and reel note to the Available Device Options.	4

Changes from Original (MARCH 2007) to Revision A**Page**

• 已更改 特性 要点从“600mA 输出电流, 3.3V (VIN ≥ 1.2V) 时”改为“300mA 输出电流, 3.3V (VIN ≥ 2.4V) 时”	1
• 已更改 图 6 label From: Power Save Disabled To: Power Save Enabled	7
• 已更改 图 7 label From: Power Save Enabled To: Power Save Disabled	8

6 Device Options

T _A	OUTPUT VOLTAGE ⁽¹⁾	PART NUMBER ⁽²⁾
–40°C to 85°C	Adjustable	TPS61200DRC
	3.3 V	TPS61201DRC
	5 V	TPS61202DRC
	5 V	TPS61202DSC

- (1) Contact the factory to check availability of other fixed output voltage versions.
 (2) The DRC and the DSC package are available taped and reeled. Add R suffix to device type (e.g., TPS61200DRCR or TPS61202DSCR) to order quantities of 3000 devices per reel. It is also available in minireels. Add a T suffix to the device type (i.e. TPS61200DRCT or TPS61202DSCT) to order quantities of 250 devices per reel.

7 Pin Configuration and Functions

DSC and DRC Package
 10 Pins
 Top View

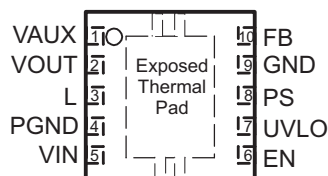

Pin Functions

PIN		I/O	DESCRIPTION
NAME	NO.		
EN	6	I	Enable input (High = enabled, Low = disabled). Do not leave floating.
Exposed thermal pad	—	—	Must be soldered to achieve appropriate power dissipation and mechanical reliability. Should be connected to PGND.
FB	10	I	Voltage feedback of adjustable versions, must be connected to V _{OUT} at fixed output voltage versions
GND	9	—	Control / logic ground
PGND	4	—	Power ground
PS	8	I	Enable/disable Power Save mode (High = disabled, Low = enabled). Do not leave floating.
L	3	I	Connection for Inductor
UVLO	7	I	Undervoltage lockout comparator input. Must be connected to VAUX if not used
VAUX	1	I/O	Supply voltage for control stage
VIN	5	I	Boost converter input voltage
VOUT	2	O	Boost converter output

8 Specifications

8.1 Absolute Maximum Ratings

over operating free-air temperature range (unless otherwise noted)⁽¹⁾

		MIN	MAX	UNIT
V _{IN}	Input voltage range on VIN, L, VAUX, VOUT, PS, EN, FB, UVLO	-0.3	7	V
T _J	Operating junction temperature	-40	150	°C
T _{stg}	Storage temperature	-65	150	°C

- (1) Stresses beyond those listed under *Absolute Maximum Ratings* may cause permanent damage to the device. These are stress ratings only, and functional operation of the device at these or any other conditions beyond those indicated under *Recommended Operating Conditions* is not implied. Exposure to absolute-maximum-rated conditions for extended periods may affect device reliability.

8.2 ESD Ratings

		VALUE	UNIT
V _(ESD)	Electrostatic discharge	Human-body model (HBM), per ANSI/ESDA/JEDEC JS-001 ⁽¹⁾	±4000
		Charged-device model (CDM), per JEDEC specification JESD22-C101 ⁽²⁾	±1500
		Machine Model (MM) ⁽³⁾	±200

- (1) JEDEC document JEP155 states that 500-V HBM allows safe manufacturing with a standard ESD control process. Manufacturing with less than 500-V HBM is possible with the necessary precautions.
(2) JEDEC document JEP157 states that 250-V CDM allows safe manufacturing with a standard ESD control process. Manufacturing with less than 250-V CDM is possible with the necessary precautions.
(3) ESD testing is performed according to the respective JESD22 JEDEC standard.

8.3 Recommended Operating Conditions

		MIN	NOM	MAX	UNIT
V _{IN}	Input voltage at VIN	0.3		5.5	V
T _A	Operating free air temperature range	-40		85	°C
T _J	Operating junction temperature range	-40		125	°C

8.4 Thermal Information

THERMAL METRIC ⁽¹⁾	TPS6120x		UNIT	
	DRC	DSC		
	10 PINS	10 PINS		
R _{θJA}	Junction-to-ambient thermal resistance	41.2	40.4	°C/W
R _{θJC(top)}	Junction-to-case (top) thermal resistance	62.8	37.8	
R _{θJB}	Junction-to-board thermal resistance	16.6	15.4	
ψ _{JT}	Junction-to-top characterization parameter	1.2	0.3	
ψ _{JB}	Junction-to-board characterization parameter	16.8	15.6	
R _{θJC(bot)}	Junction-to-case (bottom) thermal resistance	4.1	2.8	

- (1) For more information about traditional and new thermal metrics, see the *IC Package Thermal Metrics* application report, [SPRA953](#).

8.5 Electrical Characteristics

over recommended junction temperature range and over recommended input voltage range (typical at an ambient temperature range of 25°C) (unless otherwise noted)

PARAMETER		TEST CONDITIONS	MIN	TYP	MAX	UNIT	
DC-DC STAGE							
V_{IN}	Input voltage range		0.3		5.5	V	
V_{IN}	Minimum input voltage at startup				0.5	V	
V_{OUT}	TPS61200 output voltage range		1.8		5.5	V	
V_{FB}	TPS61200 feedback voltage		495	500	505	mV	
V_{OUT}	TPS61201 output voltage	$V_{IN} < V_{OUT}$, PS = High	3.27	3.3	3.33	V	
V_{OUT}	TPS61202 output voltage	$V_{IN} < V_{OUT}$, PS = High	4.95	5.0	5.05	V	
f	Oscillator frequency		1250		1650	kHz	
I_{LIM}	average inductor current limit	$V_{OUT} = 3.3$ V	1200	1350	1500	mA	
$R_{DS(on)}$	Rectifying switch on resistance	$V_{OUT} = 3.3$ V		180		mΩ	
$R_{DS(on)}$	Main switch on resistance	$V_{OUT} = 3.3$ V		150		mΩ	
	Line regulation	$V_{IN} < V_{OUT}$, PS = High		0.1%	0.5%		
	Load regulation	$V_{IN} < V_{OUT}$, PS = High		0.1%	0.5%		
I_Q	Quiescent current	V_{IN}	$I_O = 0$ mA, $V_{EN} = V_{IN} = 1.2$ V, $V_{OUT} = 3.3$ V, $V_{AUX} = 3.3$ V PS = Low		1	2	μA
		V_{OUT}			50	70	μA
		V_{AUX}			4	6	μA
I_{SD}	Shutdown current	V_{IN}	$V_{EN} = 0$ V, $V_{IN} = 1.2$ V		0.5	1.5	μA
		V_{AUX}			1	2	μA
I_{LKG}	Input leakage current (L)	$V_{EN} = 0$ V, $V_{IN} = 1.2$ V, $V_L = 1.2$ V		0.01	1	μA	
CONTROL STAGE							
V_{AUX}	Auxiliary Output Voltage		2.4		5.5	V	
V_{IL}	Low level input threshold voltage (EN)	$V_{IN} < 0.8$ V			$0.1 \times V_{IN}$	V	
V_{IH}	High level input threshold voltage (EN)	$V_{IN} < 0.8$ V	$0.9 \times V_{IN}$			V	
V_{IL}	Low level input threshold voltage (EN)	0.8 V $\leq V_{IN} \leq 1.5$ V			$0.2 \times V_{IN}$	V	
V_{IH}	High level input threshold voltage (EN)	0.8 V $\leq V_{IN} \leq 1.5$ V	$0.8 \times V_{IN}$			V	
V_{IL}	Low level input threshold voltage (EN)	$V_{IN} > 1.5$ V			0.4	V	
V_{IH}	High level input threshold voltage (EN)	$V_{IN} > 1.5$ V	1.2			V	
V_{IL}	Low level input threshold voltage (PS)				0.4	V	
V_{IH}	High level input threshold voltage (PS)		1.2			V	
I_{LKG}	Input leakage current (EN, PS)	EN, PS = GND or V_{IN}		0.01	0.1	μA	
V_{UVLO}	Undervoltage lockout threshold	Falling UVLO voltage	235	250	265	mV	
V_{UVLO}	Undervoltage lockout threshold	Rising UVLO voltage	330	350	370	mV	
I_{LKG}	Input leakage current (UVLO)	$V_{UVLO} = 0.5$ V			0.3	μA	
V_{OVP}	Overvoltage protection threshold		5.5		7	V	
	Thermal shutdown temperature	Rising temperature		140		°C	
	Thermal shutdown temperature hysteresis			20		°C	

8.6 Typical Characteristics

表 1. Table of Graphs

		FIGURE
Maximum output current	vs Input voltage	图 1
Efficiency	vs Output current (TPS61200), Power Save Enabled	图 2
	vs Output current (TPS61200), Power Save Disabled	图 3
	vs Output current (TPS61201), Power Save Enabled	图 4
	vs Output current (TPS61201), Power Save Disabled	图 5
	vs Output current (TPS61202), Power Save Enabled	图 6
	vs Output current (TPS61202), Power Save Disabled	图 7
	vs Input voltage (TPS61201), Power Save Enabled	图 8
	vs Input voltage (TPS61201), Power Save Disabled	图 9
	vs Input voltage (TPS61202), Power Save Enabled	图 10
	vs Input voltage (TPS61202), Power Save Disabled	图 11
Output voltage	vs Output current (TPS61201)	图 12
	vs Output current (TPS61202)	图 13

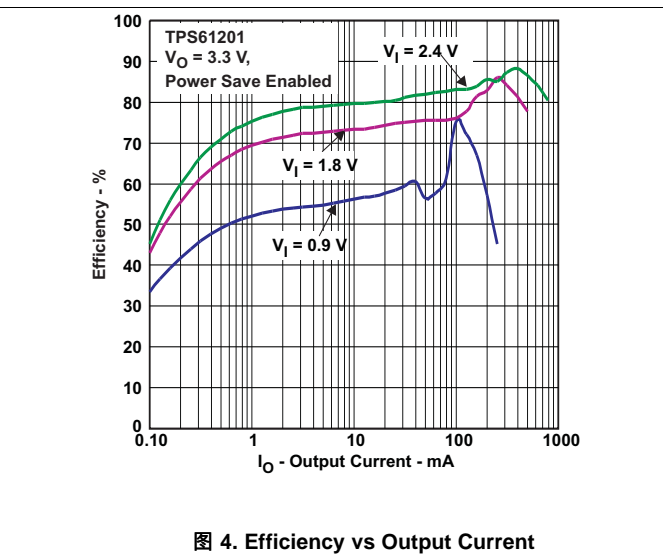
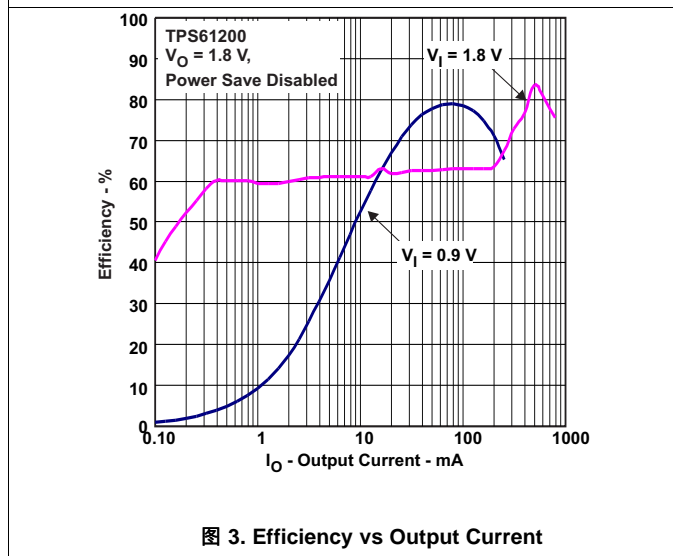
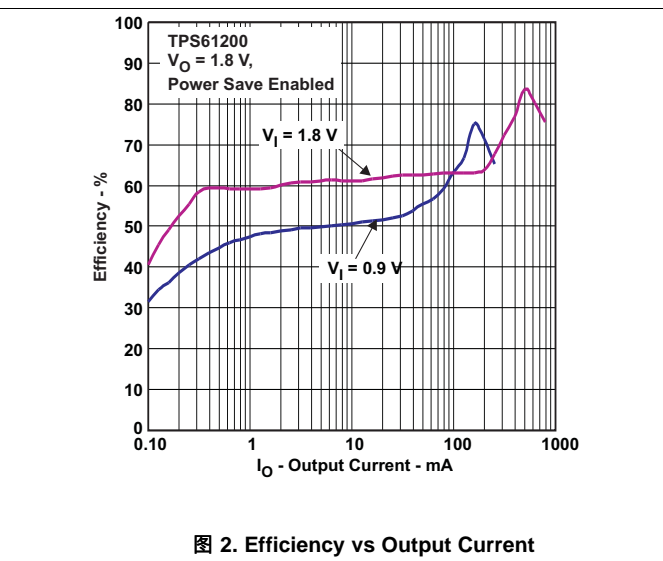
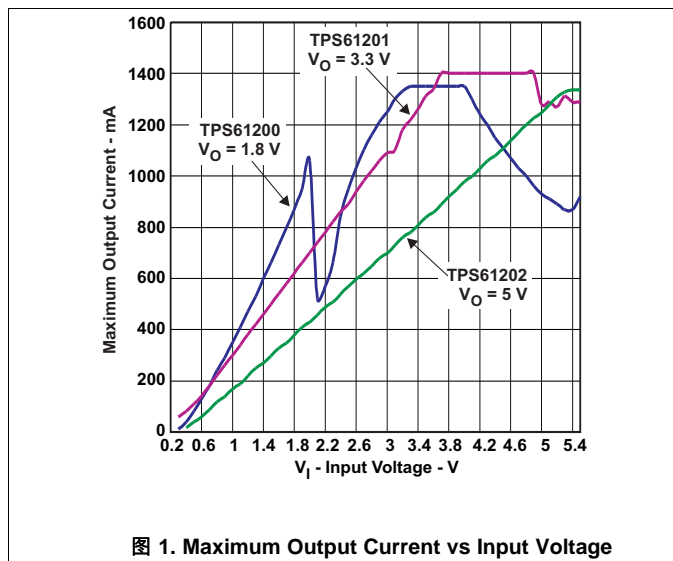



图 5. Efficiency vs Output Current



图 6. Efficiency vs Output Current

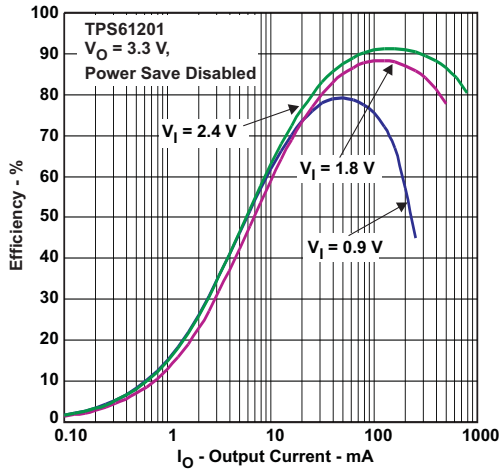

图 7. Efficiency vs Output Current

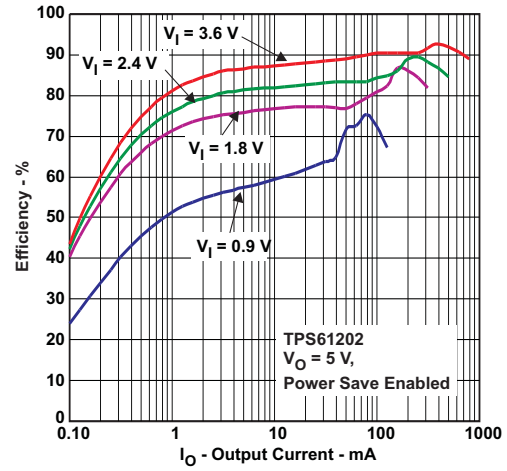

图 8. Efficiency vs Input Voltage

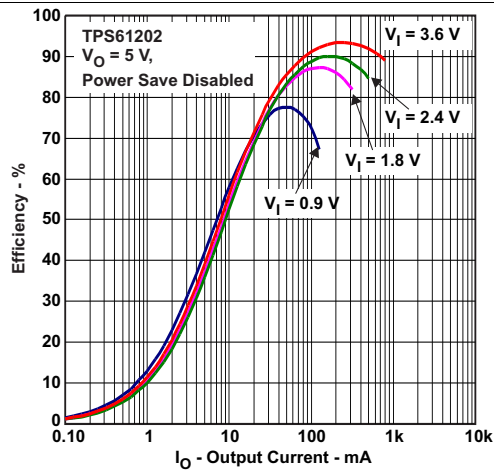

图 9. Efficiency vs Input Voltage

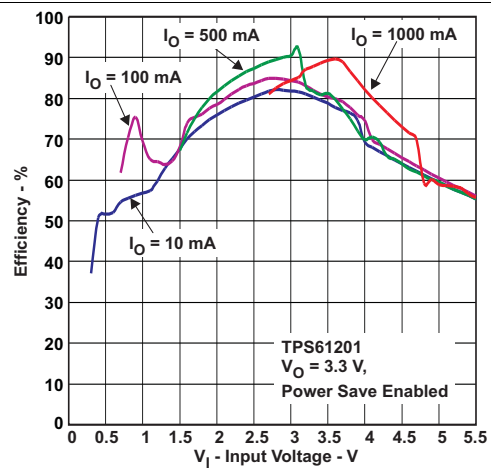

图 10. Efficiency vs Input Voltage

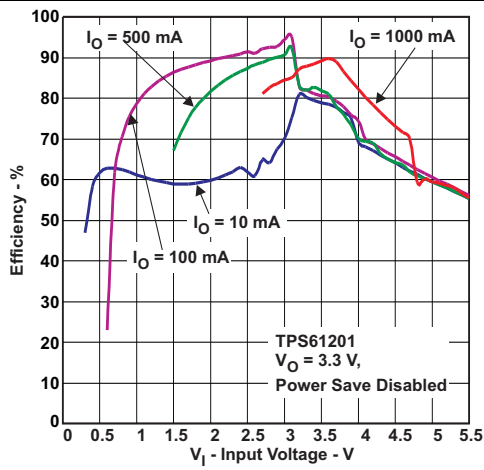

图 11. Efficiency vs Input Voltage

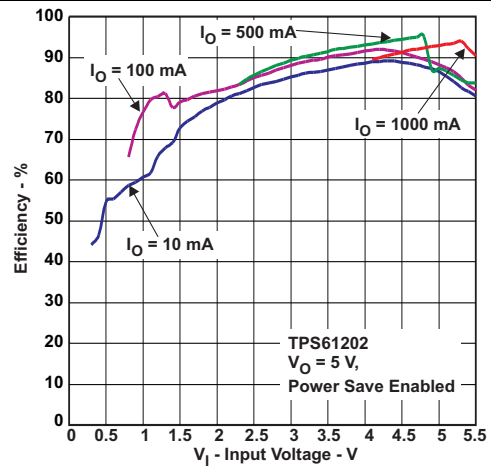

图 12. Output Voltage vs Output Current

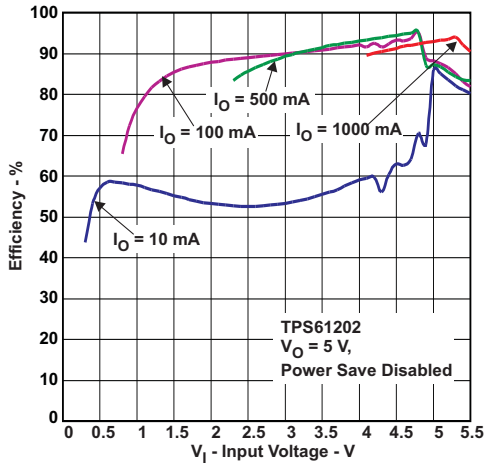

图 13. Output Voltage vs Output Current

9 Parameter Measurement Information

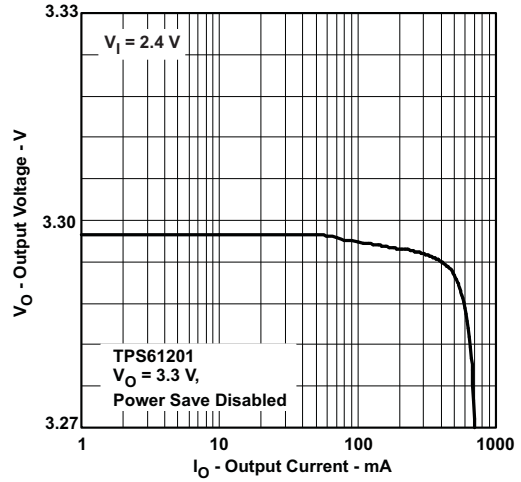

图 14. Parameter Measurement Schematic

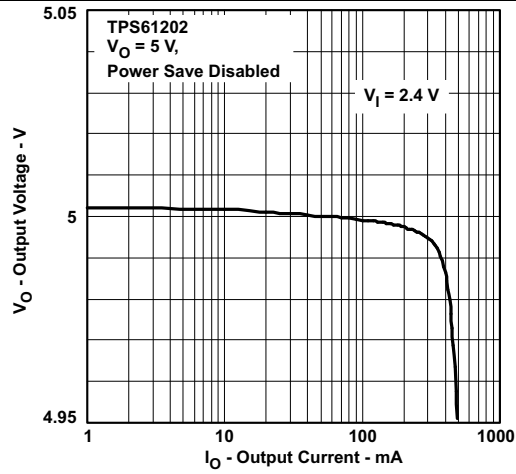
10 Detailed Description

10.1 Overview

The TPS6120x is a low input voltage synchronous boost converter family. The devices support 0.3-V to 5.5-V input voltage range, so can provide power supply solutions for products powered by either a single-cell, two-cell, or three-cell alkaline, NiCd or NiMH, or one-cell Li-Ion or Li-polymer battery. It is also used in fuel cell or solar cell powered devices where the capability of handling low input voltages is essential. The devices provide output currents of up to 600 mA at a 5-V output, while using a single-cell Li-Ion or Li-Polymer battery and discharges it down to 2.6 V. The boost converter is based on a fixed frequency, pulse-width-modulation (PWM) controller using synchronous rectification to obtain maximum efficiency. At low load currents, the converter enters the Power Save mode to maintain a high efficiency over a wide load current range. The Power Save mode can be disabled, forcing the converter to operate at a fixed switching frequency. The average input current is limited to a maximum value of 1500 mA. The output voltage is programmed by an external resistor divider, or is fixed internally on the chip. The converter can be disabled to minimize battery drain. During shutdown, the load is completely disconnected from the battery.

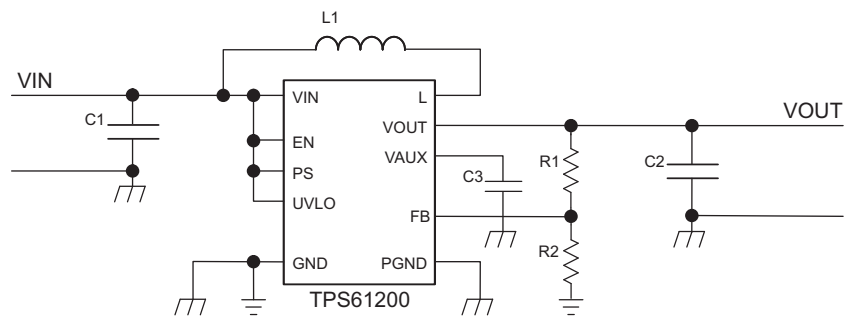
10.2 Functional Block Diagram

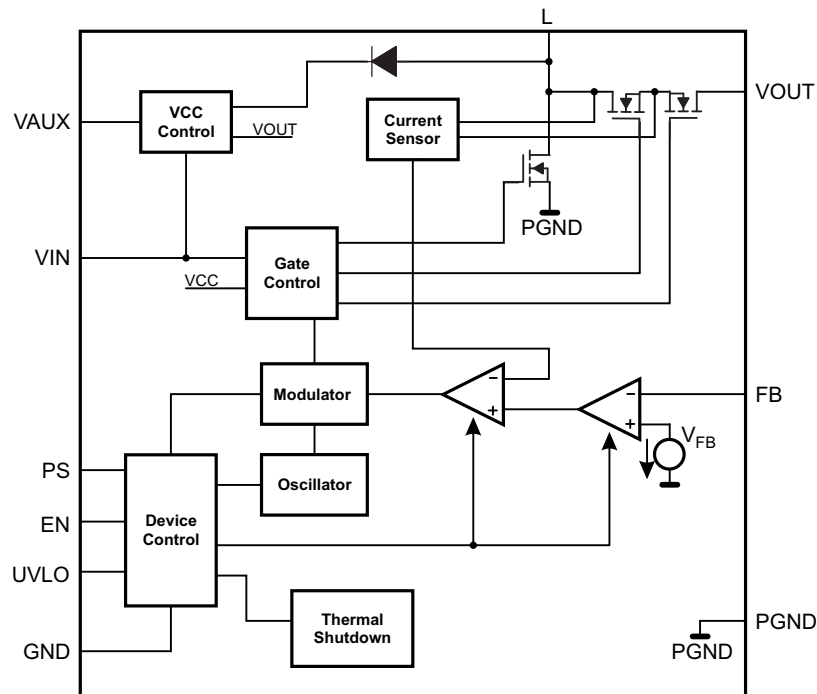

10.3 Feature Description

10.3.1 Controller Circuit

The controlling circuit of the device is based on an average current mode topology. The average inductor current is regulated by a fast current regulator loop which is controlled by a voltage control loop. The controller also uses input and output voltage feedforward. Changes of input and output voltage are monitored and immediately change the duty cycle in the modulator to achieve a fast response to those errors. The voltage error amplifier gets its feedback input from the FB pin. For adjustable output voltage devices, a resistive voltage divider must be connected to that pin. For fixed output voltage devices, FB must be connected to the output voltage to directly sense the voltage. Fixed output voltage versions use a trimmed internal resistive divider. The feedback voltage is compared with the internal reference voltage to generate a stable and accurate output voltage.

The controller circuit also senses the average input current as well as the peak input current. Thus, the maximum input power is controlled as well as the maximum peak current, to achieve a safe and stable operation under all possible conditions. To protect the device from overheating, an internal temperature sensor is implemented.

10.3.1.1 Synchronous Operation

The device uses three internal N-channel MOSFETs to maintain synchronous power conversion at all possible operating conditions. This enables the device to keep high efficiency over a wide input voltage and output power range.

To avoid ground shift problems due to the high currents in the switches, two separate ground pins, GND and PGND, are used. The reference for all control functions is the GND pin. The power switches are connected to PGND. Both grounds must be connected on the PCB at only one point, ideally close to the GND pin. Due to the 3-switch topology, the load is always disconnected from the input during shutdown of the converter.

10.3.1.2 Down Regulation

A boost converter only regulates output voltages which are higher than the input voltage. This device operates differently. For example, it is able to regulate 3 V at the output with two fresh alkaline cells at the input having a total cell voltage of 3.2 V. Another example is powering white LEDs with a forward voltage of 3.6 V from a fully charged Li-Ion cell with an output voltage of 4.2 V. To control these applications properly, a Down Conversion mode is implemented.

If the input voltage reaches or exceeds the output voltage, the converter automatically changes to a Down Conversion mode. In this mode, the control circuit changes the behavior of the two rectifying switches. While continuing switching, it sets the voltage drop across the rectifying switches as high as needed to regulate the output voltage. This means the power losses in the converter increase. This must be taken into account for thermal consideration.

10.3.1.3 Device Enable

The device is put into operation when EN is set high. It is put into Shutdown mode when EN is set to low. In Shutdown mode, the regulator stops switching, all internal control circuitry including the UVLO comparator is switched off, and the load is disconnected from the input. Current does not flow from input to output or from output to input. This also means that the output voltage can drop below the input voltage during shutdown.

10.3.1.4 Softstart and Short-Circuit Protection

During start-up of the converter, the duty cycle and the peak current are limited in order to avoid high peak currents drawn from the battery. After being enabled, the device starts operating. At first, it keeps the main output VOUT disconnected, and charges the capacitor at VAUX. Once the capacitor at VAUX is charged to about 2.5 V, the device switches to normal operation. This means VOUT is turned on and the capacitor at VOUT is charged, while the load connected to the device is supplied. To ramp up the output voltage in a controlled way, the average current limit is set to 400 mA and rises proportional to the increase of the output voltage. At an output voltage of about 1.2 V the current limit is at its nominal value. If the output voltage does not increase, the current limit does not increase. There is no timer implemented. Thus the output voltage overshoot at startup, as well as the inrush current, is kept at a minimum. The device ramps up the output voltage in a controlled manner even if a large capacitor is connected at the output. When the output voltage does not increase above 1.2 V, the device assumes a short-circuit at the output, and keeps the current limit low to protect itself and the application. When there is a short at the output during operation, the current limit is decreased accordingly.

Feature Description (接下页)

The device can also start into a Prebias on the outputs.

10.3.1.5 Current Limit

The device current limit limits the average current in the inductor. In a boost connector, this is the input current. If an excessive load requires an input current greater than the average current limit, the device limits the input current by reducing the output power delivered. In this case, the output voltage decreases.

10.3.1.6 Undervoltage Lockout

An undervoltage lockout function prevents the main output at VOUT from being supplied if the voltage at the UVLO pin drops below 0.25 V. When using a resistive divider at the voltage to be monitored, for example the supply voltage, any threshold for the monitored voltage can be programmed. If in undervoltage lockout mode, the device still maintains its supply voltage at VAUX, and it is not turned off until EN is programmed low. This undervoltage lockout function is implemented in order to prevent the malfunctioning of the converter.

10.3.1.7 Thermal Shutdown

The device has a built-in temperature sensor which monitors the internal IC temperature. If the temperature exceeds the programmed threshold (see electrical characteristics table), the device stops operating. As soon as the IC temperature has decreased below the programmed threshold, it starts operating again. There is a built-in hysteresis to avoid unstable operation at IC temperatures at the thermal shutdown threshold.

10.4 Device Functional Modes

10.4.1 Power Save Mode

The Power Save (PS) pin can be used to select different operation modes. To enable Power Save mode the PS pin must be set low. Power Save mode is used to improve efficiency at light load. If Power Save mode is enabled, the converter stops operating if the average inductor current decreases below about 300 mA and the output voltage is at or above its nominal value. If the output voltage decreases below its nominal value, the device ramps up the output voltage again by starting operation using a programmed average inductor current higher than required by the current load condition. Operation can last for one or several pulses. The converter stops operating once the conditions for stopping operation are met again.

The Power Save mode can be disabled by programming a high at the PS pin. In Down Conversion mode, Power Save mode is always enabled and the device cannot be forced into fixed frequency operation at light loads. The PS input supports standard logic thresholds.

10.4.2 Down Conversion Mode

If the input voltage reaches or exceeds the output voltage, the converter automatically changes to a Down Conversion mode. In this mode, the control circuit changes the behavior of the two rectifying switches. While continuing switching, it sets the voltage drop across the rectifying switches as high as needed to regulate the output voltage. This means the power losses in the converter increase. This must be taken into account for thermal consideration.

times greater than the current into the FB pin. The typical current into the FB pin is 0.01 μA , and the voltage across the resistor between FB and GND, R2, is typically 500 mV. Based on those two values, the recommended value for R2 should be lower than 500 k Ω , in order to set the divider current at 1 μA or higher. It is recommended to keep the value for this resistor in the range of 200 k Ω . The value of the resistor connected between VOUT and FB, R1, depending on the needed output voltage (V_{OUT}), can be calculated using [公式 1](#):

$$R1 = R2 \times \left(\frac{V_{\text{OUT}}}{V_{\text{FB}}} - 1 \right) \quad (1)$$

As an example, for an output voltage of 3.3 V, a 1-M Ω resistor should be chosen for R₁ when a 180-k Ω is selected for R₂.

11.2.2.2 Programming the UVLO Threshold Voltage

The UVLO input can be used to shut down the main output if the supply voltage is getting too low. The internal reference threshold is typically 250 mV. If the supply voltage should cause the shutdown when it is dropping below 250 mV, V_{IN} can be connected directly to the UVLO pin. If the shutdown should happen at higher voltages, a resistor divider can be used. R3 and R4 in [图 15](#) show an example of how to monitor the input voltage of the circuit. The current through the resistive divider should be about 100 times greater than the current into the UVLO pin. The typical current into the UVLO pin is 0.01 μA , and the voltage across R4 is equal to the UVLO voltage threshold that is generated on-chip, which has a value of 250 mV. Therefore, the recommended value for R4 is in the range of 250 k Ω . From this, the value of resistor R3, depending on the desired shutdown voltage V_{INMIN} , can be calculated using [公式 2](#).

$$R3 = R4 \times \left(\frac{V_{\text{INMIN}}}{V_{\text{UVLO}}} - 1 \right) \quad (2)$$

11.2.2.3 Inductor Selection

To make sure that the TPS6120X devices can operate, an inductor must be connected between the VIN and L pins. To estimate the minimum inductance value, [公式 3](#) can be used.

$$L_{\text{MIN}} = V_{\text{IN}} \times 0.5 \frac{\mu\text{S}}{\text{A}} \quad (3)$$

In [公式 3](#), the minimum inductance, L_{MIN} , for boost mode operation is calculated. V_{IN} is the maximum input voltage. The recommended inductor value range is between 1.5 μH and 4.7 μH . The minimum inductor value should not be below 1.5 μH , even if [公式 3](#) yields something lower. Using 2.2 μH is recommended anyway for getting best performance over the whole input and output voltage range.

With the chosen inductance value, the peak current for the inductor in steady state operation can be calculated using [公式 4](#).

$$I_{\text{LMAX}} = \frac{V_{\text{OUT}} \times I_{\text{OUT}}}{0.8 \times V_{\text{IN}}} + \frac{V_{\text{IN}} \times (V_{\text{OUT}} - V_{\text{IN}})}{2 \times V_{\text{OUT}} \times f \times L} \quad (4)$$

This would be the critical value for the current rating for selecting the inductor. It also needs to be taken into account that load transients and error conditions may cause higher inductor currents. The following inductor series from different suppliers have been used with TPS6120x converters:

表 3. List of Inductors

VENDOR	INDUCTOR SERIES
Coilcraft	LPS3015
	LPS4012
Murata	LQH3NP
Tajo Yuden	NR3015
Würth Elektronik	WE-TPC Typ S

11.2.2.4 Capacitor Selection

11.2.2.4.1 Input Capacitor

At least a 4.7- μ F input capacitor is recommended to improve transient behavior of the regulator and EMI behavior of the total power supply circuit. An X5R or X7R ceramic capacitor placed as close as possible to the VIN and PGND pins of the IC is recommended.

An R-C filter may be placed on the VIN pin to improve performance in applications with a noisy input source. A 100- Ω resistor and 0.1- μ F capacitor are recommended in this case. This filter is not required operation.

11.2.2.4.2 Output Capacitor

For the output capacitor, it is recommended to use small X5R or X7R ceramic capacitors placed as close as possible to the VOUT and PGND pins of the IC. If, for any reason, the application requires the use of large capacitors which can not be placed close to the IC, using a smaller ceramic capacitor in parallel to the large one is required. This small capacitor should be placed as close as possible to the VOUT and PGND pins of the IC.

To get an estimate of the recommended minimum output capacitance, [公式 5](#) can be used.

$$C_{OUT} = 5 \times L \times \frac{\mu F}{\mu H} \quad (5)$$

A capacitor with a value in the range of the calculated minimum should be used. This is required to maintain control loop stability. There are no additional requirements regarding minimum ESR. There is also no upper limit for the output capacitance value. Larger capacitors cause lower output voltage ripple as well as lower output voltage drops during load transients.

11.2.2.4.3 Capacitor at VAUX

Between the VAUX pin and GND pin, a capacitor must be connected. This capacitor is used to maintain and filter the control supply voltage, which is chosen from the highest of VIN, VOUT, and L. It is charged during startup and before the main output VOUT is turned on. To ensure stable operation, using at least 0.1 μ F is recommended. At output voltages below 2.5 V, the capacitance should be in the range of 1 μ F. Since this capacitor is also used as a snubber capacitor for the main switch, using a X5R or X7R ceramic capacitor with low ESR is important.

11.2.3 Application Curves

	FIGURE
Output Voltage TPS61201, Power Save Mode Disabled	图 16
Output Voltage TPS61202, Power Save Mode Disabled	图 17
Output Voltage TPS61201, Power Save Mode Enabled	图 18
Output Voltage TPS61202, Power Save Mode Enabled	图 19
TPS61201 Load Transient Response	图 20
TPS61202 Load Transient Response	图 21
TPS61201 Line Transient Response	图 22
TPS61202 Line Transient Response	图 23
TPS61201 Startup after Enable	图 24
TPS61202 Startup after Enable	图 25



图 16. Output Voltage, Power Save Mode Disabled



图 17. Output Voltage, Power Save Mode Disabled

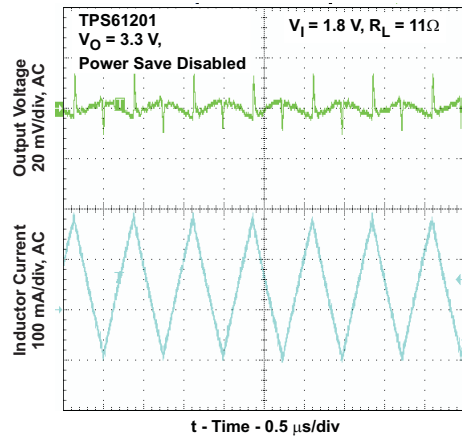

图 18. Output Voltage in Power Save Mode

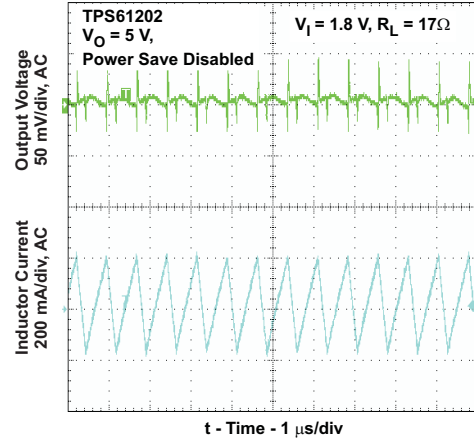

图 19. Output Voltage in Power Save Mode

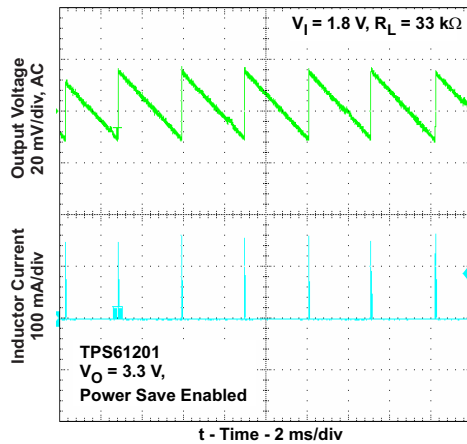

图 20. Load Transient Response

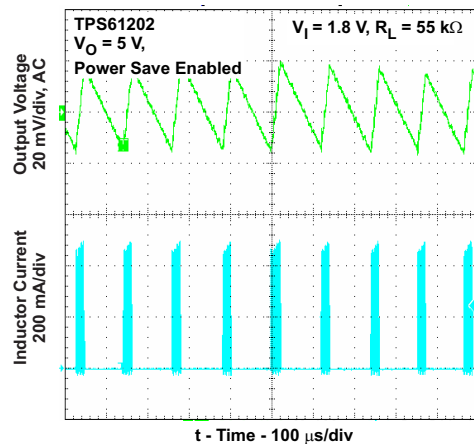

图 21. Load Transient Response

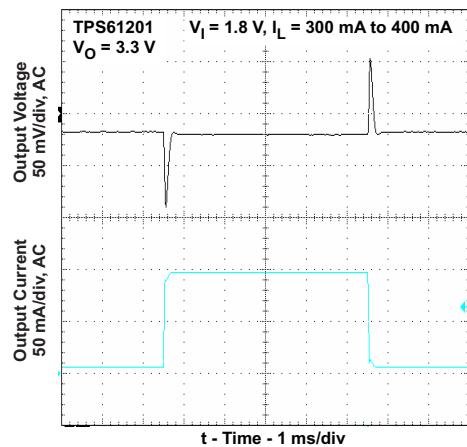

图 22. Line Transient Response

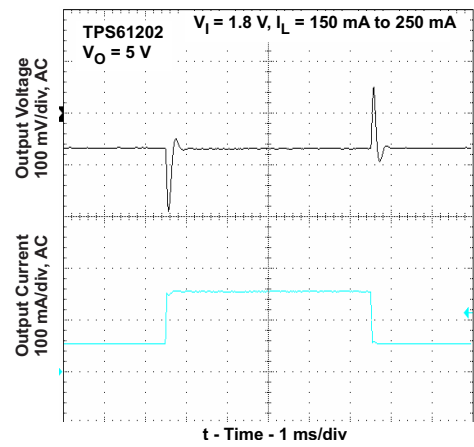

图 23. Line Transient Response

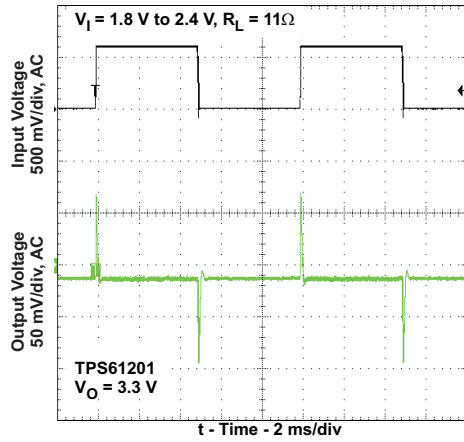

图 24. Start-Up After Enable

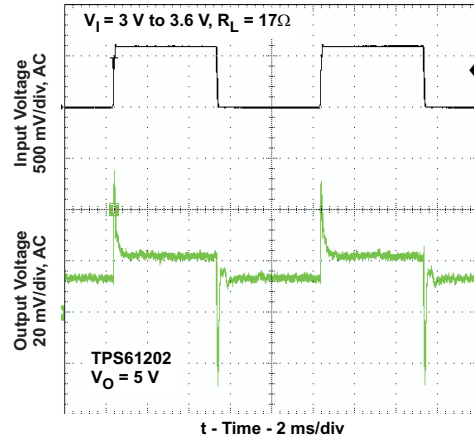

图 25. Start-Up After Enable

11.3 System Examples

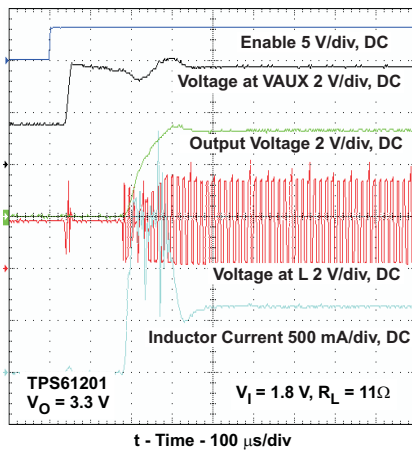

图 26. WLED Driver Circuit (See SLVA364)

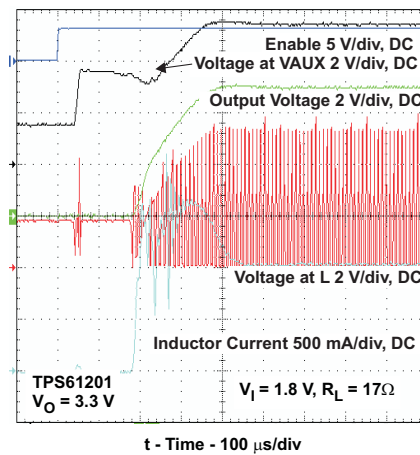

图 27. Solar Cell Circuit (See SLVA345)

System Examples (接下页)

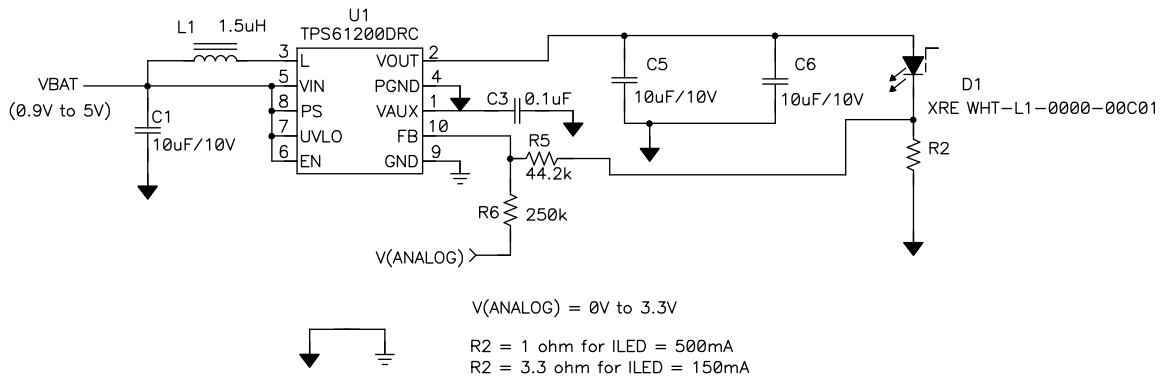
图 28. Reverse Battery Protection Circuit (See SLVA315)

12 Power Supply Recommendations

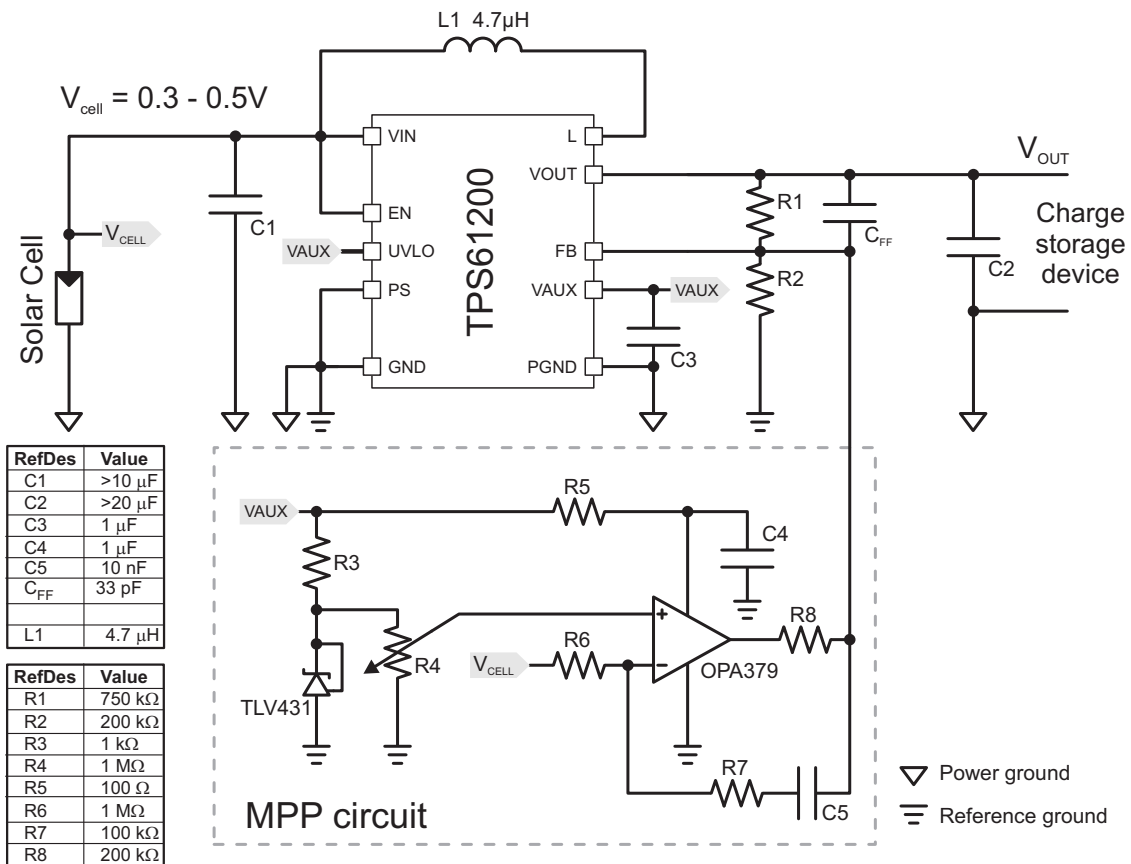
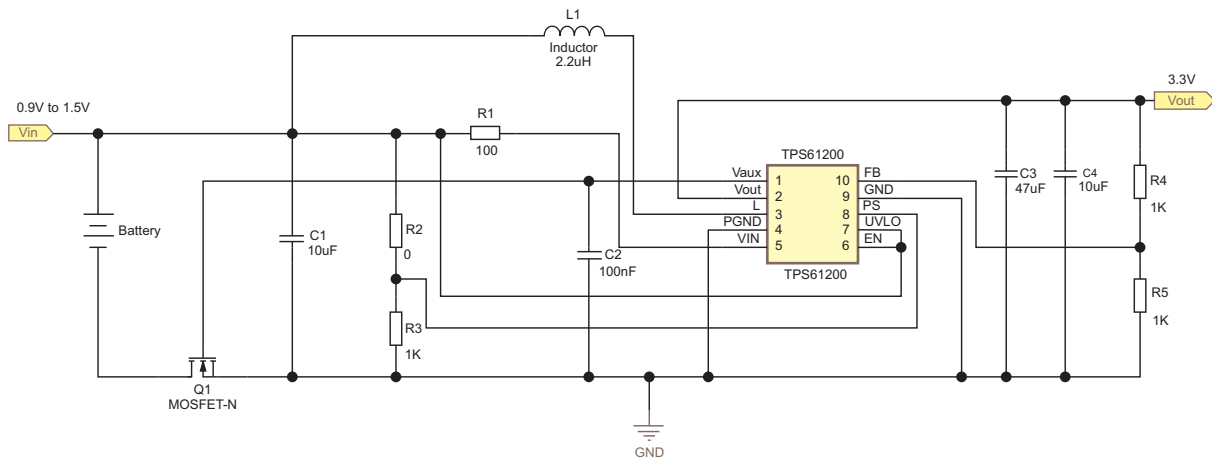
The power supply of TPS6120x DC-DC converters can be a single up to triple cell Alkaline, NiCd, NiMH battery with a typical terminal voltage between 0.7 V and 5.5 V. The TPS6120x can also be powered by one-cell Li-Ion or Li-Polymer with a typical voltage between 2.5 V and 4.2 V. Additionally, any other voltage source like solar cells or fuel cells with a typical output voltage between 0.3 V and 5.5 V can also be the power supply.

The input supply should be well regulated with the rating of TPS6120x. If the input supply is located more than a few inches from the device, additional bulk capacitance may be required in addition to the ceramic bypass capacitors. An electrolytic or tantalum capacitor with a value of 47 µF is a typical choice.

13 Layout

13.1 Layout Guidelines

As for all switching power supplies, the layout is an important step in the design, especially at high peak currents and high switching frequencies. If the layout is not carefully done, the regulator could show stability problems as well as EMI problems. Therefore, use wide and short traces for the main current path and for the power ground tracks. The input and output capacitor, as well as the inductor should be placed as close as possible to the IC. Use a common ground node for power ground and a different one for control ground to minimize the effects of ground noise. Connect these ground nodes at any place close to one of the ground pins of the IC.

The feedback divider should be placed as close as possible to the control ground pin of the IC. To lay out the control ground, it is recommended to use short traces as well, separated from the power ground traces. This avoids ground shift problems, which can occur due to superimposition of power ground current and control ground current. See [Figure 29](#) for the recommended layout.

13.2 Layout Example



图 29. EVM Layout

13.3 Thermal Considerations

Implementation of integrated circuits in low-profile and fine-pitch surface-mount packages typically requires special attention to power dissipation. Many system-dependent issues such as thermal coupling, airflow, added heat sinks and convection surfaces, and the presence of other heat-generating components affect the power-dissipation limits of a given component.

Three basic approaches for enhancing thermal performance are listed below.

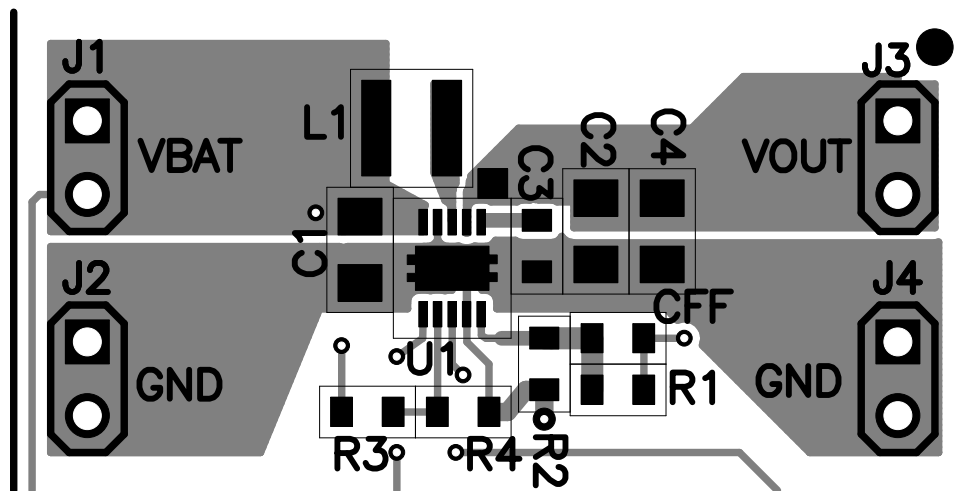
- Improving the power dissipation capability of the PCB design
- Improving the thermal coupling of the component to the PCB
- Introducing airflow in the system

The maximum recommended junction temperature (T_J) of the TPS6120x devices is 125°C. The thermal resistance of the 10-pin SON 3 × 3 package (DRC) is $R_{\theta JA} = 41.2 \text{ }^\circ\text{C/W}$, when the exposed thermal pad is soldered. Specified regulator operation is assured to a maximum ambient temperature, T_A , of 85°C. Therefore, the maximum power dissipation is about 971 mW. More power can be dissipated if the maximum ambient temperature of the application is lower.

$$P_{D(\text{MAX})} = \frac{T_{J(\text{MAX})} - T_A}{R_{\theta JA}} = \frac{125^\circ\text{C} - 85^\circ\text{C}}{41.2^\circ\text{C/W}} = 971\text{mW} \quad (6)$$

14 器件和文档支持

14.1 相关链接

下面的表格列出了快速访问链接。范围包括技术文档、支持和社区资源、工具和软件，以及样片或购买的快速访问。

表 4. 相关链接

器件	产品文件夹	样片与购买	技术文档	工具与软件	支持与社区
TPS61200	请单击此处	请单击此处	请单击此处	请单击此处	请单击此处
TPS61201	请单击此处	请单击此处	请单击此处	请单击此处	请单击此处
TPS61202	请单击此处	请单击此处	请单击此处	请单击此处	请单击此处

14.2 商标

All trademarks are the property of their respective owners.

14.3 静电放电警告



这些装置包含有限的内置 ESD 保护。存储或装卸时，应将导线一起截短或将装置放置于导电泡棉中，以防止 MOS 门极遭受静电损伤。

14.4 术语表

[SLYZ022](#) — TI 术语表。

这份术语表列出并解释术语、首字母缩略词和定义。

15 机械、封装和可订购信息

以下页中包括机械、封装和可订购信息。这些信息是针对指定器件可提供的最新数据。这些数据会在无通知且不对本文档进行修订的情况下发生改变。欲获得该数据表的浏览器版本，请查阅左侧的导航栏。

PACKAGING INFORMATION

Orderable Device	Status (1)	Package Type	Package Drawing	Pins	Package Qty	Eco Plan (2)	Lead finish/ Ball material (6)	MSL Peak Temp (3)	Op Temp (°C)	Device Marking (4/5)	Samples
TPS61200DRCR	ACTIVE	VSON	DRC	10	3000	RoHS & Green	NIPDAU	Level-2-260C-1 YEAR	-40 to 85	BRR	Samples
TPS61200DRCRG4	ACTIVE	VSON	DRC	10	3000	RoHS & Green	NIPDAU	Level-2-260C-1 YEAR	-40 to 85	BRR	Samples
TPS61200DRCT	ACTIVE	VSON	DRC	10	250	RoHS & Green	NIPDAU	Level-2-260C-1 YEAR	-40 to 85	BRR	Samples
TPS61201DRCR	ACTIVE	VSON	DRC	10	3000	RoHS & Green	NIPDAU	Level-2-260C-1 YEAR	-40 to 85	BRS	Samples
TPS61201DRCT	ACTIVE	VSON	DRC	10	250	RoHS & Green	NIPDAU	Level-2-260C-1 YEAR	-40 to 85	BRS	Samples
TPS61202DRCR	ACTIVE	VSON	DRC	10	3000	RoHS & Green	NIPDAU	Level-2-260C-1 YEAR	-40 to 85	BRT	Samples
TPS61202DRCT	ACTIVE	VSON	DRC	10	250	RoHS & Green	NIPDAU	Level-2-260C-1 YEAR	-40 to 85	BRT	Samples
TPS61202DSCR	ACTIVE	WSON	DSC	10	3000	RoHS & Green	NIPDAU	Level-2-260C-1 YEAR	-40 to 85	CER	Samples
TPS61202DSCT	ACTIVE	WSON	DSC	10	250	RoHS & Green	NIPDAU	Level-2-260C-1 YEAR	-40 to 85	CER	Samples
TPS61202DSCTG4	ACTIVE	WSON	DSC	10	250	RoHS & Green	NIPDAU	Level-2-260C-1 YEAR	-40 to 85	CER	Samples

(1) The marketing status values are defined as follows:

ACTIVE: Product device recommended for new designs.

LIFEBUY: TI has announced that the device will be discontinued, and a lifetime-buy period is in effect.

NRND: Not recommended for new designs. Device is in production to support existing customers, but TI does not recommend using this part in a new design.

PREVIEW: Device has been announced but is not in production. Samples may or may not be available.

OBSELETE: TI has discontinued the production of the device.

(2) **RoHS:** TI defines "RoHS" to mean semiconductor products that are compliant with the current EU RoHS requirements for all 10 RoHS substances, including the requirement that RoHS substance do not exceed 0.1% by weight in homogeneous materials. Where designed to be soldered at high temperatures, "RoHS" products are suitable for use in specified lead-free processes. TI may reference these types of products as "Pb-Free".

RoHS Exempt: TI defines "RoHS Exempt" to mean products that contain lead but are compliant with EU RoHS pursuant to a specific EU RoHS exemption.

Green: TI defines "Green" to mean the content of Chlorine (Cl) and Bromine (Br) based flame retardants meet JS709B low halogen requirements of <=1000ppm threshold. Antimony trioxide based flame retardants must also meet the <=1000ppm threshold requirement.

(3) MSL, Peak Temp. - The Moisture Sensitivity Level rating according to the JEDEC industry standard classifications, and peak solder temperature.

(4) There may be additional marking, which relates to the logo, the lot trace code information, or the environmental category on the device.

⁽⁵⁾ Multiple Device Markings will be inside parentheses. Only one Device Marking contained in parentheses and separated by a "~" will appear on a device. If a line is indented then it is a continuation of the previous line and the two combined represent the entire Device Marking for that device.

⁽⁶⁾ Lead finish/Ball material - Orderable Devices may have multiple material finish options. Finish options are separated by a vertical ruled line. Lead finish/Ball material values may wrap to two lines if the finish value exceeds the maximum column width.

Important Information and Disclaimer: The information provided on this page represents TI's knowledge and belief as of the date that it is provided. TI bases its knowledge and belief on information provided by third parties, and makes no representation or warranty as to the accuracy of such information. Efforts are underway to better integrate information from third parties. TI has taken and continues to take reasonable steps to provide representative and accurate information but may not have conducted destructive testing or chemical analysis on incoming materials and chemicals. TI and TI suppliers consider certain information to be proprietary, and thus CAS numbers and other limited information may not be available for release.

In no event shall TI's liability arising out of such information exceed the total purchase price of the TI part(s) at issue in this document sold by TI to Customer on an annual basis.

TAPE AND REEL INFORMATION



QUADRANT ASSIGNMENTS FOR PIN 1 ORIENTATION IN TAPE



*All dimensions are nominal

Device	Package Type	Package Drawing	Pins	SPQ	Reel Diameter (mm)	Reel Width W1 (mm)	A0 (mm)	B0 (mm)	K0 (mm)	P1 (mm)	W (mm)	Pin1 Quadrant
TPS61200DRCR	VSON	DRC	10	3000	330.0	12.4	3.3	3.3	1.1	8.0	12.0	Q2
TPS61200DRCR	VSON	DRC	10	3000	330.0	12.4	3.3	3.3	1.1	8.0	12.0	Q2
TPS61200DRCT	VSON	DRC	10	250	180.0	12.4	3.3	3.3	1.1	8.0	12.0	Q2
TPS61200DRCT	VSON	DRC	10	250	180.0	12.4	3.3	3.3	1.1	8.0	12.0	Q2
TPS61201DRCR	VSON	DRC	10	3000	330.0	12.4	3.3	3.3	1.1	8.0	12.0	Q2
TPS61201DRCR	VSON	DRC	10	3000	330.0	12.4	3.3	3.3	1.1	8.0	12.0	Q2
TPS61201DRCT	VSON	DRC	10	250	180.0	12.4	3.3	3.3	1.1	8.0	12.0	Q2
TPS61202DRCR	VSON	DRC	10	3000	330.0	12.4	3.3	3.3	1.1	8.0	12.0	Q2
TPS61202DRCR	VSON	DRC	10	3000	330.0	12.4	3.3	3.3	1.1	8.0	12.0	Q2
TPS61202DRCT	VSON	DRC	10	250	180.0	12.4	3.3	3.3	1.1	8.0	12.0	Q2
TPS61202DSCR	WSON	DSC	10	3000	330.0	12.4	3.3	3.3	1.1	8.0	12.0	Q2
TPS61202DSCT	WSON	DSC	10	250	180.0	12.4	3.3	3.3	1.1	8.0	12.0	Q2

TAPE AND REEL BOX DIMENSIONS

*All dimensions are nominal

Device	Package Type	Package Drawing	Pins	SPQ	Length (mm)	Width (mm)	Height (mm)
TPS61200DRCR	VSON	DRC	10	3000	853.0	449.0	35.0
TPS61200DRCR	VSON	DRC	10	3000	367.0	367.0	35.0
TPS61200DRCT	VSON	DRC	10	250	210.0	185.0	35.0
TPS61200DRCT	VSON	DRC	10	250	210.0	185.0	35.0
TPS61201DRCR	VSON	DRC	10	3000	367.0	367.0	35.0
TPS61201DRCR	VSON	DRC	10	3000	853.0	449.0	35.0
TPS61201DRCT	VSON	DRC	10	250	210.0	185.0	35.0
TPS61202DRCR	VSON	DRC	10	3000	853.0	449.0	35.0
TPS61202DRCR	VSON	DRC	10	3000	367.0	367.0	35.0
TPS61202DRCT	VSON	DRC	10	250	210.0	185.0	35.0
TPS61202DSCR	WSON	DSC	10	3000	853.0	449.0	35.0
TPS61202DSCT	WSON	DSC	10	250	210.0	185.0	35.0

GENERIC PACKAGE VIEW

DRC 10

VSON - 1 mm max height

3 x 3, 0.5 mm pitch

PLASTIC SMALL OUTLINE - NO LEAD

This image is a representation of the package family, actual package may vary.
Refer to the product data sheet for package details.

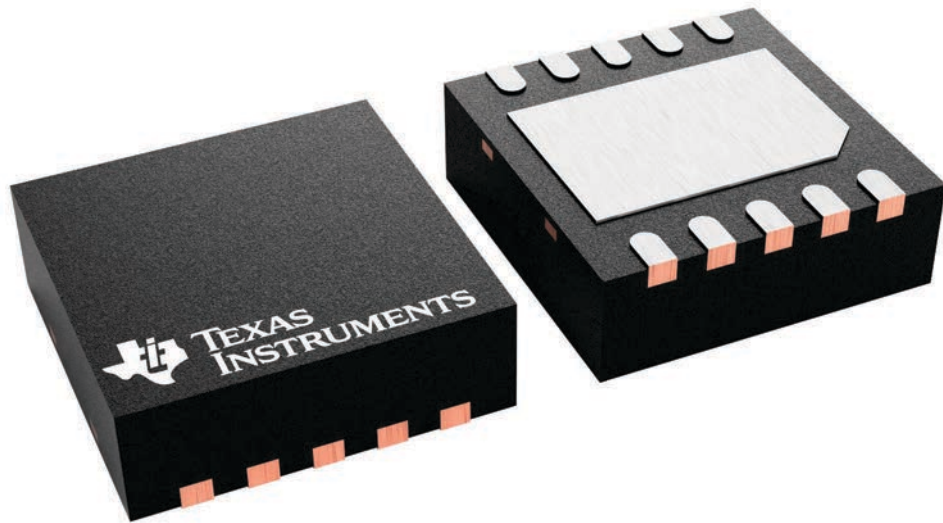

4226193/A

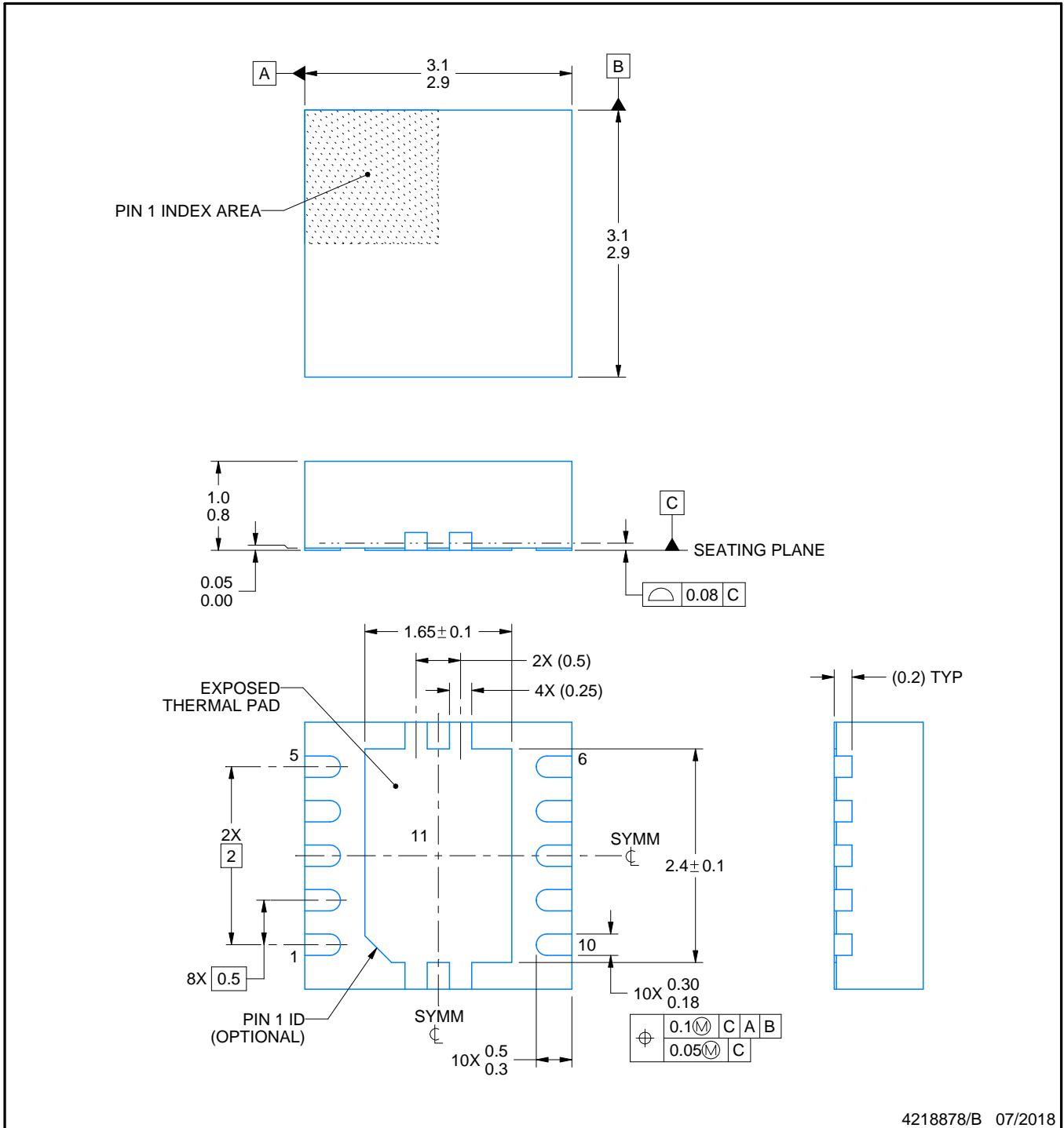

4218878/B 07/2018

NOTES:

1. All linear dimensions are in millimeters. Any dimensions in parenthesis are for reference only. Dimensioning and tolerancing per ASME Y14.5M.
2. This drawing is subject to change without notice.
3. The package thermal pad must be soldered to the printed circuit board for optimal thermal and mechanical performance.

EXAMPLE BOARD LAYOUT

DRC0010J

VSON - 1 mm max height

PLASTIC SMALL OUTLINE - NO LEAD



LAND PATTERN EXAMPLE
EXPOSED METAL SHOWN
SCALE:20X



SOLDER MASK DETAILS

4218878/B 07/2018

NOTES: (continued)

4. This package is designed to be soldered to a thermal pad on the board. For more information, see Texas Instruments literature number SLUA271 (www.ti.com/lit/sluea271).
5. Vias are optional depending on application, refer to device data sheet. If any vias are implemented, refer to their locations shown on this view. It is recommended that vias under paste be filled, plugged or tented.

GENERIC PACKAGE VIEW

DSC 10

WSON - 0.8 mm max height

PLASTIC SMALL OUTLINE - NO LEAD

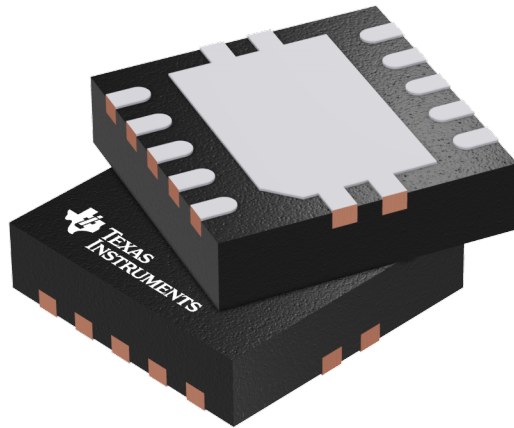

Images above are just a representation of the package family, actual package may vary.
Refer to the product data sheet for package details.

4207383/F

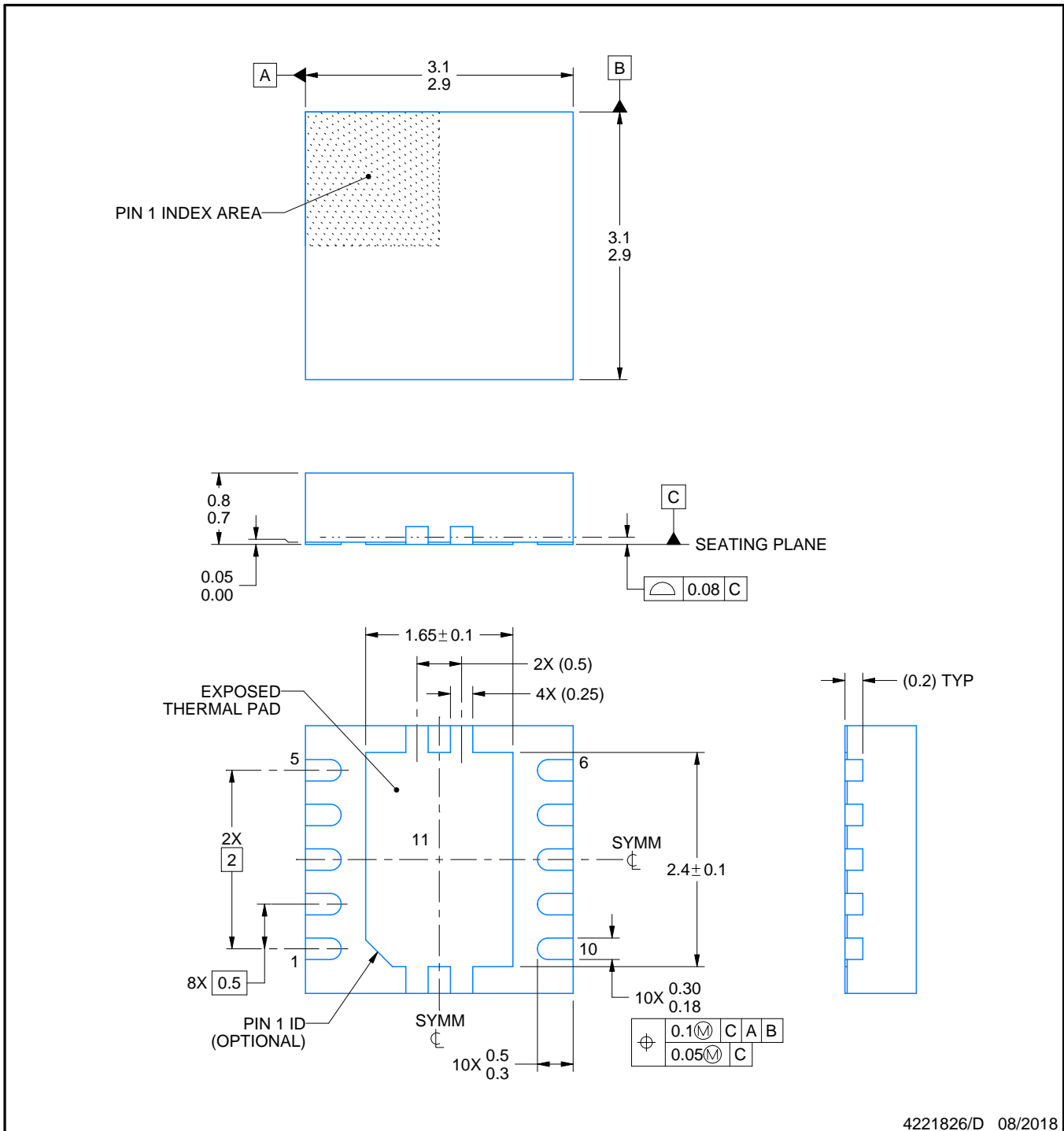
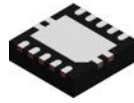

4221826/D 08/2018

NOTES:

1. All linear dimensions are in millimeters. Any dimensions in parenthesis are for reference only. Dimensioning and tolerancing per ASME Y14.5M.
2. This drawing is subject to change without notice.
3. The package thermal pad must be soldered to the printed circuit board for optimal thermal and mechanical performance.

EXAMPLE BOARD LAYOUT

DSC0010J

WSON - 0.8 mm max height

PLASTIC SMALL OUTLINE - NO LEAD

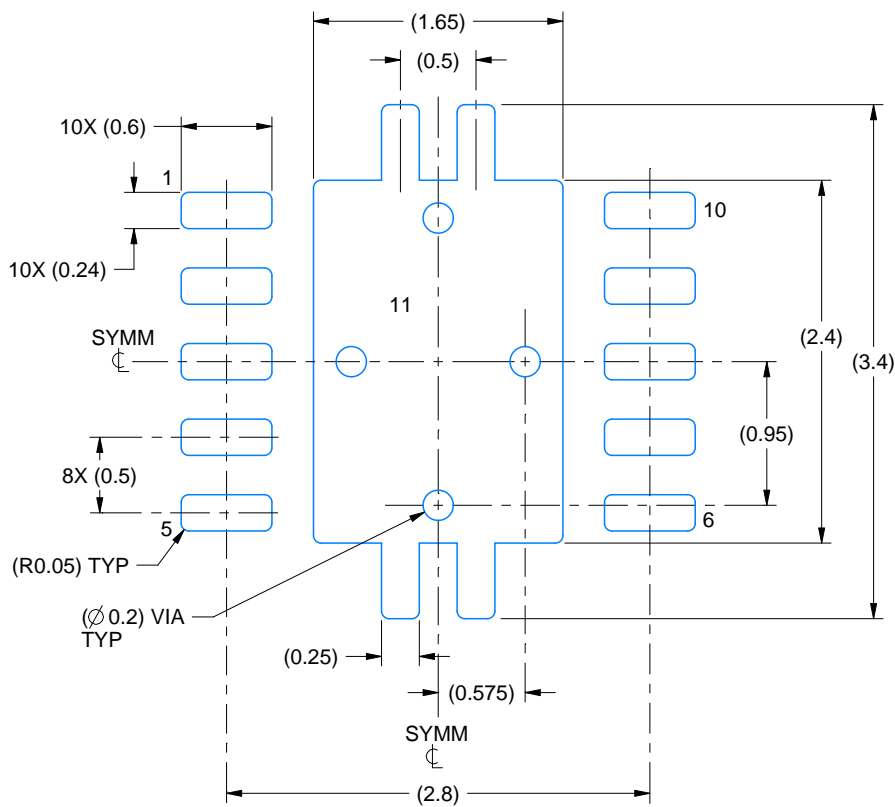

LAND PATTERN EXAMPLE
EXPOSED METAL SHOWN
SCALE:20X

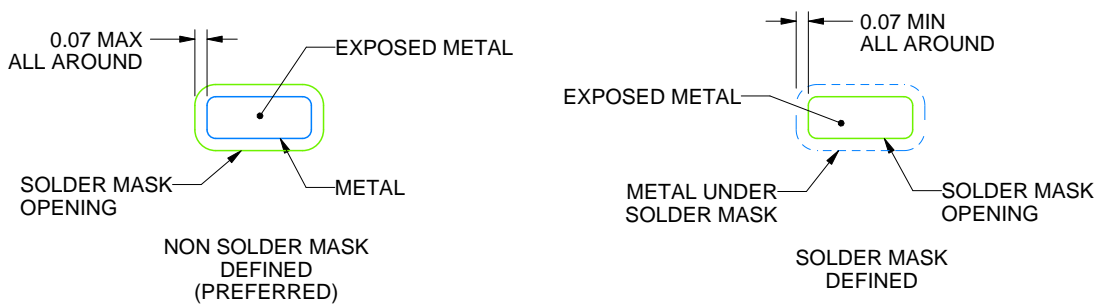

SOLDER MASK DETAILS

4221826/D 08/2018

NOTES: (continued)

4. This package is designed to be soldered to a thermal pad on the board. For more information, see Texas Instruments literature number SLUA271 (www.ti.com/lit/sluea271).
5. Vias are optional depending on application, refer to device data sheet. If any vias are implemented, refer to their locations shown on this view. It is recommended that vias under paste be filled, plugged or tented.

EXAMPLE STENCIL DESIGN

DSC0010J

WSON - 0.8 mm max height

PLASTIC SMALL OUTLINE - NO LEAD

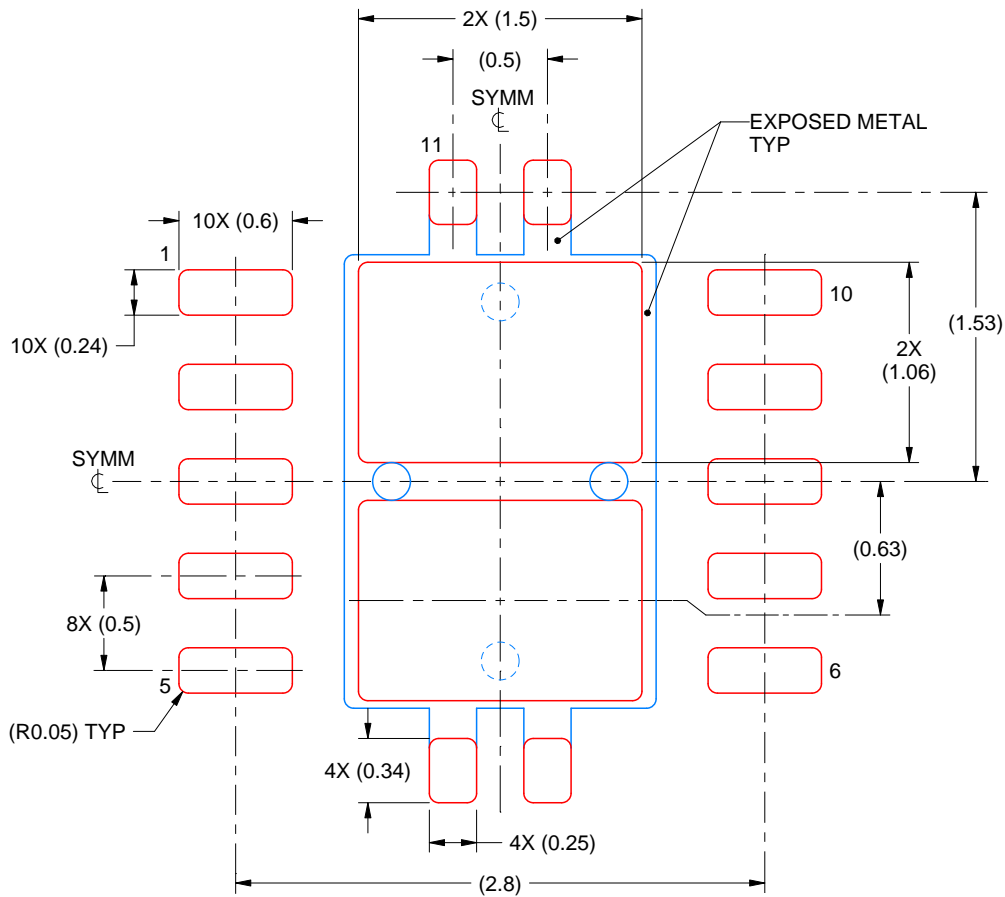

SOLDER PASTE EXAMPLE
BASED ON 0.125 mm THICK STENCIL

EXPOSED PAD 11:
80% PRINTED SOLDER COVERAGE BY AREA
SCALE:25X

4221826/D 08/2018

NOTES: (continued)

6. Laser cutting apertures with trapezoidal walls and rounded corners may offer better paste release. IPC-7525 may have alternate design recommendations.

重要声明和免责声明

TI 提供技术和可靠性数据（包括数据表）、设计资源（包括参考设计）、应用或其他设计建议、网络工具、安全信息和其他资源，不保证没有瑕疵且不做任何明示或暗示的担保，包括但不限于对适销性、某特定用途方面的适用性或不侵犯任何第三方知识产权的暗示担保。

这些资源可供使用 TI 产品进行设计的熟练开发人员使用。您将自行承担以下全部责任：(1) 针对您的应用选择合适的 TI 产品，(2) 设计、验证并测试您的应用，(3) 确保您的应用满足相应标准以及任何其他安全、安保或其他要求。这些资源如有变更，恕不另行通知。TI 授权您仅可将这些资源用于研发本资源所述的 TI 产品的应用。严禁对这些资源进行其他复制或展示。您无权使用任何其他 TI 知识产权或任何第三方知识产权。您应全额赔偿因在这些资源的使用中对 TI 及其代表造成的任何索赔、损害、成本、损失和债务，TI 对此概不负责。

TI 提供的产品受 TI 的销售条款 (<https://www.ti.com.cn/zh-cn/legal/termsofsale.html>) 或 [ti.com.cn](https://www.ti.com.cn) 上其他适用条款/TI 产品随附的其他适用条款的约束。TI 提供这些资源并不会扩展或以其他方式更改 TI 针对 TI 产品发布的适用的担保或担保免责声明。

邮寄地址：上海市浦东新区世纪大道 1568 号中建大厦 32 楼，邮政编码：200122
Copyright © 2021 德州仪器半导体技术（上海）有限公司