



## 24-BIT, 96/192-KHZ ASYNCHRONOUS STEREO AUDIO CODEC

### FEATURES

- 24-Bit Delta-Sigma ADC and DAC
- ADC, DAC Asynchronous Operation
- Stereo ADC:
  - High Performance: (Typical, 48 kHz)
    - THD+N: –93 dB
    - SNR: 99 dB
    - Dynamic Range: 99 dB
  - Sampling Rate: 16–96 kHz
  - System Clock: 256, 384, 512, 768  $f_s$
  - Full Scale Input: 3 V<sub>p-p</sub>
  - Antialiasing Filter Included
  - 1/64 Decimation Filter:
    - Pass-Band Ripple:  $\pm 0.05$  dB
    - Stop-Band Attenuation: –65 dB
  - On-Chip High-Pass Filter: 0.91 Hz at  $f_s = 48$  kHz
- Stereo DAC:
  - High Performance: (Typical, Differential, 48 kHz)
    - THD+N: –94 dB
    - SNR: 105 dB
    - Dynamic Range: 104 dB
  - Sampling Rate: 16–192 kHz
  - System Clock: 128, 192, 256, 384, 512, 768  $f_s$
  - Differential Voltage Output: 8 V<sub>p-p</sub>
  - Single-Ended Voltage Output: 4 V<sub>p-p</sub>
  - Analog Low-Pass Filter Included
  - 4 $\times$ /8 $\times$  Oversampling Digital Filter:
    - Pass-Band Ripple:  $\pm 0.04$  dB
    - Stop-Band Attenuation: –50 dB
  - Zero Flags
- Flexible Mode Control
  - 3-Wire SPI, 2-Wire I<sup>2</sup>C Compatible Serial Control Interface
  - Hardware Control Mode
- Multiple Functions via SPI or I<sup>2</sup>C Interface:
  - Digital Attenuation and Soft Mute for ADC

### and DAC

- Digital De-Emphasis: 32, 44.1, 48 kHz for DAC
- Power Down: ADC/DAC Independently
- Asynchronous/Synchronous Control for ADC/DAC Operation
- External Reset and Power-Down Pin:
  - ADC/DAC Simultaneously
- Audio Interface Mode:
  - ADC/DAC Independent Master/Slave
- Audio Data Format:
  - ADC/DAC Independent
  - I<sup>2</sup>S, Left-Justified, Right-Justified
- Dual Power Supplies:
  - 5-V for Analog and 3.3-V for Digital
- Package: TSSOP-28

### APPLICATIONS

- DVD-RW
- Digital TV
- Digital Set-Top Box
- Audio-Visual Applications

### DESCRIPTION

The PCM3060 is a low-cost, high-performance, single-chip, 24-bit stereo audio codec with single-ended analog inputs and differential analog outputs.

The stereo 24-bit ADC employs a 64-times delta-sigma modulator. It supports 16–96 kHz sampling rates and a 16/24-bit digital audio output word on the audio interface.

The stereo 24-bit DAC employs a 64- or 128-times delta-sigma modulator. It supports 16–192 kHz sampling rates and a 16/24-bit digital audio input word on the audio interface.

The PCM3060 supports fully independent operation of the sampling rate and audio interface for the ADC and DAC.

Each audio interface supports I<sup>2</sup>S, left-justified, and right-justified formats with 16/24-bit words.



Please be aware that an important notice concerning availability, standard warranty, and use in critical applications of Texas Instruments semiconductor products and disclaimers thereto appears at the end of this data sheet.



This integrated circuit can be damaged by ESD. Texas Instruments recommends that all integrated circuits be handled with appropriate precautions. Failure to observe proper handling and installation procedures can cause damage.

ESD damage can range from subtle performance degradation to complete device failure. Precision integrated circuits may be more susceptible to damage because very small parametric changes could cause the device not to meet its published specifications.

## DESCRIPTION (CONTINUED)

The PCM3060 can be software-controlled through a 3-wire SPI-compatible or 2-wire I<sup>2</sup>C-compatible serial interface, which provides access to all functions including digital attenuation, soft mute, de-emphasis etc.

The PCM3060 can be also used in hardware mode, which provides three basic functions.

The PCM3060 is fabricated using a highly advanced CMOS process and is available in a small 28-pin TSSOP package.

The PCM3060 is suitable for various sound processing applications for DVD-RW, digital TV, STB, and other AV equipment.

## ABSOLUTE MAXIMUM RATINGS

over operating free-air temperature range (unless otherwise noted) <sup>(1)</sup>

		VALUE	UNIT
Supply voltage	V <sub>CC</sub>	−0.3 to 6.5	V
	V <sub>DD</sub>	−0.3 to 4	
Ground voltage differences	AGND1, AGND2, DGND, SGND	±0.1	V
Digital input voltage	RST, MS, MC, MD, SCKI1, SCKI2, DIN	−0.3 to 6.5	V
	BCK1, BCK2, LRCK1, LRCK2, DOUT	−0.3 to (V <sub>DD</sub> + 0.3 V) < 4	V
	ZEROL, ZEROR, MODE	−0.3 to (V <sub>DD</sub> + 0.3 V) < 4	V
Analog input voltage	V <sub>INL</sub> , V <sub>INR</sub> , V <sub>COM</sub> , V <sub>OUTL+</sub> , V <sub>OUTL−</sub> , V <sub>OUTR+</sub> , V <sub>OUTR−</sub>	−0.3 to (V <sub>CC</sub> + 0.3 V) < 6.5	V
Input current (any pins except supplies)		±10	mA
T <sub>A</sub>	Ambient temperature under bias	−40 to 125	°C
T <sub>stg</sub>	Storage temperature	−55 to 150	°C
T <sub>J</sub>	Junction temperature	150	°C
Lead temperature (soldering)		260, 5 s	°C
Package temperature (IR reflow, peak)		260	°C

(1) Stresses beyond those listed under *absolute maximum ratings* may cause permanent damage to the device. These are stress ratings only and functional operation of the device at these or any other conditions beyond those indicated under *recommended operating conditions* is not implied. Exposure to absolute-maximum-rated conditions for extended periods may affect device reliability.

## RECOMMENDED OPERATING CONDITIONS

over operating free-air temperature range (unless otherwise noted)

		MIN	NOM	MAX	UNIT
V <sub>CC</sub>	Analog supply voltage	4.5	5	5.5	V
V <sub>DD</sub>	Digital supply voltage	2.7	3.3	3.6	V
Digital input interface level		TTL compatible			
Digital input clock frequency	Sampling frequency, LRCK1, LRCK2	16		96/192	kHz
	System clock frequency, SCKI1, SCKI2	2.048		36.864	MHz
Analog input level		3			V <sub>pp</sub>
Analog output load resistance	AC-coupled	5			kΩ
	DC-coupled	10			kΩ
Analog output load capacitance		50			pF
Digital output load capacitance		20			pF
Operating free-air temperature		−25	25	85	°C

## ELECTRICAL CHARACTERISTICS

All specifications at  $T_A = 25^\circ\text{C}$ ,  $V_{CC} = 5\text{ V}$ ,  $V_{DD} = 3.3\text{ V}$ ,  $f_S = 48\text{ kHz}$ ,  $\text{SCKI1} = \text{SCKI2} = 512\text{ f}_S$ , 24-bit data (unless otherwise noted).

PARAMETER	TEST CONDITIONS	PCM3060PW			UNIT		
		MIN	TYP	MAX			
<b>DIGITAL INPUT/OUTPUT</b>							
<b>DATA FORMAT</b>							
Audio data interface format		I <sup>2</sup> S, LJ, RJ					
Audio data word length		16, 24			Bits		
Audio data format		MSB-first, 2s-complement					
f <sub>S</sub>	Sampling frequency, ADC	16	48	96	kHz		
	Sampling frequency, DAC	16	48	192			
	System clock frequency	128, 192, 256, 384, 512, 768 f <sub>S</sub>		2.048	36.864	MHz	
<b>INPUT LOGIC</b>							
V <sub>IH</sub> <sup>(1)</sup>	Input logic level		2		V <sub>DD</sub>	VDC	
V <sub>IL</sub> <sup>(1)</sup>					0.8		
V <sub>IH</sub> <sup>(2) (3)</sup>			2				5.5
V <sub>IL</sub> <sup>(2) (3)</sup>							0.8
I <sub>IH</sub> <sup>(2)</sup>	Input logic current	V <sub>IN</sub> = V <sub>DD</sub>				±10	
I <sub>IL</sub> <sup>(2)</sup>		V <sub>IN</sub> = 0 V				±10	
I <sub>IH</sub> <sup>(1) (3)</sup>		V <sub>IN</sub> = V <sub>DD</sub>		65		100	
I <sub>IL</sub> <sup>(1) (3)</sup>		V <sub>IN</sub> = 0 V				±10	
<b>OUTPUT LOGIC</b>							
V <sub>OH</sub> <sup>(4)</sup>	Output logic level	I <sub>OUT</sub> = -4 mA	2.8			VDC	
V <sub>OL</sub> <sup>(4) (5)</sup>		I <sub>OUT</sub> = 4 mA			0.5		
<b>REFERENCE OUTPUT</b>							
V <sub>COM</sub> output voltage		0.5 V <sub>CC</sub>				V	
V <sub>COM</sub> output impedance		7	12.5	18		kΩ	
Allowable V <sub>COM</sub> output source/sink current					±1	μA	
<b>ADC CHARACTERISTICS</b>							
Resolution		16	24			Bits	
<b>ANALOG INPUT</b>							
Full scale input voltage	V <sub>INL</sub> , V <sub>INR</sub> = 0 dB	0.6 V <sub>CC</sub>				Vp-p	
Center voltage		0.5 V <sub>CC</sub>				V	
Input impedance		10				kΩ	
Antialiasing filter response	-3 dB	300				kHz	
<b>DC ACCURACY</b>							
Gain mismatch, channel-to-channel	Full-scale input, V <sub>INL</sub> , V <sub>INR</sub>		±2	±8		% of FSR	
Gain error	Full-scale input, V <sub>INL</sub> , V <sub>INR</sub>		±2	±8		% of FSR	
Bipolar zero error	HPF bypass, V <sub>INL</sub> , V <sub>INR</sub>		±0.5	±2		% of FSR	

- (1) BCK1, BCK2, LRCK1, LRCK2 (in slave mode, Schmitt-trigger input with 50-kΩ typical internal pulldown resistor)  
 (2) SCKI1, SCKI2, DIN,  $\overline{\text{MS}}/\text{ADR}/\text{IFMD}$ , MC/SCL/FMT, MD/SDA/IFMD (Schmitt-trigger input, 5-V tolerant).  
 (3)  $\overline{\text{RST}}$  (Schmitt-trigger input with 50-kΩ typical internal pulldown resistor, 5-V tolerant).  
 (4) BCK1, BCK2, LRCK1, LRCK2 (in master mode), DOUT, ZEROL, ZEROR  
 (5) MD/SDA/IFMD (in I<sup>2</sup>C mode, open drain LOW output)

**ELECTRICAL CHARACTERISTICS (continued)**

All specifications at  $T_A = 25^\circ\text{C}$ ,  $V_{CC} = 5\text{ V}$ ,  $V_{DD} = 3.3\text{ V}$ ,  $f_S = 48\text{ kHz}$ ,  $\text{SCK11} = \text{SCK12} = 512 f_S$ , 24-bit data (unless otherwise noted).

PARAMETER	TEST CONDITIONS	PCM3060PW			UNIT
		MIN	TYP	MAX	
<b>DYNAMIC PERFORMANCE</b> <sup>(6)</sup> <sup>(7)</sup>					
THD+N	Total harmonic distortion + noise	$V_{IN} = -1\text{ dB}$ , $f_S = 48\text{ kHz}$	-93	-85	dB
		$V_{IN} = -1\text{ dB}$ , $f_S = 96\text{ kHz}$	-93		
Dynamic range		$f_S = 48\text{ kHz}$ , A-weighted	95	99	dB
		$f_S = 96\text{ kHz}$ , A-weighted		101	
SNR	Signal-to-noise ratio	$f_S = 48\text{ kHz}$ , A-weighted	95	99	dB
		$f_S = 96\text{ kHz}$ , A-weighted		101	
Channel separation (between L-ch and R-ch)		$f_S = 48\text{ kHz}$	92	96	dB
		$f_S = 96\text{ kHz}$		98	
Crosstalk from DAC		$f_{S1} = 48\text{ kHz}$ , $f_{S2} = 44.1\text{ kHz}$	92	96	dB
		$f_{S1} = 96\text{ kHz}$ , $f_{S2} = 44.1\text{ kHz}$		98	
<b>DIGITAL FILTER PERFORMANCE</b>					
Pass band				$0.454 f_S$	Hz
Stop band			$0.583 f_S$		Hz
Pass-band ripple	$< 0.454 f_S$			$\pm 0.05$	dB
Stop-band attenuation	$> 0.583 f_S$		-65		dB
Group delay time				$17.4/f_S$	s
HPF frequency response	-3 dB			$0.019 f_S / 1000$	Hz
<b>DAC CHARACTERISTICS</b>					
Resolution		16	24		Bits
<b>ANALOG OUTPUT</b>					
Output voltage	Single-ended		$0.8 V_{CC}$		Vp-p
	Differential		$1.6 V_{CC}$		
Center voltage	Single-ended		$0.5 V_{CC}$		V
	Differential		$0.48 V_{CC}$		
Load impedance	AC-coupled		5		k $\Omega$
	DC-coupled		10		
LPF frequency response	$f = 20\text{ kHz}$		-0.02		dB
	$f = 44\text{ kHz}$		-0.07		
	-3 dB			300	kHz
<b>DC ACCURACY</b>					
Gain mismatch, channel-to-channel			$\pm 1$	$\pm 4$	% of FSR
Gain error			$\pm 2$	$\pm 6$	% of FSR
Bipolar zero error	Single-ended		$\pm 1$	$\pm 2$	% of FSR
	Differential ( $V_{OUTX+} - V_{OUTX-}$ )		$\pm 1$		

(6)  $f_{IN} = 1\text{ kHz}$ , using System Two audio measurement system by Audio Precision, RMS mode with 20-kHz LPF and 400-Hz HPF.

(7)  $f_S = 96\text{ kHz}$ :  $\text{SCK11} = \text{SCK12} = 256 f_S$ ,  $f_S = 192\text{ kHz}$ :  $\text{SCK11} = 512 f_S$  at  $f_S = 48\text{ kHz}$  and  $\text{SCK12} = 128 f_S$  at  $f_S = 192\text{ kHz}$ .

**ELECTRICAL CHARACTERISTICS (continued)**

 All specifications at  $T_A = 25^\circ\text{C}$ ,  $V_{CC} = 5\text{ V}$ ,  $V_{DD} = 3.3\text{ V}$ ,  $f_S = 48\text{ kHz}$ ,  $\text{SCKI1} = \text{SCKI2} = 512 f_S$ , 24-bit data (unless otherwise noted).

PARAMETER	TEST CONDITIONS	PCM3060PW			UNIT
		MIN	TYP	MAX	
<b>DYNAMIC PERFORMANCE (SINGLE-ENDED)</b> <sup>(8)</sup> <sup>(9)</sup> <sup>(10)</sup>					
THD+N	Total harmonic distortion + noise	$V_{OUT} = 0\text{ dB}$ , $f_S = 48\text{ kHz}$	–93	–85	dB
		$V_{OUT} = 0\text{ dB}$ , $f_S = 96\text{ kHz}$	–94		
		$V_{OUT} = 0\text{ dB}$ , $f_S = 192\text{ kHz}$	–94		
Dynamic range		$f_S = 48\text{ kHz}$ , EIAJ, A-weighted	99	103	dB
		$f_S = 96\text{ kHz}$ , EIAJ, A-weighted		103	
		$f_S = 192\text{ kHz}$ , EIAJ, A-weighted		103	
SNR	Signal-to-noise ratio	$f_S = 48\text{ kHz}$ , EIAJ, A-weighted	100	104	dB
		$f_S = 96\text{ kHz}$ , EIAJ, A-weighted		104	
		$f_S = 192\text{ kHz}$ , EIAJ, A-weighted		104	
Channel separation		$f_S = 48\text{ kHz}$	97	101	dB
		$f_S = 96\text{ kHz}$		101	
		$f_S = 192\text{ kHz}$		101	
Crosstalk from ADC		$f_{S1} = 48\text{ kHz}$ , $f_{S2} = 44.1\text{ kHz}$	97	101	dB
		$f_{S1} = 48\text{ kHz}$ , $f_{S2} = 88.2\text{ kHz}$		101	
		$f_{S1} = 48\text{ kHz}$ , $f_{S2} = 176.4\text{ kHz}$		101	
<b>DYNAMIC PERFORMANCE (DIFFERENTIAL)</b> <sup>(8)</sup> <sup>(9)</sup> <sup>(11)</sup>					
THD+N	Total harmonic distortion + noise	$V_{OUT} = 0\text{ dB}$ , $f_S = 48\text{ kHz}$		–94	dB
		$V_{OUT} = 0\text{ dB}$ , $f_S = 96\text{ kHz}$		–95	
		$V_{OUT} = 0\text{ dB}$ , $f_S = 192\text{ kHz}$		–95	
Dynamic range		$f_S = 48\text{ kHz}$ , EIAJ, A-weighted		104	dB
		$f_S = 96\text{ kHz}$ , EIAJ, A-weighted		104	
		$f_S = 192\text{ kHz}$ , EIAJ, A-weighted		104	
SNR	Signal-to-noise ratio	$f_S = 48\text{ kHz}$ , EIAJ, A-weighted		105	dB
		$f_S = 96\text{ kHz}$ , EIAJ, A-weighted		105	
		$f_S = 192\text{ kHz}$ , EIAJ, A-weighted		105	
Channel separation		$f_S = 48\text{ kHz}$		103	dB
		$f_S = 96\text{ kHz}$		103	
		$f_S = 192\text{ kHz}$		103	
Crosstalk from ADC		$f_{S1} = 48\text{ kHz}$ , $f_{S2} = 44.1\text{ kHz}$		103	dB
		$f_{S1} = 48\text{ kHz}$ , $f_{S2} = 88.2\text{ kHz}$		103	
		$f_{S1} = 48\text{ kHz}$ , $f_{S2} = 176.4\text{ kHz}$		103	
<b>DIGITAL FILTER PERFORMANCE</b> <b>SHARP ROLLOFF</b>					
Pass band				$0.454 f_S$	Hz
Stop band			$0.546 f_S$		Hz
Pass-band ripple	$< 0.454 f_S$			$\pm 0.04$	dB
Stop-band attenuation	$> 0.546 f_S$		–50		dB

 (8)  $f_S = 96\text{ kHz}$ :  $\text{SCKI1} = \text{SCKI2} = 256 f_S$ ,  $f_S = 192\text{ kHz}$ :  $\text{SCKI1} = 512 f_S$  at  $f_S = 48\text{ kHz}$  and  $\text{SCKI2} = 128 f_S$  at  $f_S = 192\text{ kHz}$ .

 (9)  $f_{OUT} = 1\text{ kHz}$ , using System Two audio measurement system by Audio Precision, RMS mode with 20-kHz LPF and 400-Hz HPF.

 (10) Assumed 5-k $\Omega$  AC-coupled second-order LPF and 115-dB or higher- performance buffer.

 (11) Assumed 10-k $\Omega$  DC-coupled second-order LPF and 115- dB or higher-performance differential to single-ended converter.

**ELECTRICAL CHARACTERISTICS (continued)**

All specifications at  $T_A = 25^\circ\text{C}$ ,  $V_{CC} = 5\text{ V}$ ,  $V_{DD} = 3.3\text{ V}$ ,  $f_S = 48\text{ kHz}$ ,  $\text{SCK11} = \text{SCK12} = 512 f_S$ , 24-bit data (unless otherwise noted).

PARAMETER		TEST CONDITIONS	PCM3060PW			UNIT
			MIN	TYP	MAX	
<b>DIGITAL FILTER PERFORMANCE</b>		<b>SLOW ROLLOFF</b>				
	Pass band				0.308 $f_S$	Hz
	Stop band		0.73 $f_S$			Hz
	Pass-band ripple	< 0.308 $f_S$			$\pm 0.5$	dB
	Stop-band attenuation	> 0.73 $f_S$	-35			dB
<b>DIGITAL FILTER PERFORMANCE</b>						
	Group delay time				20/ $f_S$	s
	De-emphasis error				$\pm 0.1$	dB
<b>POWER SUPPLY REQUIREMENTS</b>						
$V_{CC}$	Voltage range		4.5	5	5.5	VDC
$V_{DD}$			2.7	3.3	3.6	
$I_{CC}$	Supply current	$f_S = 48\text{ kHz/ADC}$ , $f_S = 48\text{ kHz/DAC}$		25	36	mA
		$f_S = 96\text{ kHz/ADC}$ , $f_S = 96\text{ kHz/DAC}$		25		mA
		$f_{S1} = 48\text{ kHz/ADC}$ , $f_{S2} = 192\text{ kHz/DAC}$		25		mA
		$f_S = 48\text{ kHz/ADC}$ , power down/DAC		12		mA
		Power down/ADC, $f_S = 48\text{ kHz/DAC}$		13		mA
		Full power down <sup>(12)</sup> <sup>(13)</sup>		780		$\mu\text{A}$
$I_{DD}$	Supply current	$f_S = 48\text{ kHz/ADC}$ , $f_S = 48\text{ kHz/DAC}$		9	12	mA
		$f_S = 96\text{ kHz/ADC}$ , $f_S = 96\text{ kHz/DAC}$		16		mA
		$f_{S1} = 48\text{ kHz/ADC}$ , $f_{S2} = 192\text{ kHz/DAC}$		13		mA
		$f_S = 48\text{ kHz/ADC}$ , power down/DAC		5		mA
		Power down/ADC, $f_S = 48\text{ kHz/DAC}$		5		mA
		Full power down <sup>(12)</sup>		150		$\mu\text{A}$
Power dissipation		$f_S = 48\text{ kHz/ADC}$ , $f_S = 48\text{ kHz/DAC}$		160	220	mW
		$f_S = 96\text{ kHz/ADC}$ , $f_S = 96\text{ kHz/DAC}$		180		
		$f_{S1} = 48\text{ kHz/ADC}$ , $f_{S2} = 192\text{ kHz/DAC}$		170		
		$f_S = 48\text{ kHz/ADC}$ , power down/DAC		77		
		Power down/ADC, $f_S = 48\text{ kHz/DAC}$		82		
		Full power down <sup>(12)</sup> <sup>(13)</sup>		4.4		
<b>TEMPERATURE RANGE</b>						
	Operation temperature		-25		85	$^\circ\text{C}$
$\theta_{JA}$	Thermal resistance			105		$^\circ\text{C/W}$

(12) Halt SCK11, SCK12, BCK1, BCK2, LRCK1, LRCK2

(13) AC-coupled configuration. If DC-coupled configuration is used, DC current flow to external load is added and it depends on external load resistance.

**PIN ASSIGNMENTS**

**PCM3060**  
**PW (TSSOP) PACKAGE**  
**(TOP VIEW)**

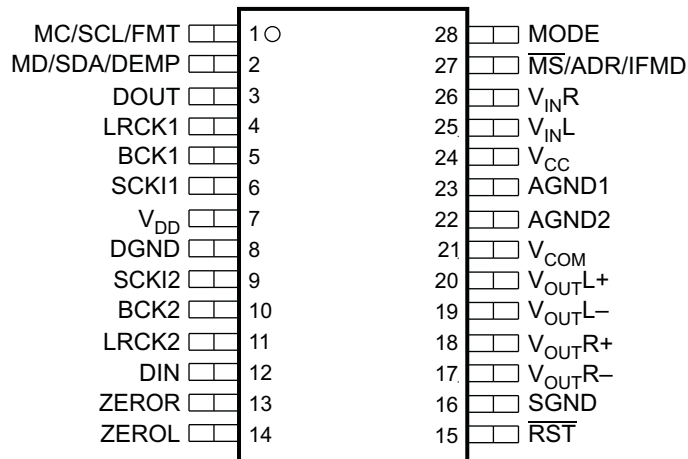

P0043-03

**Table 1. TERMINAL FUNCTIONS**

TERMINAL		I/O	DESCRIPTION
NAME	PIN		
AGND1	23	–	ADC analog ground
AGND2	22	–	DAC analog ground
BCK1	5	I/O <sup>(1)</sup>	Audio data bit clock input/output for ADC
BCK2	10	I/O <sup>(1)</sup>	Audio data bit clock input/output for DAC
DGND	8	–	Digital ground
DIN	12	I <sup>(2)</sup>	Audio data digital input for DAC
DOUT	3	O	Audio data digital output for ADC
LRCK1	4	I/O <sup>(1)</sup>	Audio data left/right clock input/output for ADC
LRCK2	11	I/O <sup>(1)</sup>	Audio data left/right clock input/output for DAC
MC/SCL/FMT	1	I <sup>(2)</sup>	Mode control, clock for SPI, clock for I <sup>2</sup> C, format for H/W mode <sup>(5)</sup>
MD/SDA/DEMP	2	I/O <sup>(3)</sup>	Mode control, data for SPI, data for I <sup>2</sup> C, de-emphasis for H/W mode
MODE	28	I <sup>(4)</sup>	This pin provides four operation modes according to its input connection. Connected directly to V <sub>DD</sub> : SPI mode. Connected to V <sub>DD</sub> through 220-k $\Omega$ pullup resistor: H/W mode, single-ended V <sub>OUTX</sub> . Connected to DGND through 220-k $\Omega$ pulldown resistor: H/W mode, differential V <sub>OUTX</sub> . Connected directly to DGND : I <sup>2</sup> C mode.
$\overline{MS}$ /ADR/IFMD	27	I <sup>(2)</sup>	Mode control, select for SPI with low active, address for I <sup>2</sup> C, I/F mode for H/W mode
RST	15	I <sup>(5)</sup>	Reset and power-down control input, active-low
SCK1	6	I <sup>(2)</sup>	System clock input for ADC
SCK2	9	I <sup>(2)</sup>	System clock input for DAC
SGND	16	–	Shield analog ground
V <sub>CC</sub>	24	–	ADC, DAC analog power supply, 5-V
V <sub>COM</sub>	21	–	ADC, DAC voltage common decoupling
V <sub>DD</sub>	7	–	Digital power supply, 3.3-V
V <sub>INL</sub>	25	I	Analog input to ADC, L-channel
V <sub>INR</sub>	26	I	Analog input to ADC, R-channel
V <sub>OUTL</sub> –	19	O	Analog output from DAC, L-channel – in differential mode, must be open in single-ended mode
V <sub>OUTL</sub> +	20	O	Analog output from DAC, L-channel + in differential mode, L-channel in single-ended mode
ZEROL	14	O	Zero flag, L-channel
ZEROR	13	O	Zero flag, R-channel
V <sub>OUTR</sub> –	17	O	Analog output from DAC, R-channel – in differential mode, must be open in single-ended mode
V <sub>OUTR</sub> +	18	O	Analog output from DAC, R-channel + in differential mode, R-channel in single-ended mode

(1) Schmitt-trigger input/output with 50-k $\Omega$  typical internal pulldown resistor

(2) Schmitt-trigger input, 5-V tolerant

(3) Schmitt-trigger input, 5 V tolerant for SPI, H/W mode and Schmitt-trigger input/open drain LOW output, 5-V tolerant for I<sup>2</sup>C

(4) V<sub>DD</sub>/2 biased, quad-state input

(5) Schmitt-trigger input with 50-k $\Omega$  typical internal pulldown resistor, 5-V tolerant

**BLOCK DIAGRAM**

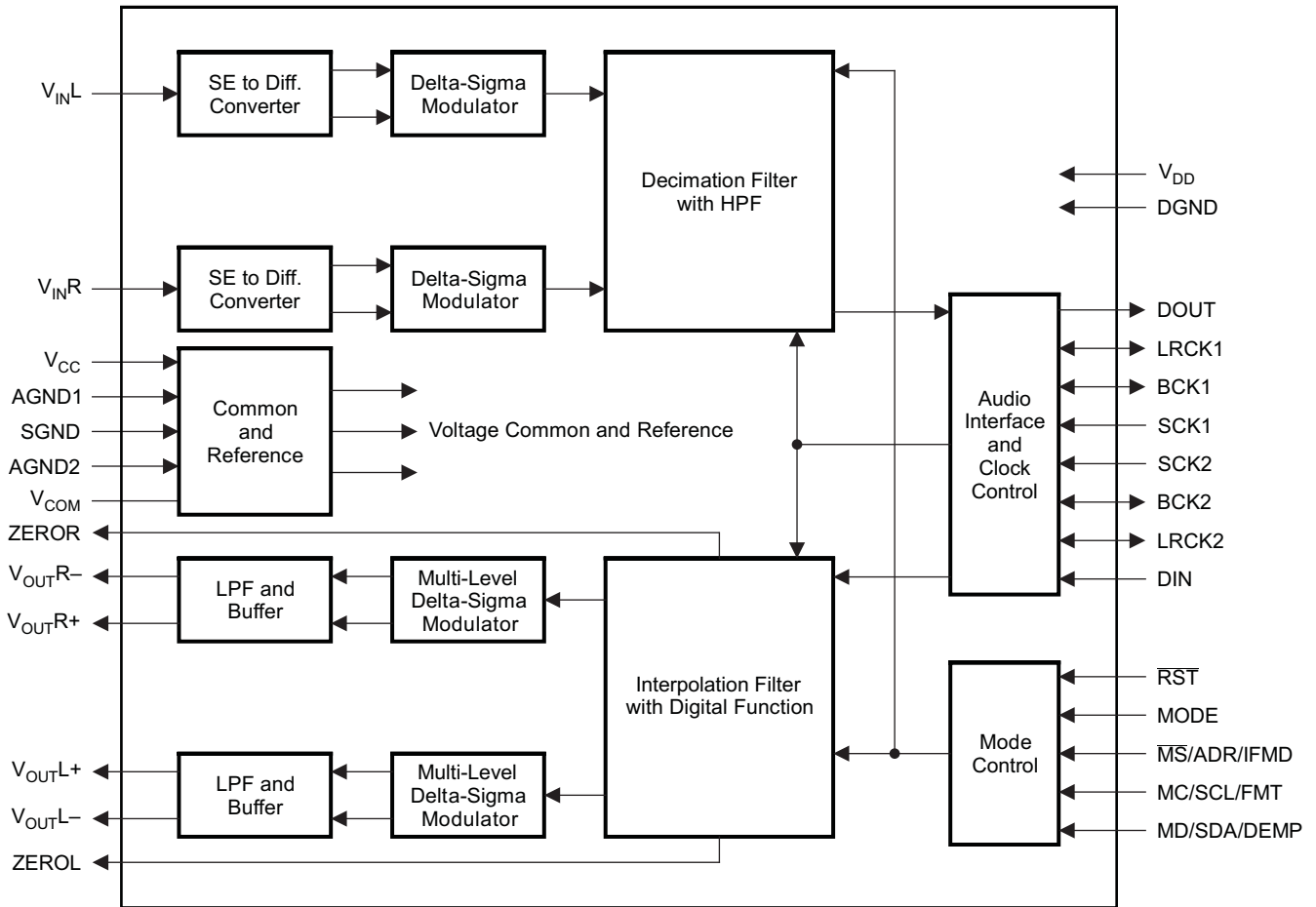

B0229-01

### TYPICAL PERFORMANCE CURVES OF ADC INTERNAL FILTER

All specifications at  $T_A = 25^\circ\text{C}$ ,  $V_{CC} = 5\text{ V}$ ,  $V_{DD} = 3.3\text{ V}$ ,  $f_S = 48\text{ kHz}$ ,  $\text{SCK11} = \text{SCK12} = 512 f_S$ , 24-bit data, unless otherwise noted.

#### DIGITAL FILTER

DECIMATION FILTER, STOP-BAND CHARACTERISTICS

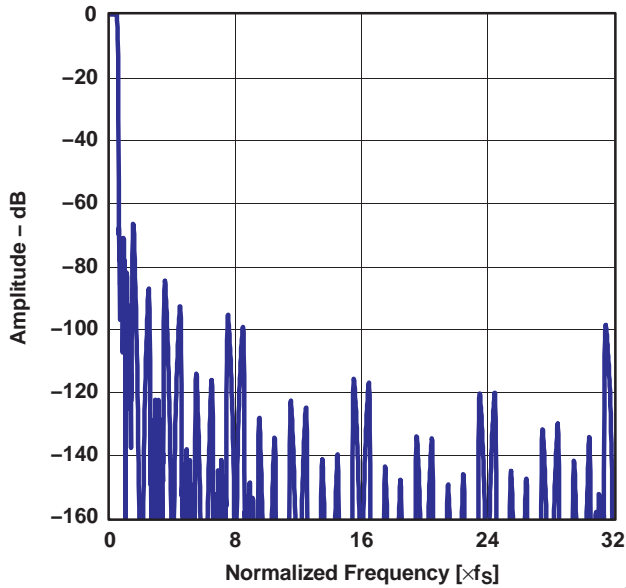

Figure 1.

DECIMATION FILTER, PASS-BAND CHARACTERISTICS

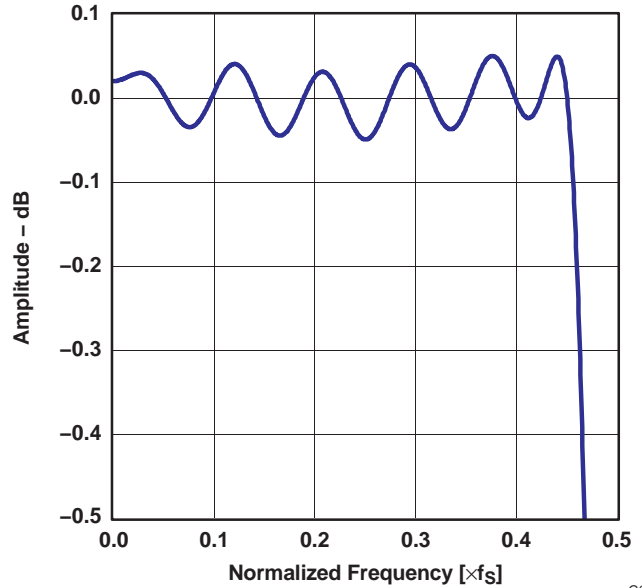

Figure 2.

#### ANALOG FILTER

HIGH-PASS FILTER CHARACTERISTICS

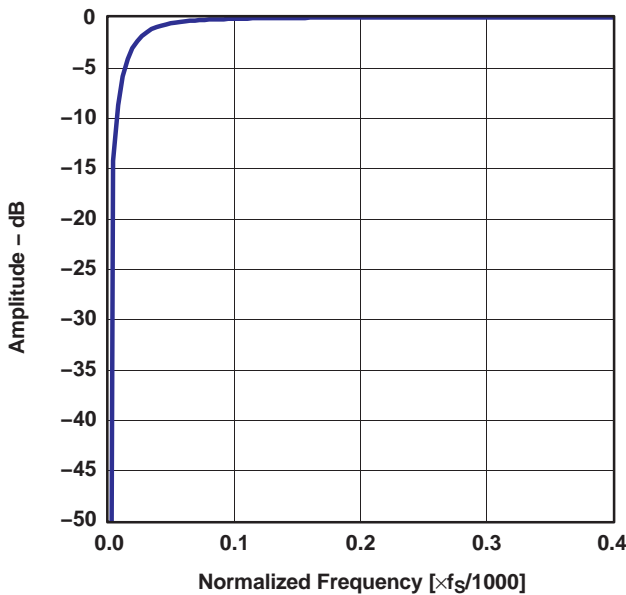

Figure 3.

ANTI\_ALIASING FILTER CHARACTERISTICS

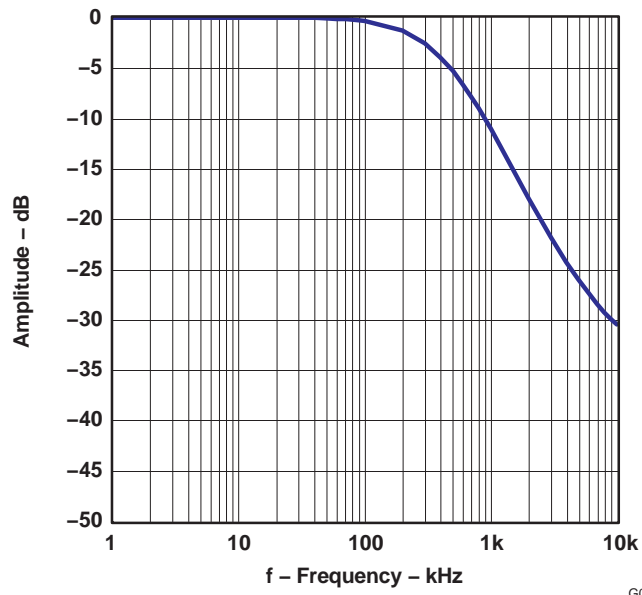

Figure 4.

## TYPICAL PERFORMANCE CURVES OF DAC INTERNAL FILTER

All specifications at  $T_A = 25^\circ\text{C}$ ,  $V_{CC} = 5\text{ V}$ ,  $V_{DD} = 3.3\text{ V}$ ,  $f_S = 48\text{ kHz}$ ,  $\text{SCK11} = \text{SCK12} = 512 f_S$ , 24-bit data, unless otherwise noted.

### DIGITAL FILTER

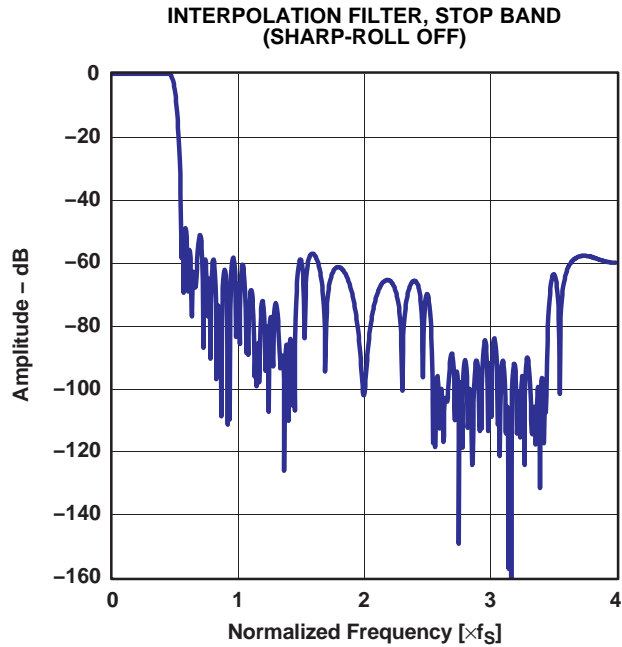

Figure 5.

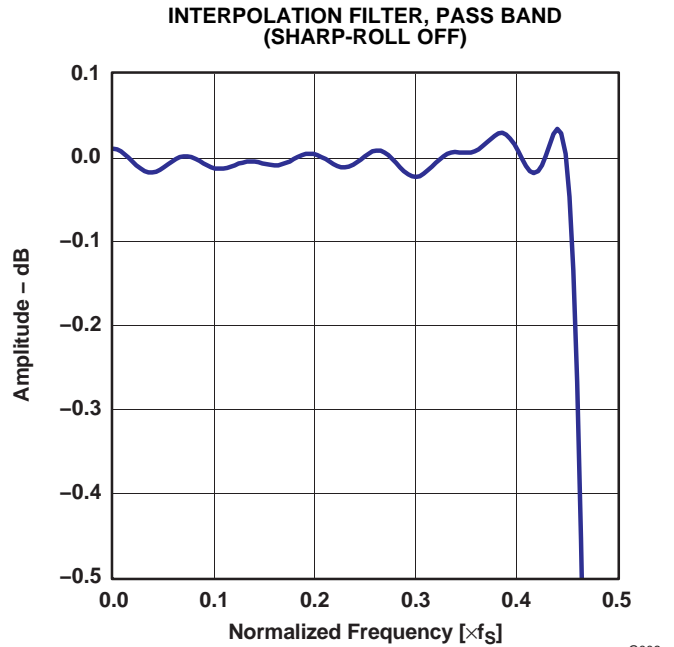

Figure 6.

### ANALOG FILTER

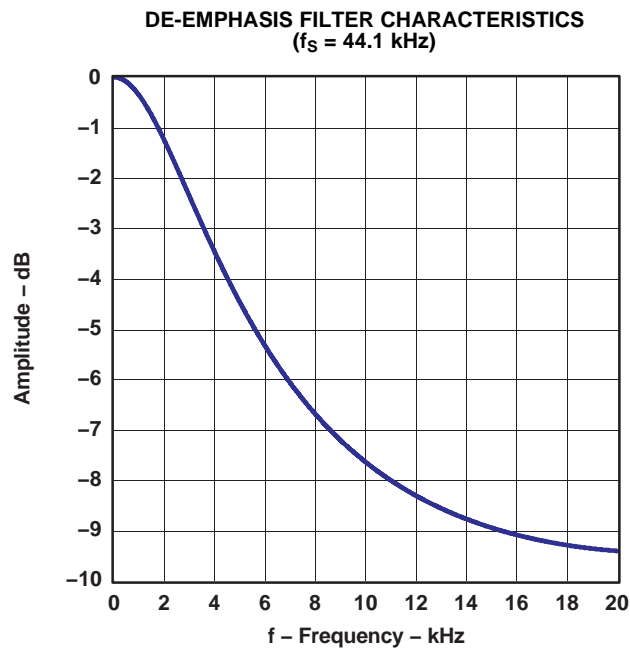

Figure 7.

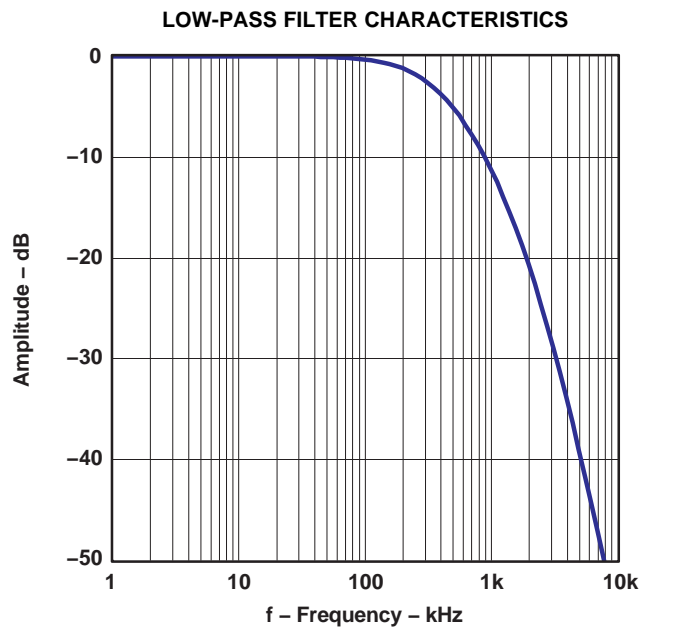

Figure 8.

### TYPICAL ADC PERFORMANCE CURVES

All specifications at  $T_A = 25^\circ\text{C}$ ,  $V_{CC} = 5\text{ V}$ ,  $V_{DD} = 3.3\text{ V}$ ,  $f_S = 48\text{ kHz}$ ,  $\text{SCK11} = \text{SCK12} = 512\text{ f}_S$ , 24-bit data, unless otherwise noted.

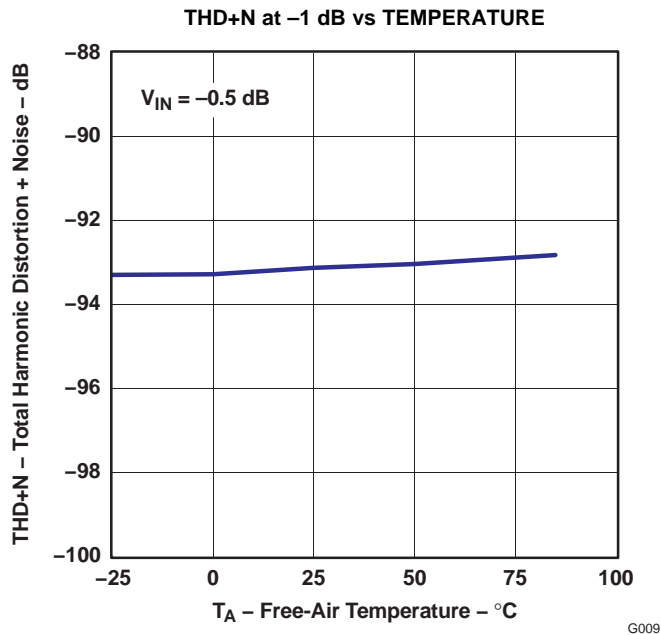

Figure 9.

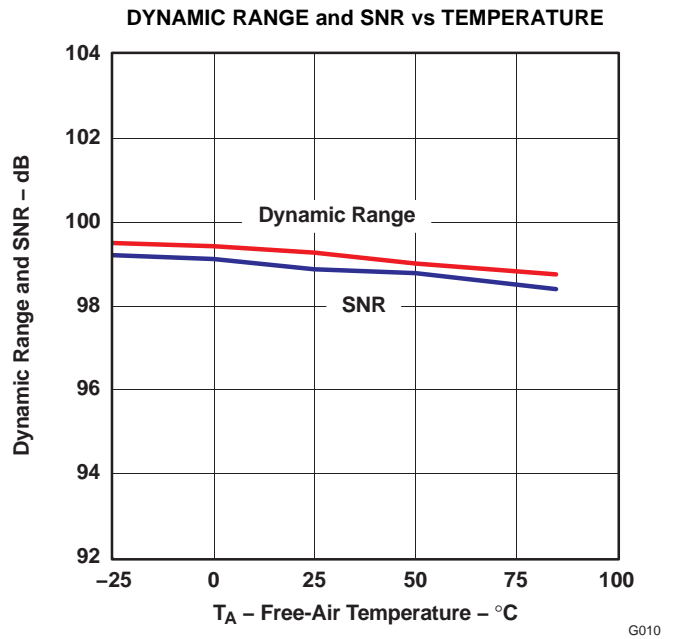

Figure 10.

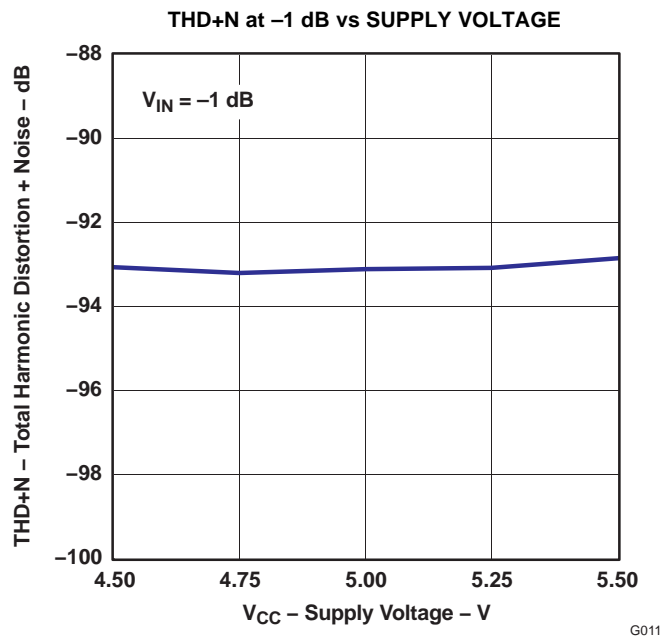

Figure 11.

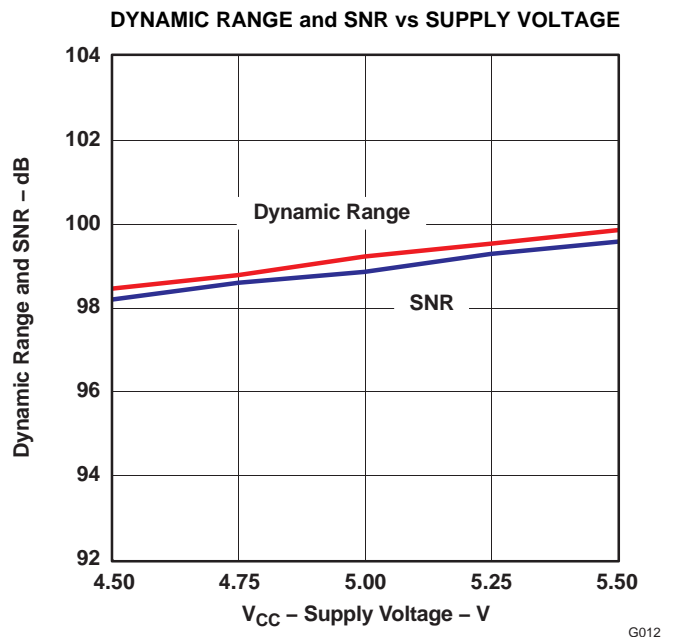

Figure 12.

### TYPICAL DAC PERFORMANCE CURVES

All specifications at  $T_A = 25^\circ\text{C}$ ,  $V_{CC} = 5\text{ V}$ ,  $V_{DD} = 3.3\text{ V}$ ,  $f_S = 48\text{ kHz}$ ,  $\text{SCK11} = \text{SCK12} = 512 f_S$ , 24-bit data, unless otherwise noted.

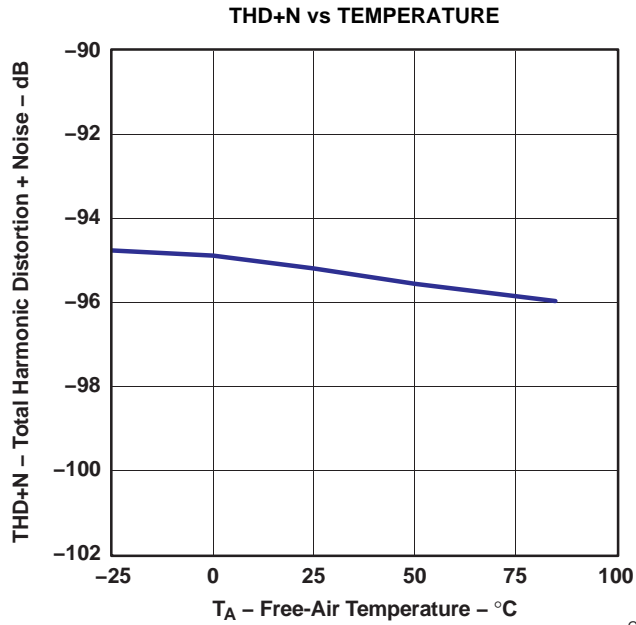

Figure 13.

G013

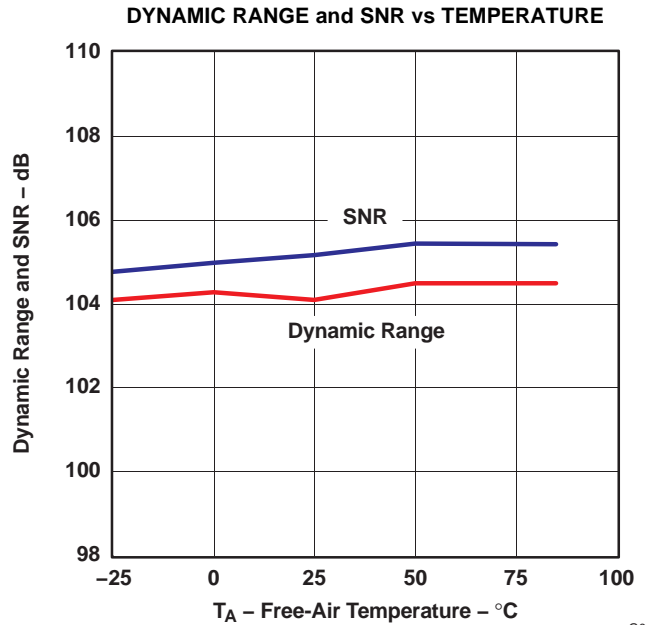

Figure 14.

G014

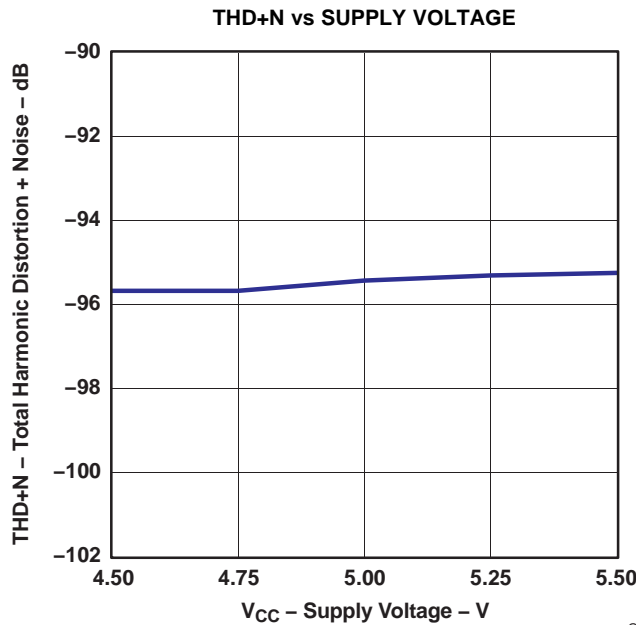

Figure 15.

G015

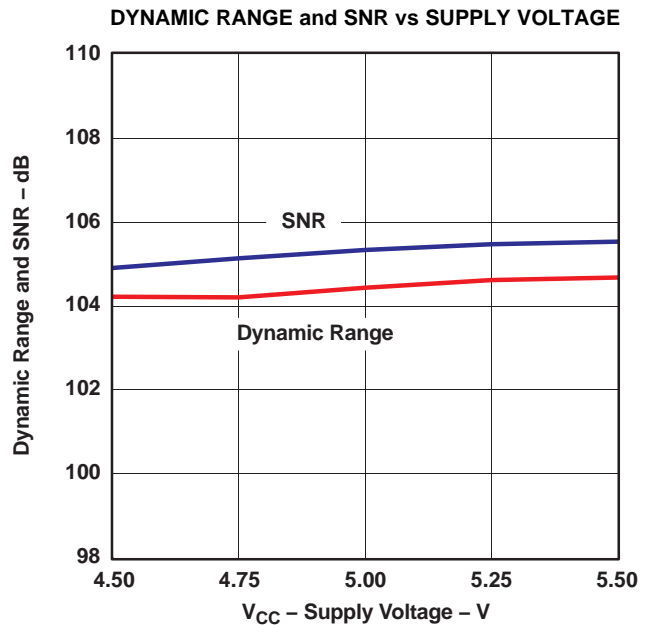

Figure 16.

G016

### TYPICAL PERFORMANCE CURVES

All specifications at  $T_A = 25^\circ\text{C}$ ,  $V_{CC} = 5\text{ V}$ ,  $V_{DD} = 3.3\text{ V}$ ,  $f_S = 48\text{ kHz}$ ,  $\text{SCKI1} = \text{SCKI2} = 512 f_S$ , 24-bit data, unless otherwise noted.

#### ADCs OUTPUT SPECTRUM

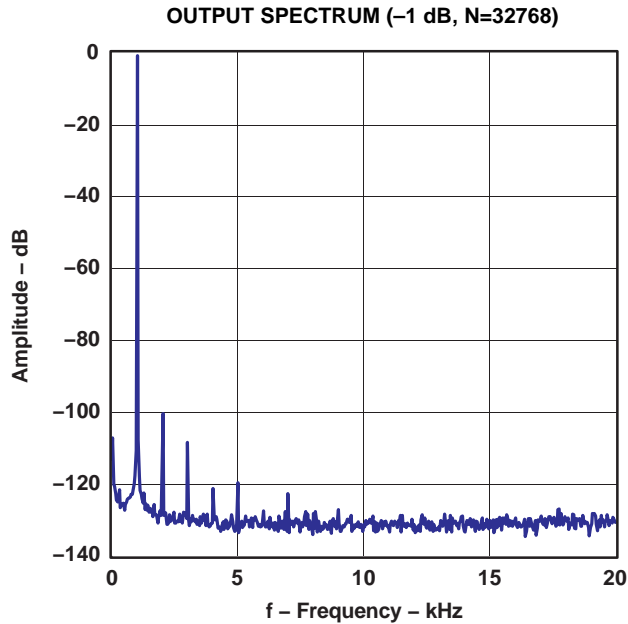

Figure 17.

G017

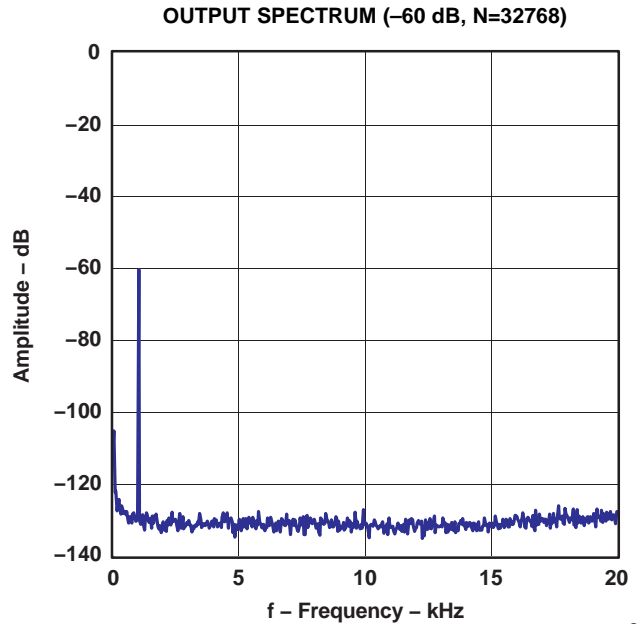

Figure 18.

G018

#### DAC OUTPUT SPECTRUM

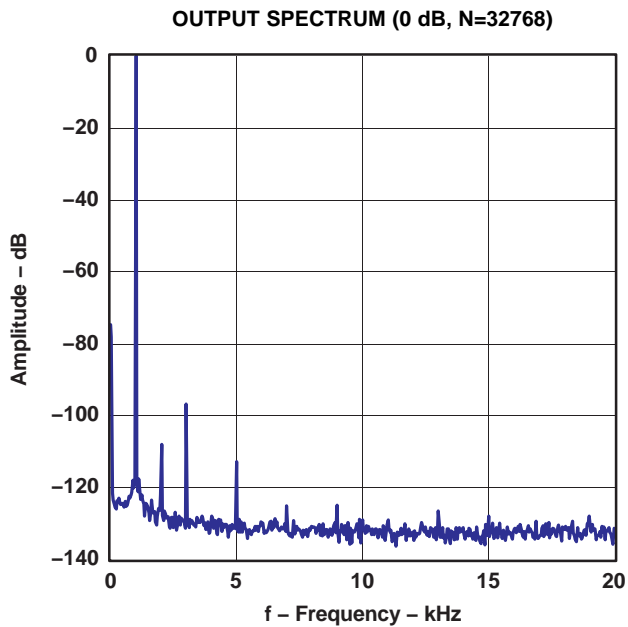

Figure 19.

G019

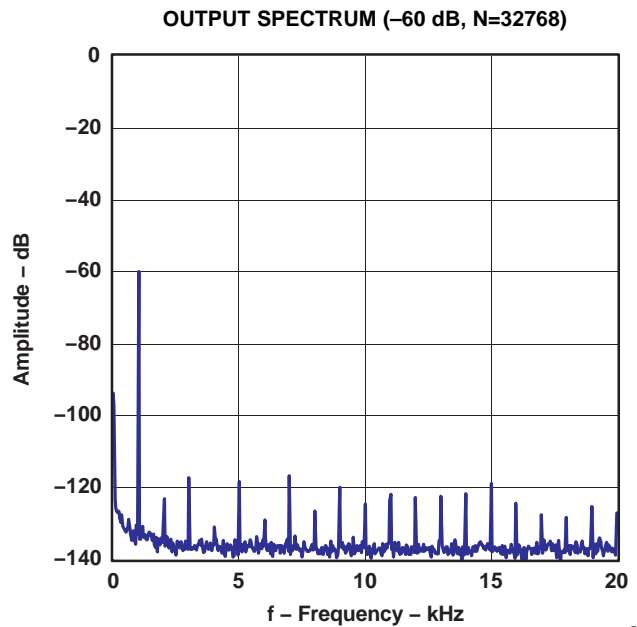

Figure 20.

G020

## DEVICE DESCRIPTION

### ASYNCHRONOUS OPERATION

The PCM3060 supports complete asynchronous operation between the ADC and DAC by receiving two independent system clocks on SCK11 and SCK12.

Also, the PCM3060 supports synchronous operation between ADC and DAC by receiving one common system clock on either SCK11 or SCK12 and controlling the system clock configuration through register 67 or 72 in serial mode control.

### SYSTEM CLOCK

The PCM3060 requires two system clocks for operating the ADC and DAC blocks independently, or it requires one common clock for synchronous ADC and DAC operation.

The system clock for the ADC of the PCM3060 must be 256, 384, 512, or 768  $f_s$ , where  $f_s$  is the audio sampling rate for the ADC, 16 to 96 kHz.

The system clock for the DAC of the PCM3060 must be 128, 192, 256, 384, 512, or 768  $f_s$ , where  $f_s$  is the audio sampling rate for the DAC, 16 to 192 kHz.

Table 2 lists the typical system clock frequencies,  $f_{SCK11}$  and  $f_{SCK12}$  for common audio sampling rates, and Figure 21 shows the timing requirements for the system clock inputs.

**Table 2. System Clock Frequencies for Common Audio Sampling Clock Frequencies**

SAMPLING FREQUENCY (kHz)	SYSTEM CLOCK FREQUENCY, $f_{SCK11}$ , $f_{SCK12}$ [MHz]					
	128 $f_s$ <sup>(1)</sup>	192 $f_s$ <sup>(1)</sup>	256 $f_s$	384 $f_s$	512 $f_s$	768 $f_s$
16	2.048	3.072	4.096	6.144	8.192	12.288
32	4.096	6.144	8.192	12.288	16.384	24.576
44.1	5.6488	8.4672	11.2896	16.9344	22.5792	33.8688
48	6.144	9.216	12.288	18.432	24.576	36.864
88.2	11.2896	16.9344	22.5792	33.8688	See <sup>(2)</sup>	See <sup>(2)</sup>
96	12.288	18.432	24.576	36.864	See <sup>(2)</sup>	See <sup>(2)</sup>
176.4 <sup>(1)</sup>	22.5792	33.8688	See <sup>(2)</sup>	See <sup>(2)</sup>	See <sup>(2)</sup>	See <sup>(2)</sup>
192 <sup>(1)</sup>	24.576	36.864	See <sup>(2)</sup>	See <sup>(2)</sup>	See <sup>(2)</sup>	See <sup>(2)</sup>

(1) This combination of sampling clock frequency and system clock frequency is supported only for the DAC.

(2) This system clock frequency is not supported for the given sampling clock frequency.

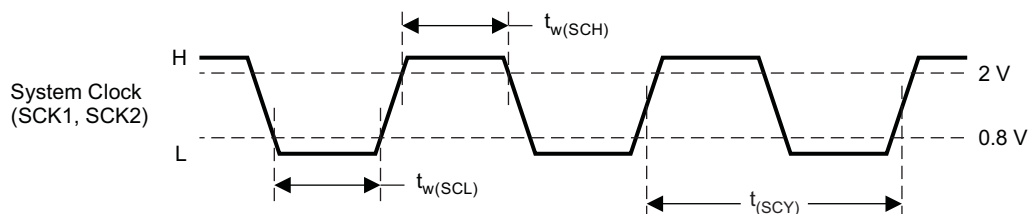

T0005-14

SYMBOL	PARAMETERS	MIN	MAX	UNIT
$t_{(SCY)}$	System clock cycle time	25		ns
$t_{w(SCH)}$	System clock high time	0.4 $t_{(SCY)}$		ns
$t_{w(SCL)}$	System clock low time	0.4 $t_{(SCY)}$		ns
	System clock duty cycle	40%	60%	

**Figure 21. System Clock Input Timing**

## POWER-ON RESET AND EXTERNAL RESET SEQUENCE

The PCM3060 has both an internal power-on reset circuit and an external reset circuit. The sequences for both resets are shown in the following.

**Figure 22** illustrates the timing of the internal power-on reset. Initialization (reset) is done automatically at the time when  $V_{DD}$  exceeds 2.2 V typical.

Internal reset is released 1024 SCKIx ( $x = 1, 2$ ) after power on if the H/W control mode is selected and  $\overline{RST}$  is kept HIGH; then the PCM3060 begins normal operation. If the S/W control mode is selected and  $\overline{RST}$  is kept HIGH, internal reset is released 1024 SCKIx after the reset of ADPSV and DAPSV through serial control port; then the PCM3060 begins normal operation. If  $\overline{RST}$  is kept LOW, internal reset is held and the reset sequence is frozen until  $\overline{RST}$  is changed from LOW to HIGH.  $V_{OUTL}$  and  $V_{OUTR}$  from the DAC are forced to the  $V_{COM}$  ( $= 0.5 V_{CC}$ ) level as  $V_{CC}$  rises. If synchronization is maintained among SCKIx, BCKx, and LRCKx,  $V_{OUTL}$  and  $V_{OUTR}$  go into the fade-in sequence after  $t_{DACDLY1} = 2048/f_S$  from internal reset release. Then  $V_{OUTL}$  and  $V_{OUTR}$  provide outputs corresponding to DIN after  $t_{DACDLY2} = 1616/f_S$  from the start of fade-in. Similarly, DOUT from the ADC is enabled and goes into the fade-in sequence after  $t_{ADC DLY1} = 2048/f_S$  from internal reset release, and then DOUT provides an output corresponding to  $V_{INL}$  and  $V_{INR}$  after  $t_{ADC DLY2} = 1936/f_S$  from the start of fade-in. If synchronization is not held, the internal reset is not released and operation mode is kept on reset and power-down state. After resynchronization, the DAC begins its fade-in sequence, and the ADC also begins fade-in operation after internal initialization and an initial delay.

**Figure 23** is the timing chart of the external reset. The  $\overline{RST}$  pin initiates external forced reset when  $\overline{RST}$  is held LOW for at least  $t_{RST} = 2048/f_S$ ; it resets the device places it in the power-down state, which is the lowest-power dissipation state in the PCM3060.

When  $\overline{RST}$  transitions from HIGH to LOW while SCKIx, BCKx, and LRCKx are synchronized,  $V_{OUTL}$  and  $V_{OUTR}$  are forced to the  $V_{COM}$  ( $= 0.5 V_{CC}$ ) level after the fade-out sequence lasting  $t_{DACDLY2} = 1616/f_S$ , and DOUT is forced to ZERO after  $t_{ADC DLY2} = 1936/f_S$  fade-out sequence. After that, the internal reset becomes LOW, the PCM3060 resets and enters into the power-down state, finally all registers and memory except mode control registers are reset. To resume into normal operation, changing  $\overline{RST}$  to HIGH again is required, and the sequence shown in **Figure 22** is performed. It is possible to halt SCKIx, BCKx and LRCKx during the power-down state, but all clocks must be resumed prior to starting the power-up sequence. The same fade-in/-out sequence of  $V_{OUTL/R}$  and DOUT can be obtained by setting the ADPSV and DAPSV bits through serial mode control port.

**POWER-ON RESET AND EXTERNAL RESET SEQUENCE (Continued)**

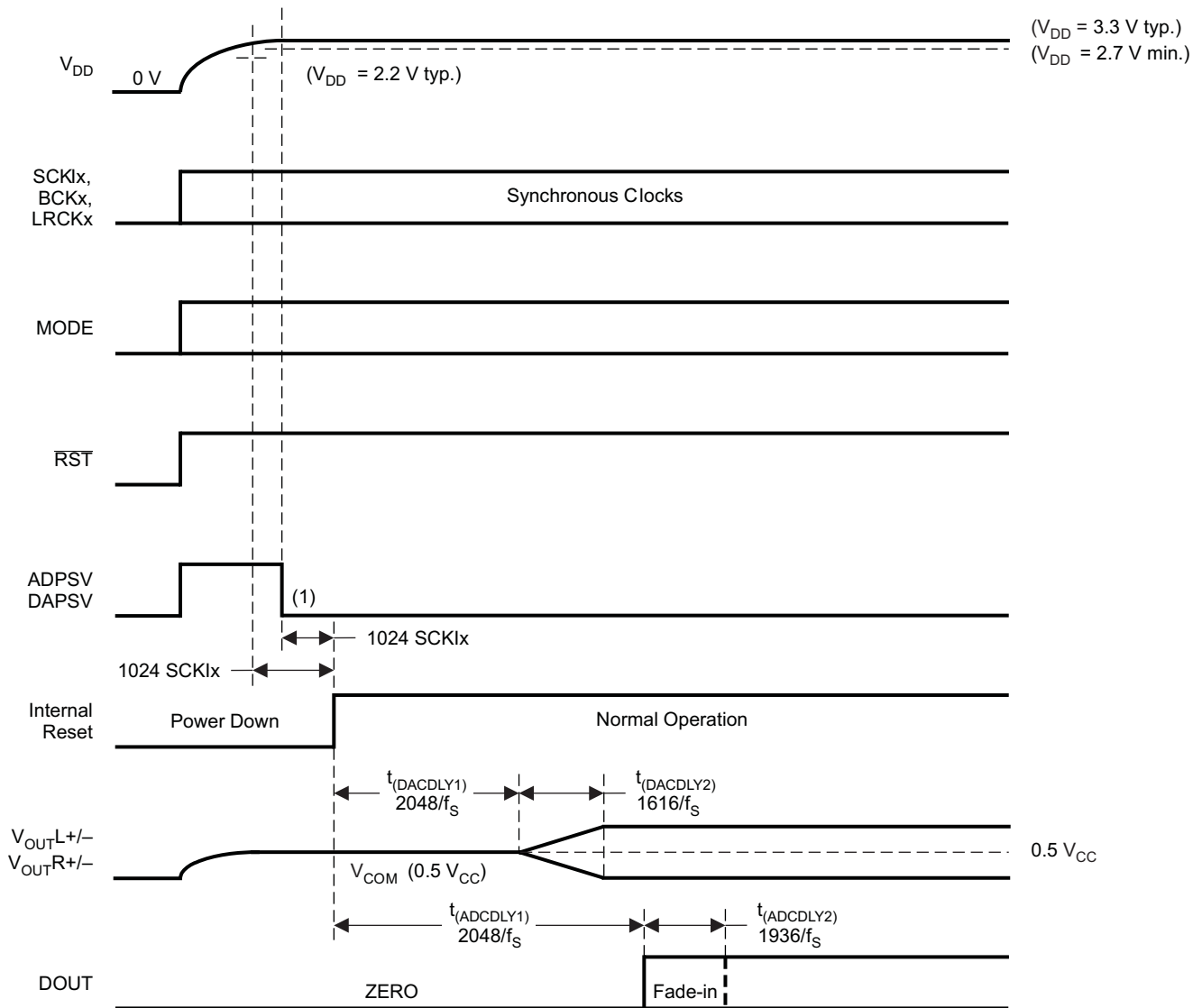

T0097-02

NOTE: Release from the power-save mode is required if the software control mode is selected.

**Figure 22. DAC Output and ADC Output for Power-On Reset**

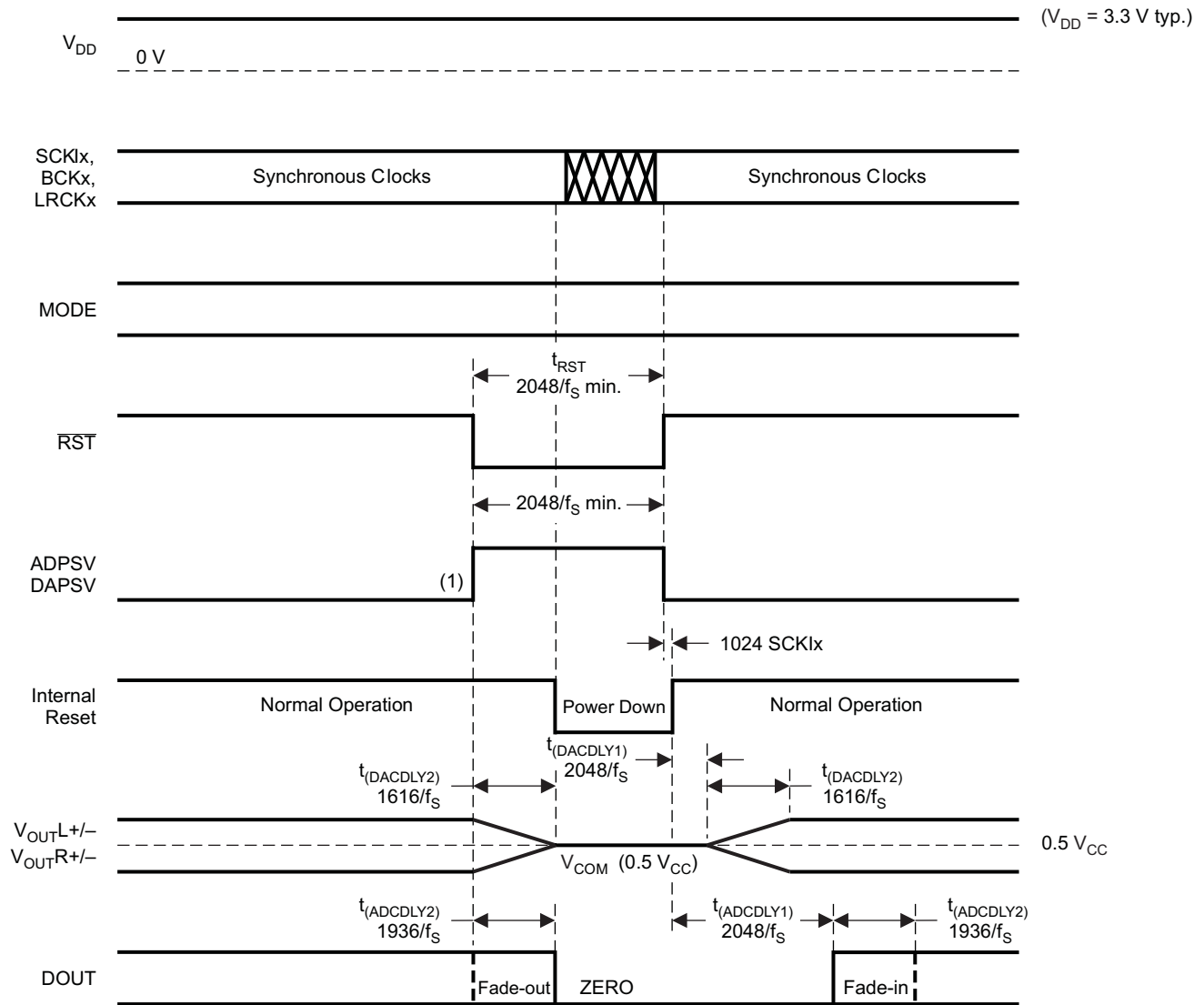

T0098-02

(1) ADPSV and DAPSV control V<sub>OUTL/R</sub> and DOUT, respectively, with fade-in/out the same as for  $\overline{RST}$ .

**Figure 23. DAC Output and ADC Output for External Reset**

## PCM AUDIO INTERFACE

### Audio Interface Mode and Timing

The digital audio data can be interfaced in either slave or master mode, and this interface mode is selectable using the serial mode control described in the Mode Control section.

The interface mode is also selectable independently for the ADC and the DAC. DIN is always input to the PCM3060 and DOUT is always an output from the PCM3060. Slave mode is the default mode for both the ADC and the DAC.

In slave mode, BCK1/2 and LRCK1/2 are inputs to the PCM3060, and BCK1/2 must be either  $64 f_s$  or  $48 f_s$ . DIN is sampled on the rising edge of BCK2, and DOUT is changed on the falling edge of BCK1. The default timing specification is shown in Figure 24.

In master mode, BCK1/2 and LRCK1/2 are outputs from the PCM3060. BCK1/2 and LRCK1/2 are generated by the PCM3060 from SCK11/2, and BCK1/2 is fixed at  $64 f_s$ . DIN is sampled on the rising edge of BCK2, and DOUT is changed on the falling edge of BCK1. The detailed timing specification is shown in Figure 25.

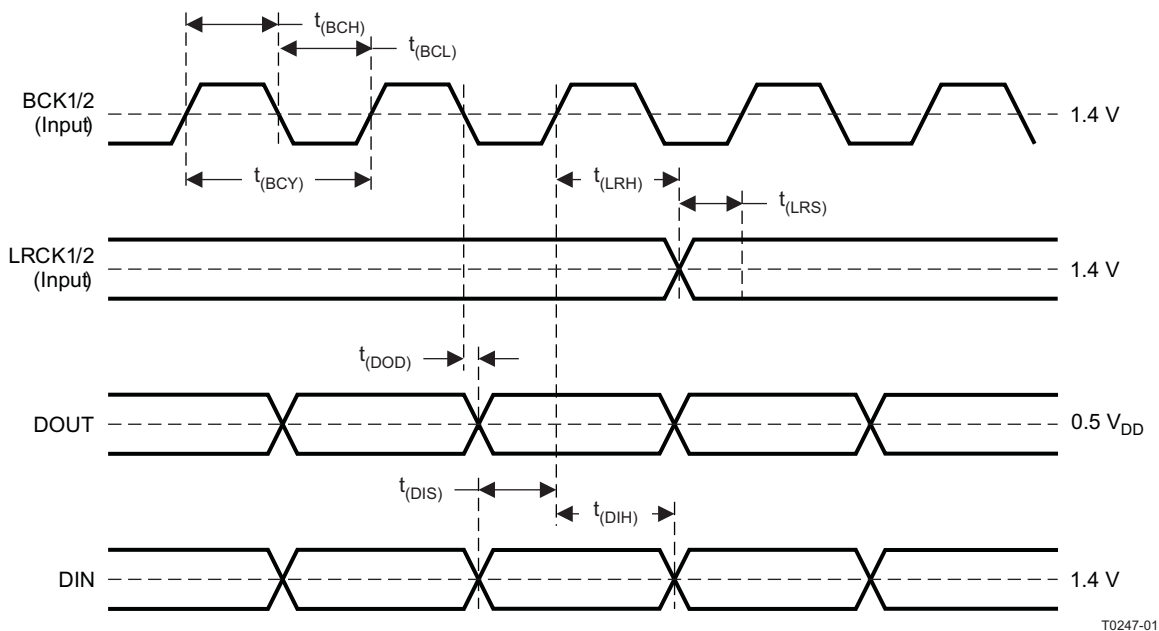

SYMBOL	DESCRIPTION	MIN	TYP	MAX	UNIT
$t_{(BCY)}$	BCK1/2 cycle time	75			ns
$t_w(BCH)$	BCK1/2 high time	35			ns
$t_w(BCL)$	BCK1/2 low time	35			ns
$t_{(LRS)}$	LRCK1/2 set-up time to BCK1/2 rising edge	10			ns
$t_{(LRH)}$	LRCK1/2 hold time to BCK1/2 rising edge	10			ns
$t_{(DIS)}$	DIN setup time to BCK1/2 rising edge	10			ns
$t_{(DIH)}$	DIN hold time to BCK1/2 rising edge	10			ns
$t_{(DOD)}$	DOUT delay time from BCK1/2 falling edge	15		70	ns

NOTE: Load capacitance of output is 20 pF.

**Figure 24. Audio Data Interface Timing (Slave Mode: BCK1/2 and LRCK1/2 Work as Inputs)**

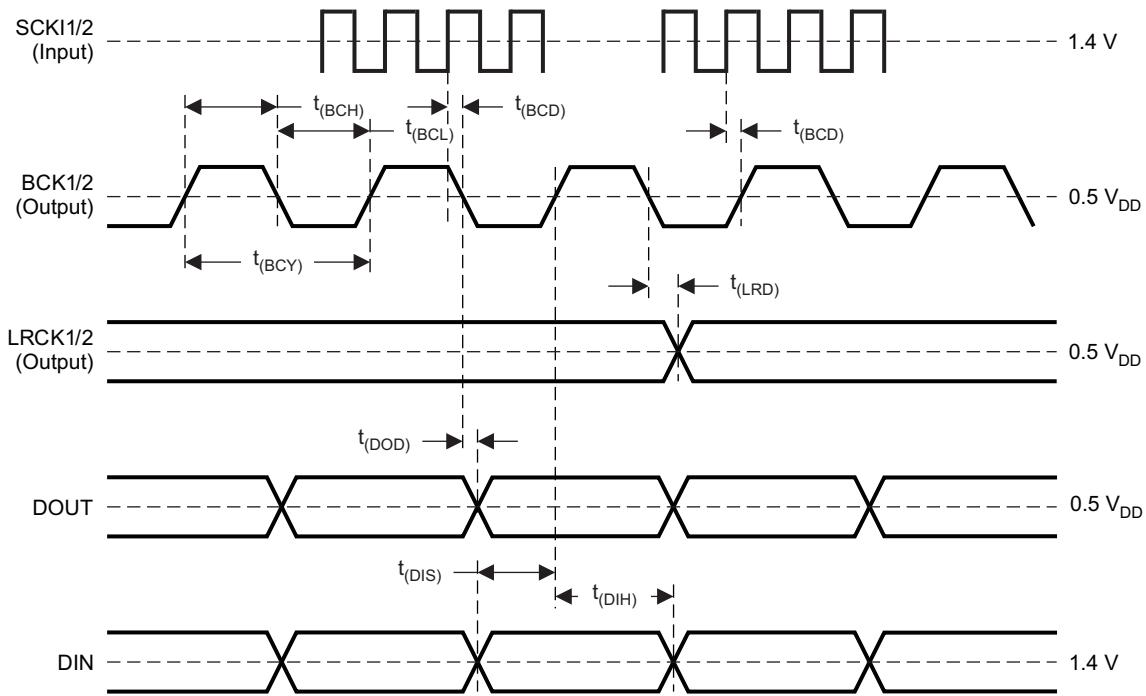

T0248-01

SYMBOL	PARAMETERS	MIN	TYP	MAX	UNIT
$t_{(BCY)}$	BCK1/2 cycle time	$1/64 f_S$			
$t_{w(BCH)}$	BCK1/2 high time	$0.4 t_{(BCY)}$	$0.5 t_{(BCY)}$	$0.6 t_{(BCY)}$	
$t_{w(BCL)}$	BCK1/2 low time	$0.4 t_{(BCY)}$	$0.5 t_{(BCY)}$	$0.6 t_{(BCY)}$	
$t_{(LRD)}$	LRCK1/2 delay time from BCK1/2 falling edge	0		30	ns
$t_{(DIS)}$	DIN setup time to BCK1/2 rising edge	10			ns
$t_{(DIH)}$	DIN hold time to BCK1/2 rising edge	10			ns
$t_{(DOD)}$	DOUT delay time from BCK1/2 falling edge	0		30	ns
$t_{(BCD)}$	BCK1/2 delay time from SCK1/2 rising edge <sup>(1)</sup>	10		40	ns

NOTE: Load capacitance of output is 20 pF.

(1) This specification applies for SCK1/2 when the frequency is less than 25 MHz.

**Figure 25. Audio Data Interface Timing (Master Mode: BCK1/2 and LRCK1/2 work as Outputs)****Audio Interface Format**

The PCM3060 supports the following four interface formats in both slave and master modes, and they are selectable independently for the ADC and DAC using serial mode control.

- 24-bit I<sup>2</sup>S format
- 24-bit left-justified format
- 24-bit right-justified format
- 16-bit right-justified format

All formats are provided in MSB-first, 2s complement data format.

**FMT1/2[1:0] = 00**

24-Bit, MSB-First, I<sup>2</sup>S

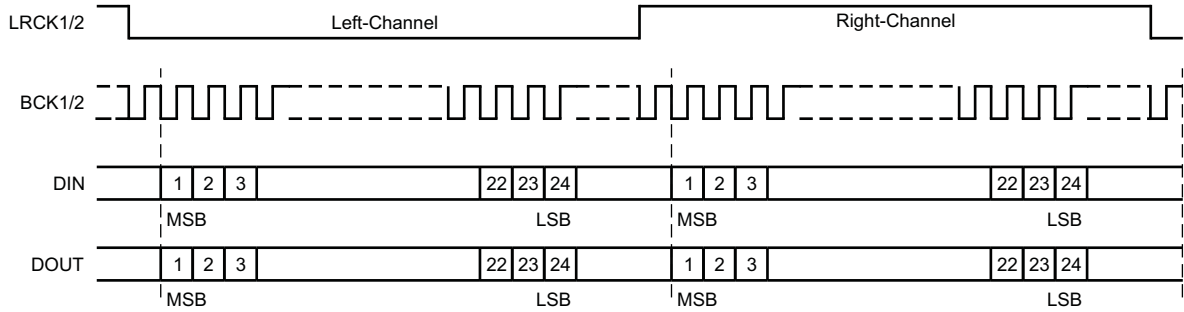

**FMT1/2[1:0] = 01**

24-Bit, MSB-First, Left-Justified

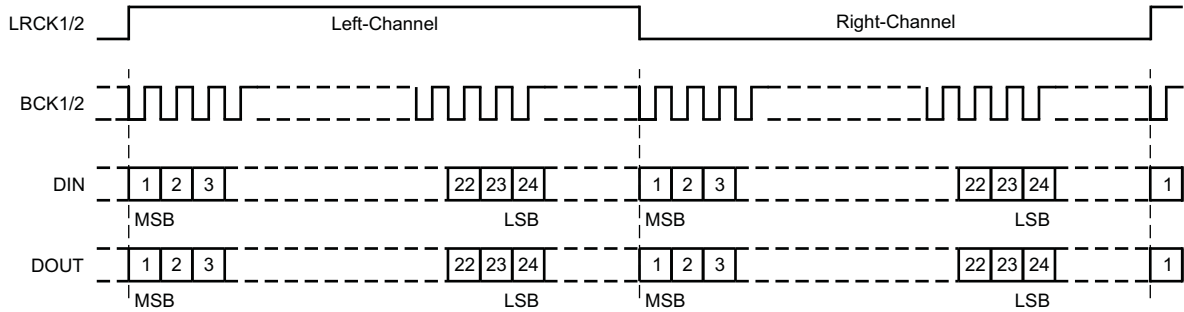

**FMT1/2[1:0] = 10**

24-Bit, MSB-First, Right-Justified

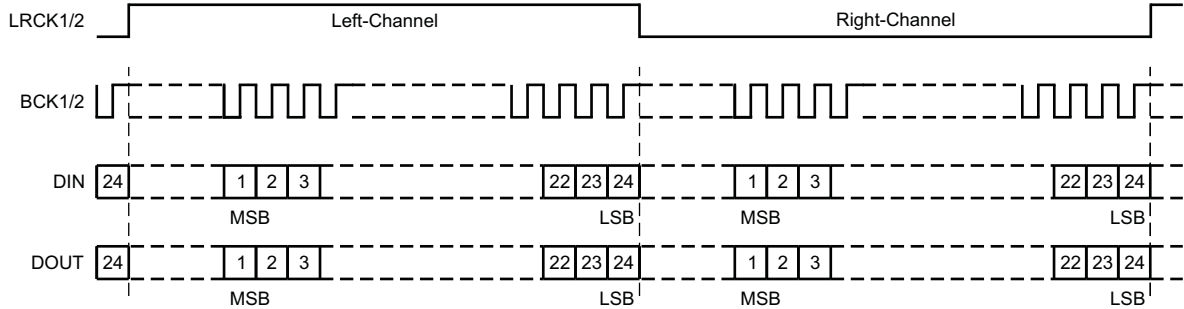

**FMT1/2[1:0] = 11**

16-Bit, MSB-First, Right-Justified

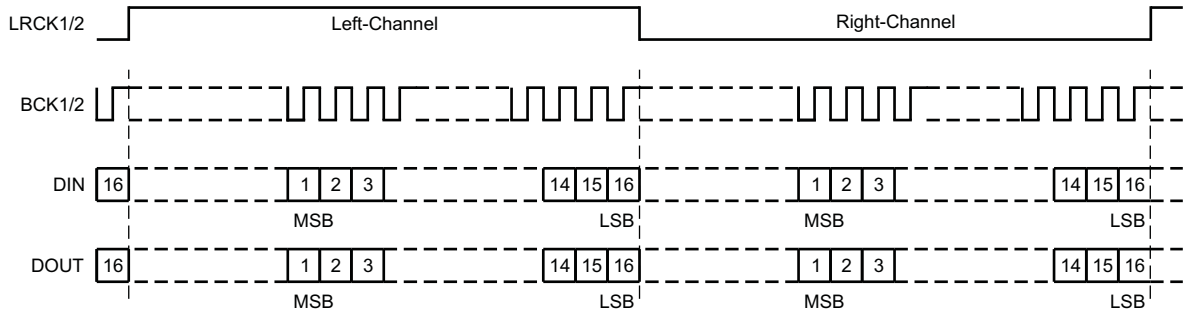

T0016-18

**Figure 26. Audio Data Input/Output Format**

## SYNCHRONIZATION WITH DIGITAL AUDIO SYSTEM

As the PCM3060 operates under the system clock (SCK1/2) and the audio sampling clock (LRCK1/2), SCK1/2 and LRCK1/2 must have a specific relationship in slave mode. The PCM3060 does not need a specific phase relationship between audio the interface clocks (LRCK1/2, BCK1/2) and system clock (SCK1/2), but does require a frequency synchronization of LRCK1/2, BCK1/2, and SCK1/2.

If the relationship between SCK12 and LRCK2 changes more than  $\pm 6$  BCK2s ( $BCK2 = 64 f_s$ ) or  $\pm 5$  BCK2s ( $BCK2 = 48 f_s$ ) due to jitter or frequency change, etc., internal operation of DAC halts within  $2/f_s$ , and analog output is forced to  $V_{COM}$  ( $0.5V_{CC}$ ) until resynchronization of SCK12 to LRCK2 and BCK2 is completed and then  $t_{DACDLY3}$  passes by.

If the relationship between SCK11 and LRCK1 changes more than  $\pm 6$  BCK1s ( $BCK1 = 64 f_s$ ) or  $\pm 5$  BCK1s ( $BCK1 = 48 f_s$ ) due to jitter, frequency change, etc., internal operation of ADC halts within  $2/f_s$ , and digital output is forced into ZERO code until resynchronization of SCK11 to LRCK1 and BCK1 is completed and then  $t_{ADC DLY3}$  passes by.

In case of changes less than  $\pm 5$  BCK1/2s ( $BCK1/2 = 64$ ) or  $\pm 4$  BCK1/2s ( $BCK1/2 = 48$ ), resynchronization does not occur, and previously described analog/digital output control and discontinuity do not occur.

Figure 27 illustrates the DAC analog output and ADC digital output for loss of synchronization.

During undefined data, it may generate some noise in audio signal. Also, the transition of normal to undefined data and undefined or zero data to normal creates a discontinuity in the data on the analog and digital outputs, which may generate some noise in the audio signal.

The ADC output, DOUT and DAC outputs, and  $V_{OUTX}$  hold the previous state if the system clock halts.

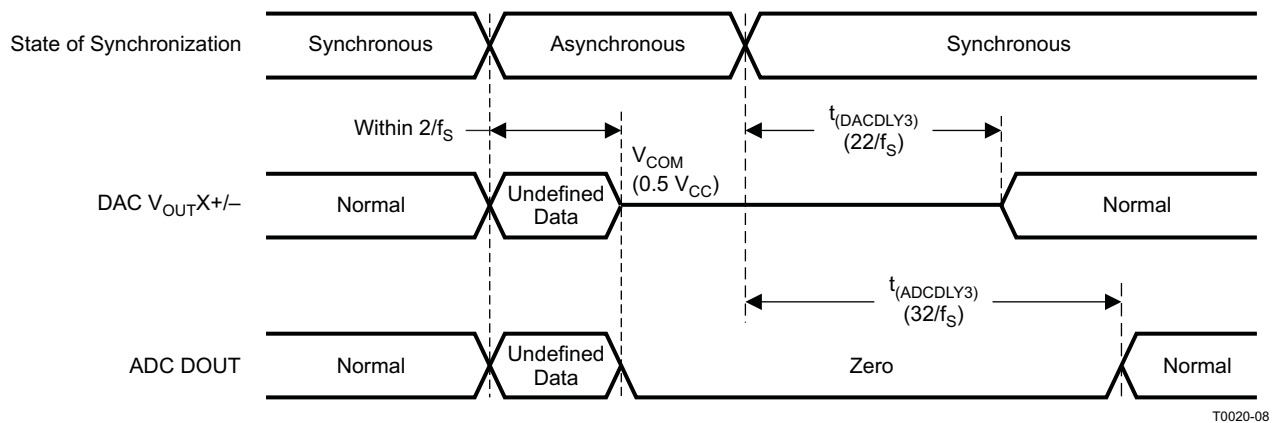

Figure 27. DAC Output and ADC Output for Loss of Synchronization

## ANALOG INPUTS TO ADC

The PCM3060 has two independent input channels,  $V_{INL}$  and  $V_{INR}$ . These are single-ended (unbalanced) inputs, each capable of  $0.6 \cdot V_{CC}$  Vpp input with 10-k $\Omega$  input resistance, typically.

## ANALOG OUTPUTS FROM DAC

The PCM3060 has two independent output channels,  $V_{OUTL}$  and  $V_{OUTR}$ . These are differential, (balanced) outputs, each capable of driving  $0.8 \cdot V_{CC}$  Vpp (1.6-Vpp in differential) typical with a 10-k $\Omega$  dc-coupled load. The internal output amplifiers for  $V_{OUTL+}$ ,  $V_{OUTL-}$  and  $V_{OUTR+}$ ,  $V_{OUTR-}$  are biased to  $V_{COM}$ , described as follows.

The output amplifiers include an RC continuous-time filter, which helps to reduce the out-of-band noise energy present at the DAC outputs due to the noise shaping characteristics of the PCM3060 delta-sigma modulators. The frequency response of this filter is shown in the typical performance curves. This filter is not enough to attenuate the out-of-band noise to an acceptable level for many applications in general. An external low-pass filter is used if further out-of-band noise rejection is required.

$V_{OUTX+}$ ,  $V_{OUTX-}$  configuration can be changed to single-ended (unbalanced) output via a MODE pin setting or serial mode control, and  $V_{OUTX+}$  is assigned as an output pin in single-ended mode.

## $V_{COM}$ OUTPUT

One unbuffered common voltage output pin, VCOM (pin 20) is brought out for decoupling purposes. This pin is internally biased to a dc voltage level of  $0.5 V_{CC}$  nominal, and is used as an internal common voltage and reference voltage for the ADC and DAC. This pin can be used to bias an external circuit, but the load impedance must be high enough for operation with the output resistance of this pin, which is 12.5 k $\Omega$ , typically.

## OVERSAMPLING RATE CONTROL

The oversampling rate of ADC of PCM3060 is fixed at  $64 f_S$ , but the oversampling rate of DAC of PCM3060 is one of  $64 f_S$ ,  $32 f_S$  or  $16 f_S$ , and this is automatically selected by the ratio of system clock frequency and sampling frequency. And it can be also set to double rate, i.e., one of  $128 f_S$ ,  $64 f_S$  or  $32 f_S$ , through serial control.

## ZERO FLAGS

### Zero-Detect Condition

For each DAC channel, the PCM3060 has a zero-detect circuit that recognizes zero detection when 1024 consecutive zeros have been sampled on DIN.

### Zero-Flag Outputs

There are two zero-flag outputs, ZEROL and ZEROR. These pins can be used to operate external mute circuits, or used as status indicators for a microcontroller, audio signal processor, etc. These pins can be programmed in following two modes using the serial control port as described in the MODE CONTROL section.

AZRO	DESCRIPTION	
	ZEROL	ZEROR
0 (default)	L-ch zero detection	R-ch zero detection
1	L-ch and R-ch zero detection	L-ch and R-ch zero detection

For zero detection, these pins are set to HIGH (1) by default, but the polarity of the zero-flag outputs can be inverted through the serial control port.

ZREV	DESCRIPTION
0 (default)	HIGH for zero detection
1	LOW for zero detection

## MODE CONTROL

The PCM3060 supports the following three types of mode control interface and four types of operation configuration, according to the input state of MODE (pin 28) as follows. The pullup or pulldown resistor must be 220 k $\Omega$   $\pm$ 5%.

MODE	MODE CONTROL INTERFACE
Tie to DGND	2-wire (I <sup>2</sup> C) serial control, selectable V <sub>OUTX</sub> configuration
Pulldown resistor to DGND	3-wire parallel control, differential V <sub>OUTX</sub>
Pullup resistor to V <sub>DD</sub>	3-wire parallel control, single-ended V <sub>OUTX</sub>
Tie to V <sub>DD</sub>	3-wire (SPI) serial control, selectable V <sub>OUTX</sub> configuration

The input state of the MODE pin is sampled during power-on reset or external reset; therefore, an input change after reset is ignored until the next reset is performed.

The definitions (assignments) of the following three pins are changed by this control mode setting.

PIN	DEFINITION		
	SPI	I <sup>2</sup> C	H/W
2	MD	SDA	DEMP
1	MC	SCL	FMT
27	$\overline{MS}$	ADR	IFMD

In serial mode control, the actual mode control is performed by register write (and read) through an SPI- or I<sup>2</sup>C-compatible serial control port.

In parallel mode control, three specific functions are controlled directly through high/low settings of three specific pins.

## PARALLEL HARDWARE CONTROL

IFMD (Interface Mode)	DESCRIPTION
LOW	Slave mode for ADC, slave mode for DAC
HIGH	Master (256 f <sub>s</sub> ) mode for ADC, slave mode for DAC

The audio interface of the ADC and DAC can be independent from each other, but mode selection is applied on both.

FMT (Interface Format)	DESCRIPTION
LOW	24-bit I <sup>2</sup> S for ADC and DAC
HIGH	24-bit left-justified for ADC and DAC

The audio interface of the ADC and DAC can be independent from each other, but format selection is applied on both.

DEMP (De-emphasis)	DESCRIPTION
LOW	De-emphasis off
HIGH	De-emphasis on <sup>(1)</sup>

(1) The 44.1-kHz de-emphasis filter is always selected.

## 3-WIRE (SPI) SERIAL CONTROL

The PCM3060 supports SPI-compatible serial ports, which operate asynchronously to the audio serial interface. The control interface consists of MD, MC, and  $\overline{MS}$ . MD is the serial data input, used to program the mode control registers. MC is the serial bit clock, used to shift the data into the control port.  $\overline{MS}$  is the select input, used to enable the mode control port.

### Register Write Operation

All single-write operations via the serial control port use 16-bit data words. Figure 28 shows the control data word format. The most significant bit must be a 0. There are seven bits, labeled  $IDX[6:0]$ , that set the register index (address) for the write operation. The least significant eight bits,  $D[7:0]$ , contain the data to be written to the register specified by  $IDX[6:0]$ .

Figure 29 shows the functional timing diagram for single-write operations on the serial control port.  $\overline{MS}$  is held in the High state until a register is to be written. To start the register write cycle,  $\overline{MS}$  is set to the Low state. Sixteen clocks are then provided on  $MC$ , corresponding to the 16 bits of the control data word on  $MD$ . After the sixteenth clock cycle has completed,  $\overline{MS}$  is set to High to latch the data into the indexed mode control register.

The PCM3060 supports the multiple-write operation in addition to the single-write operation. Multiple write is performed by sending N-sets of 8-bit register data after the first 16 bits of register address and register data, while keeping the  $MC$  clock and  $\overline{MS}$  in the Low state. Closing the multiple-write operation is done by setting  $\overline{MS}$  to the High state.

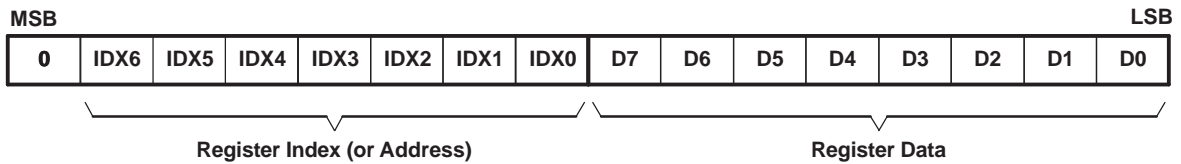

R0001-01

**Figure 28. Control Data Word Format for MD**

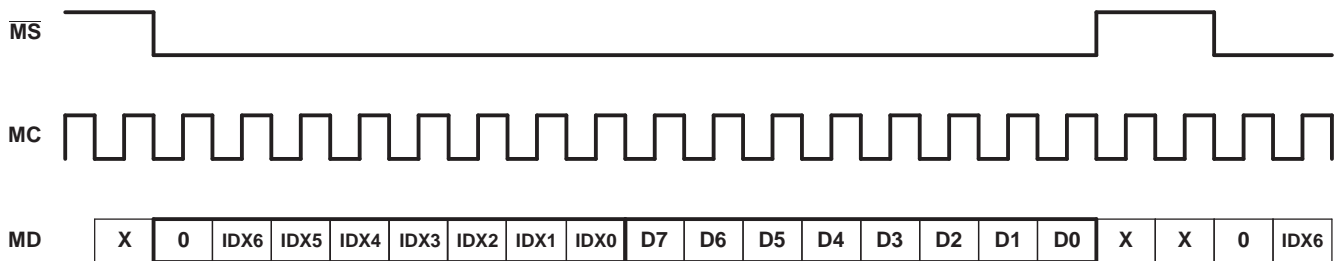

T0048-01

**Figure 29. Register Write Operation**

**Timing Requirements**

Figure 30 shows a detailed timing diagram for the 3-wire serial control interface. These timing parameters are critical for proper control port operation.

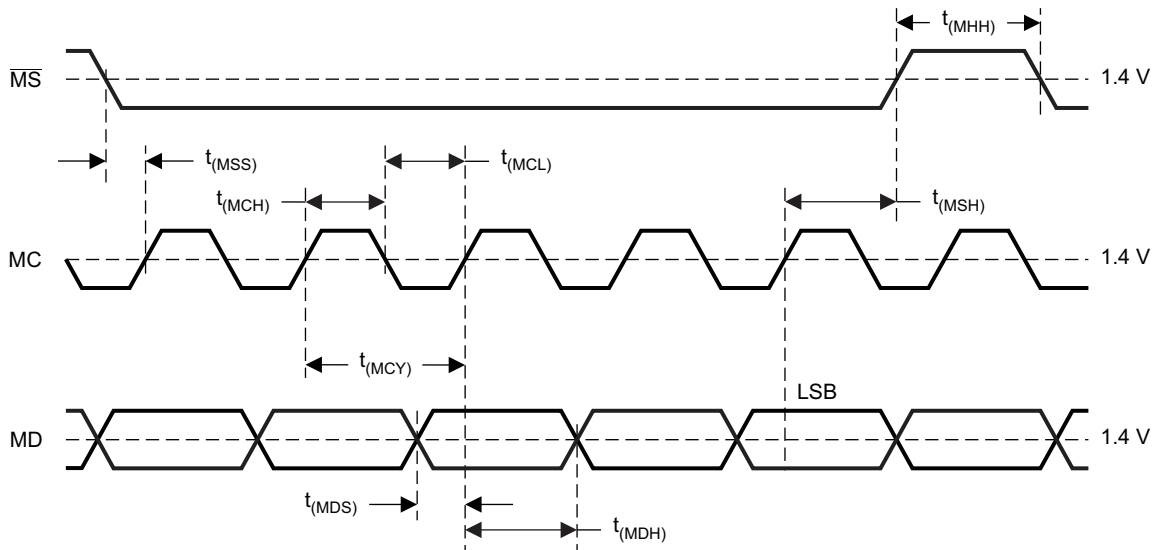

T0013-10

SYMBOL	PARAMETER	MIN	MAX	UNIT
$t_{(MCY)}$	MC cycle time	100		ns
$t_{w(MCL)}$	MC low-level time	40		ns
$t_{w(MCH)}$	MC high-level time	40		ns
$t_{(MHH)}$	$\overline{MS}$ high-level time	$t_{(MCY)}$		ns
$t_{(MSS)}$	$\overline{MS}$ falling edge to MC rising edge	15		ns
$t_{(MSH)}$	$\overline{MS}$ rising edge from MC rising edge for LSB <sup>(1)</sup>	15		ns
$t_{(MDH)}$	MD hold time	15		ns
$t_{(MDS)}$	MD setup time	15		ns

(1) MC rise edge for LSB to  $\overline{MS}$  rise edge.

**Figure 30. Control Interface Timing for SPI**

**TWO-WIRE (I<sup>2</sup>C) SERIAL CONTROL**

The PCM3060 supports the I<sup>2</sup>C-compatible serial bus and the data transmission protocol for standard-mode and fast-mode ( $C_B$  max = 100 pF) as a slave device. This protocol is explained in the well-known I<sup>2</sup>C 2.0 specification.

**Slave Address**

MSB						LSB	
1	0	0	0	1	1	ADR	R/W

The PCM3060 has 7 bits for its own slave address. The first six bits (MSBs) of the slave address are factory preset to 10 0011. The next bit of the address byte is the device select bit, which can be user-defined by the ADR pin (pin 27). Two PCM3060s at maximum can be connected on the same bus at one time. Each PCM3060 responds when it receives its own slave address.

### Packet Protocol

A master device must control packet protocol, which consists of a start condition, slave address with read/write bit, data if write or acknowledgment if read, and stop condition. The PCM3060 supports the slave receiver function.

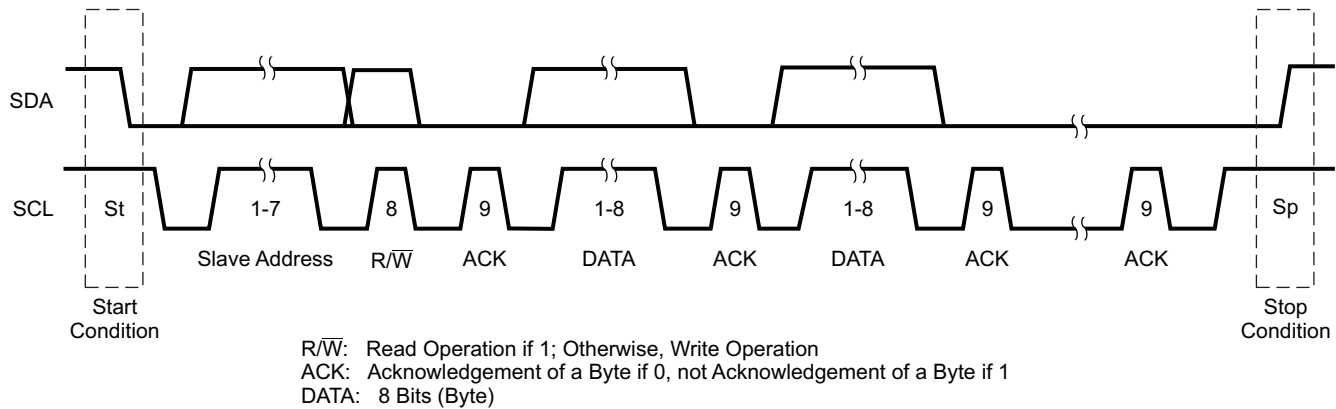

T0049-06

### Write Operation

The PCM3060 supports the receiver function. A master can write to any PCM3060 registers using single or multiple accesses. The master sends a PCM3060 slave address with a write bit, a register address, and the data. If multiple access is required, the address is that of the starting register, followed by the data to be transferred. When the data are received properly, the index register is incremented by 1 automatically. When the index register reaches 4Ah, the next value is 40h. When undefined registers are accessed, the PCM3060 does not send an acknowledgment. Figure 31 is a diagram of the write operation. The register address and the write data are 8-bit in MSB-first format.

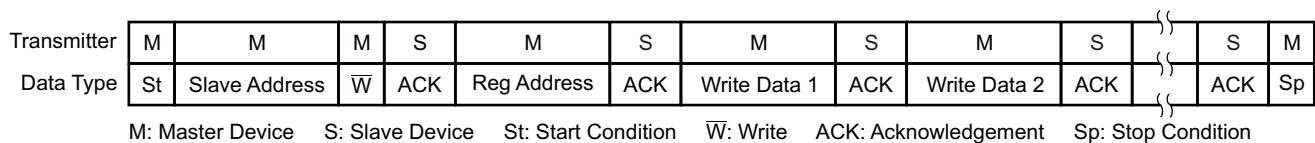

R0002-04

Figure 31. Framework for Write Operation

**Timing Diagram**

The detailed timing diagram for SCL and SDA is shown as follows.

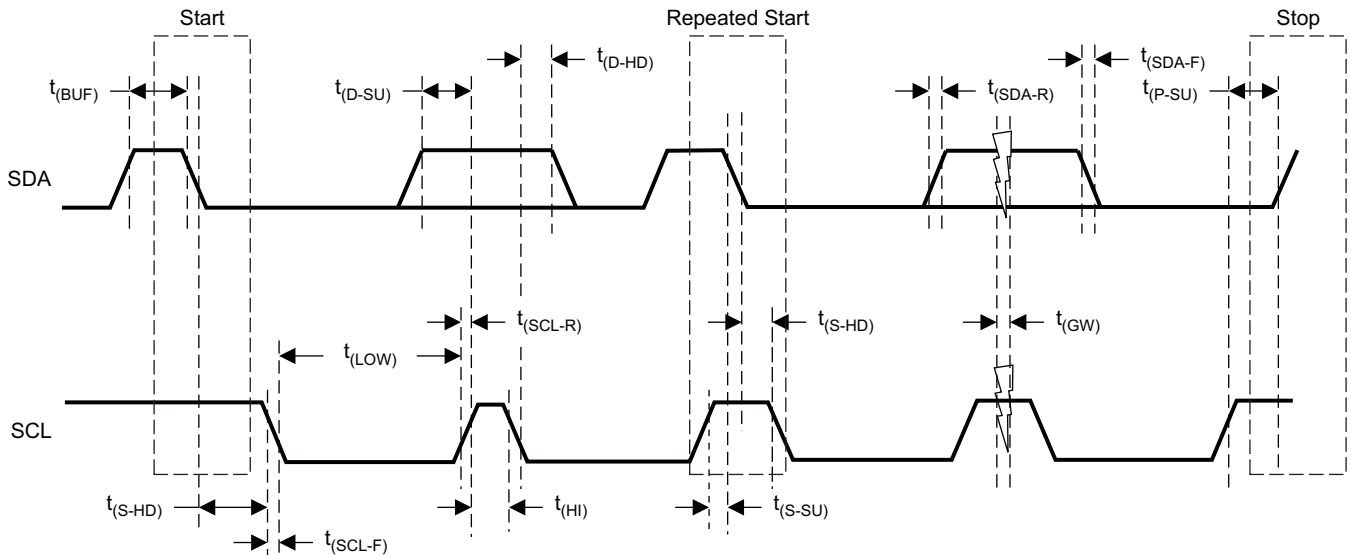

T0050-04

**Timing Characteristics**

SYMBOL	PARAMETER	STANDARD MODE		FAST MODE		UNIT
		MIN	MAX	MIN	MAX	
$f_{(SCL)}$	SCL clock frequency		100		400	kHz
$t_{(BUF)}$	Bus free time between STOP and START conditions	4.7		1.3		$\mu$ s
$t_{(LOW)}$	Low period of the SCL clock	4.7		1.3		$\mu$ s
$t_{(HI)}$	High period of the SCL clock	4		0.6		$\mu$ s
$t_{(S-SU)}$	Setup time for START/repeated START condition	4.7		0.6		$\mu$ s
$t_{(S-HD)}$	Hold time for START/repeated START condition	4		0.6		$\mu$ s
$t_{(D-SU)}$	Data setup time	250		100		ns
$t_{(D-HD)}$	Data hold time	0	3450	0	900	ns
$t_{(SCL-R)}$	Rise time of SCL signal		1000	$20 + 0.1 C_B$	300	ns
$t_{(SCL-F)}$	Fall time of SCL signal		1000	$20 + 0.1 C_B$	300	ns
$t_{(SDA-R)}$	Rise time of SDA signal		1000	$20 + 0.1 C_B$	300	ns
$t_{(SDA-F)}$	Fall time of SDA signal		1000	$20 + 0.1 C_B$	300	ns
$t_{(P-SU)}$	Setup time for STOP condition	4		0.6		$\mu$ s
$t_{(GW)}$	Allowable glitch width		N/A		50	ns
$C_B$	Capacitive load for SDA and SCL lines		400		100	pF
	Noise margin at high level for each connected device (including hysteresis)	$0.2 V_{DD}$		$0.2 V_{DD}$		V
	Noise margin at low level for each connected device (including hysteresis)	$0.1 V_{DD}$		$0.1 V_{DD}$		V
	Hysteresis of Schmitt-trigger input	N/A		$0.05 V_{DD}$		V

**Figure 32. Control Interface Timing for I<sup>2</sup>C**

## MODE CONTROL REGISTERS

The PCM3060 has many user-programmable functions which are accessed via control registers, and they are programmed through the SPI or I<sup>2</sup>C serial control port. Table 3 lists the available mode control functions along with reset default conditions and associated register addresses. The register map is shown in Table 3.

**Table 3. User-Programmable Mode Control Functions**

FUNCTION RESET	DEFAULT	REGISTER	LABEL
Mode control register reset (ADC and DAC)	Normal operation	64	MRST
System reset (ADC and DAC)	Normal operation	64	SRST
ADC power-save control (ADC)	Power save	64	ADPSV
DAC power-save control (DAC)	Power save	64	DAPSV
VOOUT configuration control (DAC)	Differential	64	S/E
Digital attenuation control, 0 dB to –100 dB in 0.5-dB steps (DAC)	0 dB, no attenuation	65 and 66	AT21[7:0], AT22[7:0]
Clock select for DAC operation (DAC)	CLK2 enable	67	CSEL2
Master/slave mode for DAC audio interface (DAC)	Slave	67	M/S 2[2:0]
Interface format for DAC audio interface (DAC)	I <sup>2</sup> S	67	FMT2[1:0]
Oversampling rate control (DAC)	Low (x64/x32/x16)	68	OVER
Output phase select (DAC)	Normal	68	DREV2
Soft-mute control (DAC)	Mute disabled	68	MUT22, MUT21
Digital filter rolloff control (DAC)	Sharp rolloff	69	FLT
De-emphasis sampling rate selection (DAC)	44.1 kHz	69	DMF[1:0]
De-emphasis function control (DAC)	De-emphasis disabled	69	DMC
Zero-flag polarity control (DAC)	High for detection	69	ZREV
Zero-flag form select (DAC)	L-ch, R-ch independent	69	AZRO
Digital attenuation control, 20 dB to –100 dB in 0.5-dB steps (ADC)	0 dB, no attenuation	70 and 71	AT11[7:0], AT12[7:0]
Clock select for ADC operation (ADC)	CLK1 enable	72	CSEL1
Master/slave mode for ADC audio interface (ADC)	Slave	72	M/S1[2:0]
Interface format for ADC audio interface (ADC)	I <sup>2</sup> S	72	FMT1[1:0]
Zero-cross detection disable for digital attenuation control (ADC)	Zero-cross detection enabled	73	ZCDD
HPF bypass control (ADC)	Bypass disabled	73	BYP
Input phase select (ADC)	Normal	73	DREV1
Soft-mute control (ADC)	Mute disabled	73	MUT12, MUT11

**Table 4. Register Map**

REGISTER ADDRESS										DATA							
HEX	DEC	B15	B14	B13	B12	B11	B10	B9	B8	B7	B6	B5	B4	B3	B2	B1	B0
40h	Register 64	0	1	0	0	0	0	0	0	MRST	SRST	ADPSV	DAPSV	RSV <sup>(1)</sup>	RSV <sup>(1)</sup>	RSV <sup>(1)</sup>	S/E
41h	Register 65	0	1	0	0	0	0	0	1	AT217	AT216	AT215	AT214	AT213	AT212	AT211	AT210
42h	Register 66	0	1	0	0	0	0	1	0	AT227	AT226	AT225	AT224	AT223	AT222	AT221	AT220
43h	Register 67	0	1	0	0	0	0	1	1	CSEL2	M/S 22	M/S 21	M/S 20	RSV <sup>(1)</sup>	RSV <sup>(1)</sup>	FMT21	FMT20
44h	Register 68	0	1	0	0	0	1	0	0	RSV <sup>(1)</sup>	OVER	RSV <sup>(1)</sup>	RSV <sup>(1)</sup>	RSV <sup>(1)</sup>	DREV2	MUT22	MUT21
45h	Register 69	0	1	0	0	0	1	0	1	FLT	DMF1	DMF0	DMC	RSV <sup>(1)</sup>	RSV <sup>(1)</sup>	ZREV	AZRO
46h	Register 70	0	1	0	0	0	1	1	0	AT117	AT116	AT115	AT114	AT113	AT112	AT111	AT110
47h	Register 71	0	1	0	0	0	1	1	1	AT127	AT126	AT125	AT124	AT123	AT122	AT121	AT120
48h	Register 72	0	1	0	0	1	0	0	0	CSEL1	M/S 12	M/S 11	M/S 10	RSV <sup>(1)</sup>	RSV <sup>(1)</sup>	FMT11	FMT10
49h	Register 73	0	1	0	0	1	0	0	1	RSV <sup>(1)</sup>	RSV <sup>(1)</sup>	RSV <sup>(1)</sup>	ZCDD	BYP	DREV1	MUT12	MUT11

(1) RSV means reserved for factory use or future extension, and these bits should be set to 0 during regular operation. Do not write any values in addresses other than those listed.

**REGISTER DEFINITIONS**

	B15	B14	B13	B12	B11	B10	B9	B8	B7	B6	B5	B4	B3	B2	B1	B0
Register 64	0	1	0	0	0	0	0	0	0	MRST	SRST	ADPSV	DAPSV	RSV	RSV	S/E

**MRST: Mode Control Register Reset (ADC and DAC)**

Default value: 1

MRST = 0	Set default value
MRST = 1	Normal operation (default)

The MRST bit controls reset of the mode control registers to their default values. Pop noise may be generated. Returning the MRST bit to 1 is not required, as the MRST bit is automatically set to 1 after a mode control register reset.

**SRST: System Reset (ADC and DAC)**

Default value: 1

SRST = 0	Resynchronization
SRST = 1	Normal operation (default)

The SRST bit controls system reset, the relation between system clock and sampling clock is re-synchronized, and ADC operation and DAC operation is restarted. The mode control register is not reset and the PCM3060 does not go into power down state, but pop-noise may be generated. Returning the SRST bit to 1 is not required, as the SRST bit is automatically set to 1 after triggering a system reset.

**ADPSV: ADC Power-Save Control (ADC)**

Default value: 1

ADPSV = 0	Normal operation
ADPSV = 1	Power-save mode (default)

The ADPSV bit controls the ADC power-save mode. In power-save mode, DOUT is forced to ZERO with a fade-out sequence, the internal ADC data are reset, and the ADC goes into the power-down state. For power-save mode release, a fade-in sequence is applied on DOUT during the resume process. The serial mode control is enabled during this mode. A waiting time of more than  $2048/f_s$  is required for the proper status change by this power save control on/off. As the default state after power on is the power-save mode and DOUT is disabled (ZERO), release from the power-save mode is required for normal operation. The detailed sequence and timing for ADPSV control is shown [Figure 22](#) and [Figure 23](#).

**NOTE:**

It is recommended that changing/stopping clocks or changing the audio interface mode be performed in power-down mode in order to avoid unexpected pop/click noise and performance degradation.

**DAPSV: DAC Power-Save Control (DAC)**

Default value: 1

DAPSV = 0	Normal operation
DAPSV = 1	Power-save mode (default)

The DAPSV bit controls DAC power-save mode. In power-save mode, DAC outputs are forced to  $V_{com}$  with a fade-out sequence, the internal DAC data are reset and the DAC goes into the power-down state. For power-save mode release, a fade-in sequence is applied on the DAC outputs in resume process. The serial mode control is enabled during this mode. A waiting time of more than  $2048/f_S$  is required for the proper status change by this power-save control on/off. As the default state after power on is the power-save mode and the DAC outputs are disabled ( $V_{COM}$ ), release from the power-save mode is required for normal operation. The detailed sequence and timing for DAPSV control is shown [Figure 22](#) and [Figure 23](#).

**NOTE:**

It is recommended that changing/stopping clocks or changing the audio interface mode be performed in power-down mode in order to avoid unexpected pop/click noise and performance degradation.

**S/E: DAC Output Configuration Control (DAC)**

Default value: 0

S/E = 0	Differential (default)
S/E = 1	Single-ended

The S/E bit allows the user to select the configuration of the DAC output on the  $V_{OUTX}$  pins according to application circuit.

	B15	B14	B13	B12	B11	B10	B9	B8	B7	B6	B5	B4	B3	B2	B1	B0
Register 65	0	1	0	0	0	0	0	1	AT217	AT216	AT215	AT214	AT213	AT212	AT211	AT210
	B15	B14	B13	B12	B11	B10	B9	B8	B7	B6	B5	B4	B3	B2	B1	B0
Register 66	0	1	0	0	0	0	1	0	AT227	AT226	AT225	AT224	AT223	AT222	AT221	AT220

**AT2x[7:0]: Digital Attenuation Level Setting (DAC)**

Where x = 1 or 2, corresponding to the DAC output  $V_{OUTL}$  (x = 1) and  $V_{OUTR}$  (x = 2).

Default value: 1111 1111b

AT2x[7:0]	DECIMAL VALUE	ATTENUATION LEVEL SETTING
1111 1111b	255	0 dB, no attenuation (default)
1111 1110b	254	-0.5 dB
1111 1101b	253	-1 dB
:	:	:
1000 0001b	129	-63 dB
1000 0000b	128	-63.5 dB
0111 1111b	127	-64 dB
:	:	:
0011 1000b	56	-99.5 dB
0011 0111b	55	-100 dB
0011 0110b	54	Mute
:	:	:
0000 0000b	0	Mute

Each DAC channel ( $V_{OUTL}$  and  $V_{OUTR}$ ) has a digital attenuator function. The attenuation level may be set from 0 dB to -100 dB in 0.5-dB steps, and also may be set to infinite attenuation (mute). The attenuation level change from current value to target value is performed by incrementing or decrementing one 0.5-dB step for every  $8/f_s$  time interval. While the attenuation level change sequence is in progress, new commands for attenuation level change are not processed, but the new command overwrites the previous command in the command buffer. The last command for attenuation level change is performed after the present attenuation level change sequence is finished.

The attenuation level for each channel can be set individually using the following formula, and the foregoing table shows attenuation levels for various settings:

$$\text{Attenuation level (dB)} = 0.5 \times (\text{AT2x[7:0]}_{\text{DEC}} - 255), \text{ where } \text{AT2x[7:0]}_{\text{DEC}} = 0 \text{ through } 255 \text{ for } \text{AT2x[7:0]}_{\text{DEC}} = 0 \text{ through } 54, \text{ the level is set to infinite attenuation (mute).}$$

	B15	B14	B13	B12	B11	B10	B9	B8	B7	B6	B5	B4	B3	B2	B1	B0
Register 67	0	1	0	0	0	0	1	1	CSEL2	M/S 22	M/S 21	M/S 20	RSV	RSV	FMT21	FMT20

### CSEL2: Clock Select for DAC Operation

Default value: 0 (SCKI2, BCK2, LRCK2 enabled for DAC operation)

CSEL2 = 0	SCKI2, BCK2, LRCK2 enabled for DAC operation (default)
CSEL2 = 1	SCKI1, BCK1, LRCK1 enabled for DAC operation

The CSEL2 bit controls system clock and audio interface clocks for the DAC operation.

SCKI2, BCK2, LRCK2 are used for the DAC portion if CSEL2 = 0 (default), and SCKI1, BCK1, LRCK1 are used for DAC operation if CSEL2 = 1.

### M/S 2[2:0]: Audio Interface Mode for DAC

Default value: 000 (slave mode)

M/S 2[2:0]	Audio Interface Mode for DAC
0 0 0	Slave mode (default)
0 0 1	Master mode, 768 f <sub>S</sub>
0 1 0	Master mode, 512 f <sub>S</sub>
0 1 1	Master mode, 384 f <sub>S</sub>
1 0 0	Master mode, 256 f <sub>S</sub>
1 0 1	Master mode, 192 f <sub>S</sub>
1 1 0	Master mode, 128 f <sub>S</sub>
1 1 1	Reserved

The M/S 2[2:0] bits control the audio interface mode for the DAC.

### FMT2[1:0]: Audio Interface Format for DAC

Default value: 00 (I<sup>2</sup>S Mode)

FMT2[1:0]	Audio Interface Format for DAC
0 0	24-bit I <sup>2</sup> S format (default)
0 1	24-bit left-justified format
1 0	24-bit right-justified format
1 1	16-bit right-justified format

The FMT2[1:0] bits control the audio interface format for the DAC.

	B15	B14	B13	B12	B11	B10	B9	B8	B7	B6	B5	B4	B3	B2	B1	B0
Register 68	0	1	0	0	0	1	0	0	RSV	OVER	RSV	RSV	RSV	DREV2	MUT22	MUT21

**OVER: Oversampling Rate Control (DAC)**

Default value: 0

OVER	System clock = 512 $f_S$ or 768 $f_S$	System clock = 256 $f_S$ or 384 $f_S$	System clock = 128 $f_S$ or 192 $f_S$
OVER = 0	×64 Oversampling (default)	×32 Oversampling (default)	×16 Oversampling (default)
OVER = 1	×128 Oversampling	×64 Oversampling	×32 Oversampling

The OVER bit is used to control the oversampling rate of the delta-sigma D/A converters.

Setting OVER = 1 might improve out-of-band noise characteristics in some application environments, but it might also slightly affect baseband performance.

Writing over this bit during normal operation may generate pop noise.

**DREV2: Output Phase Select (DAC)**

Default value: 0

DREV2 = 0	Normal output (default)
DREV2 = 1	Inverted output

The DREV2 bit is used to control the phase of the analog signal outputs ( $V_{OUTL}$  and  $V_{OUTR}$ ).

**MUT2x: Soft Mute Control (DAC)**

where  $x = 1$  or  $2$ , corresponding to the DAC output  $V_{OUTL}$  ( $x = 1$ ) and  $V_{OUTR}$  ( $x = 2$ ).

Default value: 0

MUT2x = 0	Mute disabled (default)
MUT2x = 1	Mute enabled

The mute bits, MUT21 and MUT22, are used to enable or disable the soft mute function for the corresponding DAC outputs,  $V_{OUTL}$  and  $V_{OUTR}$ . The soft mute function is incorporated into the digital attenuators. When mute is disabled (MUT2x = 0), the attenuator and DAC operate normally. When mute is enabled by setting MUT2x = 1, the digital attenuator for the corresponding output is decreased from the current setting to infinite attenuation at the rate of one 0.5-dB step for every  $8/f_S$  time interval. By setting MUT2x = 0, the attenuator is increased to the previously programmed attenuation level at the rate of one 0.5-dB step for every  $8/f_S$  time interval. This provides pop-free muting of the DAC output.

	B15	B14	B13	B12	B11	B10	B9	B8	B7	B6	B5	B4	B3	B2	B1	B0
Register 69	0	1	0	0	0	1	0	1	FLT	DMF1	DMF0	DMC	RSV	RSV	ZREV	AZRO

### FLT: Digital Filter Rolloff Control (DAC)

Default value: 0

FLT = 0	Sharp rolloff (Default)
FLT = 1	Slow rolloff

The FLT bit allows the user to select the digital filter roll-off that is best suited to their application. Sharp and Slow filter roll-off selections are available. The filter responses for these selections are shown in the *Typical Performance Curves* section of this data sheet.

### DMF[1:0]: Sampling Frequency Selection for the De-Emphasis Function (DAC)

Default value: 00

DMF[1:0]	De-Emphasis Sampling Rate Selection
0 0	44.1 kHz (default)
0 1	48 kHz
1 0	32 kHz
1 1	Reserved

The DMF[1:0] bits are used to select the sampling frequency of the digital de-emphasis function when it is enabled.

### DMC: Digital De-Emphasis Function Control (DAC)

Default value: 0

DMC = 0	De-emphasis disabled (default)
DMC = 1	De-emphasis enabled

The DMC bit is used to enable or disable the digital de-emphasis function. See the plots shown in the *Typical Performance Curves* section of this data sheet for frequency characteristics.

### ZREV: Zero-Flag Polarity Select (DAC)

Default value: 0

ZREV = 0	High for zero detect (default)
ZREV = 1	Low for zero detect

The ZREV bit is used to control the polarity of zero flag pins.

### AZRO: Zero-Flag Function Select (DAC)

Default value: 0

AZRO = 0	ZEROL: L-ch ZERO detection (default)	ZEROR: R-ch ZERO detection (default)
AZRO = 1	ZEROL: L and R ZERO detection	ZEROR: L and R ZERO detection

The AZRO bit is used to select the function of zero flag pins.

	B15	B14	B13	B12	B11	B10	B9	B8	B7	B6	B5	B4	B3	B2	B1	B0
Register 70	0	1	0	0	0	1	1	0	AT117	AT116	AT115	AT114	AT113	AT112	AT111	AT110
	B15	B14	B13	B12	B11	B10	B9	B8	B7	B6	B5	B4	B3	B2	B1	B0
Register 71	0	1	0	0	0	1	1	1	AT127	AT126	AT125	AT124	AT123	AT122	AT121	AT120

**AT1x[7:0]: Digital Attenuation Level Setting (ADC)**

where x = 1 or 2, corresponding to the ADC output L-ch part of DOUT (x = 1) or R-ch part of DOUT (x = 2).

Default value: 1101 0111b

AT1x[7:0]	DECIMAL VALUE	ATTENUATION LEVEL SETTING
1111 1111b	255	20 dB
1111 1110b	254	19.5 dB
1111 1101b	253	19 dB
:	:	:
1101 1000b	216	0.5 dB
1101 0111b	215	0 dB, no attenuation (default)
1101 0110b	214	–0.5 dB
:	:	:
0001 0000b	16	–99.5 dB
0000 1111b	15	–100 dB
0000 1110b	14	Mute
:	:	:
0000 0000b	0	Mute

Each ADC channel has a digital attenuator function with 20-dB gain. The attenuation level may be set from 20 dB to –100 dB in 0.5-dB steps, and also may be set to infinite attenuation (mute). The attenuation level change from the current value to the target value is performed by incrementing or decrementing one by 0.5-dB step at the timing of zero-cross detection on the input signal which is sampled for every  $1/f_S$  time interval, or for every  $8/f_S$  time interval if the zero-cross detection mode is disabled by ZCDD setting. If a zero-crossing is not detected for  $512/f_S$ , actual level change is done for every  $1/f_S$  time interval until a zero-crossing is detected again. While the attenuation level change sequence is in progress, new commands for attenuation level change are not processed, but the new command overwrites the previous command in the command buffer. The last command for attenuation level change is performed after the present attenuation level change sequence is finished.

The attenuation level for each channel can be set individually using the following formula, and the above table shows attenuation levels for various settings:

Attenuation level (dB) =  $0.5 \times (AT1x[7:0]_{DEC} - 215)$ , where  $AT1x[7:0]_{DEC} = 0$  through 255 for  $AT1x[7:0]_{DEC} = 0$  through 14, the level is set to infinite attenuation (mute).

	B15	B14	B13	B12	B11	B10	B9	B8	B7	B6	B5	B4	B3	B2	B1	B0	
Register 72	0	1	0	0	1	0	0	0	0	CSEL1	M/S 12	M/S 11	M/S 10	RSV	RSV	FMT11	FMT10

**CSEL1: Clock Select for ADC Operation**

Default value: 0 (SCK11, BCK1, LRCK1 enabled for ADC operation)

CSEL1 = 0	SCK11, BCK1, LRCK1 enabled for ADC operation (default)
CSEL1 = 1	SCKI2, BCK2, LRCK2 enabled for ADC operation

The CSEL1 bit controls the system clock and audio interface clocks for the ADC operation.

SCK11, BCK1, LRCK1 are used for ADC portion if CSEL1 = 0 (default), and SCKI2, BCK2, LRCK2 are used for ADC portion if CSEL1 = 1.

**M/S 1[2:0]: Audio Interface Mode for ADC**

Default value: 000 (slave mode)

M/S 1[2:0]	Audio Interface Mode for ADC
0 0 0	Slave mode (default)
0 0 1	Master mode, 768 f <sub>S</sub>
0 1 0	Master mode, 512 f <sub>S</sub>
0 1 1	Master mode, 384 f <sub>S</sub>
1 0 0	Master mode, 256 f <sub>S</sub>
1 0 1	Reserved
1 1 0	Reserved
1 1 1	Reserved

The M/S 1[2:0] bits control the audio interface mode for the ADC.

**FMT1[1:0]: Audio Interface Format for ADC**

Default value: 00 (I<sup>2</sup>S mode)

FMT1[1:0]	Audio Interface Format for ADC
0 0	24-bit I <sup>2</sup> S format (default)
0 1	24-bit left-justified format
1 0	24-bit right-justified format
1 1	16-bit right-justified format

The FMT1[1:0] bits control the audio interface mode for ADC.

	B15	B14	B13	B12	B11	B10	B9	B8	B7	B6	B5	B4	B3	B2	B1	B0
Register 73	0	1	0	0	1	0	0	1	RSV	RSV	RSV	ZCDD	BYP	DREV1	MUT12	MUT11

**ZCDD: Zero-Cross Detection Disable for Digital Attenuation (ADC)**

Default value: 0

ZCDD = 0	Zero-cross detection enabled (default)
ZCDD = 1	Zero-cross detection disabled

The ZCDD bit controls the zero-cross detect function for digital attenuation and mute. When zero-cross detection is enabled, the actual level change for digital attenuation and mute is done at the timing of zero-cross detection on the input signal which is sampled for every  $1/f_S$  time interval. If zero-crossing is not detected for  $512/f_S$ , the actual level change is done for every  $1/f_S$  time interval until a zero-crossing is detected again as timeout control for no zero-crossing input signal. When zero-cross detection is disabled, the actual level change is done at the timing of  $8/f_S$  time interval.

**BYP: HPF Bypass Control (ADC)**

Default value: 0

BYP = 0	Normal output, HPF enabled (default)
BYP = 1	Bypassed output, HPF disabled

The BYP bit controls the HPF function; the dc component of the input signal and the internal dc offset are converted in bypass mode.

**DREV1: Input Phase Select (ADC)**

Default value: 0

DREV1 = 0	Normal input (default)
DREV1 = 1	Inverted input

The DREV1 bit is used to control the phase of analog signal inputs ( $V_{INL}$  and  $V_{INR}$ ).

**MUT1x: Soft Mute Control (ADC)**

where  $x = 1$  or  $2$ , corresponding to the ADC output L-ch part of DOUT ( $x = 1$ ) and R-ch part of DOUT ( $x = 2$ ).

Default value: 0

MUT1x = 0	Mute disabled (default)
MUT1x = 1	Mute enabled

The mute bits, MUT11 and MUT12, are used to enable or disable the soft mute function for the corresponding ADC outputs, DOUT. The soft mute function is incorporated into the digital attenuators. When mute is disabled ( $MUT1x = 0$ ), the attenuator and ADC operate normally. When mute is enabled by setting  $MUT1x = 1$ , the digital attenuator for the corresponding output is decreased from the current setting to infinite attenuation in 0.5 dB step at the timing of zero-cross detection on the input signal which is sampled for every  $1/f_S$  time interval, or for every  $8/f_S$  time interval if zero-cross detection mode is disabled by ZCDD setting. If a zero-crossing is not detected for  $512/f_S$ , actual level change is done for every  $1/f_S$  time interval until zero-crossing is detected again. By setting  $MUT1x = 0$ , the attenuator is increased to the previously programmed attenuation level in 0.5 dB step in the same manner as for decreasing. This provides pop-free muting for the ADC input.

## TYPICAL CIRCUIT CONNECTION

Figure 33 illustrates typical circuit connection.

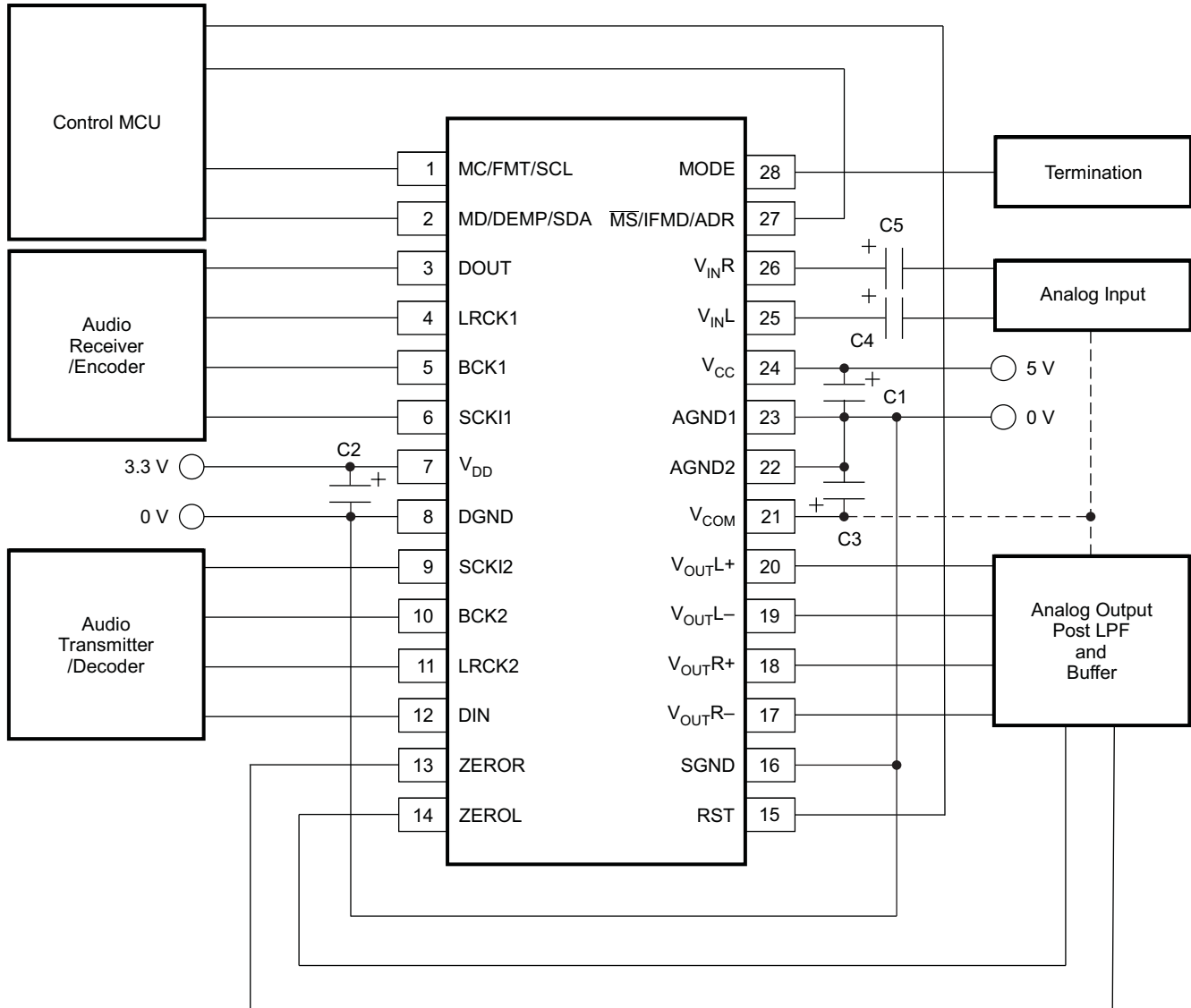

Note: C1, C2: 0.1- $\mu$ F ceramic capacitor and 10- $\mu$ F electrolytic capacitor, depend on power supply.

C3: 0.1- $\mu$ F ceramic capacitor and 10- $\mu$ F electrolytic capacitor is recommended.

C4, C5: 4.7- $\mu$ F electrolytic capacitor is recommended for 3-Hz cutoff frequency.

The termination for mode/configuration control.

Either one of following circuits has to be applied according to necessary mode/configuration.

Resistor value must be 220 k $\Omega$ ,  $\pm$ 5 % tolerance.

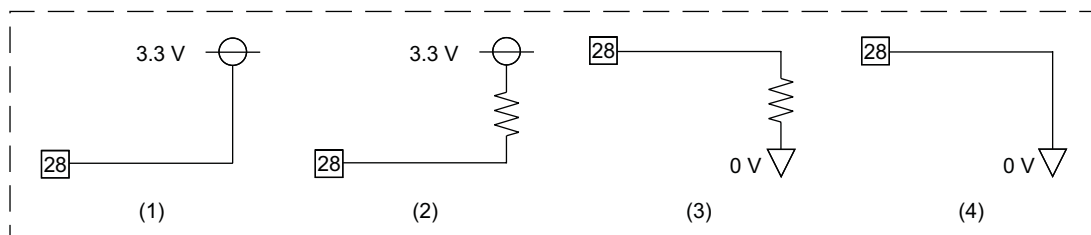

S0257-01

Figure 33. Typical Application Diagram

### Application Examples for Analog Input and Output

a) Example of  $V_{COM}$ -biased buffering for 2-Vrms input with overvoltage protection.

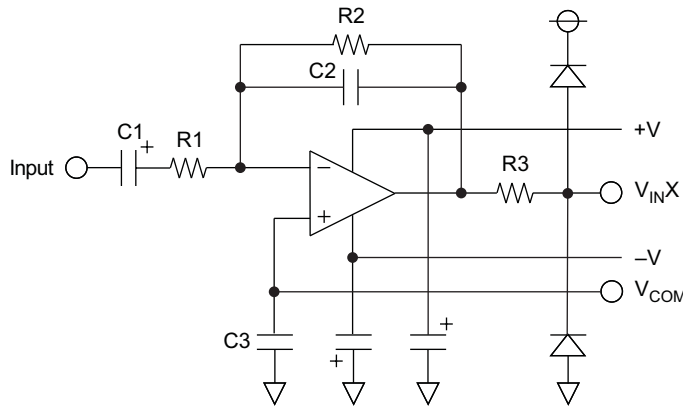

Example of C, R values with gain (G) and corner frequency ( $f_C$ )

- R1: 20 k $\Omega$
- R2: 10 k $\Omega$
- R3: 1 k $\Omega$
- C1: 10  $\mu$ F
- C2: 330 pF
- C3: 0.1  $\mu$ F
- G: 0.5
- $f_C$ : 48 kHz

b) Example of capless differential to single-ended converter with LPF and gain for 2-Vrms standard output.

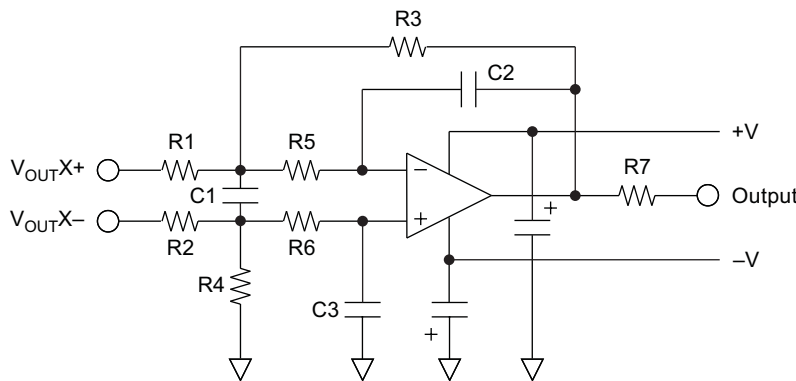

Example of C, R values with gain (G) and corner frequency ( $f_C$ )

- R1, R2: 10 k $\Omega$
- R3, R4: 7.5 k $\Omega$
- R5, R6: 820  $\Omega$
- R7: 100  $\Omega$
- C1: 1500 pF
- C2, C3: 470 pF
- G: 0.75 (Differential to S/E)
- $f_C$ : 54 kHz

c) Example of  $V_{COM}$ -biased single-supply single-ended application with LPF and MUTE control for 1-Vrms output.

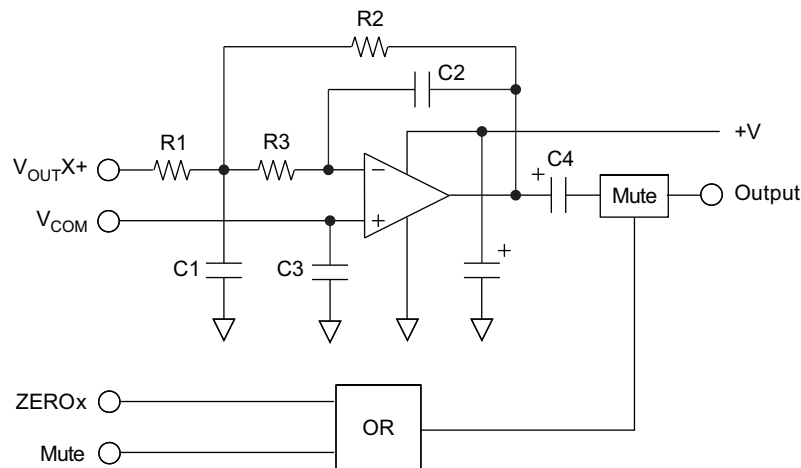

Example of C, R values with gain (G) and corner frequency ( $f_C$ )

- R1: 10 k $\Omega$
- R2: 7.5 k $\Omega$
- R3: 750  $\Omega$
- C1: 3300 pF
- C2: 470 pF
- C3: 0.1  $\mu$ F
- C4: 10  $\mu$ F
- G: 0.75
- $f_C$ : 54 kHz

S0258-01

Figure 34. Application Examples for Analog Input and Output

## DESIGN AND LAYOUT CONSIDERATIONS IN APPLICATION

### Power Supply Pins ( $V_{CC}$ , $V_{DD}$ )

The digital and analog power supply lines to the PCM3060 should be bypassed to the corresponding ground pins with 0.1- $\mu$ F ceramic and 10- $\mu$ F electrolytic capacitors as close to the pins as possible to maximize the dynamic performance of the ADC and DAC.

Although the PCM3060 has two power lines to maximize the potential of dynamic performance, using one common source, 5-V power supply for  $V_{CC}$  and a 3.3-V power supply for  $V_{DD}$  which is generated from the 5-V power supply for  $V_{CC}$ , is recommended to avoid unexpected problems, such as latch-up, from incorrect power supply sequencing.

### Grounding (AGND1, AGND2, SGND, DGND)

To maximize the dynamic performance of the PCM3060, the analog and digital grounds are not connected internally. These points should have very low impedance to avoid digital noise and signal components feeding back into the analog ground. So, they should be connected directly to each other under the parts to reduce the potential of noise problems.

### $V_{INL}$ , $V_{INR}$ Pins

A 4.7- $\mu$ F electrolytic capacitor is recommended as the ac coupling capacitor, which gives a 3-Hz cutoff frequency. If higher full-scale input voltage is required, it can be adjusted by adding only one series resistor to the  $V_{INX}$  pins, although a small gain error is added due to variations of absolute input resistance of the PCM3060. For example, adding 9.1 k $\Omega$  gives 2 V<sub>rms</sub> full-scale with about 10% gain error.

### $V_{COM}$ Pin

Ceramic 0.1- $\mu$ F and electrolytic 10- $\mu$ F capacitors are recommended between  $V_{COM}$  and AGND to ensure low source impedance of the ADC and DAC references. These capacitors should be located as close as possible to the  $V_{COM}$  pins to reduce dynamic errors on ADC and DAC references.

### $V_{OUTL+}$ , $V_{OUTL-}$ , $V_{OUTR+}$ , $V_{OUTR-}$ Pins

The differential to single-ended buffer with post LPF can be directly (without capacitor) connected to these output pins, thereby minimizing the use of coupling capacitors for the 2-V<sub>rms</sub> outputs. The output pins in single-ended mode are assigned to  $V_{OUTL+}$  and  $V_{OUTR+}$ ; in single-ended mode, the  $V_{OUTL-}$  and  $V_{OUTR-}$  pins must be open.

### MODE Pin

This pin is a logic input with quad-state input capability.

The pin is connected to  $V_{DD}$  for High, to DGND for Low, and pulled up or pulled down through an external resistor and for the two mid-states in order to distinguish the four input states. The pullup or pulldown resistor must be 220 k $\Omega$ ,  $\pm$ 5% tolerance.

### System Clocks

The quality of SCK11/2 may influence dynamic performance, as the PCM3060 (both ADC and DAC) operates based on SCK11/2. Therefore, it may be required to consider the jitter, duty, rise and fall time, etc. of the system clocks.

The PCM3060 supports asynchronous operation between the ADC and DAC. Therefore, there is no restriction on the relationship between SCK11 and SCK12 for digital operation, but it is strongly recommended to use a common clock if the application does not require different base clock frequencies, like 44.1 kHz and 48 kHz.

### Audio Interface Clocks

In slave mode, PCM3060 does not require specific timing relationship between BCK1/LRCK1 and SCK11, BCK2/LRCK2 and SCK12, but there is a possibility of performance degradation with a certain timing relationship between them. In that case, specific timing-relationship control might solve this performance degradation.

In master mode, there is a possibility of performance degradation due to heavy loads on BCK1/LRCK1, BCK2/LRCK2 and DOUT. It is recommended to load these pins as lightly as possible.

### External Mute Control

For power-down ON/OFF control without the pop noise which is generated by a dc level change on the DAC output, the external mute control is generally required. Use of the following control sequence is recommended: external mute ON, codec power down ON, SCK11/SCK12 stop and resume if necessary, codec power down OFF, and external mute OFF.

## REVISION HISTORY

Changes from Original (March 2007) to Revision A	Page
<ul style="list-style-type: none"> <li>Changed <a href="#">Figure 34</a>(a), (b), and (c). Updated the Example of C, R values. ....</li> </ul>	40
Changes from Revision A (February 2008) to Revision B	Page
<ul style="list-style-type: none"> <li>Changed Supply Current - <math>f_s = 48</math> kHz/ADC, <math>f_s = 48</math> kHz/DAC max value From: 30 mA To: 36 mA .....</li> <li>Changed Power dissipation - <math>f_s = 48</math> kHz/ADC, <math>f_s = 48</math> kHz/DAC max value From: 190 mW To: 220 mW .....</li> </ul>	6

**PACKAGING INFORMATION**

Orderable Device	Status (1)	Package Type	Package Drawing	Pins	Package Qty	Eco Plan (2)	Lead finish/ Ball material (6)	MSL Peak Temp (3)	Op Temp (°C)	Device Marking (4/5)	Samples
PCM3060PW	ACTIVE	TSSOP	PW	28	50	RoHS & Green	NIPDAU	Level-2-260C-1 YEAR	-25 to 85	PCM3060	<a href="#">Samples</a>
PCM3060PWR	ACTIVE	TSSOP	PW	28	2000	RoHS & Green	NIPDAU	Level-2-260C-1 YEAR	-25 to 85	PCM3060	<a href="#">Samples</a>
PCM3060PWRG4	ACTIVE	TSSOP	PW	28	2000	RoHS & Green	NIPDAU	Level-2-260C-1 YEAR	-25 to 85	PCM3060	<a href="#">Samples</a>

(1) The marketing status values are defined as follows:

**ACTIVE:** Product device recommended for new designs.

**LIFEBUY:** TI has announced that the device will be discontinued, and a lifetime-buy period is in effect.

**NRND:** Not recommended for new designs. Device is in production to support existing customers, but TI does not recommend using this part in a new design.

**PREVIEW:** Device has been announced but is not in production. Samples may or may not be available.

**OBSOLETE:** TI has discontinued the production of the device.

(2) **RoHS:** TI defines "RoHS" to mean semiconductor products that are compliant with the current EU RoHS requirements for all 10 RoHS substances, including the requirement that RoHS substance do not exceed 0.1% by weight in homogeneous materials. Where designed to be soldered at high temperatures, "RoHS" products are suitable for use in specified lead-free processes. TI may reference these types of products as "Pb-Free".

**RoHS Exempt:** TI defines "RoHS Exempt" to mean products that contain lead but are compliant with EU RoHS pursuant to a specific EU RoHS exemption.

**Green:** TI defines "Green" to mean the content of Chlorine (Cl) and Bromine (Br) based flame retardants meet JS709B low halogen requirements of <=1000ppm threshold. Antimony trioxide based flame retardants must also meet the <=1000ppm threshold requirement.

(3) MSL, Peak Temp. - The Moisture Sensitivity Level rating according to the JEDEC industry standard classifications, and peak solder temperature.

(4) There may be additional marking, which relates to the logo, the lot trace code information, or the environmental category on the device.

(5) Multiple Device Markings will be inside parentheses. Only one Device Marking contained in parentheses and separated by a "~" will appear on a device. If a line is indented then it is a continuation of the previous line and the two combined represent the entire Device Marking for that device.

(6) Lead finish/Ball material - Orderable Devices may have multiple material finish options. Finish options are separated by a vertical ruled line. Lead finish/Ball material values may wrap to two lines if the finish value exceeds the maximum column width.

**Important Information and Disclaimer:**The information provided on this page represents TI's knowledge and belief as of the date that it is provided. TI bases its knowledge and belief on information provided by third parties, and makes no representation or warranty as to the accuracy of such information. Efforts are underway to better integrate information from third parties. TI has taken and continues to take reasonable steps to provide representative and accurate information but may not have conducted destructive testing or chemical analysis on incoming materials and chemicals. TI and TI suppliers consider certain information to be proprietary, and thus CAS numbers and other limited information may not be available for release.

In no event shall TI's liability arising out of such information exceed the total purchase price of the TI part(s) at issue in this document sold by TI to Customer on an annual basis.

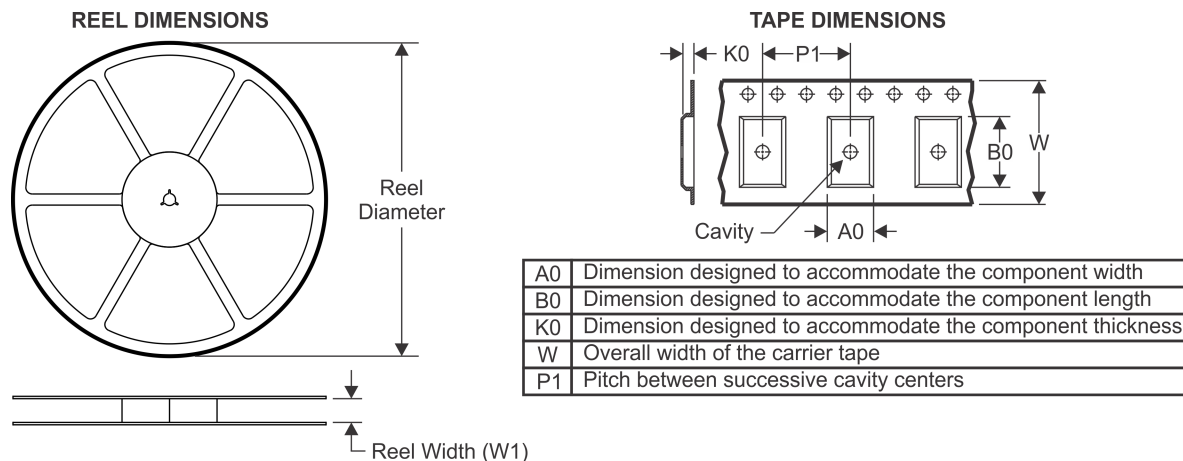
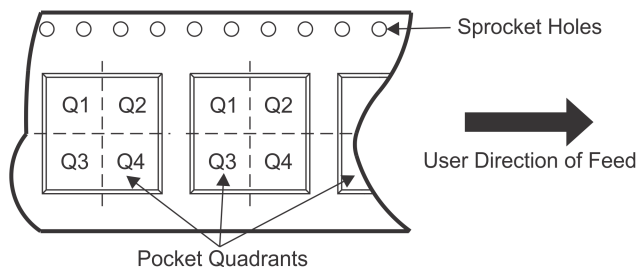
**TAPE AND REEL INFORMATION**

**QUADRANT ASSIGNMENTS FOR PIN 1 ORIENTATION IN TAPE**

\*All dimensions are nominal

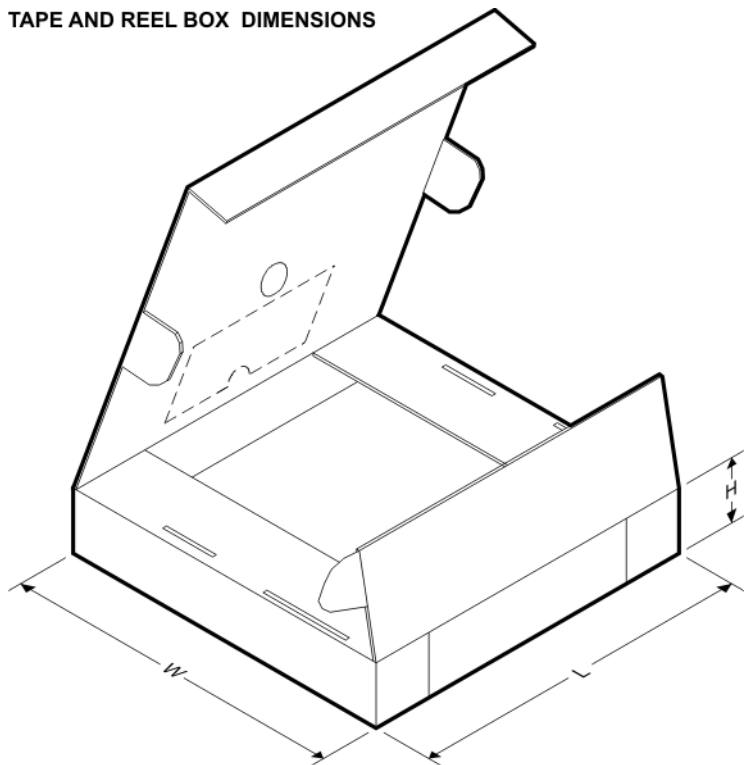
Device	Package Type	Package Drawing	Pins	SPQ	Reel Diameter (mm)	Reel Width W1 (mm)	A0 (mm)	B0 (mm)	K0 (mm)	P1 (mm)	W (mm)	Pin1 Quadrant
PCM3060PWR	TSSOP	PW	28	2000	330.0	16.4	6.9	10.2	1.8	12.0	16.0	Q1

**TAPE AND REEL BOX DIMENSIONS**

\*All dimensions are nominal

Device	Package Type	Package Drawing	Pins	SPQ	Length (mm)	Width (mm)	Height (mm)
PCM3060PWR	TSSOP	PW	28	2000	853.0	449.0	35.0

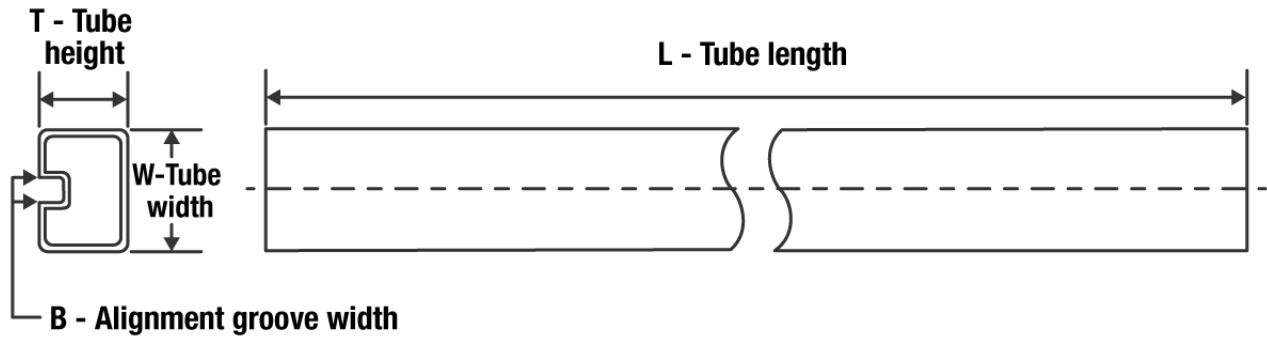
**TUBE**

\*All dimensions are nominal

Device	Package Name	Package Type	Pins	SPQ	L (mm)	W (mm)	T (μm)	B (mm)
PCM3060PW	PW	TSSOP	28	50	530	10.2	3600	3.5

PW (R-PDSO-G28)

PLASTIC SMALL OUTLINE

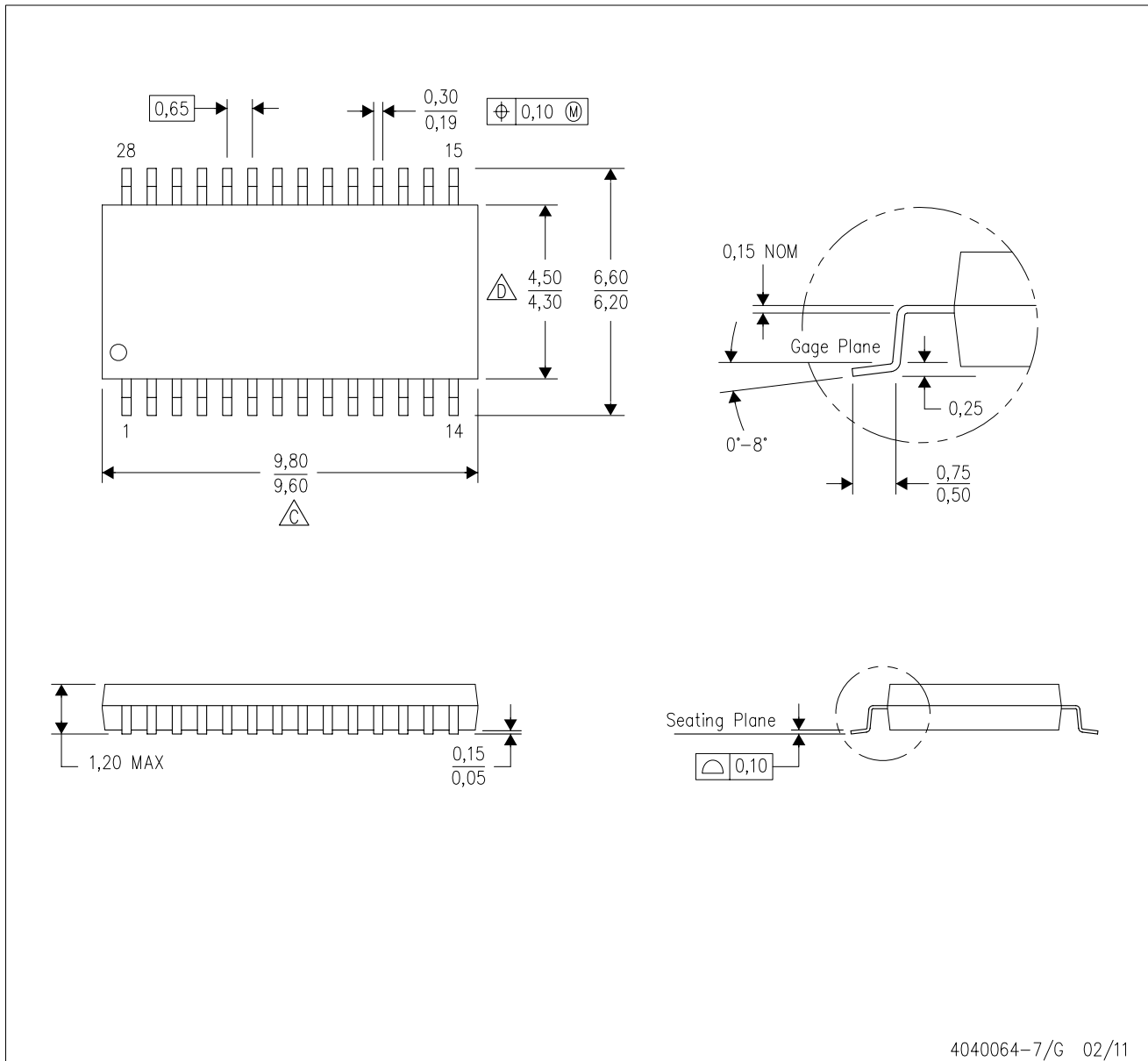

4040064-7/G 02/11

- NOTES:
- A. All linear dimensions are in millimeters. Dimensioning and tolerancing per ASME Y14.5M-1994.
  - B. This drawing is subject to change without notice.
  - C. Body length does not include mold flash, protrusions, or gate burrs. Mold flash, protrusions, or gate burrs shall not exceed 0,15 each side.
  - D. Body width does not include interlead flash. Interlead flash shall not exceed 0,25 each side.
  - E. Falls within JEDEC MO-153

PW (R-PDSO-G28)

PLASTIC SMALL OUTLINE

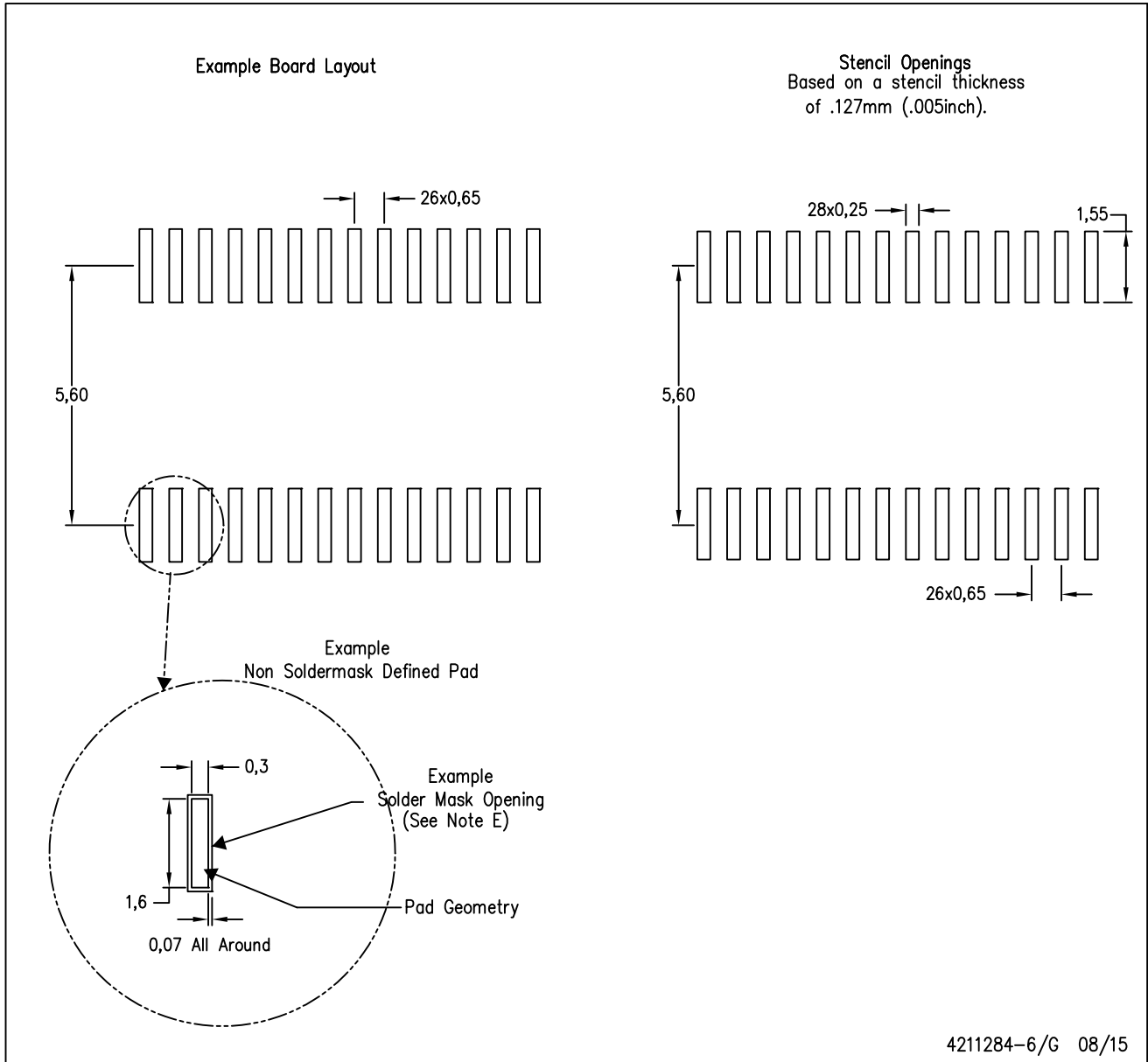

- NOTES:
- A. All linear dimensions are in millimeters.
  - B. This drawing is subject to change without notice.
  - C. Publication IPC-7351 is recommended for alternate design.
  - D. Laser cutting apertures with trapezoidal walls and also rounding corners will offer better paste release. Customers should contact their board assembly site for stencil design recommendations. Refer to IPC-7525 for other stencil recommendations.
  - E. Customers should contact their board fabrication site for solder mask tolerances between and around signal pads.

## IMPORTANT NOTICE AND DISCLAIMER

TI PROVIDES TECHNICAL AND RELIABILITY DATA (INCLUDING DATA SHEETS), DESIGN RESOURCES (INCLUDING REFERENCE DESIGNS), APPLICATION OR OTHER DESIGN ADVICE, WEB TOOLS, SAFETY INFORMATION, AND OTHER RESOURCES "AS IS" AND WITH ALL FAULTS, AND DISCLAIMS ALL WARRANTIES, EXPRESS AND IMPLIED, INCLUDING WITHOUT LIMITATION ANY IMPLIED WARRANTIES OF MERCHANTABILITY, FITNESS FOR A PARTICULAR PURPOSE OR NON-INFRINGEMENT OF THIRD PARTY INTELLECTUAL PROPERTY RIGHTS.

These resources are intended for skilled developers designing with TI products. You are solely responsible for (1) selecting the appropriate TI products for your application, (2) designing, validating and testing your application, and (3) ensuring your application meets applicable standards, and any other safety, security, regulatory or other requirements.

These resources are subject to change without notice. TI grants you permission to use these resources only for development of an application that uses the TI products described in the resource. Other reproduction and display of these resources is prohibited. No license is granted to any other TI intellectual property right or to any third party intellectual property right. TI disclaims responsibility for, and you will fully indemnify TI and its representatives against, any claims, damages, costs, losses, and liabilities arising out of your use of these resources.

TI's products are provided subject to [TI's Terms of Sale](#) or other applicable terms available either on [ti.com](#) or provided in conjunction with such TI products. TI's provision of these resources does not expand or otherwise alter TI's applicable warranties or warranty disclaimers for TI products.

TI objects to and rejects any additional or different terms you may have proposed.

Mailing Address: Texas Instruments, Post Office Box 655303, Dallas, Texas 75265  
Copyright © 2022, Texas Instruments Incorporated