

符合汽车标准的 CD74HCU04-Q1 六路非缓冲逆变器

1 特性

- 符合 AEC-Q100 车规认证：
 - 器件温度等级 1: -40°C 至 $+125^{\circ}\text{C}$, T_A
- 符合汽车类应用要求
- 非缓冲逻辑
- 正负输入钳位二极管
- 宽工作电压范围: 2V 至 6V
- 与 LSTTL 逻辑 IC 相比, 可显著降低功耗

2 应用

- RC 振荡器电路
- 晶体振荡器电路

3 说明

CD74HCU04-Q1 器件包含六个独立的高速 CMOS 非缓冲逆变器。每个逆变器以正逻辑执行布尔函数 $Y = \bar{A}$ 。

器件信息⁽¹⁾

器件型号	封装	封装尺寸 (标称值)
CD74HCU04QPWRQ1	TSSOP (14)	5.00mm x 4.40mm

(1) 如需了解所有可用封装, 请参阅数据表末尾的可订购产品附录。

CD74HCU04-Q1 的功能引脚

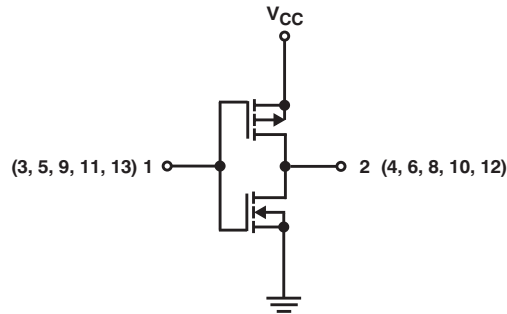

目录

1	特性	1	8.3	Feature Description	8
2	应用	1	8.4	Device Functional Modes	9
3	说明	1	9	Application and Implementation	10
4	修订历史记录	2	9.1	Application Information	10
5	Pin Configuration and Functions	3	9.2	Typical Application	10
6	Specifications	3	10	Power Supply Recommendations	13
6.1	Absolute Maximum Ratings	3	11	Layout	13
6.2	ESD Ratings	4	11.1	Layout Guidelines	13
6.3	Recommended Operating Conditions	4	11.2	Layout Example	13
6.4	Thermal Information	4	12	器件和文档支持	14
6.5	Electrical Characteristics	5	12.1	文档支持	14
6.6	Switching Characteristics	5	12.2	相关链接	14
6.7	Operating Characteristics	5	12.3	社区资源	14
6.8	Typical Characteristics	6	12.4	商标	14
7	Parameter Measurement Information	7	12.5	静电放电警告	14
8	Detailed Description	8	12.6	Glossary	14
8.1	Overview	8	13	机械、封装和可订购信息	14
8.2	Functional Block Diagram	8			

4 修订历史记录

注：之前版本的页码可能与当前版本有所不同。

Changes from Revision (June 2010) to Revision A	Page
• 更新至全新数据表标准	1
• Thermal impedance $R_{\theta JA}$ updated from 112.6 to 121.1 °C/W	4

5 Pin Configuration and Functions

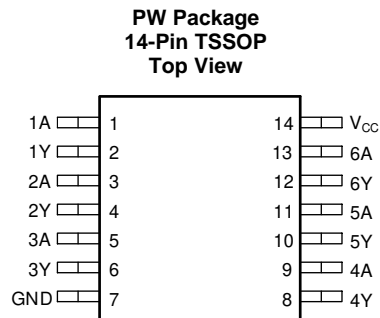

Pin Functions

PIN		I/O	DESCRIPTION
NAME	NO.		
1A	1	Input	Channel 1, Input A
1Y	2	Output	Channel 1, Output Y
2A	3	Input	Channel 2, Input A
2Y	4	Output	Channel 2, Output Y
3A	5	Input	Channel 3, Input A
3Y	6	Output	Channel 3, Output Y
GND	7	—	Ground
4Y	8	Output	Channel 4, Output Y
4A	9	Input	Channel 4, Input A
5Y	10	Output	Channel 5, Output Y
5A	11	Input	Channel 5, Input A
6Y	12	Output	Channel 6, Output Y
6A	13	Input	Channel 6, Input A
V _{CC}	14	—	Positive Supply

6 Specifications

6.1 Absolute Maximum Ratings

over operating free-air temperature range (unless otherwise noted)⁽¹⁾

		MIN	MAX	UNIT
V _{CC}	Supply voltage	−0.5	7	V
I _{IK}	Input clamp current ⁽²⁾		±20	mA
		V _I < 0 or V _I > V _{CC}		
I _{OK}	Output clamp current ⁽²⁾		±20	mA
		V _O < 0 or V _O > V _{CC}		
I _O	Continuous output current		±25	mA
		V _O = 0 to V _{CC}		
	Continuous current through V _{CC} or GND		±50	mA
T _J	Junction temperature ⁽³⁾		150	°C
T _{stg}	Storage temperature	−65	150	°C

(1) Stresses beyond those listed under *Absolute Maximum Rating* may cause permanent damage to the device. These are stress ratings only, which do not imply functional operation of the device at these or any other conditions beyond those indicated under *Recommended Operating Condition*. Exposure to absolute-maximum-rated conditions for extended periods may affect device reliability.

(2) The input and output voltage ratings may be exceeded if the input and output current ratings are observed.

(3) Guaranteed by design.

6.2 ESD Ratings

			VALUE	UNIT
$V_{(ESD)}$	Electrostatic discharge	Human body model (HBM), per AEC Q100-002 ⁽¹⁾ HBM ESD Classification Level 2	±2000	V
		Charged device model (CDM), per AEC Q100-011 CDM ESD Classification Level C6	±1000	

(1) AEC Q100-002 indicate that HBM stressing shall be in accordance with the ANSI/ESDA/JEDEC JS-001 specification.

6.3 Recommended Operating Conditions

over operating free-air temperature range (unless otherwise noted)

		MIN	NOM	MAX	UNIT
V_{CC}	Supply voltage	2		6	V
V_I	Input voltage	0		V_{CC}	V
V_O	Output voltage	0		V_{CC}	V
T_A	Operating free-air temperature	–40		125	°C

6.4 Thermal Information

THERMAL METRIC		CD74HCU04-Q1	UNIT
		PW (TSSOP)	
		14 PINS	
$R_{\theta JA}$	Junction-to-ambient thermal resistance	121.1	°C/W
$R_{\theta JC(top)}$	Junction-to-case (top) thermal resistance	50.2	°C/W
$R_{\theta JB}$	Junction-to-board thermal resistance	64.2	°C/W
Ψ_{JT}	Junction-to-top characterization parameter	6.1	°C/W
Ψ_{JB}	Junction-to-board characterization parameter	63.6	°C/W
$R_{\theta JC(bot)}$	Junction-to-case (bottom) thermal resistance	N/A	°C/W

6.5 Electrical Characteristics

over operating free-air temperature range; typical values measured at $T_A = 25^\circ\text{C}$ (unless otherwise noted).

PARAMETER		TEST CONDITIONS		V_{CC}	Operating free-air temperature (T_A)						UNIT	
					25°C			-40°C to 125°C				
					MIN	TYP	MAX	MIN	TYP	MAX		
V_{IH}	High level input voltage			2 V	1.7			1.7			V	
				4.5 V	3.6			3.6				
				6 V	4.8			4.8				
V_{IL}	Low level input voltage			2 V				0.3			V	
				4.5 V				0.8				
				6 V				1.1				
V_{OH}	High-level output voltage	$V_I = V_{IH}$ or V_{IL}	$I_{OH} = -20\ \mu\text{A}$	2 V	1.8			1.8			V	
				4.5 V	4.4			4.4				
				6 V	5.5			5.5				
				4.5 V	3.98			3.7				
				6 V	5.48			5.2				
V_{OL}	Low-level output voltage	$V_I = V_{IH}$ or V_{IL}	$I_{OL} = 20\ \mu\text{A}$	2 V				0.2			V	
				4.5 V				0.5				
				6 V				0.5				
				4.5 V	0.26			0.4				
				6 V	0.26			0.4				
I_i	Input leakage current	$V_I = V_{CC}$ or 0		6 V				± 0.1			μA	
I_{CC}	Supply current	$V_I = V_{CC}$ or 0	$I_O = 0$	6 V				2			40	μA
C_i	Input capacitance			2 V to 6 V	7						pF	

6.6 Switching Characteristics

over operating free-air temperature range (unless otherwise noted), $C_L = 50\ \text{pF}$

PARAMETER		FROM	TO	V_{CC}	Operating free-air temperature (T_A)						UNIT
					25°C			-40°C to 125°C			
					MIN	TYP	MAX	MIN	TYP	MAX	
t_{pd}	Propagation delay	A	Y	2 V	70			105			ns
				4.5 V	14			21			
				6 V	12			18			
t_t	Transition-time		Y	2 V	75			110			ns
				4.5 V	15			22			
				6 V	13			19			

6.7 Operating Characteristics

over operating free-air temperature range; typical values measured at $T_A = 25^\circ\text{C}$ (unless otherwise noted).

PARAMETER		TEST CONDITIONS	MIN	TYP	MAX	UNIT
C_{pd}	Power dissipation capacitance per gate	$V_{CC} = 5\ \text{V}$, No load		14		pF

6.8 Typical Characteristics

$T_A = 25^\circ\text{C}$



图 1. Typical Inverter Supply Current as a Function of Input Voltage



图 2. Input Capacitance as a Function of Input Voltage

7 Parameter Measurement Information

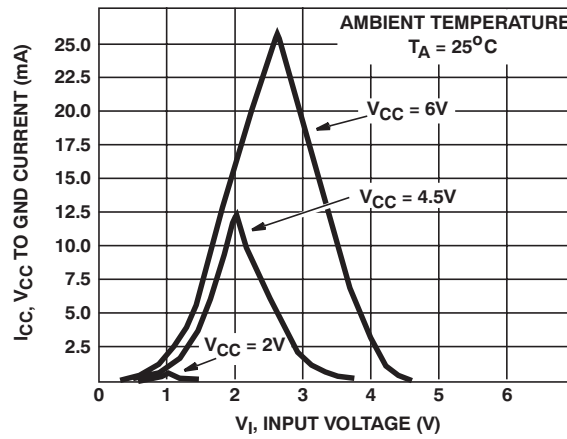
- Phase relationships between waveforms were chosen arbitrarily. All input pulses are supplied by generators having the following characteristics: $PRR \leq 1 \text{ MHz}$, $Z_O = 50 \Omega$, $t_t < 6 \text{ ns}$.
- The outputs are measured one at a time, with one input transition per measurement.

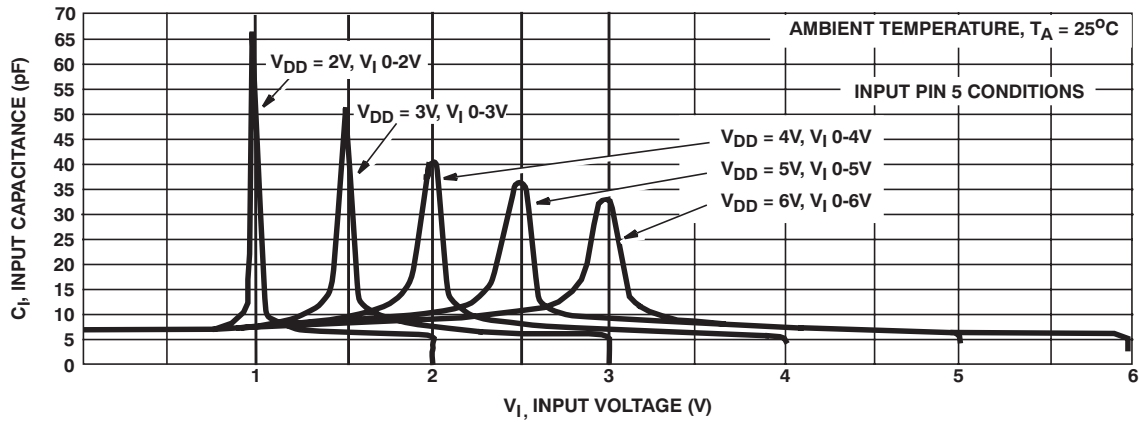
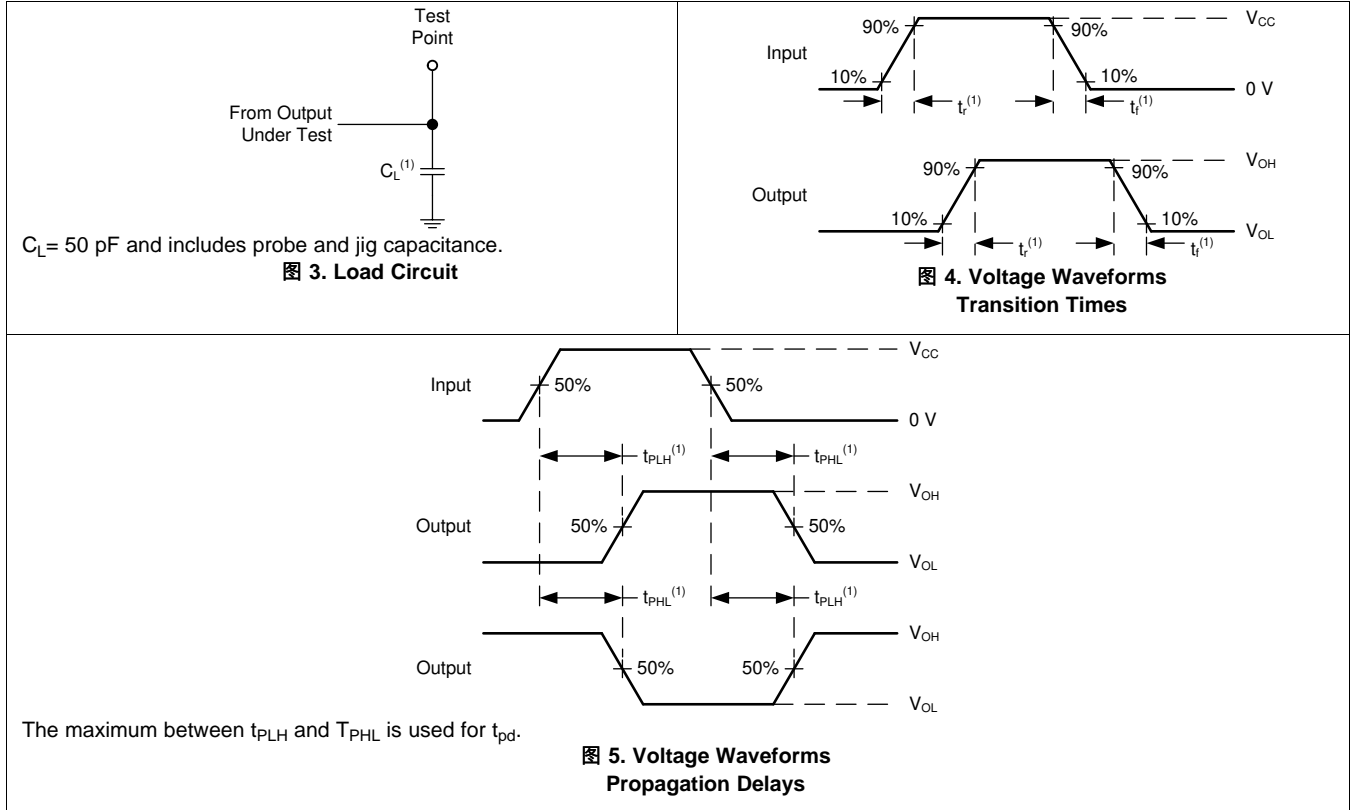

8 Detailed Description

8.1 Overview

The CD74HCU04-Q1 device contains six independent high-speed CMOS unbuffered inverters.

8.2 Functional Block Diagram

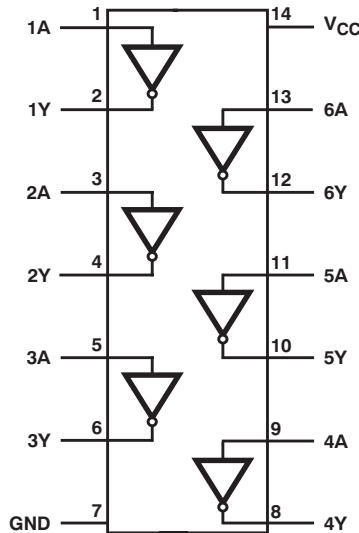

8.3 Feature Description

8.3.1 Unbuffered CMOS Logic

Unlike most CMOS logic devices, this device does not include input or output buffers. The input, logic function, and output are all completed by the same set of complementary MOSFETs, as shown in [图 6](#).



图 6. Logic schematic diagram

Each channel of the CD74HCU04-Q1 can drive a load with a total capacitance less than or equal to 50 pF connected to a high-impedance CMOS input while still meeting all of the datasheet specifications. Larger capacitive loads can be applied, however it is not recommended to exceed 70 pF. If larger capacitive loads are required, it is recommended to add a series resistor between the output and the capacitor to limit output current to the values given in the [Absolute Maximum Ratings](#).

Feature Description (接下页)

8.3.2 Clamp Diode Structure

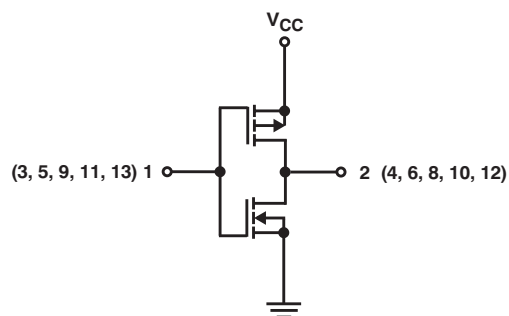
The inputs and outputs to this device have both positive and negative clamping diodes as depicted in 图 7.

CAUTION

Voltages beyond the values specified in the [Absolute Maximum Ratings](#) table can cause damage to the device. The recommended input and output voltage ratings may be exceeded if the input and output clamp-current ratings are observed.



图 7. Electrical Placement of Clamping Diodes for Each Input and Output

8.4 Device Functional Modes

表 1. Function Table

INPUT	OUTPUT
A	Y
L	H
H	L

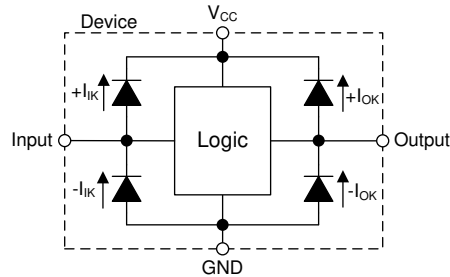
9 Application and Implementation

注

Information in the following applications sections is not part of the TI component specification, and TI does not warrant its accuracy or completeness. TI's customers are responsible for determining suitability of components for their purposes. Customers should validate and test their design implementation to confirm system functionality.

9.1 Application Information

In this application, three channels of the CD74HCU04-Q1 are used to create an oscillator circuit as shown in [Figure 8](#). The additional three channels can be used for a second oscillator circuit, used individually for other applications, or the inputs can be grounded and the channels left unused.

The CD74HCU04-Q1 is used in place of an operational amplifier in an oscillator application. Similar to a conventional inverting amplifier design, this oscillator application depends on factors such as open-loop gain, power consumption, and duty-cycle variation with temperature. Unbuffered inverters have a single inverting stage with an AC signal gain in the range of 10 to 20 dB. Buffered inverters, by definition, have more than one stage of inversion and thus much higher gains, typically in the range of 60 to 70 dB. Due to the lower gain, unbuffered inverters help create a more stable oscillator which is less sensitive to parameter changes. The stability of this type of oscillator is sufficient for the majority of applications with frequencies in the range of 100 Hz to 100 kHz.

Frequency accuracy is affected by shifts in temperature, manufacturing process, supply voltage, and values of the external timing components. For applications that require an extremely accurate clock, it is recommended to use a crystal oscillator circuit or a dedicated oscillator IC instead.

9.2 Typical Application



图 8. Typical application schematic

9.2.1 Design Requirements

- This design utilizes a 5-V supply voltage, resulting in a 5-V output waveform.
- Low variance components should be used for the timing components (R_1 , R_2 , C_1 , C_2) as changes in these component values will cause changes in output frequency.
- For this application R_1 must have a much lower value than R_2 ($R_1 \ll R_2$).
- Short trace lengths will improve oscillator stability by reducing parasitics.

9.2.1.1 Power Considerations

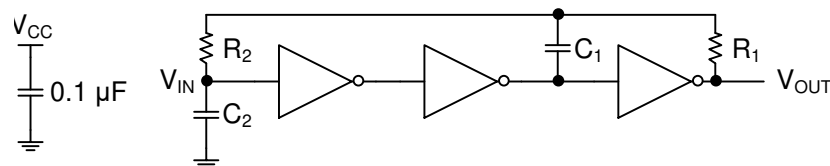
Ensure the desired supply voltage is within the range specified in the [Recommended Operating Conditions](#). The supply voltage sets the device's electrical characteristics as described in the [Electrical Characteristics](#). Changes to the supply will change the characteristics of the inverter, which will also change the oscillation frequency slightly.

Because the oscillator circuit biases two of the three stages of the device at approximately $V_{CC}/2$, both MOSFETs in the channels will be turned on and the supply current (I_{CC}) through the device will be much larger than that shown for operation as a CMOS logic device in the I_{CC} specification in the [Electrical Characteristics](#). This value will typically be between 10 and 30 mA per oscillator circuit.

The supply must be capable of sourcing current equal to the total current to be sourced by all outputs of the CD74HCU04-Q1 plus the maximum supply current, I_{CC} , listed in the [Electrical Characteristics](#). The logic device can only source or sink as much current as it is provided at the supply and ground pins, respectively. Be sure not to exceed the maximum total current through GND or V_{CC} listed in the [Absolute Maximum Ratings](#).

Typical Application (接下页)

Total power consumption can be calculated using the information provided in [CMOS Power Consumption and \$C_{pd}\$ Calculation](#).

Thermal increase can be calculated using the information provided in [Thermal Characteristics of Standard Linear and Logic \(SLL\) Packages and Devices](#).

CAUTION

The maximum junction temperature, $T_J(\text{max})$ listed in the [Absolute Maximum Ratings](#), is an *additional limitation* to prevent damage to the device. Do not violate any values listed in the [Absolute Maximum Ratings](#). These limits are provided to prevent damage to the device.

9.2.1.2 Input Considerations

Although the oscillator circuit described in [Application Information](#) does not exactly have an input, the CD74HCU04-Q1 device does have inputs. Be sure to connect all inputs either to a valid logic circuit or as part of the oscillator circuit provided. Attaching oscilloscope probes to nodes of an oscillator circuit can cause shifts in the operating frequency, especially if the timing capacitor values are very small (less than 100 pF).

Unused inputs must be terminated to either V_{CC} or ground. These inputs can be directly terminated if the input is completely unused, or they can be connected with a pull-up or pull-down resistor if the input is to be used sometimes, but not always. A pull-up resistor is used for a default state of HIGH, and a pull-down resistor is used for a default state of LOW. The resistor size is limited by drive current of the controller, leakage current into the CD74HCU04-Q1, as specified in the [Electrical Characteristics](#), and the desired input transition rate. A 10-k Ω resistor value is often used due to these factors.

Refer to the [Feature Description](#) for additional information regarding the inputs for this device.

9.2.1.3 Output Considerations

The output of the oscillator is a square wave at the supply voltage. This signal can be passed through an additional buffer or inverter stage to add additional drive strength without affecting the operation of the oscillator circuit.

The positive supply voltage is used to produce the output HIGH voltage. Drawing current from the output will decrease the output voltage as specified by the V_{OH} specification in the [Electrical Characteristics](#). Similarly, the ground voltage is used to produce the output LOW voltage. Sinking current into the output will increase the output voltage as specified by the V_{OL} specification in the [Electrical Characteristics](#). Unused outputs can be left floating.

Refer to [Feature Description](#) for additional information regarding the outputs for this device.

9.2.2 Detailed Design Procedure

1. Decide the frequency of operation required. Adjustments to the calculated values of the components may be required to get the desired frequency.
2. For the purpose of this design, we will not include C_2 and instead use the internal input capacitance of the buffer which is approximately 15 pF. C_2 should be added to the circuit to reduce overshoot and undershoot conditions on the inputs as shown in [Application Curves](#). Increasing the value of C_2 will slightly decrease the available output frequency.
3. To simplify the design, R_2 can be set to a large value. 100 k Ω is a good choice. Decreasing R_2 will slightly increase the available output frequency but will also increase the overshoot and undershoot on the input of the first buffer as shown in [Application Curves](#). The input signal should never exceed the absolute maximum ratings of the device.
4. Use the equation $f = 1/(2.2R_1C_1)$ to calculate the resistor and capacitor values for the desired frequency. Keep in mind the requirement that the value of $R_1 \ll R_2$ for the equation to remain valid.
5. Add a decoupling capacitor from V_{CC} to GND. The capacitor needs to be placed physically close to the device and electrically close to both the V_{CC} and GND pins. An example layout is shown in [Layout](#).

Typical Application (接下页)

6. Ensure the capacitive load at the output is ≤ 50 pF. This is not a hard limit, however it will ensure optimal performance. This can be accomplished by providing short, appropriately sized traces from the CD74HCU04-Q1 to the receiving device.
7. Testing this circuit in a simulation tool can be helpful for building confidence in the design, but it is necessary to build a prototype to guarantee proper operation as many factors can impact the stability of this oscillator.
8. Thermal issues are rarely a concern for logic gates, however the power consumption and thermal increase can be calculated using the steps provided in the application report, [CMOS Power Consumption and Cpd Calculation](#)

9.2.3 Application Curves



图 9. First stage input waveform with excessive overshoot and undershoot



图 10. First stage input waveform with marginal overshoot and undershoot

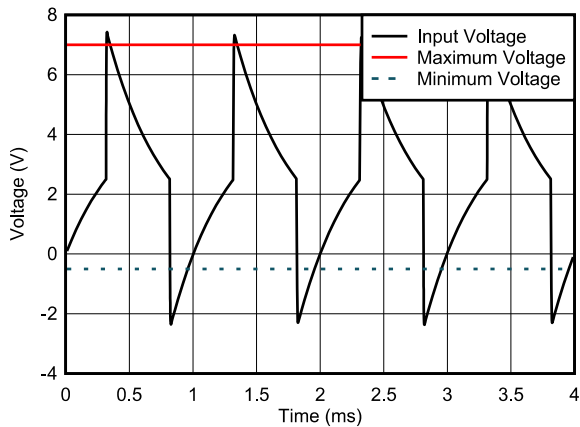

图 11. First stage input waveform for optimized circuit

10 Power Supply Recommendations

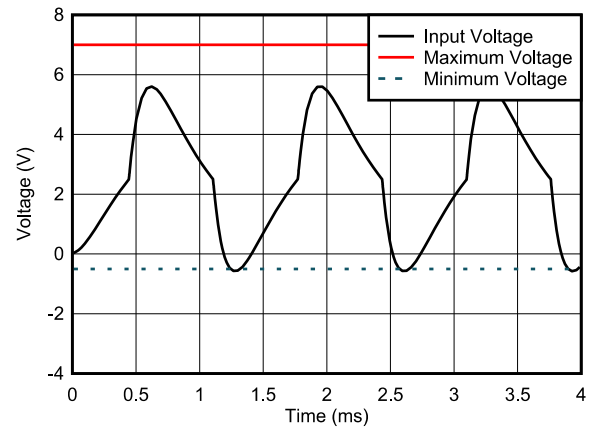
The power supply can be any voltage between the minimum and maximum supply voltage rating located in the [Recommended Operating Conditions](#). Each V_{CC} terminal should have a bypass capacitor to prevent power disturbance. A 0.1- μF capacitor is recommended for this device. It is acceptable to parallel multiple bypass caps to reject different frequencies of noise. The 0.1- μF and 1- μF capacitors are commonly used in parallel. The bypass capacitor should be installed as close to the power terminal as possible for best results, as shown in [Figure 12](#).

11 Layout

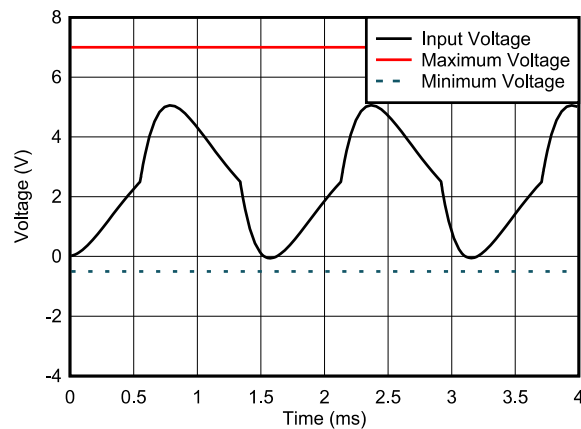
11.1 Layout Guidelines

When using multiple-input and multiple-channel logic devices inputs must not be left floating. In many cases, functions or parts of functions of digital logic devices are unused; for example, when only two inputs of a triple-input AND gate are used. Such unused input pins must not be left unconnected because the undefined voltages at the outside connections result in undefined operational states. All unused inputs of digital devices must be connected to a logic high or logic low voltage, as defined by the input voltage specifications, to prevent them from floating. The logic level that must be applied to any particular unused input depends on the function of the device. Generally, the inputs are tied to GND or V_{CC} , whichever makes more sense for the logic function or is more convenient.

11.2 Layout Example



图 12. Example layout for the CD74HCU04-Q1

12 器件和文档支持

12.1 文档支持

12.1.1 相关文档

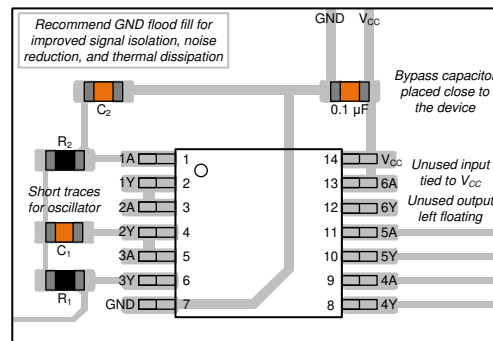
请参阅如下相关文档：

- 《在振荡器电路中使用 CMOS 非缓冲逆变器》
- 《HCMOS 设计注意事项》
- 《CMOS 功耗与 CPD 计算》
- 《使用逻辑器件进行设计》

12.2 相关链接

下表列出了快速访问链接。类别包括技术文档、支持与社区资源、工具和软件，以及申请样片或购买产品的快速链接。

12.3 社区资源

[TI E2E™ support forums](#) are an engineer's go-to source for fast, verified answers and design help — straight from the experts. Search existing answers or ask your own question to get the quick design help you need.

Linked content is provided "AS IS" by the respective contributors. They do not constitute TI specifications and do not necessarily reflect TI's views; see TI's [Terms of Use](#).

12.4 商标

E2E is a trademark of Texas Instruments.

All other trademarks are the property of their respective owners.

12.5 静电放电警告



这些装置包含有限的内置 ESD 保护。存储或装卸时，应将导线一起截短或将装置放置于导电泡棉中，以防止 MOS 门极遭受静电损伤。

12.6 Glossary

[SLYZ022](#) — *TI Glossary*.

This glossary lists and explains terms, acronyms, and definitions.

13 机械、封装和可订购信息

以下页面包含机械、封装和可订购信息。这些信息是指定器件的最新可用数据。数据如有变更，恕不另行通知，且不会对此文档进行修订。如需获取此数据表的浏览器版本，请查阅左侧的导航栏。

PACKAGING INFORMATION

Orderable Device	Status (1)	Package Type	Package Drawing	Pins	Package Qty	Eco Plan (2)	Lead finish/ Ball material (6)	MSL Peak Temp (3)	Op Temp (°C)	Device Marking (4/5)	Samples
CD74HCU04QPWRQ1	ACTIVE	TSSOP	PW	14	2000	RoHS & Green	NIPDAU	Level-1-260C-UNLIM	-40 to 125	HJU04Q	Samples

(1) The marketing status values are defined as follows:

ACTIVE: Product device recommended for new designs.

LIFEBUY: TI has announced that the device will be discontinued, and a lifetime-buy period is in effect.

NRND: Not recommended for new designs. Device is in production to support existing customers, but TI does not recommend using this part in a new design.

PREVIEW: Device has been announced but is not in production. Samples may or may not be available.

OBSELETE: TI has discontinued the production of the device.

(2) **RoHS:** TI defines "RoHS" to mean semiconductor products that are compliant with the current EU RoHS requirements for all 10 RoHS substances, including the requirement that RoHS substance do not exceed 0.1% by weight in homogeneous materials. Where designed to be soldered at high temperatures, "RoHS" products are suitable for use in specified lead-free processes. TI may reference these types of products as "Pb-Free".

RoHS Exempt: TI defines "RoHS Exempt" to mean products that contain lead but are compliant with EU RoHS pursuant to a specific EU RoHS exemption.

Green: TI defines "Green" to mean the content of Chlorine (Cl) and Bromine (Br) based flame retardants meet JS709B low halogen requirements of <=1000ppm threshold. Antimony trioxide based flame retardants must also meet the <=1000ppm threshold requirement.

(3) MSL, Peak Temp. - The Moisture Sensitivity Level rating according to the JEDEC industry standard classifications, and peak solder temperature.

(4) There may be additional marking, which relates to the logo, the lot trace code information, or the environmental category on the device.

(5) Multiple Device Markings will be inside parentheses. Only one Device Marking contained in parentheses and separated by a "-" will appear on a device. If a line is indented then it is a continuation of the previous line and the two combined represent the entire Device Marking for that device.

(6) Lead finish/Ball material - Orderable Devices may have multiple material finish options. Finish options are separated by a vertical ruled line. Lead finish/Ball material values may wrap to two lines if the finish value exceeds the maximum column width.

Important Information and Disclaimer:The information provided on this page represents TI's knowledge and belief as of the date that it is provided. TI bases its knowledge and belief on information provided by third parties, and makes no representation or warranty as to the accuracy of such information. Efforts are underway to better integrate information from third parties. TI has taken and continues to take reasonable steps to provide representative and accurate information but may not have conducted destructive testing or chemical analysis on incoming materials and chemicals. TI and TI suppliers consider certain information to be proprietary, and thus CAS numbers and other limited information may not be available for release.

In no event shall TI's liability arising out of such information exceed the total purchase price of the TI part(s) at issue in this document sold by TI to Customer on an annual basis.

TAPE AND REEL INFORMATION

QUADRANT ASSIGNMENTS FOR PIN 1 ORIENTATION IN TAPE

*All dimensions are nominal

Device	Package Type	Package Drawing	Pins	SPQ	Reel Diameter (mm)	Reel Width W1 (mm)	A0 (mm)	B0 (mm)	K0 (mm)	P1 (mm)	W (mm)	Pin1 Quadrant
CD74HCU04QPWRQ1	TSSOP	PW	14	2000	330.0	12.4	6.9	5.6	1.6	8.0	12.0	Q1

TAPE AND REEL BOX DIMENSIONS

*All dimensions are nominal

Device	Package Type	Package Drawing	Pins	SPQ	Length (mm)	Width (mm)	Height (mm)
CD74HCU04QPWRQ1	TSSOP	PW	14	2000	853.0	449.0	35.0

PW (R-PDSO-G14)

PLASTIC SMALL OUTLINE



- NOTES:
- All linear dimensions are in millimeters.
 - This drawing is subject to change without notice.
 - Publication IPC-7351 is recommended for alternate designs.
 - Laser cutting apertures with trapezoidal walls and also rounding corners will offer better paste release. Customers should contact their board assembly site for stencil design recommendations. Refer to IPC-7525 for other stencil recommendations.
 - Customers should contact their board fabrication site for solder mask tolerances between and around signal pads.

重要声明和免责声明

TI“按原样”提供技术和可靠性数据（包括数据表）、设计资源（包括参考设计）、应用或其他设计建议、网络工具、安全信息和其他资源，不保证没有瑕疵且不做任何明示或暗示的担保，包括但不限于对适销性、某特定用途方面的适用性或不侵犯任何第三方知识产权的暗示担保。

这些资源可供使用 TI 产品进行设计的熟练开发人员使用。您将自行承担以下全部责任：(1) 针对您的应用选择合适的 TI 产品，(2) 设计、验证并测试您的应用，(3) 确保您的应用满足相应标准以及任何其他功能安全、信息安全、监管或其他要求。

这些资源如有变更，恕不另行通知。TI 授权您仅可将这些资源用于研发本资源所述的 TI 产品的应用。严禁对这些资源进行其他复制或展示。您无权使用任何其他 TI 知识产权或任何第三方知识产权。您应全额赔偿因在这些资源的使用中对 TI 及其代表造成的任何索赔、损害、成本、损失和债务，TI 对此概不负责。

TI 提供的产品受 [TI 的销售条款](#) 或 [ti.com](#) 上其他适用条款/TI 产品随附的其他适用条款的约束。TI 提供这些资源并不会扩展或以其他方式更改 TI 针对 TI 产品发布的适用的担保或担保免责声明。

TI 反对并拒绝您可能提出的任何其他或不同的条款。

邮寄地址：Texas Instruments, Post Office Box 655303, Dallas, Texas 75265
Copyright © 2021，德州仪器 (TI) 公司