

TS3A24157 0.65-Ω 2-Channel SPDT Analog Switch 2-Channel 2:1 Multiplexer and Demultiplexer

1 Features

- Specified Break-Before-Make Switching
- Low ON-State Resistance (0.65-Ω Maximum)
- Low Charge Injection
- Excellent ON-State Resistance Matching
- Low Total Harmonic Distortion
- 1.65-V to 3.6-V Single-Supply Operation
- Bidirectional Signal Paths
- Latch-Up Performance Exceeds 100 mA Per JESD 78, Class II
- ESD Performance Tested Per JESD 22
 - 2000-V Human-Body Model (A114-B, Class II)
 - 1000-V Charged-Device Model (C101)

2 Applications

- Cell Phones
- PDAs
- Portable Instrumentation
- Audio and Video Signal Routing
- Low-Voltage Data Acquisition Systems
- Communication Circuits
- Modems
- Hard Drives
- Computer Peripherals
- Wireless Terminals and Peripherals

3 Description

The TS3A24157 is a bidirectional, 2-channel, single-pole double-throw (SPDT) analog switch that is designed to operate from 1.65 V to 3.6 V. The device offers low ON-state resistance and excellent ON-state resistance matching with the break-before-make feature, to prevent signal distortion during the transfer of a signal from one channel to another. The device has excellent total harmonic distortion (THD) performance and consumes very-low power. These features make this device suitable for portable audio applications.

Device Information⁽¹⁾

PART NUMBER	PACKAGE	BODY SIZE (NOM)
TS3A24157	UQFN (10)	1.50 mm × 2.00 mm
	VSSOP (10)	3.00 mm × 3.00 mm

(1) For all available packages, see the orderable addendum at the end of the data sheet.

Functional Block Diagram

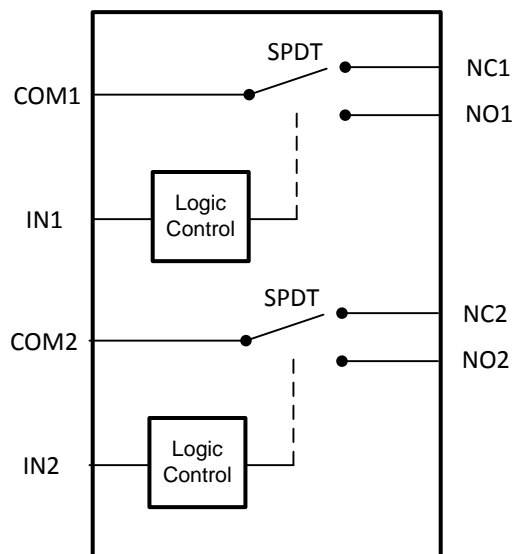

Copyright © 2016, Texas Instruments Incorporated



5 Pin Configuration and Functions

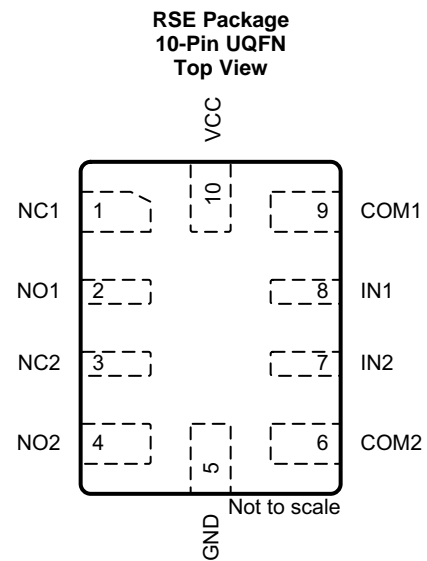
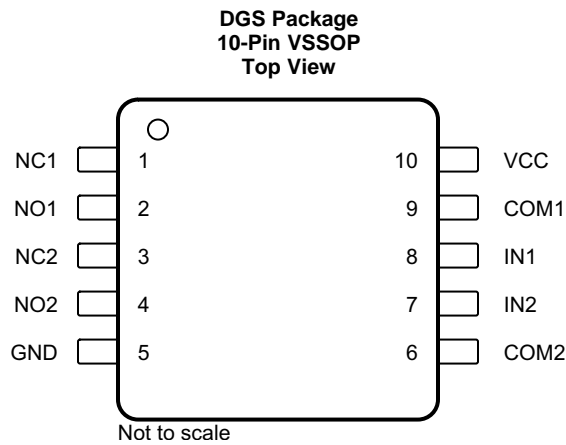

Pin Functions

PIN		I/O	DESCRIPTION
NO.	NAME		
1	NC1	I/O	Normally closed signal path
2	NO1	I/O	Normally open signal path
3	NC2	I/O	Normally closed signal path
4	NO2	I/O	Normally open signal path
5	GND	—	Ground
6	COM2	I/O	Common signal path
7	IN2	I	Digital control to connect COM2 to NO2 or NC2
8	IN1	I	Digital control to connect COM1 to NO1 or NC1
9	COM1	I/O	Common signal path
10	VCC	—	Power supply

6 Specifications

6.1 Absolute Maximum Ratings

 over operating free-air temperature range (unless otherwise noted)⁽¹⁾⁽²⁾⁽³⁾

		MIN	MAX	UNIT
Supply voltage		-0.5	3.6	V
Analog signal voltage ⁽⁴⁾		-0.5	$V_{CC} + 0.5$	V
Digital input voltage		-0.5	3.6	V
Analog port diode current	$V_{NC}, V_{NO}, V_{COM} < 0$	-50	50	mA
ON-state switch current	$V_{NC}, V_{NO}, V_{COM} = 0$ to V_{CC}	-300	300	mA
ON-state peak switch current ⁽⁵⁾	$V_{NC}, V_{NO}, V_{COM} = 0$ to V_{CC}	-500	500	mA
Digital input clamp current	$V_{IN} < 0$	-50		mA
Continuous current through VCC			100	mA
Continuous current through GND		-100		mA
Storage temperature, T_{stg}		-65	150	°C

- (1) Stresses beyond those listed under *Absolute Maximum Ratings* may cause permanent damage to the device. These are stress ratings only, which do not imply functional operation of the device at these or any other conditions beyond those indicated under *Recommended Operating Conditions*. Exposure to absolute-maximum-rated conditions for extended periods may affect device reliability.
- (2) All voltages are with respect to ground, unless otherwise specified.
- (3) The algebraic convention, whereby the most negative value is a minimum and the most positive value is a maximum.
- (4) This value is limited to 5.5 V (maximum).
- (5) Pulse at 1-ms duration < 10% duty cycle.

6.2 ESD Ratings

		VALUE	UNIT
$V_{(ESD)}$ Electrostatic discharge	Human-body model (HBM), per ANSI/ESDA/JEDEC JS-001 ⁽¹⁾	±2000	V
	Charged-device model (CDM), per JEDEC specification JESD22-C101 ⁽²⁾	±1000	

- (1) JEDEC document JEP155 states that 500-V HBM allows safe manufacturing with a standard ESD control process.
- (2) JEDEC document JEP157 states that 250-V CDM allows safe manufacturing with a standard ESD control process.

6.3 Recommended Operating Conditions

over operating free-air temperature range (unless otherwise noted)

		MIN	MAX	UNIT
V_{CC}	Supply voltage	1.65	3.6	V
V_{NC}	Analog signal voltage	0	V_{CC}	V
V_{NO}		0	V_{CC}	
V_{COM}		0	V_{CC}	
V_{IN}	Digital input voltage	0	V_{CC}	V

6.4 Thermal Information

THERMAL METRIC ⁽¹⁾		TS3A24157		UNIT
		DGS (VSSOP)	RSE (UQFN)	
		10 PINS	10 PINS	
$R_{\theta JA}$	Junction-to-ambient thermal resistance	188.5	160.3	°C/W
$R_{\theta JC(top)}$	Junction-to-case (top) thermal resistance	76.5	77.8	°C/W
$R_{\theta JB}$	Junction-to-board thermal resistance	108.2	82.2	°C/W
ψ_{JT}	Junction-to-top characterization parameter	15.3	4.3	°C/W
ψ_{JB}	Junction-to-board characterization parameter	106.8	82.2	°C/W

- (1) For more information about traditional and new thermal metrics, see the *Semiconductor and IC Package Thermal Metrics* application report.

6.5 Electrical Characteristics: 3-V Supply

 $V_{CC} = 3\text{ V}$, $T_A = 25^\circ\text{C}$ (unless otherwise noted)

PARAMETER		TEST CONDITIONS		MIN	TYP	MAX	UNIT
ANALOG SWITCH							
r_{PEAK}	Peak ON resistance	$0 \leq (V_{NC} \text{ or } V_{NO}) \leq V_{CC}$; $V_{CC} = 2.7\text{ V}$, $I_{COM} = -100\text{ mA}$, Switch ON, See Figure 10	$T_A = 25^\circ\text{C}$ $-40^\circ\text{C} \leq T_A \leq 85^\circ\text{C}$		0.5	0.65	Ω
r_{ON}	ON-state resistance	$V_{NC} \text{ or } V_{NO} = 2\text{ V}$, $V_{CC} = 2.7\text{ V}$, $I_{COM} = -100\text{ mA}$, Switch ON, See Figure 10	$T_A = 25^\circ\text{C}$ $-40^\circ\text{C} \leq T_A \leq 85^\circ\text{C}$		0.45	0.6	Ω
Δr_{ON}	ON-state resistance match between channels	$V_{NC} \text{ or } V_{NO} = 2\text{ V or } 0.8\text{ V}$, $V_{CC} = 2.7\text{ V}$, $I_{COM} = -100\text{ mA}$, Switch ON, See Figure 10	$T_A = 25^\circ\text{C}$ $-40^\circ\text{C} \leq T_A \leq 85^\circ\text{C}$		0.05	0.07	Ω
$r_{ON(FLAT)}$	ON-state resistance flatness	$V_{CC} = 2.7\text{ V}$, $I_{COM} = -100\text{ mA}$, Switch ON, See Figure 10	$0 \leq (V_{NC} \text{ or } V_{NO}) \leq V_{CC}$ $V_{NC} \text{ or } V_{NO} = 2\text{ V or } 0.8\text{ V}$ $T_A = 25^\circ\text{C}$ $-40^\circ\text{C} \leq T_A \leq 85^\circ\text{C}$		0.025	0.01	Ω
$I_{NC(OFF)}$, $I_{NO(OFF)}$	NC and NO OFF leakage current	$V_{NC} \text{ or } V_{NO} = 1\text{ V}$ and $V_{COM} = 3\text{ V}$, or $V_{NC} \text{ or } V_{NO} = 3\text{ V}$ and $V_{COM} = 1\text{ V}$; $V_{CC} = 3.6\text{ V}$, Switch OFF, See Figure 11	$T_A = 25^\circ\text{C}$ $-40^\circ\text{C} \leq T_A \leq 85^\circ\text{C}$	-50		50	nA
$I_{NC(ON)}$, $I_{NO(ON)}$	NC and NO ON leakage current	$V_{NC} \text{ or } V_{NO} = 1\text{ V or } 3\text{ V}$, $V_{COM} = \text{Open}$, $V_{CC} = 3.6\text{ V}$, Switch ON, See Figure 12	$T_A = 25^\circ\text{C}$ $-40^\circ\text{C} \leq T_A \leq 85^\circ\text{C}$	-50		50	nA
$I_{COM(ON)}$	COM ON leakage current	$V_{NC} \text{ or } V_{NO} = \text{Open}$, $V_{COM} = 1\text{ V or } 3\text{ V}$, $V_{CC} = 3.6\text{ V}$, Switch ON, See Figure 12	$T_A = 25^\circ\text{C}$ $-40^\circ\text{C} \leq T_A \leq 85^\circ\text{C}$	-50		50	nA
DIGITAL CONTROL INPUTS (IN1, IN2)⁽¹⁾							
V_{IH}	Input logic high	$2.7\text{ V} \leq V_{CC} \leq 3.6\text{ V}$, $-40^\circ\text{C} \leq T_A \leq 85^\circ\text{C}$		1.4			V
V_{IL}	Input logic low	$2.7\text{ V} \leq V_{CC} \leq 3.6\text{ V}$, $-40^\circ\text{C} \leq T_A \leq 85^\circ\text{C}$				0.5	V
I_{IH} , I_{IL}	Input leakage current	$V_{IN} = 3.6\text{ V or GND}$, $V_{CC} = 3.6\text{ V}$	$T_A = 25^\circ\text{C}$ $-40^\circ\text{C} \leq T_A \leq 85^\circ\text{C}$	-50	5	50	nA
DYNAMIC							
t_{ON}	Turnon time	$V_{COM} = V_{CC}$, $R_L = 50\ \Omega$, $C_L = 35\text{ pF}$, See Figure 14	$V_{CC} = 3\text{ V}$, $T_A = 25^\circ\text{C}$ $2.7\text{ V} \leq V_{CC} \leq 3.6\text{ V}$, $-40^\circ\text{C} \leq T_A \leq 85^\circ\text{C}$		20	35	ns
t_{OFF}	Turnoff time	$V_{COM} = V_{CC}$, $R_L = 50\ \Omega$, $C_L = 35\text{ pF}$, See Figure 14	$V_{CC} = 3\text{ V}$, $T_A = 25^\circ\text{C}$ $2.7\text{ V} \leq V_{CC} \leq 3.6\text{ V}$, $-40^\circ\text{C} \leq T_A \leq 85^\circ\text{C}$		12	25	ns
t_{BBM}	Break-before-make time	$V_{NC} = V_{NO} = V_{CC}$, $R_L = 50\ \Omega$, $C_L = 35\text{ pF}$, See Figure 15	$V_{CC} = 3\text{ V}$, $T_A = 25^\circ\text{C}$ $2.7\text{ V} \leq V_{CC} \leq 3.6\text{ V}$, $-40^\circ\text{C} \leq T_A \leq 85^\circ\text{C}$	1	10	25	ns
Q_C	Charge injection	$V_{GEN} = 0$, $R_{GEN} = 0$, $C_L = 1\text{ nF}$, See Figure 19			8.75		pC
$C_{NC(OFF)}$, $C_{NO(OFF)}$	NC and NO OFF capacitance	$(V_{NC} \text{ or } V_{NO}) = V_{CC} \text{ or GND}$, Switch OFF, See Figure 13			50		pF
$C_{NC(ON)}$, $C_{NO(ON)}$	NC and NO ON capacitance	$(V_{NC} \text{ or } V_{NO}) = V_{CC} \text{ or GND}$, Switch ON, See Figure 13			140		pF
$C_{COM(ON)}$	COM ON capacitance	$V_{COM} = V_{CC} \text{ or GND}$, Switch ON, See Figure 13			140		pF
C_I	Digital input capacitance	$V_{IN} = V_{CC} \text{ or GND}$, See Figure 13			2		pF
BW	Bandwidth	$R_L = 50\ \Omega$, Switch ON, See Figure 16			50		MHz
O_{ISO}	OFF isolation	$R_L = 50\ \Omega$, $f = 1\text{ MHz}$, See Figure 17			-72		dB
X_{TALK}	Crosstalk	$R_L = 50\ \Omega$, $f = 1\text{ MHz}$, See Figure 18			-72		dB
THD	Total harmonic distortion	$R_L = 600\ \Omega$, $C_L = 50\text{ pF}$, $f = 20\text{ Hz to } 20\text{ kHz}$, See Figure 20			0.005%		
SUPPLY							
I_{CC}	Positive supply current	$V_{IN} = V_{CC} \text{ or GND}$, $V_{CC} = 3.6\text{ V}$	$T_A = 25^\circ\text{C}$ $-40^\circ\text{C} \leq T_A \leq 85^\circ\text{C}$		15	200	nA
						1200	

(1) All unused digital inputs of the device must be held at V_{CC} or GND to ensure proper device operation. See [Implications of Slow or Floating CMOS Inputs](#).

6.6 Electrical Characteristics: 2.5-V Supply

 $V_{CC} = 2.5\text{ V}$, $T_A = 25^\circ\text{C}$ (unless otherwise noted)

PARAMETER		TEST CONDITIONS	MIN	TYP	MAX	UNIT
ANALOG SWITCH						
r_{PEAK}	Peak ON resistance	$0 \leq (V_{NO} \text{ or } V_{NC}) \leq V_{CC}$; $V_{CC} = 2.3\text{ V}$, $I_{COM} = -8\text{ mA}$, Switch ON, See Figure 10	$T_A = 25^\circ\text{C}$ $-40^\circ\text{C} \leq T_A \leq 85^\circ\text{C}$	0.55	0.75	Ω
r_{ON}	ON-state resistance	$V_{NO} \text{ or } V_{NC} = 1.8\text{ V}$, $V_{CC} = 2.3\text{ V}$, $I_{COM} = -8\text{ mA}$, Switch ON, See Figure 10	$T_A = 25^\circ\text{C}$ $-40^\circ\text{C} \leq T_A \leq 85^\circ\text{C}$	0.56	0.75	Ω
Δr_{ON}	ON-state resistance match between channels	$V_{NO} \text{ or } V_{NC} = 1.8\text{ V or } 0.8\text{ V}$, $V_{CC} = 2.3\text{ V}$, $I_{COM} = -8\text{ mA}$, Switch ON, See Figure 10	$T_A = 25^\circ\text{C}$ $-40^\circ\text{C} \leq T_A \leq 85^\circ\text{C}$	0.1	0.15	Ω
$r_{ON(FLAT)}$	ON-state resistance flatness	$V_{CC} = 2.3\text{ V}$, $I_{COM} = -8\text{ mA}$, Switch ON, See Figure 10	$0 \leq (V_{NO} \text{ or } V_{NC}) \leq V_{CC}$ $V_{NO} \text{ or } V_{NC} = 0.8\text{ V or } 1.8\text{ V}$ $T_A = 25^\circ\text{C}$ $-40^\circ\text{C} \leq T_A \leq 85^\circ\text{C}$	0.1	0.15	Ω
$I_{NC(OFF)}$, $I_{NO(OFF)}$	NC and NO OFF leakage current	$V_{NC} \text{ or } V_{NO} = 0.5\text{ V}$ and $V_{COM} = 2.2\text{ V}$, or $V_{NC} \text{ or } V_{NO} = 2.2\text{ V}$ and $V_{COM} = 0.5\text{ V}$; $V_{CC} = 2.7\text{ V}$, Switch OFF, See Figure 11	$T_A = 25^\circ\text{C}$ $-40^\circ\text{C} \leq T_A \leq 85^\circ\text{C}$	-50	50	nA
$I_{NC(ON)}$, $I_{NO(ON)}$	NC and NO ON leakage current	$V_{NC} \text{ or } V_{NO} = 0.5\text{ V or } 2.2\text{ V}$, $V_{COM} = \text{Open}$, $V_{CC} = 2.7\text{ V}$, Switch ON, See Figure 12	$T_A = 25^\circ\text{C}$ $-40^\circ\text{C} \leq T_A \leq 85^\circ\text{C}$	-50	50	nA
$I_{COM(ON)}$	COM ON leakage current	$V_{NC} \text{ or } V_{NO} = \text{Open}$, $V_{COM} = 0.5\text{ V or } 2.2\text{ V}$, $V_{CC} = 2.7\text{ V}$, Switch ON, See Figure 12	$T_A = 25^\circ\text{C}$ $-40^\circ\text{C} \leq T_A \leq 85^\circ\text{C}$	-50	50	nA
DIGITAL CONTROL INPUTS (IN1, IN2)⁽¹⁾						
V_{IH}	Input logic high	$2.3\text{ V} \leq V_{CC} \leq 2.7\text{ V}$, $-40^\circ\text{C} \leq T_A \leq 85^\circ\text{C}$		1.25		V
V_{IL}	Input logic low	$2.3\text{ V} \leq V_{CC} \leq 2.7\text{ V}$, $-40^\circ\text{C} \leq T_A \leq 85^\circ\text{C}$			0.5	V
I_{IH} , I_{IL}	Input leakage current	$V_{IN} = 2.7\text{ V or GND}$, $V_{CC} = 2.7\text{ V}$	$T_A = 25^\circ\text{C}$ $-40^\circ\text{C} \leq T_A \leq 85^\circ\text{C}$	-50	50	nA
DYNAMIC						
t_{ON}	Turnon time	$V_{COM} = V_{CC}$, $R_L = 50\ \Omega$, $C_L = 35\text{ pF}$, See Figure 14	$V_{CC} = 2.5\text{ V}$, $T_A = 25^\circ\text{C}$ $2.3\text{ V} \leq V_{CC} \leq 2.7\text{ V}$, $-40^\circ\text{C} \leq T_A \leq 85^\circ\text{C}$	23	45	ns
t_{OFF}	Turnoff time	$V_{COM} = V_{CC}$, $R_L = 50\ \Omega$, $C_L = 35\text{ pF}$, See Figure 14	$V_{CC} = 2.5\text{ V}$, $T_A = 25^\circ\text{C}$ $2.3\text{ V} \leq V_{CC} \leq 2.7\text{ V}$, $-40^\circ\text{C} \leq T_A \leq 85^\circ\text{C}$	17	27	ns
t_{BBM}	Break-before- make time	$V_{NC} = V_{NO} = V_{CC}$, $R_L = 50\ \Omega$, $C_L = 35\text{ pF}$, See Figure 15	$V_{CC} = 2.5\text{ V}$, $T_A = 25^\circ\text{C}$ $2.3\text{ V} \leq V_{CC} \leq 2.7\text{ V}$, $-40^\circ\text{C} \leq T_A \leq 85^\circ\text{C}$	2	14	ns
Q_C	Charge injection	$V_{GEN} = 0$, $R_{GEN} = 0$, $C_L = 1\text{ nF}$, See Figure 19		8		pC
$C_{NC(OFF)}$, $C_{NO(OFF)}$	NC and NO OFF capacitance	$V_{NC} \text{ or } V_{NO} = V_{CC} \text{ or GND}$, Switch OFF, See Figure 13		50		pF
$C_{NC(ON)}$, $C_{NO(ON)}$	NC and NO ON capacitance	$V_{NC} \text{ or } V_{NO} = V_{CC} \text{ or GND}$, Switch ON, See Figure 13		140		pF
$C_{COM(ON)}$	COM ON capacitance	$V_{COM} = V_{CC} \text{ or GND}$, Switch ON, See Figure 13		140		pF
C_I	Digital input capacitance	$V_{IN} = V_{CC} \text{ or GND}$, See Figure 13		2		pF
BW	Bandwidth	$R_L = 50\ \Omega$, Switch ON, See Figure 16		50		MHz
O_{ISO}	OFF isolation	$R_L = 50\ \Omega$, $f = 1\text{ MHz}$, See Figure 17		-72		dB
X_{TALK}	Crosstalk	$R_L = 50\ \Omega$, $f = 1\text{ MHz}$, See Figure 18		-72		dB
THD	Total harmonic distortion	$R_L = 600\ \Omega$, $C_L = 50\text{ pF}$, $f = 20\text{ Hz to } 20\text{ kHz}$, See Figure 20		0.006%		
SUPPLY						
I_{CC}	Positive supply current	$V_{IN} = V_{CC} \text{ or GND}$, $V_{CC} = 2.7\text{ V}$	$T_A = 25^\circ\text{C}$ $-40^\circ\text{C} \leq T_A \leq 85^\circ\text{C}$	10	150	nA

(1) All unused digital inputs of the device must be held at V_{CC} or GND to ensure proper device operation. See [Implications of Slow or Floating CMOS Inputs](#).

6.7 Electrical Characteristics: 1.8-V Supply

 $V_{CC} = 1.8\text{ V}$, $T_A = 25^\circ\text{C}$ (unless otherwise noted)

PARAMETER		TEST CONDITIONS		MIN	TYP	MAX	UNIT
ANALOG SWITCH							
r_{PEAK}	Peak ON resistance	$0 \leq (V_{NO} \text{ or } V_{NC}) \leq V_{CC}$, $V_{CC} = 1.65\text{ V}$, $I_{COM} = -2\text{ mA}$, Switch ON, See Figure 10	$T_A = 25^\circ\text{C}$ $-40^\circ\text{C} \leq T_A \leq 85^\circ\text{C}$	0.8		1.25 1.4	Ω
r_{ON}	ON-state resistance	$V_{NO} \text{ or } V_{NC} = 1.5\text{ V}$, $V_{CC} = 1.65\text{ V}$, $I_{COM} = -2\text{ mA}$, Switch ON, See Figure 10	$T_A = 25^\circ\text{C}$ $-40^\circ\text{C} \leq T_A \leq 85^\circ\text{C}$	0.6		0.95 1	Ω
Δr_{ON}	ON-state resistance match between channels	$V_{NO} \text{ or } V_{NC} = 0.6\text{ V}$ or 1.5 V , $V_{CC} = 1.65\text{ V}$, $I_{COM} = -2\text{ mA}$, Switch ON, See Figure 10	$T_A = 25^\circ\text{C}$ $-40^\circ\text{C} \leq T_A \leq 85^\circ\text{C}$	0.1		0.15 0.15	Ω
$r_{ON(FLAT)}$	ON-state resistance flatness	$V_{CC} = 1.65\text{ V}$, $I_{COM} = -2\text{ mA}$, Switch ON, See Figure 10	$0 \leq (V_{NO} \text{ or } V_{NC}) \leq V_{CC}$ $V_{NO} \text{ or } V_{NC} = 0.6\text{ V}$ or 1.5 V			0.35 0.13 0.05 0.2	Ω
$I_{NC(OFF)}$, $I_{NO(OFF)}$	NC and NO OFF leakage current	$V_{NC} \text{ or } V_{NO} = 0.3\text{ V}$ and $V_{COM} = 1.65\text{ V}$, or $V_{NC} \text{ or } V_{NO} = 1.65\text{ V}$ and $V_{COM} = 0.3\text{ V}$; $V_{CC} = 1.65$, Switch OFF, See Figure 11	$T_A = 25^\circ\text{C}$ $-40^\circ\text{C} \leq T_A \leq 85^\circ\text{C}$	-50		50 250	nA
$I_{NC(ON)}$, $I_{NO(ON)}$	NC and NO ON leakage current	$V_{NC} \text{ or } V_{NO} = 0.3\text{ V}$ or 1.65 V , $V_{COM} = \text{Open}$, $V_{CC} = 1.95\text{ V}$, Switch ON, See Figure 12	$T_A = 25^\circ\text{C}$ $-40^\circ\text{C} \leq T_A \leq 85^\circ\text{C}$	-50		50 400	nA
$I_{COM(ON)}$	COM ON leakage current	$V_{NC} \text{ or } V_{NO} = \text{Open}$, $V_{COM} = 0.3\text{ V}$ or 1.65 V , $V_{CC} = 1.95\text{ V}$, Switch ON, See Figure 12	$T_A = 25^\circ\text{C}$ $-40^\circ\text{C} \leq T_A \leq 85^\circ\text{C}$	-50		50 400	nA
DIGITAL CONTROL INPUTS (IN1, IN2)⁽¹⁾							
V_{IH}	Input logic high	$1.65\text{ V} \leq V_{CC} \leq 1.95\text{ V}$, $-40^\circ\text{C} \leq T_A \leq 85^\circ\text{C}$		1			V
V_{IL}	Input logic low	$1.65\text{ V} \leq V_{CC} \leq 1.95\text{ V}$, $-40^\circ\text{C} \leq T_A \leq 85^\circ\text{C}$				0.4	V
I_{IH} , I_{IL}	Input leakage current	$V_{IN} = 1.95\text{ V}$ or GND, $V_{CC} = 1.95\text{ V}$	25°C $-40^\circ\text{C} \leq T_A \leq 85^\circ\text{C}$		0	50 150	nA
DYNAMIC							
t_{ON}	Turnon time	$V_{COM} = V_{CC}$, $R_L = 50\ \Omega$, $C_L = 35\text{ pF}$, See Figure 14	$V_{CC} = 1.8\text{ V}$, $T_A = 25^\circ\text{C}$ $1.65\text{ V} \leq V_{CC} \leq 1.95\text{ V}$, $-40^\circ\text{C} \leq T_A \leq 85^\circ\text{C}$		33	75 80	ns
t_{OFF}	Turnoff time	$V_{COM} = V_{CC}$, $R_L = 50\ \Omega$, $C_L = 35\text{ pF}$, See Figure 14	$V_{CC} = 1.8\text{ V}$, $T_A = 25^\circ\text{C}$ $1.65\text{ V} \leq V_{CC} \leq 1.95\text{ V}$, $-40^\circ\text{C} \leq T_A \leq 85^\circ\text{C}$		24	35 40	ns
t_{BBM}	Break-before- make time	$V_{NC} = V_{NO} = V_{CC}$, $R_L = 50\ \Omega$, $C_L = 35\text{ pF}$, See Figure 15	$V_{CC} = 1.8\text{ V}$, $T_A = 25^\circ\text{C}$ $1.65\text{ V} \leq V_{CC} \leq 1.95\text{ V}$, $-40^\circ\text{C} \leq T_A \leq 85^\circ\text{C}$		2	20 40 50	ns
Q_C	Charge injection	$V_{GEN} = 0$, $R_{GEN} = 0$, $C_L = 1\text{ nF}$, See Figure 19			4		pC
$C_{NC(OFF)}$, $C_{NO(OFF)}$	NC and NO OFF capacitance	$V_{NC} \text{ or } V_{NO} = V_{CC}$ or GND, Switch OFF, See Figure 13			50		pF
$C_{NC(ON)}$, $C_{NO(ON)}$	NC and NO ON capacitance	$V_{NC} \text{ or } V_{NO} = V_{CC}$ or GND, Switch ON, See Figure 13			140		pF
$C_{COM(ON)}$	COM ON capacitance	$V_{COM} = V_{CC}$ or GND, Switch ON, See Figure 13			140		pF
C_I	Digital input capacitance	$V_{IN} = V_{CC}$ or GND, See Figure 13			2		pF
BW	Bandwidth	$R_L = 50\ \Omega$, Switch ON, See Figure 16			48		MHz
O_{ISO}	OFF isolation	$R_L = 50\ \Omega$, $f = 1\text{ MHz}$, See Figure 17			-73		dB
X_{TALK}	Crosstalk	$R_L = 50\ \Omega$, $f = 1\text{ MHz}$, See Figure 18			-72		dB
THD	Total harmonic distortion	$R_L = 600\ \Omega$, $C_L = 50\text{ pF}$, $f = 20\text{ Hz}$ to 20 kHz , See Figure 20			0.005%		
Supply							
I_{CC}	Positive supply current	$V_{IN} = V_{CC}$ or GND, $V_{CC} = 1.95\text{ V}$	$T_A = 25^\circ\text{C}$ $-40^\circ\text{C} \leq T_A \leq 85^\circ\text{C}$		10	100 600	nA

(1) All unused digital inputs of the device must be held at V_{CC} or GND to ensure proper device operation. See [Implications of Slow or Floating CMOS Inputs](#).

6.8 Typical Characteristics

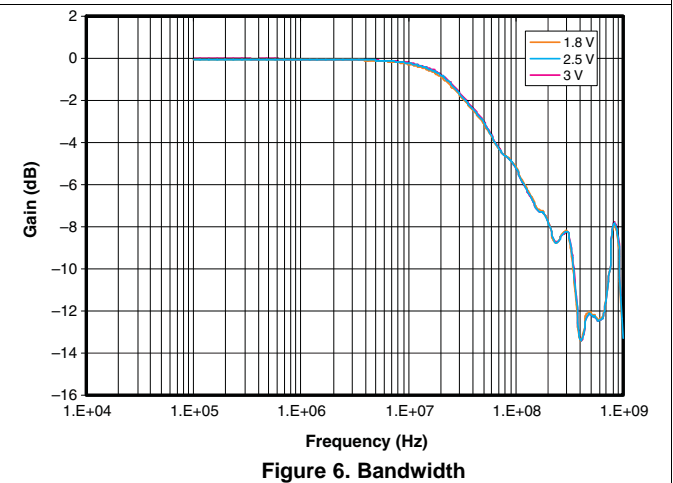
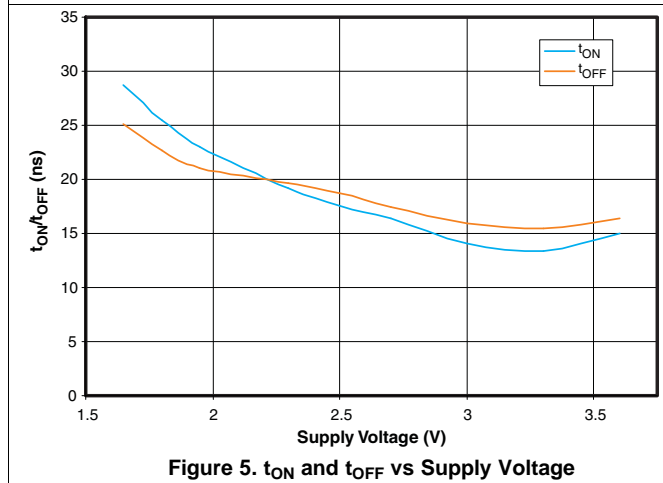
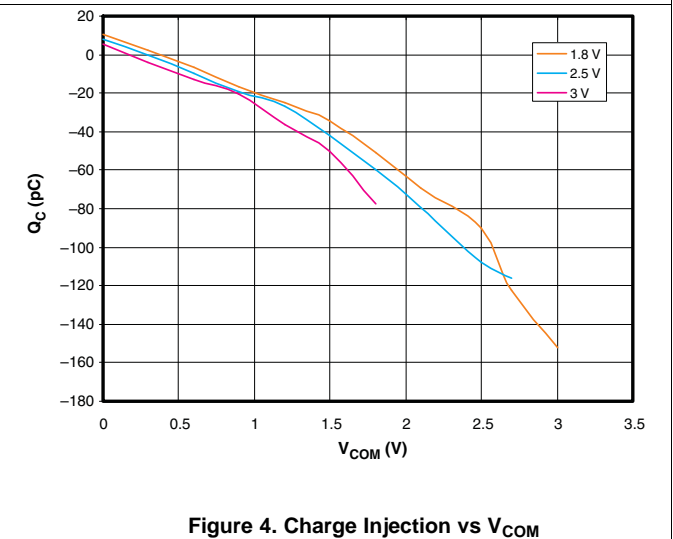
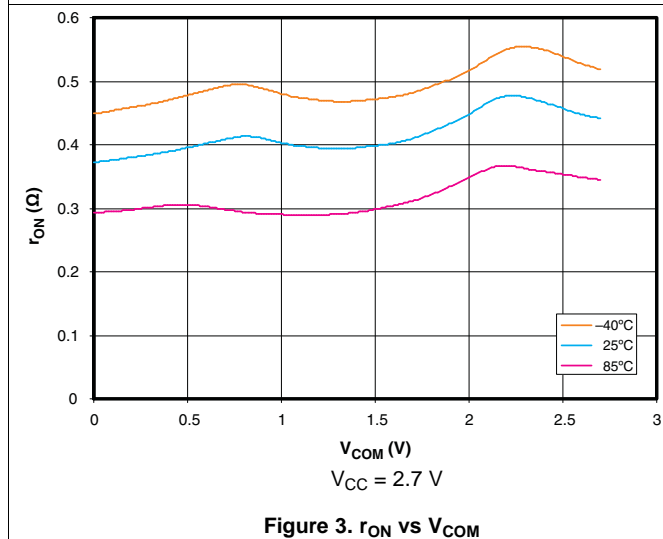
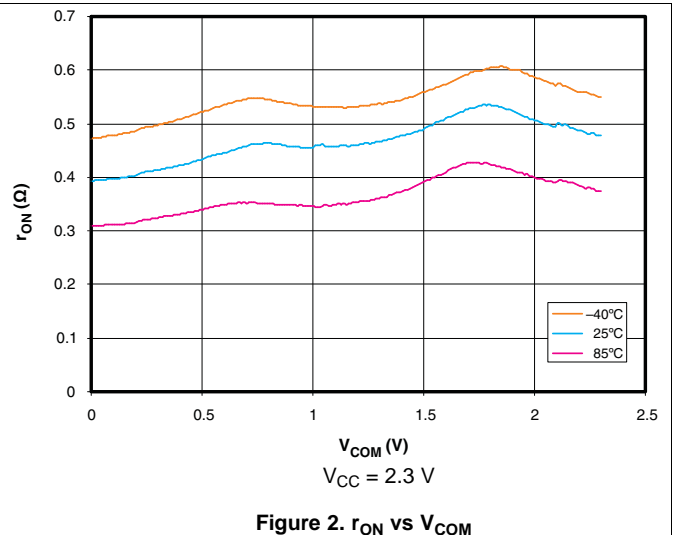
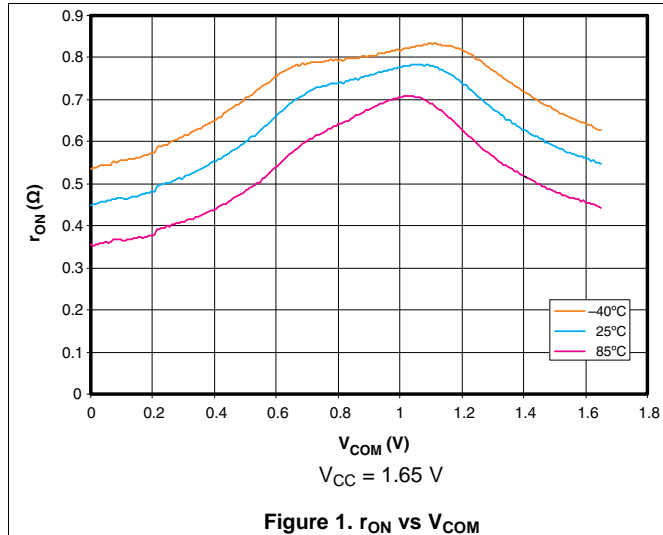

Typical Characteristics (continued)

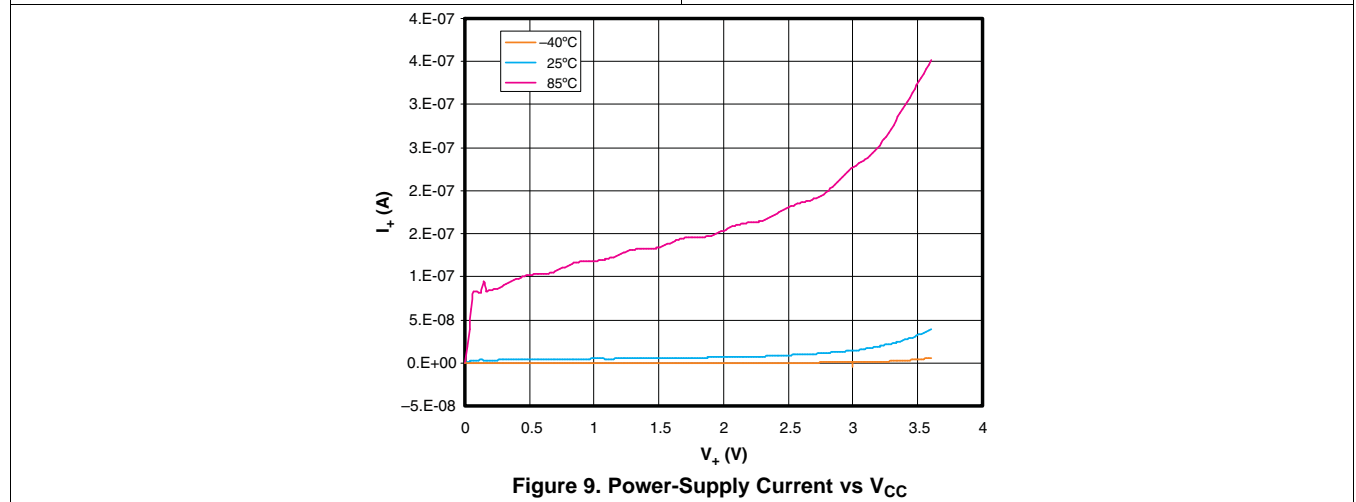
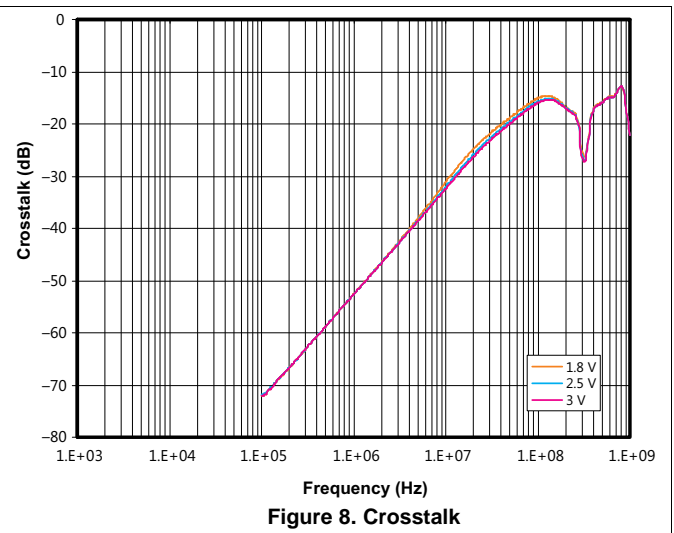
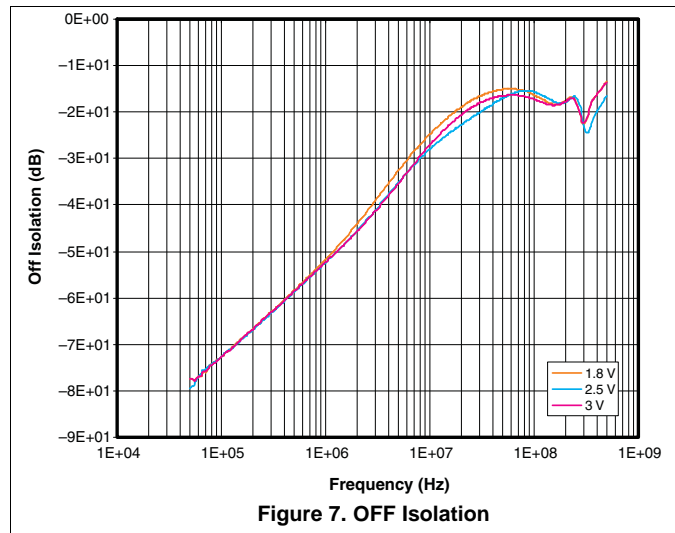

7 Parameter Measurement Information

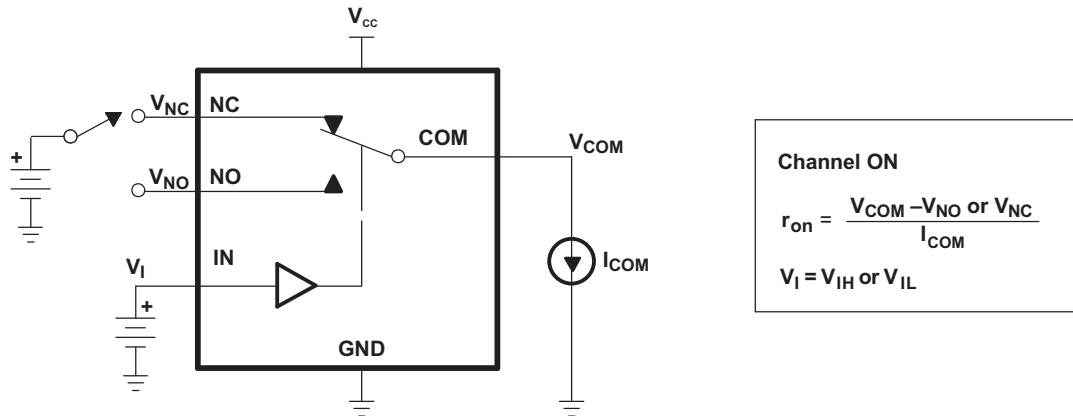
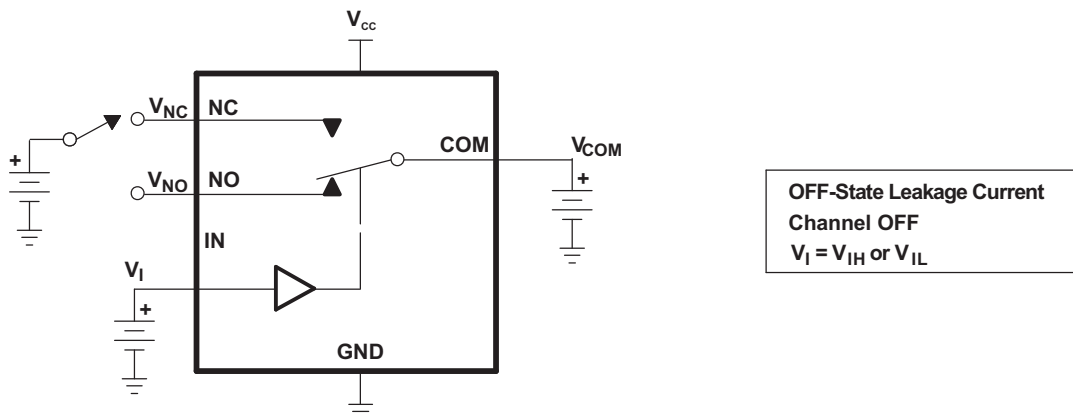
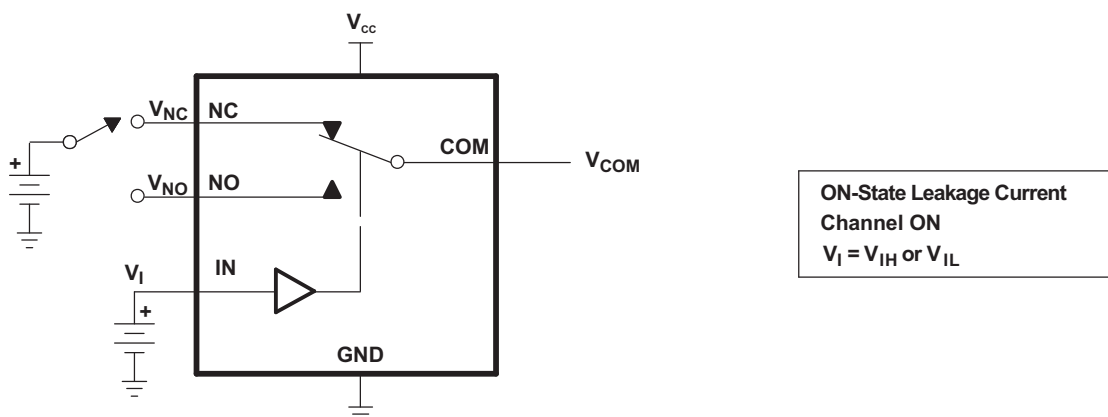

Figure 10. ON-State Resistance



$I_{NC(OFF)}$, $I_{NC(PWROFF)}$, $I_{NO(OFF)}$, $I_{NO(PWROFF)}$, $I_{COM(OFF)}$, $I_{COM(PWROFF)}$

Figure 11. OFF-State Leakage Current



$I_{COM(ON)}$, $I_{NC(ON)}$, $I_{NO(ON)}$

Figure 12. ON-State Leakage Current

Parameter Measurement Information (continued)

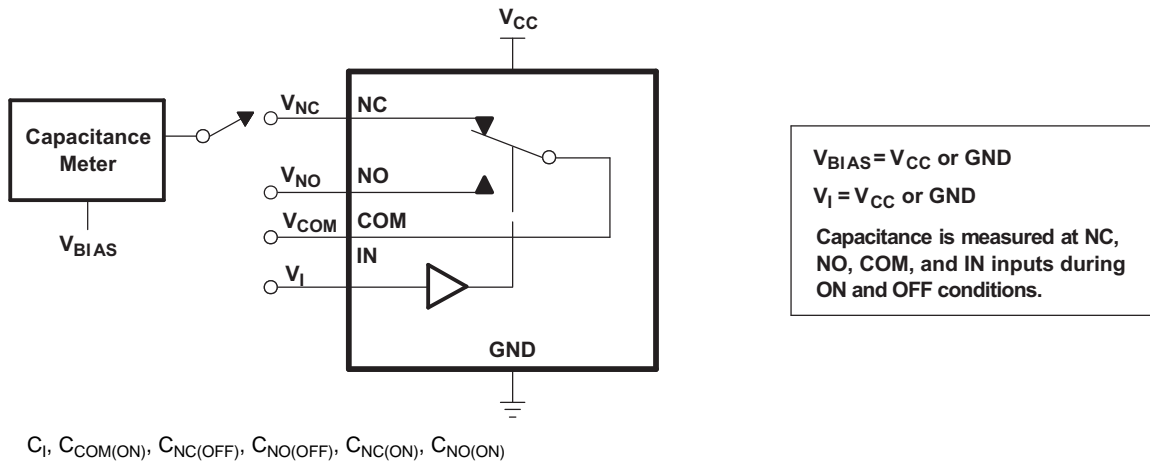
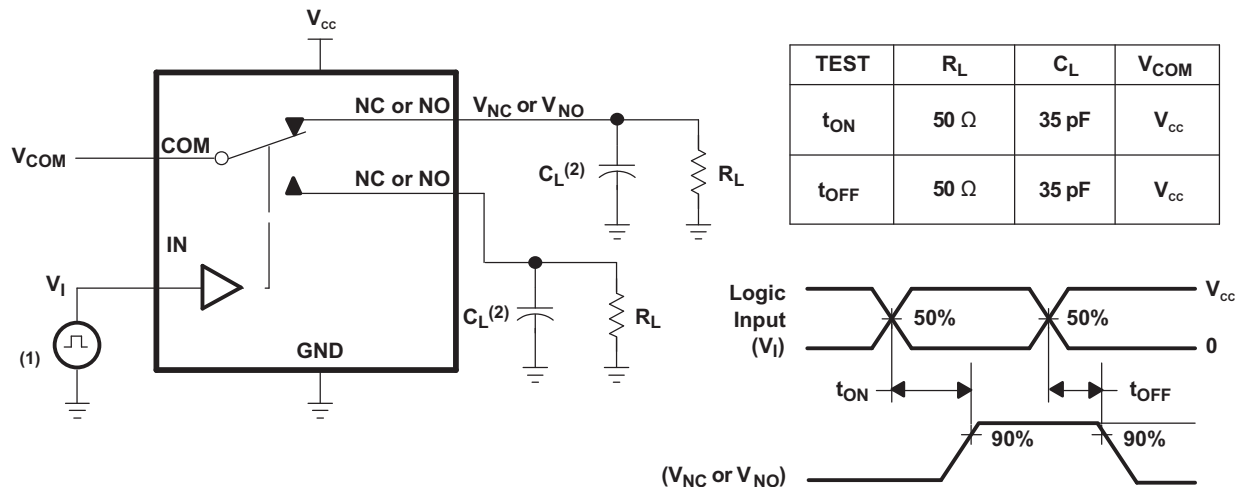

Figure 13. Capacitance



- (1) All input pulses are supplied by generators having the following characteristics:
- PRR \leq 10 MHz
 - $Z_O = 50 \Omega$
 - $t_r < 5$ ns
 - $t_f < 5$ ns
- (2) C_L includes probe and jig capacitance.

Figure 14. Turnon and Turnoff Time

Parameter Measurement Information (continued)

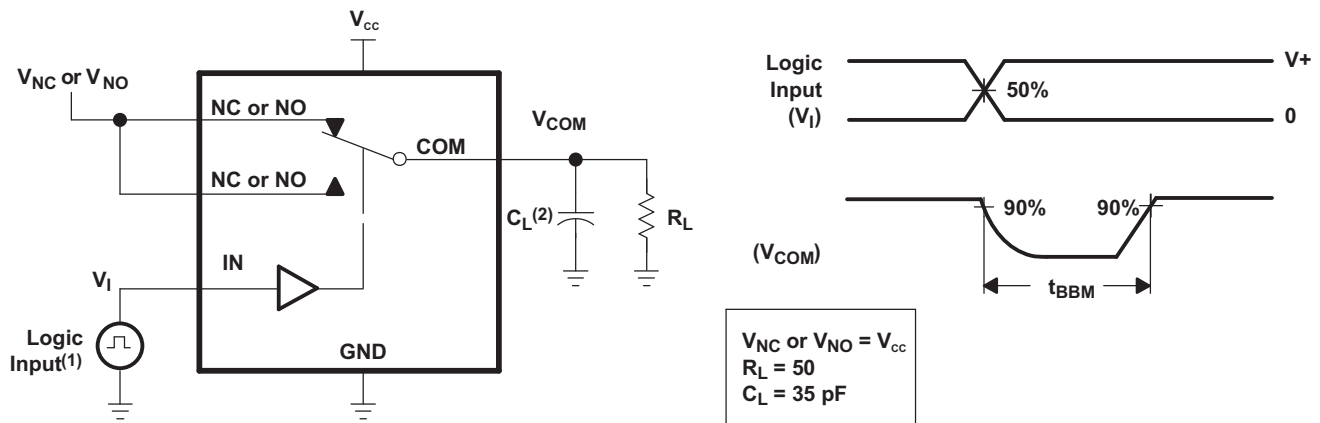

- (1) All input pulses are supplied by generators having the following characteristics:
- PRR \leq 10 MHz
 - $Z_O = 50 \Omega$
 - $t_r < 5$ ns
 - $t_f < 5$ ns
- A. C_L includes probe and jig capacitance.

Figure 15. Break-Before-Make Time

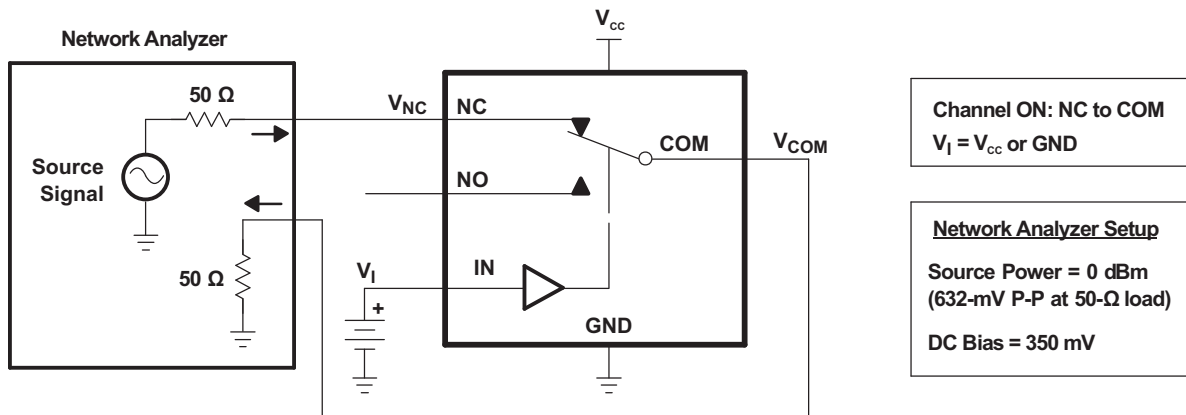

Figure 16. Bandwidth

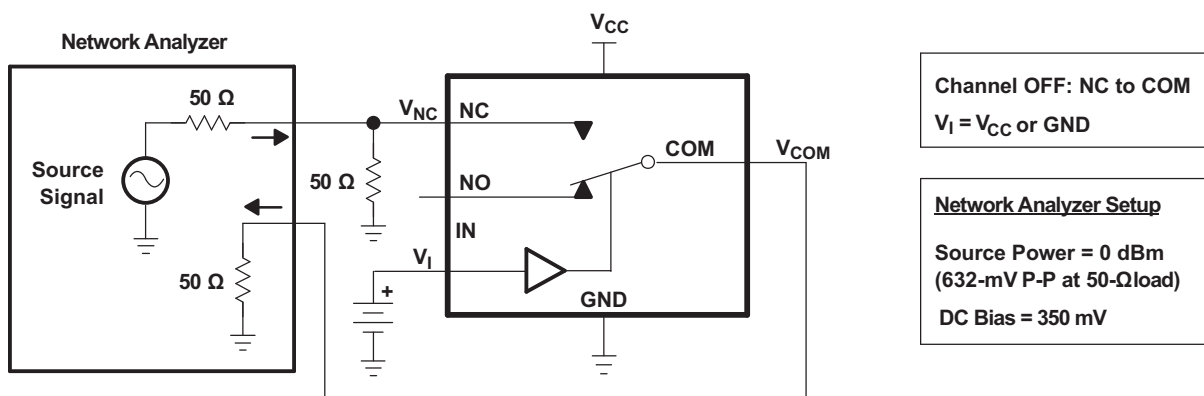

Figure 17. OFF Isolation

Parameter Measurement Information (continued)

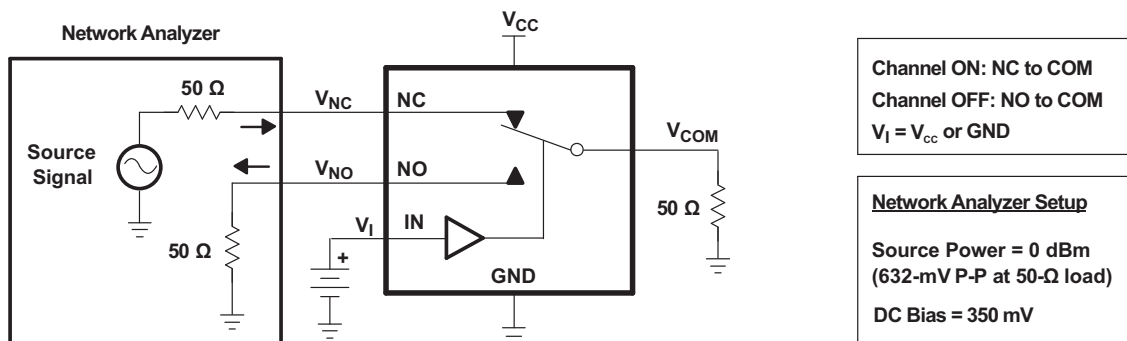
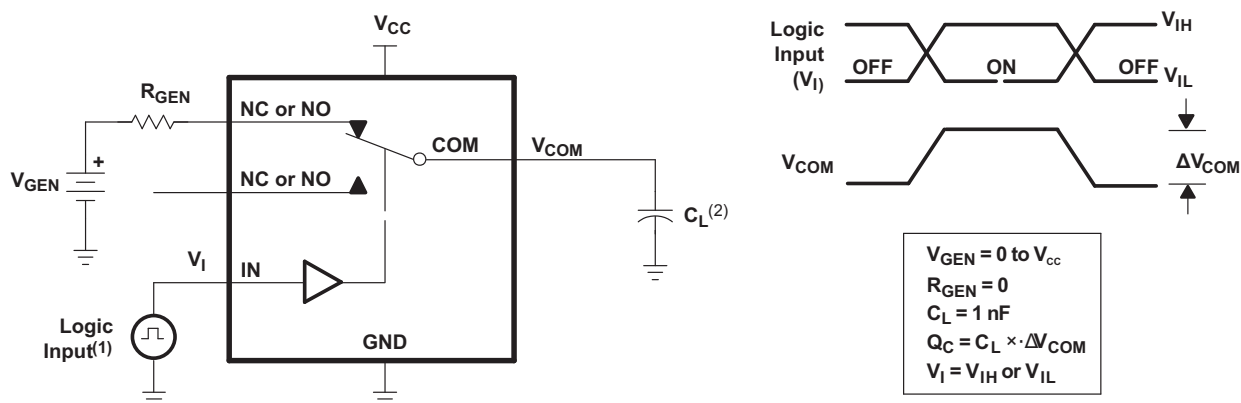

Figure 18. Crosstalk



- (1) All input pulses are supplied by generators having the following characteristics:
- PRR ≤ 10 MHz
 - $Z_O = 50 \Omega$
 - $t_r < 5 \text{ ns}$
 - $t_f < 5 \text{ ns}$
- (2) C_L includes probe and jig capacitance.

Figure 19. Charge Injection

Channel ON: COM to NO $V_I = V_{IH}$ or V_{IL} $R_L = 600 \Omega$
 $V_{SOURCE} = V_{CC} \text{ P-P}$ Source Signal = 20 Hz to 20 kHz $C_L = 50 \text{ pF}$

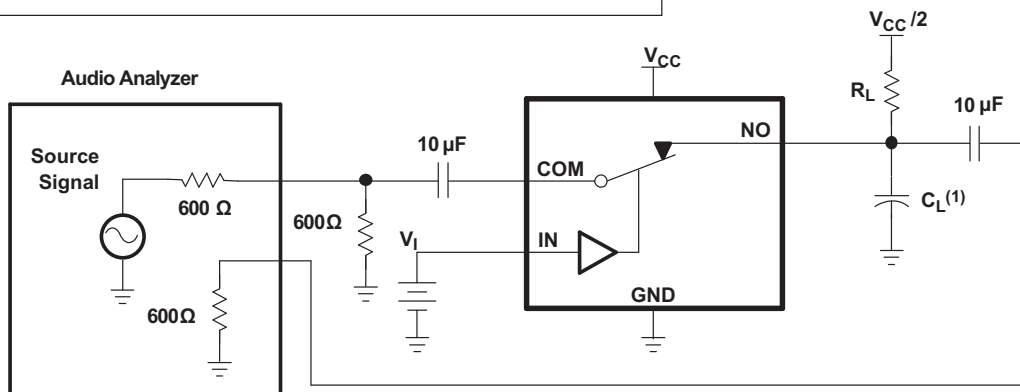

- (1) C_L includes probe and jig capacitance.

Figure 20. Total Harmonic Distortion

8 Detailed Description

8.1 Overview

The TS3A24157 is a bidirectional, 2-channel, single-pole double-throw (SPDT) analog switch. This switch offers low ON-state resistance and excellent THD performance which makes it great for interfacing with an ADC.

8.2 Functional Block Diagram

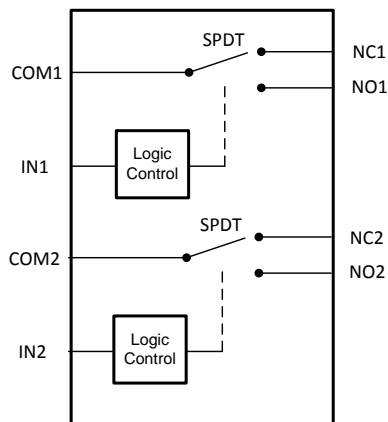

Copyright © 2016, Texas Instruments Incorporated

8.3 Feature Description

The TS3A24157 is a bidirectional device that has two single-pole, double-throw switches. The two channels of the switch are controlled independently by two digital signals; one digital control for each single-pole, doublethrow switch.

8.4 Device Functional Modes

To allow signals to pass between the NC and COM pins you must set the digital control IN pin *Low*

To allow signals to pass between the NO and COM pins you must set the digital control IN pin *High*

Table 1. Function Table

IN	NC TO COM, COM TO NC	NO TO COM, COM TO NO
L	ON	OFF
H	OFF	ON

9 Application and Implementation

NOTE

Information in the following applications sections is not part of the TI component specification, and TI does not warrant its accuracy or completeness. TI's customers are responsible for determining suitability of components for their purposes. Customers should validate and test their design implementation to confirm system functionality.

9.1 Application Information

The switches are bidirectional, so the NO, NC, and COM pins can be used as either inputs or outputs.

9.2 Typical Application

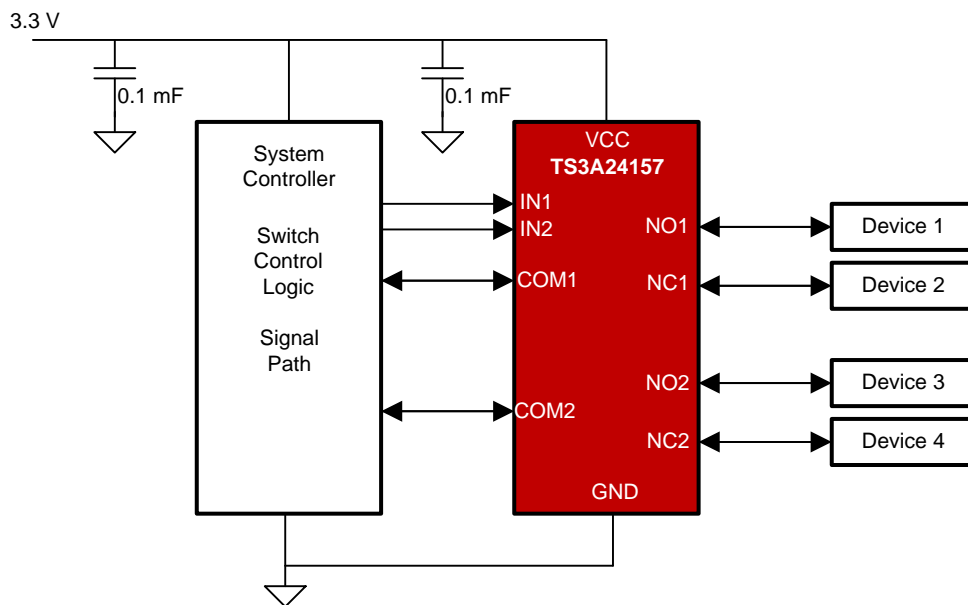

Copyright © 2016, Texas Instruments Incorporated

Figure 21. Typical Application Schematic

9.2.1 Design Requirements

The TS3A24157 can be properly operated without any external components.

When unused, pins COM, NC, and NO may be left floating.

Digital control pins IN must be pulled up to VCC or down to GND to avoid undesired switch positions that could result from the floating pin.

9.2.2 Detailed Design Procedure

Ensure that all of the signals passing through the switch are within the ranges specified in [Recommended Operating Conditions](#) to ensure proper performance.

Typical Application (continued)

9.2.3 Application Curves

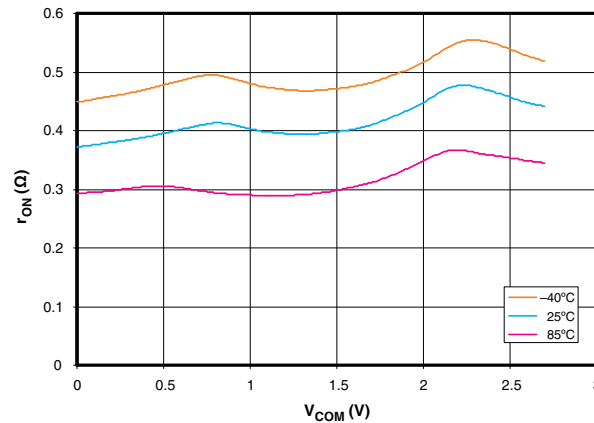

V_{CC} = 2.7 V

Figure 22. r_{ON} vs V_{COM}

10 Power Supply Recommendations

TI recommends proper power-supply sequencing for all CMOS devices. Do not exceed the absolute-maximum ratings, because stresses beyond the listed ratings can cause permanent damage to the device. Always sequence V_{CC} on first, followed by NO, NC, or COM. Although it is not required, power-supply bypassing improves noise margin and prevents switching noise propagation from the V_{CC} supply to other components. A 0.1-μF capacitor, connected from VCC to GND, is adequate for most applications

11 Layout

11.1 Layout Guidelines

High-speed switches require proper layout and design procedures for optimum performance. Reduce stray inductance and capacitance by keeping traces short and wide. Ensure that bypass capacitors are placed as close to the device as possible. Use large ground planes where possible.

11.2 Layout Example

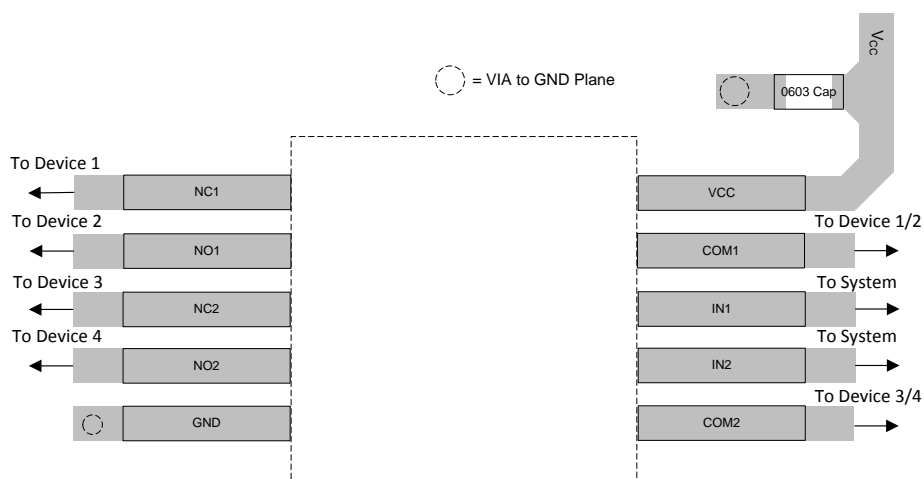

Figure 23. TS3A24157 Example Layout

12 Device and Documentation Support

12.1 Device Support

12.1.1 Device Nomenclature

V_{COM}	Voltage at COM.
V_{NC}	Voltage at NC.
V_{NO}	Voltage at NO.
r_{ON}	Resistance between COM and NC or COM and NO ports when the channel is ON.
r_{PEAK}	Peak ON-state resistance over a specified voltage range.
Δr_{ON}	Difference of r_{ON} between channels in a specific device.
$r_{ON(FLAT)}$	Difference between the maximum and minimum value of r_{ON} in a channel over the specified range of conditions.
$I_{NC(OFF)}$	Leakage current measured at the NC port, with the corresponding channel (NC to COM) in the OFF state under worst-case input and output conditions.
$I_{NC(PWROFF)}$	Leakage current measured at the NC port during the power-down condition ($V_{CC} = 0$).
$I_{NO(OFF)}$	Leakage current measured at the NO port, with the corresponding channel (NO to COM) in the OFF state under worst-case input and output conditions.
$I_{NO(PWROFF)}$	Leakage current measured at the NO port during the power-down condition ($V_{CC} = 0$).
$I_{NC(ON)}$	Leakage current measured at the NC port, with the corresponding channel (NC to COM) in the ON state and the output (COM) open.
$I_{NO(ON)}$	Leakage current measured at the NO port, with the corresponding channel (NO to COM) in the ON state and the output (COM) open.
$I_{COM(ON)}$	Leakage current measured at the COM port, with the corresponding channel (COM to NO or COM to NC) in the ON state and the output (NC or NO) open.
$I_{COM(PWROFF)}$	Leakage current measured at the COM port during the power-down condition ($V_{CC} = 0$).
V_{IH}	Minimum input voltage for logic high for the control input (IN).
V_{IL}	Maximum input voltage for logic low for the control input (IN).
V_I	Voltage at the control input (IN).
I_{IH}, I_{IL}	Leakage current measured at the control input (IN).
t_{ON}	Turnon time for the switch. This parameter is measured under the specified range of conditions and by the propagation delay between the digital control (IN) signal and analog output (COM, NC, or NO) signal when the switch is turning ON.
t_{OFF}	Turnoff time for the switch. This parameter is measured under the specified range of conditions and by the propagation delay between the digital control (IN) signal and analog output (COM, NC, or NO) signal when the switch is turning OFF.
t_{BBM}	Break-before-make time. This parameter is measured under the specified range of conditions and by the propagation delay between the output of two adjacent analog channels (NC and NO) when the control signal changes state.
Q_C	Charge injection is a measurement of unwanted signal coupling from the control (IN) input to the analog (NC, NO, or COM) output. This is measured in coulomb (C) and measured by the total charge induced due to switching of the control input. Charge injection, $Q_C = C_L \times \Delta V_{COM}$, C_L is the load capacitance and ΔV_{COM} is the change in analog output voltage.
$C_{NC(OFF)}$	Capacitance at the NC port when the corresponding channel (NC to COM) is OFF.
$C_{NO(OFF)}$	Capacitance at the NO port when the corresponding channel (NO to COM) is OFF.

Device Support (continued)

C_{NC(ON)}	Capacitance at the NC port when the corresponding channel (NC to COM) is ON.
C_{NO(ON)}	Capacitance at the NO port when the corresponding channel (NO to COM) is ON.
C_{COM(ON)}	Capacitance at the COM port when the corresponding channel (COM to NC or COM to NO) is ON.
C_I	Capacitance of control input (IN).
O_{ISO}	OFF isolation of the switch is a measurement of OFF-state switch impedance. This is measured in dB in a specific frequency, with the corresponding channel (NC to COM or NO to COM) in the OFF state.
X_{TALK}	Crosstalk is a measurement of unwanted signal coupling from an ON channel to an OFF channel (NC to NO or NO to NC). This is measured in a specific frequency and in dB.
BW	Bandwidth of the switch. This is the frequency in which the gain of an ON channel is –3 dB below the DC gain.
THD	Total harmonic distortion describes the signal distortion caused by the analog switch. This is defined as the ratio of root mean square (RMS) value of the second, third, and higher harmonic to the absolute magnitude of the fundamental harmonic.
I_{CC}	Static power-supply current with the control (IN) pin at V _{CC} or GND.

12.2 Documentation Support

12.2.1 Related Documentation

For related documentation see the following:

[Implications of Slow or Floating CMOS Inputs](#) (SCBA004)

12.3 Receiving Notification of Documentation Updates

To receive notification of documentation updates, navigate to the device product folder on ti.com. In the upper right corner, click on *Alert me* to register and receive a weekly digest of any product information that has changed. For change details, review the revision history included in any revised document.

12.4 Community Resources

The following links connect to TI community resources. Linked contents are provided "AS IS" by the respective contributors. They do not constitute TI specifications and do not necessarily reflect TI's views; see TI's [Terms of Use](#).

TI E2E™ Online Community *TI's Engineer-to-Engineer (E2E) Community*. Created to foster collaboration among engineers. At e2e.ti.com, you can ask questions, share knowledge, explore ideas and help solve problems with fellow engineers.

Design Support *TI's Design Support* Quickly find helpful E2E forums along with design support tools and contact information for technical support.

12.5 Trademarks

E2E is a trademark of Texas Instruments.
All other trademarks are the property of their respective owners.

12.6 Electrostatic Discharge Caution



These devices have limited built-in ESD protection. The leads should be shorted together or the device placed in conductive foam during storage or handling to prevent electrostatic damage to the MOS gates.

12.7 Glossary

SLYZ022 — *TI Glossary*.

This glossary lists and explains terms, acronyms, and definitions.

13 Mechanical, Packaging, and Orderable Information

The following pages include mechanical, packaging, and orderable information. This information is the most current data available for the designated devices. This data is subject to change without notice and revision of this document. For browser-based versions of this data sheet, refer to the left-hand navigation.

PACKAGING INFORMATION

Orderable Device	Status (1)	Package Type	Package Drawing	Pins	Package Qty	Eco Plan (2)	Lead finish/ Ball material (6)	MSL Peak Temp (3)	Op Temp (°C)	Device Marking (4/5)	Samples
TS3A24157DGSR	ACTIVE	VSSOP	DGS	10	2500	RoHS & Green	NIPDAU	Level-1-260C-UNLIM	-40 to 85	(JZO, JZR)	Samples
TS3A24157RSER	ACTIVE	UQFN	RSE	10	3000	RoHS & Green	NIPDAU	Level-1-260C-UNLIM	-40 to 85	JZO	Samples
TS3A24157RSEGR4	ACTIVE	UQFN	RSE	10	3000	RoHS & Green	NIPDAU	Level-1-260C-UNLIM	-40 to 85	JZO	Samples

(1) The marketing status values are defined as follows:

ACTIVE: Product device recommended for new designs.

LIFEBUY: TI has announced that the device will be discontinued, and a lifetime-buy period is in effect.

NRND: Not recommended for new designs. Device is in production to support existing customers, but TI does not recommend using this part in a new design.

PREVIEW: Device has been announced but is not in production. Samples may or may not be available.

OBSELETE: TI has discontinued the production of the device.

(2) **RoHS:** TI defines "RoHS" to mean semiconductor products that are compliant with the current EU RoHS requirements for all 10 RoHS substances, including the requirement that RoHS substance do not exceed 0.1% by weight in homogeneous materials. Where designed to be soldered at high temperatures, "RoHS" products are suitable for use in specified lead-free processes. TI may reference these types of products as "Pb-Free".

RoHS Exempt: TI defines "RoHS Exempt" to mean products that contain lead but are compliant with EU RoHS pursuant to a specific EU RoHS exemption.

Green: TI defines "Green" to mean the content of Chlorine (Cl) and Bromine (Br) based flame retardants meet JS709B low halogen requirements of <=1000ppm threshold. Antimony trioxide based flame retardants must also meet the <=1000ppm threshold requirement.

(3) MSL, Peak Temp. - The Moisture Sensitivity Level rating according to the JEDEC industry standard classifications, and peak solder temperature.

(4) There may be additional marking, which relates to the logo, the lot trace code information, or the environmental category on the device.

(5) Multiple Device Markings will be inside parentheses. Only one Device Marking contained in parentheses and separated by a "~" will appear on a device. If a line is indented then it is a continuation of the previous line and the two combined represent the entire Device Marking for that device.

(6) Lead finish/Ball material - Orderable Devices may have multiple material finish options. Finish options are separated by a vertical ruled line. Lead finish/Ball material values may wrap to two lines if the finish value exceeds the maximum column width.

Important Information and Disclaimer:The information provided on this page represents TI's knowledge and belief as of the date that it is provided. TI bases its knowledge and belief on information provided by third parties, and makes no representation or warranty as to the accuracy of such information. Efforts are underway to better integrate information from third parties. TI has taken and continues to take reasonable steps to provide representative and accurate information but may not have conducted destructive testing or chemical analysis on incoming materials and chemicals. TI and TI suppliers consider certain information to be proprietary, and thus CAS numbers and other limited information may not be available for release.

In no event shall TI's liability arising out of such information exceed the total purchase price of the TI part(s) at issue in this document sold by TI to Customer on an annual basis.

TAPE AND REEL INFORMATION



QUADRANT ASSIGNMENTS FOR PIN 1 ORIENTATION IN TAPE



*All dimensions are nominal

Device	Package Type	Package Drawing	Pins	SPQ	Reel Diameter (mm)	Reel Width W1 (mm)	A0 (mm)	B0 (mm)	K0 (mm)	P1 (mm)	W (mm)	Pin1 Quadrant
TS3A24157DGSR	VSSOP	DGS	10	2500	330.0	12.4	5.3	3.3	1.3	8.0	12.0	Q1
TS3A24157RSER	UQFN	RSE	10	3000	179.0	8.4	1.75	2.25	0.65	4.0	8.0	Q1

TAPE AND REEL BOX DIMENSIONS

*All dimensions are nominal

Device	Package Type	Package Drawing	Pins	SPQ	Length (mm)	Width (mm)	Height (mm)
TS3A24157DGSR	VSSOP	DGS	10	2500	346.0	346.0	35.0
TS3A24157RSER	UQFN	RSE	10	3000	200.0	183.0	25.0

DGS0010A

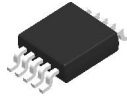

PACKAGE OUTLINE

VSSOP - 1.1 mm max height

SMALL OUTLINE PACKAGE

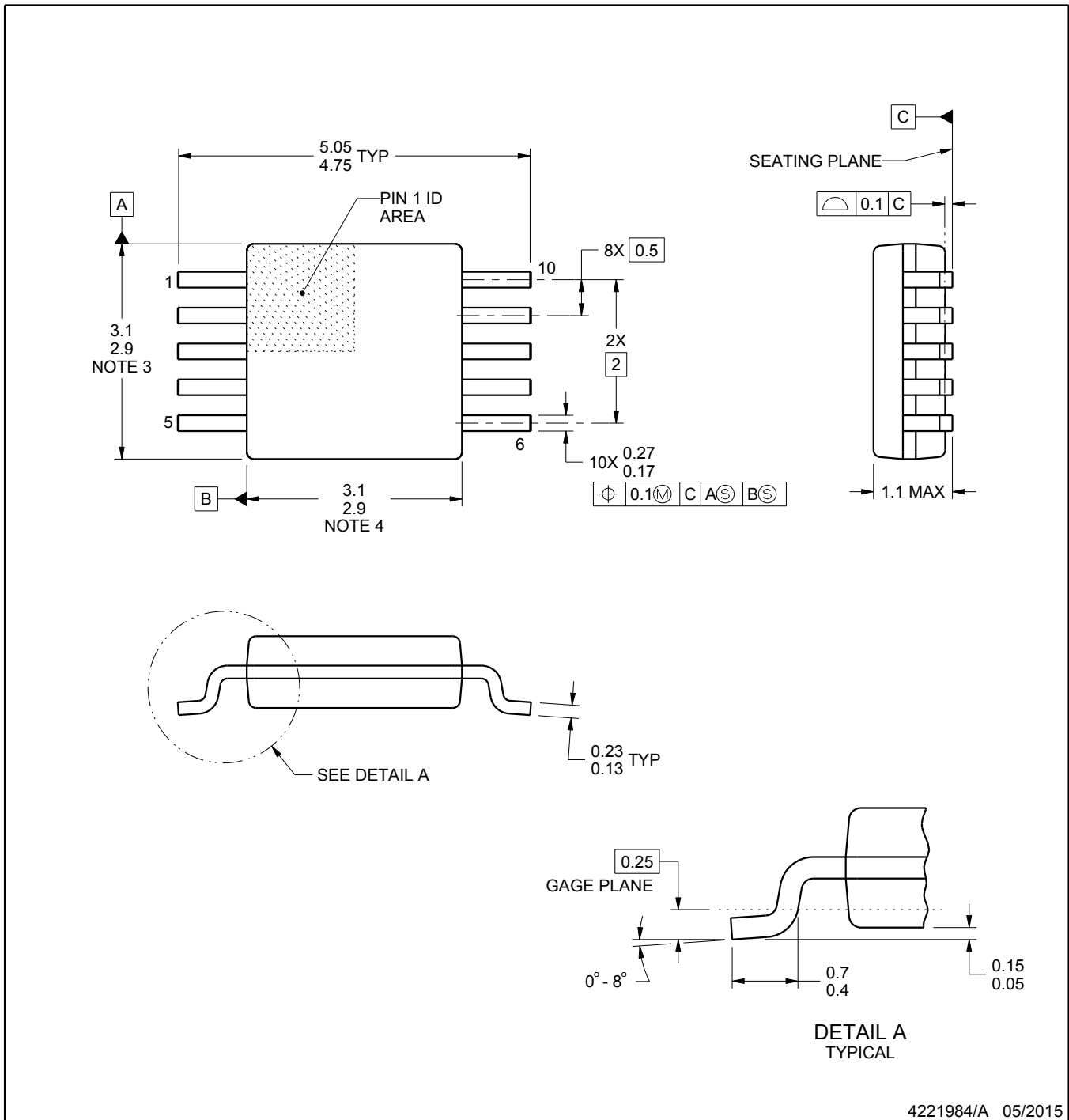

4221984/A 05/2015

NOTES:

1. All linear dimensions are in millimeters. Any dimensions in parenthesis are for reference only. Dimensioning and tolerancing per ASME Y14.5M.
2. This drawing is subject to change without notice.
3. This dimension does not include mold flash, protrusions, or gate burrs. Mold flash, protrusions, or gate burrs shall not exceed 0.15 mm per side.
4. This dimension does not include interlead flash. Interlead flash shall not exceed 0.25 mm per side.
5. Reference JEDEC registration MO-187, variation BA.

EXAMPLE BOARD LAYOUT

DGS0010A

VSSOP - 1.1 mm max height

SMALL OUTLINE PACKAGE



LAND PATTERN EXAMPLE
SCALE:10X

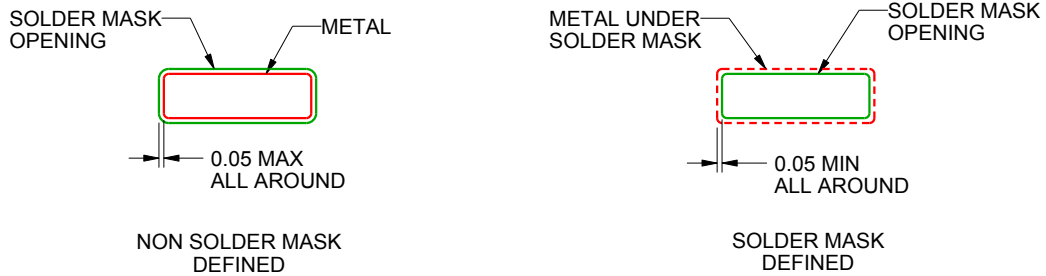

SOLDER MASK DETAILS
NOT TO SCALE

4221984/A 05/2015

NOTES: (continued)

- 6. Publication IPC-7351 may have alternate designs.
- 7. Solder mask tolerances between and around signal pads can vary based on board fabrication site.

EXAMPLE STENCIL DESIGN

DGS0010A

VSSOP - 1.1 mm max height

SMALL OUTLINE PACKAGE



SOLDER PASTE EXAMPLE
BASED ON 0.125 mm THICK STENCIL
SCALE:10X

4221984/A 05/2015

NOTES: (continued)

8. Laser cutting apertures with trapezoidal walls and rounded corners may offer better paste release. IPC-7525 may have alternate design recommendations.
9. Board assembly site may have different recommendations for stencil design.

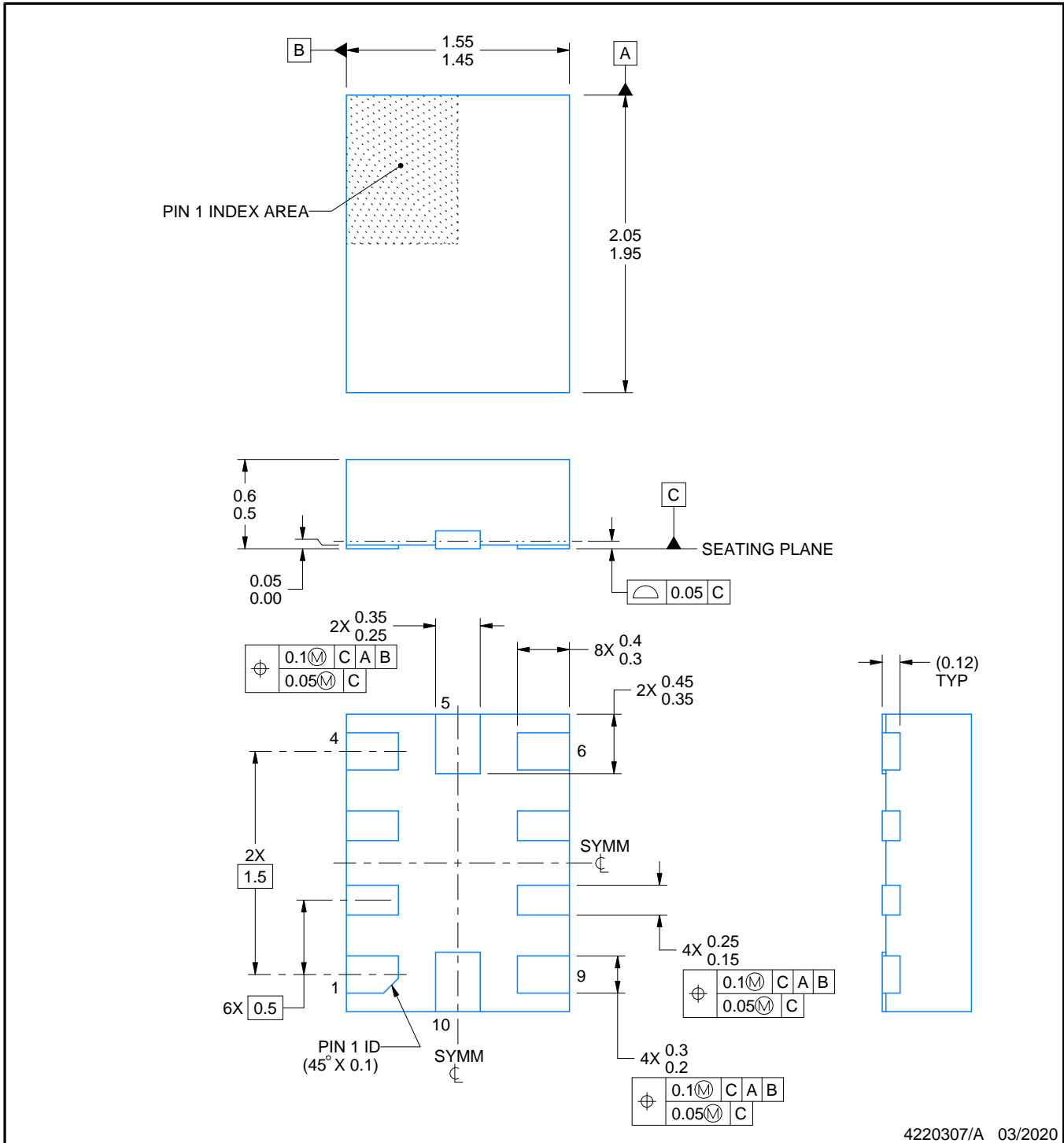
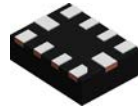

NOTES:

1. All linear dimensions are in millimeters. Any dimensions in parenthesis are for reference only. Dimensioning and tolerancing per ASME Y14.5M.
2. This drawing is subject to change without notice.

EXAMPLE BOARD LAYOUT

RSE0010A

UQFN - 0.6 mm max height

PLASTIC QUAD FLATPACK - NO LEAD

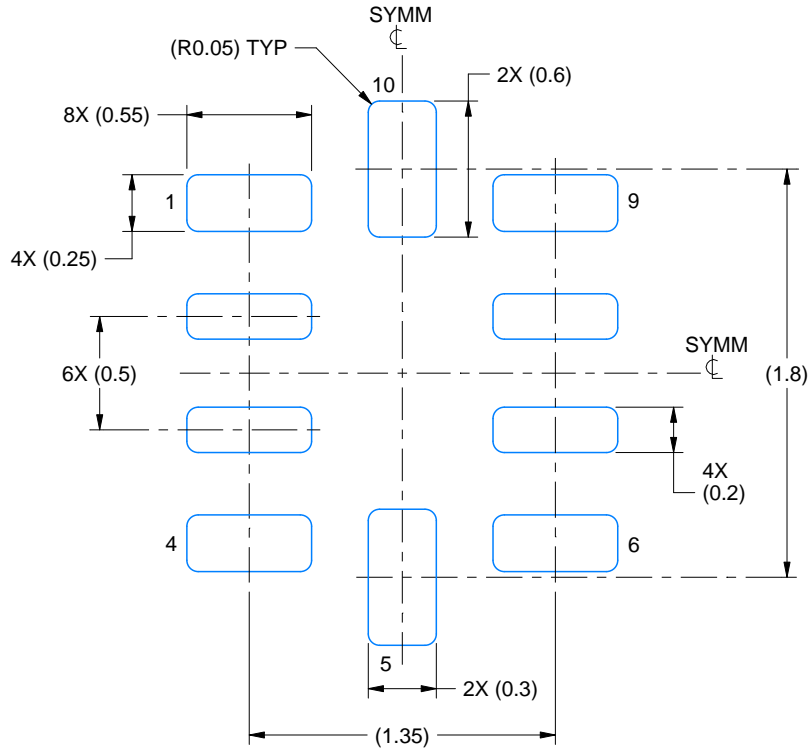

LAND PATTERN EXAMPLE
EXPOSED METAL SHOWN
SCALE:30X

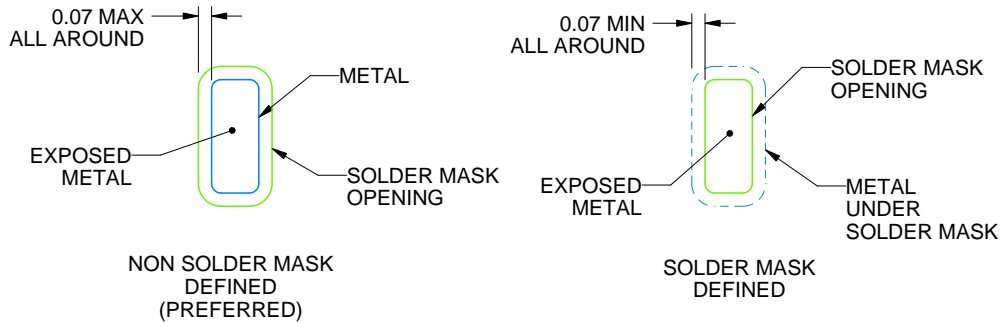

SOLDER MASK DETAILS
NOT TO SCALE

4220307/A 03/2020

NOTES: (continued)

3. For more information, see Texas Instruments literature number SLUA271 (www.ti.com/lit/slua271).

EXAMPLE STENCIL DESIGN

RSE0010A

UQFN - 0.6 mm max height

PLASTIC QUAD FLATPACK - NO LEAD

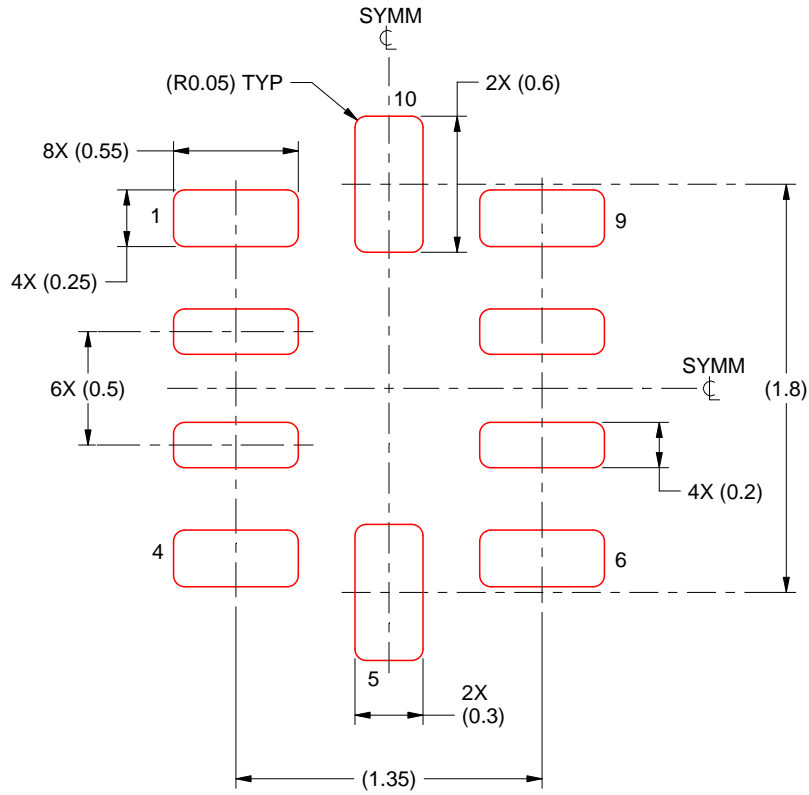

SOLDER PASTE EXAMPLE
BASED ON 0.1 mm THICKNESS
SCALE: 30X

4220307/A 03/2020

NOTES: (continued)

5. Laser cutting apertures with trapezoidal walls and rounded corners may offer better paste release. IPC-7525 may have alternate design recommendations.

IMPORTANT NOTICE AND DISCLAIMER

TI PROVIDES TECHNICAL AND RELIABILITY DATA (INCLUDING DATASHEETS), DESIGN RESOURCES (INCLUDING REFERENCE DESIGNS), APPLICATION OR OTHER DESIGN ADVICE, WEB TOOLS, SAFETY INFORMATION, AND OTHER RESOURCES "AS IS" AND WITH ALL FAULTS, AND DISCLAIMS ALL WARRANTIES, EXPRESS AND IMPLIED, INCLUDING WITHOUT LIMITATION ANY IMPLIED WARRANTIES OF MERCHANTABILITY, FITNESS FOR A PARTICULAR PURPOSE OR NON-INFRINGEMENT OF THIRD PARTY INTELLECTUAL PROPERTY RIGHTS.

These resources are intended for skilled developers designing with TI products. You are solely responsible for (1) selecting the appropriate TI products for your application, (2) designing, validating and testing your application, and (3) ensuring your application meets applicable standards, and any other safety, security, or other requirements. These resources are subject to change without notice. TI grants you permission to use these resources only for development of an application that uses the TI products described in the resource. Other reproduction and display of these resources is prohibited. No license is granted to any other TI intellectual property right or to any third party intellectual property right. TI disclaims responsibility for, and you will fully indemnify TI and its representatives against, any claims, damages, costs, losses, and liabilities arising out of your use of these resources.

TI's products are provided subject to TI's Terms of Sale (<https://www.ti.com/legal/termsofsale.html>) or other applicable terms available either on [ti.com](https://www.ti.com) or provided in conjunction with such TI products. TI's provision of these resources does not expand or otherwise alter TI's applicable warranties or warranty disclaimers for TI products.

Mailing Address: Texas Instruments, Post Office Box 655303, Dallas, Texas 75265
Copyright © 2021, Texas Instruments Incorporated