

## LMV71x-N Low-Power, RRIO Operational Amplifiers With High Output Current Drive and Shutdown Option

### 1 Features

- Low Offset Voltage: 3 mV (Maximum)
- Gain-Bandwidth Product: 5 MHz (Typical)
- Slew Rate: 5 V/ $\mu$ s (Typical)
- Space-Saving Packages: 5-Pin and 6-Pin SOT-23
- Turnon Time From Shutdown: <10  $\mu$ s
- Industrial Temperature Range:  $-40^{\circ}\text{C}$  to  $85^{\circ}\text{C}$
- Supply Current in Shutdown Mode: 0.2  $\mu$ A (Typical)
- Ensured 2.7-V and 5-V Performance
- Unity Gain Stable
- Rail-to-Rail Input and Output
- Capable of Driving 600- $\Omega$  Load

### 2 Applications

- Wireless Phones
- GSM, TDMA, and CDMA Power Amp Controls
- AGC and RF Power Detectors
- Temperature Compensation
- Wireless LAN
- Bluetooth
- HomeRF

### 3 Description

The LMV710-N, LMV711-N, and LMV715-N are BiCMOS operational amplifiers with a CMOS input stage. These devices have greater than RR input common mode voltage range, rail-to-rail output and high output current drive. They offer a bandwidth of 5 MHz and a slew rate of 5 V/ $\mu$ s.

On the LMV711 and LMV715, a separate shutdown pin can be used to disable the device and reduces the supply current to 0.2  $\mu$ A (typical). They also feature a turnon time of less than 10  $\mu$ s. It is an ideal solution for power-sensitive applications, such as cellular phone, pager, palm computer, and so forth. In addition, once the LMV715 is in shutdown the output is tri-stated.

The LMV710 is offered in the space-saving, 5-pin SOT-23 package. The LMV711 and LMV715 are offered in the space saving 6-pin SOT-23 package.

The LMV71x-N devices are designed to meet the demands of low power, low cost, and small size required by cellular phones and similar battery-powered portable electronics.

#### Device Information<sup>(1)</sup>

PART NUMBER	PACKAGE	BODY SIZE (NOM)
LMV710-N	SOT-23 (5)	2.92 mm x 1.50 mm
LMV711-N LMV715-N	SOT-23 (6)	2.92 mm x 1.50 mm

(1) For all available packages, see the orderable addendum at the end of the data sheet.

#### Simplified Schematic – LMV711

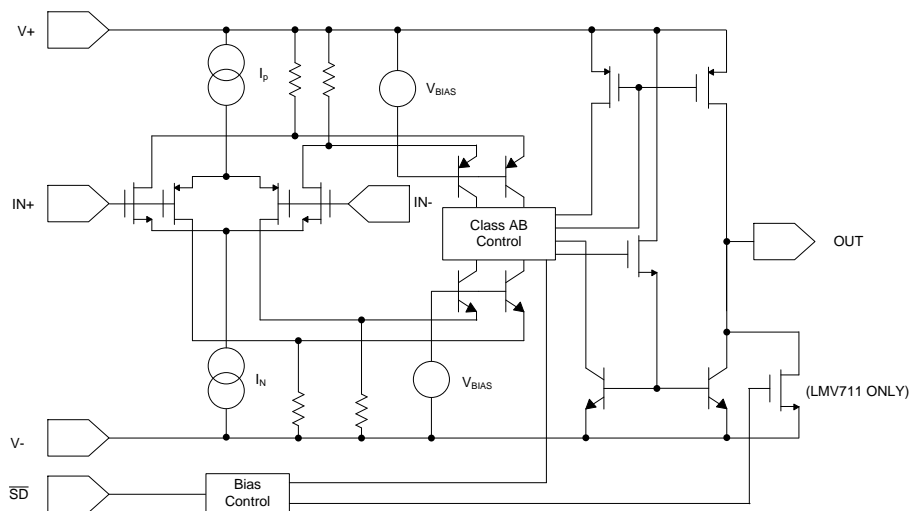

Copyright © 2016, Texas Instruments Incorporated



## Table of Contents

<b>1 Features</b> .....	<b>1</b>	7.4 Device Functional Modes .....	<b>16</b>
<b>2 Applications</b> .....	<b>1</b>	<b>8 Application and Implementation</b> .....	<b>19</b>
<b>3 Description</b> .....	<b>1</b>	8.1 Application Information.....	<b>19</b>
<b>4 Revision History</b> .....	<b>2</b>	8.2 Typical Applications .....	<b>19</b>
<b>5 Pin Configuration and Functions</b> .....	<b>3</b>	<b>9 Power Supply Recommendations</b> .....	<b>22</b>
<b>6 Specifications</b> .....	<b>4</b>	<b>10 Layout</b> .....	<b>22</b>
6.1 Absolute Maximum Ratings .....	<b>4</b>	10.1 Layout Guidelines .....	<b>22</b>
6.2 ESD Ratings.....	<b>4</b>	10.2 Layout Example .....	<b>22</b>
6.3 Recommended Operating Conditions.....	<b>4</b>	<b>11 Device and Documentation Support</b> .....	<b>23</b>
6.4 Thermal Information .....	<b>4</b>	11.1 Device Support .....	<b>23</b>
6.5 Electrical Characteristics – 2.7 V .....	<b>5</b>	11.2 Documentation Support .....	<b>23</b>
6.6 Electrical Characteristics – 3.2 V .....	<b>6</b>	11.3 Related Links .....	<b>23</b>
6.7 Electrical Characteristics – 5 V .....	<b>6</b>	11.4 Receiving Notification of Documentation Updates	<b>23</b>
6.8 Typical Characteristics .....	<b>8</b>	11.5 Community Resources.....	<b>23</b>
<b>7 Detailed Description</b> .....	<b>14</b>	11.6 Trademarks .....	<b>23</b>
7.1 Overview .....	<b>14</b>	11.7 Electrostatic Discharge Caution.....	<b>24</b>
7.2 Functional Block Diagram .....	<b>14</b>	11.8 Glossary .....	<b>24</b>
7.3 Feature Description .....	<b>14</b>	<b>12 Mechanical, Packaging, and Orderable Information</b> .....	<b>24</b>

## 4 Revision History

NOTE: Page numbers for previous revisions may differ from page numbers in the current version.

### Changes from Revision J (March 2013) to Revision K

Page

- Added *ESD Ratings* table, *Feature Description* section, *Device Functional Modes*, *Application and Implementation* section, *Power Supply Recommendations* section, *Layout* section, *Device and Documentation Support* section, and *Mechanical, Packaging, and Orderable Information* section .....

**1**

## 5 Pin Configuration and Functions

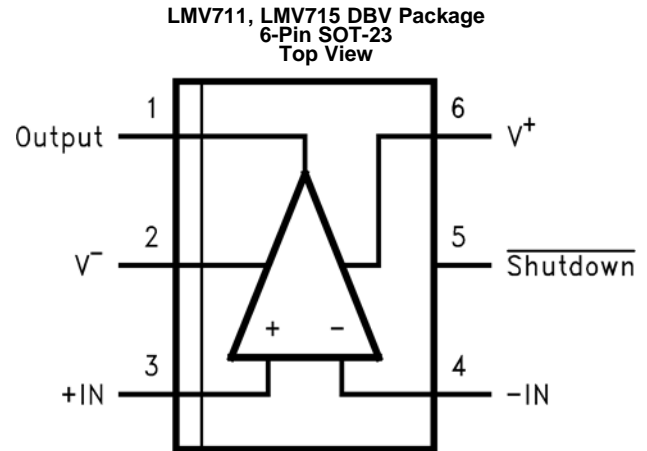
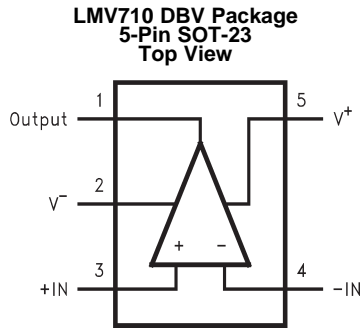

### Pin Functions

NAME	PIN		TYPE <sup>(1)</sup>	DESCRIPTION
	DBV (5)	DBV (6)		
+IN	3	3	I	Noninverting input
-IN	4	4	I	Inverting input
Output	1	1	O	Output
$\overline{\text{Shutdown}}$	—	5	I	Active low enable input
V <sup>+</sup>	5	6	P	Positive supply input
V <sup>-</sup>	2	2	P	Supply negative input

(1) I = Input, O = Output, P = Power

## 6 Specifications

### 6.1 Absolute Maximum Ratings

 over operating free-air temperature range (unless otherwise noted)<sup>(1)(2)</sup>

	MIN	MAX	UNIT
Differential input voltage	±Supply voltage		
Voltage at input or output pin	(V <sup>-</sup> ) - 0.4	(V <sup>+</sup> ) + 0.4	V
Supply voltage (V <sup>+</sup> - V <sup>-</sup> )	5.5		V
Output short circuit to V <sup>+</sup>	See <sup>(3)</sup>		
Output short circuit to V <sup>-</sup>	See <sup>(4)</sup>		
Current at input pin	±10		mA
Mounting temperature, infrared or convection (20 sec)	235		°C
Junction temperature, T <sub>J(MAX)</sub> <sup>(5)</sup>	150		°C
Storage temperature, T <sub>stg</sub>	-65	150	°C

- Stresses beyond those listed under *Absolute Maximum Ratings* may cause permanent damage to the device. These are stress ratings only, which do not imply functional operation of the device at these or any other conditions beyond those indicated under *Recommended Operating Conditions*. Exposure to absolute-maximum-rated conditions for extended periods may affect device reliability.
- If Military/Aerospace specified devices are required, please contact the Texas Instruments Sales Office/ Distributors for availability and specifications.
- Shorting circuit output to V<sup>+</sup> will adversely affect reliability.
- Shorting circuit output to V<sup>-</sup> will adversely affect reliability.
- The maximum power dissipation is a function of T<sub>J(MAX)</sub>, R<sub>θJA</sub>, and T<sub>A</sub>. The maximum allowable power dissipation at any ambient temperature is P<sub>D</sub> = (T<sub>J(MAX)</sub> - T<sub>A</sub>) / R<sub>θJA</sub>. All numbers apply for packages soldered directly into a PCB.

### 6.2 ESD Ratings

		VALUE	UNIT
V <sub>(ESD)</sub> Electrostatic discharge	Human-body model (HBM) <sup>(1)(2)</sup>	±2000	V
	Machine model (MM) <sup>(3)</sup>	±100	

- JEDEC document JEP155 states that 500-V HBM allows safe manufacturing with a standard ESD control process.
- Human-body model, 1.5 kΩ in series with 100 pF.
- Machine model, 0 Ω in series with 100 pF.

### 6.3 Recommended Operating Conditions

over operating free-air temperature range (unless otherwise noted)

	MIN	MAX	UNIT
Supply voltage	2.7	5	V
Temperature	-40	85	°C

### 6.4 Thermal Information

THERMAL METRIC <sup>(1)</sup>		LMV710-N	LMV711-N	LMV715-N	UNIT
		DBV (SOT-23)	DBV (SOT-23)	DBV (SOT-23)	
		5 PINS	6 PINS	6 PINS	
R <sub>θJA</sub>	Junction-to-ambient thermal resistance	265	265	265	°C/W
R <sub>θJC(top)</sub>	Junction-to-case (top) thermal resistance	131.6	139	156.6	°C/W
R <sub>θJB</sub>	Junction-to-board thermal resistance	35.1	38.5	32.8	°C/W
ψ <sub>JT</sub>	Junction-to-top characterization parameter	22.2	28.6	34	°C/W
ψ <sub>JB</sub>	Junction-to-board characterization parameter	34.5	37.9	32.2	°C/W
R <sub>θJC(bot)</sub>	Junction-to-case (bottom) thermal resistance	—	—	—	°C/W

- For more information about traditional and new thermal metrics, see the [Semiconductor and IC Package Thermal Metrics](#) application report.

## 6.5 Electrical Characteristics – 2.7 V

 $T_J = 25^\circ\text{C}$ ,  $V^+ = 2.7\text{ V}$ ,  $V^- = 0\text{ V}$ ,  $V_{CM} = 1.35\text{ V}$ , and  $R_L > 1\text{ M}\Omega$  (unless otherwise noted)

PARAMETER		TEST CONDITIONS		MIN <sup>(1)</sup>	TYP <sup>(2)</sup>	MAX <sup>(1)</sup>	UNIT
$V_{OS}$	Input offset voltage	$V_{CM} = 0.85\text{ V}$ and $V_{CM} = 1.85\text{ V}$	$T_J = 25^\circ\text{C}$	0.4	3	mV	
			$T_J = -40^\circ\text{C}$ to $85^\circ\text{C}$		3.2		
$I_B$	Input bias current			4		pA	
CMRR	Common-mode rejection ratio	$0\text{ V} \leq V_{CM} \leq 2.7\text{ V}$	$T_J = 25^\circ\text{C}$	50	75	dB	
			$T_J = -40^\circ\text{C}$ to $85^\circ\text{C}$	45			
PSRR	Power supply rejection ratio	$2.7\text{ V} \leq V^+ \leq 5\text{ V}$ , $V_{CM} = 0.85\text{ V}$	$T_J = 25^\circ\text{C}$	70	110	dB	
			$T_J = -40^\circ\text{C}$ to $85^\circ\text{C}$	68			
		$2.7\text{ V} \leq V^+ \leq 5\text{ V}$ , $V_{CM} = 1.85\text{ V}$	$T_J = 25^\circ\text{C}$	70	95		
			$T_J = -40^\circ\text{C}$ to $85^\circ\text{C}$	68			
$V_{CM}$	Input common-mode voltage range	For CMRR $\geq 50\text{ dB}$	V–	–0.2	–0.3	V	
			V+		3		2.9
$I_{SC}$	Output short-circuit current	Sourcing, $V_O = 0\text{ V}$	$T_J = 25^\circ\text{C}$	15	28	mA	
			$T_J = -40^\circ\text{C}$ to $85^\circ\text{C}$	12			
		Sinking, $V_O = 2.7\text{ V}$	$T_J = 25^\circ\text{C}$	25	40		
			$T_J = -40^\circ\text{C}$ to $85^\circ\text{C}$	22			
$V_O$	Output swing	$R_L = 10\text{ k}\Omega$ to $1.35\text{ V}$ VID = $100\text{ mV}$	$T_J = 25^\circ\text{C}$	2.62	2.68	V	
			$T_J = -40^\circ\text{C}$ to $85^\circ\text{C}$	2.6			
		$R_L = 10\text{ k}\Omega$ to $1.35\text{ V}$ VID = $-100\text{ mV}$	$T_J = 25^\circ\text{C}$		0.01		0.12
			$T_J = -40^\circ\text{C}$ to $85^\circ\text{C}$				0.15
		$R_L = 600\ \Omega$ to $1.35\text{ V}$ VID = $100\text{ mV}$	$T_J = 25^\circ\text{C}$	2.52	2.55		
			$T_J = -40^\circ\text{C}$ to $85^\circ\text{C}$	2.5			
		$R_L = 600\ \Omega$ to $1.35\text{ V}$ VID = $-100\text{ mV}$	$T_J = 25^\circ\text{C}$		0.05		0.23
			$T_J = -40^\circ\text{C}$ to $85^\circ\text{C}$				0.3
$V_{O(SD)}$	Output voltage level in shutdown mode	LMV711 only		50	200	mV	
$I_{O(SD)}$	Output leakage current in shutdown mode	LMV715 only		1		pA	
$C_{O(SD)}$	Output capacitance in shutdown mode	LMV715 only		32		pF	
$I_S$	Supply current	ON mode	$T_J = 25^\circ\text{C}$	1.22	1.7	mA	
			$T_J = -40^\circ\text{C}$ to $85^\circ\text{C}$		1.9		
		Shutdown mode, $V_{SD} = 0\text{ V}$		0.002	10	$\mu\text{A}$	
$A_V$	Large signal voltage	Sourcing, $R_L = 10\text{ k}\Omega$ , $V_O = 1.35\text{ V}$ to $2.3\text{ V}$	$T_J = 25^\circ\text{C}$	80	115	dB	
			$T_J = -40^\circ\text{C}$ to $85^\circ\text{C}$	76			
		Sinking, $R_L = 10\text{ k}\Omega$ , $V_O = 0.4\text{ V}$ to $1.35\text{ V}$	$T_J = 25^\circ\text{C}$	80	113		
			$T_J = -40^\circ\text{C}$ to $85^\circ\text{C}$	76			
		Sourcing, $R_L = 600\ \Omega$ , $V_O = 1.35\text{ V}$ to $2.2\text{ V}$	$T_J = 25^\circ\text{C}$	80	110		
			$T_J = -40^\circ\text{C}$ to $85^\circ\text{C}$	76			
		Sinking, $R_L = 600\ \Omega$ , $V_O = 0.5\text{ V}$ to $1.35\text{ V}$	$T_J = 25^\circ\text{C}$	80	100		
			$T_J = -40^\circ\text{C}$ to $85^\circ\text{C}$	76			
SR	Slew rate <sup>(3)</sup>			5		V/ $\mu\text{s}$	
GBWP	Gain-bandwidth product			5		MHz	
$\phi_m$	Phase margin			60		$^\circ$	
$T_{ON}$	Turnon time from shutdown			<10		$\mu\text{s}$	

(1) All limits are specified by testing or statistical analysis.

(2) Typical values represent the most likely parametric norm.

(3) Number specified is the slower of the positive and negative slew rates.

## Electrical Characteristics – 2.7 V (continued)

 $T_J = 25^\circ\text{C}$ ,  $V^+ = 2.7\text{ V}$ ,  $V^- = 0\text{ V}$ ,  $V_{CM} = 1.35\text{ V}$ , and  $R_L > 1\text{ M}\Omega$  (unless otherwise noted)

PARAMETER		TEST CONDITIONS	MIN <sup>(1)</sup>	TYP <sup>(2)</sup>	MAX <sup>(1)</sup>	UNIT
$V_{SD}$	Shutdown pin voltage range	ON mode	2.4	1.5	2.7	V
		Shutdown mode	0	1	0.8	
$e_n$	Input-referred voltage noise	$f = 1\text{ kHz}$		20		nV/ $\sqrt{\text{Hz}}$

## 6.6 Electrical Characteristics – 3.2 V

 $T_J = 25^\circ\text{C}$ ,  $V^+ = 3.2\text{ V}$ ,  $V^- = 0\text{ V}$ , and  $V_{CM} = 1.6\text{ V}$  (unless otherwise noted)

PARAMETER		TEST CONDITIONS	MIN <sup>(1)</sup>	TYP <sup>(2)</sup>	MAX <sup>(1)</sup>	UNIT
$V_O$	Output Swing	$I_O = 6.5\text{ mA}$	$T_J = 25^\circ\text{C}$	2.95	3	V
			$T_J = -40^\circ\text{C to } 85^\circ\text{C}$	2.92		
		$T_J = 25^\circ\text{C}$		0.01	0.18	
		$T_J = -40^\circ\text{C to } 85^\circ\text{C}$			0.25	

(1) All limits are specified by testing or statistical analysis.

(2) Typical values represent the most likely parametric norm.

## 6.7 Electrical Characteristics – 5 V

 $T_J = 25^\circ\text{C}$ ,  $V^+ = 5\text{ V}$ ,  $V^- = 0\text{ V}$ ,  $V_{CM} = 2.5\text{ V}$ , and  $R_L > 1\text{ M}\Omega$  (unless otherwise noted)

PARAMETER		TEST CONDITIONS	MIN <sup>(1)</sup>	TYP <sup>(2)</sup>	MAX <sup>(1)</sup>	UNIT	
$V_{OS}$	Input offset voltage	$V_{CM} = 0.85\text{ V and } V_{CM} = 1.85\text{ V}$	$T_J = 25^\circ\text{C}$	0.4	3	mV	
			$T_J = -40^\circ\text{C to } 85^\circ\text{C}$		3.2		
$I_B$	Input bias current			4		pA	
CMRR	Common-mode rejection ratio	$0\text{ V} \leq V_{CM} \leq 5\text{ V}$	$T_J = 25^\circ\text{C}$	50	70	dB	
			$T_J = -40^\circ\text{C to } 85^\circ\text{C}$	48			
PSRR	Power supply rejection ratio	$2.7\text{ V} \leq V^+ \leq 5\text{ V}, V_{CM} = 0.85\text{ V}$	$T_J = 25^\circ\text{C}$	70	110	dB	
			$T_J = -40^\circ\text{C to } 85^\circ\text{C}$	68			
		$2.7\text{ V} \leq V^+ \leq 5\text{ V}, V_{CM} = 1.85\text{ V}$	$T_J = 25^\circ\text{C}$	70	95		
			$T_J = -40^\circ\text{C to } 85^\circ\text{C}$	68			
$V_{CM}$	Input common-mode voltage range	For CMRR $\geq 50\text{ dB}$	$V^-$	-0.2	-0.3	V	
			$V^+$		5.3		5.2
$I_{SC}$	Output short-circuit current	Sourcing, $V_O = 0\text{ V}$	$T_J = 25^\circ\text{C}$	25	35	mA	
			$T_J = -40^\circ\text{C to } 85^\circ\text{C}$	21			
		Sinking, $V_O = 5\text{ V}$	$T_J = 25^\circ\text{C}$	25	40		
			$T_J = -40^\circ\text{C to } 85^\circ\text{C}$	21			
$V_O$	Output swing	$R_L = 10\text{ k}\Omega\text{ to } 2.5\text{ V}$ $VID = 100\text{ mV}$	$T_J = 25^\circ\text{C}$	4.92	4.98	V	
			$T_J = -40^\circ\text{C to } 85^\circ\text{C}$	4.9			
		$R_L = 10\text{ k}\Omega\text{ to } 2.5\text{ V}$ $VID = -100\text{ mV}$	$T_J = 25^\circ\text{C}$		0.01		0.12
			$T_J = -40^\circ\text{C to } 85^\circ\text{C}$				0.15
		$R_L = 600\ \Omega\text{ to } 2.5\text{ V}$ $VID = 100\text{ mV}$	$T_J = 25^\circ\text{C}$	4.82	4.85		
			$T_J = -40^\circ\text{C to } 85^\circ\text{C}$	4.8			
		$R_L = 600\ \Omega\text{ to } 2.5\text{ V}$ $VID = -100\text{ mV}$	$T_J = 25^\circ\text{C}$		0.05		0.23
			$T_J = -40^\circ\text{C to } 85^\circ\text{C}$				0.3
$V_{O(SD)}$	Output voltage level in shutdown mode	LMV711 only		50	200	mV	
$I_{O(SD)}$	Output leakage current in shutdown mode	LMV715 only		1		pA	

(1) All limits are specified by testing or statistical analysis.

(2) Typical values represent the most likely parametric norm.

**Electrical Characteristics – 5 V (continued)**
 $T_J = 25^\circ\text{C}$ ,  $V^+ = 5\text{ V}$ ,  $V^- = 0\text{ V}$ ,  $V_{CM} = 2.5\text{ V}$ , and  $R_L > 1\text{ M}\Omega$  (unless otherwise noted)

PARAMETER		TEST CONDITIONS		MIN <sup>(1)</sup>	TYP <sup>(2)</sup>	MAX <sup>(1)</sup>	UNIT
$C_{O(SD)}$	Output capacitance in shutdown mode	LMV715 only		32			pF
$I_S$	Supply current	ON mode	$T_J = 25^\circ\text{C}$	1.17	1.7		mA
			$T_J = -40^\circ\text{C to } 85^\circ\text{C}$	1.9			
		Shutdown mode		0.2	10		$\mu\text{A}$
$A_V$	Large signal voltage gain	Sourcing, $R_L = 10\text{ k}\Omega$ , $V_O = 2.5\text{ V to } 4.6\text{ V}$	$T_J = 25^\circ\text{C}$	80	123		dB
			$T_J = -40^\circ\text{C to } 85^\circ\text{C}$	76			
		Sinking, $R_L = 10\text{ k}\Omega$ , $V_O = 0.4\text{ V to } 2.5\text{ V}$	$T_J = 25^\circ\text{C}$	80	120		
			$T_J = -40^\circ\text{C to } 85^\circ\text{C}$	76			
		Sourcing, $R_L = 600\ \Omega$ , $V_O = 2.5\text{ V to } 4.5\text{ V}$	$T_J = 25^\circ\text{C}$	80	110		
			$T_J = -40^\circ\text{C to } 85^\circ\text{C}$	76			
Sinking, $R_L = 600\ \Omega$ , $V_O = 0.5\text{ V to } 2.5\text{ V}$	$T_J = 25^\circ\text{C}$	80	118				
	$T_J = -40^\circ\text{C to } 85^\circ\text{C}$	76					
SR	Slew rate <sup>(3)</sup>			5			$\text{V}/\mu\text{s}$
GBWP	Gain-bandwidth product			5			MHz
$\phi_m$	Phase margin			60			°
$T_{ON}$	Turnon time from shutdown			<10			$\mu\text{s}$
$V_{SD}$	Shutdown pin voltage range	ON mode		2.4	2	5	V
		Shutdown mode		0	1.5	0.8	
$e_n$	Input-referred voltage noise	$f = 1\text{ kHz}$		20			$\text{nV}/\sqrt{\text{Hz}}$

(3) Number specified is the slower of the positive and negative slew rates.

## 6.8 Typical Characteristics

$V_S = 5\text{ V}$ , single supply,  $T_A = 25^\circ\text{C}$  (unless otherwise noted)

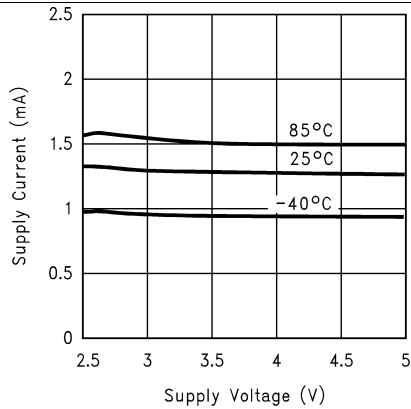

Figure 1. Supply Current vs Supply Voltage (ON Mode)

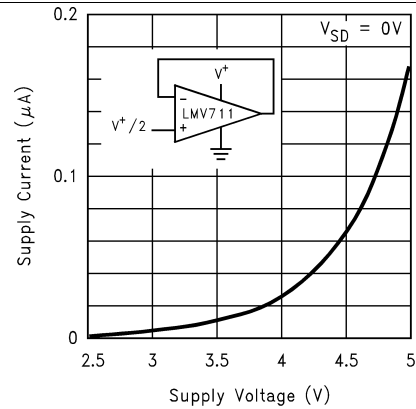

Figure 2. LMV711, LMV715 Supply Current vs Supply Voltage (Shutdown Mode)

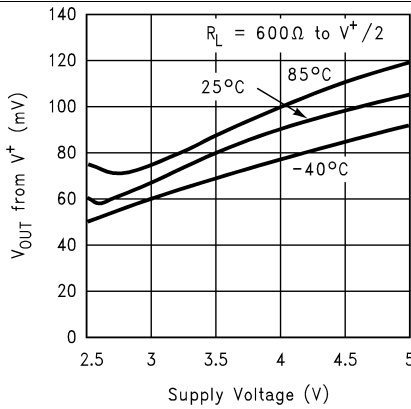

Figure 3. Output Positive Swing vs Supply Voltage

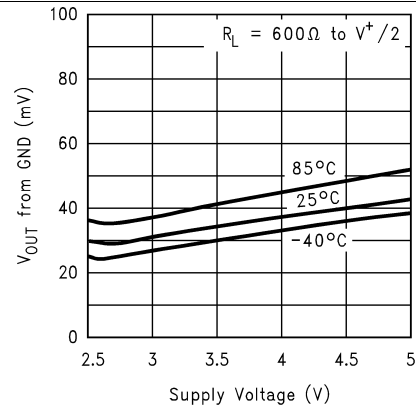

Figure 4. Output Negative Swing vs Supply Voltage

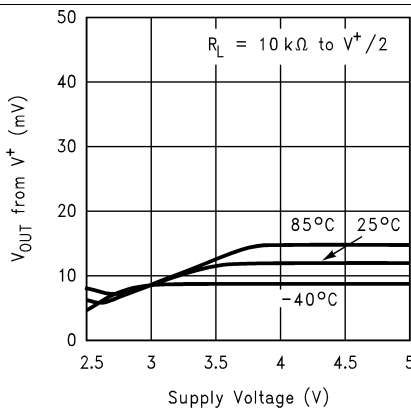

Figure 5. Output Positive Swing vs Supply Voltage

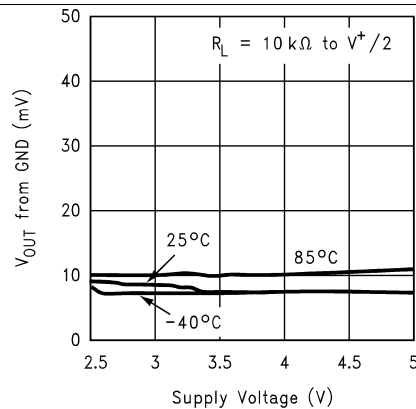
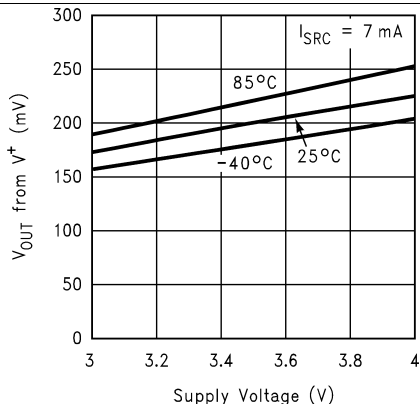

Figure 6. Output Negative Swing vs Supply Voltage

**Typical Characteristics (continued)**

$V_S = 5\text{ V}$ , single supply,  $T_A = 25^\circ\text{C}$  (unless otherwise noted)



**Figure 7. Output Positive Swing vs Supply Voltage**

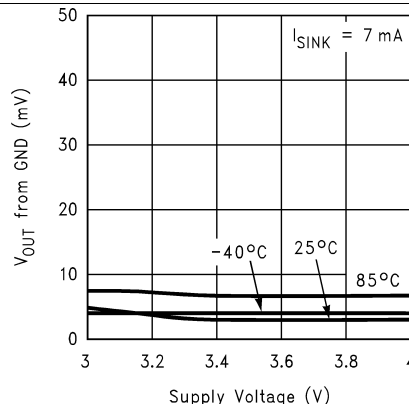

**Figure 8. Output Negative Swing vs Supply Voltage**

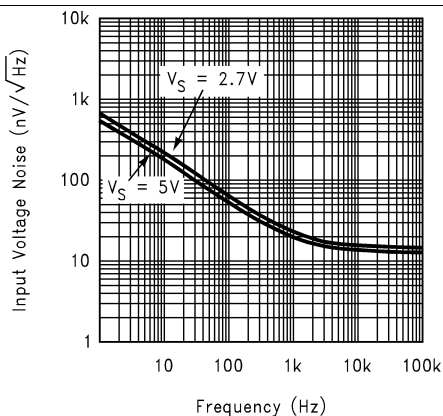

**Figure 9. Input Voltage Noise vs Frequency**

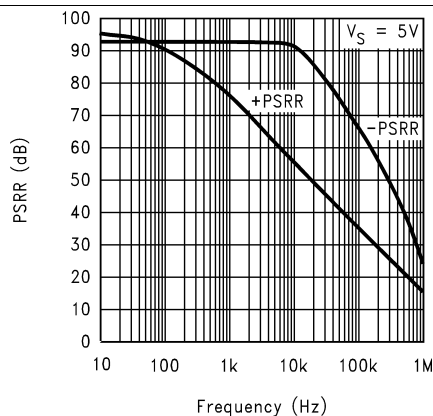

**Figure 10. PSRR vs Frequency**

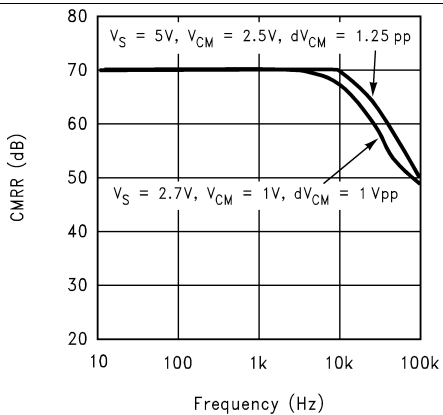

**Figure 11. CMRR vs Frequency**

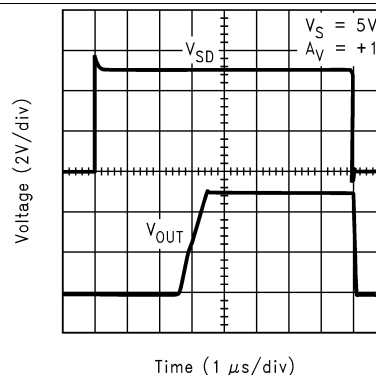

**Figure 12. LMV711 and LMV715 Turnon Characteristics**

Typical Characteristics (continued)

$V_S = 5\text{ V}$ , single supply,  $T_A = 25^\circ\text{C}$  (unless otherwise noted)

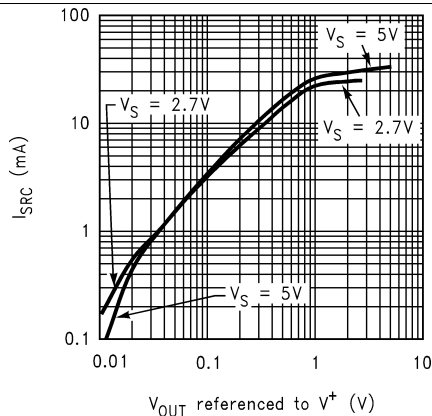

Figure 13. Sourcing Current vs Output Voltage

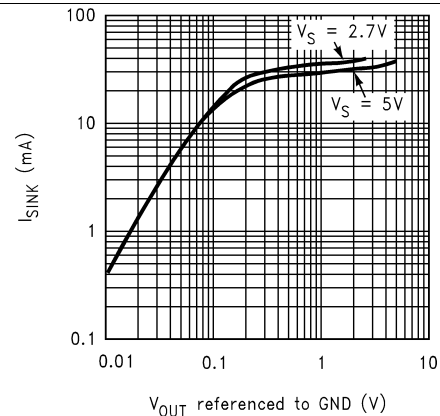

Figure 14. Sinking Current vs Output Voltage

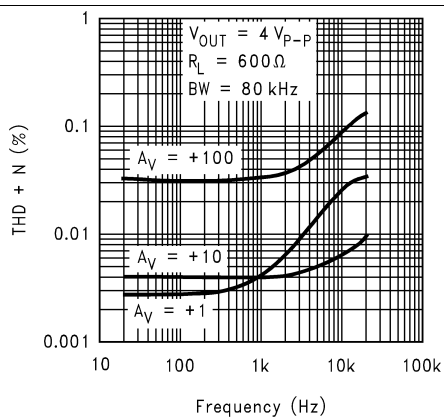

Figure 15. Thd+N vs Frequency ( $V_S = 5\text{ V}$ )

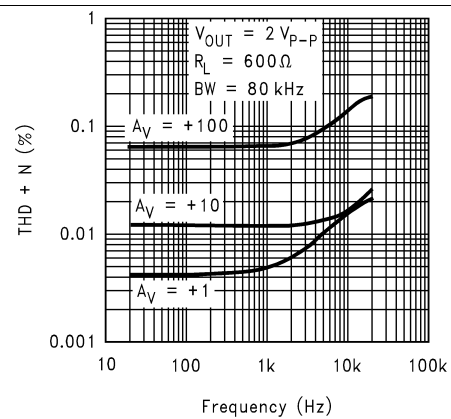

Figure 16. Thd+N vs Frequency ( $V_S = 2.7\text{ V}$ )

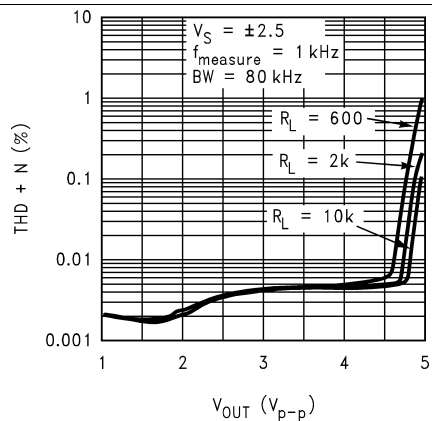

Figure 17. Thd+N vs  $V_{OUT}$

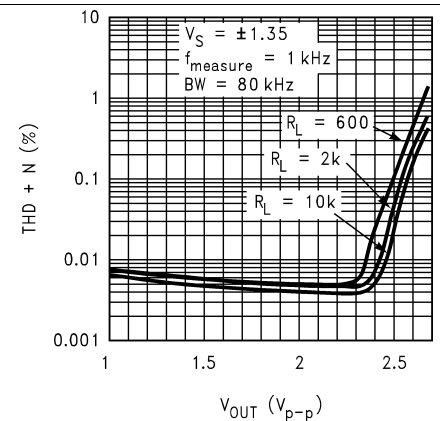

Figure 18. Thd+N vs  $V_{OUT}$

Typical Characteristics (continued)

$V_S = 5\text{ V}$ , single supply,  $T_A = 25^\circ\text{C}$  (unless otherwise noted)

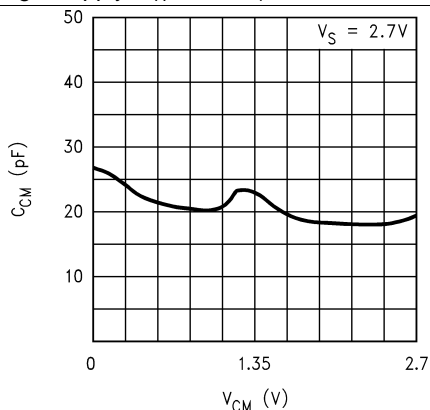

Figure 19.  $C_{CM}$  vs  $V_{CM}$

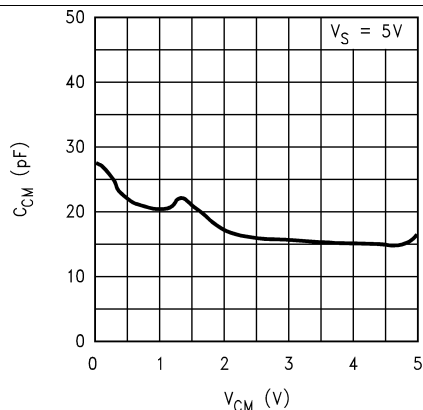

Figure 20.  $C_{CM}$  vs  $V_{CM}$

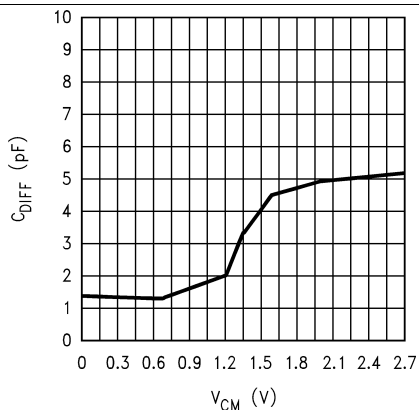

Figure 21.  $C_{DIFF}$  vs  $V_{CM}$  ( $V_S = 2.7\text{ V}$ )

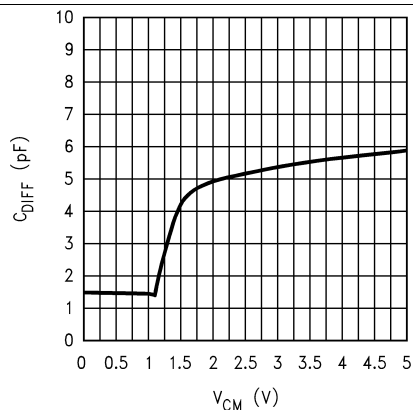

Figure 22.  $C_{DIFF}$  vs  $V_{CM}$  ( $V_S = 5\text{ V}$ )

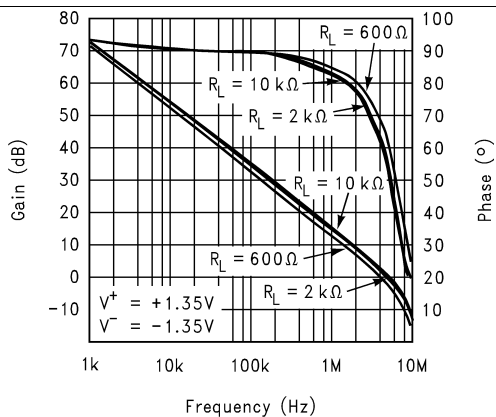

Figure 23. Open-Loop Frequency Response

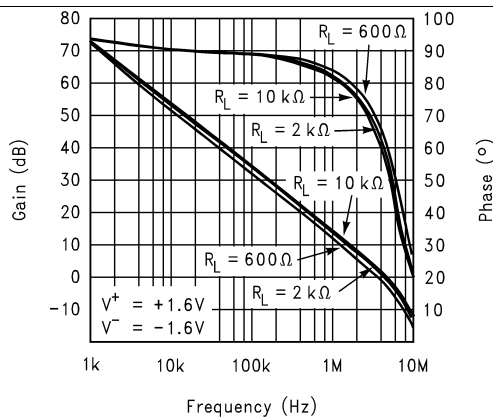

Figure 24. Open-Loop Frequency Response

Typical Characteristics (continued)

$V_S = 5\text{ V}$ , single supply,  $T_A = 25^\circ\text{C}$  (unless otherwise noted)

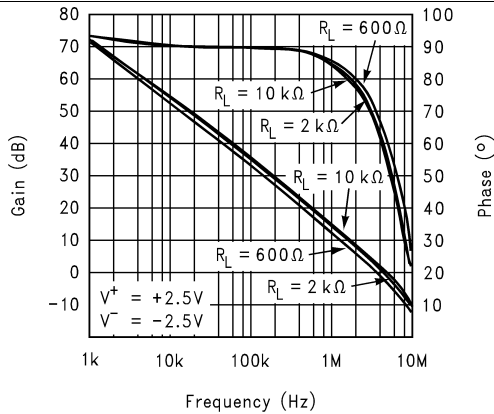

Figure 25. Open-Loop Frequency Response

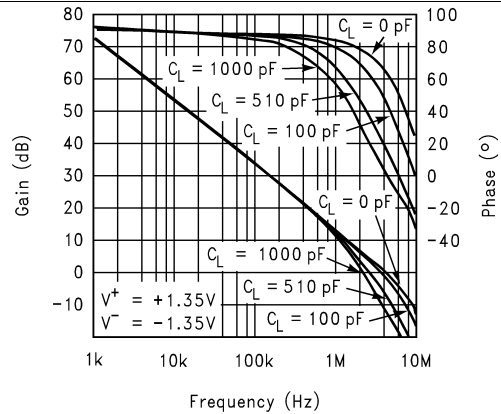

Figure 26. Open-Loop Frequency Response

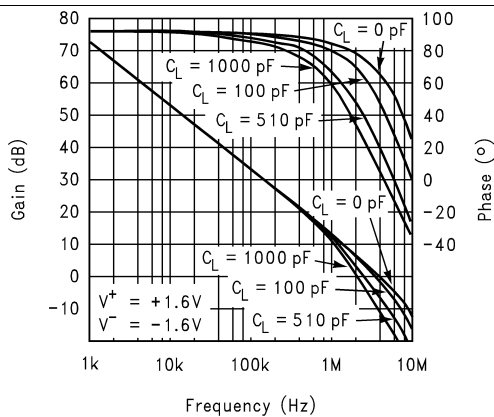

Figure 27. Open-Loop Frequency Response

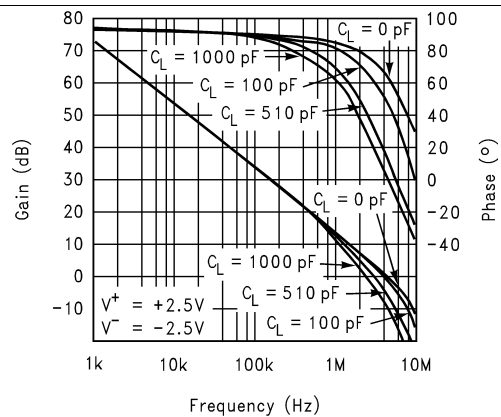

Figure 28. Open-Loop Frequency Response

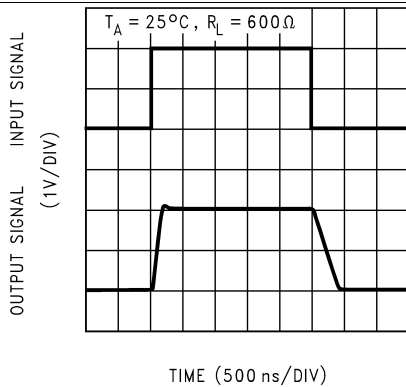

Figure 29. Noninverting Large Signal Pulse Response

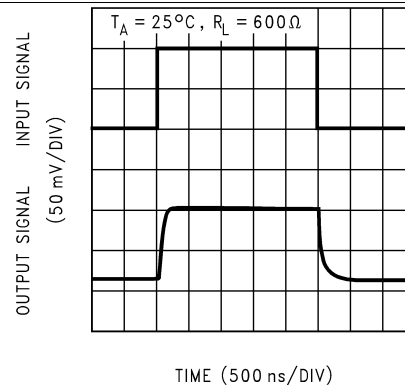
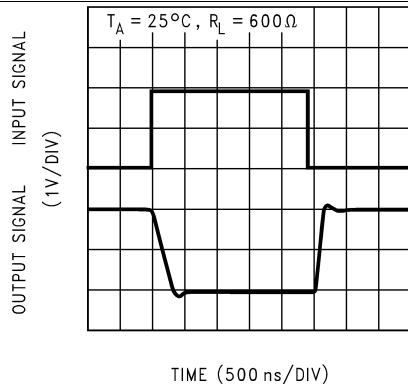

Figure 30. Noninverting Small Signal Pulse Response

**Typical Characteristics (continued)**

$V_S = 5\text{ V}$ , single supply,  $T_A = 25^\circ\text{C}$  (unless otherwise noted)



**Figure 31. Inverting Large-Signal Pulse Response**

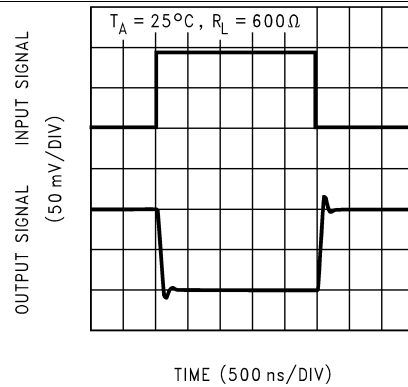

**Figure 32. Inverting Small-Signal Pulse Response**

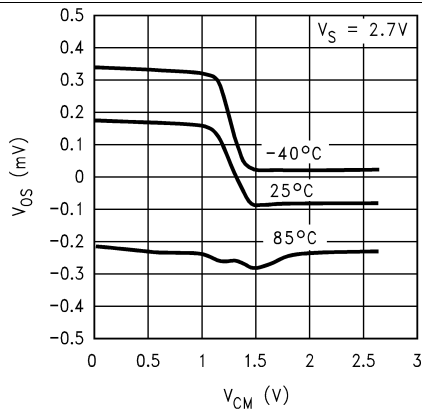

**Figure 33.  $V_{OS}$  vs  $V_{CM}$**

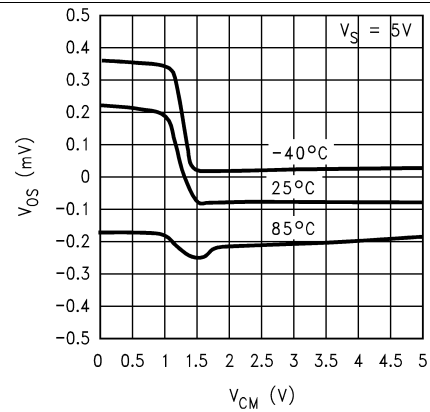

**Figure 34.  $V_{OS}$  vs  $V_{CM}$**

## 7 Detailed Description

### 7.1 Overview

The LMV710-N, LMV711-N, and LMV715-N operational amplifiers provide a CMOS input stage, high current drive rail-to-rail output, and a greater than RR input common mode voltage range. They also provide a slew rate of 5 V/ $\mu$ s at a bandwidth of 5 MHz.

### 7.2 Functional Block Diagram

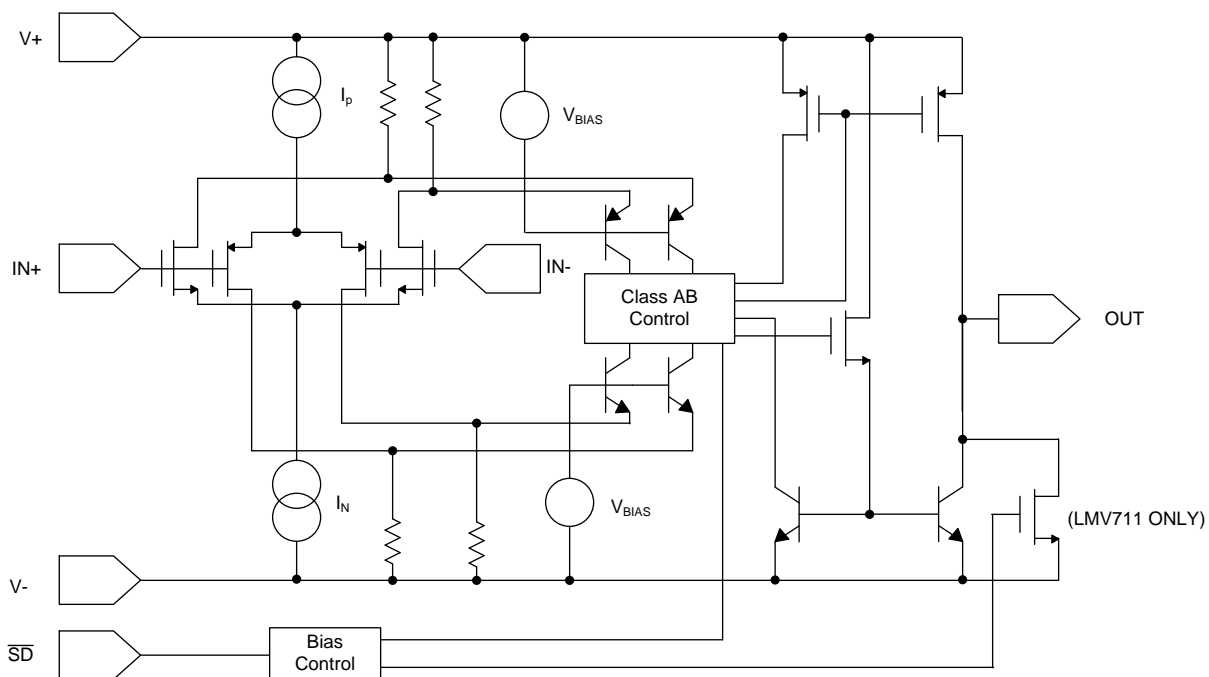

Copyright © 2016, Texas Instruments Incorporated

### 7.3 Feature Description

#### 7.3.1 Supply Bypassing

The application circuits in this datasheet do not show the power supply connections and the associated bypass capacitors for simplification. When the circuits are built, it is always required to have bypass capacitors. Ceramic disc capacitors (0.1  $\mu$ F) or solid tantalum (1  $\mu$ F) with short leads, and located close to the IC are usually necessary to prevent interstage coupling through the power supply internal impedance. Inadequate bypassing will manifest itself by a low frequency oscillation or by high frequency instabilities. Sometimes, a 10- $\mu$ F (or larger) capacitor is used to absorb low frequency variations and a smaller 0.1- $\mu$ F disc is paralleled across it to prevent any high frequency feedback through the power supply lines.

#### 7.3.2 Shutdown Mode

The LMV711 and LMV715 have a shutdown pin. To conserve battery life in portable applications, they can be disabled when the shutdown pin voltage is pulled low. For LMV711 during shutdown mode, the output stays at about 50 mV from the lower rail, and the current drawn from the power supply is 0.2  $\mu$ A (typical). This makes the LMV711 an ideal solution for power sensitive applications. For the LMV715 during shutdown mode, the output is tri-stated.

The shutdown pin must never be left unconnected. In applications where shutdown operation is not required and the LMV711 or LMV715 is used, the shutdown pin must be connected to  $V^+$ . Leaving the shutdown pin floating results in an undefined operation mode and the device may oscillate between shutdown and active modes.

## Feature Description (continued)

### 7.3.3 Rail-to-Rail Input

The rail-to-rail input is achieved by using paralleled PMOS and NMOS differential input stages (see [Functional Block Diagram](#)). When the common mode input voltage changes from ground to the positive rail, the input stage goes through three modes. First, the NMOS pair is cutoff and the PMOS pair is active. At around 1.4 V, both PMOS and NMOS pairs operate, and finally the PMOS pair is cutoff and NMOS pair is active. Because both input stages have their own offset voltage ( $V_{OS}$ ), the offset of the amplifier becomes a function of the common-mode input voltage (see [Figure 33](#) and [Figure 34](#) in [Typical Characteristics](#)).

As shown in the curve, the  $V_{OS}$  has a crossover point at 1.4 V above  $V^-$ . Proper design must be done in both DC- and AC-coupled applications to avoid problems. For large input signals that include the  $V_{OS}$  crossover point in their dynamic range, it causes distortion in the output signal. One way to avoid such distortion is to keep the signal away from the crossover point. For example, in a unity-gain buffer configuration and with  $V_S = 5$  V, a 3-V peak-to-peak signal center at 2.5 V contains input-crossover distortion. To avoid this, the input signal must be centered at 3.5 V instead. Another way to avoid large signal distortion is to use a gain of  $-1$  circuit which avoids any voltage excursions at the input terminals of the amplifier (see [Figure 35](#)). In this circuit, the common-mode DC voltage ( $V_{CM}$ ) can be set at a level away from the  $V_{OS}$  crossover point.

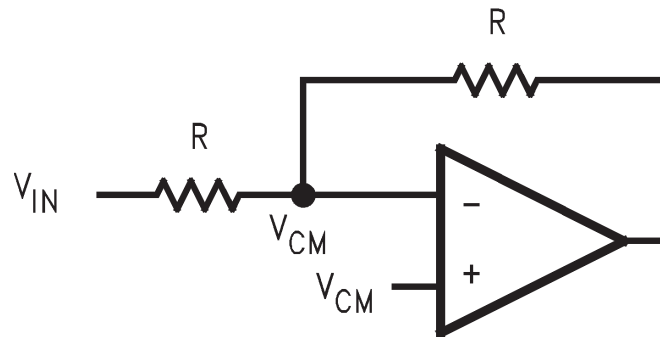

Figure 35. Inverting Configuration

When the input is a small signal and this small signal falls inside the  $V_{OS}$  transition range, the gain, CMRR and some other parameters is degraded. To resolve this problem, the small signal must be placed such that it avoids the  $V_{OS}$  crossover point.

To achieve maximum output swing, the output must be biased at mid-supply. This is normally done by biasing the input at mid-supply. But with supply voltage range from 2 V to 3.4 V, the input of the op amp must not be biased at mid-supply because of the transition of the  $V_{OS}$ . [Figure 36](#) shows an example of how to get away from the  $V_{OS}$  crossover point and maintain a maximum swing with a 2.7-V supply. [Figure 37](#) shows the waveforms of  $V_{IN}$  and  $V_{OUT}$ .

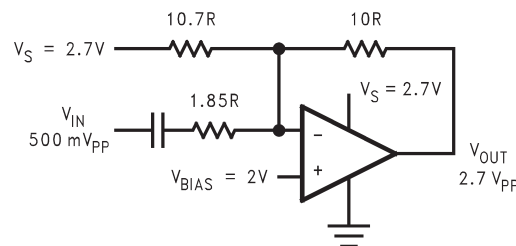
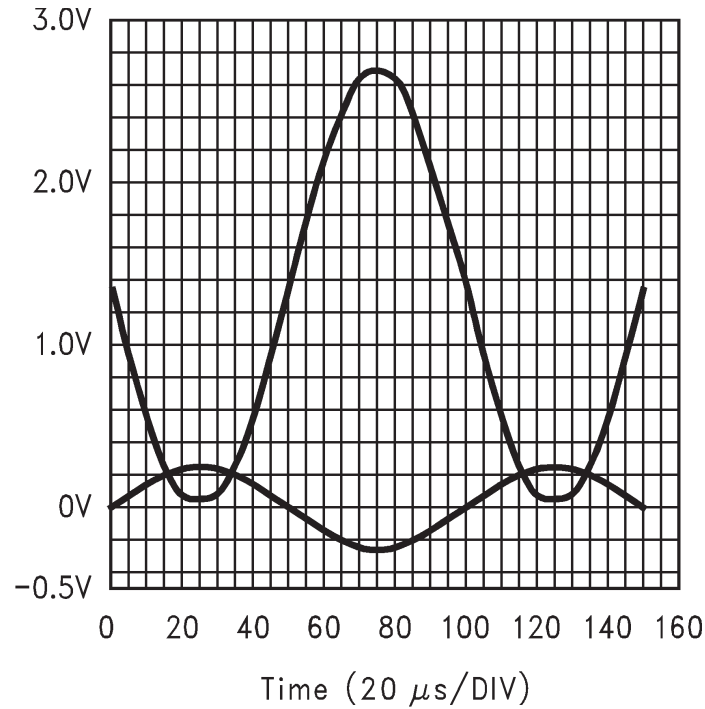

Figure 36. Vout biasing Example

**Feature Description (continued)**

**Figure 37. Vout biasing Output Results**

The inputs can be driven 300 mV beyond the supply rails without causing phase reversal at the output. However, the inputs must not be allowed to exceed the maximum ratings.

**7.4 Device Functional Modes**
**7.4.1 Compensation of Input Capacitance**

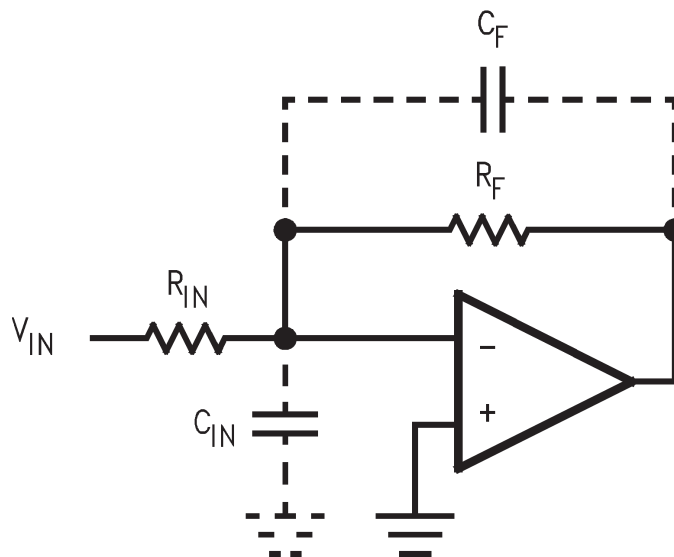
In the application (Figure 38) where a large feedback resistor is used, the feedback resistor can react with the input capacitance of the op amp and introduce an additional pole to the close loop frequency response.

**Figure 38. Cancelling the Effect of Input Capacitance**

## Device Functional Modes (continued)

This pole occurs at frequency  $f_p$  with Equation 1.

$$f_p = \frac{1}{2\pi(R_{IN} \parallel R_F)C_{IN}} \quad (1)$$

Any stray capacitance due to external circuit board layout, any source capacitance from transducer or photodiode connected to the summing node is added to the input capacitance. If  $f_p$  is less than or close to the unity-gain bandwidth (5 MHz) of the op amp, the phase margin of the loop is reduced and can cause the system to be unstable.

To avoid this problem, make sure that  $f_p$  occurs at least 2 octaves beyond the expected  $-3$  dB frequency corner of the close loop frequency response. If not, a feedback capacitor  $C_F$  can be placed in parallel with  $R_F$  such that Equation 2.

$$\frac{1}{2\pi R_F C_F} = \frac{1}{2\pi(R_{IN} \parallel R_F)(C_F + C_{IN})} \quad (2)$$

The paralleled  $R_F$  and  $C_F$  introduce a zero, which cancels the effect from the pole.

### 7.4.2 Capacitive Load Tolerance

The LMV71x-N can directly drive 200 pF in unity-gain without oscillation. The unity-gain follower is the most sensitive configuration to capacitive loading. Direct capacitive loading reduces the phase margin of amplifiers. The combination of the amplifier's output impedance and the capacitive load induces phase lag. This results in either an underdamped pulse response or oscillation. To drive a heavier capacitive load, circuit in Figure 39 can be used.

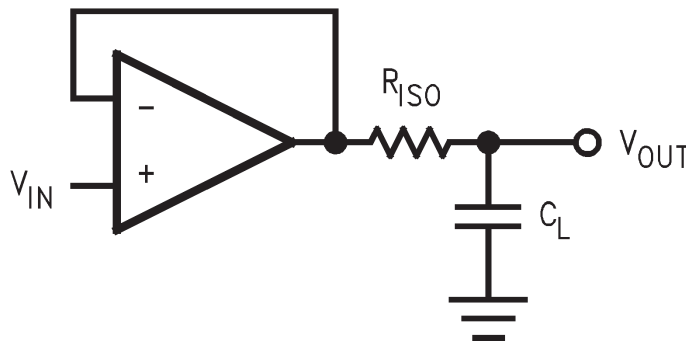
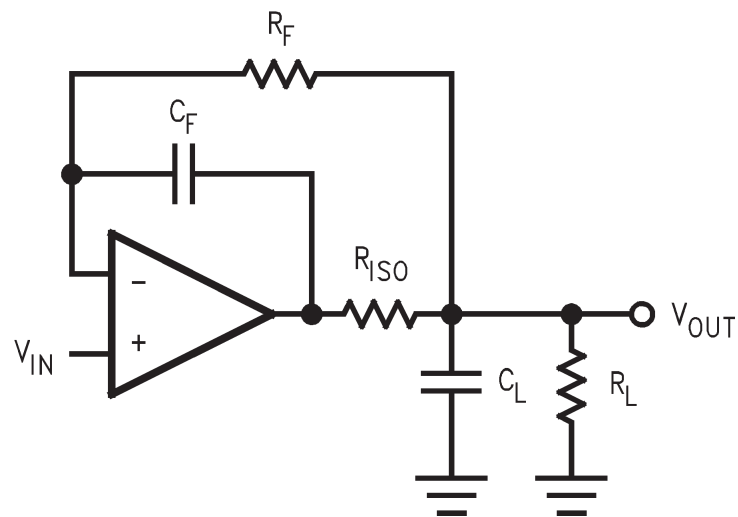

Figure 39. Indirectly Driving a Capacitive Load Using Resistive Isolation

In Figure 39, the isolation resistor  $R_{ISO}$  and the load capacitor  $C_L$  form a pole to increase stability by adding more phase margin to the overall system. The desired performance depends on the value of  $R_{ISO}$ . The bigger the  $R_{ISO}$  resistor value, the more stable  $V_{OUT}$  is. But the DC accuracy is not great when the  $R_{ISO}$  gets bigger. If there were a load resistor in Figure 39, the output would be voltage divided by  $R_{ISO}$  and the load resistor.

The circuit in Figure 40 is an improvement to the one in Figure 39 because it provides DC accuracy as well as AC stability. In this circuit,  $R_F$  provides the DC accuracy by using feed-forward techniques to connect  $V_{IN}$  to  $R_L$ .  $C_F$  and  $R_{ISO}$  serve to counteract the loss of phase margin by feeding the high-frequency component of the output signal back to the inverting input of the amplifier, thereby preserving phase margin in the overall feedback loop. Increased capacitive drive is possible by increasing the value of  $C_F$ . This in turn slows down the pulse response.

**Device Functional Modes (continued)**

**Figure 40. Indirectly Driving a Capacitive a Load With DC Accuracy**

## 8 Application and Implementation

### NOTE

Information in the following applications sections is not part of the TI component specification, and TI does not warrant its accuracy or completeness. TI's customers are responsible for determining suitability of components for their purposes. Customers should validate and test their design implementation to confirm system functionality.

### 8.1 Application Information

The LMV71x family of amplifiers features low voltage, low power, and rail-to-rail output operational amplifiers designed for low-voltage portable applications.

### 8.2 Typical Applications

#### 8.2.1 High-Side Current-Sensing

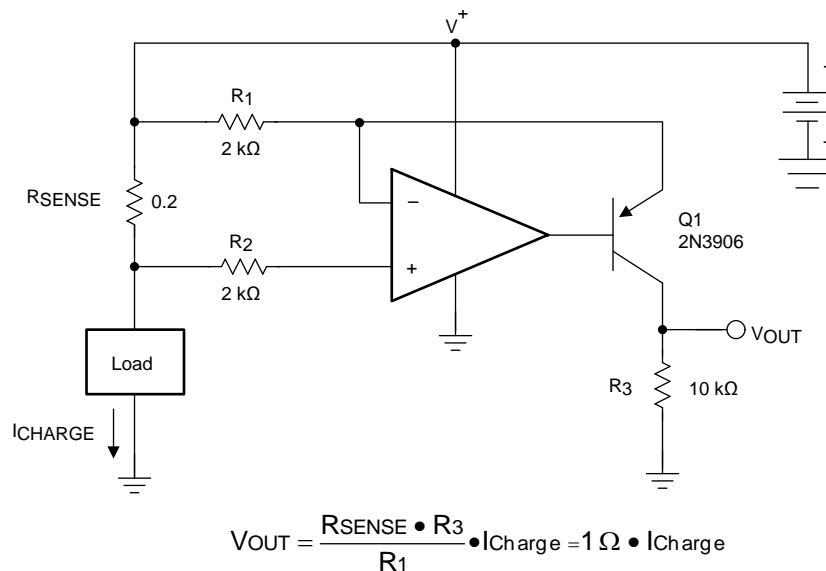

Copyright © 2016, Texas Instruments Incorporated

**Figure 41. High-Side, Current-Sensing Schematic**

##### 8.2.1.1 Design Requirements

The high-side, current-sensing circuit (Figure 41) is commonly used in a battery charger to monitor charging current to prevent over charging. A sense resistor  $R_{SENSE}$  is connected to the battery directly. This system requires an op amp with rail-to-rail input. The LMV71x are ideal for this application because its common-mode input range goes up to the rail.

##### 8.2.1.2 Detailed Design Procedure

As seen in (Figure 41), the  $I_{CHARGE}$  current flowing through sense resistor  $R_{SENSE}$  develops a voltage drop equal to  $V_{SENSE}$ . The voltage at the negative sense point is now less than the positive sense point by an amount proportional to the  $V_{SENSE}$  voltage.

The low-bias currents of the LMV71x cause little voltage drop through  $R_2$ , so the negative input of the LMV71x amplifier is at essentially the same potential as the negative sense input.

The LMV71x detects this voltage error between its inputs and servo the transistor base to conduct more current through Q1, increasing the voltage drop across  $R_1$  until the LMV71x inverting input matches the noninverting input. At this point, the voltage drop across  $R_1$  now matches  $V_{SENSE}$ .

$I_G$ , a current proportional to  $I_{CHARGE}$ , flows according to Equation 3.

## Typical Applications (continued)

$$I_G = V_{RSENSE} / R_1 = (R_{SENSE} \times I_{CHARGE}) / R_1 \quad (3)$$

$I_G$  also flows through the gain resistor  $R_3$  developing a voltage drop equal to [Equation 4](#).

$$V_3 = I_G \times R_3 = (V_{RSENSE} / R_1) \times R_3 = ((R_{SENSE} \times I_{CHARGE}) / R_2) \times R_3 \quad (4)$$

$$V_{OUT} = (R_{SENSE} \times I_{CHARGE}) \times G$$

where

- $G = R_3 / R_1$  (5)

The other channel of the LMV71x may be used to buffer the voltage across  $R_3$  to drive the following stages.

### 8.2.1.3 Application Curve

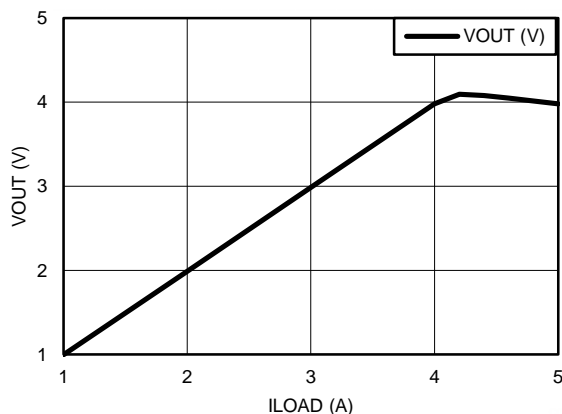

**Figure 42. High-Side Current-Sensing Results**

## 8.2.2 Peak Detector

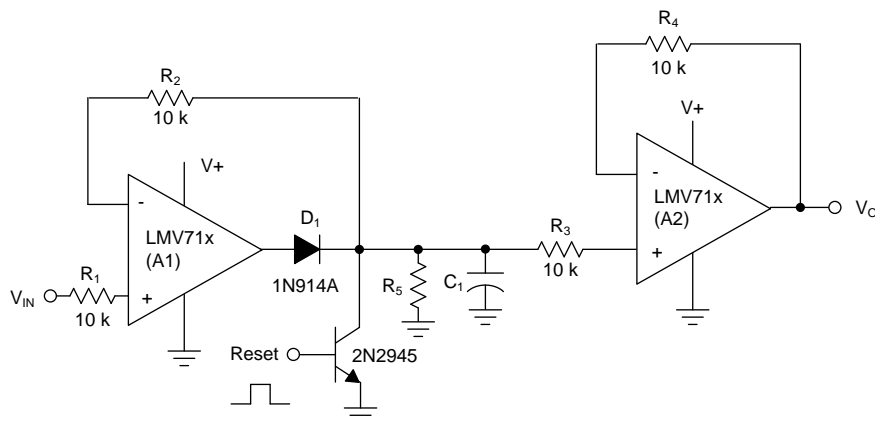

Copyright © 2016, Texas Instruments Incorporated

**Figure 43. Peak Detector**

### 8.2.2.1 Design Requirements

A peak detector outputs a DC voltage equal to the peak value of the applied AC signal. Peak detectors are used in many applications, such as test equipment, measurement instrumentation, ultrasonic alarm systems, and so forth. [Figure 43](#) shows the schematic diagram of a peak detector using LMV71x-N. This peak detector basically consists of a clipper, a parallel RC network, and a voltage follower.

## Typical Applications (continued)

### 8.2.2.2 Detailed Design Procedure

An AC voltage source applied to  $V_{IN}$  charges capacitor C1 to the peak of the input. Diode D1 conducts positive half cycles, charging C1 to the waveform peak. Including D1 inside the feedback loop of the amplifier removes the voltage drop of D1 and allows an accurate peak detection of  $V_{IN}$  on C1. When the input waveform falls below the DC peak stored on C1, D1 is reverse biased. The low input bias current of A1 and the reverse biasing of D1 limits current leakage from C1. As a result, C1 retains the peak value even as the waveform drops to zero. A2 further isolates the peak value on C1 while completing the peak detector circuit by operating as a voltage follower and reporting the peak voltage of C1 at its output.

R5 and C1 are properly selected so that the capacitor is charged rapidly to  $V_{IN}$ . During the holding period, the capacitor slowly discharge through C1, through leakage of the capacitor and the reverse-biased diode, or op amp bias currents. In any cases the discharging time constant is much larger than the charge time constant. And the capacitor can hold its voltage long enough to minimize the output ripple.

Resistors R2 and R3 limit the current into the inverting input of A1 and the noninverting input of A2 when power is disconnected from the circuit. The discharging current from C1 during power off may damage the input circuitry of the op amps.

The peak detector is reset by applying a positive pulse to the reset transistor. The charge on the capacitor is dumped into ground, and the detector is ready for another cycle.

The maximum input voltage to this detector must be less than  $(V^+ - V_D)$ , where  $V_D$  is the forward voltage drop of the diode. Otherwise, the input voltage must be scaled down before applying to the circuit.

### 8.2.3 GSM Power Amplifier Control Loop

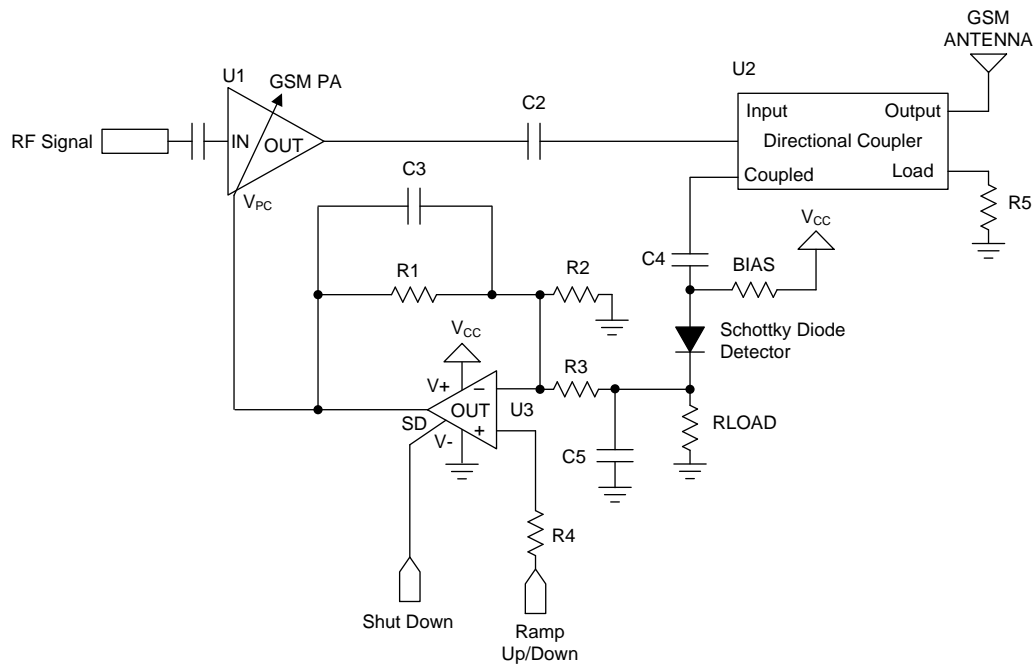

Copyright © 2016, Texas Instruments Incorporated

Figure 44. GSM P.A. Control Loop

#### 8.2.3.1 Design Requirements

The control loop in Figure 44 controls the output power level of a GSM mobile phones. The control loop is used to avoid intermodulation of Base Station receivers, to prevent intermodulation with other mobile phones, and to minimize power consumption depending on the distance between mobile and base station

## Typical Applications (continued)

### 8.2.3.2 Detailed Design Procedure

There are four critical sections in the GSM Power Amplifier Control Loop. The class-C  $R_F$  power amplifier provides amplification of the  $R_F$  signal. A directional coupler couples small amount of  $R_F$  energy from the output of the  $R_F$  P. A. to an envelope detector diode. The detector diode senses the signal level and rectifies it to a DC level to indicate the signal strength at the antenna. An op amp is used as an error amplifier to process the diode voltage and ramping voltage. This loop control the power amplifier gain through the op amp and forces the detector diode voltage and ramping voltage to be equal. Power control is accomplished by changing the ramping voltage.

The LMV71x-N are well suited as an error amplifier in this application. The LMV711 or LMV715 have an extra shutdown pin to switch the op amp to shutdown mode. In shutdown mode, the LMV711 or LMV715 consume very low current. The LMV711 provides a ground voltage to the power amplifier control pin  $V_{PC}$ . Therefore, the power amplifier can be turned off to save battery life. The LMV715 output is tri-stated when in shutdown.

## 9 Power Supply Recommendations

For proper operation, the power supplies must be properly decoupled. For decoupling the supply lines, TI recommends that 10-nF capacitors be placed as close as possible to the power supply pins of the operational amplifier. For single supply, place a capacitor between  $V^+$  and  $V^-$  supply leads. For dual supplies, place one capacitor between  $V^+$  and ground, and one capacitor between  $V^-$  and ground.

## 10 Layout

### 10.1 Layout Guidelines

To properly bypass the power supply, several locations on a printed-circuit board must be considered. A 6.8- $\mu$ F or greater tantalum capacitor must be placed at the point where the power supply for the amplifier is introduced onto the board. Another 0.1- $\mu$ F ceramic capacitor must be placed as close as possible to the power supply pin of the amplifier. If the amplifier is operated in a single power supply, only the  $V^+$  pin requires a bypass with a 0.1- $\mu$ F capacitor. If the amplifier is operated in a dual power supply, both  $V^+$  and  $V^-$  pins must be bypassed. It is good practice to use a ground plane on a printed-circuit board to provide all components with a low inductive ground connection.

### 10.2 Layout Example

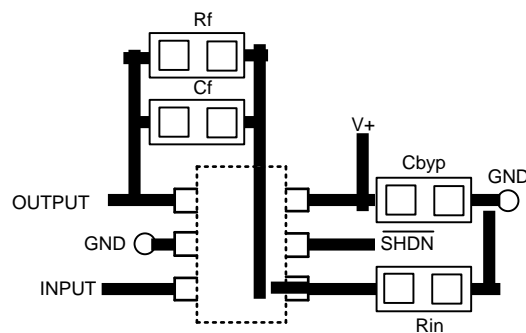

**Figure 45. LMV711 Layout Example**

## 11 Device and Documentation Support

### 11.1 Device Support

#### 11.1.1 Development Support

For development support see the following:

- [LMV710 PSPICE Model](#) (applicable for LMV711 and LMV715)
- SPICE-based analog simulation program, [TINA-TI](#)
- DIP adapter evaluation module, [DIP Adapter EVM](#)
- TI universal operational amplifier evaluation module, [Op Amp EVM](#)
- TI software, [FilterPro](#)

### 11.2 Documentation Support

#### 11.2.1 Related Documentation

For related documentation see the following:

- [Absolute Maximum Ratings for Soldering](#) (SNOA549)
- [AN-29 IC Op Amp Beats FETs on Input Current](#) (SNOA624)
- [AN-31 Op Amp Circuit Collection](#) (SNLA140)
- [AN-71 Micropower Circuits Using the LM4250 Programmable Op Amp](#) (SNOA652)
- [AN-127 LM143 Monolithic High Voltage Operational Amplifier Applications](#) (SNVA516)

### 11.3 Related Links

The table below lists quick access links. Categories include technical documents, support and community resources, tools and software, and quick access to sample or buy.

**Table 1. Related Links**

PARTS	PRODUCT FOLDER	SAMPLE & BUY	TECHNICAL DOCUMENTS	TOOLS & SOFTWARE	SUPPORT & COMMUNITY
LMV710-N	<a href="#">Click here</a>	<a href="#">Click here</a>	<a href="#">Click here</a>	<a href="#">Click here</a>	<a href="#">Click here</a>
LMV711-N	<a href="#">Click here</a>	<a href="#">Click here</a>	<a href="#">Click here</a>	<a href="#">Click here</a>	<a href="#">Click here</a>
LMV715-N	<a href="#">Click here</a>	<a href="#">Click here</a>	<a href="#">Click here</a>	<a href="#">Click here</a>	<a href="#">Click here</a>

### 11.4 Receiving Notification of Documentation Updates

To receive notification of documentation updates, navigate to the device product folder on ti.com. In the upper right corner, click on *Alert me* to register and receive a weekly digest of any product information that has changed. For change details, review the revision history included in any revised document.

### 11.5 Community Resources

The following links connect to TI community resources. Linked contents are provided "AS IS" by the respective contributors. They do not constitute TI specifications and do not necessarily reflect TI's views; see TI's [Terms of Use](#).

**TI E2E™ Online Community** *TI's Engineer-to-Engineer (E2E) Community*. Created to foster collaboration among engineers. At e2e.ti.com, you can ask questions, share knowledge, explore ideas and help solve problems with fellow engineers.

**Design Support** *TI's Design Support* Quickly find helpful E2E forums along with design support tools and contact information for technical support.

### 11.6 Trademarks

E2E is a trademark of Texas Instruments.

All other trademarks are the property of their respective owners.

## 11.7 Electrostatic Discharge Caution



These devices have limited built-in ESD protection. The leads should be shorted together or the device placed in conductive foam during storage or handling to prevent electrostatic damage to the MOS gates.

## 11.8 Glossary

[SLYZ022](#) — *TI Glossary*.

This glossary lists and explains terms, acronyms, and definitions.

## 12 Mechanical, Packaging, and Orderable Information

The following pages include mechanical, packaging, and orderable information. This information is the most current data available for the designated devices. This data is subject to change without notice and revision of this document. For browser-based versions of this data sheet, refer to the left-hand navigation.

**PACKAGING INFORMATION**

Orderable Device	Status (1)	Package Type	Package Drawing	Pins	Package Qty	Eco Plan (2)	Lead finish/ Ball material (6)	MSL Peak Temp (3)	Op Temp (°C)	Device Marking (4/5)	Samples
LMV710M5	NRND	SOT-23	DBV	5	1000	Non-RoHS & Green	Call TI	Level-1-260C-UNLIM	-40 to 85	A48A	
LMV710M5/NOPB	ACTIVE	SOT-23	DBV	5	1000	RoHS & Green	SN	Level-1-260C-UNLIM	-40 to 85	A48A	Samples
LMV710M5X/NOPB	ACTIVE	SOT-23	DBV	5	3000	RoHS & Green	SN	Level-1-260C-UNLIM	-40 to 85	A48A	Samples

(1) The marketing status values are defined as follows:

**ACTIVE:** Product device recommended for new designs.

**LIFEBUY:** TI has announced that the device will be discontinued, and a lifetime-buy period is in effect.

**NRND:** Not recommended for new designs. Device is in production to support existing customers, but TI does not recommend using this part in a new design.

**PREVIEW:** Device has been announced but is not in production. Samples may or may not be available.

**OBSELETE:** TI has discontinued the production of the device.

(2) **RoHS:** TI defines "RoHS" to mean semiconductor products that are compliant with the current EU RoHS requirements for all 10 RoHS substances, including the requirement that RoHS substance do not exceed 0.1% by weight in homogeneous materials. Where designed to be soldered at high temperatures, "RoHS" products are suitable for use in specified lead-free processes. TI may reference these types of products as "Pb-Free".

**RoHS Exempt:** TI defines "RoHS Exempt" to mean products that contain lead but are compliant with EU RoHS pursuant to a specific EU RoHS exemption.

**Green:** TI defines "Green" to mean the content of Chlorine (Cl) and Bromine (Br) based flame retardants meet JS709B low halogen requirements of <=1000ppm threshold. Antimony trioxide based flame retardants must also meet the <=1000ppm threshold requirement.

(3) MSL, Peak Temp. - The Moisture Sensitivity Level rating according to the JEDEC industry standard classifications, and peak solder temperature.

(4) There may be additional marking, which relates to the logo, the lot trace code information, or the environmental category on the device.

(5) Multiple Device Markings will be inside parentheses. Only one Device Marking contained in parentheses and separated by a "-" will appear on a device. If a line is indented then it is a continuation of the previous line and the two combined represent the entire Device Marking for that device.

(6) Lead finish/Ball material - Orderable Devices may have multiple material finish options. Finish options are separated by a vertical ruled line. Lead finish/Ball material values may wrap to two lines if the finish value exceeds the maximum column width.

**Important Information and Disclaimer:**The information provided on this page represents TI's knowledge and belief as of the date that it is provided. TI bases its knowledge and belief on information provided by third parties, and makes no representation or warranty as to the accuracy of such information. Efforts are underway to better integrate information from third parties. TI has taken and continues to take reasonable steps to provide representative and accurate information but may not have conducted destructive testing or chemical analysis on incoming materials and chemicals. TI and TI suppliers consider certain information to be proprietary, and thus CAS numbers and other limited information may not be available for release.

In no event shall TI's liability arising out of such information exceed the total purchase price of the TI part(s) at issue in this document sold by TI to Customer on an annual basis.

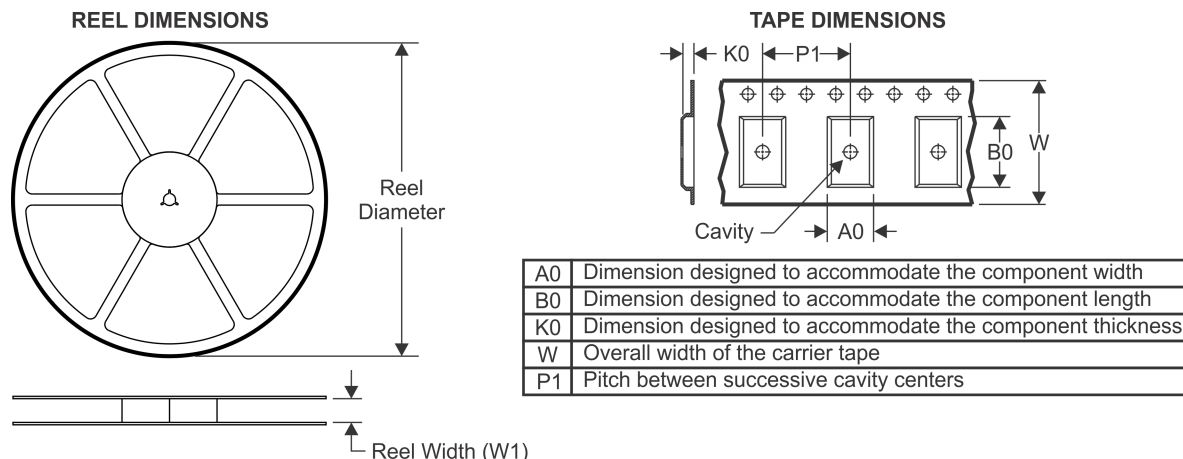
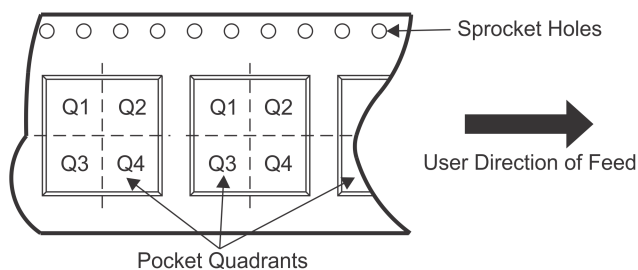
**TAPE AND REEL INFORMATION**

**QUADRANT ASSIGNMENTS FOR PIN 1 ORIENTATION IN TAPE**

\*All dimensions are nominal

Device	Package Type	Package Drawing	Pins	SPQ	Reel Diameter (mm)	Reel Width W1 (mm)	A0 (mm)	B0 (mm)	K0 (mm)	P1 (mm)	W (mm)	Pin1 Quadrant
LMV710M5	SOT-23	DBV	5	1000	178.0	8.4	3.2	3.2	1.4	4.0	8.0	Q3
LMV710M5/NOPB	SOT-23	DBV	5	1000	178.0	8.4	3.2	3.2	1.4	4.0	8.0	Q3
LMV710M5X/NOPB	SOT-23	DBV	5	3000	178.0	8.4	3.2	3.2	1.4	4.0	8.0	Q3

**TAPE AND REEL BOX DIMENSIONS**

\*All dimensions are nominal

Device	Package Type	Package Drawing	Pins	SPQ	Length (mm)	Width (mm)	Height (mm)
LMV710M5	SOT-23	DBV	5	1000	208.0	191.0	35.0
LMV710M5/NOPB	SOT-23	DBV	5	1000	208.0	191.0	35.0
LMV710M5X/NOPB	SOT-23	DBV	5	3000	208.0	191.0	35.0

DBV0005A



# PACKAGE OUTLINE

SOT-23 - 1.45 mm max height

SMALL OUTLINE TRANSISTOR

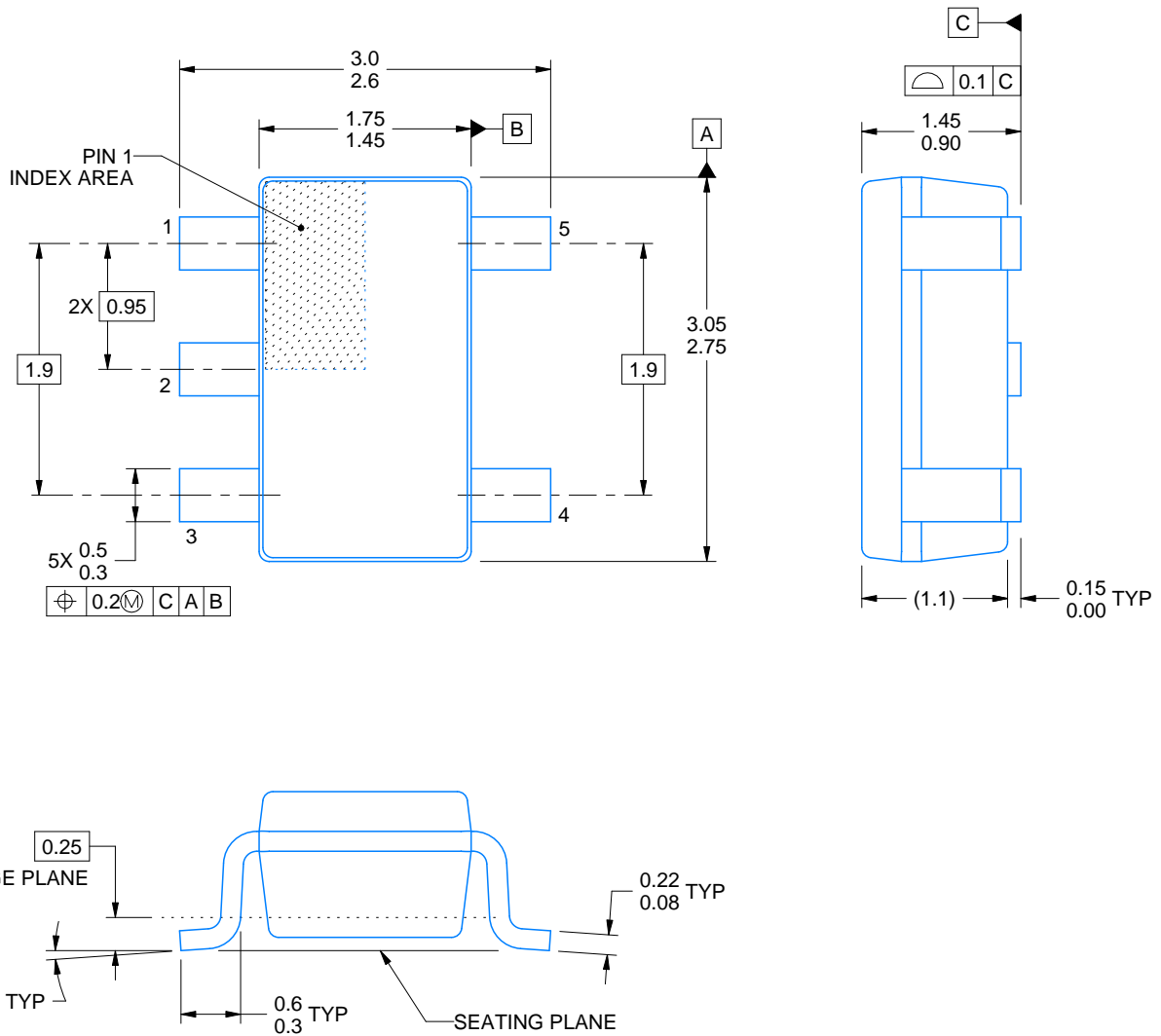

4214839/F 06/2021

## NOTES:

1. All linear dimensions are in millimeters. Any dimensions in parenthesis are for reference only. Dimensioning and tolerancing per ASME Y14.5M.
2. This drawing is subject to change without notice.
3. Reference JEDEC MO-178.
4. Body dimensions do not include mold flash, protrusions, or gate burrs. Mold flash, protrusions, or gate burrs shall not exceed 0.25 mm per side.

# EXAMPLE BOARD LAYOUT

DBV0005A

SOT-23 - 1.45 mm max height

SMALL OUTLINE TRANSISTOR

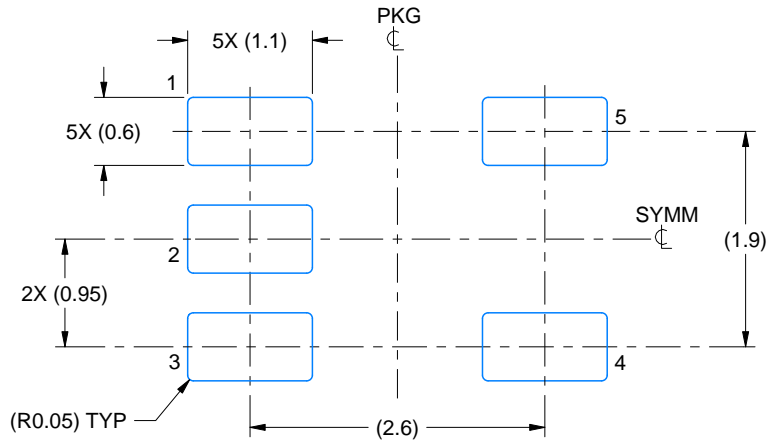

LAND PATTERN EXAMPLE  
EXPOSED METAL SHOWN  
SCALE:15X

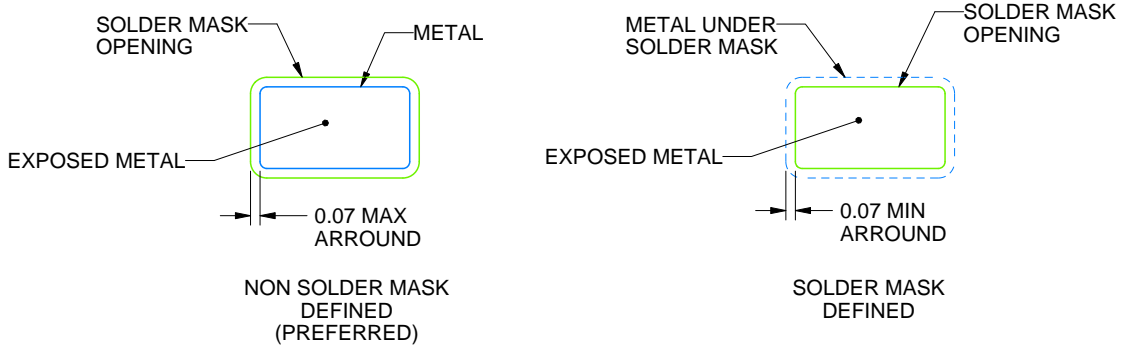

SOLDER MASK DETAILS

4214839/F 06/2021

NOTES: (continued)

- 5. Publication IPC-7351 may have alternate designs.
- 6. Solder mask tolerances between and around signal pads can vary based on board fabrication site.

# EXAMPLE STENCIL DESIGN

DBV0005A

SOT-23 - 1.45 mm max height

SMALL OUTLINE TRANSISTOR

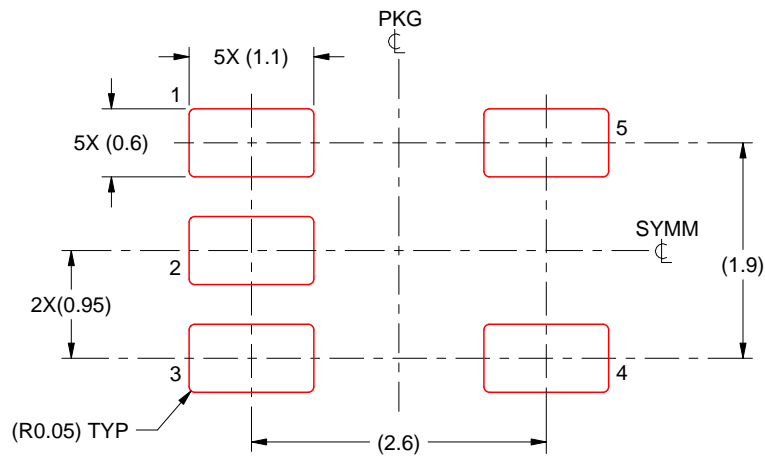

SOLDER PASTE EXAMPLE  
BASED ON 0.125 mm THICK STENCIL  
SCALE:15X

4214839/F 06/2021

NOTES: (continued)

7. Laser cutting apertures with trapezoidal walls and rounded corners may offer better paste release. IPC-7525 may have alternate design recommendations.
8. Board assembly site may have different recommendations for stencil design.

## IMPORTANT NOTICE AND DISCLAIMER

TI PROVIDES TECHNICAL AND RELIABILITY DATA (INCLUDING DATA SHEETS), DESIGN RESOURCES (INCLUDING REFERENCE DESIGNS), APPLICATION OR OTHER DESIGN ADVICE, WEB TOOLS, SAFETY INFORMATION, AND OTHER RESOURCES "AS IS" AND WITH ALL FAULTS, AND DISCLAIMS ALL WARRANTIES, EXPRESS AND IMPLIED, INCLUDING WITHOUT LIMITATION ANY IMPLIED WARRANTIES OF MERCHANTABILITY, FITNESS FOR A PARTICULAR PURPOSE OR NON-INFRINGEMENT OF THIRD PARTY INTELLECTUAL PROPERTY RIGHTS.

These resources are intended for skilled developers designing with TI products. You are solely responsible for (1) selecting the appropriate TI products for your application, (2) designing, validating and testing your application, and (3) ensuring your application meets applicable standards, and any other safety, security, regulatory or other requirements.

These resources are subject to change without notice. TI grants you permission to use these resources only for development of an application that uses the TI products described in the resource. Other reproduction and display of these resources is prohibited. No license is granted to any other TI intellectual property right or to any third party intellectual property right. TI disclaims responsibility for, and you will fully indemnify TI and its representatives against, any claims, damages, costs, losses, and liabilities arising out of your use of these resources.

TI's products are provided subject to [TI's Terms of Sale](#) or other applicable terms available either on [ti.com](http://ti.com) or provided in conjunction with such TI products. TI's provision of these resources does not expand or otherwise alter TI's applicable warranties or warranty disclaimers for TI products.

TI objects to and rejects any additional or different terms you may have proposed.

Mailing Address: Texas Instruments, Post Office Box 655303, Dallas, Texas 75265  
Copyright © 2021, Texas Instruments Incorporated