

UCCx895 BiCMOS 高级相移 PWM 控制器

1 特性

- 可编程输出接通延迟
- 自适应延迟设置
- 双向振荡器同步
- 电压模式、峰值电流模式或平均电流模式控制
- 通过单个引脚实现可编程的软启动、软停止和芯片禁用
- 0% 至 100% 占空比控制
- 7MHz 误差放大器
- 工作频率高达 1MHz
- 500kHz 下典型工作电流为 5mA
- UVLO 期间具有 150 μ A 的极低工作电流

2 应用

- 相移全桥转换器
- 离线、电信、数据通信和服务
- 分布式电源架构
- 高密度电源模块

3 说明

UCC3895 是一款相移 PWM 控制器，它通过相移切换一个半桥相对于另一半桥来实现对全桥功率级的控制。该器件支持恒定频率脉冲宽度调制和谐振零电压开关，可在高频下提供高效率。该器件既可用于电压模式控制器，也可用作电流模式控制器。

UCC3895 在保留了 UC3875/6/7/8 系列和 UC3879 的功能的同时，还改进了该控制器系列，使其具有增强的控制逻辑、自适应延迟设置和关断功能等附加功能。由于该器件采用 BCDMOS 工艺制造，因此与双极型同类器件相比，它的工作电流要小得多。UCC3895 的最大时钟频率为 1MHz。

器件信息(1)

器件型号	封装	封装尺寸 (标称值)
UCCx895	CDIP (20)	24.20mm x 6.92mm
	LCCC (20)	8.89mm x 8.89mm
	SOIC (20)	12.80mm x 7.50mm
	PDIP (20)	24.33mm x 6.35mm
	TSSOP (20)	6.50mm x 4.40mm
	PLCC (20)	8.96mm x 8.96mm

(1) 如需了解所有可用封装，请参阅数据表末尾的可订购产品附录。

简化应用示意图

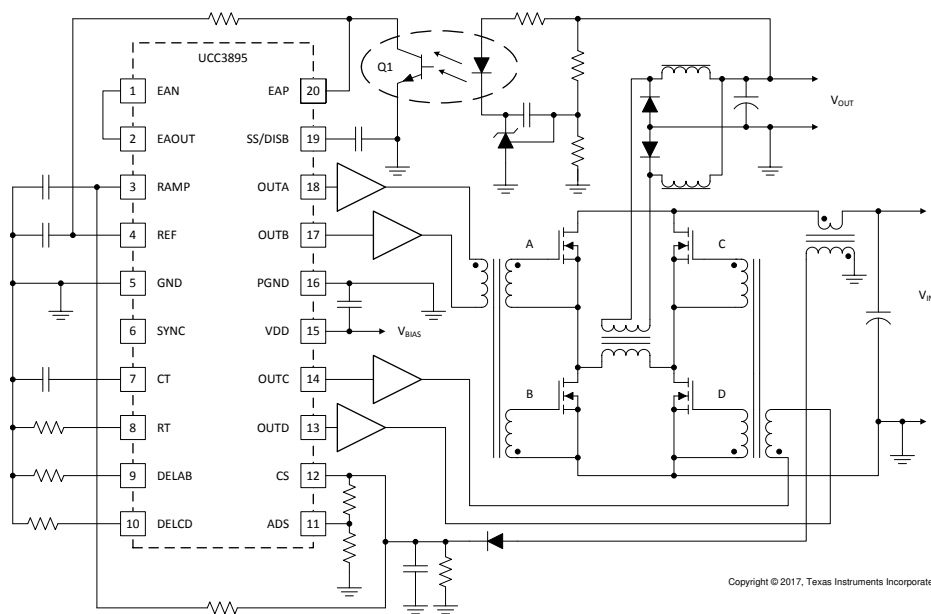

Copyright © 2017, Texas Instruments Incorporated



目录

1	特性	1	7.5	Programming.....	17
2	应用	1	8	Application and Implementation	20
3	说明	1	8.1	Application Information.....	20
4	修订历史记录	2	8.2	Typical Application	22
5	Pin Configuration and Functions	3	9	Power Supply Recommendations	42
6	Specifications.....	5	10	Layout.....	42
6.1	Absolute Maximum Ratings	5	10.1	Layout Guidelines	42
6.2	ESD Ratings.....	5	10.2	Layout Example	43
6.3	Recommended Operating Conditions.....	5	11	器件和文档支持	44
6.4	Thermal Information	6	11.1	文档支持	44
6.5	Electrical Characteristics.....	6	11.2	接收文档更新通知	44
6.6	Typical Characteristics.....	10	11.3	社区资源.....	44
7	Detailed Description	11	11.4	商标.....	44
7.1	Overview	11	11.5	静电放电警告.....	44
7.2	Functional Block Diagrams	11	11.6	Glossary	45
7.3	Feature Description.....	14	12	机械、封装和可订购信息.....	45
7.4	Device Functional Modes.....	17			

4 修订历史记录

注：之前版本的页码可能与当前版本有所不同。

Changes from Revision P (June 2013) to Revision Q		Page
•	已添加 添加了 <i>ESD</i> 额定值表、特性说明部分、器件功能模式、应用和实施部分、电源相关建议部分、布局部分、器件和文档支持部分以及机械、封装和可订购信息部分	1
•	Changed UCC1895 $V_{OL\ MAX}$, From 250 mV : To 300 mV in <i>Electrical Characteristics</i>	8
•	Changed UCC1895 RAMP sink current MIN, From 12 mA : To 10 mA in <i>Electrical Characteristics</i>	8
•	Changed the F_{SW} note in the <i>Detailed Design Procedure</i> section	23
•	Changed the voltage drop across the $R_{DS(on)}$ from 0.5-V to 4.5-V forward voltage drop in the output rectifiers.....	23
•	Added <i>Output Voltage Setpoint</i> section.....	34
•	Added <i>Setting the Switching Frequency</i> section	36
•	Added <i>Soft Start</i> section.....	36
•	Added <i>Setting the Switching Delays</i> section	36
•	Added <i>Setting the Slope Compensation</i> section	38

Changes from Revision O (April 2010) to Revision P		Page
•	Added <i>The CS input connects to</i> text to the beginning of the CS Detailed Pin Description	14
•	Added second paragraph to detailed REF Pin Description and included the UCC1895 at the end of the first paragraph to differentiate capacitance capabilities of the devices.....	16
•	Changed <i>UCC3895 Timing Diagram</i> in the Application Information section to reflect the maximum duty cycle conditions	19

Changes from Revision N (May 2009) to Revision O		Page
•	Changed REF pin description from “Do not use more than 1.0 μ F of total capacitance on this pin.” to “Do not use more than 4.7 μ F of total capacitance on this pin.”	16

5 Pin Configuration and Functions

PW AND DW PACKAGE DRAWINGS (TOP VIEW)

PW and DW PACKAGE
(TOP VIEW)

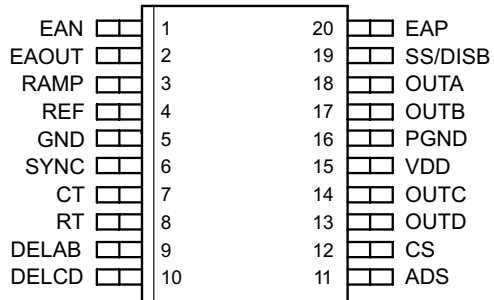

N AND J PACKAGE DRAWINGS (TOP VIEW)

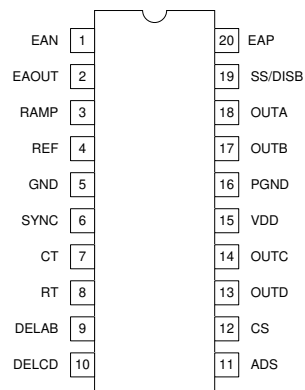

FN AND FK PACKAGE DRAWINGS (TOP VIEW)

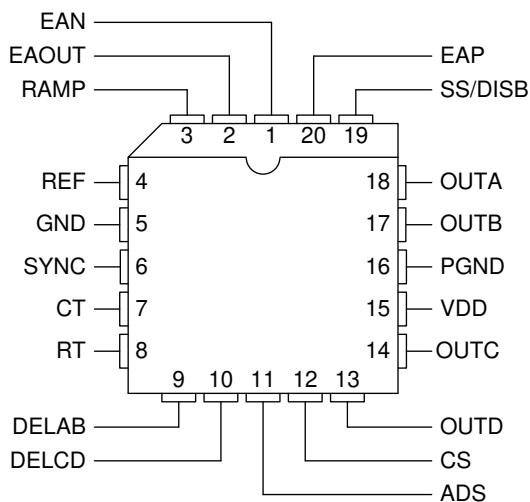

Pin Functions

PIN		I/O	DESCRIPTION
NAME	NO.		
ADS	11	I	The adaptive-delay-set pin sets the ratio between the maximum and minimum programmed output delay dead time.
CS	12	I	Current sense input for cycle-by-cycle current limiting and for over-current comparator.
CT	7	I	Oscillator timing capacitor for programming the switching frequency. The UCC3895 oscillator charges CT via a programmed current.
DELAB	9	I	The delay-programming between complementary-outputs pin, DELAB, programs the dead time between switching of output A and output B.
DELCD	10	I	The delay-programming between complementary-outputs pin, DELCD, programs the dead time between switching of output C and output D.
EAOUT	2	I/O	Error amplifier output.
EAP	20	I	Non-inverting input to the error amplifier. Keep below 3.6 V for proper operation.
EAN	1	I	Inverting input to the error amplifier. Keep below 3.6 V for proper operation.
GND	5	—	Chip ground for all circuits except the output stages.
OUTA	18	O	The four outputs are 100-mA complementary MOS drivers, and are optimized to drive FET driver circuits such as UCC27714 or gate drive transformers.
OUTB	17	O	
OUTC	14	O	
OUTD	13	O	
PGND	16	—	Output stage ground.
RAMP	3	I	Inverting input of the PWM comparator.
REF	4	O	5-V, $\pm 1.2\%$, 5-mA voltage reference. For best performance, bypass with a 0.1- μF low ESR, low ESL capacitor to ground. Do not use more than 4.7 μF of total capacitance on this pin.
RT	8	I	Oscillator timing resistor for programming the switching frequency.
SS/DISB	19	I	Soft-start and disable pin which combines the two independent functions.
SYNC	6	I/O	The oscillator synchronization pin is bidirectional.
VDD	15	I	The power supply input pin, VDD, must be bypassed with a minimum of a 1- μF low ESR, low ESL capacitor to ground. The addition of a 10- μF low ESR, low ESL between VDD and PGND is recommended.

6 Specifications

6.1 Absolute Maximum Ratings

over operating free-air temperature range (unless otherwise noted)⁽¹⁾

		MIN	MAX	UNIT
Supply voltage			17	V
Output current			100	mA
Reference current			15	mA
Supply current			30	mA
Analog inputs	EAP, EAN, EAOUT, RAMP, SYNC, ADS, CS, SS/DISB	-0.3	REF + 0.3	V
Drive outputs	OUTA, OUTB, OUTC, OUTD	-0.3	VCC + 0.3	V
Power dissipation at T _A = 25°C	DW-20 package		650	mW
	N-20 package		1	W
T _J	Junction temperature	-55	150	°C
T _{stg}	Storage temperature	-65	150	°C

- (1) Stresses beyond those listed under *Absolute Maximum Ratings* may cause permanent damage to the device. These are stress ratings only, which do not imply functional operation of the device at these or any other conditions beyond those indicated under *Recommended Operating Conditions*. Exposure to absolute-maximum-rated conditions for extended periods may affect device reliability.

6.2 ESD Ratings

		VALUE	UNIT
V _(ESD)	Electrostatic discharge	Human-body model (HBM), per ANSI/ESDA/JEDEC JS-001 ⁽¹⁾	±1000
		Charged-device model (CDM), per JEDEC specification JESD22-C101 ⁽²⁾	±1000

- (1) JEDEC document JEP155 states that 500-V HBM allows safe manufacturing with a standard ESD control process.

- (2) JEDEC document JEP157 states that 250-V CDM allows safe manufacturing with a standard ESD control process.

6.3 Recommended Operating Conditions

over operating free-air temperature range (unless otherwise noted)⁽¹⁾

		MIN	NOM	MAX	UNIT
V _{DD}	Supply voltage	10		16.5	V
V _{DD}	Supply voltage bypass capacitor ⁽²⁾		10 × C _{REF}		μF
C _{REF}	Reference bypass capacitor (UCC1895) ⁽³⁾	0.1		1	μF
C _{REF}	Reference bypass capacitor (UCC2895, UCC3895) ⁽³⁾	0.1		4.7	μF
C _T	Timing capacitor (for 500-kHz switching frequency)		220		pF
R _T	Timing resistor (for 500-kHz switching frequency)		82		kΩ
R _{DEL_AB} , R _{DEL_CD}	Delay resistor	2.5		40	kΩ
T _J	Operating junction temperature ⁽⁴⁾	-55		125	°C

- (1) TI recommends that there be a single point grounded between GND and PGND directly under the device. There must be a separate ground plane associated with the GND pin and all components associated with pins 1 through 12, plus 19 and 20, be located over this ground plane. Any connections associated with these pins to ground must be connected to this ground plane.
- (2) The V_{DD} capacitor must be a low ESR, ESL ceramic capacitor located directly across the V_{DD} and PGND pins. A larger bulk capacitor must be located as physically close as possible to the V_{DD} pins.
- (3) The V_{REF} capacitor must be a low ESR, ESL ceramic capacitor located directly across the REF and GND pins. If a larger capacitor is desired for the V_{REF} then it must be located near the V_{REF} cap and connected to the V_{REF} pin with a resistor of 51 Ω or greater. The bulk capacitor on V_{DD} must be a factor of 10 greater than the total V_{REF} capacitance.
- (4) TI does not recommend that the device operate under conditions beyond those specified in this table for extended periods of time.

6.4 Thermal Information

THERMAL METRIC ⁽¹⁾	UCC1895		UCC2895 UCC3895		UCC2895 UCC3895	UCC3895	UNIT
	J (CDIP)	FK (LCCC)	DW (SOIC)	PW (TSSOP)	FN (PLCC)	N (PDIP)	
	20 PINS	20 PINS	20 PINS	20 PINS	20 PINS	20 PINS	
R _{θJA} Junction-to-ambient thermal resistance	N/A	N/A	66.4	91.0	54.8	48.6	°C/W
R _{θJC(top)} Junction-to-case (top) thermal resistance	34.2	31.2	31.6	26.1	32.8	35.6	°C/W
R _{θJB} Junction-to-board thermal resistance	48.9	30.9	34.1	42.2	19.0	29.6	°C/W
ψ _{JT} Junction-to-top characterization parameter	N/A	N/A	8.6	1.3	9.0	16.0	°C/W
ψ _{JB} Junction-to-board characterization parameter	N/A	N/A	33.7	41.6	18.7	29.4	°C/W
R _{θJC(bot)} Junction-to-case (bottom) thermal resistance	8.9	3.3	N/A	N/A	N/A	N/A	°C/W

(1) For more information about traditional and new thermal metrics, see the *Semiconductor and IC Package Thermal Metrics* application report, [SPRA953](#).

6.5 Electrical Characteristics

V_{DD} = 12 V, R_T = 82 kΩ, C_T = 220 pF, R_{DELAB} = 10 kΩ, R_{DELCD} = 10 kΩ, C_{REF} = 0.1 μF, C_{VDD} = 0.1 μF and no load on the outputs, T_A = T_J. T_A = 0°C to 70°C for UCC3895x, T_A = -40°C to 85°C for UCC2895x and T_A = -55°C to 125°C for the UCC1895x (unless otherwise noted)

PARAMETER	TEST CONDITIONS	MIN	TYP	MAX	UNIT	
UVLO (UNDERVOLTAGE LOCKOUT)						
UVLO _(on) Start-up voltage threshold		10.2	11	11.8	V	
UVLO _(off) Minimum operating voltage after start-up		8.2	9	9.8	V	
UVLO _(hys) Hysteresis		1	2	3	V	
SUPPLY						
I _{START} Start-up current	VDD = 8 V		150	250	μA	
I _{DD} Operating current			5	6	mA	
V _{DD_CLAMP} V _{DD} clamp voltage	IDD = 10 mA	16.5	17.5	18.5	V	
VOLTAGE REFERENCE						
V _{REF} Output voltage	T _J = 25°C	4.94	5	5.06	V	
	10 V < VDD < V _{DD_CLAMP} , 0 mA < IREF < 5 mA, temperature	4.85	5	5.15		
I _{SC} Short circuit current	REF = 0 V, T _J = 25°C	10	20		mA	
ERROR AMPLIFIER						
	Common-mode input voltage range		-0.1	3.6	V	
V _{IO} Offset voltage			-7	7	mV	
I _{BIAS} Input bias current (EAP, EAN)			-1	1	μA	
EAOUT _{VOH} High-level output voltage	EAP – EAN = 500 mV, I _{EAOUT} = -0.5 mA	4	4.5	5	V	
EAOUT _{VOL} Low-level output voltage	EAP – EAN = -500 mV, I _{EAOUT} = 0.5 mA	0	0.2	0.4	V	
I _{SOURCE} Error amplifier output source current	EAP – EAN = 500 mV, EAOUT = 2.5 V	1	1.5		mA	
I _{SINK} Error amplifier output sink current	EAP – EAN = -500 mV, EAOUT = 2.5 V	2.5	4.5		mA	
A _{VOL} Open-loop dc gain		75	85		dB	
GBW Unity gain bandwidth ⁽¹⁾		5	7		mHz	
	Slew rate ⁽¹⁾		1.5	2.2	V/μs	
	No-load comparator turn-off threshold		0.45	0.5	0.55	V
	No-load comparator turn-on threshold		0.55	0.6	0.69	V

(1) Ensured by design. Not production tested.

Electrical Characteristics (continued)

$V_{DD} = 12\text{ V}$, $R_T = 82\text{ k}\Omega$, $C_T = 220\text{ pF}$, $R_{DELAB} = 10\text{ k}\Omega$, $R_{DELCD} = 10\text{ k}\Omega$, $C_{REF} = 0.1\text{ }\mu\text{F}$, $C_{VDD} = 0.1\text{ }\mu\text{F}$ and no load on the outputs, $T_A = T_J$. $T_A = 0^\circ\text{C}$ to 70°C for UCC3895x, $T_A = -40^\circ\text{C}$ to 85°C for UCC2895x and $T_A = -55^\circ\text{C}$ to 125°C for the UCC1895x (unless otherwise noted)

PARAMETER		TEST CONDITIONS	MIN	TYP	MAX	UNIT
No-load comparator hysteresis			0.035	0.1	0.165	V
OSCILLATOR						
f_{OSC}	Frequency	$T_J = 25^\circ\text{C}$	473	500	527	kHz
Frequency total variation		Over line, temperature		2.5%	5%	
V_{IH_SYNC}	SYNC input threshold, SYNC		2.05	2.1	2.4	V
V_{OH_SYNC}	High-level output voltage, SYNC	$I_{SYNC} = -400\text{ }\mu\text{A}$, $V_{CT} = 2.6\text{ V}$	4.1	4.5	5	V
V_{OL_SYNC}	Low-level output voltage, SYNC	$I_{SYNC} = 100\text{ }\mu\text{A}$, $V_{CT} = 0\text{ V}$	0	0.5	1	V
Sync output pulse width		$LOAD_{SYNC} = 3.9\text{ k}\Omega$ and 30 pF in parallel		85	135	ns
V_{RT}	Timing resistor voltage		2.9	3	3.1	V
$V_{CT(peak)}$	Timing capacitor peak voltage		2.25	2.35	2.55	V
$V_{CT(valley)}$	Timing capacitor valley voltage		0	0.2	0.4	V
CURRENT SENSE						
$I_{CS(bias)}$	Current sense bias current	$0\text{ V} < CS < 2.5\text{ V}$, $0\text{ V} ADS < 2.5\text{ V}$	-4.5		20	μA
Peak current threshold			1.9	2	2.1	V
Overcurrent threshold			2.4	2.5	2.6	V
Current sense to output delay		$0\text{ V} \leq CS \leq 2.3\text{ V}$, $DELAB = DELCD = REF$		75	110	ns
SOFT START/SHUTDOWN						
I_{SOURCE}	Soft-start source current	$SS/DISB = 3.0\text{ V}$, $CS = 1.9\text{ V}$	-40	-35	-30	μA
I_{SINK}	Soft-start sink current	$SS/DISB = 3.0\text{ V}$, $CS = 2.6\text{ V}$	325	350	375	μA
Soft-start/disable comparator threshold			0.44	0.5	0.56	V
ADAPTIVE DELAY SET (ADS)						
DELAB/DELCD output voltage		$ADS = CS = 0\text{ V}$	0.45	0.5	0.55	V
		$ADS = 0\text{ V}$, $CS = 2\text{ V}$	1.9	2	2.1	
t_{DELAY}	Output delay ⁽¹⁾⁽²⁾	$ADS = CS = 0\text{ V}$	450	560	620	ns
ADS bias current		$0\text{ V} < ADS < 2.5\text{ V}$, $0\text{ V} < CS < 2.5\text{ V}$	-20		20	μA

(2) Output delay is measured between OUTA and OUTB, or OUTC and OUTD. Output delay is defined as shown below where: $t_{f(OUTA)}$ = falling edge of OUTA signal, $t_{r(OUTB)}$ = rising edge of OUTB signal (see [Figure 1](#) and [Figure 2](#)).

Electrical Characteristics (continued)

$V_{DD} = 12\text{ V}$, $R_T = 82\text{ k}\Omega$, $C_T = 220\text{ pF}$, $R_{DELAB} = 10\text{ k}\Omega$, $R_{DELCD} = 10\text{ k}\Omega$, $C_{REF} = 0.1\text{ }\mu\text{F}$, $C_{VDD} = 0.1\text{ }\mu\text{F}$ and no load on the outputs, $T_A = T_J$. $T_A = 0^\circ\text{C}$ to 70°C for UCC3895x, $T_A = -40^\circ\text{C}$ to 85°C for UCC2895x and $T_A = -55^\circ\text{C}$ to 125°C for the UCC1895x (unless otherwise noted)

PARAMETER		TEST CONDITIONS	MIN	TYP	MAX	UNIT
OUTPUT						
V_{OH}	High-level output voltage (all outputs)	$I_{OUT} = -10\text{ mA}$, V_{DD} to output		250	400	mV
V_{OL}	Low-level output voltage (all outputs)	$I_{OUT} = 10\text{ mA}$	UCC1895	150	300	mV
			UCC2895, UCC3895	150	250	
t_R	Rise time ⁽¹⁾	$C_{LOAD} = 100\text{ pF}$		20	35	ns
t_F	Fall time ⁽¹⁾	$C_{LOAD} = 100\text{ pF}$		20	35	ns
PWM COMPARATOR						
	EAOUT to RAMP input offset voltage	RAMP = 0 V, DELAB = DELCD = REF	0.72	0.85	1.05	V
	Minimum phase shift ⁽³⁾ (OUTA to OUTC, OUTB to OUTD)	RAMP = 0 V, EAOUT = 650 mV	0.0%	0.85%	1.4%	
t_{DELAY}	Delay ⁽²⁾ (RAMP to OUTC, RAMP to OUTD)	0 V < RAMP < 2.5 V, EAOUT = 1.2 V, DELAB = DELCD = REF		70	120	ns
$I_{R(bias)}$	RAMP bias current	RAMP < 5 V, $C_T = 2.2\text{ V}$	-5		5	μA
$I_{R(sink)}$	RAMP sink current	RAMP = 5 V, $C_T = 2.6\text{ V}$	UCC1895	10	19	mA
			UCC2895, UCC3895	12	19	

(3) Minimum phase shift is defined as:

$$\Phi = 180 \times \frac{t_f(\text{OUTC}) - t_f(\text{OUTA})}{t_{\text{PERIOD}}} \quad \text{or} \quad \Phi = 180 \times \frac{t_f(\text{OUTC}) - t_f(\text{OUTB})}{t_{\text{PERIOD}}}$$

where

- (a) $t_f(\text{OUTA})$ = falling edge of OUTA signal
- (b) $t_f(\text{OUTB})$ = falling edge of OUTB signal
- (c) $t_f(\text{OUTC})$ = falling edge of OUTC signal
- (d) $t_f(\text{OUTD})$ = falling edge of OUTD signal
- (e) t_{PERIOD} = period of OUTA or OUTB signal

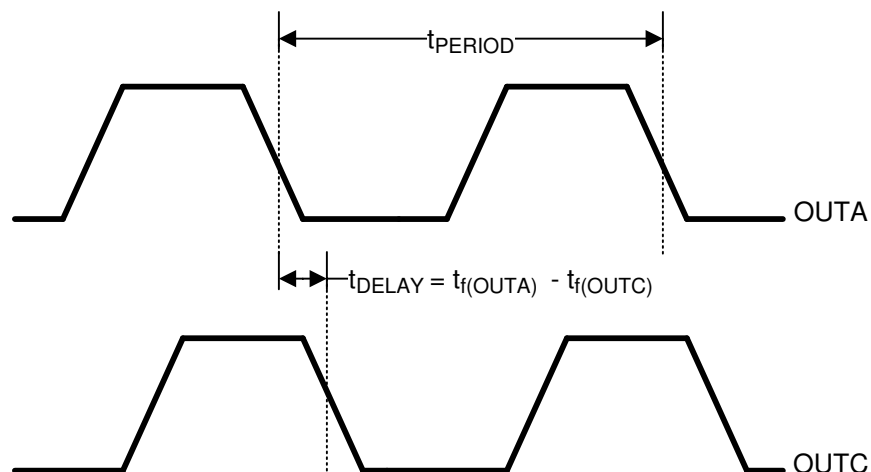

Figure 1. Same Applies to OUTB and OUTD

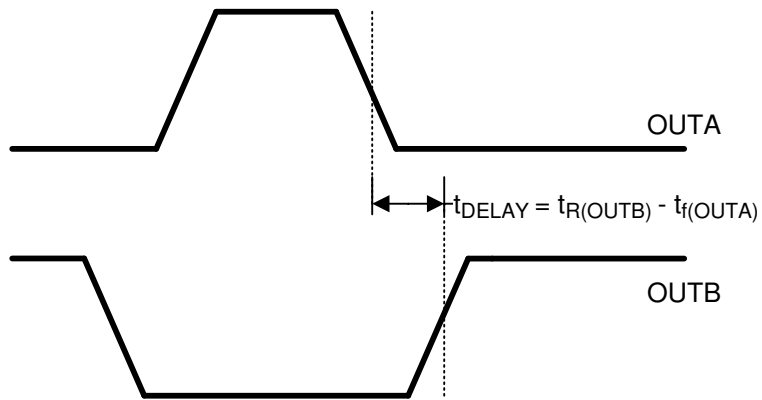

Figure 2. Same Applies to OUTC and OUTD

6.6 Typical Characteristics

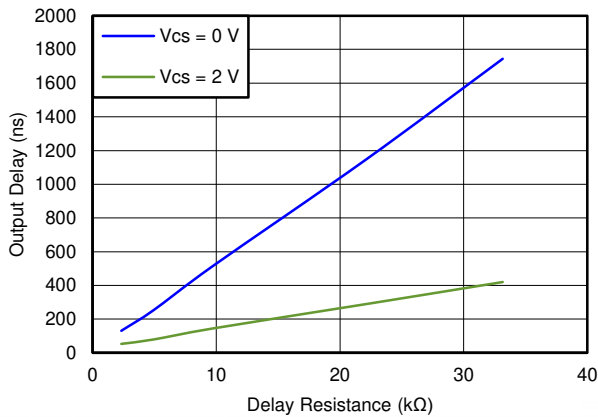

Figure 3. Output Delay (tDELAY) vs Delay Resistance (RDEL)

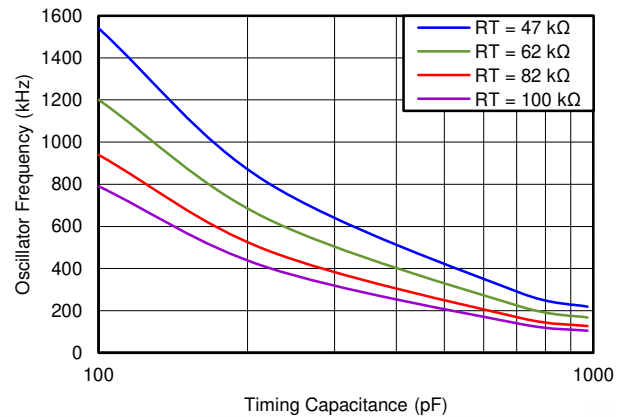

Figure 4. Oscillator Frequency (fSW) vs Timing Capacitance (CT)

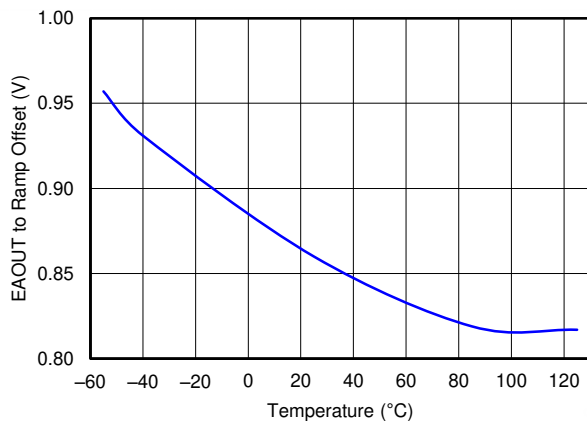

Figure 5. EAOUT to Ramp Offset (VOFFSET) vs Temperature (TA)

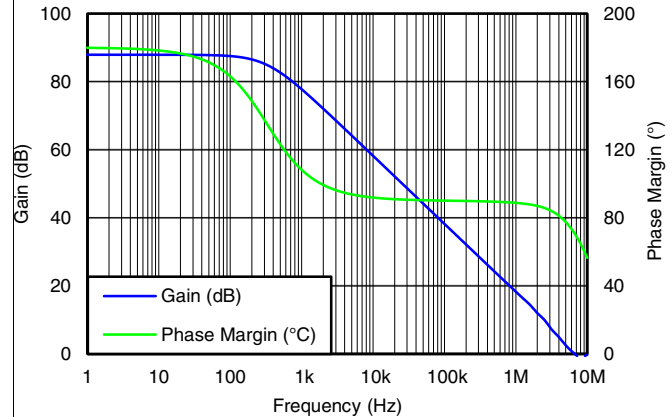

Figure 6. Amplifier Gain and Phase Margin vs Frequency (fOSC)

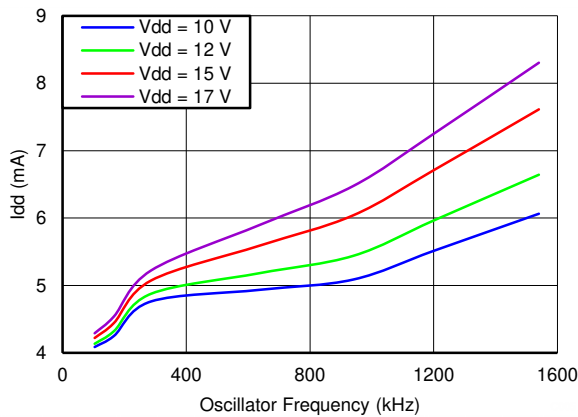

Figure 7. Input Current (IDD) vs Oscillator Frequency (fOSC)

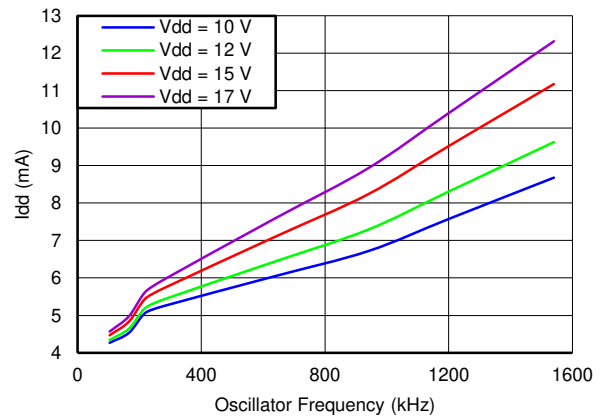

Figure 8. Input Current (IDD) vs Oscillator Frequency (fOSC)

7 Detailed Description

7.1 Overview

The UCC3895 device combines all the functions necessary to control a phase-shifted full bridge power stage in a 20-pin package. It includes all the outputs needed to drive the four switches in the full-bridge circuit. The dead times between the upper and lower switches in the full bridge may be set using the DELAB and DELCD inputs. Further, this dead time may be dynamically adjusted according to the load level using the ADS pin allowing the user to optimize the dead time for their particular power circuit and to achieve ZVS over the entire operating range. At light loads a no-load comparator forces cycle skipping to maintain output voltage regulation. The SS/DISB input may be used to set the length of the soft-start process and to turn the controller on and off. The controller may be used in Voltage mode or Current mode control and cycle-by-cycle current limiting is provided in both modes. The switching frequency may be set over a wide range making this device suited to both IGBT and MOSFET based designs.

7.2 Functional Block Diagrams

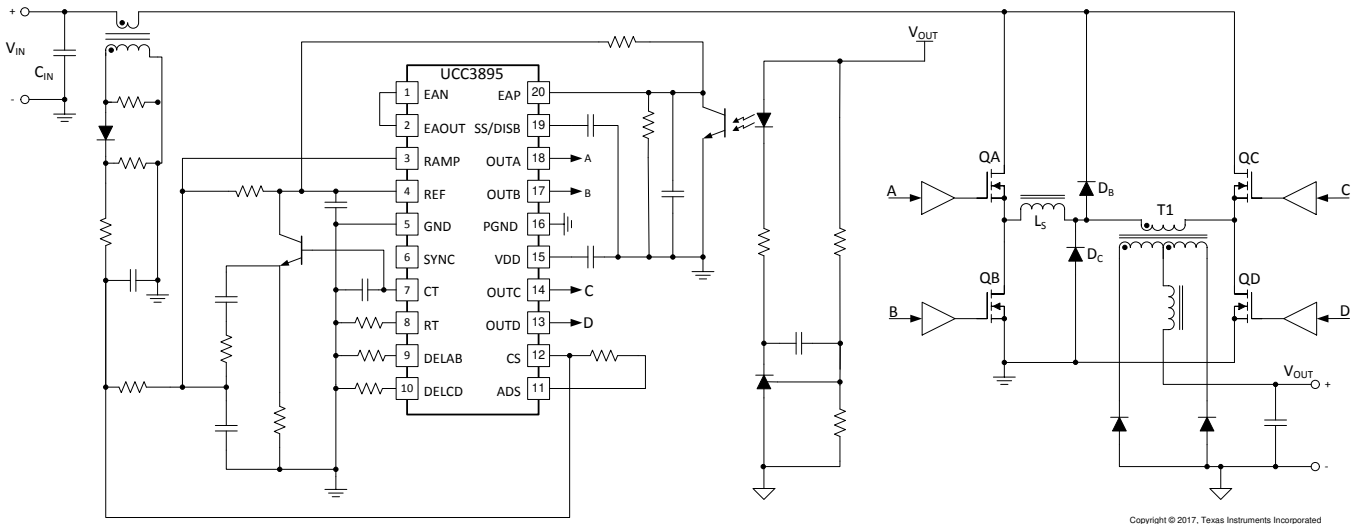
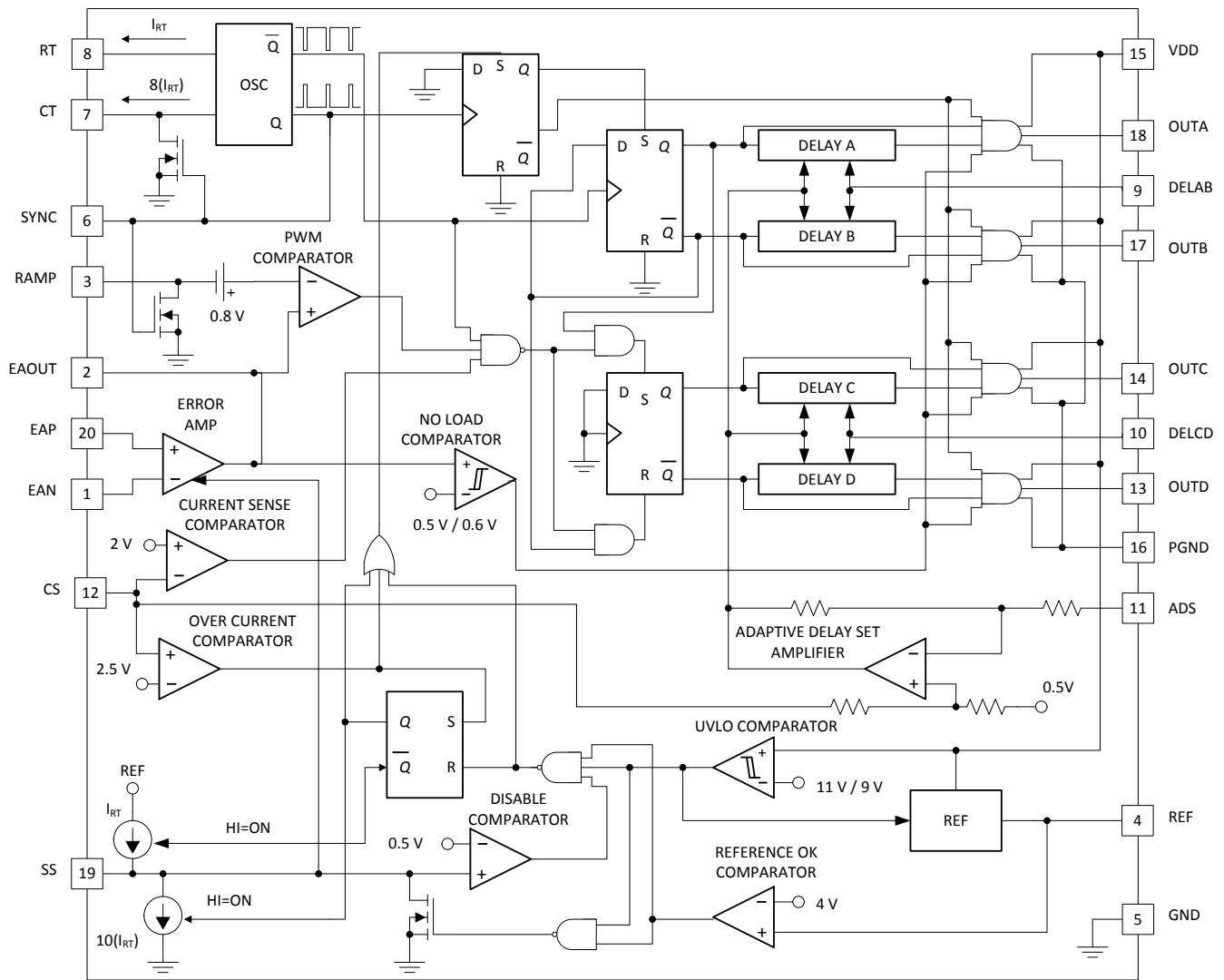

Figure 9. Simplified Application Diagram

Functional Block Diagrams (continued)



Copyright © 2017, Texas Instruments Incorporated

Figure 10. Block Diagram

Functional Block Diagrams (continued)

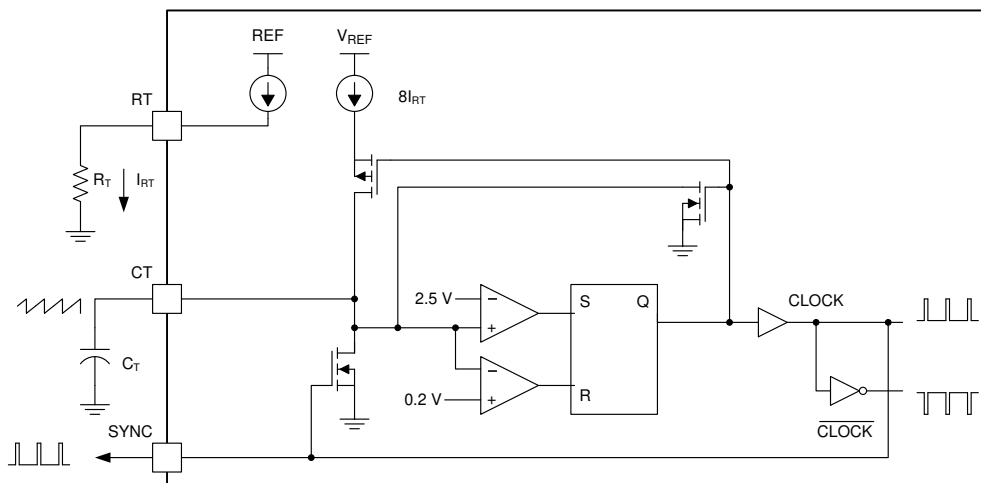

Figure 11. Oscillator Block Diagram

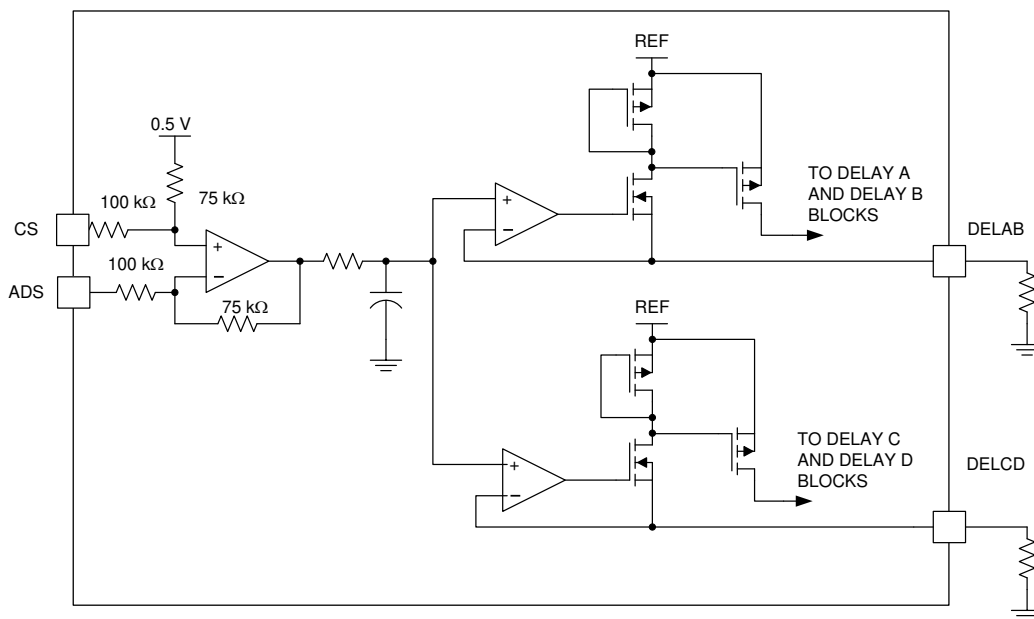
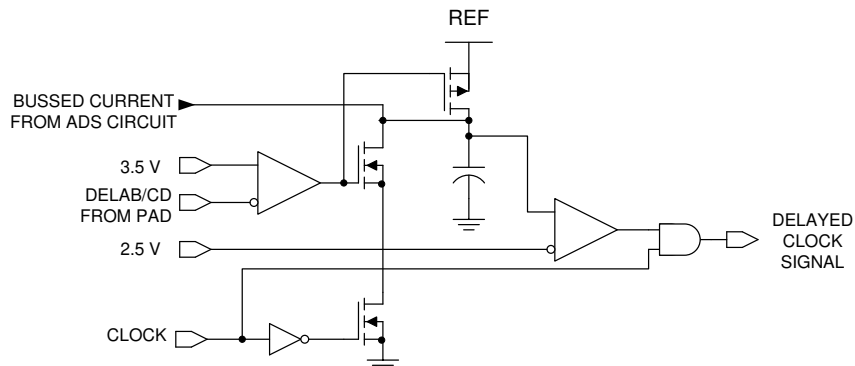

Figure 12. Adaptive Delay Set Block Diagram

Functional Block Diagrams (continued)

Figure 13. Delay Block Diagram (One Delay Block Per Outlet)
7.3 Feature Description
7.3.1 ADS (Adaptive Delay Set)

This function sets the ratio between the maximum and minimum programmed output-delay dead time. When the ADS pin is directly connected to the CS pin, no delay modulation occurs. The maximum delay modulation occurs when ADS is grounded. In this case, delay time is four-times longer when CS = 0 than when CS = 2 V (the peak-current threshold), ADS changes the output voltage on the delay pins DELAB and DELCD by [Equation 1](#).

$$V_{\text{DEL}} = [0.75 \times (V_{\text{CS}} - V_{\text{ADS}})] + 0.5 \text{ V}$$

where

- V_{CS} and V_{ADS} are in volts (1)

ADS must be limited to between 0 V and 2.5 V and must be less-than or equal-to CS. DELAB and DELCD are clamped to a minimum of 0.5 V.

7.3.2 CS (Current Sense)

The CS input connects to the inverting input of the current-sense comparator and the non-inverting input of the overcurrent comparator and the ADS amplifier. The current sense signal is used for cycle-by-cycle current limiting in peak current-mode control, and for overcurrent protection in all cases with a secondary threshold for output shutdown. An output disable initiated by an overcurrent fault also results in a restart cycle, called soft stop, with full soft start.

7.3.3 CT (Oscillator Timing Capacitor)

The UCC3895 oscillator charges CT via a programmed current. The waveform on C_T is a sawtooth, with a peak voltage of 2.35 V. The approximate oscillator period is calculated by [Equation 2](#).

$$t_{\text{OSC}} = \frac{5 \times R_T \times C_T}{48} + 120 \text{ ns}$$

where

- C_T is in Farads
- R_T is in Ohms
- t_{OSC} is in seconds
- C_T can range from 100 to 880 pF (2)

Feature Description (continued)

NOTE

A large C_T and a small R_T combination results in extended fall times on the C_T waveform. The increased fall time increases the SYNC pulse width, hence limiting the maximum phase shift between OUTA, OUTB and OUTC, OUTD outputs, which limits the maximum duty cycle of the converter (see [Figure 11](#)).

7.3.4 DELAB and DELCD (Delay Programming Between Complementary Outputs)

DELAB programs the dead time between switching of OUTA and OUTB. DELCD programs the dead time between OUTC and OUTD. This delay is introduced between complementary outputs in the same leg of the external bridge. The UCC3895 allows the user to select the delay, in which the resonant switching of the external power stages takes place. Separate delays are provided for the two half-bridges to accommodate differences in resonant-capacitor charging currents. The delay in each stage is set according to [Equation 3](#).

$$t_{\text{DELAY}} = \frac{(25 \times 10^{-12}) \times R_{\text{DEL}}}{V_{\text{DEL}}} + 25 \text{ ns}$$

where

- V_{DEL} is in volts
 - R_{DEL} is in Ohms
 - t_{DELAY} is in seconds
- (3)

DELAB and DELCD source about 1-mA maximum. Choose the delay resistors so that this maximum is not exceeded. Programmable output delay is defeated by tying DELAB and, or, DELCD to REF. For an optimum performance keep stray capacitance on these pins at less than 10 pF.

7.3.5 EAOUT, EAP, and EAN (Error Amplifier)

EAOUT connects internally to the non-inverting input of the PWM comparator and the no-load comparator. EAOUT is internally clamped to the soft-start voltage. The no-load comparator shuts down the output stages when EAOUT falls below 500 mV, and allows the outputs to turn on again when EAOUT rises above 600 mV.

EAP is the non-inverting and the EAN is the inverting input to the error amplifier.

7.3.6 OUTA, OUTB, OUTC, and OUTD (Output MOSFET Drivers)

The four outputs are 100-mA complementary MOS drivers, and are optimized to drive MOSFET driver circuits. OUTA and OUTB are fully complementary, (assuming no programming delay) and operate near 50% duty cycle and one-half the oscillator frequency. OUTA and OUTB are intended to drive one half-bridge circuit in an external power stage. OUTC and OUTD drive the other half-bridge and have the same characteristics as OUTA and OUTB. OUTC is phase shifted with respect to OUTA, and OUTD is phase shifted with respect to OUTB.

NOTE

Changing the phase relationship of OUTC and OUTD with respect to OUTA and OUTB requires other than the nominal 50% duty ratio on OUTC and OUTD during those transients.

7.3.7 PGND (Power Ground)

To keep output switching noise from critical analog circuits, the UCC3895 has two different ground connections. PGND is the ground connection for the high-current output stages. Both GND and PGND must be electrically tied together. Also, because PGND carries high current, board traces must be low impedance.

7.3.8 RAMP (Inverting Input of the PWM Comparator)

This pin receives either the C_T waveform in voltage and average current-mode controls, or the current signal (plus slope compensation) in peak current-mode control.

Feature Description (continued)

7.3.9 REF (Voltage Reference)

The 5-V \pm 1.2% reference supplies power to internal circuitry, and also supplies up to 5 mA to external loads. The reference is shutdown during undervoltage lockout but is operational during all other disable modes. For best performance, bypass with a 0.1- μ F low-ESR low-ESL capacitor to GND. To ensure the stability of the internal reference, do not use more than 1 μ F of total capacitance on this pin for the UCC1895.

For the UCC2895 and the UCC3895, this capacitance increases as per the limits defined in the [Recommended Operating Conditions](#) of this specification.

7.3.10 RT (Oscillator Timing Resistor)

The oscillator in the UCC3895 operates by charging an external timing capacitor, C_T , with a fixed current programmed by R_T . R_T current is calculated with [Equation 4](#).

$$I_{RT} \text{ (A)} = \frac{3 \text{ V}}{R_T \text{ (\Omega)}} \quad (4)$$

R_T ranges from 40 k Ω to 120 k Ω . Soft-start charging and discharging currents are also programmed by I_{RT} (Refer to [Figure 11](#)).

7.3.11 GND (Analog Ground)

This pin is the chip ground for all internal circuits except the output stages.

7.3.12 SS/DISB (Soft Start/Disable)

This pin combines two independent functions.

Disable Mode: A rapid shutdown of the chip is accomplished by externally forcing SS/DISB below 0.5 V, externally forcing REF below 4 V, or if VDD drops below the undervoltage lockout threshold. In the case of REF being pulled below 4 V or an undervoltage condition, SS/DISB is actively pulled to ground via an internal MOSFET switch.

If an overcurrent fault is sensed ($CS = 2.5 \text{ V}$), a soft stop is initiated. In this mode, SS/DISB sinks a constant current of ($10 \times I_{RT}$). The soft stop continues until SS/DISB falls below 0.5 V. When any of these faults are detected, all outputs are forced to ground immediately.

NOTE

If SS/DISB is forced below 0.5 V, the pin starts to source current equal to I_{RT} . The only time the part switches into low I_{DD} current mode, though, is when the part is in undervoltage lockout.

Soft Start Mode: After a fault or disable condition has passed, VDD is above the start threshold, and, or, SS/DISB falls below 0.5 V during a soft stop, SS/DISB switches to a soft-start mode. The pin then sources current, equal to I_{RT} . A user-selected resistor/capacitor combination on SS/DISB determines the soft-start time constant.

NOTE

SS/DISB actively clamps the EAOUT pin voltage to approximately the SS/DISB pin voltage during soft-start, soft-stop, and disable conditions.

Feature Description (continued)

7.3.13 SYNC (Oscillator Synchronization)

This pin is bidirectional (refer to [Figure 11](#)). When used as an output, SYNC is used as a clock, which is the same as the internal clock of the device. When used as an input, SYNC overrides the internal oscillator of the chip and acts as the clock signal. This bidirectional feature allows synchronization of multiple power supplies. Also, the SYNC signal internally discharge the C_T capacitor and any filter capacitors that are present on the RAMP pin. The internal SYNC circuitry is level sensitive, with an input-low threshold of 1.9 V, and an input-high threshold of 2.1 V. A resistor as small as 3.9 k Ω may be tied between SYNC and GND to reduce the sync pulse width.

7.3.14 VDD (Chip Supply)

This is the input pin to the chip. VDD must be bypassed with a minimum of 1- μ F low ESR, low ESL capacitor to ground. The addition of a 10- μ F low ESR, low ESL between VDD and PGND is recommended.

7.4 Device Functional Modes

The UCC3895 has a number of operational modes. These modes are described in detail in [Feature Description](#) section.

- Current mode - The UCC3895 device may be operated in current mode control. The CS pin is connected to the current sense signal plus slope compensation. The RAMP pin is connected to the CS pin.
- Voltage mode - The UCC3895 may be operated in voltage mode control. The RAMP pin is connected to the signal at CT.
- Light load mode - Under light load conditions the signal at the EAOUT pin can fall below the threshold of the No-Load-Comparator. When this happens the UCC3895 maintains output regulation by skipping cycles.
- Synchronized mode - Multiple UC3895 devices may be synchronised to each other or to an external clock signal.
- Disable mode - The device will stop if the EN/DISB pin is pulled below 0.5 V.
- Soft-start mode - This mode protects the power stage from excessive stresses during the start-up process.

7.5 Programming

7.5.1 Programming DELAB, DELCD and the Adaptive Delay Set

The UCC3895 allows the user to set the delay between switch commands within each leg of the full-bridge power circuit according to [Equation 5](#).

$$t_{\text{DELAY}} = \frac{(25 \times 10^{-12}) \times R_{\text{DEL}}}{V_{\text{DEL}}} + 25 \text{ ns} \quad (5)$$

From [Equation 5](#) V_{DEL} is determined in conjunction with the desire to use (or not) the ADS feature from [Equation 6](#).

$$V_{\text{DEL}} = [0.75 \times (V_{\text{CS}} - V_{\text{ADS}})] + 0.5 \text{ V} \quad (6)$$

[Figure 14](#) illustrates the resistors needed to program the delay periods and the ADS function.

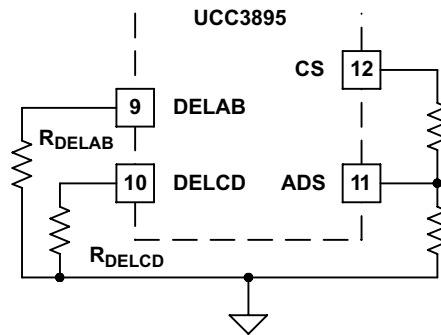
Programming (continued)

Figure 14. Programming Adaptive Delay Set

The ADS allows the user to vary the delay times between switch commands within each of the two legs of the converter. The delay-time modulation is implemented by connecting ADS (pin 11) to CS, GND, or a resistive divider from CS through ADS to GND to set V_{ADS} as shown in Figure 14. From Equation 6 for V_{DEL} , if ADS is tied to GND then V_{DEL} rises in direct proportion to V_{CS} , causing a decrease in t_{DELAY} as the load increases. In this condition, the maximum value of V_{DEL} is 2 V.

If ADS is connected to a resistive divider between CS and GND, the term $(V_{CS} - V_{ADS})$ becomes smaller, reducing the level of V_{DEL} . This reduction decreases the amount of delay modulation. In the limit of ADS tied to CS, $V_{DEL} = 0.5$ V and no delay modulation occurs. Figure 15 graphically shows the delay time versus load for varying adaptive delay set feature voltages (V_{ADS}).

In the case of maximum delay modulation (ADS = GND), when the circuit goes from light load to heavy load, the variation of V_{DEL} is from 0.5 to 2 V. This change causes the delay times to vary by a 4:1 ratio as the load is changed.

The ability to program an adaptive delay is a desirable feature because the optimum delay time is a function of the current flowing in the primary winding of the transformer, and changes by a factor of 10:1 or more as circuit loading changes. Reference 7 (see the [相关文档](#) section) describes the many interrelated factors for choosing the optimum delay times for the most efficient power conversion, and illustrates an external circuit to enable ADS using the UC3879. Implementing this adaptive feature is simplified in the UCC3895 controller, giving the user the ability to tailor the delay times to suit a particular application with a minimum of external parts.

Programming (continued)

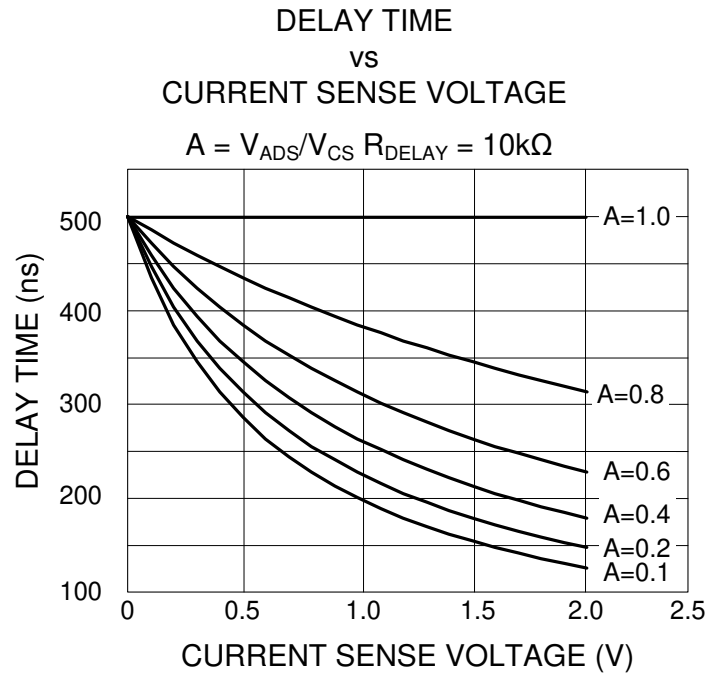
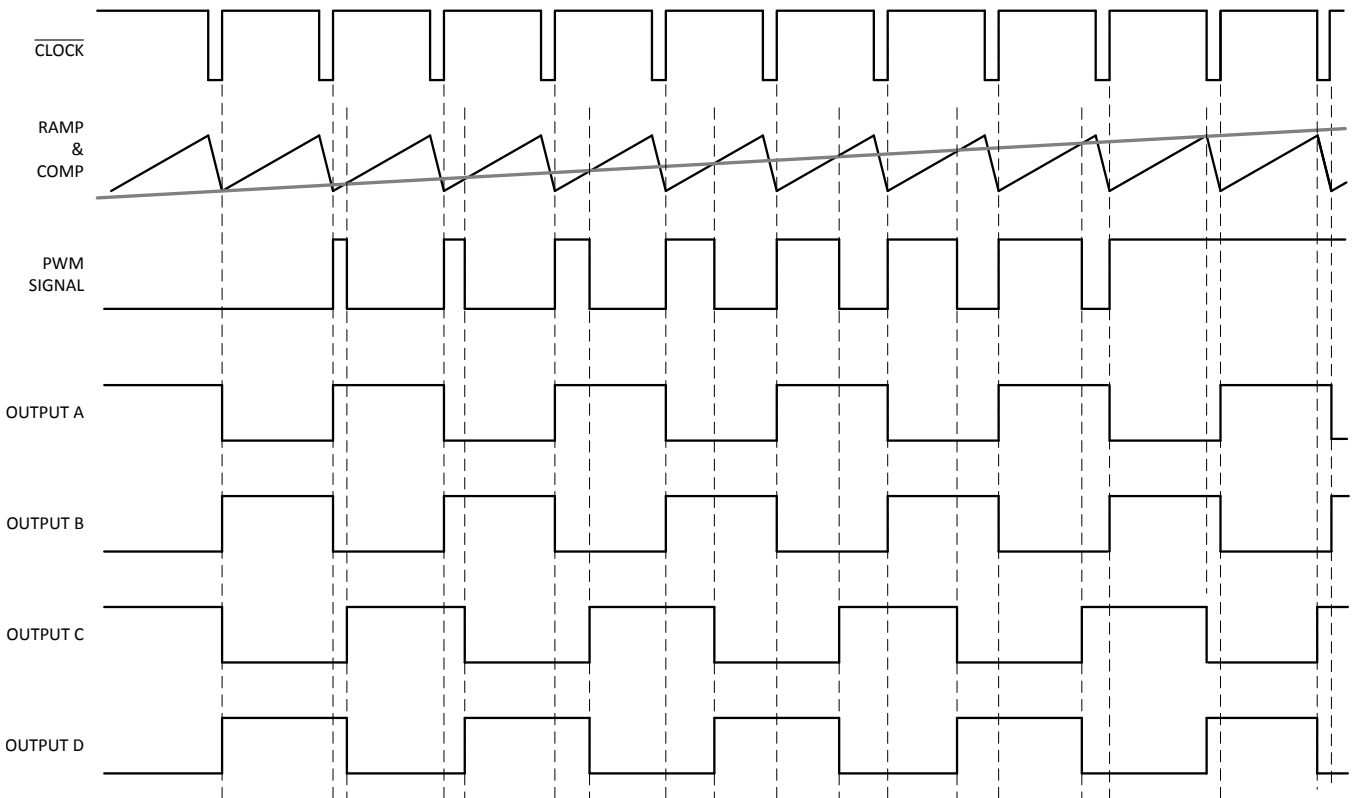

Figure 15. Delay Time Under Varying ADS Voltages



No Output Delay Shown, COMP to RAMP offset not included.

Figure 16. UCC3895 Timing Diagram

8 Application and Implementation

NOTE

Information in the following applications sections is not part of the TI component specification, and TI does not warrant its accuracy or completeness. TI's customers are responsible for determining suitability of components for their purposes. Customers should validate and test their design implementation to confirm system functionality.

8.1 Application Information

A simplified electrical diagram of this converter is shown in [Figure 18](#). The controller device is located on the primary side of converter to allow easy bias power generation.

The power stage includes primary side MOSFETs, QA, QB, QC and QD. Diode rectification is used here for simplicity but synchronous rectification is also possible and is described in application notes [SLUU109 Using the UCC3895 in a Direct Control Driven Synchronous Rectifier Applications](#) and [SLUA287 Control Driven Synchronous Rectifiers In Phase Shifted Full Bridge Converters](#). The centre-tapped rectifier scheme with L-C output filter is a popular choice for the 12-V output converters in server power supplies.

The major waveforms of the phase-shifted converter during normal operation are shown in [Figure 17](#). The upper four waveforms show the output drive signals of the controller. Current, I_{PR} , is the current flowing through the primary winding of the power transformer. The bottom two waveforms show the voltage at the output inductor, $V_{L_{OUT}}$, and the current through the output inductor, $I_{L_{OUT}}$. ZVS is an important feature for high input voltage converters in reducing switching losses associated with the internal parasitic capacitances of power switches and transformers. The controller ensures ZVS conditions over the entire load current range by adjusting the delay time between the primary MOSFETs switching in the same leg in accordance to the load variation. At light loads the output of the error amplifier (EAOUT) will drop below the threshold of the No-Load Comparator and the controller will enter a pulse skipping mode.

Application Information (continued)

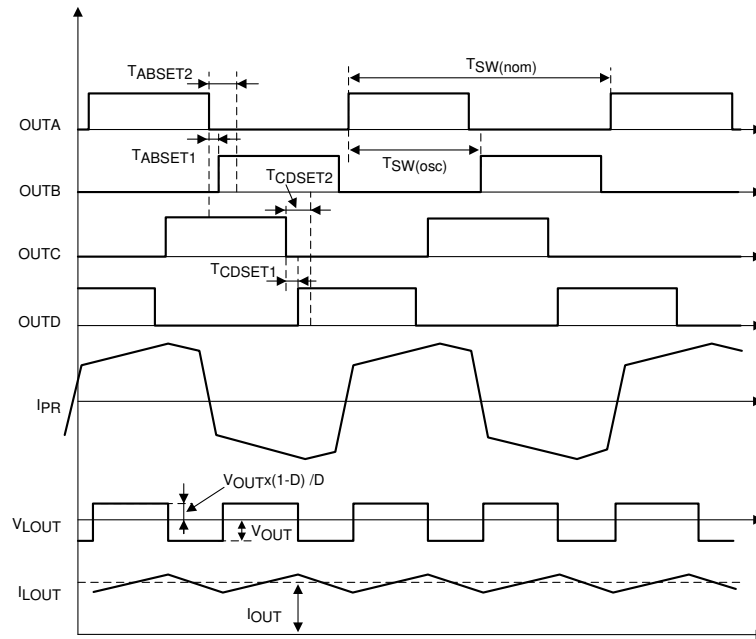

Figure 17. Major Waveforms of Phase-Shifted Converter

8.2 Typical Application

A typical application for the UCC3895 device is a controller for a phase-shifted full-bridge converter that converts a 390-V_{DC} input to a regulated 12-V output.

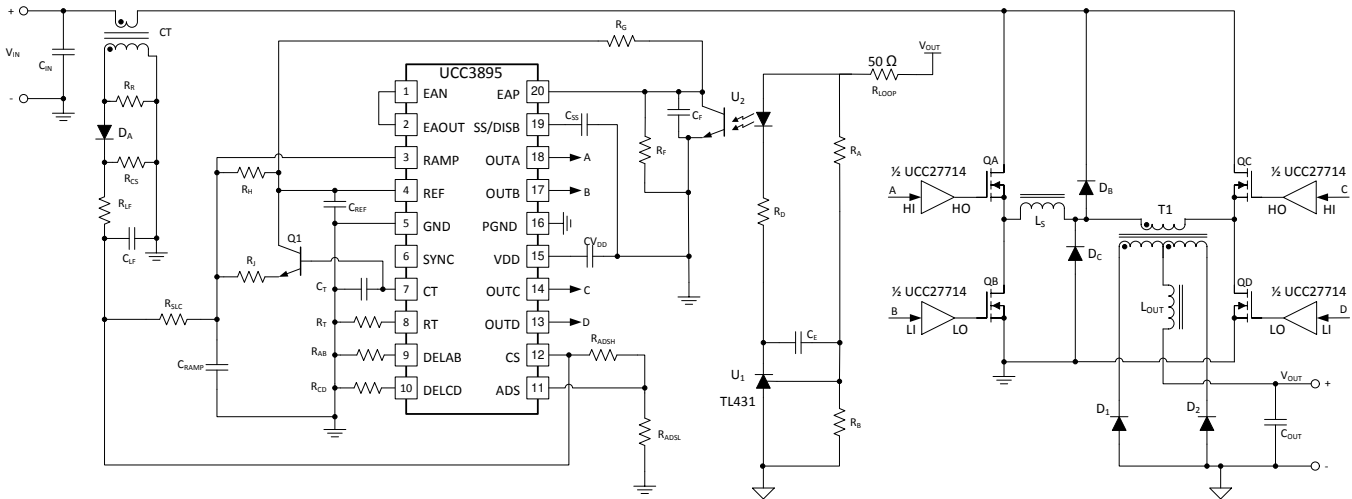

Figure 18. UCC3895 Typical Application

8.2.1 Design Requirements

Table 1 lists the requirements for this application.

Table 1. UCC3895 Typical Application Design Requirements

PARAMETER	TEST CONDITIONS	MIN	TYP	MAX	UNIT		
INPUT CHARACTERISTICS							
V _{IN}	DC input voltage range	370	390	410	V		
I _{IN(max)}	Maximum input current	V _{IN} = 370 V _{DC} to 410 V _{DC}		2	A		
OUTPUT CHARACTERISTICS							
V _{OUT}	Output voltage	V _{IN} = 370 V _{DC} to 410 V _{DC}		11.4	12	12.6	V
I _{OUT}	Output current	V _{IN} = 370 V _{DC} to 410 V _{DC}				50	A
	Output voltage transient	90% load step		600			mV
P _{OUT}	Continuous output power	V _{IN} = 370 V _{DC} to 410 V _{DC}				600	W
	Load regulation	V _{IN} = 370 V _{DC} to 410 V _{DC} , I _{OUT} = 5 A to 50 A				140	mV
	Line regulation	V _{IN} = 370 V _{DC} to 410 V _{DC} , I _{OUT} = 5 A to 50 A				140	mV
	Output ripple voltage	V _{IN} = 370 V _{DC} to 410 V _{DC} , I _{OUT} = 5 A to 50 A				200	mV
SYSTEM							
F _{SW}	Switching frequency			100			kHz
	Full-load efficiency	V _{IN} = 370 V _{DC} to 410 V _{DC} , P _{OUT} = 500 W		92%	93%		

8.2.2 Detailed Design Procedure

The phase-shifted full-bridge converter topology is well suited to high-power server applications. This is because the phase-shifted, full-bridge converter can obtain zero-voltage switching on the primary side of the converter, reducing switching losses and EMI and increasing overall efficiency. This is a review of the design of a 600-W, phase-shifted, full-bridge converter for one of these power systems using TI's UCC3895 device. The review is based on typical values. In a production design, the values may need to be modified for worst-case conditions.

NOTE

F_{SW} refers to the switching frequency applied to the power transformer. The oscillator on the UCC2895 is set to $2 \times F_{SW}$. The output inductor also experiences a switching frequency which is $2 \times F_{SW}$.

8.2.2.1 Power Loss Budget

To meet the efficiency goal a power loss budget needs to be set.

$$P_{BUDGET} = P_{OUT} \times \left(\frac{1-\eta}{\eta} \right) \approx 52W \quad (7)$$

8.2.2.2 Preliminary Transformer Calculations (T1)

Transformer turns ratio (a1):

$$a1 = \frac{N_p}{N_s} \quad (8)$$

The voltage drop across the $R_{DS(on)}$ of the primary side FETs is negligible. We assume a 0.5-V forward voltage drop in the output rectifiers.

$$V_f = 0.45V \quad (9)$$

Select transformer turns based on 70% duty cycle (D_{MAX}) at minimum specified input voltage. This will give some room for dropout if a PFC front end is used.

$$a1 = \frac{N_p}{N_s} \quad (10)$$

$$a1 = \frac{V_{INMIN} \times D_{MAX}}{V_{OUT} - V_f} \approx 21 \quad (11)$$

Turns ratio rounded to the nearest whole turn.

$$a1 = 21 \quad (12)$$

Calculated typical duty cycle (D_{TYP}) based on average input voltage.

$$D_{TYP} = \frac{(V_{OUT} + V_f) \times a1}{V_{IN}} \approx 0.66 \quad (13)$$

Output inductor peak-to-peak ripple current is set to 20% of the output current.

$$\Delta I_{L_{OUT}} = \frac{P_{OUT} \times 0.2}{V_{OUT}} = 10A \quad (14)$$

Care must be taken in selecting the correct amount of magnetizing inductance (L_{MAG}). The following equations calculate the minimum magnetizing inductance of the primary of the transformer (T1) to ensure the converter operates in current-mode control. As L_{MAG} reduces, the increasing magnetizing current becomes an increasing proportion of the signal at the CS pin. If the magnetizing current increases enough it can swamp out the current sense signal across R_{CS} and the converter will operate increasingly as if it were in voltage mode control rather than current mode.

$$L_{MAG} \geq \frac{V_{IN} \times (1 - D_{TYP})}{\frac{\Delta I_{LOUT} \times 0.5}{a1} \times 2 \times F_{SW}} \approx 2.78 \text{mH} \tag{15}$$

Figure 19 shows the transformer primary and secondary currents during normal operation.

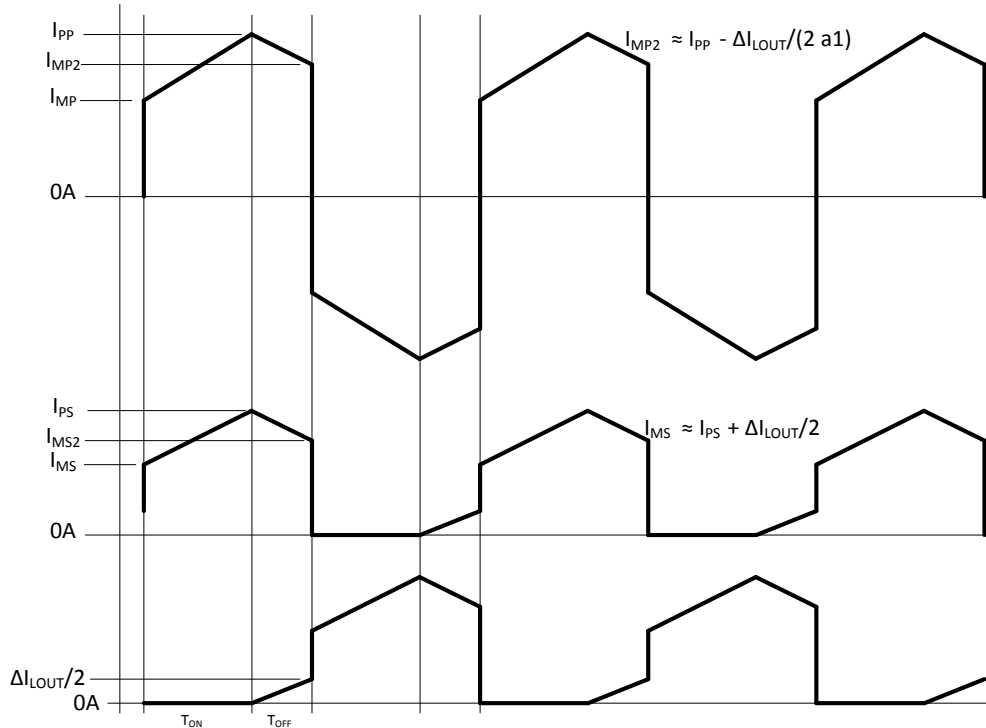

Figure 19. T1 Primary and Secondary Currents

Calculate T1 secondary RMS current (I_{SRMS}):

$$I_{PS} = \frac{P_{OUT}}{V_{OUT}} + \frac{\Delta I_{LOUT}}{2} \approx 55 \text{ A} \quad (16)$$

$$I_{MS} = \frac{P_{OUT}}{V_{OUT}} - \frac{\Delta I_{LOUT}}{2} \approx 45 \text{ A} \quad (17)$$

$$I_{MS2} = I_{PS} - \frac{\Delta I_{LOUT}}{2} \approx 50 \text{ A} \quad (18)$$

Secondary RMS current (I_{SRMS1}) when energy is being delivered to the secondary: (OUTA = OUTD = HI or OUTB = OUTC = HI).

$$I_{SRMS1} = \sqrt{\left(\frac{D_{MAX}}{2}\right) \left[I_{PS} \times I_{MS} + \frac{(I_{PS} - I_{MS})^2}{3} \right]} \approx 29.6 \text{ A} \quad (19)$$

Secondary RMS current (I_{SRMS2}) during freewheeling period: (OUTA = OUTC = HI or OUTB = OUTD = HI).

$$I_{SRMS2} = \sqrt{\left(\frac{1 - D_{MAX}}{2}\right) \left[I_{PS} \times I_{MS2} + \frac{(I_{PS} - I_{MS2})^2}{3} \right]} \approx 20.3 \text{ A} \quad (20)$$

Secondary RMS current (I_{SRMS3}) caused by the negative current in the opposing winding during freewheeling period, please refer to [Figure 19](#).

$$I_{SRMS3} = \frac{\Delta I_{LOUT}}{2} \sqrt{\left(\frac{1 - D_{MAX}}{2 \times 3}\right)} \approx 1.1 \text{ A} \quad (21)$$

Total secondary RMS current (I_{SRMS}):

$$I_{SRMS} = \sqrt{I_{SRMS1}^2 + I_{SRMS2}^2 + I_{SRMS3}^2} \approx 36.0 \text{ A} \quad (22)$$

Calculate T1 Primary RMS Current (I_{PRMS}):

$$\Delta I_{LMAG} = \frac{V_{INMIN} \times D_{MAX}}{L_{MAG} \times 2 \times F_{SW}} \approx 0.47 \text{ A} \quad (23)$$

$$I_{PP} = \left(\frac{P_{OUT}}{V_{OUT} \times \eta} + \frac{\Delta I_{LOUT}}{2} \right) \frac{1}{a1} + \Delta I_{LMAG} \approx 3.3 \text{ A} \quad (24)$$

$$I_{MP} = \left(\frac{P_{OUT}}{V_{OUT} \times \eta} - \frac{\Delta I_{LOUT}}{2} \right) \frac{1}{a1} + \Delta I_{LMAG} \approx 2.8 \text{ A} \quad (25)$$

$$I_{PRMS1} = \sqrt{D_{MAX} \left[I_{PP} \times I_{MP} + \frac{(I_{PP} - I_{MP})^2}{3} \right]} \approx 2.5 \text{ A} \quad (26)$$

$$I_{MP2} = I_{PP} - \left(\frac{\Delta I_{LOUT}}{2} \right) \frac{1}{a1} \approx 3.0 \text{ A} \quad (27)$$

T1 Primary RMS (I_{PRMS1}) current when energy is being delivered to the secondary.

$$I_{PRMS1} = \sqrt{(D_{MAX}) \left[I_{PP} \times I_{MP} + \frac{(I_{PP} - I_{MP})^2}{3} \right]} \approx 2.5 \text{ A} \quad (28)$$

T1 Primary RMS (I_{PRMS2}) current when the converter is free wheeling.

$$I_{PRMS2} = \sqrt{(1 - D_{MAX}) \left[I_{PP} \times I_{MP2} + \frac{(I_{PP} - I_{MP2})^2}{3} \right]} \approx 1.7 \text{ A} \quad (29)$$

Total T1 primary RMS current (I_{PRMS}):

$$I_{PRMS} = \sqrt{I_{PRMS1}^2 + I_{PRMS2}^2} \approx 3.1 \text{ A} \quad (30)$$

We select a transformer with the following specifications:

$$a1 = 21 \quad (31)$$

$$L_{MAG} = 2.8 \text{ mH} \quad (32)$$

Transformer Primary DC resistance:

$$DCR_p = 0.215 \Omega \quad (33)$$

Transformer Secondary DC resistance:

$$DCR_s = 0.58 \Omega \quad (34)$$

Estimated transformer core losses (P_{T1}) are twice the copper loss.

NOTE

This is just an estimate and the total losses may vary based on magnetic design.

$$P_{T1} \approx 2 \times (I_{PRMS}^2 \times DCR_p + 2 \times I_{SRMS}^2 \times DCR_s) \approx 7.0 \text{ W} \quad (35)$$

Calculate remaining power budget:

$$P_{BUDGET} = P_{BUDGET} - P_{T1} \approx 45 \text{ W} \quad (36)$$

8.2.2.3 QA, QB, QC, QD FET Selection

In this design to meet efficiency and voltage requirements 20 A, 650 V, CoolMOS FETs from Infineon are chosen for QA..QD.

FET drain to source on resistance:

$$R_{ds(on)QA} = 0.220 \Omega \quad (37)$$

FET Specified C_{OSS} :

$$C_{OSS_QA_SPEC} = 780 \text{ pF} \quad (38)$$

Voltage across drain-to-source (V_{dsQA}) where C_{OSS} was measured, data sheet parameter:

$$V_{dsQA} = 25 \text{ V} \quad (39)$$

Calculate average C_{OSS} [2]:

$$C_{OSS_QA_AVG} = C_{OSS_QA_SPEC} \sqrt{\frac{V_{dsQA}}{V_{INMAX}}} \approx 193 \text{ pF} \quad (40)$$

QA FET gate charge:

$$QA_g = 15 \text{ nC} \quad (41)$$

Voltage applied to FET gate to activate FET:

$$V_g = 12 \text{ V} \quad (42)$$

Calculate QA losses (P_{QA}) based on $R_{ds(on)QA}$ and gate charge (QA_g):

$$P_{QA} = I_{PRMS}^2 \times R_{DS(on)QA} + 2 \times QA_g \times V_g \times f_{SW} \approx 2.1 \text{ W} \quad (43)$$

Recalculate power budget:

$$P_{BUDGET} = P_{BUDGET} - 4 \times P_{QA} \approx 36.6 \text{ W} \quad (44)$$

8.2.2.4 Selecting L_S

Calculating the value of the shim inductor (L_S) is based on the amount of energy required to achieve zero voltage switching. This inductor needs to be able to deplete the energy from the parasitic capacitance at the switch node. The following equation selects L_S to achieve ZVS at 100% load down to 50% load based on the primary FET's average total C_{OSS} at the switch node.

NOTE

The actual parasitic capacitance at the switched node may differ from the estimate and L_S may have to be adjusted accordingly.

$$L_S \geq \left(2 \times C_{OSS_QA_AVG} \right) \frac{V_{INMAX}^2}{\left(\frac{I_{PP}}{2} - \frac{\Delta I_{LOUT}}{2 \times a1} \right)^2} - L_{LK} \approx 26 \mu H \quad (45)$$

$$L_S = 26 \mu H \quad (46)$$

Typical shim inductor DC resistance:

$$DCR_{L_S} = 27 m\Omega \quad (47)$$

Estimate L_S power loss (P_{L_S}) and readjust remaining power budget:

$$P_{L_S} = 2 \times I_{PRMS}^2 \times DCR_{L_S} \approx 0.5 W \quad (48)$$

$$P_{BUDGET} = P_{BUDGET} - P_{L_S} \approx 36.1 W \quad (49)$$

8.2.2.5 Selecting Diodes D_B and D_C

There is a potential for high voltage ringing on the secondary rectifiers, caused by the difference in current between the transformer and the shim inductor when the transformer comes out of freewheeling. Diodes D_B and D_C provide a path for this current and prevent any ringing by clamping the transformer primary to the primary side power rails. Normally these diodes do not dissipate much power but they should be sized to carry the full primary current. The worst case power dissipated in these diodes is:

$$P = 0.5 \times L_S \times I_{PRMS}^2 \times F_{SW} \quad (50)$$

The diodes should be ultra-fast types and rated for the input voltage of the converter – V_{IN} (410 VDC in this case).

A MURS360 part is suitable at this power level.

8.2.2.6 Output Inductor Selection (L_{OUT})

Inductor L_{OUT} is designed for 20% inductor ripple current ($\Delta I_{L_{OUT}}$):

$$\Delta I_{L_{OUT}} = \frac{P_{OUT} \times 0.2}{V_{OUT}} = \frac{600 \text{ W} \times 0.2}{12 \text{ V}} \approx 10 \text{ A} \quad (51)$$

$$L_{OUT} = \frac{V_{OUT} \times (1 - D_{TYP})}{\Delta I_{L_{OUT}} \times 2 \times f_{SW}} \approx 2 \mu\text{H} \quad (52)$$

Calculate output inductor RMS current ($I_{L_{OUT_RMS}}$):

$$I_{L_{OUT_RMS}} = \sqrt{\left(\frac{P_{OUT}}{V_{OUT}}\right)^2 + \left(\frac{\Delta I_{L_{OUT}}}{\sqrt{3}}\right)^2} = 50.3 \text{ A} \quad (53)$$

$$L_{OUT} = 2 \mu\text{H} \quad (54)$$

Typical output inductor DC resistance:

$$DCR_{L_{OUT}} = 750 \mu\Omega \quad (55)$$

Estimate output inductor losses ($P_{L_{OUT}}$) and recalculate power budget. Note $P_{L_{OUT}}$ is an estimate of inductor losses that is twice the copper loss. Note this may vary based on magnetic manufactures. It is advisable to double check the magnetic loss with the magnetic manufacture.

$$P_{L_{OUT}} = 2 \times I_{L_{OUT_RMS}}^2 \times DCR_{L_{OUT}} \approx 3.8 \text{ W} \quad (56)$$

$$P_{BUDGET} = P_{BUDGET} - P_{L_{OUT}} \approx 32.8 \text{ W} \quad (57)$$

8.2.2.7 Output Capacitance (C_{OUT})

The output capacitor is selected based on holdup and transient (V_{TRAN}) load requirements.

Time it takes L_{OUT} to change 90% of its full load current:

$$t_{HU} = \frac{L_{OUT} \times P_{OUT} \times 0.9}{V_{OUT}} = 7.5 \mu s \quad (58)$$

During load transients most of the current will immediately go through the capacitors equivalent series resistance (ESR_{COUT}). The following equations are used to select ESR_{COUT} and C_{OUT} based on a 90% load step in current. The ESR is selected for 90% of the allowable transient voltage (V_{TRAN}), while the output capacitance (C_{OUT}) is selected for 10% of V_{TRAN} .

$$ESR_{COUT} \leq \frac{V_{TRAN} \times 0.9}{P_{OUT} \times 0.9} = 12 m\Omega \quad (59)$$

$$C_{OUT} \geq \frac{P_{OUT} \times 0.9 \times t_{HU}}{V_{TRAN} \times 0.1} \approx 5.6 mF \quad (60)$$

Before selecting the output capacitor, the output capacitor RMS current (I_{COUT_RMS}) must be calculated.

$$I_{COUT_RMS} = \frac{\Delta I_{L_OUT}}{\sqrt{3}} \approx 5.8 A \quad (61)$$

To meet the design requirements five 1500- μF , aluminum electrolytic capacitors are chosen for the design from United Chemi-Con™, part number EKY-160ELL152MJ30S. These capacitors have an ESR of 31 m Ω .

Number of output capacitors:

$$n = 5 \quad (62)$$

Total output capacitance:

$$C_{OUT} = 1500 \mu F \times n \approx 7500 \mu F \quad (63)$$

Effective output capacitance ESR:

$$ESR_{COUT} = \frac{31 m\Omega}{n} = 6.2 m\Omega \quad (64)$$

Calculate output capacitor loss (P_{COUT}):

$$P_{COUT} = I_{COUT_RMS}^2 \times ESR_{COUT} \approx 0.21 W \quad (65)$$

Recalculate remaining Power Budget:

$$P_{BUDGET} = P_{BUDGET} - P_{COUT} \approx 32.6 W \quad (66)$$

8.2.2.8 Select Rectifier Diodes

Selecting the rectifier diodes begins with determining the voltage and current ratings necessary. In this case the peak diode reverse voltage is given by:

$$V_r = 2 \times \frac{V_{IN_MAX}}{a1} \approx 38 V \quad (67)$$

The average output diode current is given by:

$$I_f = \frac{I_{OUT_avg}}{2} \approx 30 A \quad (68)$$

For this design we select dual 40-A, 45-V Schottky diodes type STPS40L45CT. This is a dual diode and we connect both of the diodes in parallel for current sharing. Each diode in the package will carry approximately half of the I_f calculated above, or about 15 A. The forward voltage drop of these diodes at maximum output current will be typically 0.45 V.

The power loss in the output rectifiers is dominated by the $V_f I_f$ product.

The loss in each dual diode package is given by:

$$P_{\text{Diode}} = V_f \times I_f \approx 13.5 \text{ W} \quad (69)$$

The device will require a heatsink to keep its junction temperature at a reasonable level.

The heatsink thermal resistance will have to be less than:

$$R_{\text{TH_HSK_D}} = \frac{T_{j_max} - T_A}{P_{\text{Diode}}} - R_{\text{TH_JC}} \approx 4.5^\circ \text{ CW}^{-1} \quad (70)$$

where $T_{j_max} = 125^\circ \text{C}$, $T_A = 50^\circ \text{C}$, and $R_{\text{TH_JC}} = 0.8^\circ \text{ CW}^{-1}$.

A typical heatsink with this thermal resistance would have dimensions 63.5 mm x 42 mm x 25 mm.

Recalculate the power budget.

$$P_{\text{BUDGET}} = P_{\text{BUDGET}} - 2 \times P_{\text{Diode}} \approx 5.6 \text{ W} \quad (71)$$

8.2.2.9 Input Capacitance (C_{IN})

The input voltage in this design is 390 V_{DC}, which is generally fed by the output of a PFC boost pre-regulator. The input capacitance is generally selected based on holdup and ripple requirements.

NOTE

The delay time needed to achieve ZVS can act as a duty cycle clamp (D_{CLAMP}).

Calculate tank frequency:

$$f_R = \frac{1}{2\pi\sqrt{L_S \times (2 \times C_{OSS_QA_AVG})}} \quad (72)$$

Estimated delay time:

$$t_{DELAY} = \frac{2}{f_R \times 4} \approx 314 \text{ ns} \quad (73)$$

Effective duty cycle clamp (D_{CLAMP}):

$$D_{CLAMP} = \left(\frac{1}{2 \times f_{SW}} - t_{DELAY} \right) \times 2 \times f_{SW} = 94\% \quad (74)$$

V_{DROP} is the minimum input voltage where the converter can still maintain output regulation. The converter's input voltage would only drop down this low during a brownout or line-drop condition if this converter was following a PFC pre-regulator.

$$V_{DROP} = \frac{a1 \times (V_{OUT} + V_f)}{D_{CLAMP}} \approx 278 \text{ V} \quad (75)$$

C_{IN} was calculated based on one line cycle of holdup:

$$C_{IN} \geq \frac{2 \times P_{OUT} \times \frac{1}{60 \text{ Hz}}}{(V_{IN}^2 - V_{DROP}^2)} \approx 364 \mu\text{F} \quad (76)$$

Calculate high frequency input capacitor RMS current (I_{CINRMS}).

$$I_{CINRMS} = \sqrt{I_{PRMS1}^2 - \left(\frac{P_{OUT}}{V_{INMIN} \times a1} \right)^2} = 1.8 \text{ A} \quad (77)$$

To meet the input capacitance and RMS current requirements for this design a 330- μF capacitor was chosen from Panasonic part number EETHC2W331EA.

$$C_{IN} = 330 \mu\text{F} \quad (78)$$

This capacitor has a high frequency (ESR_{CIN}) of 150 m Ω , measured with an impedance analyzer at 200 kHz.

$$ESR_{CIN} = 0.150 \Omega \quad (79)$$

Estimate C_{IN} power dissipation (P_{CIN}):

$$P_{CIN} = I_{CINRMS}^2 \times ESR_{CIN} = 0.5 \text{ W} \quad (80)$$

Recalculate remaining power budget:

$$P_{BUDGET} = P_{BUDGET} - P_{CIN} \approx 5.0 \text{ W} \quad (81)$$

There is roughly 5.0 W left in the power budget left for the current sensing network, and biasing the control device and all resistors supporting the control device.

8.2.2.10 Current Sense Network (CT, R_{CS}, R_R, D_A)

The CT chosen for this design has a turns ratio (CT_{RAT}) of 100:1.

$$CT_{RAT} = \frac{I_P}{I_S} = 100 \quad (82)$$

Calculate nominal peak current (I_{P1}) at V_{INMIN}:

Peak primary current:

$$I_{P1} = \left(\frac{P_{OUT}}{V_{OUT} \times \eta} + \frac{\Delta I_{L_{OUT}}}{2} \right) \frac{1}{a1} + \frac{V_{INMIN} \times D_{MAX}}{L_{MAG} \times 2 \times F_{SW}} \approx 3.3 \text{ A} \quad (83)$$

The CS pin voltage where peak current limit will trip.

$$V_P = 2 \text{ V} \quad (84)$$

Calculate current sense resistor (R_{CS}) and leave 300 mV for slope compensation. Include a 1.1 factor for margin:

$$R_{CS} = \frac{V_P - 0.3 \text{ V}}{\frac{I_{P1}}{CT_{RAT}} \times 1.1} \approx 47 \Omega \quad (85)$$

Select a standard resistor for R_{CS}:

$$R_{CS} = 47 \Omega \quad (86)$$

Estimate power loss for R_{CS}:

$$P_{RCS} = \left(\frac{I_{PRMS1}}{CT_{RAT}} \right)^2 \times R_{CS} \approx 0.03 \text{ W} \quad (87)$$

Calculate maximum reverse voltage (V_{DA}) on D_A:

$$V_{DA} = V_P \frac{D_{CLAMP}}{1 - D_{CLAMP}} \approx 29.8 \text{ V} \quad (88)$$

Estimate D_A power loss (P_{DA}):

$$P_{DA} = \frac{P_{OUT} \times 0.6 \text{ V}}{V_{INMIN} \times \eta \times CT_{RAT}} \approx 0.01 \text{ W} \quad (89)$$

Calculate reset resistor R_R:

Resistor R_R is used to reset the current sense transformer CT.

$$R_R = 100 \times R_{CS} = 4.7 \text{ k}\Omega \quad (90)$$

Resistor R_{LF} and capacitor C_{LF} form a low pass filter for the current sense signal (Pin 15). For this design we chose the following values. This filter has a low frequency pole (f_{LFP}) at 482 kHz. This should work for most applications but may be adjusted to suit individual layouts and EMI present in the design.

$$R_{LF} = 1\text{k}\Omega \quad (91)$$

$$C_{LF} = 330\text{pF} \quad (92)$$

$$f_{LFP} = \frac{1}{2\pi f \times R_{LF} \times C_{LF}} = 482\text{kHz} \quad (93)$$

The UCC3895 REF output (Pin 4) needs a high frequency bypass capacitor to filter out high frequency noise. The maximum amount of capacitance allowed is given in the [Recommended Operating Conditions](#).

$$C_{REF} = 1\ \mu\text{F} \quad (94)$$

The voltage amplifier reference voltage (Pin 2, EA+) can be set with a voltage divider (R_1 , R_2), for this design example, the error amplifier reference voltage (V_1) will be set to 2.5 V. Select a standard resistor value for R_1 and then calculate resistor value R_2 .

UCC3895 reference voltage:

$$V_{REF} = 5\text{V} \quad (95)$$

Set voltage amplifier reference voltage:

$$V_1 = 2.5\text{V} \quad (96)$$

$$R_1 = 2.37\text{k}\Omega \quad (97)$$

$$R_2 = \frac{R_1 \times (V_{REF} - V_1)}{V_1} = 2.37\text{k}\Omega \quad (98)$$

Voltage divider formed by resistor R_3 and R_4 are chosen to set the DC output voltage (V_{OUT}) at Pin 3 (EA-).

Select a standard resistor for R_3 :

$$R_3 = 2.37\text{k}\Omega \quad (99)$$

Calculate R_4 :

$$R_4 = \frac{R_3 \times (V_{OUT} - V_1)}{V_1} \approx 9\text{k}\Omega \quad (100)$$

Then choose a standard resistor for R_4 :

$$R_4 = \frac{R_3 \times (V_{OUT} - V_1)}{V_1} \approx 9.09\text{k}\Omega \quad (101)$$

8.2.2.10.1 Output Voltage Setpoint

Peak current mode control is chosen for this design and a TL431 (U_1) acts as the output voltage error amplifier. It has a 2.5-V internal reference and we want to regulate V_{OUT} to 12 V. We set R_B , the lower resistor of the output voltage divider chain to 10 k Ω . R_A the upper resistor is given by:

$$R_A = R_B \left(\frac{V_{OUT}}{V_{REF}} - 1 \right) = 38\text{ k}\Omega \quad (102)$$

It is possible, but not necessary, to add a small resistor, R_{LOOP} , in series with the feedback network as a signal injection point for loop stability tests, R_{LOOP} .

The output of U_1 is transferred across the isolation barrier by the optocoupler U_2 and fed into the EAP pin of the UCC3895 as a current demand signal. The UCC2895 internal error amplifier is configured as a voltage follower by connecting EAN to EAOUT.

8.2.2.10.2 Voltage Loop Compensation

We choose a standard configuration for a TL431 / optocoupler based feedback network. Type 2 loop compensation is appropriate for a design using peak current mode control. First we set the DC operating points for the TL431 (U1) and the optocoupler (U2).

We assume that the optocoupler (U2) has a current transfer ratio (CTR) of 1 and choose to operate it at a maximum LED current, I_F of 10 mA. R_D is then given by:

$$R_D = \frac{V_{OUT} - V_F - V_{k_MIN}}{I_F} \approx 820 \Omega \quad (103)$$

We set the parallel combination of R_G and R_F to 2.4 k Ω for a nominal 10-dB gain for output perturbations via the direct path from R_D to the optocoupler diode. This path exists in parallel with the path through R_A and the TL431. The direct path is important at frequencies where the gain of the TL431 integrator has fallen to 0 dB.

R_G and R_F form a potential divider whose function is to keep the EAP pin within the upper limit of its common mode input range ($V_{CM_MAX} = 3.6$ V) when there is no current in the photo-transistor. R_G is connected to VREF and this constraint on the voltage at the EAP pin gives:

$$R_G = R_F \frac{V_{REF}}{V_{CM_MAX}} - 1 = 0.39 R_F \quad (104)$$

Since we know the parallel value of R_F and R_G and their ratio (R_F/R_G), we calculate R_F as follows:

$$R_F = R_F \parallel R_G \frac{1.39}{0.39} \approx 8.6 k\Omega \quad (105)$$

and

$$R_G = 0.39 R_F = 3.3 k\Omega \quad (106)$$

At low frequencies the gain is dominated by the response of the TL431 error amplifier which is configured as a pure integrator. The TL431 has a typical open loop gain of about 60 dB at DC, which decreases at the normal –20 dB per decade. Its gain will be 0 dB when the impedance of CE falls to that of R_A . Even though the TL431 gain has fallen to 0 dB, the system still has 10-dB gain due to the direct path through R_D .

We put the zero due to capacitor C_E and resistor R_A at the desired 0-dB gain frequency of 2 kHz. Since R_A is already selected from V_{OUT} setpoint considerations we calculate C_E as follows:

$$C_E = \frac{1}{2\pi 2000 \text{ Hz } 38 k\Omega} \approx 22 \text{ nF} \quad (107)$$

The optocoupler has a 10-dB response through the direct path, to perturbations on V_{OUT} . At higher frequencies the capacitance at the collector of the optocoupler (C_F) forms a pole with the resistor in series with the optocoupler LED. The gain then rolls off in half a decade to reach 0 dB. With $C_F = 68$ nF this pole is at about 2.8 kHz.

Having chosen the component values in the feedback path around the TL431 we can draw a Bode Plot of the V_{OUT} to EAP transfer function $G_C(f)$.

The control to output transfer function of the power train is approximated by:

$$G_{CO}(f) = \frac{\Delta V_{OUT}}{\Delta V_C} \approx a1 \times CT_{RAT} \times \frac{R_{LOAD}}{R_{CS}} \times \left(\frac{1 + s ESR_{COOUT} \times C_{OUT}}{1 + s R_{LOAD} \times C_{OUT}} \right) \times \frac{1}{1 + \frac{s}{s_{PP}} + \left(\frac{s}{s_{PP}} \right)^2}$$

where

- $s = 2\pi jf$ is the complex frequency
- s_{PP} is $F_{SW} / 2 = 50$ kHz in this case
- The overall loop response is then given by $G_C(f)$. $G_C(0)$. (108)

This loop response has a crossover frequency of 7.5 kHz. TI recommends that you check the loop stability of the final design with load transient tests and by checking that the gain and phase margins are sufficient. R_{LOOP} provides a convenient point to inject signals for loop gain and phase measurements. The feedback network may need to be adjusted to achieve satisfactory performance.

8.2.2.10.3 Setting the Switching Frequency

In this design we set the UCC2895 oscillator frequency to 200 kHz to give a switching frequency (F_{SW}) of 100 kHz at the transformer primary. We set $R_T = 82 \text{ k}\Omega$, within the limits given in the *RT (Oscillator Timing Resistor)* section and rearrange Equation 2 to find the needed value of C_T .

$$C_T = \frac{48 \times [t_{OSC} - 120 \text{ ns}]}{5 \times R_T} \approx 560 \text{ pF} \quad (109)$$

This value is within the limits for C_T in the *CT (Oscillator Timing Capacitor)* section.

8.2.2.10.4 Soft Start

$$I_{RT} = \frac{3 \text{ V}}{R_T} \approx 36 \text{ }\mu\text{A} \quad (110)$$

The UCC3895 has a soft-start function to reduce component stresses during the start-up phase. For this design we set the soft-start time to 50 ms. This time is controlled by the value of the capacitor C_{SS} at the SS/DISB pin and the charging current set by R_T (Equation 4).

$$C_{SS} = I_{RT} \times \frac{t_{SS}}{3.6 \text{ V}} = \frac{3 \text{ V}}{R_T} \times \frac{t_{SS}}{3.6 \text{ V}} \approx 470 \text{ nF} \quad (111)$$

8.2.2.10.5 Setting the Switching Delays

Higher power designs will benefit from the adaptive delays provided by the ADS pin but that feature is not used in this example. Setting $R_{ADSH} = 0 \text{ }\Omega$ defeats the adaptive delay and a fixed value for t_{DELAB} and t_{DELCD} is used. If it is planned to use the adaptive delay feature then the resistor R_{ADSL} should be included in the layout but not populated until delay optimisation is being done on actual hardware.

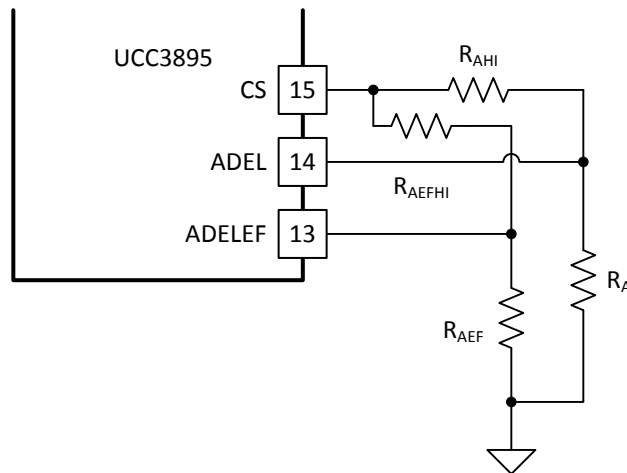

Figure 20. UCC3895 Adaptive Delays

We set the delay times as follows. The resonant frequency of the shim inductor L_S with the stray capacitance at the switched node is given by:

$$f_R = \frac{1}{2\pi \sqrt{L_S \times 2 \times C_{OSS_AVG}}} \approx 1.6 \text{ MHz} \quad (112)$$

Set the initial t_{ABSET} and t_{CDSET} values to half the resonant period

$$t_{DELAY} = 314 \text{ ns} \quad (113)$$

The resistors R_{AB} and R_{CD} are given by a modified version of Equation 5 and Equation 6.

$$R_{AB} = R_{CD} = \frac{(t_{DELAY} - 25 \text{ ns}) \times 0.5 \text{ V}}{25 \times 10^{-12}} \approx 5.6 \text{ k}\Omega \quad (114)$$

It is important to recognise that the delay times set by R_{AB} and R_{CD} are those measured at the device pins. Propagation delays mean that the delay times seen at the primary of the transformer will be different and this is the reason why the delays have to be optimised on actual hardware. Once the prototype is up and running it is recommended that you fine tune t_{ABSET} and t_{CDSET} at light load. Refer to [Figure 21](#) and [Figure 22](#). It is easier to achieve ZVS at the drain of QD than at the drain of QA because the output inductor current reflected in the transformer primary is greater at QD and QC turn-off than it is at QA and QB turn-off.

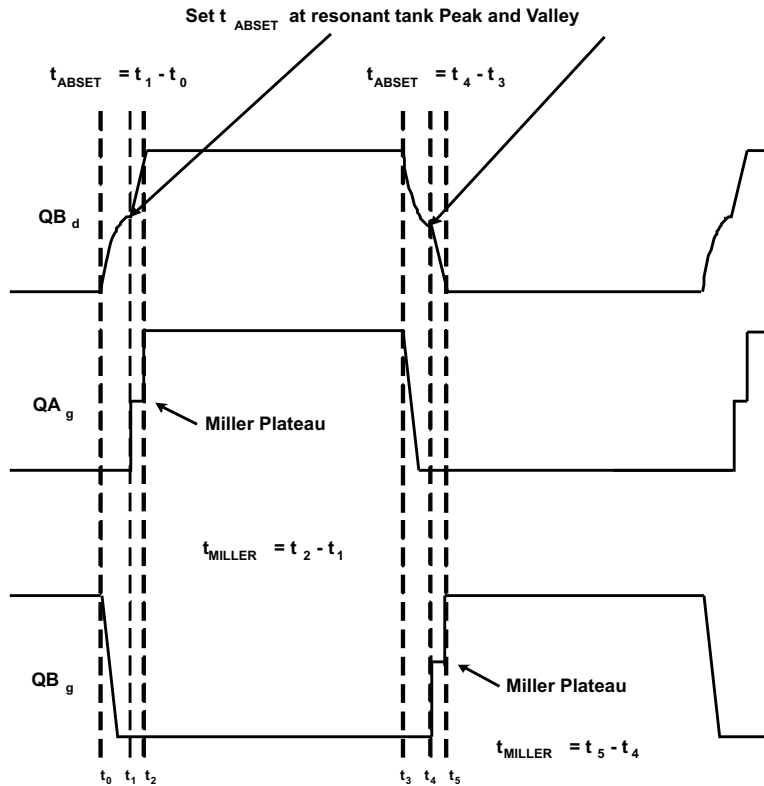

Figure 21. t_{ABSET} to Achieve Valley Switching at Light Loads

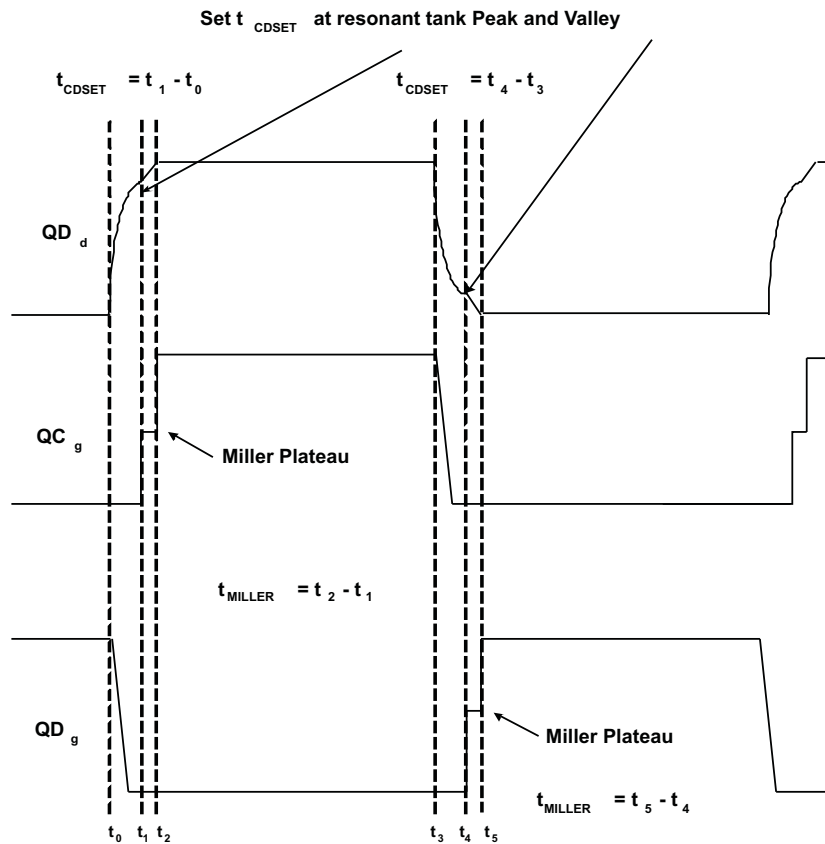

Figure 22. t_{CDSET} to Achieve Valley Switching at Light Loads

8.2.2.10.6 Setting the Slope Compensation

Slope compensation is necessary to stabilise a converter operating in peak current mode at duty cycles greater than 50%. The optimum slope compensation ramp should be half the inductor current ramp downslope during the off time. This slope is calculated as follows:

$$m_e = 0.5 \frac{V_{OUT} \times R_{CS}}{L_{OUT} \times a1 \times CT_{RAT}} = 67 \text{ mV } \mu\text{s}^{-1} \quad (115)$$

The magnetizing current of the power transformer provides part of the compensating ramp and is calculated as follows. The $V_{IN} \times D_{TYP}$ factor takes account of the fact that the slope of the magnetizing current is less at lower input voltages.

$$m_{MAG} = \frac{V_{IN} \times D_{TYP} \times R_{CS}}{L_{MAG} \times CT_{RAT}} \approx 43 \text{ mV } \mu\text{s}^{-1} \quad (116)$$

The added slope compensation ramp is then:

$$m_{SUM} = m_e - m_{MAG} \approx 24 \text{ mV } \mu\text{s}^{-1} \quad (117)$$

The resistor R_{SC} sets the added slope compensation ramp, m_{SUM} and is chosen as follows:

$$R_{SC} = R_{LF} \times \frac{8 \times I_{RT}}{m_{MAG} \times C_T} = 21 \text{ k}\Omega \quad (118)$$

A small AC coupling capacitor is used in the emitter of Q1 to eliminate the need for offset biasing circuitry. $C_C = 1 \text{ nF}$.

The resistor R_{EL} is a DC load resistor for the emitter of Q1. It should have the same value as R_{SC} .

A small capacitor at the RAMP pin input helps suppress high frequency noise, we set $C_{RAMP} = 56\text{ pF}$. Transistor Q1 is a small signal NPN type.

In peak current mode control the RAMP pin receives the current sense signal, plus the slope compensation ramp, through the $510\text{-}\Omega$ resistor R_{RCS} . The $10\text{-k}\Omega$ resistor R_{RB} provides approximately 250-mV offset bias. The value of this resistor may be adjusted up or down to alter the point at which the internal no load comparator trips.

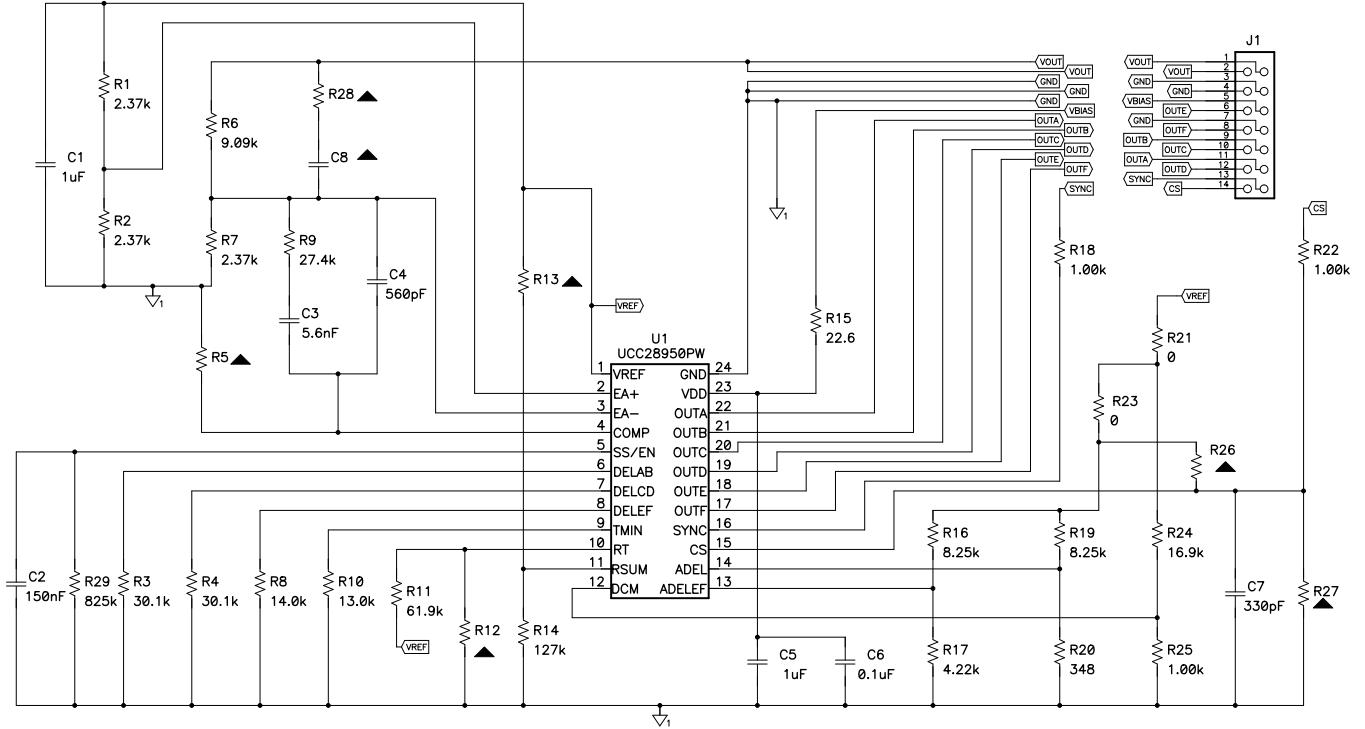

Copyright © 2017, Texas Instruments Incorporated

Figure 23. Daughter Board Schematic

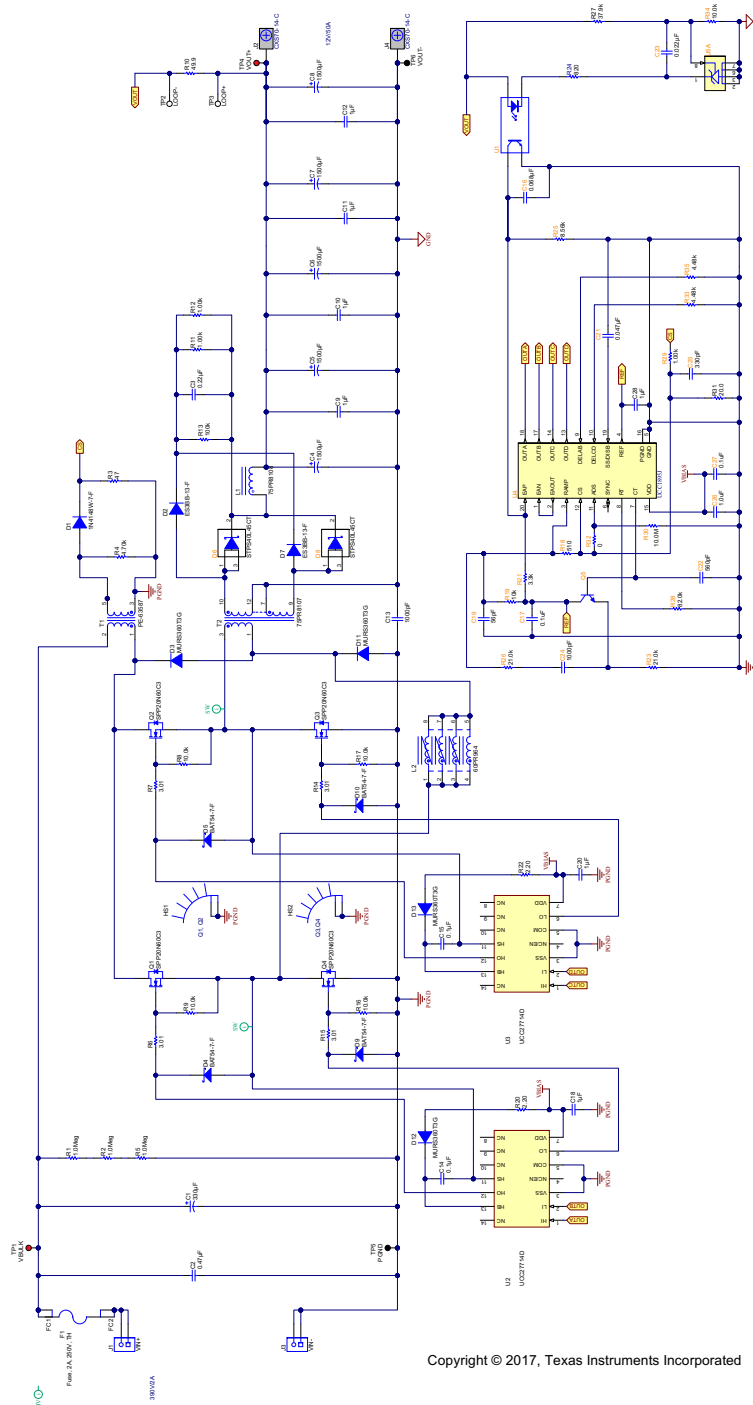

Copyright © 2017, Texas Instruments Incorporated

Figure 24. Power Stage Schematic

8.2.3 Application Curves

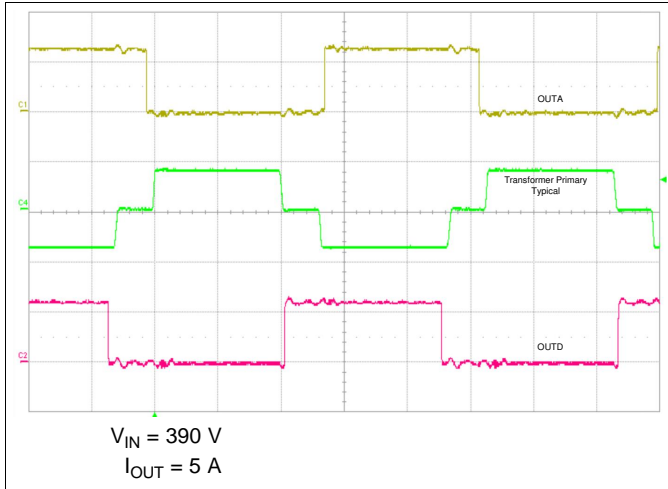

Figure 25. Full Bridge Gate Drives and Primary Switched Nodes

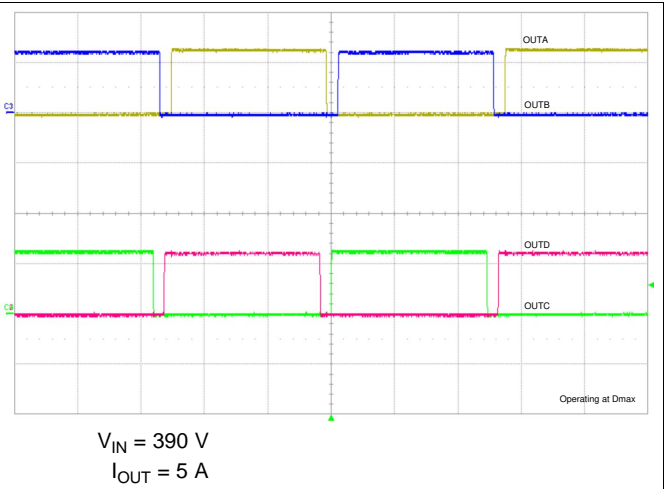

Figure 26. Gate Drive Signals at DMAX

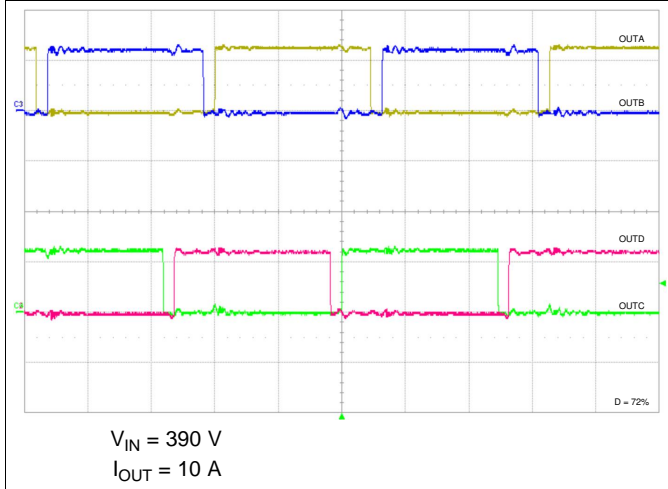

Figure 27. Gate Drive Signals D = 72%

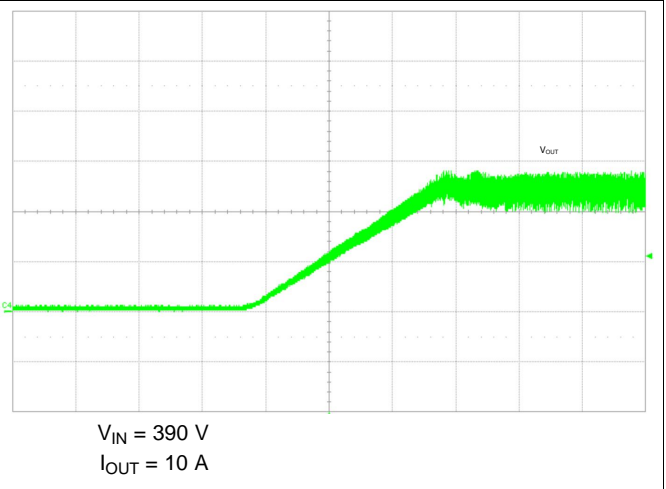

Figure 28. Typical Start-up (Into 50% Full Load)

9 Power Supply Recommendations

The UCC3895 device should be operated from a V_{DD} rail within the limits given in the [Recommended Operating Conditions](#) of this data sheet. To avoid the possibility that the device might stop switching, V_{DD} must not be allowed to fall into the UVLO(off) range. In order to minimize power dissipation in the device, V_{DD} should not be unnecessarily high. Keeping V_{DD} at 12 V is a good compromise between these competing constraints. The gate drive outputs from the UCC3895 device deliver large-current pulses into their loads. This indicates the need for a low-ESR decoupling capacitor to be connected as directly as possible between the V_{DD} and PGND terminals.

TI recommends ceramic capacitors with stable dielectric characteristics over temperature, such as X7R. Avoid capacitors which have a large drop in capacitance with applied DC voltage bias. For example, use a part that has a low-voltage co-efficient of capacitance. The recommended decoupling capacitance is 1 μ F, X7R, with at least a 25-V rating with a 0.1- μ F NPO capacitor in parallel.

10 Layout

10.1 Layout Guidelines

In order to increase the reliability and robustness of the design, it is recommended that the following layout guidelines are followed.

- EAN pin - This is the inverting input to the error amplifier. It is a high impedance pin and is susceptible to noise pickup. Keep tracks from this pin as short as possible.
- EAP pin - This is the non-inverting input to the error amplifier. It is a high impedance pin and is susceptible to noise pickup. Keep tracks from this pin as short as possible.
- EAOUT - pin Keep tracks from this pin as short as possible.
- RAMP, CT, RT, DELAB, DELCD and ADS pins - The components connected to these pins are used to set important operating parameters. Keep these components close to the IC and provide short, low impedance return connections to the GND pin.
- REF pin - Decouple this pin to GND with a good quality ceramic capacitor. A 1- μ F, X7R, 25-V capacitor is recommended. Keep REF PCB tracks as far away as possible from sources of switching noise.
- SYNC pin - This pin is essentially a digital I/O port. If it is unused, then it may be left open circuit. If Synchronisation is used, then route the incoming Synchronisation signal as far away from noise sensitive input pins as possible.
- CS pin - This connection is arguably the most important single connection in the entire PSU system. Avoid running the CS signal traces near to sources of high dv/dt. Provide a simple RC filter as close as possible to the pin to help filter out leading edge noise spikes which will occur at the beginning of each switching cycle.
- SS/DISB pin - Keep tracks from this pin as short as possible. If the Enable signal is coming from a remote source then avoid running it close to any source of high dv/dt (MOSFET Drain connections for example) and add a simple RC filter at the SS/DISB pin.
- OUTA, OUTB, OUTC, and OUTD pins - These are the gate drive output pins and will have a high dv/dt rate associated with their rising and falling edges. Keep the tracks from these pins as far away from noise sensitive input pins as possible. Ensure that the return currents from these outputs do not cause voltage changes in the analog ground connections to noise sensitive input pins.
- VDD pin - This pin must be decoupled to PGND using ceramic capacitors as detailed in the [Power Supply Recommendations](#) section. Keep this capacitor as close to the VDD and PGND pins as possible.
- GND pin - This pin provides the analog ground reference to the controller. Use this pin to provide a return path for the components at the RAMP, REF, CT, RT, DELAB, DELCD, ADS, CS, and SS/DISB pins. Use a Ground Plane to minimise the impedance of the ground connection and to reduce noise pickup. It is important to have a low impedance connection from GND to PGND.
- PGND pin - This pin provides the ground reference to the controller. This pin should be used to return the currents from the OUTX and SYNC pins. Use a Ground Plane to minimise the impedance of the ground connection and to reduce noise pickup.

An ideal ground plane provides an equipotential surface to which the controller ground pins can be connected. However, real ground planes have a non-zero impedance and having separate ground planes for analog and driver circuits is an easy way to prevent the analog ground from being disturbed by driver return currents. A single ground plane may be used if care is taken to ensure that the driver return currents are kept away from the part of the ground plane used for analog connections.

10.2 Layout Example

Further layout information for this device is given in application report [SLUA501](#).

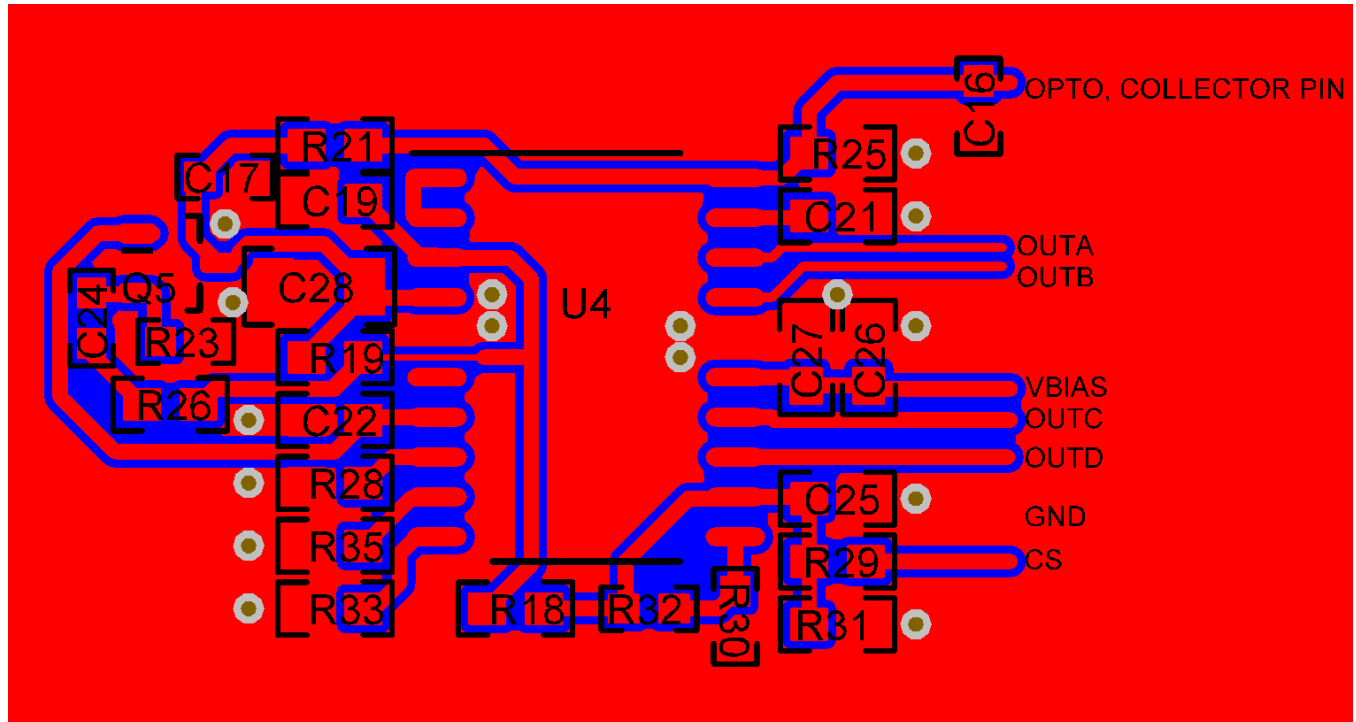

Figure 29. Suggested PCB Layout

11 器件和文档支持

11.1 文档支持

11.1.1 相关文档

请参阅如下相关文档：

1. 《UCC2895 布局和接地建议》，(SLUA501)。
2. 《在直接控制驱动同步整流器应用中 使用 UCC3895》，(SLUU109)。
3. M. Dennis, 《BiCMOS UCC3895 相移控制器与 UC3875 比较》，应用手册 (SLUA246)。
4. L. Balogh, 《倍流整流器：推挽和桥式转换器的替代整流技术》，应用手册 (SLUA121)。
5. W. Andreyck, 《相移、零电压转换设计注意事项》，应用手册 (SLUA107)。
6. L. Balogh, 《全新 UC3879 相移 PWM 控制器简化了零电压转换全桥转换器的设计》，应用手册 (SLUA122)。
7. L. Balogh, 设计评审：《采用倍流同步整流技术的 100W、400kHz 直流/直流转换器可实现 92% 的效率》，Unitrode 电源设计研讨会手册，SEM-1100，1996，主题 2。
8. 《UC3875 相移谐振控制器》，数据表 (SLUS229)。
9. 《UC3879 相移谐振控制器》，数据表 (SLUS230)。
10. UCC3895EVM-1, 《在直接控制驱动同步整流器应用中 使用 UCC3895》，用户指南 (SLUU109)。
11. UCC3895, 《OUTC/OUTD 非对称占空比运行》，应用报告 (SLUA275)。
12. 《倍流整流器可消除纹波电流》，应用手册 (SLUA323)。
13. 《相移全桥转换器中的控制驱动同步整流器》，应用手册 (SLUA287)。

11.1.2 相关链接

下表列出了快速访问链接。类别包括技术文档、支持与社区资源、工具和软件，以及申请样片或购买产品的快速链接。

表 2. 相关链接

器件	产品文件夹	样片与购买	技术文档	工具与软件	支持和社区
UCC1895	单击此处	单击此处	单击此处	单击此处	单击此处
UCC2895	单击此处	单击此处	单击此处	单击此处	单击此处
UCC3895	单击此处	单击此处	单击此处	单击此处	单击此处

11.2 接收文档更新通知

要接收文档更新通知，请导航至 [ti.com](#) 上的器件产品文件夹。单击右上角的通知我进行注册，即可每周接收产品信息更改摘要。有关更改的详细信息，请查阅已修订文档中包含的修订历史记录。

11.3 社区资源

TI E2E™ support forums are an engineer's go-to source for fast, verified answers and design help — straight from the experts. Search existing answers or ask your own question to get the quick design help you need.

Linked content is provided "AS IS" by the respective contributors. They do not constitute TI specifications and do not necessarily reflect TI's views; see TI's [Terms of Use](#).

11.4 商标

E2E is a trademark of Texas Instruments.

United Chemi-Con is a trademark of United Chemi-Con.

All other trademarks are the property of their respective owners.

11.5 静电放电警告



这些装置包含有限的内置 ESD 保护。存储或装卸时，应将导线一起截短或将装置放置于导电泡棉中，以防止 MOS 门极遭受静电损伤。

11.6 Glossary

[SLYZ022](#) — *TI Glossary*.

This glossary lists and explains terms, acronyms, and definitions.

12 机械、封装和可订购信息

以下页面包含机械、封装和可订购信息。这些信息是指定器件的最新可用数据。数据如有变更，恕不另行通知，且不会对此文档进行修订。如需获取此数据表的浏览器版本，请查阅左侧的导航栏。

PACKAGING INFORMATION

Orderable Device	Status (1)	Package Type	Package Drawing	Pins	Package Qty	Eco Plan (2)	Lead finish/ Ball material (6)	MSL Peak Temp (3)	Op Temp (°C)	Device Marking (4/5)	Samples
UCC1895J	ACTIVE	CDIP	J	20	1	Non-RoHS & Green	SNPB	N / A for Pkg Type	-55 to 125	UCC1895J	Samples
UCC1895L	ACTIVE	LCCC	FK	20	1	Non-RoHS & Green	SNPB	N / A for Pkg Type	-55 to 125	UCC1895L	Samples
UCC2895DW	ACTIVE	SOIC	DW	20	25	RoHS & Green	NIPDAU	Level-2-260C-1 YEAR	-40 to 85	UCC2895DW	Samples
UCC2895DWG4	ACTIVE	SOIC	DW	20	25	RoHS & Green	NIPDAU	Level-2-260C-1 YEAR	-40 to 85	UCC2895DW	Samples
UCC2895DWTR	ACTIVE	SOIC	DW	20	2000	RoHS & Green	NIPDAU	Level-2-260C-1 YEAR	-40 to 85	UCC2895DW	Samples
UCC2895DWTRG4	ACTIVE	SOIC	DW	20	2000	RoHS & Green	NIPDAU	Level-2-260C-1 YEAR	-40 to 85	UCC2895DW	Samples
UCC2895N	ACTIVE	PDIP	N	20	18	RoHS & Green	NIPDAU	N / A for Pkg Type	-40 to 85	UCC2895N	Samples
UCC2895PW	ACTIVE	TSSOP	PW	20	70	RoHS & Green	NIPDAU	Level-2-260C-1 YEAR	-40 to 85	UCC2895	Samples
UCC2895PWTR	ACTIVE	TSSOP	PW	20	2000	RoHS & Green	NIPDAU	Level-2-260C-1 YEAR	-40 to 85	UCC2895	Samples
UCC3895DW	ACTIVE	SOIC	DW	20	25	RoHS & Green	NIPDAU	Level-2-260C-1 YEAR	0 to 70	UCC3895DW	Samples
UCC3895DWG4	ACTIVE	SOIC	DW	20	25	RoHS & Green	NIPDAU	Level-2-260C-1 YEAR	0 to 70	UCC3895DW	Samples
UCC3895DWTR	ACTIVE	SOIC	DW	20	2000	RoHS & Green	NIPDAU	Level-2-260C-1 YEAR	0 to 70	UCC3895DW	Samples
UCC3895DWTRG4	ACTIVE	SOIC	DW	20	2000	RoHS & Green	NIPDAU	Level-2-260C-1 YEAR	0 to 70	UCC3895DW	Samples
UCC3895N	ACTIVE	PDIP	N	20	18	RoHS & Green	NIPDAU	N / A for Pkg Type	0 to 70	UCC3895N	Samples
UCC3895NG4	ACTIVE	PDIP	N	20	18	RoHS & Green	NIPDAU	N / A for Pkg Type	0 to 70	UCC3895N	Samples
UCC3895PW	ACTIVE	TSSOP	PW	20	70	RoHS & Green	NIPDAU	Level-2-260C-1 YEAR	0 to 70	UCC3895	Samples
UCC3895PWTR	ACTIVE	TSSOP	PW	20	2000	RoHS & Green	NIPDAU	Level-2-260C-1 YEAR	0 to 70	UCC3895	Samples
UCC3895PWTRG4	ACTIVE	TSSOP	PW	20	2000	RoHS & Green	NIPDAU	Level-2-260C-1 YEAR	0 to 70	UCC3895	Samples

(1) The marketing status values are defined as follows:
ACTIVE: Product device recommended for new designs.

LIFEBUY: TI has announced that the device will be discontinued, and a lifetime-buy period is in effect.

NRND: Not recommended for new designs. Device is in production to support existing customers, but TI does not recommend using this part in a new design.

PREVIEW: Device has been announced but is not in production. Samples may or may not be available.

OBSELETE: TI has discontinued the production of the device.

⁽²⁾ **RoHS:** TI defines "RoHS" to mean semiconductor products that are compliant with the current EU RoHS requirements for all 10 RoHS substances, including the requirement that RoHS substance do not exceed 0.1% by weight in homogeneous materials. Where designed to be soldered at high temperatures, "RoHS" products are suitable for use in specified lead-free processes. TI may reference these types of products as "Pb-Free".

RoHS Exempt: TI defines "RoHS Exempt" to mean products that contain lead but are compliant with EU RoHS pursuant to a specific EU RoHS exemption.

Green: TI defines "Green" to mean the content of Chlorine (Cl) and Bromine (Br) based flame retardants meet JS709B low halogen requirements of <=1000ppm threshold. Antimony trioxide based flame retardants must also meet the <=1000ppm threshold requirement.

⁽³⁾ MSL, Peak Temp. - The Moisture Sensitivity Level rating according to the JEDEC industry standard classifications, and peak solder temperature.

⁽⁴⁾ There may be additional marking, which relates to the logo, the lot trace code information, or the environmental category on the device.

⁽⁵⁾ Multiple Device Markings will be inside parentheses. Only one Device Marking contained in parentheses and separated by a "~" will appear on a device. If a line is indented then it is a continuation of the previous line and the two combined represent the entire Device Marking for that device.

⁽⁶⁾ Lead finish/Ball material - Orderable Devices may have multiple material finish options. Finish options are separated by a vertical ruled line. Lead finish/Ball material values may wrap to two lines if the finish value exceeds the maximum column width.

Important Information and Disclaimer:The information provided on this page represents TI's knowledge and belief as of the date that it is provided. TI bases its knowledge and belief on information provided by third parties, and makes no representation or warranty as to the accuracy of such information. Efforts are underway to better integrate information from third parties. TI has taken and continues to take reasonable steps to provide representative and accurate information but may not have conducted destructive testing or chemical analysis on incoming materials and chemicals. TI and TI suppliers consider certain information to be proprietary, and thus CAS numbers and other limited information may not be available for release.

In no event shall TI's liability arising out of such information exceed the total purchase price of the TI part(s) at issue in this document sold by TI to Customer on an annual basis.

OTHER QUALIFIED VERSIONS OF UCC1895, UCC2895, UCC3895 :

- Catalog : [UCC3895](#)
- Automotive : [UCC2895-Q1](#)
- Enhanced Product : [UCC2895-EP](#)
- Military : [UCC1895](#)

NOTE: Qualified Version Definitions:

- Catalog - TI's standard catalog product
- Automotive - Q100 devices qualified for high-reliability automotive applications targeting zero defects
- Enhanced Product - Supports Defense, Aerospace and Medical Applications
- Military - QML certified for Military and Defense Applications

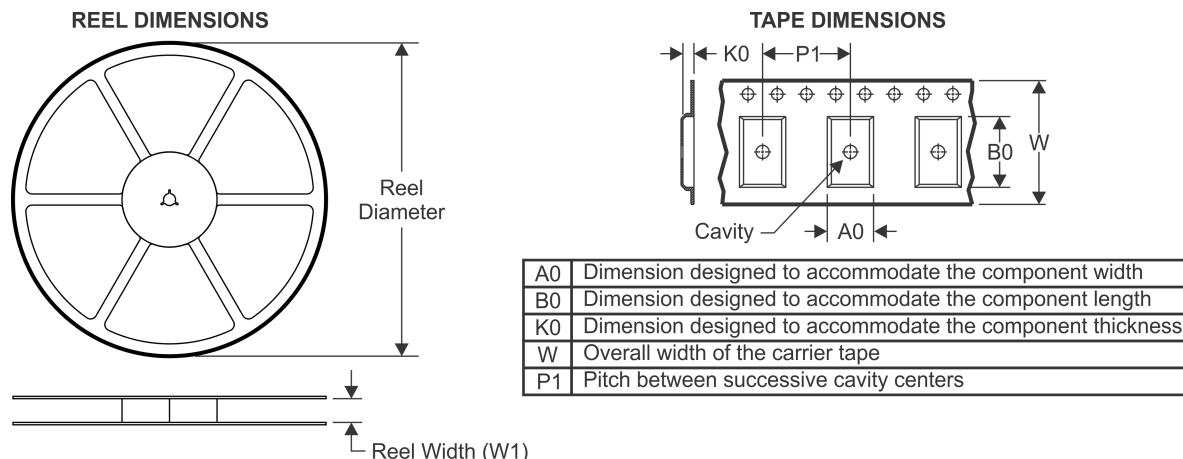
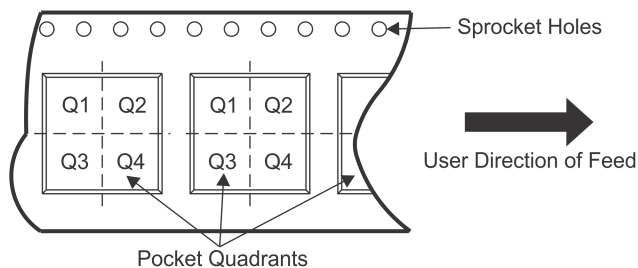
TAPE AND REEL INFORMATION

QUADRANT ASSIGNMENTS FOR PIN 1 ORIENTATION IN TAPE

*All dimensions are nominal

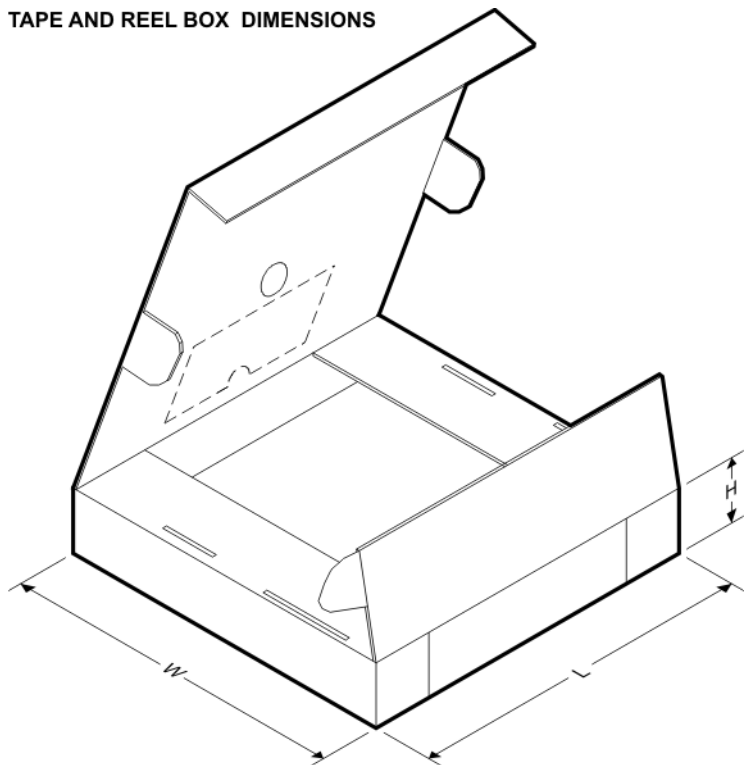
Device	Package Type	Package Drawing	Pins	SPQ	Reel Diameter (mm)	Reel Width W1 (mm)	A0 (mm)	B0 (mm)	K0 (mm)	P1 (mm)	W (mm)	Pin1 Quadrant
UCC2895PWTR	TSSOP	PW	20	2000	330.0	16.4	6.95	7.1	1.6	8.0	16.0	Q1
UCC3895DWTR	SOIC	DW	20	2000	330.0	24.4	10.8	13.3	2.7	12.0	24.0	Q1
UCC3895PWTR	TSSOP	PW	20	2000	330.0	16.4	6.95	7.1	1.6	8.0	16.0	Q1

TAPE AND REEL BOX DIMENSIONS

*All dimensions are nominal

Device	Package Type	Package Drawing	Pins	SPQ	Length (mm)	Width (mm)	Height (mm)
UCC2895PWTR	TSSOP	PW	20	2000	853.0	449.0	35.0
UCC3895DWTR	SOIC	DW	20	2000	350.0	350.0	43.0
UCC3895PWTR	TSSOP	PW	20	2000	367.0	367.0	38.0

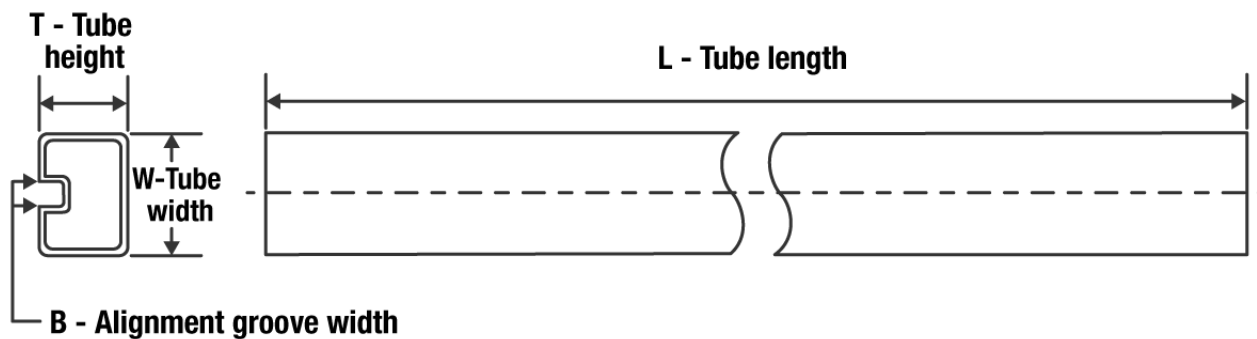
TUBE

*All dimensions are nominal

Device	Package Name	Package Type	Pins	SPQ	L (mm)	W (mm)	T (μm)	B (mm)
UCC1895L	FK	LCCC	20	1	506.98	12.06	2030	NA
UCC2895DW	DW	SOIC	20	25	507	12.83	5080	6.6
UCC2895DWG4	DW	SOIC	20	25	507	12.83	5080	6.6
UCC2895N	N	PDIP	20	18	506	13.97	11230	4.32
UCC2895PW	PW	TSSOP	20	70	530	10.2	3600	3.5
UCC3895DW	DW	SOIC	20	25	507	12.83	5080	6.6
UCC3895DWG4	DW	SOIC	20	25	507	12.83	5080	6.6
UCC3895N	N	PDIP	20	18	506	13.97	11230	4.32
UCC3895NG4	N	PDIP	20	18	506	13.97	11230	4.32
UCC3895PW	PW	TSSOP	20	70	530	10.2	3600	3.5

PW0020A

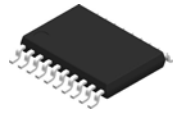

PACKAGE OUTLINE

TSSOP - 1.2 mm max height

SMALL OUTLINE PACKAGE

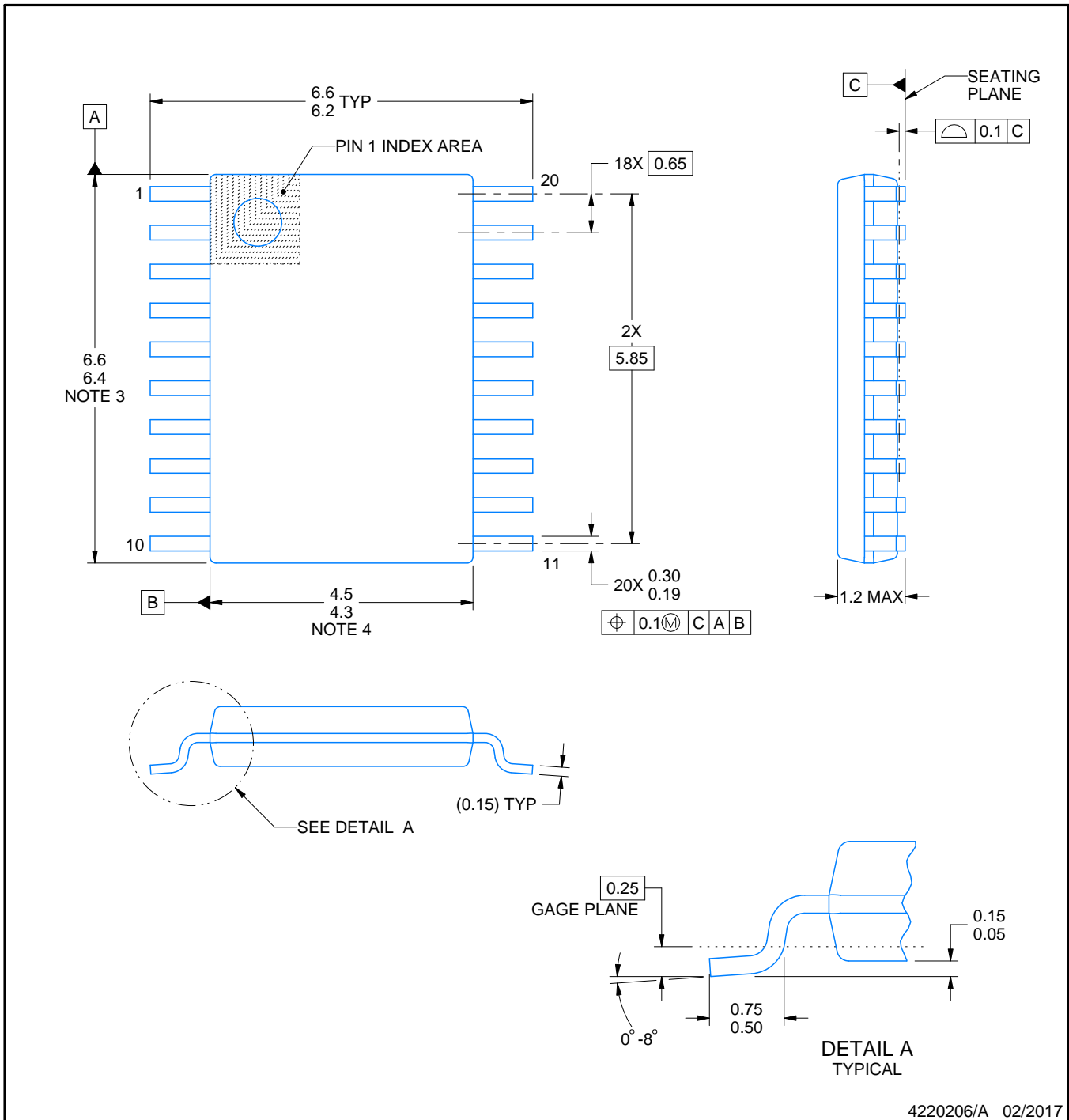

4220206/A 02/2017

NOTES:

- All linear dimensions are in millimeters. Any dimensions in parenthesis are for reference only. Dimensioning and tolerancing per ASME Y14.5M.
- This drawing is subject to change without notice.
- This dimension does not include mold flash, protrusions, or gate burrs. Mold flash, protrusions, or gate burrs shall not exceed 0.15 mm per side.
- This dimension does not include interlead flash. Interlead flash shall not exceed 0.25 mm per side.
- Reference JEDEC registration MO-153.

EXAMPLE BOARD LAYOUT

PW0020A

TSSOP - 1.2 mm max height

SMALL OUTLINE PACKAGE

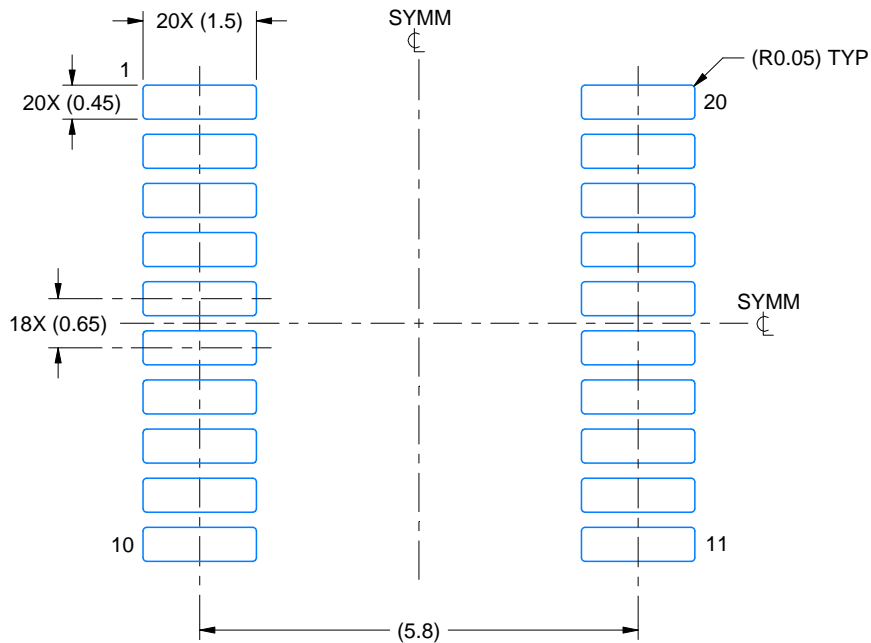

LAND PATTERN EXAMPLE
EXPOSED METAL SHOWN
SCALE: 10X

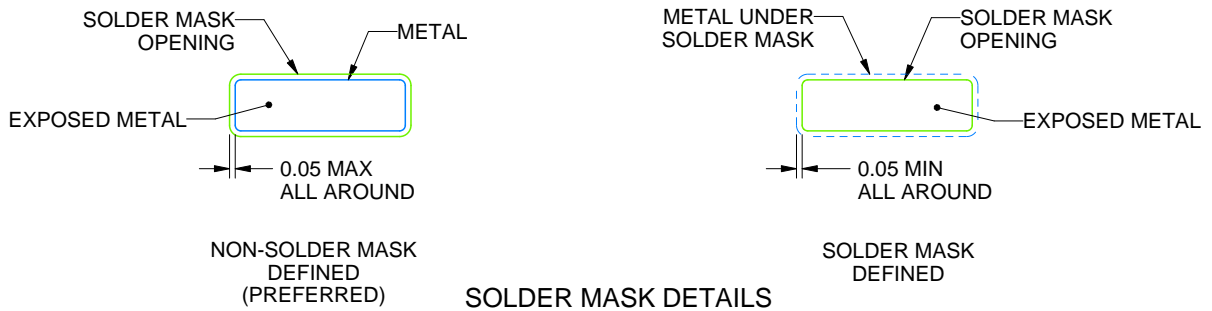

SOLDER MASK DETAILS

4220206/A 02/2017

NOTES: (continued)

- 6. Publication IPC-7351 may have alternate designs.
- 7. Solder mask tolerances between and around signal pads can vary based on board fabrication site.

EXAMPLE STENCIL DESIGN

PW0020A

TSSOP - 1.2 mm max height

SMALL OUTLINE PACKAGE

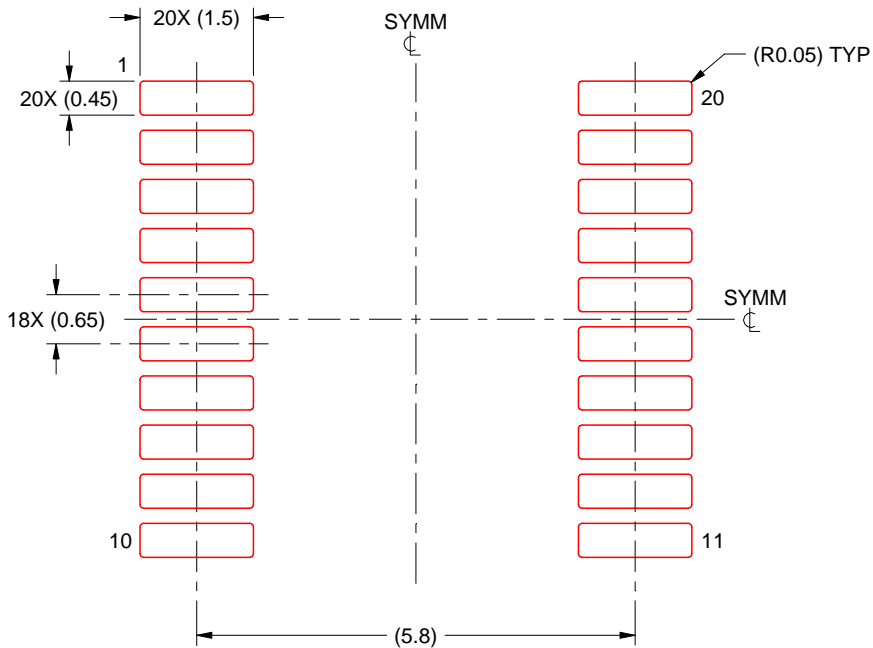

SOLDER PASTE EXAMPLE
BASED ON 0.125 mm THICK STENCIL
SCALE: 10X

4220206/A 02/2017

NOTES: (continued)

8. Laser cutting apertures with trapezoidal walls and rounded corners may offer better paste release. IPC-7525 may have alternate design recommendations.
9. Board assembly site may have different recommendations for stencil design.

PW (R-PDSO-G20)

PLASTIC SMALL OUTLINE

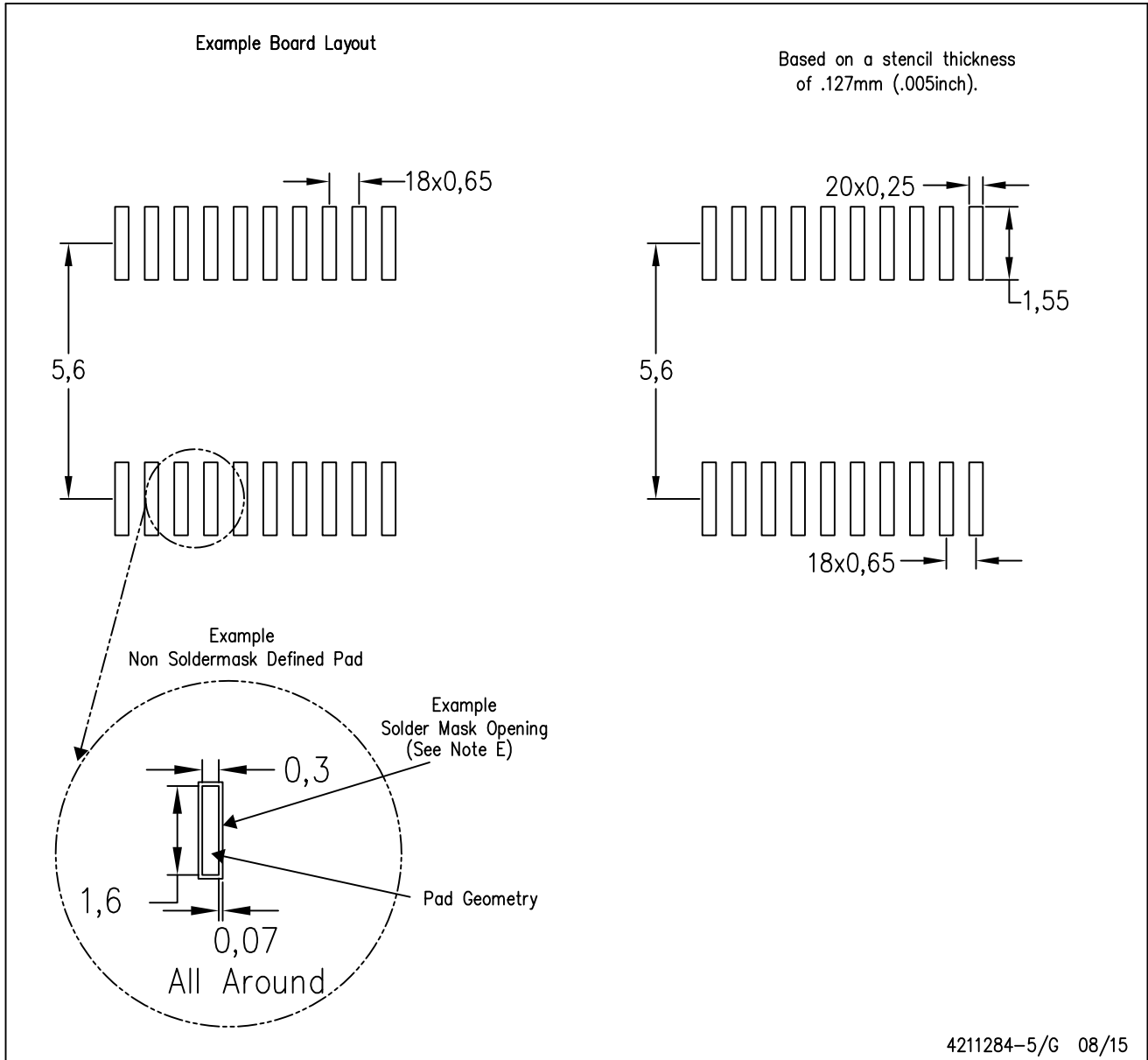

- NOTES:
- A. All linear dimensions are in millimeters.
 - B. This drawing is subject to change without notice.
 - C. Publication IPC-7351 is recommended for alternate design.
 - D. Laser cutting apertures with trapezoidal walls and also rounding corners will offer better paste release. Customers should contact their board assembly site for stencil design recommendations. Refer to IPC-7525 for other stencil recommendations.
 - E. Customers should contact their board fabrication site for solder mask tolerances between and around signal pads.

FK (S-CQCC-N**)

LEADLESS CERAMIC CHIP CARRIER

28 TERMINAL SHOWN

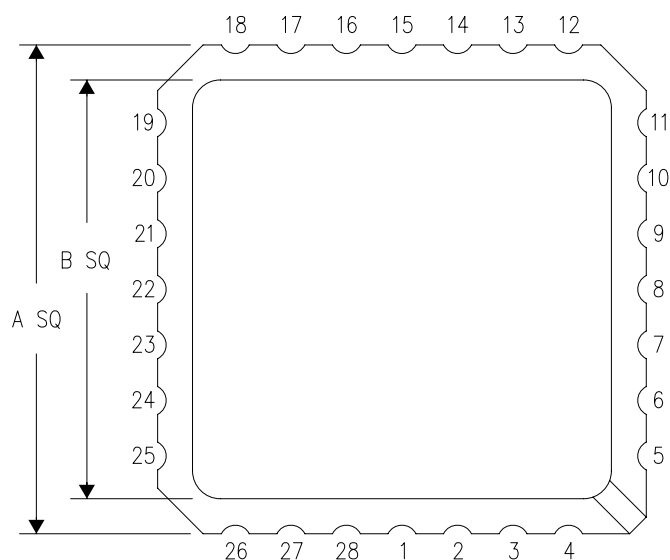

NO. OF TERMINALS **	A		B	
	MIN	MAX	MIN	MAX
20	0.342 (8,69)	0.358 (9,09)	0.307 (7,80)	0.358 (9,09)
28	0.442 (11,23)	0.458 (11,63)	0.406 (10,31)	0.458 (11,63)
44	0.640 (16,26)	0.660 (16,76)	0.495 (12,58)	0.560 (14,22)
52	0.740 (18,78)	0.761 (19,32)	0.495 (12,58)	0.560 (14,22)
68	0.938 (23,83)	0.962 (24,43)	0.850 (21,6)	0.858 (21,8)
84	1.141 (28,99)	1.165 (29,59)	1.047 (26,6)	1.063 (27,0)

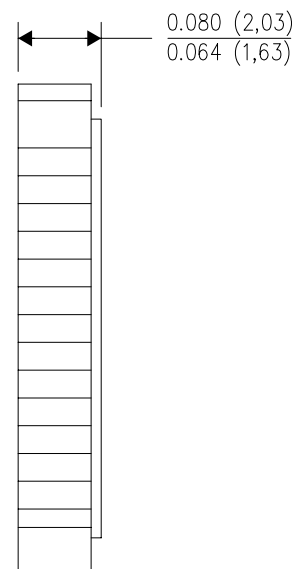
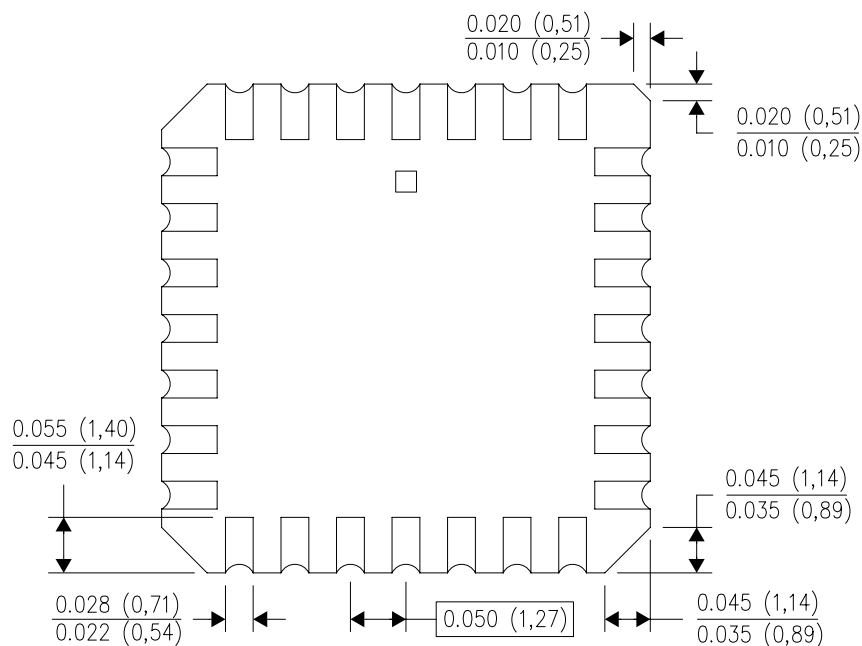

4040140/D 01/11

- NOTES:
- All linear dimensions are in inches (millimeters).
 - This drawing is subject to change without notice.
 - This package can be hermetically sealed with a metal lid.
 - Falls within JEDEC MS-004

J (R-GDIP-T**)

14 LEADS SHOWN

CERAMIC DUAL IN-LINE PACKAGE

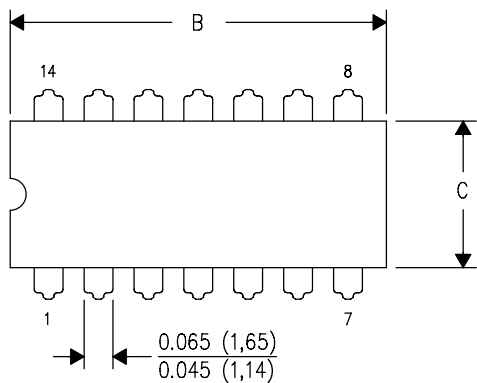

DIM \ PINS **	14	16	18	20
A	0.300 (7,62) BSC	0.300 (7,62) BSC	0.300 (7,62) BSC	0.300 (7,62) BSC
B MAX	0.785 (19,94)	.840 (21,34)	0.960 (24,38)	1.060 (26,92)
B MIN	—	—	—	—
C MAX	0.300 (7,62)	0.300 (7,62)	0.310 (7,87)	0.300 (7,62)
C MIN	0.245 (6,22)	0.245 (6,22)	0.220 (5,59)	0.245 (6,22)

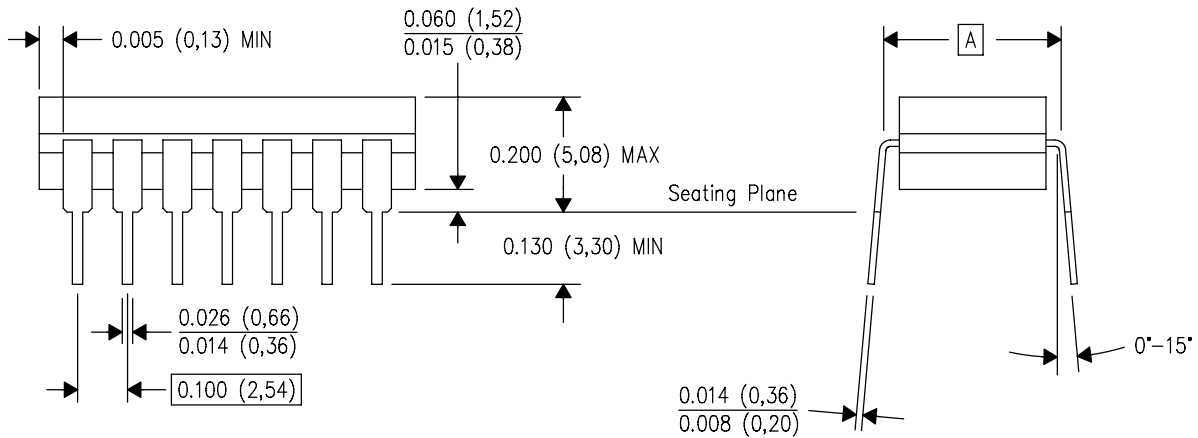

4040083/F 03/03

- NOTES:
- All linear dimensions are in inches (millimeters).
 - This drawing is subject to change without notice.
 - This package is hermetically sealed with a ceramic lid using glass frit.
 - Index point is provided on cap for terminal identification only on press ceramic glass frit seal only.
 - Falls within MIL STD 1835 GDIP1-T14, GDIP1-T16, GDIP1-T18 and GDIP1-T20.

N (R-PDIP-T**)

PLASTIC DUAL-IN-LINE PACKAGE

16 PINS SHOWN



- NOTES:
- A. All linear dimensions are in inches (millimeters).
 - B. This drawing is subject to change without notice.
 - Falls within JEDEC MS-001, except 18 and 20 pin minimum body length (Dim A).
 - The 20 pin end lead shoulder width is a vendor option, either half or full width.

DW0020A

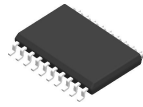

PACKAGE OUTLINE

SOIC - 2.65 mm max height

SOIC

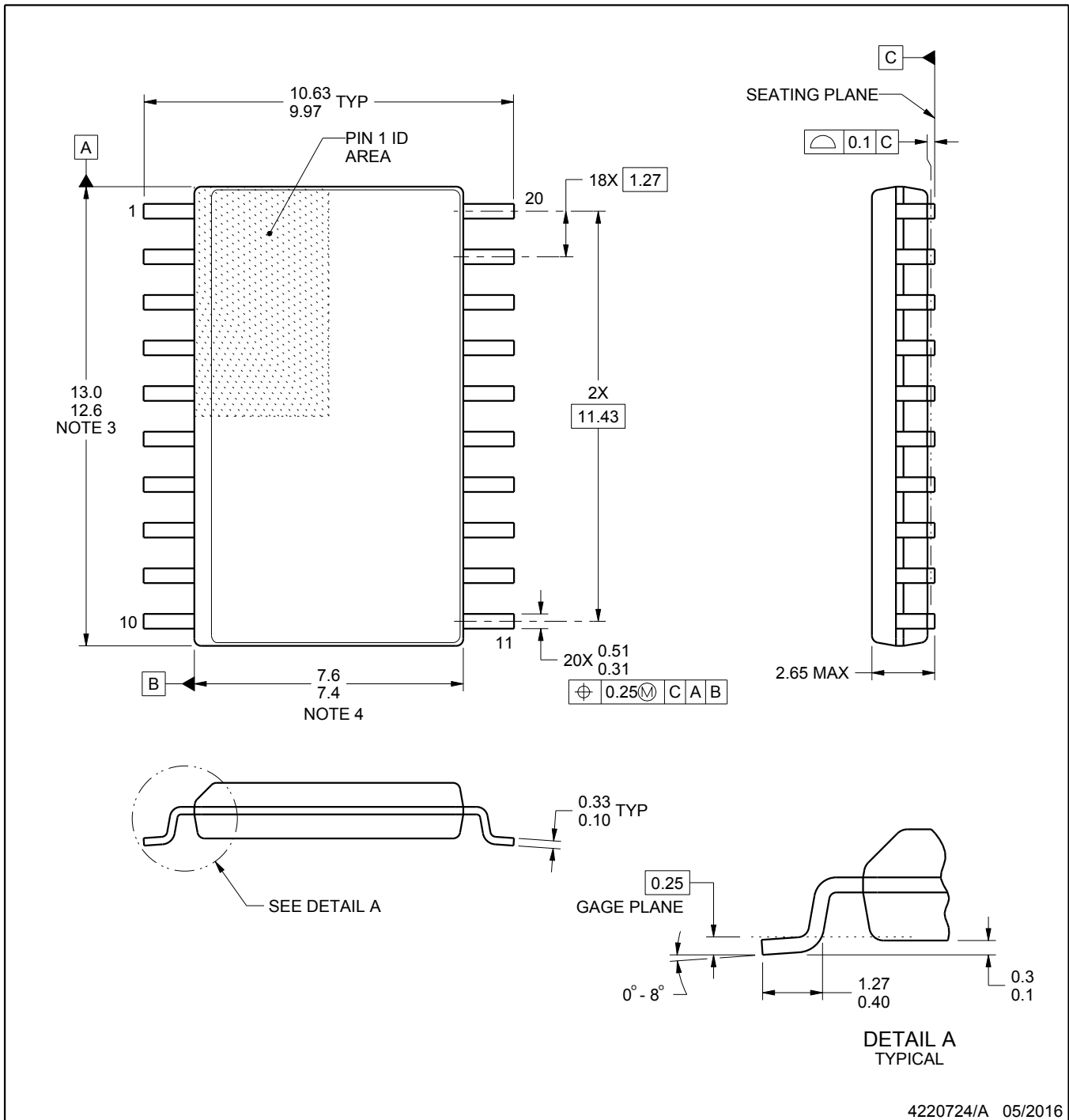

4220724/A 05/2016

NOTES:

1. All linear dimensions are in millimeters. Dimensions in parenthesis are for reference only. Dimensioning and tolerancing per ASME Y14.5M.
2. This drawing is subject to change without notice.
3. This dimension does not include mold flash, protrusions, or gate burrs. Mold flash, protrusions, or gate burrs shall not exceed 0.15 mm per side.
4. This dimension does not include interlead flash. Interlead flash shall not exceed 0.43 mm per side.
5. Reference JEDEC registration MS-013.

EXAMPLE BOARD LAYOUT

DW0020A

SOIC - 2.65 mm max height

SOIC

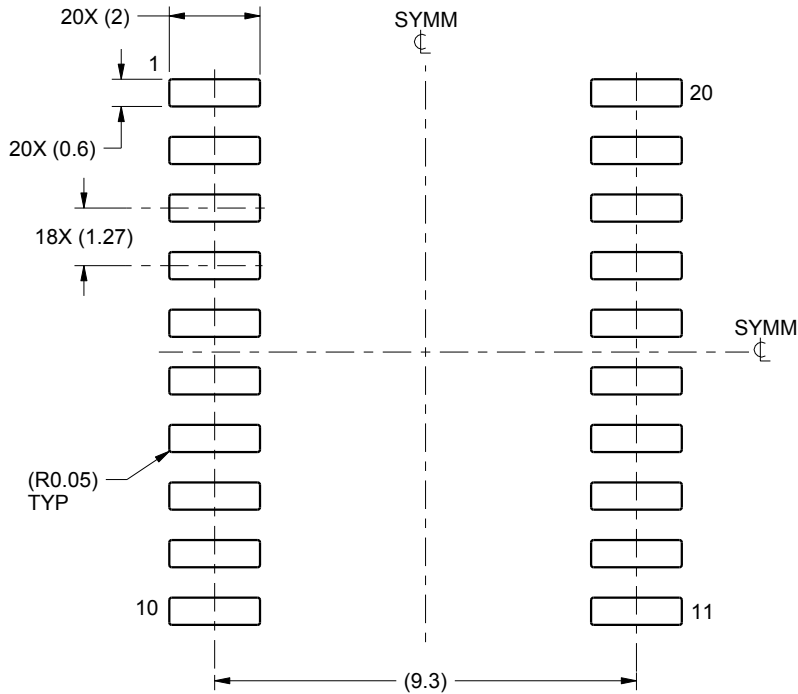

LAND PATTERN EXAMPLE
SCALE:6X

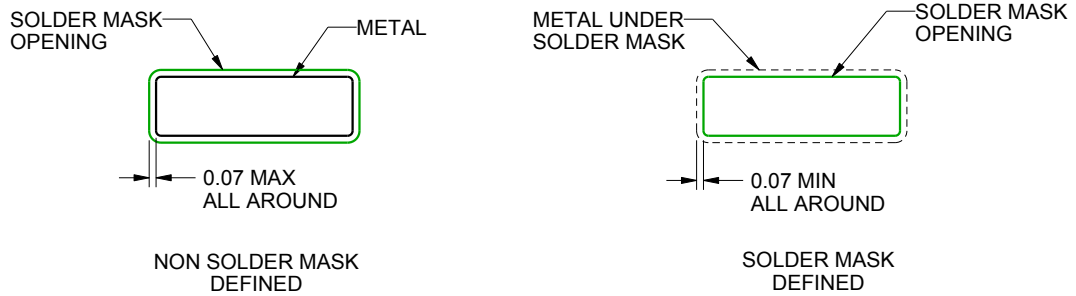

SOLDER MASK DETAILS

4220724/A 05/2016

NOTES: (continued)

- 6. Publication IPC-7351 may have alternate designs.
- 7. Solder mask tolerances between and around signal pads can vary based on board fabrication site.

EXAMPLE STENCIL DESIGN

DW0020A

SOIC - 2.65 mm max height

SOIC

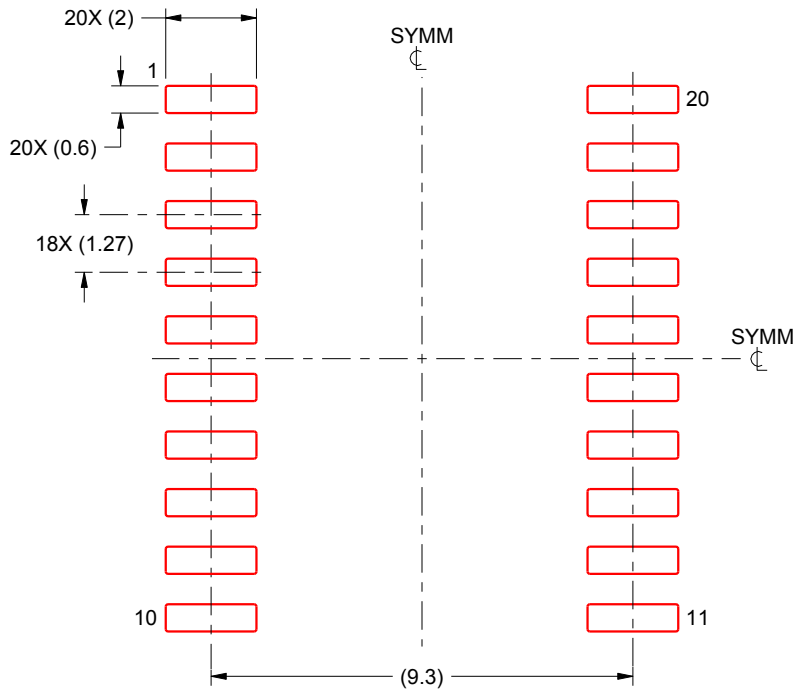

SOLDER PASTE EXAMPLE
BASED ON 0.125 mm THICK STENCIL
SCALE:6X

4220724/A 05/2016

NOTES: (continued)

8. Laser cutting apertures with trapezoidal walls and rounded corners may offer better paste release. IPC-7525 may have alternate design recommendations.
9. Board assembly site may have different recommendations for stencil design.

重要声明和免责声明

TI“按原样”提供技术和可靠性数据（包括数据表）、设计资源（包括参考设计）、应用或其他设计建议、网络工具、安全信息和其他资源，不保证没有瑕疵且不做任何明示或暗示的担保，包括但不限于对适销性、某特定用途方面的适用性或不侵犯任何第三方知识产权的暗示担保。

这些资源可供使用 TI 产品进行设计的熟练开发人员使用。您将自行承担以下全部责任：(1) 针对您的应用选择合适的 TI 产品，(2) 设计、验证并测试您的应用，(3) 确保您的应用满足相应标准以及任何其他功能安全、信息安全、监管或其他要求。

这些资源如有变更，恕不另行通知。TI 授权您仅可将这些资源用于研发本资源所述的 TI 产品的应用。严禁对这些资源进行其他复制或展示。您无权使用任何其他 TI 知识产权或任何第三方知识产权。您应全额赔偿因在这些资源的使用中对 TI 及其代表造成的任何索赔、损害、成本、损失和债务，TI 对此概不负责。

TI 提供的产品受 [TI 的销售条款](#) 或 [ti.com](#) 上其他适用条款/TI 产品随附的其他适用条款的约束。TI 提供这些资源并不会扩展或以其他方式更改 TI 针对 TI 产品发布的适用的担保或担保免责声明。

TI 反对并拒绝您可能提出的任何其他或不同的条款。

邮寄地址：Texas Instruments, Post Office Box 655303, Dallas, Texas 75265

Copyright © 2022，德州仪器 (TI) 公司