

## LM61 2.7-V, SOT-23 or TO-92 Temperature Sensor

### 1 Features

- Calibrated Linear Scale Factor of 10 mV/°C
- Rated for Full Temperature Range (–30° to 100°C)
- Suitable for Remote Applications
- UL Recognized Component
- ±2°C or ±3°C Accuracy at 25°C (Maximum)
- ±3°C Accuracy for –25°C to 85°C (Maximum)
- ±4°C Accuracy for –30°C to 100°C (Maximum)
- 10 mV/°C Temperature Slope (Maximum)
- 2.7-V to 10-V Power Supply Voltage Range
- 125-µA Current Drain at 25°C (Maximum)
- ±0.8°C Nonlinearity (Maximum)
- 800-Ω Output Impedance (Maximum)

### 2 Applications

- Cellular Phones
- Computers
- Power Supply Modules
- Battery Management
- FAX Machines
- Printers
- HVAC
- Disk Drives
- Appliances

### 3 Description

The LM61 device is a precision, integrated-circuit temperature sensor that can sense a –30°C to 100°C temperature range while operating from a single 2.7-V supply. The output voltage of the LM61 is linearly proportional to temperature (10 mV/°C) and has a DC offset of 600 mV. The offset allows reading negative temperatures without the need for a negative supply. The nominal output voltage of the LM61 ranges from 300 mV to 1600 mV for a –30°C to 100°C temperature range. The LM61 is calibrated to provide accuracies of ±2°C at room temperature and ±3°C over the full –25°C to 85°C temperature range.

The linear output of the LM61, 600-mV offset, and factory calibration simplify external circuitry required in a single supply environment where reading negative temperatures is required. Because the quiescent current is less than 125 µA, self-heating is limited to a very low 0.2°C in still air. Shutdown capability for the LM61 is intrinsic because its inherent low power consumption allows it to be powered directly from the output of many logic gates.

#### Device Information<sup>(1)</sup>

PART NUMBER	PACKAGE	BODY SIZE (NOM)
LM61	SOT-23 (3)	1.30 mm × 2.92 mm
	TO-92 (3)	4.30 mm × 4.30 mm

(1) For all available packages, see the orderable addendum at the end of the data sheet.

#### Key Specifications

	VALUE
Accuracy at 25°C	±2°C or ±3°C
Accuracy for –25°C to 85°C	±3°C
Accuracy for –30°C to 100°C	±4°C
Temperature slope	10 mV/°C
Power supply voltage	2.7 V to 10 V
Current drain at 25°C	125 µA
Nonlinearity	±0.8°C
Output impedance	800 Ω

#### Typical Application

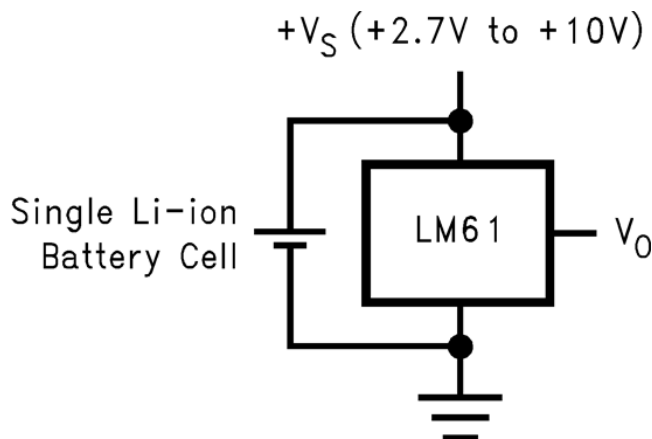

Copyright © 2016, Texas Instruments Incorporated

$$V_O = (10 \text{ mV/}^\circ\text{C} \times T^\circ\text{C}) + 600 \text{ mV}$$



## Table of Contents

<b>1 Features</b> .....	<b>1</b>	<b>8 Application and Implementation</b> .....	<b>8</b>
<b>2 Applications</b> .....	<b>1</b>	8.1 Application Information.....	8
<b>3 Description</b> .....	<b>1</b>	8.2 Typical Applications .....	8
<b>4 Revision History</b> .....	<b>2</b>	<b>9 Power Supply Recommendations</b> .....	<b>11</b>
<b>5 Pin Configuration and Functions</b> .....	<b>3</b>	<b>10 Layout</b> .....	<b>11</b>
<b>6 Specifications</b> .....	<b>3</b>	10.1 Layout Guidelines .....	11
6.1 Absolute Maximum Ratings .....	3	10.2 Layout Examples.....	11
6.2 ESD Ratings.....	3	10.3 Thermal Considerations .....	12
6.3 Recommended Operating Conditions.....	3	<b>11 Device and Documentation Support</b> .....	<b>14</b>
6.4 Thermal Information .....	4	11.1 Related Documentation.....	14
6.5 Electrical Characteristics.....	4	11.2 Receiving Notification of Documentation Updates	14
6.6 Typical Characteristics.....	5	11.3 Community Resources.....	14
<b>7 Detailed Description</b> .....	<b>7</b>	11.4 Trademarks .....	14
7.1 Overview .....	7	11.5 Electrostatic Discharge Caution.....	14
7.2 Functional Block Diagram .....	7	11.6 Glossary .....	14
7.3 Feature Description.....	7	<b>12 Mechanical, Packaging, and Orderable</b>	<b>14</b>
7.4 Device Functional Modes.....	7	<b>Information</b> .....	<b>14</b>

## 4 Revision History

NOTE: Page numbers for previous revisions may differ from page numbers in the current version.

<b>Changes from Revision I (February 2013) to Revision J</b>	<b>Page</b>
• Added <i>Device Information</i> table, <i>Device Comparison Table</i> , <i>Pin Configuration and Functions</i> section, <i>Specifications</i> section, <i>ESD Ratings</i> table, <i>Detailed Description</i> section, <i>Application and Implementation</i> section, <i>Power Supply Recommendations</i> section, <i>Layout</i> section, <i>Device and Documentation Support</i> section, and <i>Mechanical, Packaging, and Orderable Information</i> section .....	1
• Added <i>Thermal Information</i> table .....	4
• Changed R <sub>θJA</sub> values for DBZ (SOT-23) From: 450°C/W To: 286.3°C/W and for LP (TO-92) From: 180°C/W To: 162.2°C/W .....	4

<b>Changes from Revision H (February 2013) to Revision I</b>	<b>Page</b>
• Changed layout of National Semiconductor Data Sheet to TI format .....	1

## 5 Pin Configuration and Functions



### Pin Functions

PIN		TYPE	DESCRIPTION
NAME	NO.		
+VS	1	Power	Positive power supply pin.
VOUT	2	Output	Temperature sensor analog output.
GND	3	Ground	Device ground pin, connected to power supply negative terminal.

## 6 Specifications

### 6.1 Absolute Maximum Ratings

over operating free-air temperature range (unless otherwise noted)<sup>(1)</sup>

	MIN	MAX	UNIT
Supply voltage	12	–0.2	V
Output voltage	(+V <sub>S</sub> + 0.6)	–0.6	V
Output current		10	mA
Input current at any pin <sup>(2)</sup>		5	mA
Maximum junction temperature, T <sub>J</sub>		125	°C
Storage temperature, T <sub>stg</sub>	–65	150	°C

- (1) Stresses beyond those listed under *Absolute Maximum Ratings* may cause permanent damage to the device. These are stress ratings only, which do not imply functional operation of the device at these or any other conditions beyond those indicated under *Recommended Operating Conditions*. Exposure to absolute-maximum-rated conditions for extended periods may affect device reliability.
- (2) When the input voltage (V<sub>I</sub>) at any pin exceeds power supplies (V<sub>I</sub> < GND or V<sub>I</sub> > V<sub>S</sub>), the current at that pin must be limited to 5 mA.

### 6.2 ESD Ratings

		VALUE	UNIT
V <sub>(ESD)</sub>	Electrostatic discharge	Human-body model (HBM), per ANSI/ESDA/JEDEC JS-001 <sup>(1)(2)</sup>	±2500
		Machine Model (MM) <sup>(3)</sup>	±250

- (1) JEDEC document JEP155 states that 500-V HBM allows safe manufacturing with a standard ESD control process.
- (2) The human body model is a 100-pF capacitor discharged through a 1.5-kΩ resistor into each pin.
- (3) The machine model is a 200-pF capacitor discharged directly into each pin.

### 6.3 Recommended Operating Conditions

		MIN	MAX	UNIT
+V <sub>S</sub>	Supply voltage	2	10	V
T	Operating temperature	LM61C	–30	100
		LM61B	–25	85

## 6.4 Thermal Information

THERMAL METRIC <sup>(1)</sup>		LM61		UNIT
		DBZ (SOT-23)	LP (TO-92)	
		3 PINS	3 PINS	
R <sub>θJA</sub>	Junction-to-ambient thermal resistance <sup>(2)</sup>	286.3	162.2	°C/W
R <sub>θJC(top)</sub>	Junction-to-case (top) thermal resistance	96	85	°C/W
R <sub>θJB</sub>	Junction-to-board thermal resistance	57.1	—	°C/W
ψ <sub>JT</sub>	Junction-to-top characterization parameter	5.3	29.2	°C/W
ψ <sub>JB</sub>	Junction-to-board characterization parameter	55.8	141.4	°C/W

(1) For more information about traditional and new thermal metrics, see the [Semiconductor and IC Package Thermal Metrics](#) application report.

(2) The junction-to-ambient thermal resistance is specified without a heat sink in still air.

## 6.5 Electrical Characteristics

+V<sub>S</sub> = 3 V (DC)<sup>(1)(2)</sup>

PARAMETER	TEST CONDITIONS		MIN <sup>(3)</sup>	TYP <sup>(4)</sup>	MAX <sup>(3)</sup>	UNIT
Accuracy <sup>(5)</sup>	T <sub>A</sub> = 25°C	LM61B	–2		2	°C
		LM61C	–3		3	
	LM61B		–3		3	
	LM61C		–4		4	
Output voltage at 0°C				600		mV
Nonlinearity <sup>(6)</sup>	LM61B		–0.6		0.6	°C
	LM61C		–0.8		0.8	
Sensor gain (average slope)	LM61B		9.7	10	10.3	mV/°C
	LM61C		9.6	10	10.4	
Output impedance	+V <sub>S</sub> = 3 V to 10 V				0.8	kΩ
	T <sub>A</sub> = –30°C to 85°C, +V <sub>S</sub> = 2.7 V				2.3	
	T <sub>A</sub> = 85°C to 100°C, +V <sub>S</sub> = 2.7 V				5	
Line regulation <sup>(7)</sup>	+V <sub>S</sub> = 3 V to 10 V		–0.7		0.7	mV/V
	+V <sub>S</sub> = 2.7 V to 3.3 V		–5.7		5.7	mV
Quiescent current	+V <sub>S</sub> = 2.7 V to 10 V	T <sub>A</sub> = 25°C		82	125	μA
					155	
Change of quiescent current	+V <sub>S</sub> = 2.7 V to 10 V			±5		μA
Temperature coefficient of quiescent current				0.2		μA/°C
Long term stability <sup>(8)</sup>	T <sub>J</sub> = T <sub>MAX</sub> = 100°C, for 1000 hours			±0.2		°C

(1) Limits are specified to TI's AOQL (Average Outgoing Quality Level).

(2) Typical limits represent most likely parametric norm.

(3) Maximum and minimum limits apply for T<sub>A</sub> = T<sub>J</sub> = T<sub>MIN</sub> to T<sub>MAX</sub>.

(4) Typical limits apply for T<sub>A</sub> = T<sub>J</sub> = 25°C.

(5) Accuracy is defined as the error between the output voltage and 10 mV/°C multiplied by the device's case temperature plus 600 mV, at specified conditions of voltage, current, and temperature (expressed in °C).

(6) Nonlinearity is defined as the deviation of the output-voltage-versus-temperature curve from the best-fit straight line, over the device's rated temperature range.

(7) Regulation is measured at constant junction temperature, using pulse testing with a low duty cycle. Changes in output due to heating effects can be computed by multiplying the internal dissipation by the thermal resistance.

(8) For best long-term stability, any precision circuit gives best results if the unit is aged at a warm temperature, or temperature cycled for at least 46 hours before long-term life test begins. This is especially true when a small (Surface-Mount) part is wave-soldered; allow time for stress relaxation to occur. The majority of the drift occurs in the first 1000 hours at elevated temperatures. The drift after 1000 hours does not continue at the first 1000-hour rate.

## 6.6 Typical Characteristics

The LM61 in the SOT-23 package mounted to a printed-circuit board as shown in Figure 18 was used to generate the following thermal curves.

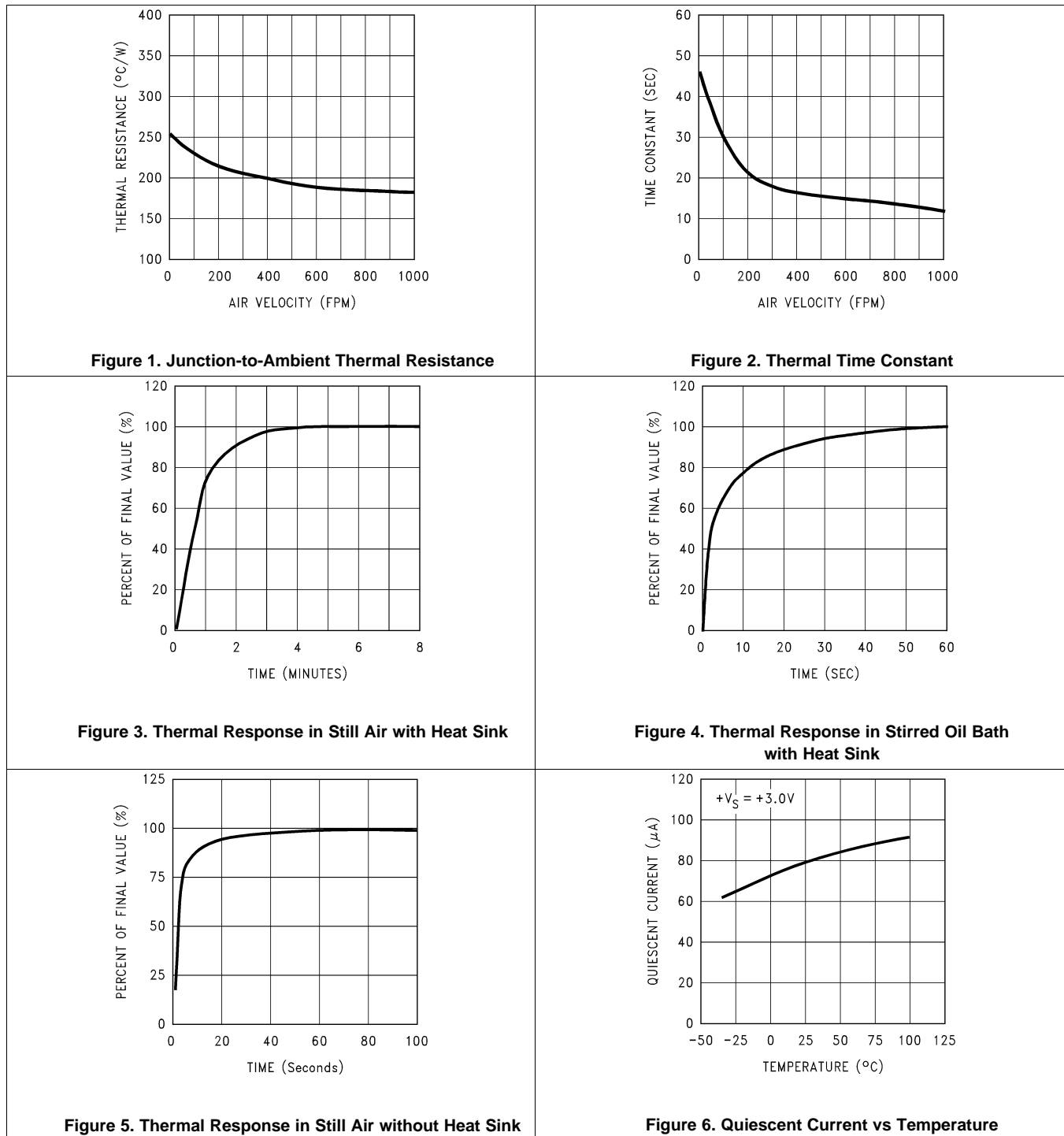

**Typical Characteristics (continued)**

The LM61 in the SOT-23 package mounted to a printed-circuit board as shown in Figure 18 was used to generate the following thermal curves.

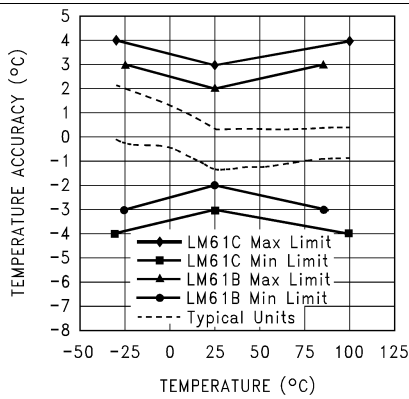

**Figure 7. Accuracy vs Temperature**

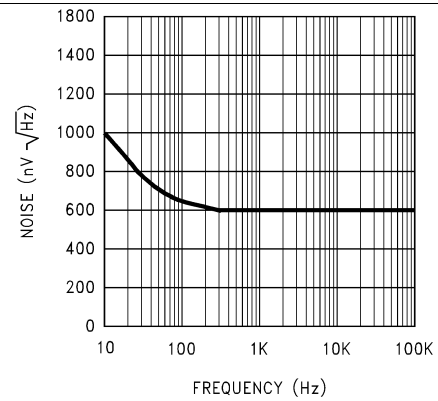

**Figure 8. Noise Voltage**

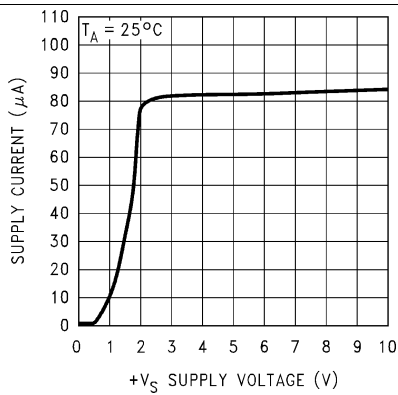

**Figure 9. Supply Voltage vs Supply Current**

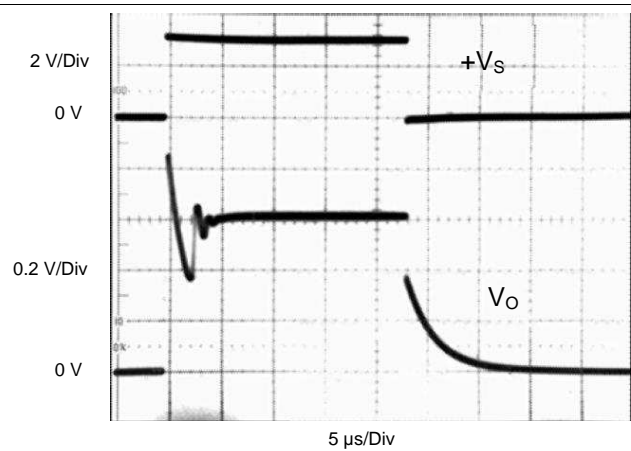

**Figure 10. Start-Up Response**

## 7 Detailed Description

### 7.1 Overview

The LM61 is a precision integrated-circuit temperature sensor that can sense a  $-30^{\circ}\text{C}$  to  $100^{\circ}\text{C}$  temperature range using a single positive supply. The output voltage of the LM61 has a positive temperature slope of  $10\text{ mV}/^{\circ}\text{C}$ . A  $600\text{-mV}$  offset is included, enabling negative temperature sensing when biased by a single supply. The temperature-sensing element is comprised of a delta-VBE architecture. The temperature-sensing element is then buffered by an amplifier and provided to the VOUT pin. The amplifier has a simple class A output stage as shown in [Functional Block Diagram](#).

### 7.2 Functional Block Diagram

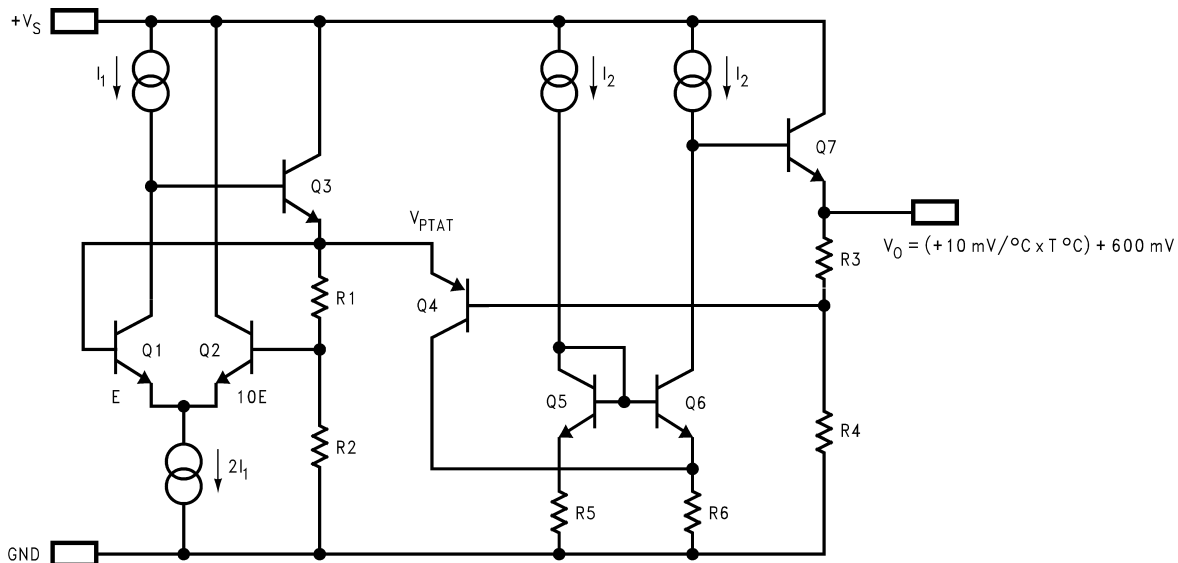

### 7.3 Feature Description

#### 7.3.1 LM61 Transfer Function

The LM61 follows a simple linear transfer function to achieve the accuracy as listed in [Electrical Characteristics](#). Use [Equation 1](#) to calculate the value of  $V_O$ .

$$V_O = 10\text{ mV}/^{\circ}\text{C} \times T^{\circ}\text{C} + 600\text{ mV}$$

where

- $T$  is the temperature in  $^{\circ}\text{C}$
- $V_O$  is the LM61 output voltage

(1)

### 7.4 Device Functional Modes

The only functional mode of the LM61 device is an analog output directly proportional to temperature.

## 8 Application and Implementation

### NOTE

Information in the following applications sections is not part of the TI component specification, and TI does not warrant its accuracy or completeness. TI's customers are responsible for determining suitability of components for their purposes. Customers should validate and test their design implementation to confirm system functionality.

### 8.1 Application Information

The LM61 has a wide supply range and a 10-mV/°C output slope with a 600-mV DC. Therefore, it can be easily applied in many temperature-sensing applications where a single supply is required for positive and negative temperatures.

### 8.2 Typical Applications

#### 8.2.1 Typical Temperature Sensing Circuit

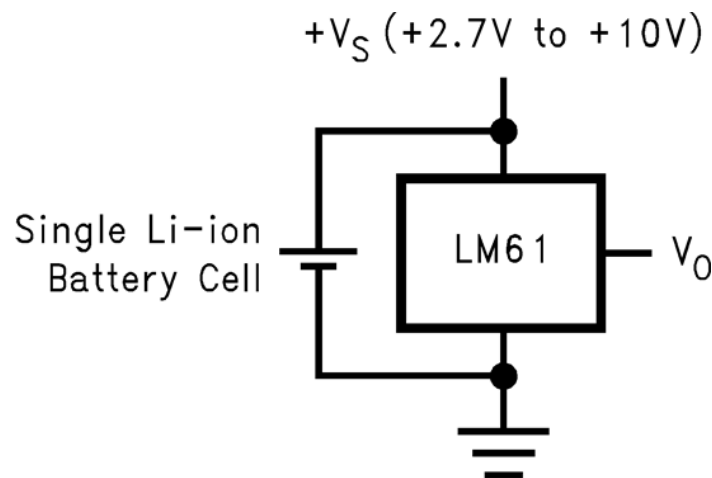

Copyright © 2016, Texas Instruments Incorporated

$$V_O = 10 \text{ mV/}^\circ\text{C} \times T^\circ\text{C} + 600 \text{ mV}$$

**Figure 11. Typical Temperature Sensing Circuit Diagram**

#### 8.2.1.1 Design Requirements

For this design example, use the parameters listed in [Table 1](#) as the input parameters.

**Table 1. Design Parameters**

PARAMETER	VALUE
Power supply voltage	2.7 V to 3.3 V
Accuracy at 25°C	±2°C (maximum)
Accuracy over –25°C to 85°C	±3°C (maximum)
Temperature slope	10 mV/°C

### 8.2.1.2 Detailed Design Procedure

The LM61 is a simple temperature sensor that provides an analog output. Therefore, design requirements related to layout outweigh other requirements in importance. See [Layout](#) for more information.

#### 8.2.1.2.1 Capacitive Loads

The LM61 handles capacitive loading well. Without any special precautions, the LM61 can drive any capacitive load as shown in [Figure 12](#). Over the specified temperature range the LM61 has a maximum output impedance of 5 k $\Omega$ . In an extremely noisy environment it may be necessary to add some filtering to minimize noise pickup. It is recommended that 0.1- $\mu$ F capacitor be added between +VS and GND to bypass the power-supply voltage, as shown in [Figure 13](#). In a noisy environment it may be necessary to add a capacitor from VOUT to ground. A 1- $\mu$ F output capacitor with the 5-k $\Omega$  maximum output impedance forms a 32-Hz lowpass filter. Because the thermal time constant of the LM61 is much slower than the 5-ms time constant formed by the RC, the overall response time of the LM61 is not significantly affected. For much larger capacitors this additional time lag increases the overall response time of the LM61.

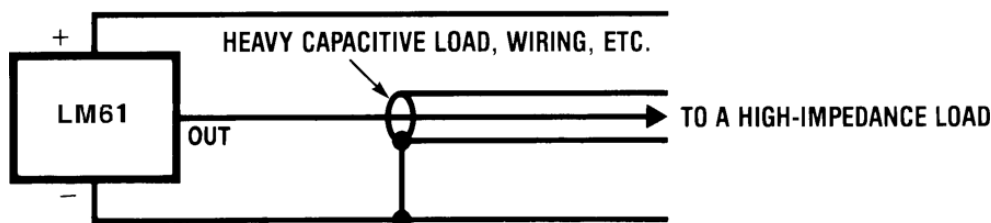

Copyright © 2016, Texas Instruments Incorporated

Figure 12. LM61 No Decoupling Required for Capacitive Load

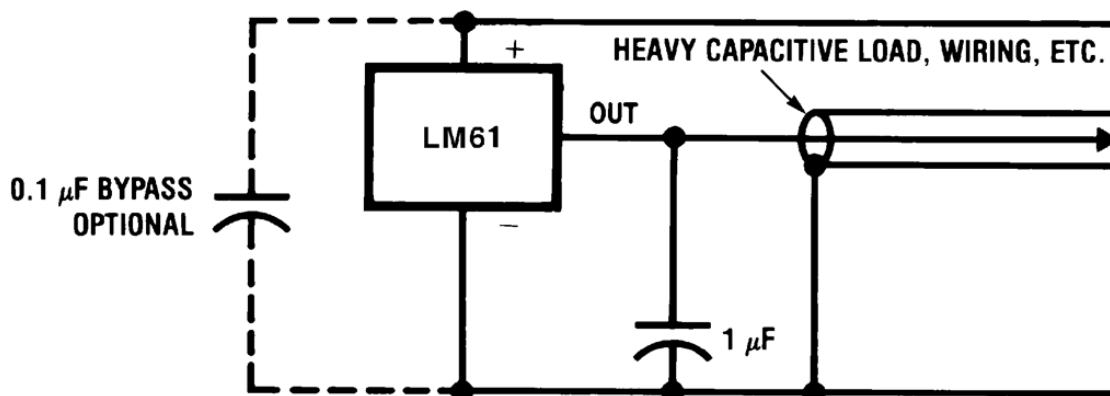

Copyright © 2016, Texas Instruments Incorporated

Figure 13. LM61 with Filter for Noisy Environments

8.2.1.3 Application Curve

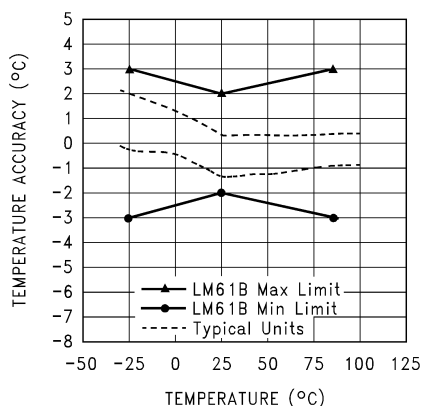
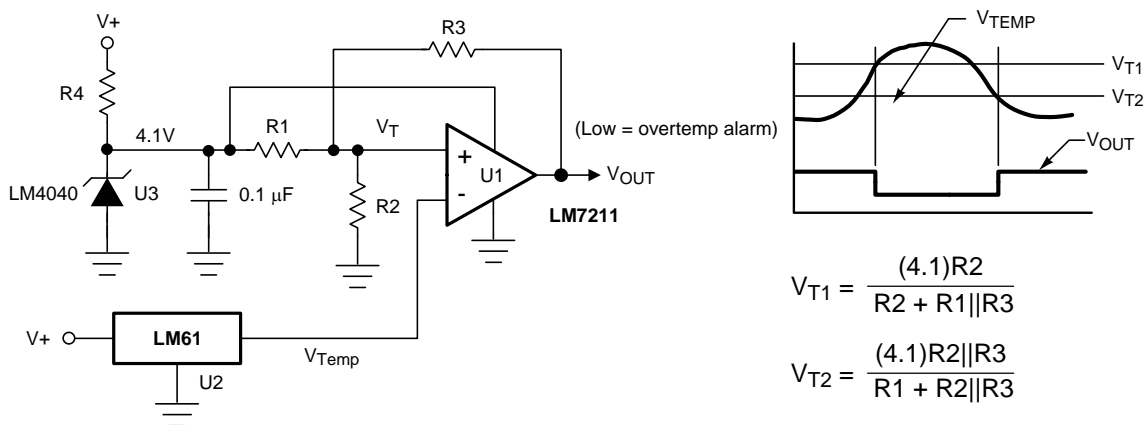

Figure 14. Accuracy vs Temperature

8.2.2 Other Application Circuits

Figure 15 shows an application circuit example using the LM61 device. Customers must fully validate and test any circuit before implementing a design based on an example in this section. Unless otherwise noted, the design procedures in *Typical Temperature Sensing Circuit* are applicable.



Copyright © 2016, Texas Instruments Incorporated

Figure 15. Centigrade Thermostat

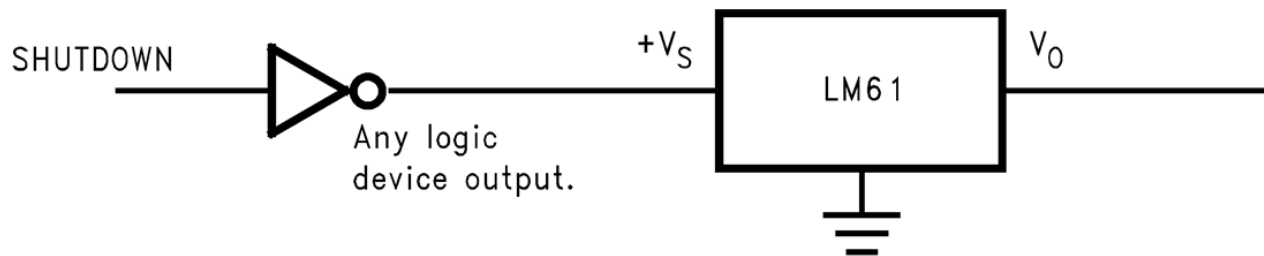

Copyright © 2016, Texas Instruments Incorporated

Figure 16. Conserving Power Dissipation with Shutdown

## 9 Power Supply Recommendations

In an extremely noisy environment, it may be necessary to add filtering to minimize noise pickup. TI recommends a 0.1- $\mu$ F capacitor be added between  $+V_S$  to GND to bypass the power-supply voltage, as shown in [Figure 13](#).

## 10 Layout

### 10.1 Layout Guidelines

#### 10.1.1 Mounting

The LM61 can be applied easily in the same way as other integrated-circuit temperature sensors. It can be glued or cemented to a surface. The temperature that the LM61 senses is within about 0.2°C of the surface temperature that LM61's leads are attached to.

This presumes that the ambient air temperature is almost the same as the surface temperature; if the air temperature is much higher or lower than the surface temperature, the actual temperature measured would be at an intermediate temperature between the surface temperature and the air temperatures.

To ensure good thermal conductivity the backside of the LM61 die is directly attached to the GND pin. The lands and traces to the LM61 are part of the printed-circuit board, which is the object whose temperature is being measured.

Alternatively, the LM61 can be mounted inside a sealed-end metal tube, and can then be dipped into a bath or screwed into a threaded hole in a tank. As with any IC, the LM61 and accompanying wiring and circuits must be kept insulated and dry, to avoid leakage and corrosion. This is especially true if the circuit may operate at cold temperatures where condensation can occur. Printed-circuit coatings and varnishes such as Humiseal and epoxy paints or dips are often used to ensure that moisture cannot corrode the device or connections.

### 10.2 Layout Examples

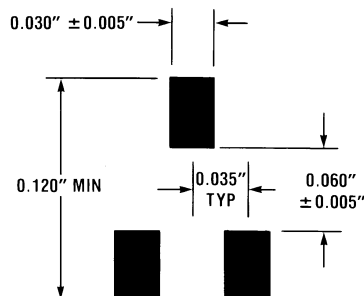
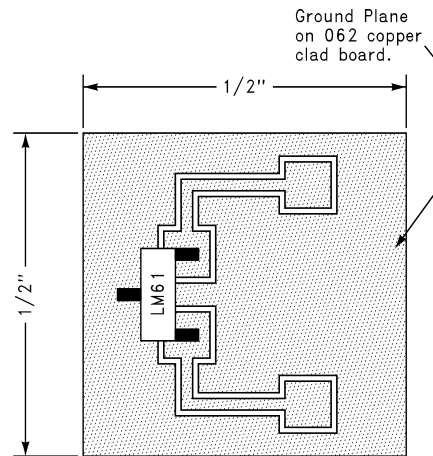
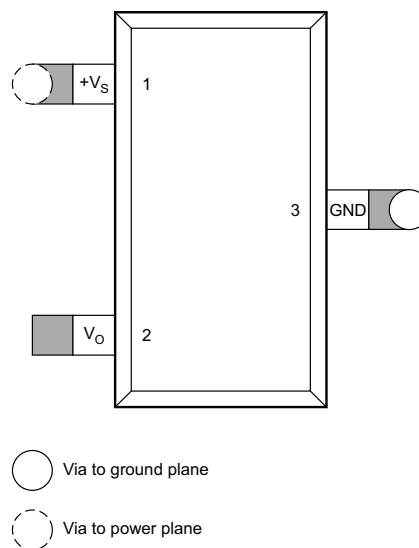

Figure 17. Recommended Solder Pads for SOT-23 Package

**Layout Examples (continued)**

- A. 1/2 in.<sup>2</sup> printed-circuit board with 2 oz copper foil or similar.

**Figure 18. Printed-Circuit Board Used for Heat Sink to Generate All Curves**

**Figure 19. PCB Layout**
**10.3 Thermal Considerations**

The junction-to-ambient thermal resistance is the parameter used to calculate the rise of a device junction temperature due to its power dissipation. For the LM61, [Equation 2](#) is used to calculate the rise in the die temperature.

$$T_J = T_A + R_{\theta JA} \times ((+V_S \times I_Q) + (+V_S - V_O) \times I_L)$$

where

- $I_Q$  is the quiescent current
  - $I_L$  is the load current on the output
- (2)

[Table 2](#) summarizes the rise in die temperature of the LM61 without any loading with a 3.3-V supply, and the thermal resistance for different conditions.

**Table 2. Temperature Rise of LM61 Due to Self-Heating and Thermal Resistance ( $R_{\theta JA}$ )**

			$R_{\theta JA}$ (°C/W)	$T_J - T_A$ (°C)
SOT-23	No heat sink <sup>(1)</sup>	Still air	450	0.26
		Moving air	—	—
	Small heat fin <sup>(2)</sup>	Still air	260	0.13
		Moving air	180	0.09
TO-92	No heat sink <sup>(1)</sup>	Still air	180	0.09
		Moving air	90	0.05
	Small heat fin <sup>(3)</sup>	Still air	140	0.07
		Moving air	70	0.03

(1) Part soldered to 30 gauge wire.

(2) Heat sink used is 1/2 in.<sup>2</sup> printed -circuit board with 2-oz foil with part attached as shown in [Figure 18](#).

(3) Part glued and leads soldered to 1 in.<sup>2</sup> of 1/16 in. printed circuit board with 2-oz foil or similar.

**Table 3. Temperature and Typical  $V_O$  Values**

TEMPERATURE	$V_O$ (TYPICAL)
100°C	1600 mV
85°C	1450 mV
25°C	850 mV
0°C	600 mV
-25°C	350 mV
-30°C	300 mV

## 11 Device and Documentation Support

### 11.1 Related Documentation

For related documentation see the following:

- [TO-92 Packing Options / Ordering Instructions](#) (SNOA072)
- [Tiny Temperature Sensors for Remote Systems](#) (SNIA009)

### 11.2 Receiving Notification of Documentation Updates

To receive notification of documentation updates, navigate to the device product folder on ti.com. In the upper right corner, click on *Alert me* to register and receive a weekly digest of any product information that has changed. For change details, review the revision history included in any revised document.

### 11.3 Community Resources

The following links connect to TI community resources. Linked contents are provided "AS IS" by the respective contributors. They do not constitute TI specifications and do not necessarily reflect TI's views; see TI's [Terms of Use](#).

**TI E2E™ Online Community** *TI's Engineer-to-Engineer (E2E) Community*. Created to foster collaboration among engineers. At e2e.ti.com, you can ask questions, share knowledge, explore ideas and help solve problems with fellow engineers.

**Design Support** *TI's Design Support* Quickly find helpful E2E forums along with design support tools and contact information for technical support.

### 11.4 Trademarks

E2E is a trademark of Texas Instruments.  
All other trademarks are the property of their respective owners.

### 11.5 Electrostatic Discharge Caution



This integrated circuit can be damaged by ESD. Texas Instruments recommends that all integrated circuits be handled with appropriate precautions. Failure to observe proper handling and installation procedures can cause damage.

ESD damage can range from subtle performance degradation to complete device failure. Precision integrated circuits may be more susceptible to damage because very small parametric changes could cause the device not to meet its published specifications.

### 11.6 Glossary

[SLYZ022](#) — *TI Glossary*.

This glossary lists and explains terms, acronyms, and definitions.

## 12 Mechanical, Packaging, and Orderable Information

The following pages include mechanical, packaging, and orderable information. This information is the most current data available for the designated devices. This data is subject to change without notice and revision of this document. For browser-based versions of this data sheet, refer to the left-hand navigation.

PACKAGING INFORMATION

Orderable Device	Status (1)	Package Type	Package Drawing	Pins	Package Qty	Eco Plan (2)	Lead finish/ Ball material (6)	MSL Peak Temp (3)	Op Temp (°C)	Device Marking (4/5)	Samples
LM61BIM3	NRND	SOT-23	DBZ	3	1000	Non-RoHS & Green	Call TI	Level-1-260C-UNLIM	-25 to 85	T1B	
LM61BIM3/NOPB	ACTIVE	SOT-23	DBZ	3	1000	RoHS & Green	SN	Level-1-260C-UNLIM	-25 to 85	T1B	Samples
LM61BIM3X/NOPB	ACTIVE	SOT-23	DBZ	3	3000	RoHS & Green	SN	Level-1-260C-UNLIM	-25 to 85	T1B	Samples
LM61BIZ/LFT3	ACTIVE	TO-92	LP	3	2000	RoHS & Green	SN	N / A for Pkg Type		LM61 BIZ	Samples
LM61BIZ/NOPB	ACTIVE	TO-92	LP	3	1800	RoHS & Green	SN	N / A for Pkg Type	-25 to 85	LM61 BIZ	Samples
LM61CIM3	NRND	SOT-23	DBZ	3	1000	Non-RoHS & Green	Call TI	Level-1-260C-UNLIM	-30 to 100	T1C	
LM61CIM3/NOPB	ACTIVE	SOT-23	DBZ	3	1000	RoHS & Green	SN	Level-1-260C-UNLIM	-30 to 100	T1C	Samples
LM61CIM3X/NOPB	ACTIVE	SOT-23	DBZ	3	3000	RoHS & Green	SN	Level-1-260C-UNLIM	-30 to 100	T1C	Samples
LM61CIZ/LFT2	ACTIVE	TO-92	LP	3	2000	RoHS & Green	SN	N / A for Pkg Type		LM61 CIZ	Samples
LM61CIZ/NOPB	ACTIVE	TO-92	LP	3	1800	RoHS & Green	SN	N / A for Pkg Type	-30 to 100	LM61 CIZ	Samples

(1) The marketing status values are defined as follows:

**ACTIVE:** Product device recommended for new designs.

**LIFEBUY:** TI has announced that the device will be discontinued, and a lifetime-buy period is in effect.

**NRND:** Not recommended for new designs. Device is in production to support existing customers, but TI does not recommend using this part in a new design.

**PREVIEW:** Device has been announced but is not in production. Samples may or may not be available.

**OBSELETE:** TI has discontinued the production of the device.

(2) **RoHS:** TI defines "RoHS" to mean semiconductor products that are compliant with the current EU RoHS requirements for all 10 RoHS substances, including the requirement that RoHS substance do not exceed 0.1% by weight in homogeneous materials. Where designed to be soldered at high temperatures, "RoHS" products are suitable for use in specified lead-free processes. TI may reference these types of products as "Pb-Free".

**RoHS Exempt:** TI defines "RoHS Exempt" to mean products that contain lead but are compliant with EU RoHS pursuant to a specific EU RoHS exemption.

**Green:** TI defines "Green" to mean the content of Chlorine (Cl) and Bromine (Br) based flame retardants meet JS709B low halogen requirements of <=1000ppm threshold. Antimony trioxide based flame retardants must also meet the <=1000ppm threshold requirement.

(3) MSL, Peak Temp. - The Moisture Sensitivity Level rating according to the JEDEC industry standard classifications, and peak solder temperature.

- (4) There may be additional marking, which relates to the logo, the lot trace code information, or the environmental category on the device.
- (5) Multiple Device Markings will be inside parentheses. Only one Device Marking contained in parentheses and separated by a "~" will appear on a device. If a line is indented then it is a continuation of the previous line and the two combined represent the entire Device Marking for that device.
- (6) Lead finish/Ball material - Orderable Devices may have multiple material finish options. Finish options are separated by a vertical ruled line. Lead finish/Ball material values may wrap to two lines if the finish value exceeds the maximum column width.

**Important Information and Disclaimer:** The information provided on this page represents TI's knowledge and belief as of the date that it is provided. TI bases its knowledge and belief on information provided by third parties, and makes no representation or warranty as to the accuracy of such information. Efforts are underway to better integrate information from third parties. TI has taken and continues to take reasonable steps to provide representative and accurate information but may not have conducted destructive testing or chemical analysis on incoming materials and chemicals. TI and TI suppliers consider certain information to be proprietary, and thus CAS numbers and other limited information may not be available for release.

In no event shall TI's liability arising out of such information exceed the total purchase price of the TI part(s) at issue in this document sold by TI to Customer on an annual basis.

**TAPE AND REEL INFORMATION**

**QUADRANT ASSIGNMENTS FOR PIN 1 ORIENTATION IN TAPE**

\*All dimensions are nominal

Device	Package Type	Package Drawing	Pins	SPQ	Reel Diameter (mm)	Reel Width W1 (mm)	A0 (mm)	B0 (mm)	K0 (mm)	P1 (mm)	W (mm)	Pin1 Quadrant
LM61BIM3	SOT-23	DBZ	3	1000	178.0	8.4	3.3	2.9	1.22	4.0	8.0	Q3
LM61BIM3/NOPB	SOT-23	DBZ	3	1000	178.0	8.4	3.3	2.9	1.22	4.0	8.0	Q3
LM61BIM3X/NOPB	SOT-23	DBZ	3	3000	178.0	8.4	3.3	2.9	1.22	4.0	8.0	Q3
LM61CIM3	SOT-23	DBZ	3	1000	178.0	8.4	3.3	2.9	1.22	4.0	8.0	Q3
LM61CIM3/NOPB	SOT-23	DBZ	3	1000	178.0	8.4	3.3	2.9	1.22	4.0	8.0	Q3
LM61CIM3X/NOPB	SOT-23	DBZ	3	3000	178.0	8.4	3.3	2.9	1.22	4.0	8.0	Q3

**TAPE AND REEL BOX DIMENSIONS**

\*All dimensions are nominal

Device	Package Type	Package Drawing	Pins	SPQ	Length (mm)	Width (mm)	Height (mm)
LM61BIM3	SOT-23	DBZ	3	1000	208.0	191.0	35.0
LM61BIM3/NOPB	SOT-23	DBZ	3	1000	208.0	191.0	35.0
LM61BIM3X/NOPB	SOT-23	DBZ	3	3000	208.0	191.0	35.0
LM61CIM3	SOT-23	DBZ	3	1000	208.0	191.0	35.0
LM61CIM3/NOPB	SOT-23	DBZ	3	1000	208.0	191.0	35.0
LM61CIM3X/NOPB	SOT-23	DBZ	3	3000	208.0	191.0	35.0

**GENERIC PACKAGE VIEW**

**DBZ 3**

**SOT-23 - 1.12 mm max height**

SMALL OUTLINE TRANSISTOR

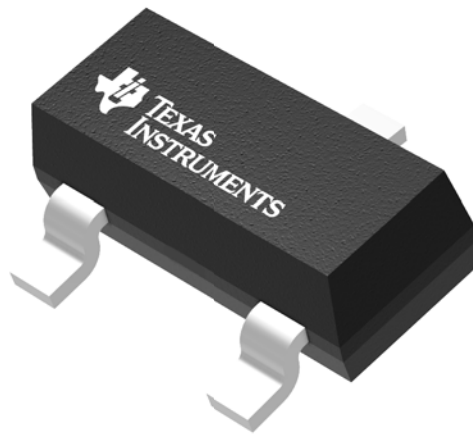

Images above are just a representation of the package family, actual package may vary.  
Refer to the product data sheet for package details.

4203227/C



# EXAMPLE BOARD LAYOUT

DBZ0003A

SOT-23 - 1.12 mm max height

SMALL OUTLINE TRANSISTOR

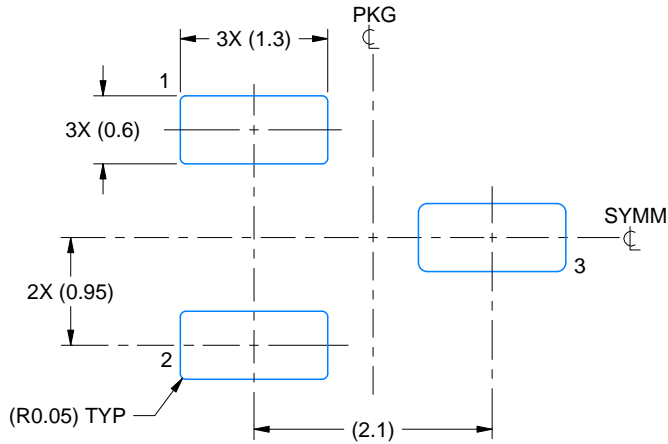

LAND PATTERN EXAMPLE  
SCALE:15X

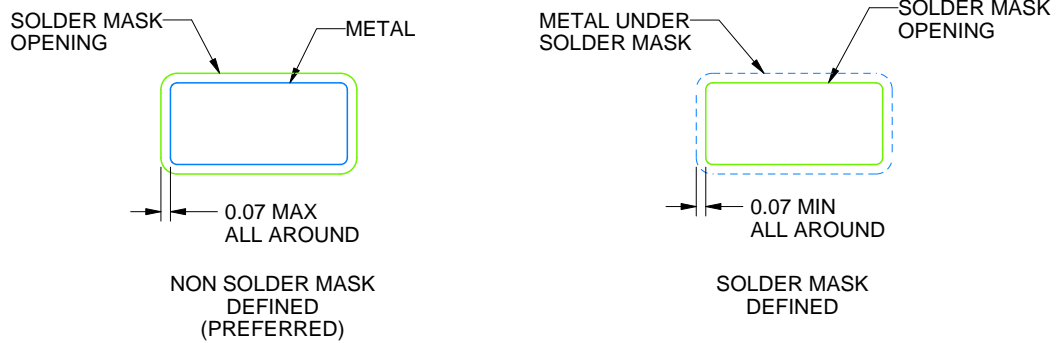

SOLDER MASK DETAILS

4214838/C 04/2017

NOTES: (continued)

4. Publication IPC-7351 may have alternate designs.
5. Solder mask tolerances between and around signal pads can vary based on board fabrication site.

# EXAMPLE STENCIL DESIGN

DBZ0003A

SOT-23 - 1.12 mm max height

SMALL OUTLINE TRANSISTOR

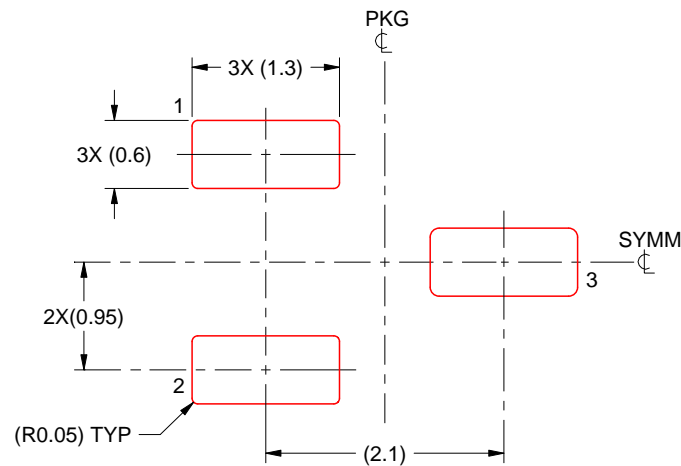

SOLDER PASTE EXAMPLE  
BASED ON 0.125 THICK STENCIL  
SCALE:15X

4214838/C 04/2017

NOTES: (continued)

6. Laser cutting apertures with trapezoidal walls and rounded corners may offer better paste release. IPC-7525 may have alternate design recommendations.
7. Board assembly site may have different recommendations for stencil design.

## GENERIC PACKAGE VIEW

LP 3

TO-92 - 5.34 mm max height

TRANSISTOR OUTLINE



Images above are just a representation of the package family, actual package may vary.  
Refer to the product data sheet for package details.

4040001-2/F

LP0003A



# PACKAGE OUTLINE

TO-92 - 5.34 mm max height

TO-92

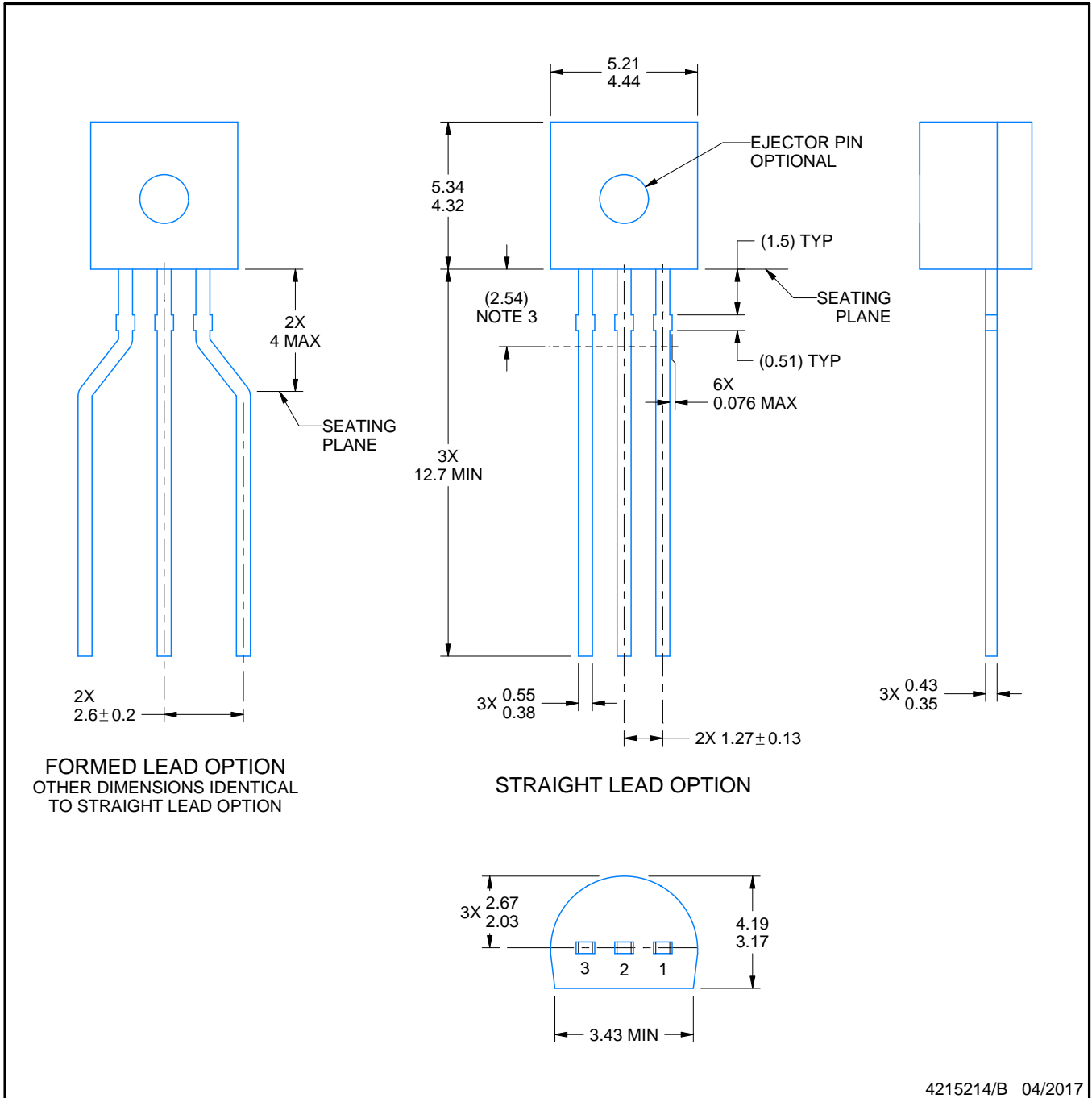

4215214/B 04/2017

**NOTES:**

1. All linear dimensions are in millimeters. Any dimensions in parenthesis are for reference only. Dimensioning and tolerancing per ASME Y14.5M.
2. This drawing is subject to change without notice.
3. Lead dimensions are not controlled within this area.
4. Reference JEDEC TO-226, variation AA.
5. Shipping method:
  - a. Straight lead option available in bulk pack only.
  - b. Formed lead option available in tape and reel or ammo pack.
  - c. Specific products can be offered in limited combinations of shipping medium and lead options.
  - d. Consult product folder for more information on available options.

# EXAMPLE BOARD LAYOUT

LP0003A

TO-92 - 5.34 mm max height

TO-92

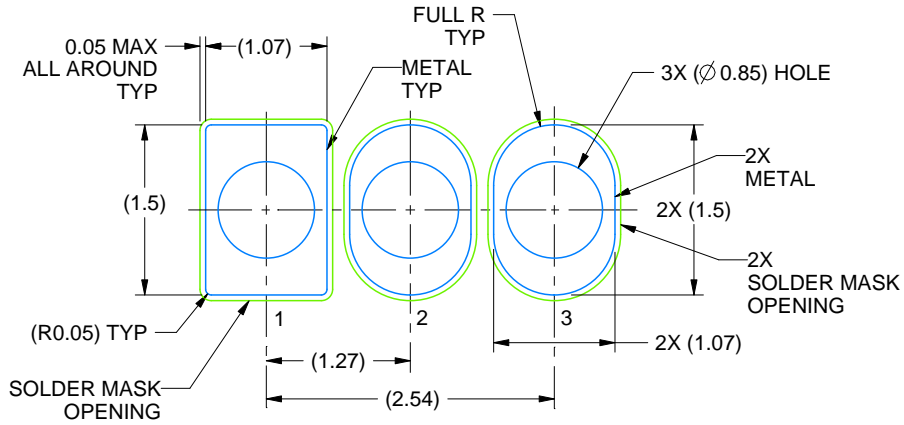

LAND PATTERN EXAMPLE  
STRAIGHT LEAD OPTION  
NON-SOLDER MASK DEFINED  
SCALE:15X

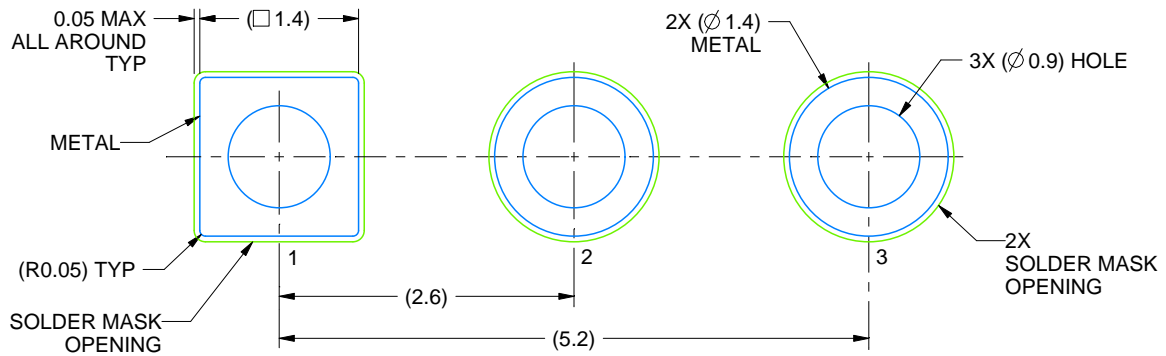

LAND PATTERN EXAMPLE  
FORMED LEAD OPTION  
NON-SOLDER MASK DEFINED  
SCALE:15X

4215214/B 04/2017

# TAPE SPECIFICATIONS

LP0003A

TO-92 - 5.34 mm max height

TO-92

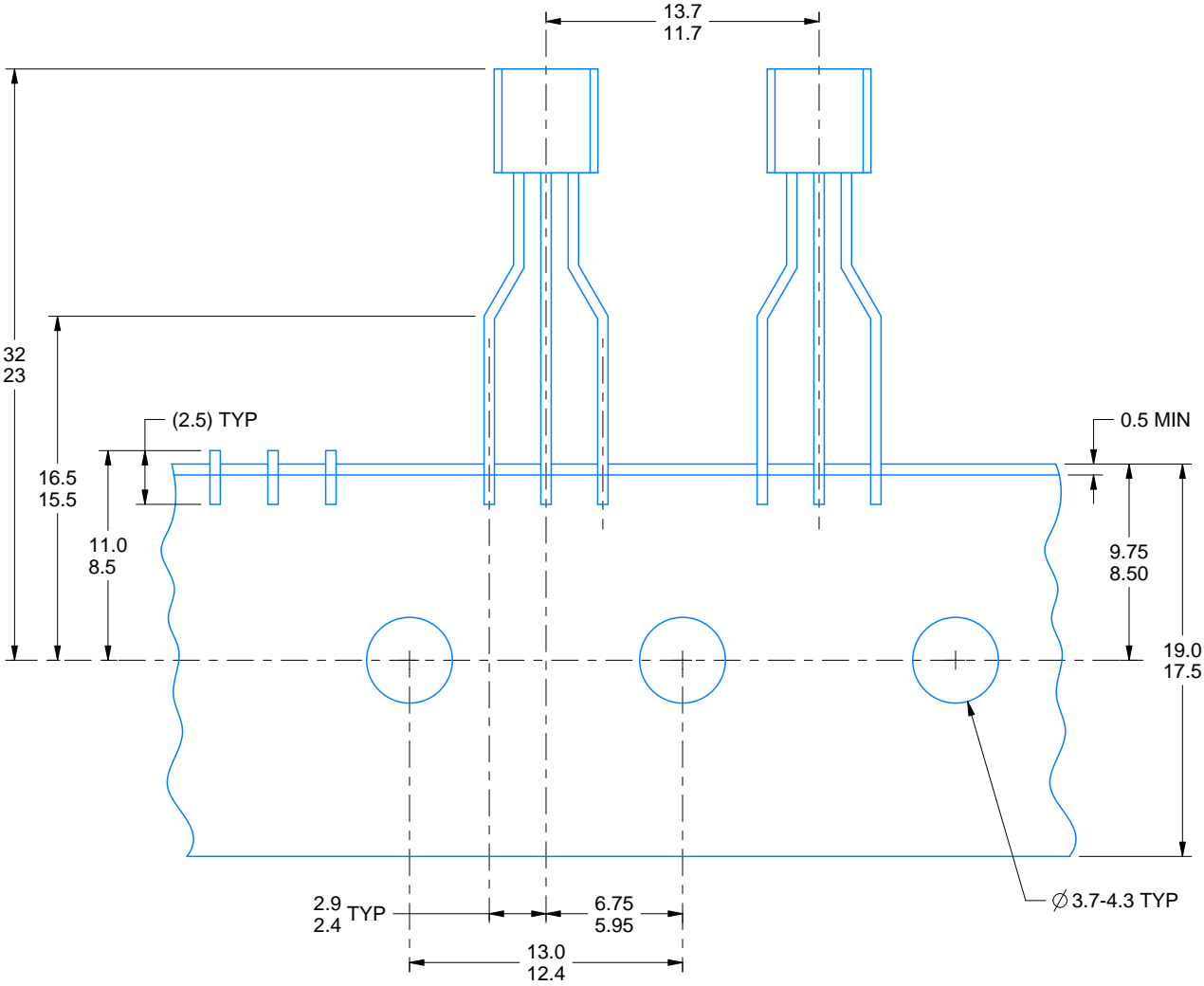

FOR FORMED LEAD OPTION PACKAGE

4215214/B 04/2017

## IMPORTANT NOTICE AND DISCLAIMER

TI PROVIDES TECHNICAL AND RELIABILITY DATA (INCLUDING DATA SHEETS), DESIGN RESOURCES (INCLUDING REFERENCE DESIGNS), APPLICATION OR OTHER DESIGN ADVICE, WEB TOOLS, SAFETY INFORMATION, AND OTHER RESOURCES "AS IS" AND WITH ALL FAULTS, AND DISCLAIMS ALL WARRANTIES, EXPRESS AND IMPLIED, INCLUDING WITHOUT LIMITATION ANY IMPLIED WARRANTIES OF MERCHANTABILITY, FITNESS FOR A PARTICULAR PURPOSE OR NON-INFRINGEMENT OF THIRD PARTY INTELLECTUAL PROPERTY RIGHTS.

These resources are intended for skilled developers designing with TI products. You are solely responsible for (1) selecting the appropriate TI products for your application, (2) designing, validating and testing your application, and (3) ensuring your application meets applicable standards, and any other safety, security, regulatory or other requirements.

These resources are subject to change without notice. TI grants you permission to use these resources only for development of an application that uses the TI products described in the resource. Other reproduction and display of these resources is prohibited. No license is granted to any other TI intellectual property right or to any third party intellectual property right. TI disclaims responsibility for, and you will fully indemnify TI and its representatives against, any claims, damages, costs, losses, and liabilities arising out of your use of these resources.

TI's products are provided subject to [TI's Terms of Sale](#) or other applicable terms available either on [ti.com](#) or provided in conjunction with such TI products. TI's provision of these resources does not expand or otherwise alter TI's applicable warranties or warranty disclaimers for TI products.

TI objects to and rejects any additional or different terms you may have proposed.

Mailing Address: Texas Instruments, Post Office Box 655303, Dallas, Texas 75265  
Copyright © 2021, Texas Instruments Incorporated