

FEATURES

- High-Bandwidth Data Path (up to 500 MHz ⁽¹⁾)
- Equivalent to IDTQS3VH251 Device
- 5-V Tolerant I/Os With Device Powered Up or Powered Down
- Low and Flat ON-State Resistance (r_{on}) Characteristics Over Operating Range ($r_{on} = 4 \Omega$ Typ)
- Rail-to-Rail Switching on Data I/O Ports
 - 0- to 5-V Switching With 3.3-V V_{CC}
 - 0- to 3.3-V Switching With 2.5-V V_{CC}
- Bidirectional Data Flow With Near-Zero Propagation Delay
- Low Input/Output Capacitance Minimizes Loading and Signal Distortion ($C_{io(OFF)} = 3.5$ pF Typ)
- Fast Switching Frequency (f_{OE} or $f_s = 20$ MHz Max)

(1) For additional information regarding the performance characteristics of the CB3Q family, refer to the TI application report, *CBT-C, CB3T, and CB3Q Signal-Switch Families*, literature number SCDA008.

- Data and Control Inputs Provide Undershoot Clamp Diodes
- Low Power Consumption ($I_{CC} = 1$ mA Typ)
- V_{CC} Operating Range From 2.3 V to 3.6 V
- Data I/Os Support 0- to 5-V Signaling Levels (0.8 V, 1.2 V, 1.5 V, 1.8 V, 2.5 V, 3.3 V, 5 V)
- Control Inputs Can Be Driven by TTL or 5-V/3.3-V CMOS Outputs
- I_{off} Supports Partial-Power-Down Mode Operation
- Latch-Up Performance Exceeds 100 mA Per JESD 78, Class II
- ESD Performance Tested Per JESD 22
 - 2000-V Human-Body Model (A114-B, Class II)
 - 1000-V Charged-Device Model (C101)
- Supports Both Digital and Analog Applications: PCI Interface, Differential Signal Interface, Memory Interleaving, Bus Isolation, Low-Distortion Signal Gating

DBQ, DGV, OR PW PACKAGE
(TOP VIEW)

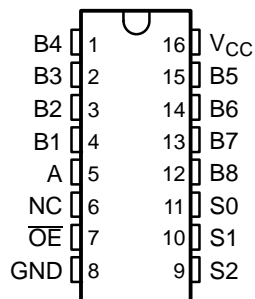

NC - No internal connection

RGY PACKAGE
(TOP VIEW)

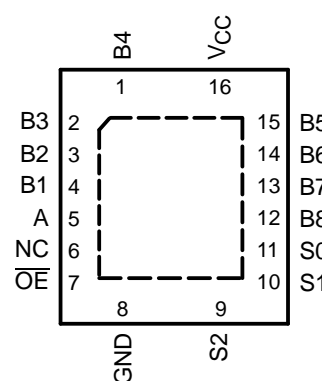

NC - No internal connection

DESCRIPTION/ORDERING INFORMATION

The SN74CB3Q3251 is a high-bandwidth FET bus switch utilizing a charge pump to elevate the gate voltage of the pass transistor, providing a low and flat ON-state resistance (r_{on}). The low and flat ON-state resistance allows for minimal propagation delay and supports rail-to-rail switching on the data input/output (I/O) ports. The device also features low data I/O capacitance to minimize capacitive loading and signal distortion on the data bus. Specifically designed to support high-bandwidth applications, the SN74CB3Q3251 provides an optimized interface solution ideally suited for broadband communications, networking, and data-intensive computing systems.



Please be aware that an important notice concerning availability, standard warranty, and use in critical applications of Texas Instruments semiconductor products and disclaimers thereto appears at the end of this data sheet.

SN74CB3Q3251
1-OF-8 FET MULTIPLEXER/DEMULTIPLEXER
2.5-V/3.3-V LOW-VOLTAGE HIGH-BANDWIDTH BUS SWITCH

SCDS173A–AUGUST 2004–REVISED MARCH 2005

DESCRIPTION/ORDERING INFORMATION (CONTINUED)

The SN74CB3Q3251 is a 1-of-8 multiplexer/demultiplexer with a single output-enable (\overline{OE}) input. The select (S0, S1, S2) inputs control the data path of the multiplexer/demultiplexer. When \overline{OE} is low, the multiplexer/demultiplexer is enabled, and the A port is connected to the B port, allowing bidirectional data flow between ports. When \overline{OE} is high, the multiplexer/demultiplexer is disabled, and a high-impedance state exists between the A and B ports.

This device is fully specified for partial-power-down applications using I_{off} . The I_{off} circuitry prevents damaging current backflow through the device when it is powered down. The device has isolation during power off.

To ensure the high-impedance state during power up or power down, \overline{OE} should be tied to V_{CC} through a pullup resistor; the minimum value of the resistor is determined by the current-sinking capability of the driver.

ORDERING INFORMATION

T _A	PACKAGE ⁽¹⁾		ORDERABLE PART NUMBER	TOP-SIDE MARKING
–40°C to 85°C	QFN – RGY	Tape and reel	SN74CB3Q3251RGYR	BU251
	SSOP (QSOP) – DBQ	Tape and reel	SN74CB3Q3251DBQR	BU251
	TSSOP – PW	Tube	SN74CB3Q3251PW	BU251
		Tape and reel	SN74CB3Q3251PWR	
	TVSOP – DGV	Tape and reel	SN74CB3Q3251DGVR	BU251

(1) Package drawings, standard packing quantities, thermal data, symbolization, and PCB design guidelines are available at www.ti.com/sc/package.

FUNCTION TABLE

INPUTS				INPUT/OUTPUT A	FUNCTION
\overline{OE}	S2	S1	S0		
L	L	L	L	B1	A port = B1 port
L	L	L	H	B2	A port = B2 port
L	L	H	L	B3	A port = B3 port
L	L	H	H	B4	A port = B4 port
L	H	L	L	B5	A port = B5 port
L	H	L	H	B6	A port = B6 port
L	H	H	L	B7	A port = B7 port
L	H	H	H	B8	A port = B8 port
H	X	X	X	Z	Disconnect

LOGIC DIAGRAM (POSITIVE LOGIC)

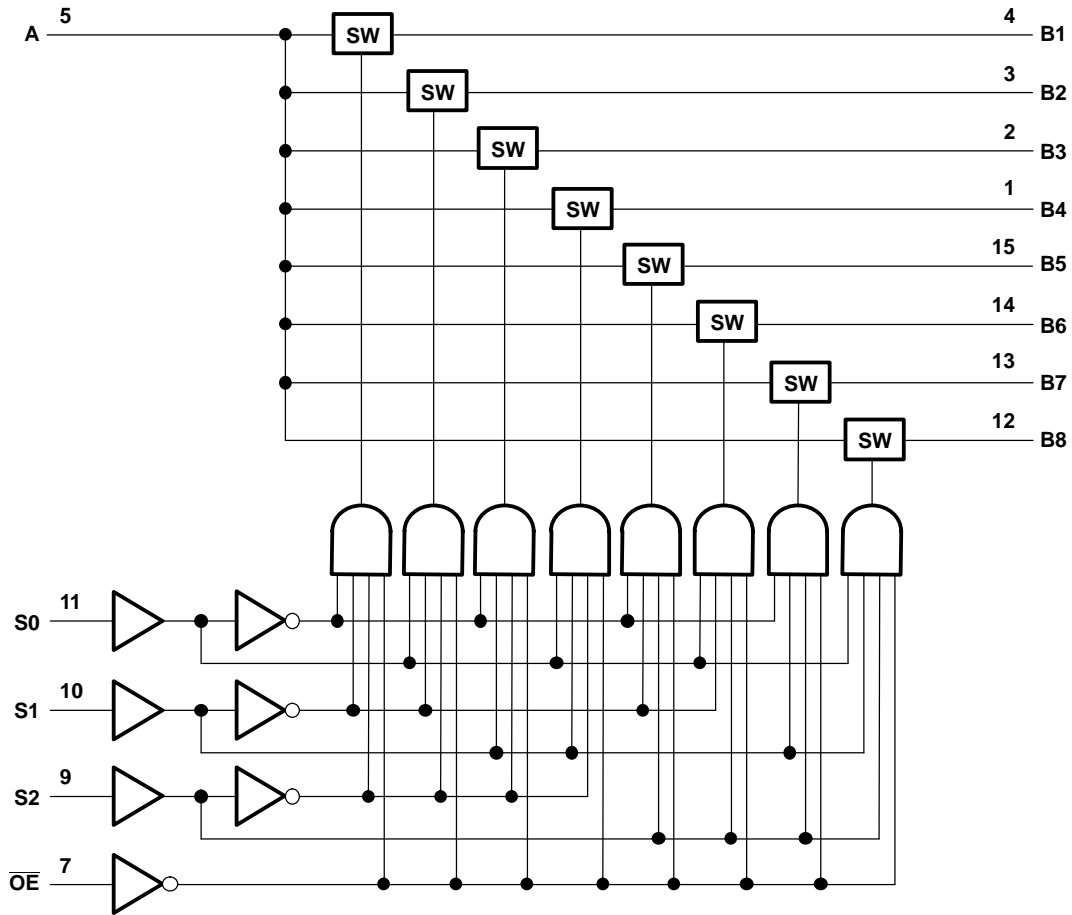

SIMPLIFIED SCHEMATIC, EACH FET SWITCH (SW)

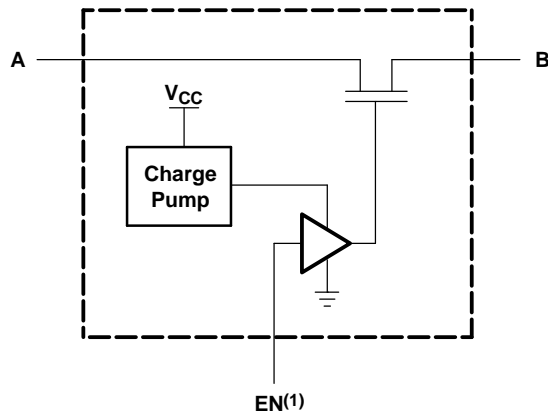

(1) EN is the internal enable signal applied to the switch.

SN74CB3Q3251
1-OF-8 FET MULTIPLEXER/DEMULTIPLEXER
2.5-V/3.3-V LOW-VOLTAGE HIGH-BANDWIDTH BUS SWITCH

SCDS173A–AUGUST 2004–REVISED MARCH 2005

Absolute Maximum Ratings⁽¹⁾

over operating free-air temperature range (unless otherwise noted)

		MIN	MAX	UNIT
V _{CC}	Supply voltage range	–0.5	4.6	V
V _{IN}	Control input voltage range ⁽²⁾⁽³⁾	–0.5	7	V
V _{I/O}	Switch I/O voltage range ⁽²⁾⁽³⁾⁽⁴⁾	–0.5	7	V
I _{IK}	Control input clamp current	V _{IN} < 0	–50	mA
I _{I/O} K	I/O port clamp current	V _{I/O} < 0	–50	mA
I _{I/O}	ON-state switch current ⁽⁵⁾		±64	mA
	Continuous current through V _{CC} or GND		±100	mA
θ _{JA}	Package thermal impedance	DBQ package ⁽⁶⁾	90	°C/W
		DGV package ⁽⁶⁾	120	
		PW package ⁽⁶⁾	108	
		RGY package ⁽⁷⁾	39	
T _{stg}	Storage temperature range	–65	150	°C

- (1) Stresses beyond those listed under "absolute maximum ratings" may cause permanent damage to the device. These are stress ratings only, and functional operation of the device at these or any other conditions beyond those indicated under "recommended operating conditions" is not implied. Exposure to absolute-maximum-rated conditions for extended periods may affect device reliability.
- (2) All voltages are with respect to ground unless otherwise specified.
- (3) The input and output voltage ratings may be exceeded if the input and output clamp-current ratings are observed.
- (4) V_I and V_O are used to denote specific conditions for V_{I/O}.
- (5) I_I and I_O are used to denote specific conditions for I_{I/O}.
- (6) The package thermal impedance is calculated in accordance with JESD 51-7.
- (7) The package thermal impedance is calculated in accordance with JESD 51-5.

Recommended Operating Conditions⁽¹⁾

		MIN	MAX	UNIT	
V _{CC}	Supply voltage	2.3	3.6	V	
V _{IH}	High-level control input voltage	V _{CC} = 2.3 V to 2.7 V	1.7	5.5	V
		V _{CC} = 2.7 V to 3.6 V	2	5.5	
V _{IL}	Low-level control input voltage	V _{CC} = 2.3 V to 2.7 V	0	0.7	V
		V _{CC} = 2.7 V to 3.6 V	0	0.8	
V _{I/O}	Data input/output voltage	0	5.5	V	
T _A	Operating free-air temperature	–40	85	°C	

- (1) All unused control inputs of the device must be held at V_{CC} or GND to ensure proper device operation. Refer to the TI application report, *Implications of Slow or Floating CMOS Inputs*, literature number SCBA004.

Electrical Characteristics⁽¹⁾

over recommended operating free-air temperature range (unless otherwise noted)

PARAMETER		TEST CONDITIONS			MIN	TYP ⁽²⁾	MAX	UNIT
V_{IK}		$V_{CC} = 3.6\text{ V}$,	$I_I = -18\text{ mA}$				-1.8	V
I_{IN}	Control inputs	$V_{CC} = 3.6\text{ V}$,	$V_{IN} = 0\text{ to }5.5\text{ V}$				±1	μA
I_{OZ} ⁽³⁾		$V_{CC} = 3.6\text{ V}$,	$V_O = 0\text{ to }5.5\text{ V}$, $V_I = 0$,	Switch OFF, $V_{IN} = V_{CC}\text{ or GND}$			±1	μA
I_{off}		$V_{CC} = 0$,	$V_O = 0\text{ to }5.5\text{ V}$,	$V_I = 0$			1	μA
I_{CC}		$V_{CC} = 3.6\text{ V}$,	$I_{I/O} = 0$, Switch ON or OFF,	$V_{IN} = V_{CC}\text{ or GND}$		1	4	mA
ΔI_{CC} ⁽⁴⁾	Control inputs	$V_{CC} = 3.6\text{ V}$,	One input at 3 V,	Other inputs at V_{CC} or GND			30	μA
I_{CCD} ⁽⁵⁾		$V_{CC} = 3.6\text{ V}$,	A and B ports open, Control input switching at 50% duty cycle			0.03	0.1	mA/MHz
C_{in}		$V_{CC} = 3.3\text{ V}$,	$V_{IN} = 5.5\text{ V}, 3.3\text{ V},\text{ or }0$			2.5	4.5	pF
$C_{io(OFF)}$	A port	$V_{CC} = 3.3\text{ V}$,	Switch OFF, $V_{IN} = V_{CC}\text{ or GND}$,	$V_{I/O} = 5.5\text{ V}, 3.3\text{ V},\text{ or }0$		19.5	25	pF
	B port	$V_{CC} = 3.3\text{ V}$,	Switch OFF, $V_{IN} = V_{CC}\text{ or GND}$,	$V_{I/O} = 5.5\text{ V}, 3.3\text{ V},\text{ or }0$		3.5	4.5	
$C_{io(ON)}$		$V_{CC} = 3.3\text{ V}$,	Switch ON, $V_{IN} = V_{CC}\text{ or GND}$,	$V_{I/O} = 5.5\text{ V}, 3.3\text{ V},\text{ or }0$		15	19	pF
r_{on} ⁽⁶⁾	$V_{CC} = 2.3\text{ V}$, TYP at $V_{CC} = 2.5\text{ V}$	$V_I = 0$,	$I_O = 30\text{ mA}$			4	10	Ω
		$V_I = 1.7\text{ V}$,	$I_O = -15\text{ mA}$			4.5	11	
	$V_{CC} = 3\text{ V}$	$V_I = 0$,	$I_O = 30\text{ mA}$			3.5	8	
		$V_I = 2.4\text{ V}$,	$I_O = -15\text{ mA}$			4	10	

- (1) V_{IN} and I_{IN} refer to control inputs. V_I , V_O , I_I , and I_O refer to data pins.
- (2) All typical values are at $V_{CC} = 3.3\text{ V}$ (unless otherwise noted), $T_A = 25^\circ\text{C}$.
- (3) For I/O ports, the parameter I_{OZ} includes the input leakage current.
- (4) This is the increase in supply current for each input that is at the specified TTL voltage level, rather than V_{CC} or GND.
- (5) This parameter specifies the dynamic power-supply current associated with the operating frequency of a single control input (see Figure 2).
- (6) Measured by the voltage drop between the A and B terminals at the indicated current through the switch. ON-state resistance is determined by the lower of the voltages of the two (A or B) terminals.

Switching Characteristics

over recommended operating free-air temperature range (unless otherwise noted) (see Figure 3)

PARAMETER	FROM (INPUT)	TO (OUTPUT)	$V_{CC} = 2.5\text{ V} \pm 0.2\text{ V}$		$V_{CC} = 3.3\text{ V} \pm 0.3\text{ V}$		UNIT
			MIN	MAX	MIN	MAX	
f_{OE} or f_S ⁽¹⁾	\overline{OE} or S	A or B	10		20		MHz
t_{pd} ⁽²⁾	A or B	B or A	0.12		0.18		ns
$t_{pd(s)}$	S	A	1.5	6.7	1.5	5.9	ns
	\overline{OE}	B	1.5	6.7	1.5	5.9	
t_{dis}	S	B	0.5	6.1	0.5	6.1	ns
	\overline{OE}	A or B	0.5	6.1	0.5	6.1	

- (1) Maximum switching frequency for control input ($V_O > V_{CC}$, $V_I = 5\text{ V}$, $R_L \geq 1\text{ M}\Omega$, $C_L = 0$).
- (2) The propagation delay is the calculated RC time constant of the typical ON-state resistance of the switch and the specified load capacitance, when driven by an ideal voltage source (zero output impedance).

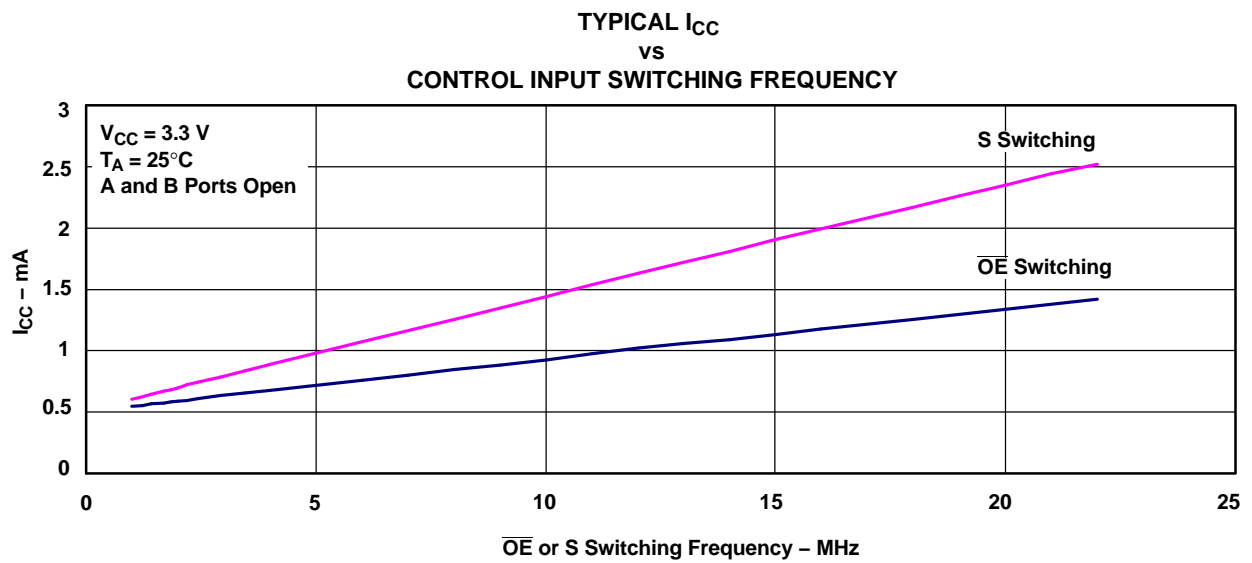
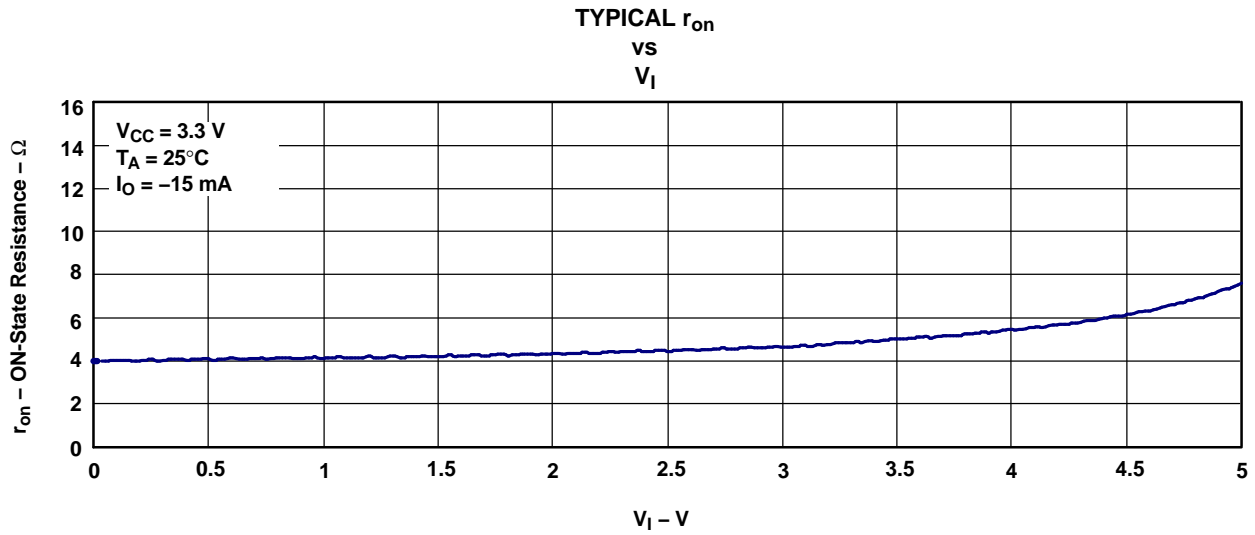

PARAMETER MEASUREMENT INFORMATION

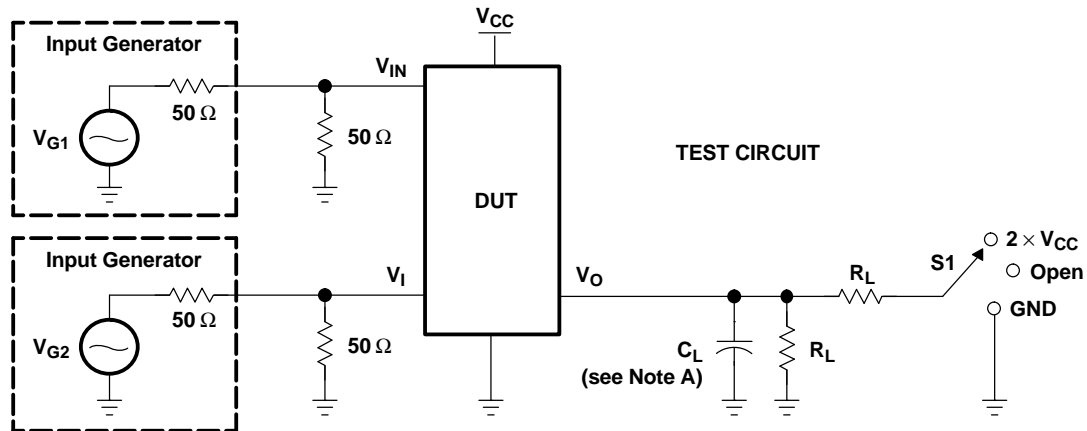

TEST	V _{CC}	S1	R _L	V _I	C _L	V _Δ
t _{pd} (s)	2.5 V ± 0.2 V	Open	500 Ω	V _{CC} or GND	30 pF	
	3.3 V ± 0.3 V	Open	500 Ω	V _{CC} or GND	50 pF	
t _{PLZ} /t _{PZL}	2.5 V ± 0.2 V	2 × V _{CC}	500 Ω	GND	30 pF	0.15 V
	3.3 V ± 0.3 V	2 × V _{CC}	500 Ω	GND	50 pF	0.3 V
t _{PHZ} /t _{PZH}	2.5 V ± 0.2 V	GND	500 Ω	V _{CC}	30 pF	0.15 V
	3.3 V ± 0.3 V	GND	500 Ω	V _{CC}	50 pF	0.3 V

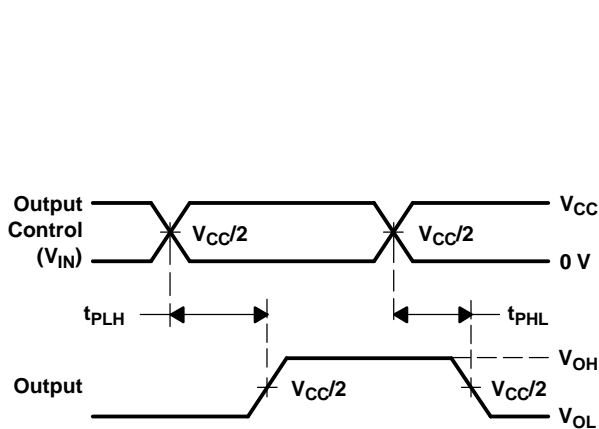

VOLTAGE WAVEFORMS
PROPAGATION DELAY TIMES (t_{pd}(s))

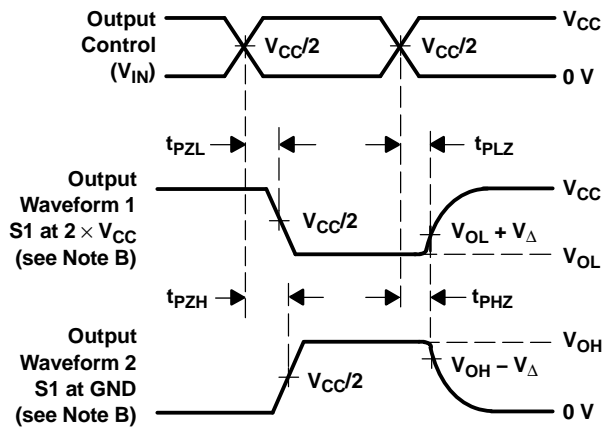

VOLTAGE WAVEFORMS
ENABLE AND DISABLE TIMES

- NOTES:
- A. C_L includes probe and jig capacitance.
 - B. Waveform 1 is for an output with internal conditions such that the output is low, except when disabled by the output control. Waveform 2 is for an output with internal conditions such that the output is high, except when disabled by the output control.
 - C. All input pulses are supplied by generators having the following characteristics: PRR ≤ 10 MHz, Z_O = 50 Ω, t_r ≤ 2.5 ns, t_f ≤ 2.5 ns.
 - D. The outputs are measured one at a time, with one transition per measurement.
 - E. t_{PLZ} and t_{PHZ} are the same as t_{dis}.
 - F. t_{PZL} and t_{PZH} are the same as t_{en}.
 - G. t_{PLH} and t_{PHL} are the same as t_{pd}(s). The t_{pd} propagation delay is the calculated RC time constant of the typical ON-state resistance of the switch and the specified load capacitance, when driven by an ideal voltage source (zero output impedance).
 - H. All parameters and waveforms are not applicable to all devices.

Figure 3. Test Circuit and Voltage Waveforms

PACKAGING INFORMATION

Orderable Device	Status (1)	Package Type	Package Drawing	Pins	Package Qty	Eco Plan (2)	Lead finish/ Ball material (6)	MSL Peak Temp (3)	Op Temp (°C)	Device Marking (4/5)	Samples
SN74CB3Q3251DBQR	ACTIVE	SSOP	DBQ	16	2500	RoHS & Green	NIPDAU	Level-2-260C-1 YEAR	-40 to 85	BU251	Samples
SN74CB3Q3251DGVR	ACTIVE	TVSOP	DGV	16	2000	RoHS & Green	NIPDAU	Level-1-260C-UNLIM	-40 to 85	BU251	Samples
SN74CB3Q3251PW	ACTIVE	TSSOP	PW	16	90	RoHS & Green	NIPDAU	Level-1-260C-UNLIM	-40 to 85	BU251	Samples
SN74CB3Q3251PWR	ACTIVE	TSSOP	PW	16	2000	RoHS & Green	NIPDAU	Level-1-260C-UNLIM	-40 to 85	BU251	Samples
SN74CB3Q3251RGYR	ACTIVE	VQFN	RGY	16	3000	RoHS & Green	NIPDAU	Level-2-260C-1 YEAR	-40 to 85	BZ51	Samples

(1) The marketing status values are defined as follows:

ACTIVE: Product device recommended for new designs.

LIFEBUY: TI has announced that the device will be discontinued, and a lifetime-buy period is in effect.

NRND: Not recommended for new designs. Device is in production to support existing customers, but TI does not recommend using this part in a new design.

PREVIEW: Device has been announced but is not in production. Samples may or may not be available.

OBSOLETE: TI has discontinued the production of the device.

(2) **RoHS:** TI defines "RoHS" to mean semiconductor products that are compliant with the current EU RoHS requirements for all 10 RoHS substances, including the requirement that RoHS substance do not exceed 0.1% by weight in homogeneous materials. Where designed to be soldered at high temperatures, "RoHS" products are suitable for use in specified lead-free processes. TI may reference these types of products as "Pb-Free".

RoHS Exempt: TI defines "RoHS Exempt" to mean products that contain lead but are compliant with EU RoHS pursuant to a specific EU RoHS exemption.

Green: TI defines "Green" to mean the content of Chlorine (Cl) and Bromine (Br) based flame retardants meet JS709B low halogen requirements of <=1000ppm threshold. Antimony trioxide based flame retardants must also meet the <=1000ppm threshold requirement.

(3) MSL, Peak Temp. - The Moisture Sensitivity Level rating according to the JEDEC industry standard classifications, and peak solder temperature.

(4) There may be additional marking, which relates to the logo, the lot trace code information, or the environmental category on the device.

(5) Multiple Device Markings will be inside parentheses. Only one Device Marking contained in parentheses and separated by a "~" will appear on a device. If a line is indented then it is a continuation of the previous line and the two combined represent the entire Device Marking for that device.

(6) Lead finish/Ball material - Orderable Devices may have multiple material finish options. Finish options are separated by a vertical ruled line. Lead finish/Ball material values may wrap to two lines if the finish value exceeds the maximum column width.

Important Information and Disclaimer: The information provided on this page represents TI's knowledge and belief as of the date that it is provided. TI bases its knowledge and belief on information provided by third parties, and makes no representation or warranty as to the accuracy of such information. Efforts are underway to better integrate information from third parties. TI has taken and continues to take reasonable steps to provide representative and accurate information but may not have conducted destructive testing or chemical analysis on incoming materials and chemicals. TI and TI suppliers consider certain information to be proprietary, and thus CAS numbers and other limited information may not be available for release.

In no event shall TI's liability arising out of such information exceed the total purchase price of the TI part(s) at issue in this document sold by TI to Customer on an annual basis.

TAPE AND REEL INFORMATION

QUADRANT ASSIGNMENTS FOR PIN 1 ORIENTATION IN TAPE

*All dimensions are nominal

Device	Package Type	Package Drawing	Pins	SPQ	Reel Diameter (mm)	Reel Width W1 (mm)	A0 (mm)	B0 (mm)	K0 (mm)	P1 (mm)	W (mm)	Pin1 Quadrant
SN74CB3Q3251DBQR	SSOP	DBQ	16	2500	330.0	12.5	6.4	5.2	2.1	8.0	12.0	Q1
SN74CB3Q3251DGVR	TVSOP	DGV	16	2000	330.0	12.4	6.8	4.0	1.6	8.0	12.0	Q1
SN74CB3Q3251PWR	TSSOP	PW	16	2000	330.0	12.4	6.9	5.6	1.6	8.0	12.0	Q1
SN74CB3Q3251RGYR	VQFN	RGY	16	3000	330.0	12.4	3.8	4.3	1.5	8.0	12.0	Q1

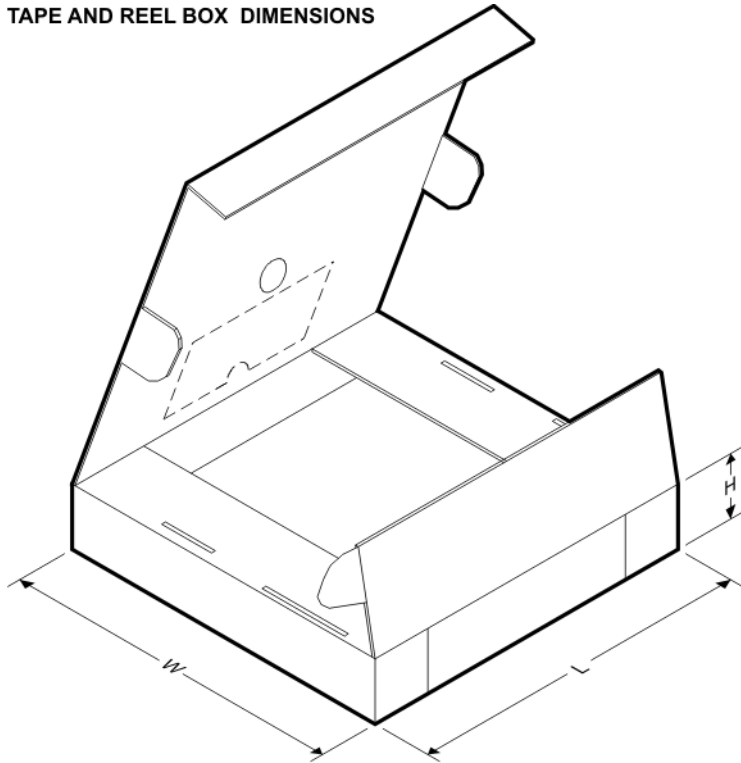
TAPE AND REEL BOX DIMENSIONS

*All dimensions are nominal

Device	Package Type	Package Drawing	Pins	SPQ	Length (mm)	Width (mm)	Height (mm)
SN74CB3Q3251DBQR	SSOP	DBQ	16	2500	340.5	338.1	20.6
SN74CB3Q3251DGVR	TVSOP	DGV	16	2000	367.0	367.0	35.0
SN74CB3Q3251PWR	TSSOP	PW	16	2000	367.0	367.0	35.0
SN74CB3Q3251RGYR	VQFN	RGY	16	3000	367.0	367.0	35.0

TUBE

*All dimensions are nominal

Device	Package Name	Package Type	Pins	SPQ	L (mm)	W (mm)	T (μm)	B (mm)
SN74CB3Q3251PW	PW	TSSOP	16	90	530	10.2	3600	3.5



4220204/A 02/2017

NOTES:

1. All linear dimensions are in millimeters. Any dimensions in parenthesis are for reference only. Dimensioning and tolerancing per ASME Y14.5M.
2. This drawing is subject to change without notice.
3. This dimension does not include mold flash, protrusions, or gate burrs. Mold flash, protrusions, or gate burrs shall not exceed 0.15 mm per side.
4. This dimension does not include interlead flash. Interlead flash shall not exceed 0.25 mm per side.
5. Reference JEDEC registration MO-153.

EXAMPLE BOARD LAYOUT

PW0016A

TSSOP - 1.2 mm max height

SMALL OUTLINE PACKAGE



LAND PATTERN EXAMPLE
EXPOSED METAL SHOWN
SCALE: 10X



SOLDER MASK DETAILS

4220204/A 02/2017

NOTES: (continued)

- 6. Publication IPC-7351 may have alternate designs.
- 7. Solder mask tolerances between and around signal pads can vary based on board fabrication site.

EXAMPLE STENCIL DESIGN

PW0016A

TSSOP - 1.2 mm max height

SMALL OUTLINE PACKAGE



SOLDER PASTE EXAMPLE
BASED ON 0.125 mm THICK STENCIL
SCALE: 10X

4220204/A 02/2017

NOTES: (continued)

8. Laser cutting apertures with trapezoidal walls and rounded corners may offer better paste release. IPC-7525 may have alternate design recommendations.
9. Board assembly site may have different recommendations for stencil design.

DGV (R-PDSO-G**)

PLASTIC SMALL-OUTLINE

24 PINS SHOWN



4073251/E 08/00

- NOTES: A. All linear dimensions are in millimeters.
 B. This drawing is subject to change without notice.
 C. Body dimensions do not include mold flash or protrusion, not to exceed 0,15 per side.
 D. Falls within JEDEC: 24/48 Pins – MO-153
 14/16/20/56 Pins – MO-194

EXAMPLE BOARD LAYOUT

DBQ0016A

SSOP - 1.75 mm max height

SHRINK SMALL-OUTLINE PACKAGE

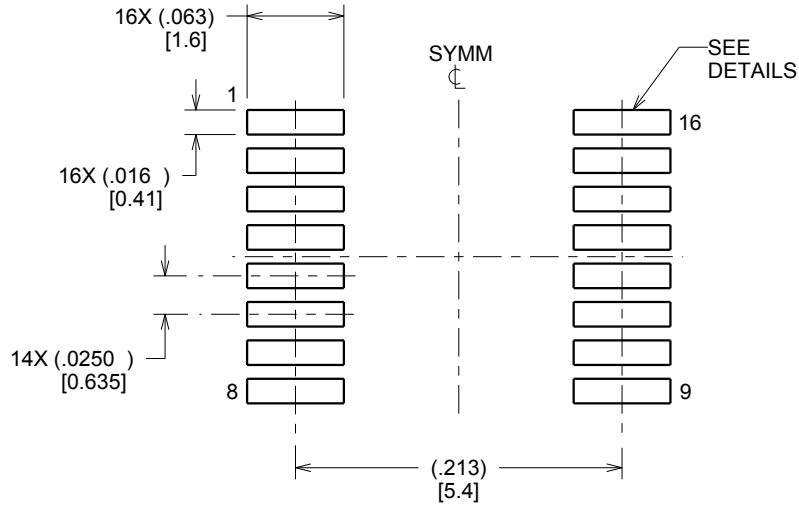

LAND PATTERN EXAMPLE
SCALE:8X

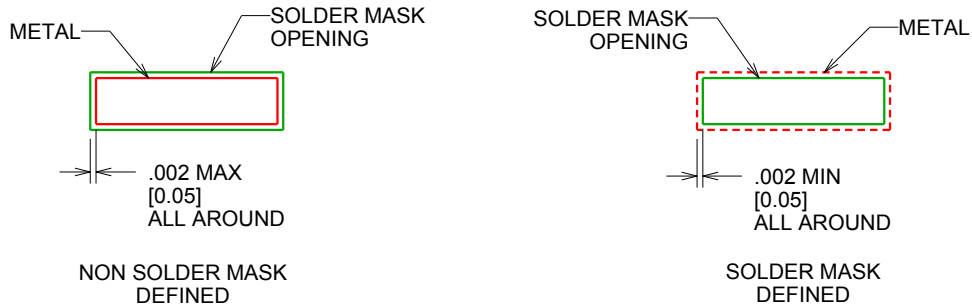

SOLDER MASK DETAILS

4214846/A 03/2014

NOTES: (continued)

- 6. Publication IPC-7351 may have alternate designs.
- 7. Solder mask tolerances between and around signal pads can vary based on board fabrication site.

EXAMPLE STENCIL DESIGN

DBQ0016A

SSOP - 1.75 mm max height

SHRINK SMALL-OUTLINE PACKAGE

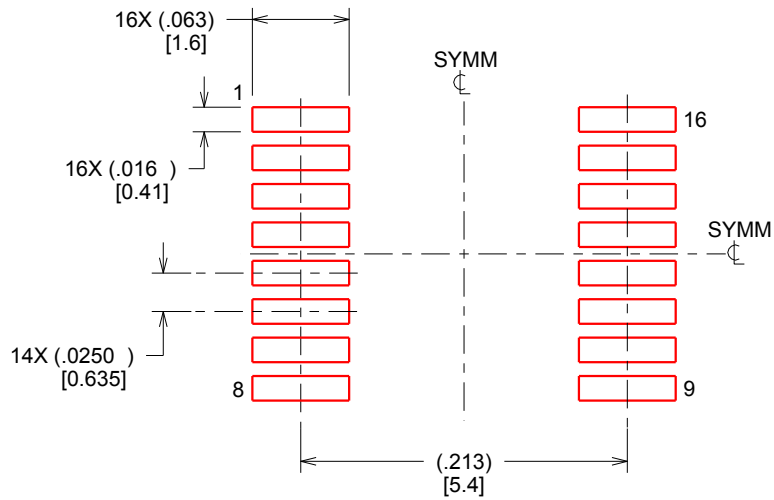

SOLDER PASTE EXAMPLE
BASED ON .005 INCH [0.127 MM] THICK STENCIL
SCALE:8X

4214846/A 03/2014

NOTES: (continued)

8. Laser cutting apertures with trapezoidal walls and rounded corners may offer better paste release. IPC-7525 may have alternate design recommendations.
9. Board assembly site may have different recommendations for stencil design.

RGY (R-PVQFN-N16)

PLASTIC QUAD FLATPACK NO-LEAD

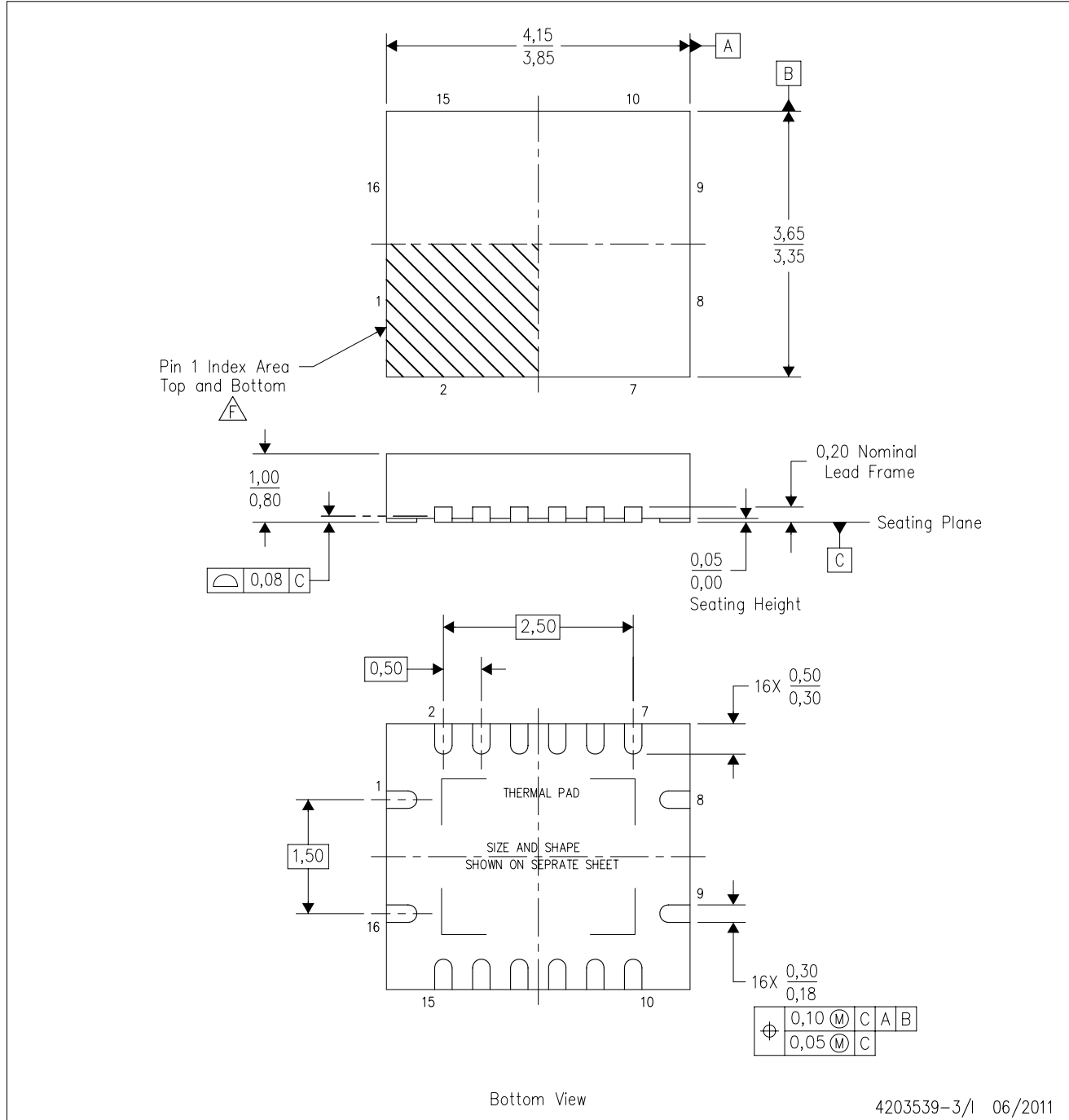

4203539-3/1 06/2011

- NOTES:
- All linear dimensions are in millimeters. Dimensioning and tolerancing per ASME Y14.5M-1994.
 - This drawing is subject to change without notice.
 - QFN (Quad Flatpack No-Lead) package configuration.
 - The package thermal pad must be soldered to the board for thermal and mechanical performance.
 - See the additional figure in the Product Data Sheet for details regarding the exposed thermal pad features and dimensions.
 - Pin 1 identifiers are located on both top and bottom of the package and within the zone indicated. The Pin 1 identifiers are either a molded, marked, or metal feature.
 - Package complies to JEDEC MO-241 variation BA.

RGY (R-PVQFN-N16)

PLASTIC QUAD FLATPACK NO-LEAD

THERMAL INFORMATION

This package incorporates an exposed thermal pad that is designed to be attached directly to an external heatsink. The thermal pad must be soldered directly to the printed circuit board (PCB). After soldering, the PCB can be used as a heatsink. In addition, through the use of thermal vias, the thermal pad can be attached directly to the appropriate copper plane shown in the electrical schematic for the device, or alternatively, can be attached to a special heatsink structure designed into the PCB. This design optimizes the heat transfer from the integrated circuit (IC).

For information on the Quad Flatpack No-Lead (QFN) package and its advantages, refer to Application Report, QFN/SON PCB Attachment, Texas Instruments Literature No. SLUA271. This document is available at www.ti.com.

The exposed thermal pad dimensions for this package are shown in the following illustration.



Bottom View

Exposed Thermal Pad Dimensions

4206353-3/P 03/14

NOTE: All linear dimensions are in millimeters

RGY (R-PVQFN-N16)

PLASTIC QUAD FLATPACK NO-LEAD



- NOTES:
- A. All linear dimensions are in millimeters.
 - B. This drawing is subject to change without notice.
 - C. Publication IPC-7351 is recommended for alternate designs.
 - D. This package is designed to be soldered to a thermal pad on the board. Refer to Application Note, Quad Flat-Pack QFN/SON PCB Attachment, Texas Instruments Literature No. SLUA271, and also the Product Data Sheets for specific thermal information, via requirements, and recommended board layout. These documents are available at www.ti.com <<http://www.ti.com>>.
 - E. Laser cutting apertures with trapezoidal walls and also rounding corners will offer better paste release. Customers should contact their board assembly site for stencil design recommendations. Refer to IPC 7525 for stencil design considerations.
 - F. Customers should contact their board fabrication site for minimum solder mask web tolerances between signal pads.

IMPORTANT NOTICE AND DISCLAIMER

TI PROVIDES TECHNICAL AND RELIABILITY DATA (INCLUDING DATA SHEETS), DESIGN RESOURCES (INCLUDING REFERENCE DESIGNS), APPLICATION OR OTHER DESIGN ADVICE, WEB TOOLS, SAFETY INFORMATION, AND OTHER RESOURCES "AS IS" AND WITH ALL FAULTS, AND DISCLAIMS ALL WARRANTIES, EXPRESS AND IMPLIED, INCLUDING WITHOUT LIMITATION ANY IMPLIED WARRANTIES OF MERCHANTABILITY, FITNESS FOR A PARTICULAR PURPOSE OR NON-INFRINGEMENT OF THIRD PARTY INTELLECTUAL PROPERTY RIGHTS.

These resources are intended for skilled developers designing with TI products. You are solely responsible for (1) selecting the appropriate TI products for your application, (2) designing, validating and testing your application, and (3) ensuring your application meets applicable standards, and any other safety, security, regulatory or other requirements.

These resources are subject to change without notice. TI grants you permission to use these resources only for development of an application that uses the TI products described in the resource. Other reproduction and display of these resources is prohibited. No license is granted to any other TI intellectual property right or to any third party intellectual property right. TI disclaims responsibility for, and you will fully indemnify TI and its representatives against, any claims, damages, costs, losses, and liabilities arising out of your use of these resources.

TI's products are provided subject to [TI's Terms of Sale](#) or other applicable terms available either on ti.com or provided in conjunction with such TI products. TI's provision of these resources does not expand or otherwise alter TI's applicable warranties or warranty disclaimers for TI products.

TI objects to and rejects any additional or different terms you may have proposed.

Mailing Address: Texas Instruments, Post Office Box 655303, Dallas, Texas 75265
Copyright © 2022, Texas Instruments Incorporated