

具有 64 字节 FIFO 的 TL16C752CI-Q1 双路 UART

1 特性

- 符合汽车级 Q100 标准
- SC16C752B 和 XR16M752 引脚兼容其他增强功能
- 支持 1.8V、2.5V、3.3V 或 5V 电源
- 运行温度范围为 -40°C 至 $+105^{\circ}\text{C}$
- 支持高达：
 - 48MHz 振荡器输入时钟 (3Mbps)，面向 5V 工作电压
 - 32MHz 振荡器输入时钟 (2Mbps)，面向 3.3V 工作电压
 - 24MHz 输入时钟 (1.5Mbps)，面向 2.5V 工作电压
 - 16MHz 输入时钟 (1Mbps)，面向 1.8V 工作电压
- 64 字节发送/接收 FIFO
- 可通过软件选择的波特率发生器
- 用于直接存储器存取 (DMA)、中断生成以及软件或硬件流控制的可编程且可选的发送和接收 FIFO 触发电平
- 软件/硬件流控制
 - 可编程的 Xon 和 Xoff 字符，可选“Xon 任意” (Xon Any) 字符
 - 可编程的自动请求发送 (RTS) 和自动清除发送 (CTS) 调制解调器控制功能 (CTS、RTS、数据准备就绪 (DSR)、数据终端就绪 (DTR)、振铃指示器 (RI) 和载波检测 (CD))
- DMA 信号传输功能，用于 PN 封装中的数据发送与接收
- RS-485 模式支持
- 红外数据协会 (IrDA) 功能
- 可编程休眠模式
- 可编程串行接口特性
 - 5、6、7 或 8 位字符，可生成 1、1.5 或 2 个停止位
 - 偶校验、奇校验或无奇偶校验位生成与检测
- 错误启动位和线路中断检测
- 内部测试和环回功能

2 应用

- 全球定位系统 (GPS) 系统
- 以太网路由器
- 红外线收发器
- 家用应用
- 便携式应用
- 工厂自动化和过程控制

3 说明

TL16C752CI-Q1 是一款双路通用异步收发器 (UART)，具有 64 字节先入先出 (FIFO) 以及自动硬件和软件流控制功能，数据传输速率最高可达 3Mbps。该器件具备增强功能的磁场感测解决方案。该器件具有一个传输字符控制寄存器 (TCR)，可存储接收到的 FIFO 阈值电平，用于在硬件和软件流控制过程中启动或停止传输。

器件信息⁽¹⁾

器件型号	封装	封装尺寸 (标称值)
TL16C752CI-Q1	TQFP (48)	7.00mm × 7.00mm
	超薄四方扁平无引线 (VQFN) (32)	5.00mm × 5.00mm

(1) 要了解所有可用封装，请参见数据表末尾的可订购产品附录。

框图

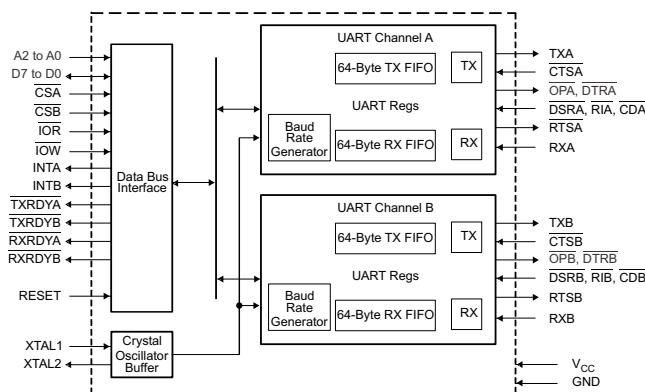

目录

1	特性	1	8.3	Feature Description.....	18
2	应用	1	8.4	Device Functional Modes.....	28
3	说明	1	8.5	Register Maps	30
4	修订历史记录	2	9	Application and Implementation	46
5	说明 (续)	2	9.1	Application Information.....	46
6	Pin Configuration and Functions	3	9.2	Typical Application	46
7	Specifications.....	7	10	Power Supply Recommendations	48
7.1	Absolute Maximum Ratings	7	11	Layout.....	49
7.2	ESD Ratings.....	7	11.1	Layout Guidelines	49
7.3	Recommended Operating Conditions.....	8	11.2	Layout Example	50
7.4	Thermal Information	9	12	器件和文档支持	51
7.5	Electrical Characteristics.....	9	12.1	社区资源.....	51
7.6	Timing Requirements	11	12.2	商标.....	51
7.7	Typical Characteristics	15	12.3	静电放电警告.....	51
8	Detailed Description	17	12.4	Glossary	51
8.1	Overview	17	13	机械、封装和可订购信息.....	51
8.2	Functional Block Diagram	17			

4 修订历史记录

注：之前版本的页码可能与当前版本有所不同。

Changes from Original (October 2015) to Revision A

Page

• 已更改 将运行温度范围从 -40°C 至 85°C 更改为 -40°C 至 $+105^{\circ}\text{C}$	1
• 将器件信息表中的“封装尺寸”列由 3.67mm x 3.67mm 更改为 7.00mm x 7.00mm	1
• Changed the CDM value from ± 500 to ± 1000	7

5 说明 (续)

凭借 FIFO RDY 寄存器，软件只需执行单次访问即可获得两个端口的 TXRDY 或 RXRDY 状态。片上状态寄存器可为用户提供错误指示、运行状态以及调制解调器接口控制。可根据用户要求定制系统中断。内部环回功能支持板上诊断。TL16C752CI-Q1 整合了两个 UART 的功能，每个 UART 具备各自的寄存器集和 FIFO。两个 UART 只共享数据总线接口和时钟源，除此之外都是独立运行的。UART 功能也称作异步通信元件 (ACE)，这两个术语可互换使用。本文档主要介绍每个 ACE 的行为，并让读者了解到 TL16C752CI-Q1 器件中整合了这两个 ACE。

6 Pin Configuration and Functions

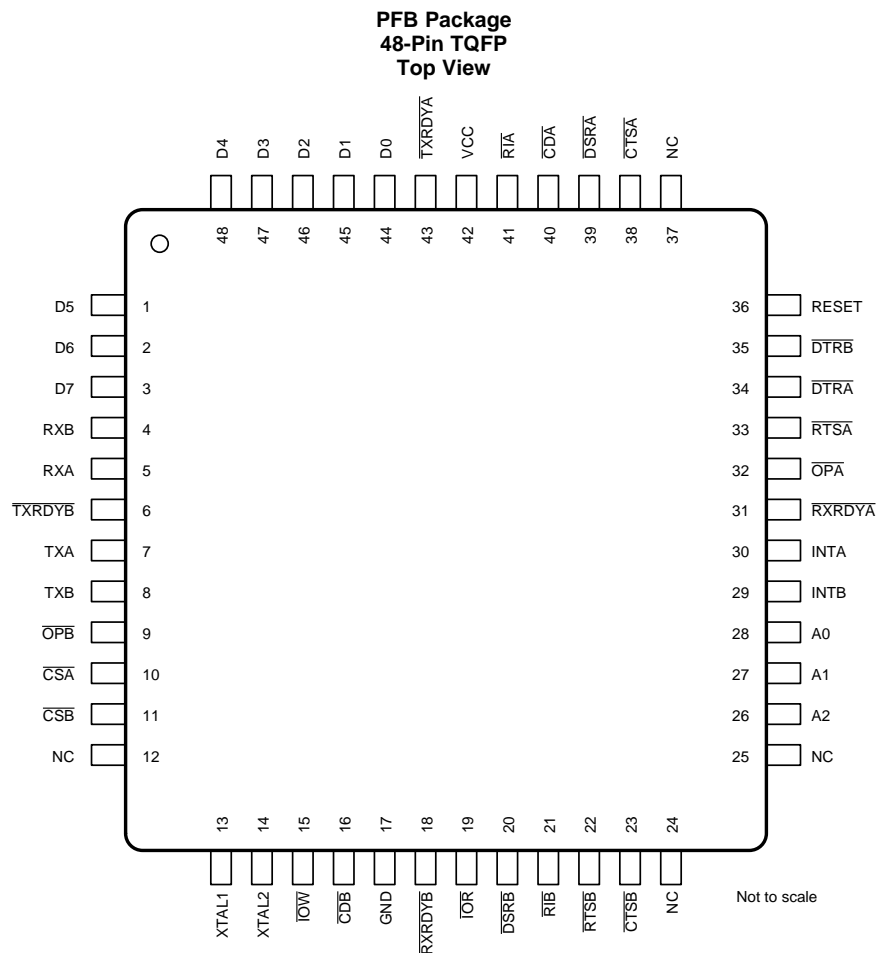

NC – No internal connection

Pin Functions

PIN		TYPE	DESCRIPTION
NAME	NO.		
A0	28	I	Address bit 0 select. Internal registers address selection. Refer to Figure 26 for register address map.
A1	27	I	Address bit 1 select. Internal registers address selection. Refer to Figure 26 for register address map.
A2	26	I	Address bit 2 select. Internal registers address selection. Refer to Figure 26 for register address map.
$\overline{\text{CDA}}$	40	I	Carrier detect (active low). These inputs are associated with individual UART channels A and B. A low on these pins indicates that a carrier has been detected by the modem for that channel.
$\overline{\text{CDB}}$	16		
$\overline{\text{CSA}}$	10	I	Chip select A and B (active low). These pins enable data transfers between the user CPU and the TL16C752CI-Q1 for the channel or channels addressed. Individual UART sections (A and B) are addressed by providing a low on the respective CSA and CSB pin.
$\overline{\text{CSB}}$	11		
$\overline{\text{CTSA}}$	38	I	Clear to send (active low). These inputs are associated with individual UART channels A and B. A low on the $\overline{\text{CTS}}$ pins indicates the modem or data set is ready to accept transmit data from the TL16C752CI-Q1 device. Status can be checked by reading MSR[4]. These pins only affect the transmit and receive operations when auto $\overline{\text{CTS}}$ function is enabled through the enhanced feature register (EFR[7]), for hardware flow control operation.
$\overline{\text{CTSB}}$	23		
D0	44	I/O	Data bus (bidirectional). These pins are the 8-bit, 3-state data bus for transferring information to or from the controlling CPU. D0 is the least significant bit and the first data bit in a transmit or receive serial data stream.
D1	45		
D2	46		
D3	47		
D4	48		
D5	1		
D6	2		
D7	3		
$\overline{\text{DSRA}}$	39	I	Data set ready (active low). These inputs are associated with individual UART channels A through B. A low on these pins indicates the modem or data set is powered on and is ready for data exchange with the UART.
$\overline{\text{DSRB}}$	20		
$\overline{\text{DTRA}}$	34	O	Data terminal ready (active low). These outputs are associated with individual UART channels A through B. A low on these pins indicates that the TL16C752CI-Q1 is powered on and ready. These pins can be controlled through the modem control register. Writing a 1 to MCR[0] sets the DTR output to low, enabling the modem. The output of these pins is high after writing a 0 to MCR[0], or after a reset. These pins can also be used in the RS-485 mode to control an external RS-485 driver or transceiver.
$\overline{\text{DTRB}}$	35		
GND	17	Pwr	Power signal and power ground
INTA	30	O	Interrupt A and B (active high). These pins provide individual channel interrupts, INTA-B. INTA-B are enabled when MCR[3] is set to a 1, interrupts are enabled in the interrupt enable register (IER) and when an interrupt condition exists. Interrupt conditions include: receiver errors, available receiver buffer data, transmit buffer empty, or when a modem status flag is detected. INTA-B are in the high-impedance state after reset.
INTB	29		
$\overline{\text{IOR}}$	19	I	Read input (active low strobe). A valid low level on $\overline{\text{IOR}}$ loads the contents of an internal register defined by address bits A0 through A2 onto the TL16C752CI-Q1 device data bus (D0 through D7) for access by an external CPU.
$\overline{\text{IOW}}$	15	I	Write input (active low strobe). A valid low level on $\overline{\text{IOW}}$ transfers the contents of the data bus (D0 through D7) from the external CPU to an internal register that is defined by address bits A0 through A2.
NC	12	—	No internal connection
NC	24		
NC	25		
NC	37		
$\overline{\text{OPA}}$	32	O	User defined outputs. This function is associated with individual channels A and B. The state of these pins is defined by the user through the software settings of the MCR register, bit 3. INTA-B are set to active mode and $\overline{\text{OP}}$ to a logic 0 when the MCR-3 is set to a logic 1. INTA-B are set to the 3-state mode and $\overline{\text{OP}}$ to a logic 1 when MCR-3 is set to a logic 0. See bit 3, modem control register (MCR bit 3). The output of these two pins is high after reset.
$\overline{\text{OPB}}$	9		
RESET	36	I	Reset. RESET resets the internal registers and all the outputs. The UART transmitter output and the receiver input are disabled during reset time. For initialization details, see TL16C752CI-Q1 device external reset conditions. RESET is an active high input.
$\overline{\text{RIA}}$	41	I	Ring indicator (active low). These inputs are associated with individual UART channels A and B. A logic low on these pins indicates the modem has received a ringing signal from the telephone line. A low-to-high transition on these input pins generates a modem status interrupt, if enabled. The state of these inputs is reflected in the modem status register (MSR).
$\overline{\text{RIB}}$	21		
$\overline{\text{RTSA}}$	33	O	Request to send (active low). These outputs are associated with individual UART channels A and B. A low on the RTS pins indicates the transmitter has data ready and waiting to send. Writing a 1 in the modem control register (MCR[1]) sets these pins to low, indicating data is available. After a reset, these pins are set to 1. These pins only affect the transmit and receive operation when auto-RTS function is enabled through the enhanced feature register (EFR[6]), for hardware flow control operation.
$\overline{\text{RTSB}}$	22		
RXA	5	I	Receive data input. These inputs are associated with individual serial channel data to the TL16C752CI-Q1 device. During the local loopback mode, these RX input pins are disabled and TX data is internally connected to the UART RX input internally. During normal mode, RXn should be held high when no data is being received. These inputs also can be used in IrDA mode. For more information, see IrDA Overview .
RXB	4		

Pin Functions (continued)

PIN		TYPE	DESCRIPTION
NAME	NO.		
$\overline{\text{RXRDYA}}$	31	O	Receive ready (active low). $\overline{\text{RXRDYA}}$ and $\overline{\text{RXRDYB}}$ go low when the trigger level has been reached or a timeout interrupt occurs. They go high when the RX FIFO is empty or there is an error in RX FIFO.
$\overline{\text{RXRDYB}}$	18		
TXA	7	O	Transmit data. These outputs are associated with individual serial transmit channel data from the TL16C752CI-Q1 device. During the local loopback mode, the TX input pin is disabled and TX data is internally connected to the UART RX input.
TXB	8		
$\overline{\text{TXRDYA}}$	43	O	Transmit ready (active low). $\overline{\text{TXRDYA}}$ and $\overline{\text{TXRDYB}}$ go low when there are a trigger level number of spares available. They go high when the TX buffer is full.
$\overline{\text{TXRDYB}}$	6		
V _{CC}	42	PWR	Power supply inputs
XTAL1	13	I	Crystal or external clock input. XTAL1 functions as a crystal input or as an external clock input. A crystal can be connected between XTAL1 and XTAL2 to form an internal oscillator circuit. Alternatively, an external clock can be connected to XTAL1 to provide custom data rates.
XTAL2	14	O	Output of the crystal oscillator or buffered clock. See also XTAL1. XTAL2 is used as a crystal oscillator output or buffered clock output.

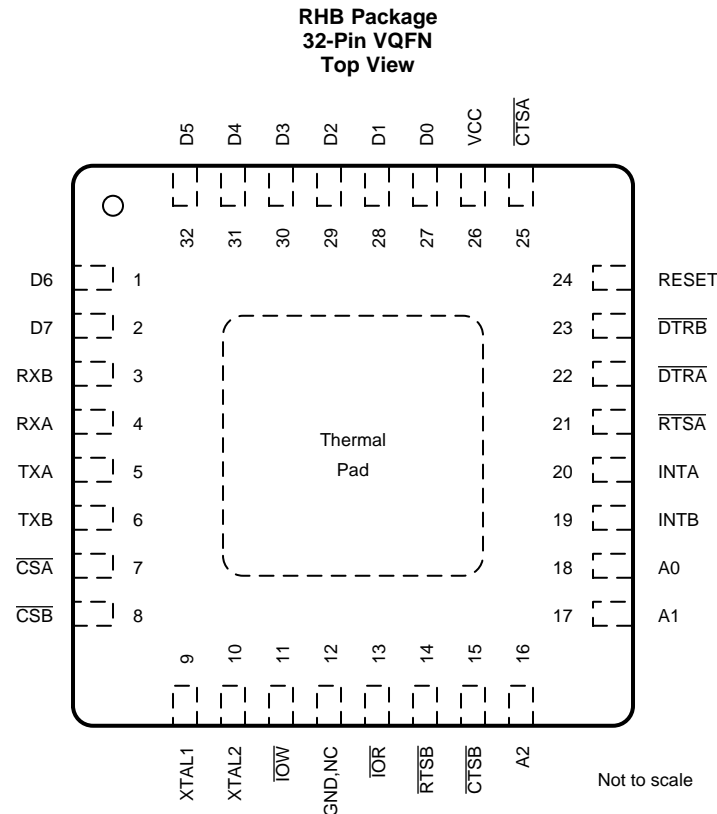

The 32-pin RHB package does not provide access to \overline{DSRA} , \overline{DSRB} , \overline{RIA} , \overline{RIB} , \overline{CDA} , and \overline{CDB} inputs or \overline{OPA} , \overline{OPB} , \overline{RXRDYA} , \overline{RXRDYB} , and \overline{TXRDYA} outputs.

Pin Functions

PIN		TYPE	DESCRIPTION
NAME	NO.		
A0	18	I	Address bit 0 select. Internal registers address selection. Refer to Figure 26 for register address map.
A1	17	I	Address bit 1 select. Internal registers address selection. Refer to Figure 26 for register address map.
A2	16	I	Address bit 2 select. Internal registers address selection. Refer to Figure 26 for register address map.
\overline{CSA}	7	I	Chip select A and B (active low). These pins enable data transfers between the user CPU and the TL16C752CI-Q1 for the channel or channels addressed. Individual UART sections (A and B) are addressed by providing a low on the respective CSA and CSB pin.
\overline{CSB}	8		
\overline{CTSA}	25	I	Clear to send (active low). These inputs are associated with individual UART channels A and B. A low on the \overline{CTS} pins indicates the modem or data set is ready to accept transmit data from the TL16C752CI-Q1 device. Status can be checked by reading MSR[4]. These pins only affect the transmit and receive operations when auto CTS function is enabled through the enhanced feature register (EFR[7]), for hardware flow control operation.
\overline{CTSB}	15		
D0	27	I/O	Data bus (bidirectional). These pins are the 8-bit, 3-state data bus for transferring information to or from the controlling CPU. D0 is the least significant bit and the first data bit in a transmit or receive serial data stream.
D1	28		
D2	29		
D3	30		
D4	31		
D5	32		
D6	1		
\overline{DTRA}	22	O	Data terminal ready (active low). These outputs are associated with individual UART channels A through B. A low on these pins indicates that the TL16C752CI-Q1 is powered on and ready. These pins can be controlled through the modem control register. Writing a 1 to MCR[0] sets the \overline{DTR} output to low, enabling the modem. The output of these pins is high after writing a 0 to MCR[0], or after a reset. These pins can also be used in the RS-485 mode to control an external RS-485 driver or transceiver.
\overline{DTRB}	23		
GND	12	Pwr	Power signal and power ground

Pin Functions (continued)

PIN		TYPE	DESCRIPTION
NAME	NO.		
INTA	20	O	Interrupt A and B (active high). These pins provide individual channel interrupts, INTA-B. INTA-B are enabled when MCR[3] is set to a 1, interrupts are enabled in the interrupt enable register (IER) and when an interrupt condition exists. Interrupt conditions include: receiver errors, available receiver buffer data, transmit buffer empty, or when a modem status flag is detected. INTA-B are in the high-impedance state after reset.
INTB	19		
$\overline{\text{IOR}}$	13	I	Read input (active low strobe). A valid low level on $\overline{\text{IOR}}$ loads the contents of an internal register defined by address bits A0 through A2 onto the TL16C752CI-Q1 device data bus (D0 through D7) for access by an external CPU.
$\overline{\text{IOW}}$	11	I	Write input (active low strobe). A valid low level on $\overline{\text{IOW}}$ transfers the contents of the data bus (D0 through D7) from the external CPU to an internal register that is defined by address bits A0 through A2.
NC	12	—	No internal connection
RESET	24	I	Reset. RESET resets the internal registers and all the outputs. The UART transmitter output and the receiver input are disabled during reset time. For initialization details, see TL16C752CI-Q1 device external reset conditions. RESET is an active high input.
$\overline{\text{RTSA}}$	21	O	Request to send (active low). These outputs are associated with individual UART channels A and B. A low on the RTS pins indicates the transmitter has data ready and waiting to send. Writing a 1 in the modem control register (MCR[1]) sets these pins to low, indicating data is available. After a reset, these pins are set to 1. These pins only affect the transmit and receive operation when auto-RTS function is enabled through the enhanced feature register (EFR[6]), for hardware flow control operation.
$\overline{\text{RTSB}}$	14		
RXA	4	I	Receive data input. These inputs are associated with individual serial channel data to the TL16C752CI-Q1 device. During the local loopback mode, these RX input pins are disabled and TX data is internally connected to the UART RX input internally. During normal mode, RXn should be held high when no data is being received. These inputs also can be used in IrDA mode. For more information, see IrDA Overview .
RXB	3		
TXA	5	O	Transmit data. These outputs are associated with individual serial transmit channel data from the TL16C752CI-Q1 device. During the local loopback mode, the TX input pin is disabled and TX data is internally connected to the UART RX input.
TXB	6		
V _{CC}	26	PWR	Power supply inputs
XTAL1	9	I	Crystal or external clock input. XTAL1 functions as a crystal input or as an external clock input. A crystal can be connected between XTAL1 and XTAL2 to form an internal oscillator circuit. Alternatively, an external clock can be connected to XTAL1 to provide custom data rates.
XTAL2	10	O	Output of the crystal oscillator or buffered clock. See also XTAL1. XTAL2 is used as a crystal oscillator output or buffered clock output.

7 Specifications

7.1 Absolute Maximum Ratings

over operating free-air temperature range (unless otherwise noted)⁽¹⁾

	MIN	MAX	UNIT
V _{CC} Supply voltage	-0.5	6	V
V _I Input voltage	-0.5	V _{CC} + 0.5	V
V _O Output voltage	-0.5	V _{CC} + 0.5	V
T _A Operating free-air temperature	-40	105	°C
T _{stg} Storage temperature	-65	150	°C

- (1) Stresses beyond those listed under *Absolute Maximum Ratings* may cause permanent damage to the device. These are stress ratings only and functional operation of the device at these or any other conditions beyond those indicated under *Recommended Operating Conditions* is not implied. Exposure to absolute-maximum-rated conditions for extended periods may affect device reliability.

7.2 ESD Ratings

	VALUE	UNIT
V _(ESD) Electrostatic discharge	Human-body model (HBM), per AEC Q100-002 ⁽¹⁾	±2000
	Charged-device model (CDM), per AEC Q100-011	±1000

- (1) AEC Q100-002 indicates that HBM stressing shall be in accordance with the ANSI/ESDA/JEDEC JS-001 specification.

7.3 Recommended Operating Conditions

over operating free-air temperature range (unless otherwise noted)

		MIN	NOM	MAX	UNIT
V_{CC} = 1.8 V ±10%					
V _{CC}	Supply voltage	1.62	1.8	1.98	V
V _I	Input voltage	-0.3		0.9 × V _{CC}	V
V _{IH}	High-level input voltage	1.4			V
V _{IL}	Low-level input voltage			0.4	V
V _O	Output voltage	0		V _{CC}	V
I _{OH}	High-level output current	All outputs		-0.5	mA
I _{OL}	Low-level output current	All outputs		1	mA
	Oscillator/clock speed			16	MHz
V_{CC} = 2.5 V ±10%					
V _{CC}	Supply voltage	2.25	2.5	2.75	V
V _I	Input voltage	-0.3		0.9 × V _{CC}	V
V _{IH}	High-level input voltage	1.8			V
V _{IL}	Low-level input voltage			0.6	V
V _O	Output voltage	0		V _{CC}	V
I _{OH}	High-level output current	All outputs		-1	mA
I _{OL}	Low-level output current	All outputs		2	mA
	Oscillator/clock speed			24	MHz
V_{CC} = 3.3 V ±10%					
V _{CC}	Supply voltage	3	3.3	3.6	V
V _I	Input voltage	-0.3		V _{CC}	V
V _{IH}	High-level input voltage	0.7 × V _{CC}			V
V _{IL}	Low-level input voltage			0.8	V
V _O	Output voltage	0		V _{CC}	V
I _{OH}	High-level output current	All outputs		-1.8	mA
I _{OL}	Low-level output current	All outputs		3.2	mA
	Oscillator or clock speed			32	MHz
V_{CC} = 5 V ±10%					
V _{CC}	Supply voltage	4.5	5	5.5	V
V _I	Input voltage	-0.3		V _{CC}	V
V _{IH}	High-level input voltage	Except XTAL1	2		V
		XTAL1	0.7 × V _{CC}		
V _{IL}	Low-level input voltage	Except XTAL1	0.8		V
		XTAL1	0.3 × V _{CC}		
V _O	Output voltage	0		V _{CC}	V
I _{OH}	High-level output current	All outputs		-4	mA
I _{OL}	Low-level output current	All outputs		4	mA
	Oscillator or clock speed			48	MHz

7.4 Thermal Information

THERMAL METRIC ⁽¹⁾		TL16C752CI-Q1	
		PFB (TQFP)	
		48 PINS	
Symbol	Description	Value	UNIT
R _{θJA}	Junction-to-ambient thermal resistance	61	°C/W
R _{θJC(top)}	Junction-to-case (top) thermal resistance	17.3	°C/W
R _{θJC(bot)}	Junction-to-case (bottom) thermal resistance	N/A	°C/W

(1) For more information about traditional and new thermal metrics, see the [Semiconductor and IC Package Thermal Metrics](#) application report.

7.5 Electrical Characteristics

over operating free-air temperature range (unless otherwise noted)

PARAMETER		TEST CONDITIONS		MIN	TYP	MAX	UNIT
V_{CC} = 1.8 V							
V _{OH}	High-level output voltage	I _{OH} = -0.5 mA		1.3			V
V _{OL}	Low-level output voltage	I _{OL} = 1 mA				0.5	V
I _I	Input current	V _{CC} = 1.98 V, V _I = 0 to 1.98 V, V _{SS} = 0, All other terminals floating				10	μA
I _{OZ}	High-impedance state output current	V _{CC} = 1.98 V, V _O = 0 to 1.98 V, Chip selected in write mode or chip deselect	V _{SS} = 0,			±20	μA
I _{CC}	Supply current	V _{CC} = 1.98 V, DSR, CTS, and RI at 2 V, All other inputs at 0.4 V, No load on outputs,	T _A = 70°C, XTAL1 at 16 MHz, Baud rate = 1 Mbps			4.5	mA
C _{I(CLK)}	Clock input capacitance	V _{CC} = 0, f = 1 MHz, All other terminals grounded	V _{SS} = 0, T _A = 25°C,		5	7	pF
C _{O(CLK)}	Clock output capacitance	V _{CC} = 0, f = 1 MHz, All other terminals grounded	V _{SS} = 0, T _A = 25°C,		5	7	pF
C _I	Input capacitance	V _{CC} = 0, f = 1 MHz, All other terminals grounded	V _{SS} = 0, T _A = 25°C,		6	10	pF
C _O	Output capacitance	V _{CC} = 0, f = 1 MHz, All other terminals grounded	V _{SS} = 0, T _A = 25°C,		10	15	pF
V_{CC} = 2.5 V							
V _{OH}	High-level output voltage	I _{OH} = -1 mA		1.8			V
V _{OL}	Low-level output voltage	I _{OL} = 2 mA				0.5	V
I _I	Input current	V _{CC} = 2.75 V, V _I = 0 to 2.75 V, V _{SS} = 0, All other terminals floating				10	μA
I _{OZ}	High-impedance state output current	V _{CC} = 2.75 V, V _O = 0 to 2.75 V, Chip selected in write mode or chip deselect	V _{SS} = 0,			±20	μA
I _{CC}	Supply current	V _{CC} = 2.75 V, DCD, CTS, and RI at 2 V, All other inputs at 0.6 V, No load on outputs,	T _A = 70°C, XTAL1 at 24 MHz, Baud rate = 1.5 Mbps			9	mA
C _{I(CLK)}	Clock input capacitance	V _{CC} = 0, f = 1 MHz, All other terminals grounded	V _{SS} = 0, T _A = 25°C,		5	7	pF
C _{O(CLK)}	Clock output capacitance	V _{CC} = 0, f = 1 MHz, All other terminals grounded	V _{SS} = 0, T _A = 25°C,		5	7	pF

Electrical Characteristics (continued)

over operating free-air temperature range (unless otherwise noted)

PARAMETER		TEST CONDITIONS	MIN	TYP	MAX	UNIT
C_I	Input capacitance	$V_{CC} = 0$, $f = 1$ MHz, All other terminals grounded		6	10	pF
C_O	Output capacitance	$V_{CC} = 0$, $f = 1$ MHz, All other terminals grounded		10	15	pF
$V_{CC} = 3.3$ V						
V_{OH}	High-level output voltage	$I_{OH} = -1.8$ mA	2.4			V
V_{OL}	Low-level output voltage	$I_{OL} = 3.2$ mA			0.5	V
I_I	Input current	$V_{CC} = 3.6$ V, $V_I = 0$ to 3.6 V,			10	μ A
I_{OZ}	High-impedance state output current	$V_{CC} = 3.6$ V, $V_O = 0$ to 3.6 V, Chip selected in write mode or chip deselect			± 20	μ A
I_{CC}	Supply current	$V_{CC} = 3.6$ V, \overline{DSR} , \overline{CTS} , and \overline{RI} at 2 V, All other inputs at 0.8 V, No load on outputs,			16	mA
$C_{I(CLK)}$	Clock input capacitance	$V_{CC} = 0$, $f = 1$ MHz, All other terminals grounded		5	7	pF
$C_{O(CLK)}$	Clock output capacitance	$V_{CC} = 0$, $f = 1$ MHz, All other terminals grounded		5	7	pF
C_I	Input capacitance	$V_{CC} = 0$, $f = 1$ MHz, All other terminals grounded		6	10	pF
C_O	Output capacitance	$V_{CC} = 0$, $f = 1$ MHz, All other terminals grounded		10	15	pF
$V_{CC} = 5$ V						
V_{OH}	High-level output voltage	$I_{OH} = -4$ mA	4			V
V_{OL}	Low-level output voltage	$I_{OL} = 4$ mA for V_{OL}			0.5	V
I_I	Input current	$V_{CC} = 5.5$ V, $V_I = 0$ to 5.5 V,			10	μ A
I_{OZ}	High-impedance state output current	$V_{CC} = 5.5$ V, $V_O = 0$ to 5.5 V, Chip selected in write mode or chip deselect			± 20	μ A
I_{CC}	Supply current	$V_{CC} = 5.5$ V, \overline{DSR} , \overline{CTS} , and \overline{RI} at 2 V, All other inputs at 0.8 V, No load on outputs,			40	mA
$C_{I(CLK)}$	Clock input capacitance	$V_{CC} = 0$, $f = 1$ MHz, All other terminals grounded		5	7	pF
$C_{O(CLK)}$	Clock output capacitance	$V_{CC} = 0$, $f = 1$ MHz, All other terminals grounded		5	7	pF
C_I	Input capacitance	$V_{CC} = 0$, $f = 1$ MHz, All other terminals grounded		6	10	pF
C_O	Output capacitance	$V_{CC} = 0$, $f = 1$ MHz, All other terminals grounded		10	15	pF

7.6 Timing Requirements

$T_A = 0^\circ\text{C}$ to 70°C , $V_{CC} = 1.8\text{ V}$ to $5\text{ V} \pm 10\%$ (unless otherwise noted)

		LIMITS								UNIT
		1.8 V		2.5 V		3.3 V		5 V		
		MIN	MAX	MIN	MAX	MIN	MAX	MIN	MAX	
t_{RESET}	Reset pulse width	200		200		200		200		ns
C_P	CP clock period	63		42		32		20		ns
t_{3w}	Oscillator or clock speed		16		24		32		48	MHz
t_{6s}	Address setup time	20		15		10		5		ns
t_{6h}	Address hold time			15		10		7		ns
t_{7w}	IOR strobe width			85		70		50		ns
t_{9d}	Read cycle delay			85		70		60		ns
t_{12d}	Delay from IOR to data			65		50		35		ns
t_{12h}	Data disable time			35		25		20		ns
t_{13w}	IOW strobe width			85		70		50		ns
t_{15d}	Write cycle delay			85		70		60		ns
t_{16s}	Data setup time			40		30		20		ns
t_{16h}	Data hold time			35		25		15		ns
t_{17d}	Delay from IOW to output			60		40		30		ns
t_{18d}	Delay to set interrupt from MODEM input			70		55		45		ns
t_{19d}	Delay to reset interrupt from IOR			80		55		40		ns
t_{20d}	Delay from stop to set interrupt			1		1		1		baudrate
t_{21d}	Delay from IOR to reset interrupt			55		45		35		ns
t_{22d}	Delay from stop to interrupt			1		1		1		baudrate
t_{23d}	Delay from initial IOW reset to transmit start			8	24	8	24	8	24	baudrate
t_{24d}	Delay from IOW to reset interrupt			75		45		35		ns
t_{25d}	Delay from stop to set RXRDY			1		1		1		baudrate
t_{26d}	Delay from IOR to reset RXRDY			1		1		1		μs
t_{27d}	Delay from IOW to set TXRDY			70		60		50		ns
t_{28d}	Delay from start to reset TXRDY			16		16		16		baudrate

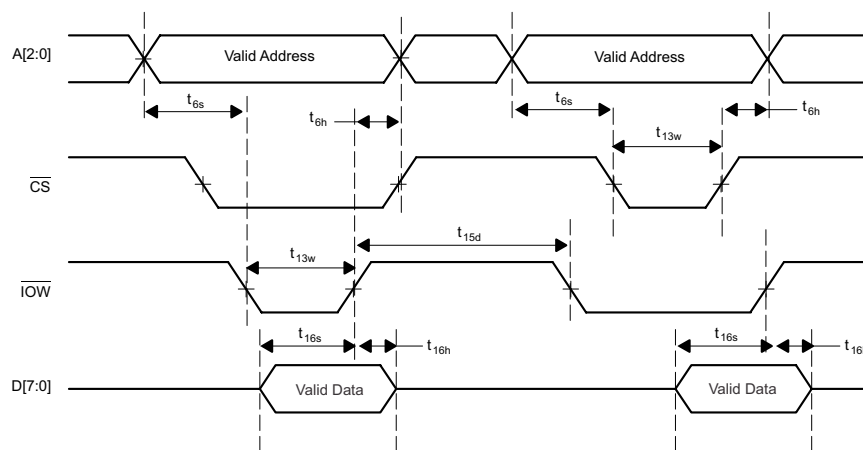
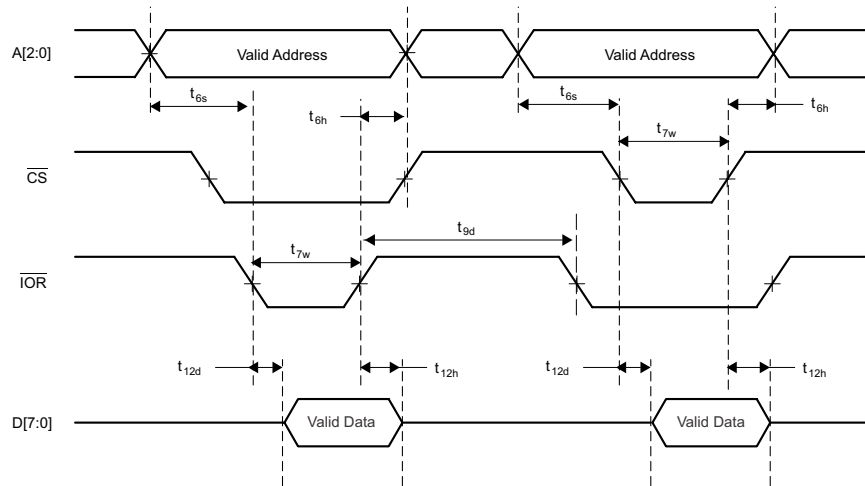
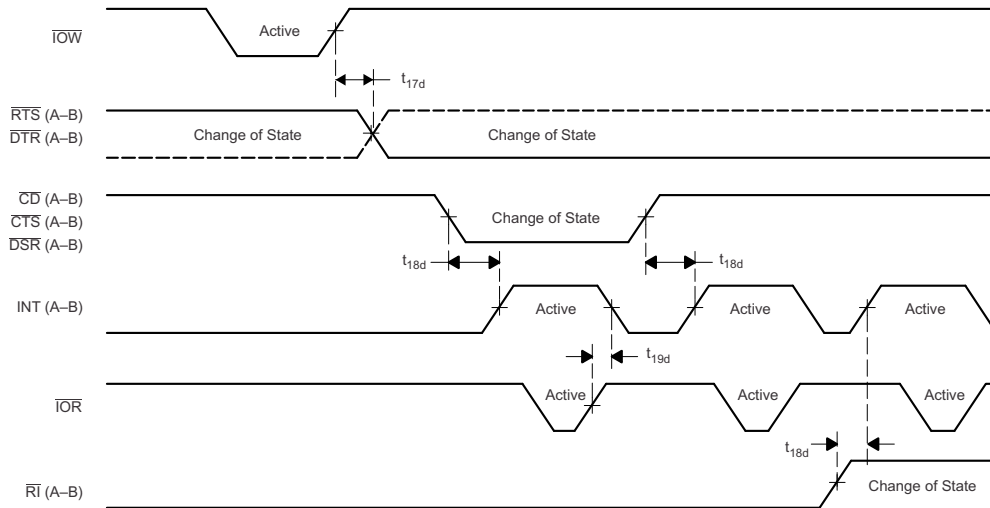

Figure 1. General Write Timing

Figure 2. General Read Timing

Figure 3. Modem or Output Timing

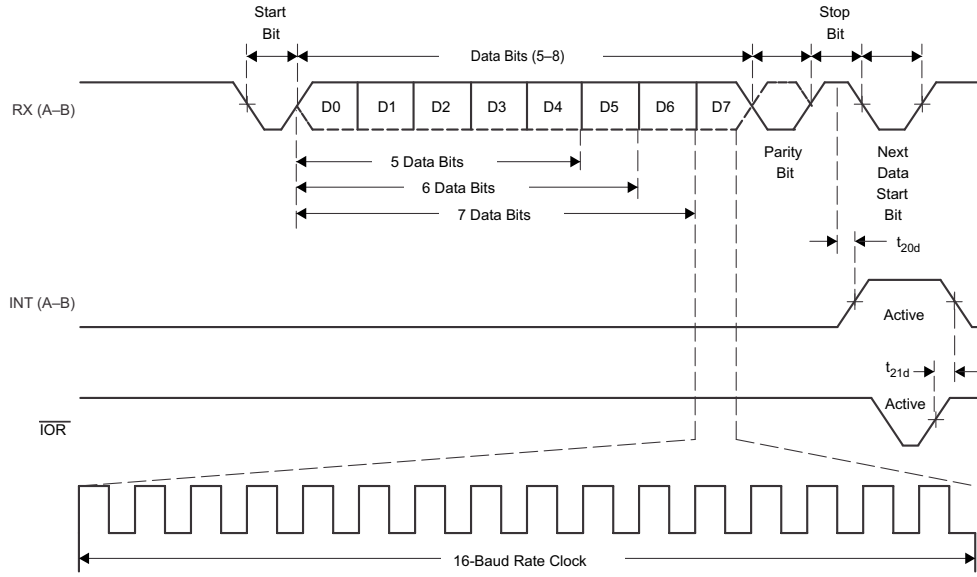

Figure 4. Receive Timing

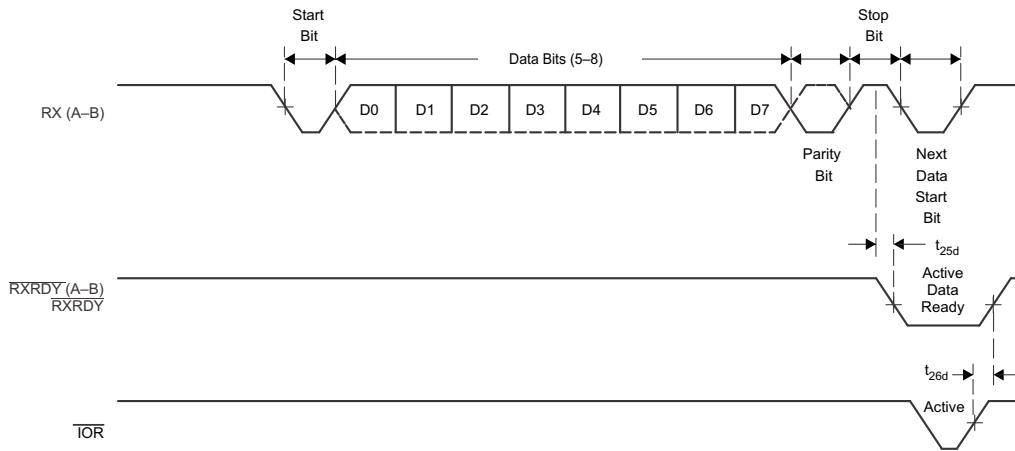

Figure 5. Receive Ready Timing in Non-FIFO Mode

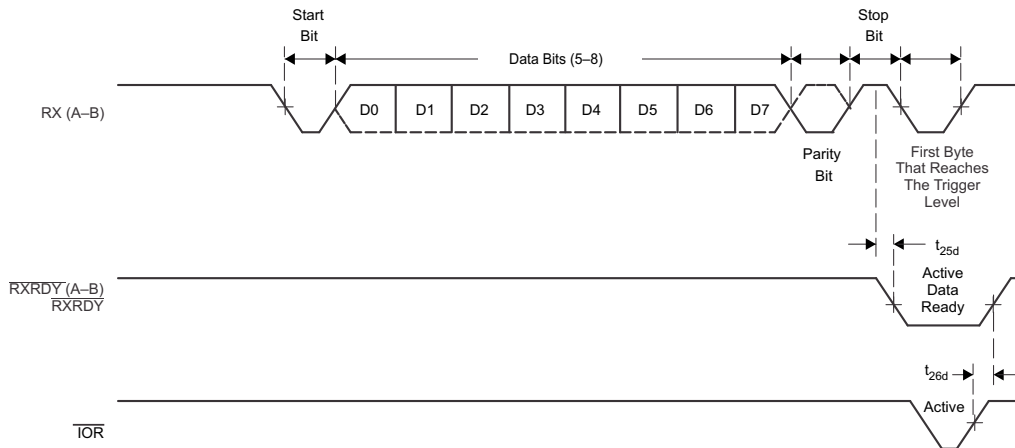

Figure 6. Receive Timing in FIFO Mode

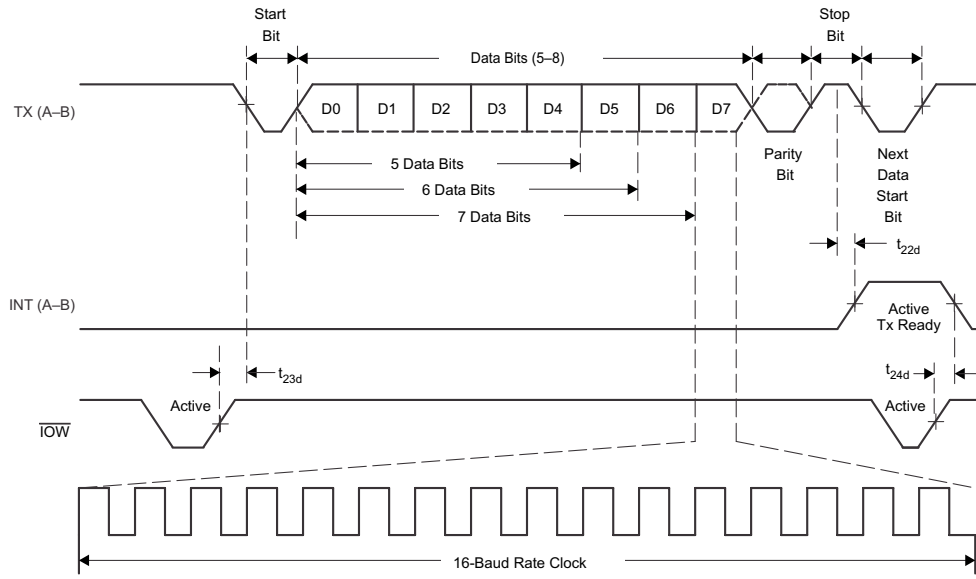

Figure 7. Transmit Timing

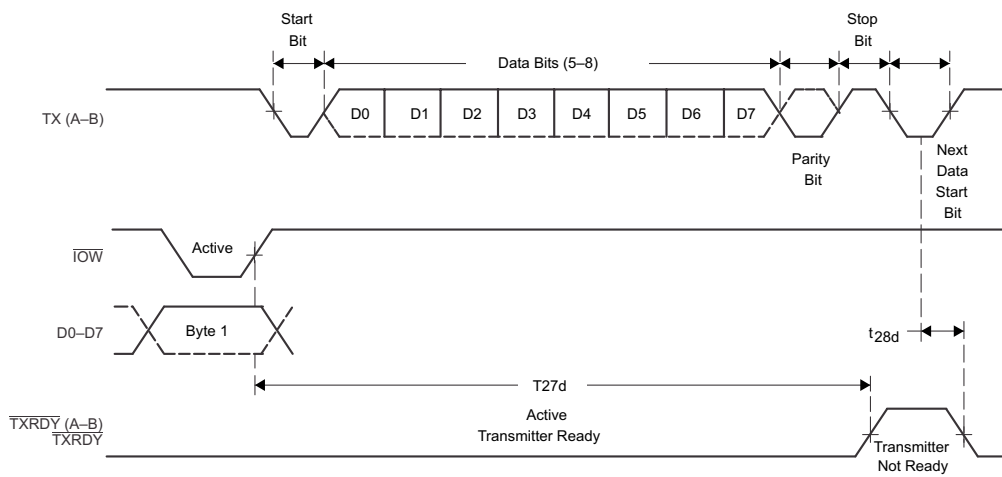

Figure 8. Transmit Ready Timing in Non-FIFO Mode

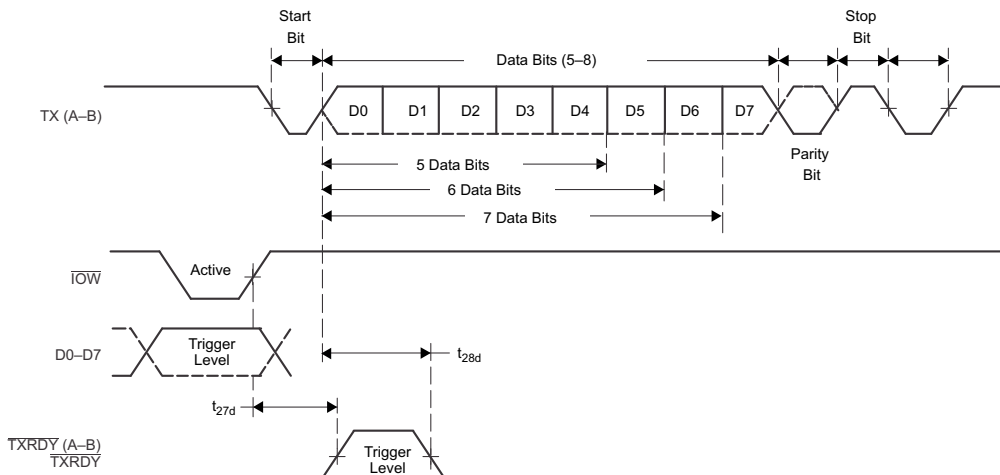

Figure 9. Transmit Timing in FIFO Mode

7.7 Typical Characteristics

all channels active, $T_A = 25^\circ\text{C}$, unless otherwise noted

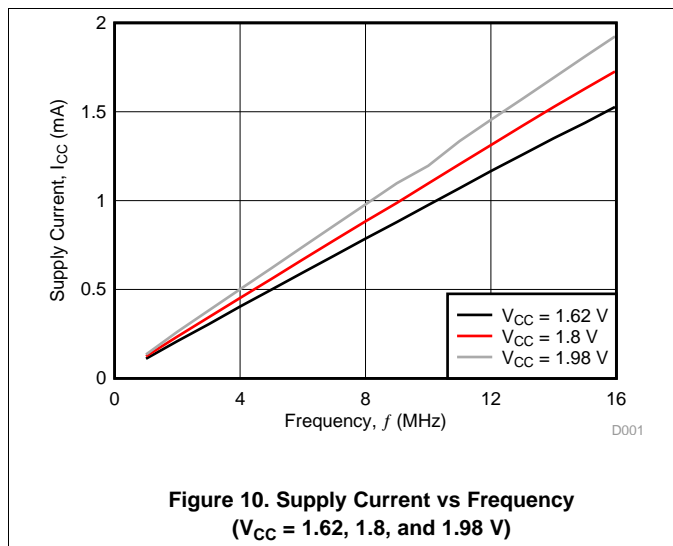

Figure 10. Supply Current vs Frequency ($V_{CC} = 1.62, 1.8, \text{ and } 1.98\text{ V}$)

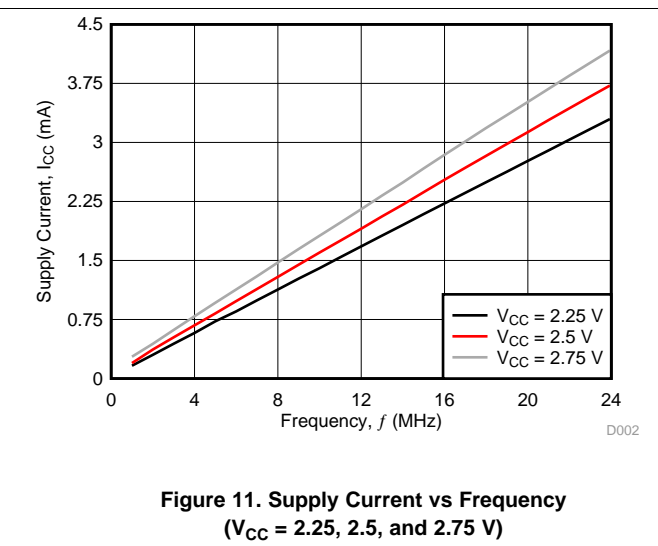
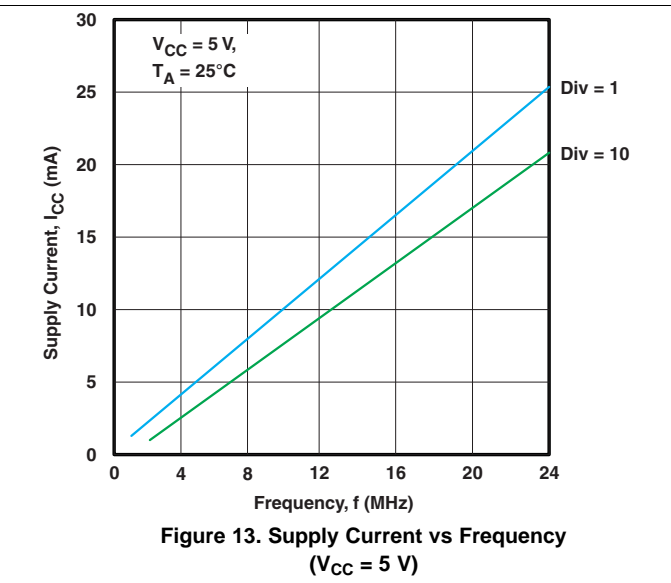
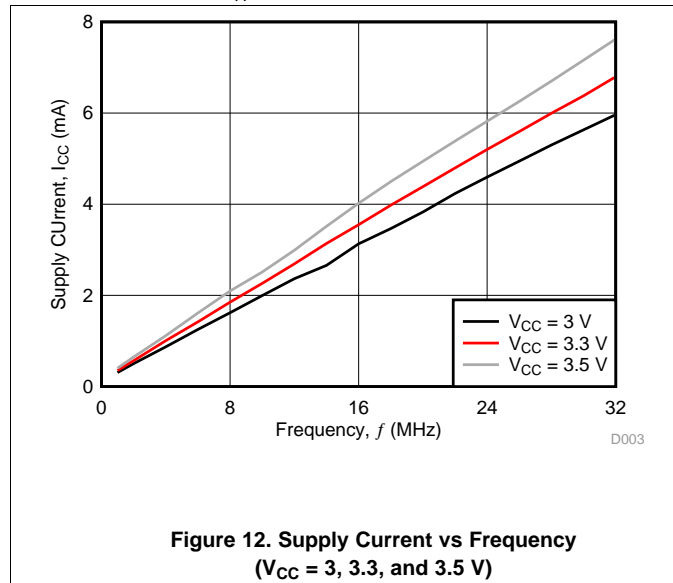

Figure 11. Supply Current vs Frequency ($V_{CC} = 2.25, 2.5, \text{ and } 2.75\text{ V}$)

Typical Characteristics (continued)

 all channels active, $T_A = 25^\circ\text{C}$, unless otherwise noted

8 Detailed Description

8.1 Overview

The TL16C752CI-Q1 UART is pin-compatible with the ST16C2550 UART in the PFB package. It provides more enhanced features. All additional features are provided through a special enhanced feature register.

The TL16C752CI-Q1 UART will perform serial-to-parallel conversion on data characters received from peripheral devices or modems and parallel-to-parallel conversion on data characters transmitted by the processor. The complete status of each channel of the TL16C752CI-Q1 UART can be read at any time during functional operation by the processor.

Each UART transmits data sent to it from the peripheral 8-bit bus on the TX signal and receives characters on the RX signal. Characters can be programmed to be 5, 6, 7, or 8 bits. The UART has a 64-byte receive FIFO and transmit FIFO and can be programmed to interrupt at different trigger levels. The UART generates its own desired baud rate based upon a programmable divisor and its input clock. It can transmit even, odd, or no parity and 1-, 1.5-, or 2-stop bits. The receiver can detect break, idle or framing errors, FIFO overflow, and parity errors. The transmitter can detect FIFO underflow. The UART also contains a software interface for modem control operations, and software flow control and hardware flow control capabilities.

8.2 Functional Block Diagram

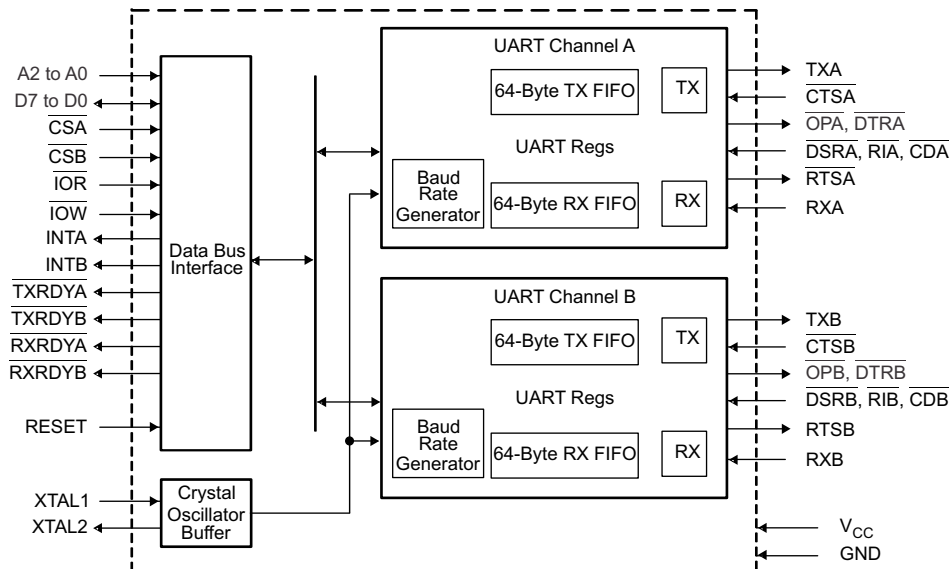
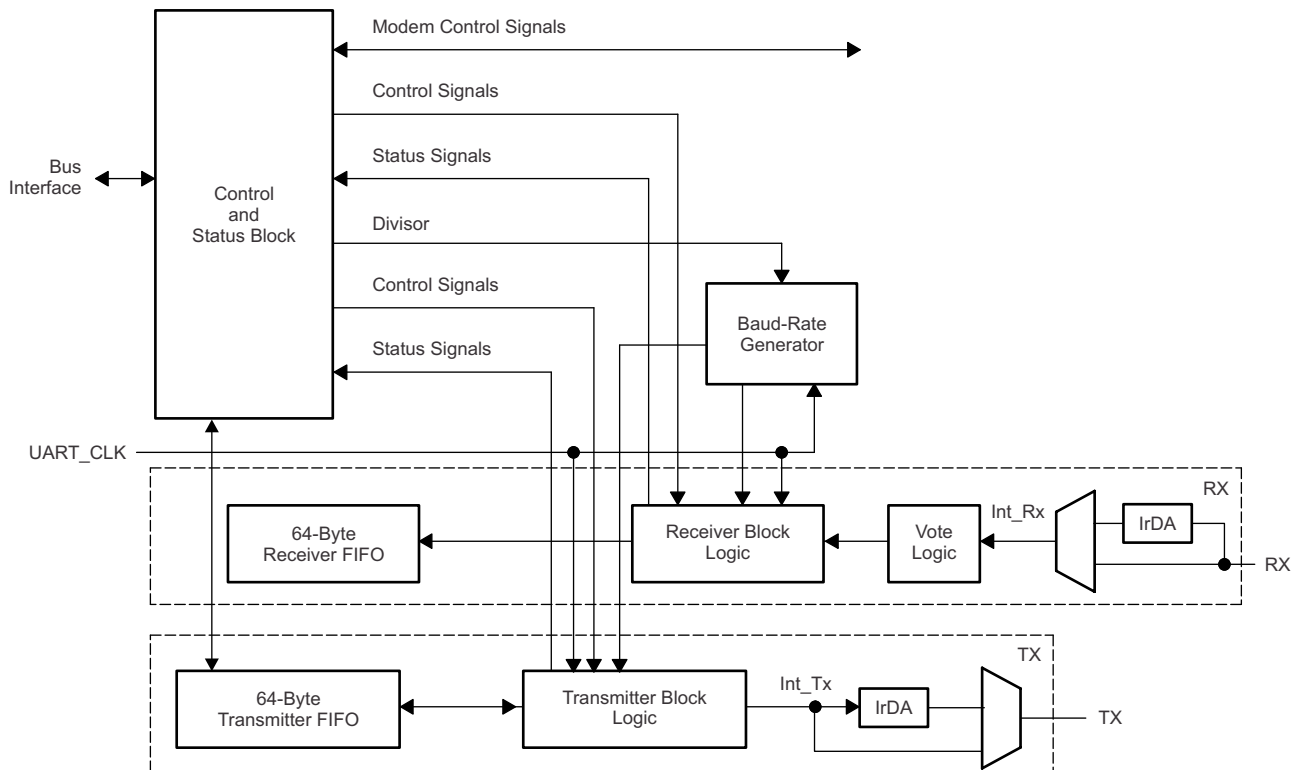

Figure 14. TL16C752CI-Q1 Functional Block Diagram

Functional Block Diagram (continued)

NOTE: The vote logic determines whether the RX data is a logic 1 or 0. It takes three samples of the RX line and uses a majority vote to determine the logic level received. The vote logic operates on all bits received.

Figure 15. TL16C752CI-Q1 Functional Block Diagram – Control Blocks

8.3 Feature Description

8.3.1 Functional Description

The TL16C752CI-Q1 UART can be placed in an alternate mode (FIFO mode) relieving the processor of excessive software overhead by buffering received and transmitted characters. Both the receiver and transmitter FIFOs can store up to 64 bytes (including three additional bits of error status per byte for the receiver FIFO) and have selectable or programmable trigger levels. Primary outputs $\overline{\text{RXRDY}}$ and $\overline{\text{TXRDY}}$ allow signaling of DMA transfers.

The TL16C752CI-Q1 UART has selectable hardware flow control and software flow control. Both schemes significantly reduce software overhead and increase system efficiency by automatically controlling serial data flow. Hardware flow control uses the $\overline{\text{RTS}}$ output and $\overline{\text{CTS}}$ input signals. Software flow control uses programmable Xon and Xoff characters.

The TL16C752CI-Q1 device includes a programmable baud rate generator that can divide the timing reference clock by a divisor between 1 and 65535. A bit (MCR7) can be used to invoke a prescaler (divide by 4) off the reference clock, prior to the baud rate generator input. The divide by 4 prescaler is selected when MCR7 is set to 1.

8.3.1.1 Trigger Levels

The TL16C752CI-Q1 UART provides independent selectable and programmable trigger levels for both receiver and transmitter DMA and interrupt generation. After reset, both transmitter and receiver FIFOs are disabled and so, in effect, the trigger level is the default value of one byte. The selectable trigger levels are available through the FCR. The programmable trigger levels are available through the TLR.

Feature Description (continued)

8.3.1.2 Hardware Flow Control

Hardware flow control is composed of auto- $\overline{\text{CTS}}$ and auto- $\overline{\text{RTS}}$. Auto- $\overline{\text{CTS}}$ and auto- $\overline{\text{RTS}}$ can be enabled or disabled independently by programming EFR[7:6].

With auto- $\overline{\text{CTS}}$, $\overline{\text{CTS}}$ must be active before the UART can transmit data. Auto- $\overline{\text{RTS}}$ only activates the $\overline{\text{RTS}}$ output when there is enough room in the FIFO to receive data and deactivates the $\overline{\text{RTS}}$ output when the RX FIFO is sufficiently full. The HALT and RESTORE trigger levels in the TCR determine the levels at which $\overline{\text{RTS}}$ is activated or deactivated. If both auto- $\overline{\text{CTS}}$ and auto- $\overline{\text{RTS}}$ are enabled, when $\overline{\text{RTS}}$ is connected to $\overline{\text{CTS}}$, data transmission does not occur unless the receiver FIFO has empty space. Thus, overrun errors are eliminated during hardware flow control. If not enabled, overrun errors occur if the transmit data rate exceeds the receive FIFO servicing latency.

8.3.1.3 Auto- $\overline{\text{RTS}}$

Auto- $\overline{\text{RTS}}$ data flow control originates in the receiver block (see Figure 14). Figure 16 shows $\overline{\text{RTS}}$ functional timing. The receiver FIFO trigger levels used in Auto- $\overline{\text{RTS}}$ are stored in the TCR. $\overline{\text{RTS}}$ is active if the RX FIFO level is below the HALT trigger level in TCR[3:0]. When the receiver FIFO HALT trigger level is reached, $\overline{\text{RTS}}$ is deasserted. The sending device (for example, another UART) may send an additional byte after the trigger level is reached (assuming the sending UART has another byte to send) because it may not recognize the deassertion of $\overline{\text{RTS}}$ until it has begun sending the additional byte. $\overline{\text{RTS}}$ is automatically reasserted once the receiver FIFO reaches the RESUME trigger level programmed via TCR[7:4]. This reassertion allows the sending device to resume transmission.

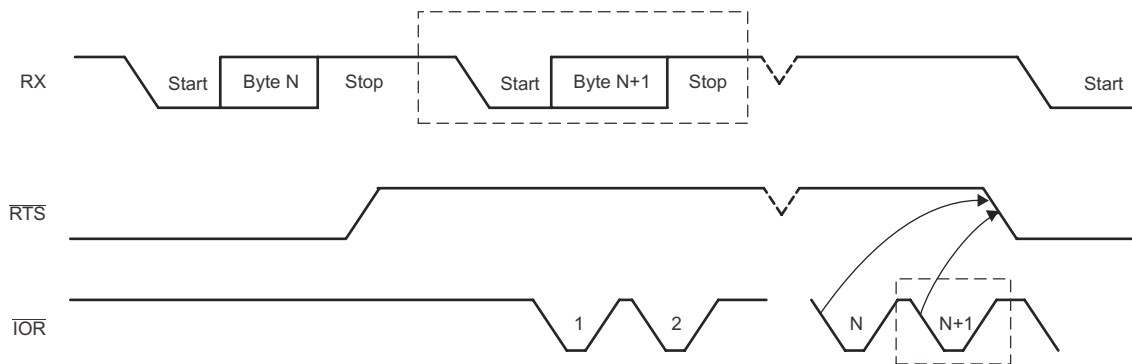

- A. N = receiver FIFO trigger level B.
- B. The two blocks in dashed lines cover the case where an additional byte is sent as described in Auto- $\overline{\text{RTS}}$.

Figure 16. $\overline{\text{RTS}}$ Functional Timing

8.3.1.4 Auto- $\overline{\text{CTS}}$

The transmitter circuitry checks $\overline{\text{CTS}}$ before sending the next data byte. When $\overline{\text{CTS}}$ is active, the transmitter sends the next byte. To stop the transmitter from sending the following byte, $\overline{\text{CTS}}$ must be deasserted before the middle of the last stop bit that is currently being sent. The auto- $\overline{\text{CTS}}$ function reduces host interrupts to the host system. When flow control is enabled, the $\overline{\text{CTS}}$ state changes and need not trigger host interrupts because the device automatically controls its own transmitter. Without auto- $\overline{\text{CTS}}$, the transmitter sends any data present in the transmit FIFO and a receiver overrun error can result. Figure 17 shows $\overline{\text{CTS}}$ functional timing, and Figure 18 shows an example of autoflow control.

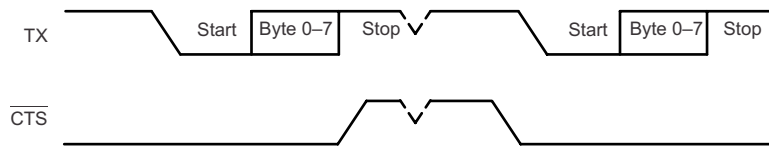
Feature Description (continued)

- When $\overline{\text{CTS}}$ is low, the transmitter keeps sending serial data out.
- When $\overline{\text{CTS}}$ goes high before the middle of the last stop bit of the current byte, the transmitter finishes sending the current byte, but it does not send the next byte.
- When $\overline{\text{CTS}}$ goes from high to low, the transmitter begins sending data again.

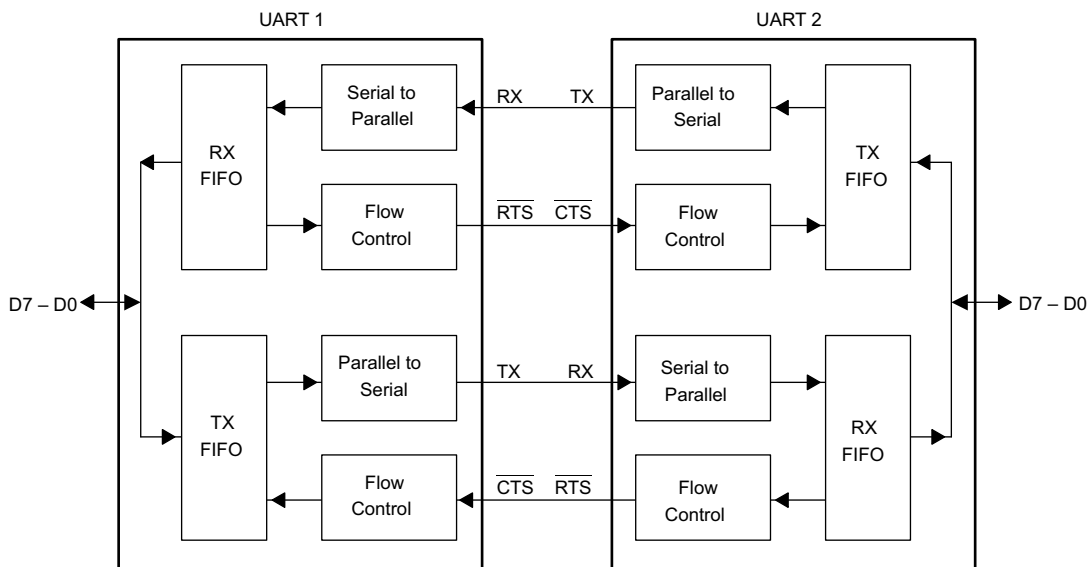
Figure 17. $\overline{\text{CTS}}$ Functional Timing

Figure 18. Autoflow Control (Auto-RTS and Auto-CTS) Example
8.3.1.5 Software Flow Control

Software flow control is enabled through the enhanced feature register and the modem control register. Different combinations of software flow control can be enabled by setting different combinations of EFR[3-0]. [Table 1](#) shows software flow control options.

Two other enhanced features relate to software flow control:

- **Xon Any Function [MCR(5)]**: Operation resumes after receiving any character after recognizing the Xoff character.
- **Special Character [EFR(5)]**: Incoming data is compared to Xoff2. Detection of the special character sets the Xoff interrupt [IIR(4)] but does not halt transmission. The Xoff interrupt is cleared by a read of the IIR. The special character is transferred to the RX FIFO.

NOTE

It is possible for an Xon1 character to be recognized as an Xon Any character, which could cause an Xon2 character to be written to the RX FIFO.

Table 1. Software Flow Control Options EFR[3:0]

BIT 3	BIT 2	BIT 1	BIT 0	TX, RX SOFTWARE FLOW CONTROLS
0	0	X	X	No transmit flow control
1	0	X	X	Transmit Xon1, Xoff1
0	1	X	X	Transmit Xon2, Xoff2
1	1	X	X	Transmit Xon1, Xon2: Xoff1, Xoff2
X	X	0	0	No receive flow control
X	X	1	0	Receiver compares Xon1, Xoff1 X X 0 1
X	X	0	1	Receiver compares Xon2, Xoff2
1	0	1	1	Transmit Xon1, Xoff1 Receiver compares Xon1 or Xon2, Xoff1 or Xoff2
0	1	1	1	Transmit Xon2, Xoff2 Receiver compares Xon1 or Xon2, Xoff1 or Xoff2
1	1	1	1	Transmit Xon1, Xon2: Xoff1, Xoff2 Receiver compares Xon1 and Xon2: Xoff1 and Xoff2
0	0	1	1	No transmit flow control Receiver compares Xon1 and Xon2: Xoff1 and Xoff2

When software flow control operation is enabled, the TL16C752CI-Q1 device compares incoming data with Xoff1 and Xoff2 programmed characters (in certain cases Xoff1 and Xoff2 must be received sequentially). ⁽¹⁾ When an Xoff character is received, transmission is halted after completing transmission of the current character. Xoff character detection also sets IIR[4] and causes INT to go high (if enabled via IER[5]).

To resume transmission an Xon1 and Xon2 character must be received (in certain cases Xon1 and Xon2 must be received sequentially). When the correct Xon characters are received IIR[4] is cleared and the Xoff interrupt disappears.

NOTE

If a parity, framing, or break error occurs while receiving a software flow control character, this character is treated as normal data and is written to the RCV FIFO.

Xoff1 and Xoff2 characters are transmitted when the RX FIFO has passed the programmed trigger level TCR[3:0].

Xon1 and Xon2 characters are transmitted when the RX FIFO reaches the trigger level programmed via TCR[7:4].

NOTE

If, after an Xoff character has been sent, software flow control is disabled, the UART transmits Xon characters automatically to enable normal transmission to proceed. A feature of the TL16C752CI-Q1 UART design is that if the software flow combination (EFR[3:0]) changes after an Xoff has been sent, the originally programmed Xon is automatically sent. If the RX FIFO is still above the trigger level, the newly programmed Xoff1 or Xoff2 is transmitted.

The transmission of Xoff and Xon follows the exact same protocol as transmission of an ordinary byte from the FIFO. This means that even if the word length is set to be 5, 6, or 7 characters, then the 5, 6, or 7 least significant bits of Xoff1, Xoff2 and Xon1, Xon2 are transmitted. The transmission of 5, 6, or 7 bits of a character is seldom done, but this functionality is included to maintain compatibility with earlier designs.

It is assumed that software flow control and hardware flow control are never enabled simultaneously. [Figure 19](#) shows a software flow control example.

(1) When pairs of Xon and Xoff characters are programmed to occur sequentially, received Xon1 and Xoff1 characters will be written to the RX FIFO if the subsequent character is not Xon2 and Xoff2.

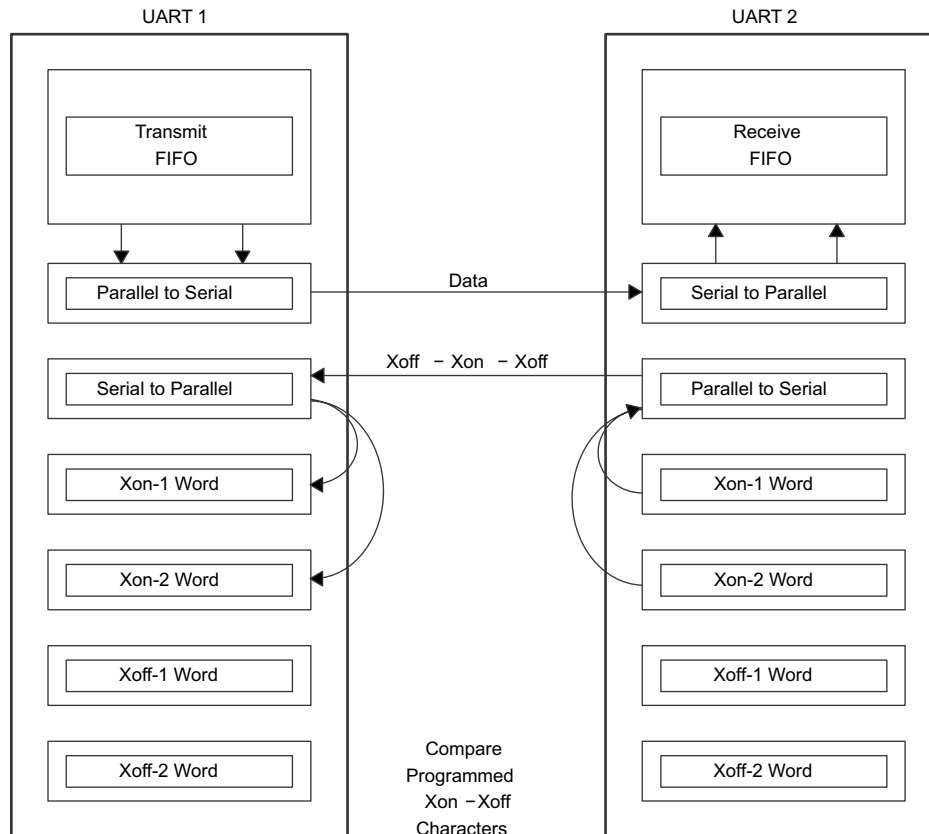

Figure 19. Software Flow Control Example

8.3.1.6 Software Flow Control Example

Assumptions: UART1 is transmitting a large text file to UART2. Both UARTs are using software flow control with single character Xoff (0F) and Xon (0D) tokens. Both have Xoff threshold (TCR [3:0] = F) set to 60 and Xon threshold (TCR[7:4] = 8) set to 32. Both have the interrupt receive threshold (TLR[7:4] = D) set to 52.

UART1 begins transmission and sends 52 characters, at which point UART2 generates an interrupt to its processor to service the RCV FIFO, but assumes the interrupt latency is fairly long. UART1 continues sending characters until a total of 60 characters have been sent. At this time UART2 transmits a 0F to UART1, informing UART1 to halt transmission. UART1 likely sends the 61st character while UART2 is sending the Xoff character. Now, UART2 is serviced and the processor reads enough data out of the RCV FIFO that the level drops to 32. UART2 now sends a 0D to UART1, informing UART1 to resume transmission.

8.3.1.7 Reset

Table 2 summarizes the state of outputs after reset.

Table 2. Register Reset Functions⁽¹⁾

REGISTER	RESET CONTROL	RESET STATE
Interrupt enable register	RESET	All bits cleared
Interrupt identification register	RESET	Bit 0 is set. All other bits cleared.
FIFO control register	RESET	All bits cleared
Line control register	RESET	Reset to 00011101 (1D hex)
Modem control register	RESET	All bits cleared
Line status register	RESET	Bits 5 and 6 set. All other bits cleared.
Modem status register	RESET	Bits 0 to 3 cleared. Bits 4 to 7 input signals.
Enhanced feature register	RESET	All bits cleared
Receiver holding register	RESET	Pointer logic cleared
Transmitter holding register	RESET	Pointer logic cleared
Transmission control register	RESET	All bits cleared
Trigger level register	RESET	All bits cleared
Alternate function register	RESET	All bits (except AFR4) cleared; AFR4 set

(1) Registers DLL, DLH, SPR, Xon1, Xon2, Xoff1, and Xoff2 are not reset by the top-level reset signal RESET, that is, they hold their initialization values during reset.

Table 3 summarizes the state of outputs after reset.

Table 3. Signal Reset Functions

SIGNAL	RESET CONTROL	RESET STATE
TX	RESET	High
$\overline{\text{RTS}}$	RESET	High
$\overline{\text{DTR}}$	RESET	High
$\overline{\text{RXRDYA-B}}$	RESET	High
$\overline{\text{TXRDYA-B}}$	RESET	Low

8.3.1.8 Interrupts

The TL16C752CI-Q1 UART has interrupt generation and prioritization (six prioritized levels of interrupts) capability. The interrupt enable register (IER) enables each of the six types of interrupts and the INT signal in response to an interrupt generation. The IER also can disable the interrupt system by clearing bits 0 to 3, 5 to 7. When an interrupt is generated, the interrupt identification register (IIR) indicates that an interrupt is pending and provides the type of interrupt through IIR[5–0]. [Table 4](#) summarizes the interrupt control functions.

Table 4. Interrupt Control Functions

IIR[5–0]	PRIORITY LEVEL	INTERRUPT TYPE	INTERRUPT SOURCE	INTERRUPT RESET METHOD
000001	None	None	None	None
000110	1	Receiver line status	OE, FE, PE, or BI errors occur in characters in the RX FIFO	FE < PE < BI: All erroneous characters are read from the RX FIFO. OE: Read LSR
001100	2	RX timeout	Stale data in RX FIFO	Read RHR
000100	2	RHR interrupt	DRDY (data ready) (FIFO disable) RX FIFO above trigger level (FIFO enable)	Read RHR
000010	3	THR interrupt	TFE (THR empty) (FIFO disable) TX FIFO passes above trigger level (FIFO enable)	Read IIR or a write to the THR
000000	4	Modem status	MSR[3:0] = 0	Read MSR
010000	5	Xoff interrupt	Receive Xoff character or characters/special character	Receive Xon character or characters/Read of IIR
100000	6	$\overline{\text{CTS}}$, $\overline{\text{RTS}}$	$\overline{\text{RTS}}$ pin or $\overline{\text{CTS}}$ pin change state from active (low) to inactive (high)	Read IIR

It is important to note that for the framing error, parity error, and break conditions, LSR[7] generates the interrupt. LSR[7] is set when there is an error anywhere in the RX FIFO and is cleared only when there are no more errors remaining in the FIFO. LSR[4–2] always represent the error status for the received character at the top of the RX FIFO. Reading the RX FIFO updates LSR[4–2] to the appropriate status for the new character at the top of the FIFO. If the RX FIFO is empty, then LSR[4–2] is all 0.

For the Xoff interrupt, if an Xoff flow character detection caused the interrupt, the interrupt is cleared by an Xon flow character detection. If a special character detection caused the interrupt, the interrupt is cleared by a read of the ISR.

8.3.1.9 Interrupt Mode Operation

In interrupt mode (if any bit of IER[3:0] is 1), the processor is informed of the status of the receiver and transmitter by an interrupt signal, INT. Therefore, it is not necessary to continuously poll the line status register (LSR) to see if any interrupt needs to be serviced. [Figure 20](#) shows interrupt mode operation.

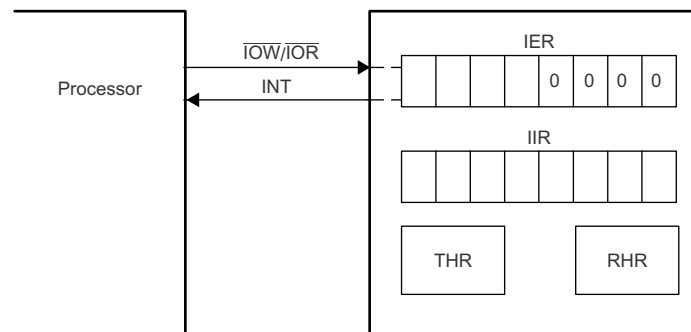

Figure 20. Interrupt Mode Operation

8.3.1.10 Polled Mode Operation

In polled mode (IER[3:0] = 0000), the status of the receiver and transmitter can then be checked by polling the line status register (LSR). This mode is an alternative to the interrupt mode of operation where the status of the receiver and transmitter is automatically known by means of interrupts sent to the CPU. Figure 21 shows polled mode operation.

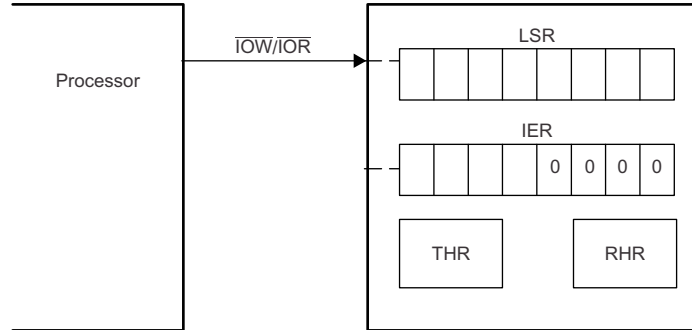

Figure 21. FIFO Polled Mode Operation

8.3.1.11 Break and Timeout Conditions

An RX timeout condition is detected when the receiver line, RX, has been high for a time equivalent to (4 x programmed word length) + 12 bits and there is at least one byte stored in the RX FIFO.

When a break condition occurs, the TX line is pulled low. A break condition is activated by setting LCR[6].

8.3.1.12 Programmable Baud Rate Generator

The TL16C752CI-Q1 UART contains a programmable baud generator that divides reference clock by a divisor in the range between 1 and $(2^{16} - 1)$. The output frequency of the baud rate generator is 16x the baud rate. An additional divide-by-4 prescaler is also available and can be selected by MCR[7], as shown in the following. The formula for the divisor is:

$$\text{Divisor} = (\text{XTAL crystal input frequency} / \text{prescaler}) / (\text{desired baud rate} \times 16)$$

Where

$$\text{prescaler} = \begin{cases} 1 & \text{when CLKSEL = high during reset, or MCR[7] is set to 0 after reset} \\ 4 & \text{when CLKSEL = high during reset, or MCR[7] is set to 1 after reset} \end{cases}$$

Figure 22 shows the internal prescaler and baud rate generator circuitry.

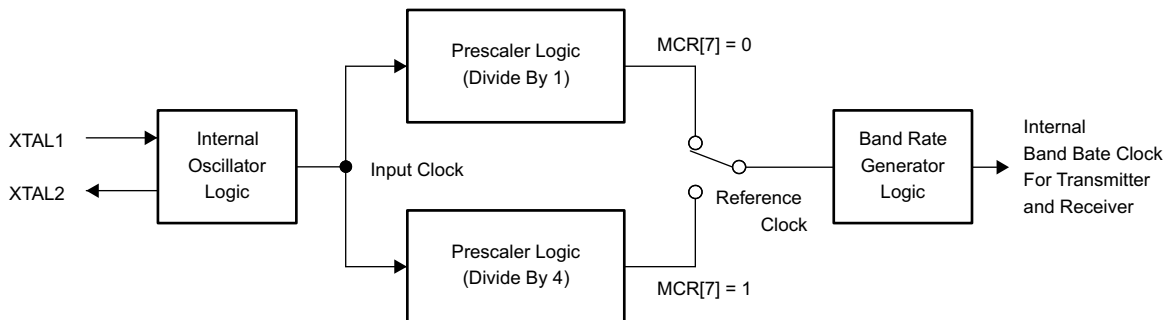

Figure 22. Prescaler and Baud Rate Generator Block Diagram

DLL and DLH must be written to to program the baud rate. DLL and DLH are the least significant and most significant byte of the baud rate divisor. If DLL and DLH are both 0, the UART is effectively disabled, because no baud clock is generated. The programmable baud rate generator is provided to select both the transmit and receive clock rates. Table 5 and Table 6 show the baud rate and divisor correlation for the crystal with frequency 1.8432 and 3.072 MHz, respectively.

Table 5. Baud Rates Using a 1.8432-MHz Crystal

DESIRED BAUD RATE	DIVISOR USED TO GENERATE 16x CLOCK	PERCENT ERROR DIFFERENCE BETWEEN DESIRED AND ACTUAL
50	2304	
75	1536	
110	1047	0.026
134.5	857	0.058
150	768	
300	384	
600	192	
1200	96	
1800	64	
2000	58	0.69
2400	48	
3600	32	
4800	24	
7200	16	
9600	12	
19200	6	
38400	3	
56000	2	2.86

Table 6. Baud Rates Using a 3.072-MHz Crystal

DESIRED BAUD RATE	DIVISOR USED TO GENERATE 16x CLOCK	PERCENT ERROR DIFFERENCE BETWEEN DESIRED AND ACTUAL
50	3840	
75	2560	
110	1745	0.026
134.5	1428	0.034
150	1280	
300	640	
600	320	
1200	160	
1800	107	0.312
2000	96	
2400	80	
3600	53	0.628
4800	40	
7200	27	1.23
9600	20	
19200	10	
38400	5	

Figure 23 shows the crystal clock circuit reference.

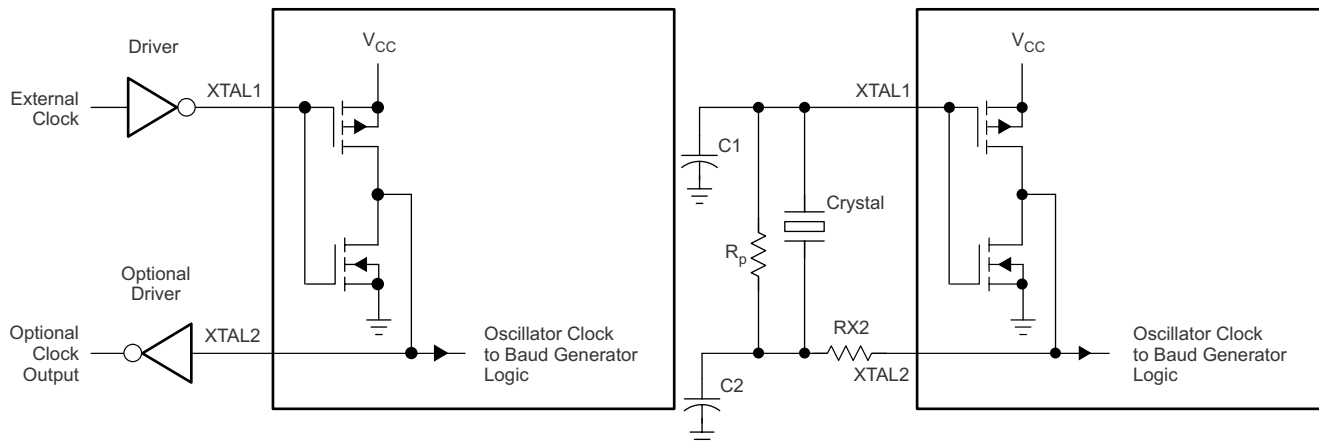

- A. For crystal with fundamental frequency from 1 to 24 MHz
- B. For input clock frequency higher than 24 MHz, the crystal is not allowed and the oscillator must be used, because the TL16C752CI-Q1 internal oscillator cell can only support the crystal frequency up to 24 MHz.

Figure 23. Typical Crystal Clock Circuits

8.4 Device Functional Modes

8.4.1 DMA Signaling

There are two modes of DMA operation, DMA mode 0 or 1, selected by FCR[3].

In DMA mode 0 or FIFO disable (FCR[0] = 0), DMA occurs in single character transfers. In DMA mode 1, multicharacter (or block) DMA transfers are managed to relieve the processor for longer periods of time.

8.4.1.1 Single DMA Transfers (DMA Mode0 or FIFO Disable)

Transmitter: When empty, the $\overline{\text{TXRDY}}$ signal becomes active. $\overline{\text{TXRDY}}$ goes inactive after one character has been loaded into it.

Receiver: $\overline{\text{RXRDY}}$ is active when there is at least one character in the FIFO. It becomes inactive when the receiver is empty.

Figure 24 shows $\overline{\text{TXRDY}}$ and $\overline{\text{RXRDY}}$ in DMA mode 0 or FIFO disable.

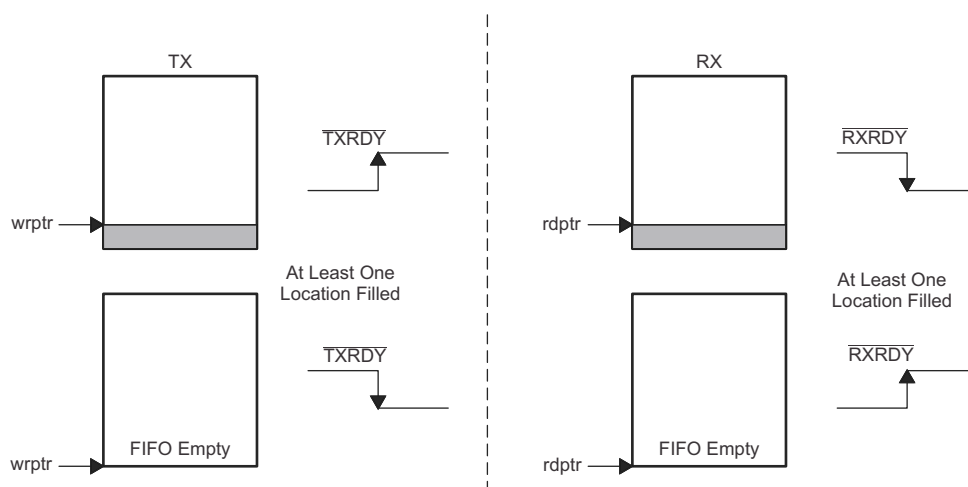

Figure 24. $\overline{\text{TXRDY}}$ and $\overline{\text{RXRDY}}$ in DMA Mode 0 or FIFO Disable

Device Functional Modes (continued)

8.4.1.2 Block DMA Transfers (DMA Mode 1)

Transmitter: $\overline{\text{TXRDY}}$ is active when a trigger level number of spaces are available. It becomes inactive when the FIFO is full.

Receiver: $\overline{\text{RXRDY}}$ becomes active when the trigger level has been reached or when a timeout interrupt occurs. It goes inactive when the FIFO is empty or an error in the RX FIFO is flagged by LSR(7).

Figure 25 shows $\overline{\text{TXRDY}}$ and $\overline{\text{RXRDY}}$ in DMA mode 1.

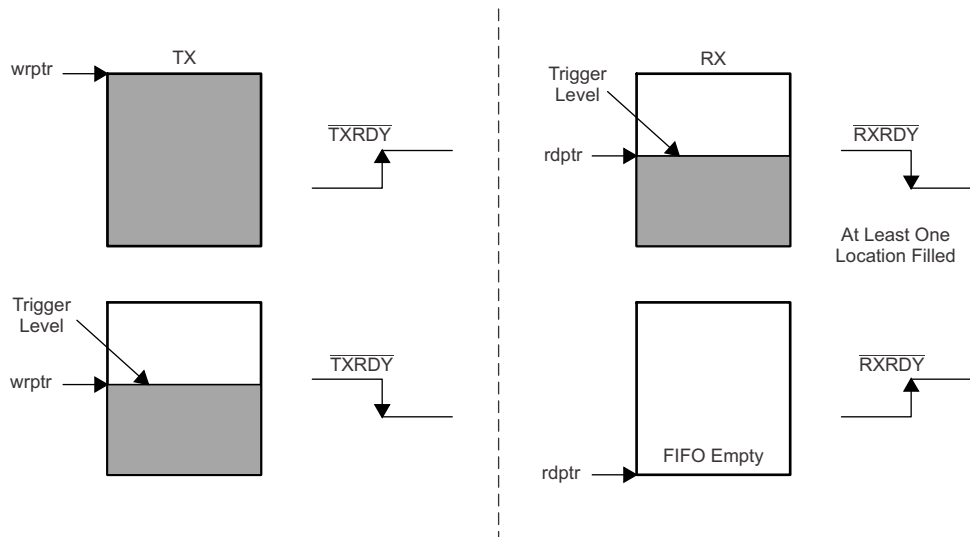

Figure 25. $\overline{\text{TXRDY}}$ and $\overline{\text{RXRDY}}$ in DMA Mode 1

8.4.2 Sleep Mode

Sleep mode is an enhanced feature of the TL16C752CI-Q1 UART. It is enabled when EFR[4], the enhanced functions bit, is set and when IER[4] is set. Sleep mode is entered when:

- The serial data input line, RX, is idle (see [Break and Timeout Conditions](#)).
- The TX FIFO and TX shift register are empty.
- There are no interrupts pending except THR and timeout interrupts.

Sleep mode is not entered if there is data in the RX FIFO.

In sleep mode, the UART clock and baud rate clock are stopped. Because most registers are clocked using these clocks, the power consumption is greatly reduced. The UART wakes up when any change is detected on the RX line, when there is any change in the state of the modem input pins, or if data is written to the TX FIFO.

NOTE

Writing to the divisor latches, DLL and DLH, to set the baud clock, must not be done during sleep mode. Therefore, TI recommends to disable sleep mode using IER[4] before writing to DLL or DLH.

8.5 Register Maps

8.5.1 Principals of Operation

Each register is selected using address lines A[0], A[1], A[2], and in some cases, bits from other registers. The programming combinations for register selection are shown in [Figure 26](#).

ADDRESS [A2:A0]	READ MODE			WRITE MODE		
000	RHR Receive Holding	DLL Divisor Latch LSB		THR Transmit Holding	DLL Divisor Latch LSB	
001	IER Interrupt Enable	DLH Divisor Latch MSB		IER Interrupt Enable	DLH Divisor Latch MSB	
010	IIR Interrupt Identification	AFR Alternate Function	EFR Enhanced feature	FCR FIFO Control	AFR Alternate Function	EFR Enhanced feature
011	LCR Line Control			LCR Line Control		
100	MCR Modem Control	Xon1 Xon 1 word		MCR Modem Control	Xon1 Xon 1 word	
101	LSR Line Status	Xon2 Xon 2 word			Xon2 Xon 2 word	
110	MSR Modem Status	Xoff1 Xoff 1 word	TCR Transmission Control		Xoff1 Xoff 1 word	TCR Transmission Control
111	SPR Scratch Register	Xoff2 Xoff 2 word	TLR Trigger Level	FIFO RDY FIFO Ready Register	SPR Scratch Register	Xoff2 Xoff 2 word
						TLR Trigger Level

- Accessible only when LCR[7] = 1
- Accessible only when LCR[7:5] = 100
- Accessible only when LCR = 1011 1111 (0xBF)
- Accessible only when EFR[4] = 1 and MCR[6] = 1
- Accessible when any CS A-B = 0, MCR[2] = 1 and loopback MCR[4] = 0 is disabled

NOTE: MCR[7:5], FCR[5:4], and IER[7:4] can only be modified when EFR[4] is set.

Figure 26. Register Map – Read and Write Properties

[Table 7](#) lists and describes the TL16C752CI-Q1 internal registers.

Table 7. TL16C752CI-Q1 Internal Registers⁽¹⁾ (2)

ADDRESS	REGISTER	R/W ⁽³⁾	ACCESS CONSIDERATION	BIT 7	BIT 6	BIT 5	BIT 4	BIT 3	BIT 2	BIT 1	BIT 0
0 0 0	RHR	R	LCR[7] = 0	bit 7 0	bit 6 0	bit 5 0	bit 4 0	bit 3 0	bit 2 0	bit 1 0	bit 0 0
	THR	W		bit 7 0	bit 6 0	bit 5 0	bit 4 0	bit 3 0	bit 2 0	bit 1 0	bit 0 0
	DLL ⁽⁴⁾	RW	LCR[7] = 1	bit 7	bit 6	bit 5	bit 4	bit 3	bit 2	bit 1	bit 0
0 0 1	IER	RW	LCR[7] = 0	CTS# Interrupt enable ⁽¹⁾ 0	RTS# Interrupt enable ⁽¹⁾ 0	Xoff Interrupt enable ⁽¹⁾ 0	Sleep mode ⁽¹⁾ 0	Modem status interrupt 0	RX line status interrupt 0	THR empty interrupt 0	RX data available interrupt 0
	DLH ⁽⁴⁾	RW	LCR[7] = 1	bit 7	bit 6	bit 5	bit 4	bit 3	bit 2	bit 1	bit 0
0 1 0	IIR	R	LCR[7] = 0	FCR(0) 0	FCR(0) 0	CTS# / RTS# 0	Xoff 0	Interrupt priority bit 2 0	Interrupt priority bit 1 0	Interrupt priority bit 0 0	Interrupt status 1
	FCR	W		RX trigger level 0	RX trigger level 0	TX trigger level ⁽¹⁾ 0	TX trigger level ⁽¹⁾ 0	DMA mode select 0	Resets TX FIFO 0	Resets RX FIFO 0	Enable FIFOs 0
	AFR ⁽⁵⁾	RW	LCR[7:5] = 100	DLY2 0	DLY1 0	DLY0 0	RCVEN 1	485LG 0	485RN 0	IREN 0	CONC 0
	EFR ⁽⁶⁾	RW	LCR[7:0] = 10111111	Auto CTS# 0	Auto RTS# 0	Special character detect 0	Enable enhanced functions 0	S/W flow control bit 3 0	S/W flow control bit 2 0	S/W flow control bit 1 0	S/W flow control bit 0 0
0 1 1	LCR	RW	None	DLAB & EFR enable 0	Break control bit 0	Sets parity 0	Parity type select 1	Parity enable 1	No. of stop bits 1	Word length 0	Word length 1
1 0 0	MCR	RW	LCR[7:0] ≠ 10111111	1x / 4x clock ⁽¹⁾ 0	TCR & TLR enable ⁽¹⁾ 0	Xon any ⁽¹⁾ 0	Enable loopback 0	IRQ enable 0	FIFORdy enable 0	RTS# 0	DTR# 0
	Xon1 ⁽⁶⁾	RW	LCR[7:0] = 10111111	bit 7 1	bit 6 1	bit 5 1	bit 4 1	bit 3 1	bit 2 1	bit 1 1	bit 0 1
1 0 1	LSR	R	LCR[7:0] ≠ 10111111	Error in RX FIFO 0	THR & TSR empty 1	THR empty 1	Break interrupt 0	Framing error 0	Parity error 0	Overrun error 0	Data in receiver 0
	Xon2 ⁽⁶⁾	RW	LCR[7:0] = 10111111	bit 7 1	bit 6 1	bit 5 1	bit 4 0	bit 3 1	bit 2 1	bit 1 1	bit 0 1

(1) Bits represented by the blue shaded cells can only be modified if EFR[4] is enabled, that is, if enhanced functions are enabled.

(2) For more register access information, see [Figure 26](#).

(3) Read = R; Write = W

(4) This register is only accessible when LCR[7] = 1

(5) This register is only accessible LCR[7:5] = 100

(6) This register is only accessible when LCR = 1011 1111 (0xBF)

Table 7. TL16C752CI-Q1 Internal Registers^{0 0} (continued)

ADDRESS	REGISTER	R/W ⁽³⁾	ACCESS CONSIDERATION	BIT 7	BIT 6	BIT 5	BIT 4	BIT 3	BIT 2	BIT 1	BIT 0
1 1 0	MSR	R	LCR[7:0] ≠ 10111111	CD# 1	RI# 1	DSR# 1	CTS# 0	ΔCD# 0	ΔRI# 0	ΔDSR# 0	ΔCTS# 0
	Xoff1 ⁽⁶⁾	RW	LCR[7:0] = 10111111	bit 7 1	bit 6 1	bit 5 1	bit 4 1	bit 3 1	bit 2 1	bit 1 1	bit 0 1
	TCR ⁽⁷⁾	RW	EFR[4] = 1 & MCR[6] = 1	bit 7 0	bit 6 0	bit 5 0	bit 4 0	bit 3 0	bit 2 0	bit 1 0	bit 0 0
1 1 1	SPR	RW	LCR[7:0] ≠ 10111111	bit 7 1	bit 6 1	bit 5 1	bit 4 1	bit 3 1	bit 2 1	bit 1 1	bit 0 1
	Xoff2 ⁽⁶⁾	RW	LCR[7:0] = 10111111	bit 7 1	bit 6 1	bit 5 1	bit 4 1	bit 3 1	bit 2 1	bit 1 1	bit 0 1
	TLR ⁽⁷⁾	RW	EFR[4] = 1 & MCR[6] = 1	bit 7 0	bit 6 0	bit 5 0	bit 4 0	bit 3 0	bit 2 0	bit 1 0	bit 0 0
	FIFORdy ⁽⁸⁾	R	MCR[4] = 0 & MCR[2] = 1	RX FIFO D status 0	RX FIFO C status 0	RX FIFO B status 0	RX FIFO A status 0	TX FIFO D status 0	TX FIFO C status 0	TX FIFO B status 0	TX FIFO A status 0

(7) This register is only accessible when EFR[4] = 1 and MCR[6] = 1

(8) This register is accessible when any CS A-B = 0, MCR[2] = 1, and loopback MCR[4] = 0 is disabled

8.5.2 Receiver Holding Register (RHR)

The receiver section consists of the RHR and the receiver shift register (RSR). The RHR is actually a 64-byte FIFO. The RSR receives serial data from RX terminal. The data is converted to parallel data and moved to the RHR. The receiver section is controlled by the line control register. If the FIFO is disabled, location 0 of the FIFO is used to store the characters. If overflow occurs, characters are lost. The RHR also stores the error status bits associated with each character.

8.5.3 Transmit Holding Register (THR)

The transmitter section consists of the THR and the transmitter shift register (TSR). The transmit holding register is actually a 64-byte FIFO. The THR receives data and shifts it into the TSR where it is converted to serial data and moved out on the TX terminal. If the FIFO is disabled, location 0 of the FIFO is used to store the byte. Characters are lost if overflow occurs.

8.5.4 FIFO Control Register (FCR)

This is a write-only register which is used for enabling the FIFOs, clearing the FIFOs, setting transmitter and receiver trigger levels, and selecting the type of DMA signaling. [Table 8](#) shows FIFO control register bit settings.

Table 8. FCR Bit Settings

BIT	BIT SETTINGS
0	0 = Disable the transmit and receive FIFOs 1 = Enable the transmit and receive FIFOs
1	0 = No change 1 = Clears the receive FIFO and resets its counter logic to 0. Returns to 0 after clearing FIFO.
2	0 = No change 1 = Clears the transmit FIFO and resets its counter logic to 0. Returns to 0 after clearing FIFO.
3	0 = DMA mode 0 1 = DMA mode 1
5:4 ⁽¹⁾	Sets the trigger level for the TX FIFO: 00 – 8 spaces 01 – 16 spaces 10 – 32 spaces 11 – 56 spaces
7:6	Sets the trigger level for the RX FIFO: 00 – 1 characters 01 – 4 characters 10 – 56 characters 11 – 60 characters

(1) FCR[5–4] can be modified and enabled only when EFR[4] is set. This is because the transmit trigger level is regarded as an enhanced function.

8.5.5 Line Control Register (LCR)

This register controls the data communication format. The word length, number of stop bits, and parity type are selected by writing the appropriate bits to the LCR. [Table 9](#) shows line control register bit settings.

Table 9. LCR Bit Settings

BIT	BIT SETTINGS
1:0	Specifies the word length to be transmitted or received 00 – 5 bits 01 – 6 bits 10 – 7 bits 11 – 8 bits
2	Specifies the number of stop bits: 0 – 1 stop bits (Word length = 5, 6, 7, 8) 1 – 1.5 stop bits (Word length = 5) 1 – 2 stop bits (Word length = 6, 7, 8) 3
3	0 = No parity 1 = A parity bit is generated during transmission and the receiver checks for received parity.
4	0 = Odd parity is generated (if LCR[3] = 1) 1 = Even parity is generated (if LCR[3] = 1)
5	Selects the forced parity format (if LCR(3) = 1) If LCR[5] = 1 and LCR[4] = 0 the parity bit is forced to 1 in the transmitted and received data. If LCR[5] = 1 and LCR[4] = 1 the parity bit is forced to 0 in the transmitted and received data.
6	Break control bit 0 = Normal operating condition 1 = Forces the transmitter output to go low to alert the communication terminal.
7	0 = Normal operating condition 1 = Divisor latch enable

8.5.6 Line Status Register (LSR)

Table 10 shows line status register bit settings.

Table 10. LSR Bit Settings

BIT	BIT SETTINGS
0	0 = No data in the receive FIFO 1 = At least one character in the RX FIFO
1	0 = No overrun error 1 = Overrun error has occurred.
2	0 = No parity error in data being read from RX FIFO 1 = Parity error in data being read from RX FIFO
3	0 = No framing error in data being read from RX FIFO 1 = Framing error occurred in data being read from RX FIFO (that is, received data did not have a valid stop bit)
4	0 = No break condition 1 = A break condition occurred and associated byte is 00 (that is, RX was low for at least one character time frame)
5	0 = Transmit hold register is not empty 1 = Transmit hold register is empty. The processor can now load up to 64 bytes of data into the THR if the TX FIFO is enabled.
6	0 = Transmitter hold and shift registers are not empty. 1 = Transmitter hold and shift registers are empty.
7	0 = Normal operation 1 = At least one parity error, framing error or break indication are stored in the receiver FIFO. Bit 7 is cleared when no errors are present in the FIFO.

When the LSR is read, LSR[4:2] reflects the error bits [BI, FE, PE] of the character at the top of the RX FIFO (next character to be read). The LSR[4:2] registers do not physically exist, as the data read from the RX FIFO is output directly onto the output data-bus, DI[4:2], when the LSR is read. Therefore, errors in a character are identified by reading the LSR and then reading the RHR.

LSR[7] is set when there is an error anywhere in the RX FIFO and is cleared only when there are no more errors remaining in the FIFO.

NOTE

Reading the LSR does not cause an increment of the RX FIFO read pointer. The RX FIFO read pointer is incremented by reading the RHR.

8.5.7 Modem Control Register (MCR)

The MCR controls the interface with the modem, data set, or peripheral device that is emulating the modem. [Table 11](#) shows modem control register bit settings.

Table 11. MCR Bit Settings⁽¹⁾

BIT	BIT SETTINGS
0	0 = Force $\overline{\text{DTR}}$ output to inactive (high) 1 = Force $\overline{\text{DTR}}$ output to active (low). In loopback controls MSR[5]
1	0 = Force $\overline{\text{RTS}}$ output to inactive (high) 1 = Force $\overline{\text{RTS}}$ output to active (low) In loopback controls MSR[4] If Auto-RTS is enabled the $\overline{\text{RTS}}$ output is controlled by hardware flow control
2	0 Disables the FIFORdy register 1 Enable the FIFORdy register In loopback controls MSR[6]
3	0 = Forces the IRQ(A-B) outputs to high-impedance state 1 = Forces the IRQ(A-B) outputs to the active state In loopback controls MSR[7]
4	0 = Normal operating mode 1 = Enable local loopback mode (internal) In this mode, the MCR[3:0] signals are looped back into MSR[3:0] and the TX output is looped back to the RX input internally
5	0 = Disable Xon Any function 1 = Enable Xon Any function
6	0 = No action 1 = Enable access to the TCR and TLR registers
7	0 = Divide by one clock input 1 = Divide by four clock input This bit reflects the inverse of the CLKSEL pin value at the trailing edge of the RESET pulse

(1) MCR[7:5] can be modified only when EFR[4] is set, that is, EFR[4] is a write enable.

8.5.8 Modem Status Register (MSR)

This 8-bit register provides information about the current state of the control lines from the modem, data set, or peripheral device to the processor. It also indicates when a control input from the modem changes state. [Table 12](#) shows modem status register bit settings.

Table 12. MSR Bit Settings⁽¹⁾

BIT	BIT SETTINGS
0	Indicates that $\overline{\text{CTS}}$ input (or MCR[1] in loopback) has changed state. Cleared on a read.
1	Indicates that $\overline{\text{DSR}}$ input (or MCR[0] in loopback) has changed state. Cleared on a read.
2	Indicates that $\overline{\text{RI}}$ input (or MCR[2] in loopback) has changed state from low to high. Cleared on a read.
3	Indicates that $\overline{\text{CD}}$ input (or MCR[3] in loopback) has changed state. Cleared on a read.
4	This bit is equivalent to MCR[1] during local loop-back mode. It is the complement to the $\overline{\text{CTS}}$ input.
5	This bit is equivalent to MCR[0] during local loop-back mode. It is the complement to the $\overline{\text{DSR}}$ input.
6	This bit is equivalent to MCR[2] during local loop-back mode. It is the complement to the $\overline{\text{RI}}$ input.
7	This bit is equivalent to MCR[3] during local loop-back mode. It is the complement to the $\overline{\text{CD}}$ input.

(1) The primary inputs $\overline{\text{RI}}$, $\overline{\text{CD}}$, $\overline{\text{CTS}}$, and $\overline{\text{DSR}}$ are all active low, but their registered equivalents in the MSR and MCR (in loopback) registers are active high.

8.5.9 Interrupt Enable Register (IER)

The interrupt enable register (IER) enables each of the six types of interrupt, receiver error, RHR interrupt, THR interrupt, Xoff received, or CTS/RTS change of state from low to high. The INT output signal is activated in response to interrupt generation. [Table 13](#) shows interrupt enable register bit settings.

Table 13. Interrupt Enable Register (IER) Bit Settings⁽¹⁾

BIT	BIT SETTINGS
0	0 = Disable the RHR interrupt 1 = Enable the RHR interrupt
1	0 = Disable the THR interrupt 1 = Enable the THR interrupt
2	0 = Disable the receiver line status interrupt 1 = Enable the receiver line status interrupt
3	0 = Disable the modem status register interrupt 1 = Enable the modem status register interrupt
4	0 = Disable sleep mode 1 = Enable sleep mode
5	0 = Disable the Xoff interrupt 1 = Enable the Xoff interrupt
6	0 = Disable the $\overline{\text{RTS}}$ interrupt 1 = Enable the $\overline{\text{RTS}}$ interrupt
7	0 = Disable the $\overline{\text{CTS}}$ interrupt 1 = Enable the $\overline{\text{CTS}}$ interrupt

- (1) IER[7:4] can be modified only if EFR[4] is set, that is, EFR[4] is a write enable. Re-enabling IER[1] causes a new interrupt, if the THR is below the threshold.

8.5.10 Interrupt Identification Register (IIR)

The IIR is a read-only 8-bit register, which provides the source of the interrupt in a prioritized manner. [Table 14](#) shows interrupt identification register bit settings.

Table 14. IIR Bit Settings

BIT	BIT SETTINGS
0	0 = An interrupt is pending 1 = No interrupt is pending
3:1	3-Bit encoded interrupt. See Table 13
4	1 = Xoff or special character has been detected
5	$\overline{\text{CTS/RTS}}$ low to high change of state
7:6	Mirror the contents of FCR[0]

The interrupt priority list is illustrated in [Table 15](#).

Table 15. Interrupt Priority List

PRIORITY LEVEL	BIT 5	BIT 4	BIT 3	BIT 2	BIT 1	BIT 0	INTERRUPT SOURCE
1	0	0	0	1	1	0	Receiver line status error
2	0	0	1	1	0	0	Receiver timeout interrupt
2	0	0	0	1	0	0	RHR interrupt
3	0	0	0	0	1	0	THR interrupt
4	0	0	1	0	0	0	Modem interrupt
5	0	1	0	0	0	0	Received Xoff signal or special character
6	1	0	0	0	0	0	$\overline{\text{CTS}}$, $\overline{\text{RTS}}$ change of state from active (low) to inactive (high)

8.5.11 Enhanced Feature Register (EFR)

This 8-bit register enables or disables the enhanced features of the UART. [Table 16](#) shows the enhanced feature register bit settings.

Table 16. EFR Bit Settings

BIT	BIT SETTINGS
3:0	Combinations of software flow control can be selected by programming bit 3 to bit 0. See Table 1 .
4	Enhanced functions enable bit. 0 = Disables enhanced functions and writing to IER[7:4], FCR[5:4], MCR[7:5] 1 = Enables the enhanced function IER[7:4], FCR[5:4], and MCR[7:5] can be modified, that is, this bit is therefore a write enable
5	0 = Normal operation 1 = Special character detect. Received data is compared with Xoff-2 data. If a match occurs, the received data is transferred to FIFO and IIR[4] is set to 1 to indicate a special character has been detected.
6	$\overline{\text{RTS}}$ flow control enable bit 0 = Normal operation 1 = $\overline{\text{RTS}}$ flow control is enabled, that is, $\overline{\text{RTS}}$ pin goes high when the receiver FIFO HALT trigger level TCR[3:0] is reached, and goes low when the receiver FIFO RESTORE transmission trigger level TCR[7:4] is reached.
7	$\overline{\text{CTS}}$ flow control enable bit 0 = Normal operation 1 = $\overline{\text{CTS}}$ flow control is enabled, that is, transmission is halted when a high signal is detected on the $\overline{\text{CTS}}$ pin

8.5.12 Divisor Latches (DLL, DLH)

Two 8-bit registers store the 16-bit divisor for generation of the baud clock in the baud rate generator. DLH, stores the most significant part of the divisor. DLL stores the least significant part of the division.

DLL and DLH can only be written to before sleep mode is enabled (that is, before IER[4] is set).

8.5.13 Transmission Control Register (TCR)

This 8-bit register is used to store the receive FIFO threshold levels to start or stop transmission during hardware or software flow control. [Table 17](#) shows transmission control register bit settings.

Table 17. TCR Bit Settings

BIT	BIT SETTINGS
3:0	RCV FIFO trigger level to HALT transmission (0 to 60)
7:4	RCV FIFO trigger level to RESTORE transmission (0 to 60)

TCR trigger levels are available from 0 to 60 bytes with a granularity of four.

TCR can be written to only when EFR[4] = 1 and MCR[6] = 1. The programmer must program the TCR such that TCR[3:0] > TCR[7:4]. There is no built-in hardware check to make sure this condition is met. Also, the TCR must be programmed with this condition before Auto-RTS or software flow control is enabled to avoid spurious operation of the device.

8.5.14 Trigger Level Register (TLR)

This 8-bit register is used to store the transmit and received FIFO trigger levels used for DMA and interrupt generation. Trigger levels from 4 to 60 can be programmed with a granularity of 4. [Table 18](#) shows trigger level register bit settings.

Table 18. TLR Bit Settings

BIT	BIT SETTINGS
3:0	Transmit FIFO trigger levels (4 to 60), number of spaces available
7:4	RCV FIFO trigger levels (4 to 60), number of characters available

TLR can be written to only when EFR[4] = 1 and MCR[6] = 1. If TLR[3:0] or TLR[7:4] are 0, then the selectable trigger levels via the FIFO control register (FCR) are used for the transmit and receive FIFO trigger levels. Trigger levels from 4 to 60 bytes are available with a granularity of 4. The TLR should be programmed for $N / 4$, where N is the desired trigger level.

8.5.15 FIFO Ready Register

The FIFO ready register provides realtime status of the transmit and receive FIFOs of both channels. Table 19 shows the FIFO ready register bit settings. The trigger level mentioned in Table 19 refers to the setting in either FCR (when TLR value is 0), or TLR (when it has a nonzero value).

Table 19. FIFO Ready Register

BIT	BIT SETTINGS
0	0 = There are fewer than a TX trigger level number of spaces available in the TX FIFO of channel A. 1 = There are at least a TX trigger level number of spaces available in the TX FIFO of channel A.
1	0 = There are fewer than a TX trigger level number of spaces available in the TX FIFO of channel B. 1 = There are at least a TX trigger level number of spaces available in the TX FIFO of channel B.
3:2	Unused, always 0
4	0 = There are fewer than a RX trigger level number of characters in the RX FIFO of channel A. 1 = The RX FIFO of channel A has more than a RX trigger level number of characters available for reading or a timeout condition has occurred.
5	0 = There are fewer than a RX trigger level number of characters in the RX FIFO of channel B. 1 = The RX FIFO of channel B has more than a RX trigger level number of characters available for reading or a timeout condition has occurred.
7:6	Unused, always 0

The FIFORdy register is a read only register and can be accessed when any of the two UARTs are selected. CSA or CSB = 0, MCR[2] (FIFORdy Enable) is a logic 1, and loopback is disabled. Its address is 111.

8.5.16 Alternate Function Register (AFR)

The AFR is used to enable some extra functionality beyond the capabilities of the original TL16C752B. The first of these is a concurrent write mode, which can be useful in more expediently setting up all four UART channels. The second addition is the IrDA mode, which supports Standard IrDA (SIR) mode with baud rates from 2400 to 115.2 bps. The third addition is support for RS-485 bus drivers or transceivers by providing an output pin ($\overline{\text{DTRx}}$) per channel, which is timed to keep the RS-485 driver enabled as long as transmit data is pending.

The AFR is located at A[2:0] = 010 when LCR[7:5] = 100.

Table 20. AFR Bit Settings

BIT	BIT SETTINGS
0	CONC enables the concurrent write of all four (754) or two (752) channels simultaneously, which helps speed up initialization. Ensure that any indirect addressing modes have been enabled before using.
1	IREN enables the IrDA SIR mode. This mode is only specified to 115.2 bps; TI does not recommend the use of this mode at higher speeds.
2	485EN enables the half duplex RS-485 mode and causes the $\overline{\text{DTRx}}$ output to be set high whenever there is any data in the THR or TSR and to be held high until the delay set by DLY2:0 has expired, at which time it is set low. The $\overline{\text{DTRx}}$ output is intended to drive the enabled input of an RS-485 driver. When this bit is set, the transmitter interrupts are held off until the TSR is empty, unless 485LG is set.
3	485LG is set when the 485EN is set. This bit indicates that a relatively large data block is being set, requiring more than a single load of the xmt fifo. In this case, the transmitter interrupts occur as in the standard RS-232 mode, either when the xmt fifo contents drop below the xmt threshold or when the xmt fifo is empty.
4	RCVEN is valid only when 485EN or IREN is set, and allows the serial receiver to listen in or snoop on the RS485 traffic or IrDA traffic. RS485 mode is generally considered half duplex, and usually a node is either driving or receiving, but there can be cases when it is advantageous to verify what you are sending. This can be used to detect collisions or as part of an arbitration mechanism on the bus. When both RCVEN and 485EN are set, the receiver stores any data presented on RX, if any. Note that implies that the external RS485 receiver is enabled. Whenever 485EN is cleared, the serial receiver is enabled for normal full duplex RS232 traffic. If RCVEN is cleared while 485EN is set, the receiver is disabled while that channel is transmitting. SIR is also considered half duplex. Often the light energy from the transmitting LED is coupled back into the receiving PIN diode, which creates an input data stream that is not of interest to the host. Disabling the receiver (clearing RCVEN) prevents this reception, and eliminates the task of unloading the data. On the other hand, for diagnostic or other purposes, it may be useful to observe this data stream. For example, a mirror could be used to intentionally couple the output LED to the input PIN. For these cases, RCVEN could be set to enable the receiver. NOTE: When RCVEN is cleared (set to 0), the character timeout interrupt is not available, even in RSA-232 mode. This can be useful when checking code for valid threshold interrupts, as the timeout interrupt will not override the threshold interrupt.

Table 20. AFR Bit Settings (continued)

BIT	BIT SETTINGS
7:5	DLY2 to DLY0 sets a delay after the last stop bit of the last data byte being set before the $\overline{\text{DTRx}}$ is set low, to allow for long cable runs. The delay is in number of bit times and is enabled by 485EN. The delay starts only when both the xmt serial shift register (TSR) is empty and the xmt fifo (THR) is empty, and if started, will be cleared by any data being written to the THR.

Table 21. LOOP and RCVEN Functionality

LOOP MODE	RCVEN	AFR	MODE	DESCRIPTION
LOOP mode off, MCR4 = 0, RX, TX active	RCVEN = 1	AFR = 10	RS-232	Receive threshold, timeout, and error detection interrupts available Data stored in receive FIFO
		AFR = 14	RS-485	Receive threshold, timeout, and error detection interrupts available Data stored in receive FIFO
		AFR = 12	IrDA	Receive threshold, timeout, and error detection interrupts available Data stored in receive FIFO
	RCVEN = 0	AFR = 00	RS-232	Receive threshold and error detection interrupts available Data stored in receive FIFO
		AFR = 04	RS-485	No data stored in receive FIFO, hence no interrupts available
		AFR = 02	IrDA	No data stored in receive FIFO, hence no interrupts available
LOOP mode on, MCR4 = 1, RX, TX inactive	RCVEN = 1	AFR = 10	RS-232	Receive threshold, timeout, and error detection interrupts available Data stored in receive FIFO
		AFR = 14	RS-485	Receive threshold, timeout, and error detection interrupts available Data stored in receive FIFO
		AFR = 12	IrDA	Receive threshold, timeout, and error detection interrupts available Data stored in receive FIFO
	RCVEN = 0	AFR = 00	RS-232	Receive threshold and error detection interrupts available Data stored in receive FIFO
		AFR = 04	RS-485	Receive threshold and error detection interrupts available Data stored in receive FIFO
		AFR = 02	IrDA	Receive threshold and error detection interrupts available Data stored in receive FIFO

8.5.17 RS-485 Mode

The RS-485 mode is intended to simplify the interface between the UART channel and an RS-485 driver or transceiver. When enabled by setting 485EN, the $\overline{\text{DTRx}}$ output goes high one bit time before the first stop bit of the first data byte being sent, and remains high as long as there is pending data in the TSR or THR (xmt fifo). After both are empty (after the last stop bit of the last data byte), the $\overline{\text{DTRx}}$ output stays high for a programmable delay of 0 to 15 bit times, as set by DLY[2:0]. This helps preserve data integrity over long signal lines. This is illustrated in the following.

Often RS-485 packets are relatively short and the entire packet can fit within the 64 byte xmt fifo. In this case, it goes empty when the TSR goes empty. But in cases where a larger block needs to be sent, it is advantageous to reload the xmt fifo as soon as it is depleted. Otherwise, the transmission stalls while waiting for the xmt fifo to be reloaded, which varies with processor load. In this case, it is best to also set 485LG (large block), which causes the transmit interrupt to occur wither when the THR becomes empty (if the xmt fifo level was not above the threshold), or when the xmt fifo threshold is crossed. The reloading of the xmt fifo occurs while some data is being shifted out, eliminating fifo underrun. If desired, when the last bytes of a current transmission are being loaded in the xmt fifo, 485LG can be cleared before the load and the transmit interrupt occurs on the TSR going empty.

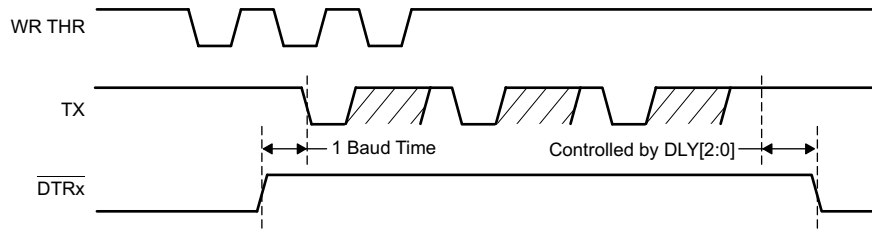

A. Waveforms are not shown to scale, as the WR THR pulses typically are less than 100 ns, where the TX waveform varies with baud rate but is typically in the microsecond range.

Figure 27. $\overline{\text{DTRx}}$ and Transmit Data Relationship

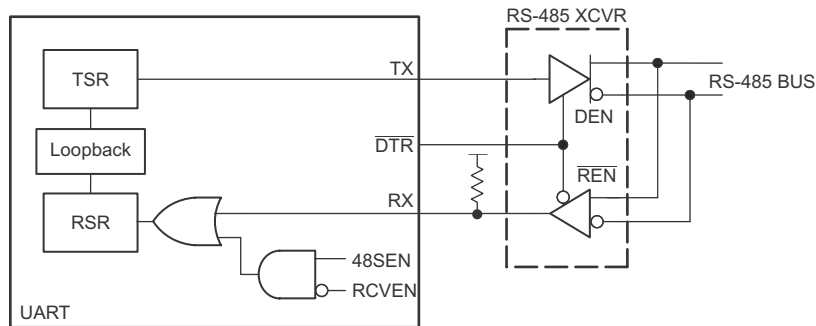

Figure 28. RS-485 Application Example 1

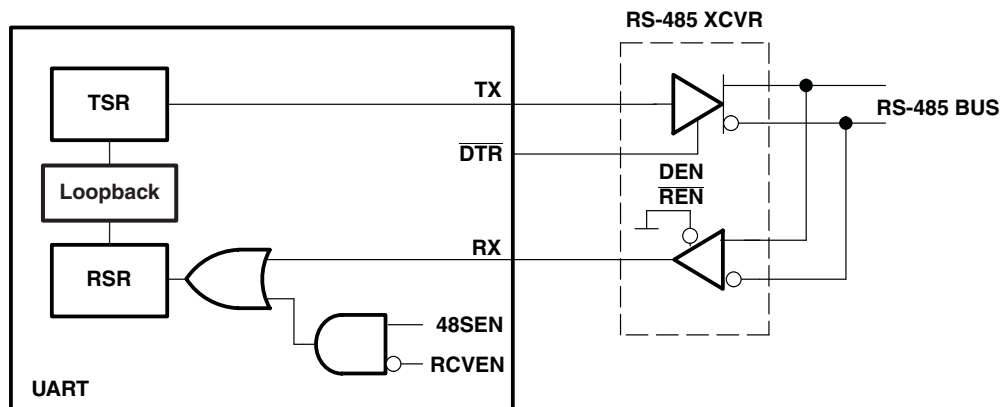

Figure 29. RS-485 Application Example 2

8.5.18 IrDA Overview

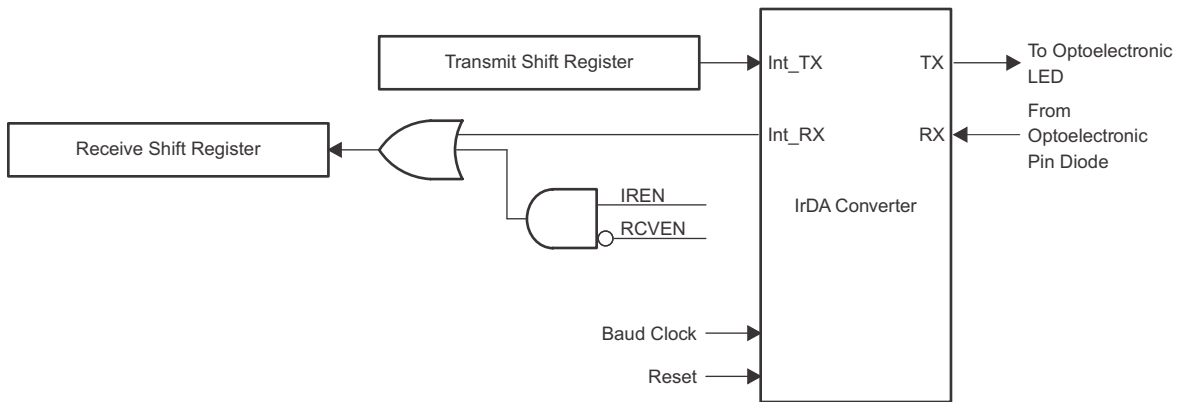

Figure 30. IrDA Mode

The IrDA defines several protocols for sending and receiving serial infrared data, including rates of 115.2 kbps, 0.576 Mbps, 1.152 Mbps, and 4 Mbps. The low rate of 115.2 kbps was specified first and the others must maintain downward compatibility with it. At the 115.2 kbps rate, the protocol implemented in the hardware is fairly simple. It primarily defines a serial infrared data word to be surrounded by a start bit equal to 0 and a stop bit equal to 1. Individual bits are encoded or decoded the same whether they are start, data, or stop bits. The IrDA engine in the TL16C752CI-Q1 device only evaluates single bits and follows the 115.2-kbps protocol. The 115.2-kbps rate is a maximum rate. When both ends of the transfer are setup to a lower but matching speed, the protocol still works. The clock used to code or sample the data is 16 times the baud rate, or 1.843-MHz maximum. To code a 1, no pulse is sent or received for 1-bit time period, or 16 clock cycles. To code a 0, one pulse is sent or received within a 1-bit time period, or 16 clock cycles. The pulse must be at least 1.6- μ s wide and 3 clock cycles long at 1.843 MHz. At lower baud rates the pulse can be 1.6 μ s wide or as long as 3 clock cycles. The transmitter output, TX, is intended to drive a LED circuit to generate an infrared pulse. The LED circuits work on positive pulses. A terminal circuit is expected to create the receiver input, RX. Most, but not all, PIN circuits have inversion and generate negative pulses from the detected infrared light. Their output is normally high. The TL16C752CI-Q1 device can decode either negative or positive pulses on RX.

8.5.19 IrDA Encoder Function

Serial data from a UART is encoded to transmit data to the optoelectronics. While the serial data input to this block (Int_TX) is high, the output (TX) is always low, and the counter used to form a pulse on TX is continuously cleared. After Int_TX resets to 0, TX rises on the falling edge of the 7th 16XCLK. On the falling edge of the 10th 16XCLK pulse, TX falls, creating a 3-clock-wide pulse. While Int_TX stays low, a pulse is transmitted during the seventh to tenth clocks of each 16-clock bit cycle.

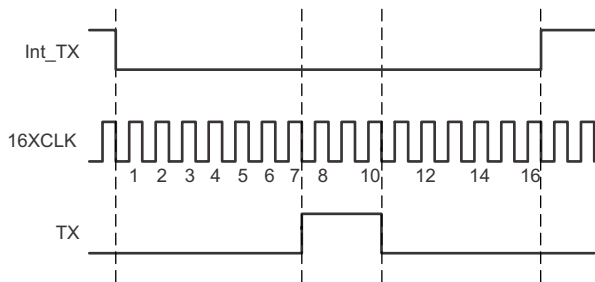

Figure 31. IrDA-SIR Encoding Scheme – Detailed Timing Diagram

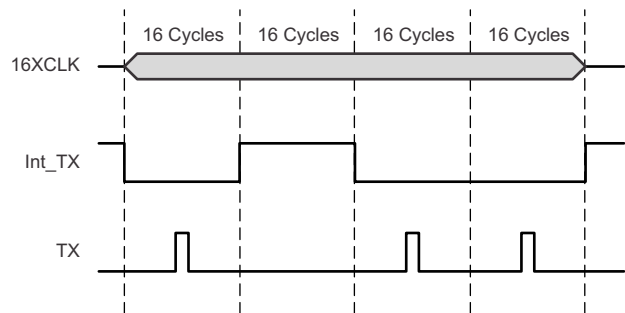

Figure 32. Encoding Scheme – Macro View

After reset, Int_RX is high and the 4-bit counter is cleared. When a falling edge is detected on RX, Int_RX falls on the next rising edge of 16XCLK with sufficient setup time. Int_RX stays low for 16 cycles (16XCLK) and then returns to high as required by the IrDA specification. As long as no pulses (falling edges) are detected on RX, Int_RX remains high.

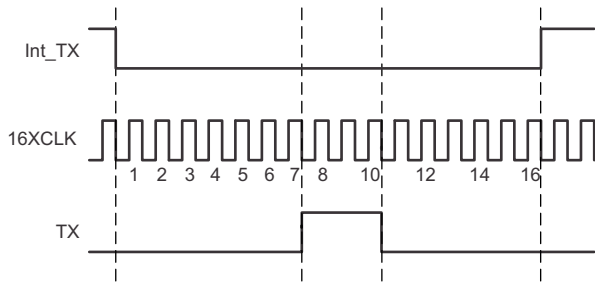

Figure 33. IrDA-SIR Decoding Scheme – Detailed Timing Diagram

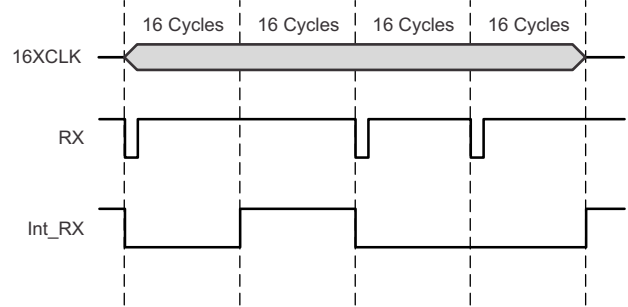

Figure 34. IrDA-SIR Decoding Scheme – Macro View

It is possible for jitter or slight frequency differences to cause the next falling edge on RX to be missed for one 16XCLK cycle. In that case, a 1-clock-wide pulse appears on Int_RX between consecutive 0s. It is important for the UART to strobe Int_RX in the middle of the bit time to avoid latching this 1-clock-wide pulse. The TL16C550C UART already strobes incoming serial data at the proper time. Otherwise, note that data is required to be framed by a leading 0 and a trailing 1. The falling edge of that first 0 on Int_RX synchronizes the read strobe. The strobe occurs on the 8th 16XCLK pulse after the Int_RX falling edge and once every 16 cycles thereafter until the stop bit occurs.

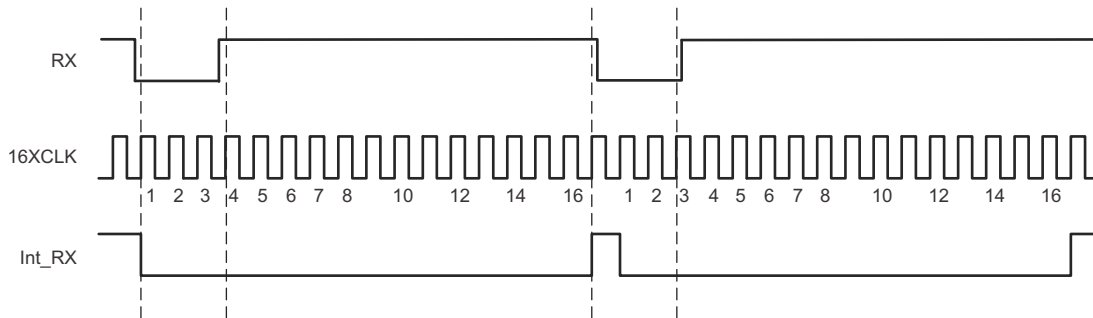

Figure 35. Timing Causing 1-Clock-Wide Pulse Between Consecutive Ones

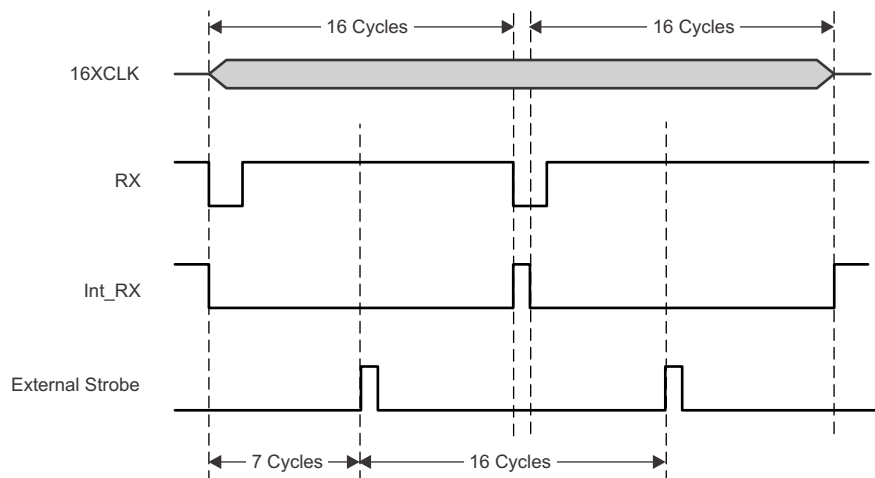

Figure 36. Recommended Strobing for Decoded Data

The TL16C752CI-Q1 device can decode positive pulses on RX. The timing is different, but the variation is invisible to the UART. The decoder, which works from the falling edge, now recognizes a 0 on the trailing edge of the pulse rather than on the leading edge. As long as the pulse duration is fairly constant, as defined by the specification, the trailing edges should also be 16 clock cycles apart and data can readily be decoded. The 0 appears on Int_RX after the pulse rather than at the start of it.

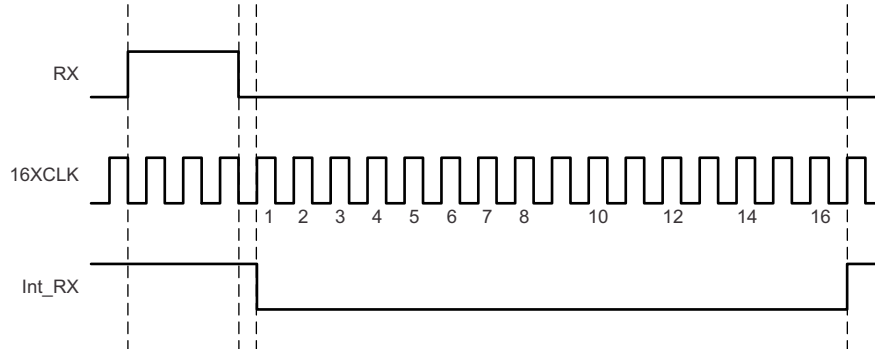

Figure 37. Positive RX Pulse Decode – Detailed View

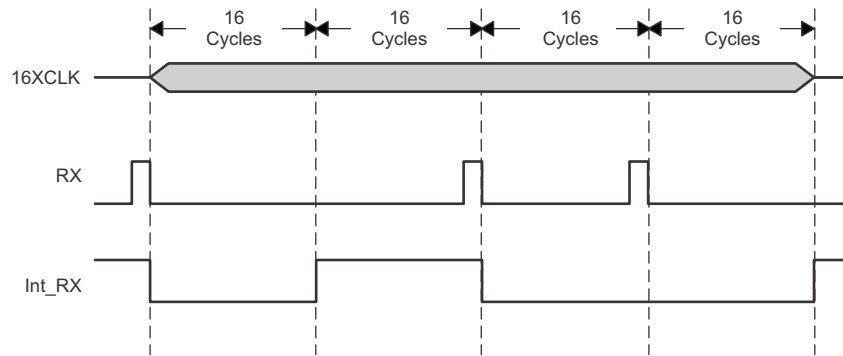

Figure 38. Positive RX Pulse Decode – Macro View

9 Application and Implementation

NOTE

Information in the following applications sections is not part of the TI component specification, and TI does not warrant its accuracy or completeness. TI's customers are responsible for determining suitability of components for their purposes. Customers should validate and test their design implementation to confirm system functionality.

9.1 Application Information

The typical implementation is to use the TL16C752CI-Q1 as a dual RS-232 interface, which is intended to operate with a 5-V microprocessor.

9.2 Typical Application

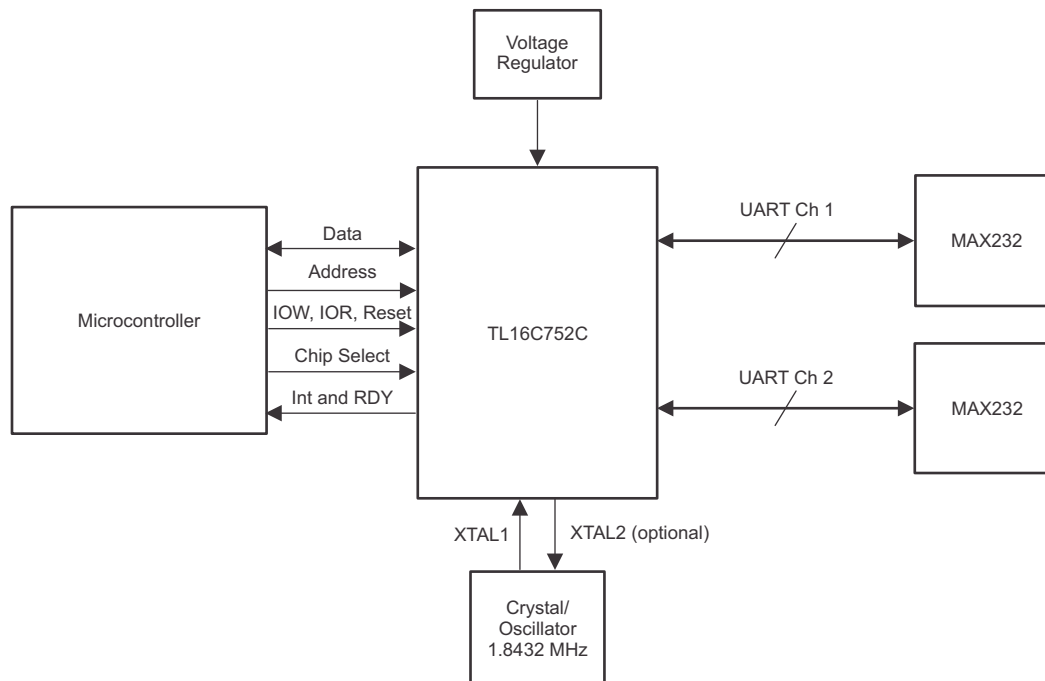

Figure 39. Typical Application Dual RS-232 Interface

9.2.1 Design Requirements

Include the recommended operating conditions for 3.3 V provided by the controller board, but with the input clock equal to 1.8432 MHz, and include the Operating free-air temperature conditions. The controller must have two 8-bit ports, one for the control signals and another for the I/O data. A third port is optional to monitor the interruptions and TX/RX ready signals (if it is needed).

9.2.2 Detailed Design Procedure

1. Implement the schematic as is shown in [Figure 39](#).
2. Implement on the controller the READ and WRITE routines to meet the timing requirements of the [Timing Requirements](#), use [Figure 1](#) and [Figure 2](#) as a guideline.
3. Initialize all the configuration registers. TI recommends not to obviate the default settings and initialize all of the set of configuration registers. The base set of registers that are used during high-speed data transfer have a straightforward access method. The extended function registers require special access bits to be decoded along with the address lines. The following guide helps with programming these registers. Note that the descriptions are for individual register access. Some streamlining through interleaving can be obtained when programming all the registers.

Typical Application (continued)

- Set baud rate to VALUE1, VALUE2 Read LCR (03), save in temp Set LCR (03) to 80 Set DLL (00) to VALUE1 Set DLM (01) to VALUE2 Set LCR (03) to temp
- Set Xoff1, Xon1 to VALUE1, VALUE2 Read LCR (03), save in temp Set LCR (03) to BF Set Xoff1 (06) to VALUE1 Set Xon1 (04) to VALUE2 Set LCR (03) to temp
- Set Xoff2, Xon2 to VALUE1, VALUE2 Read LCR (03), save in temp Set LCR (03) to BF Set Xoff2 (07) to VALUE1 Set Xon2 (05) to VALUE2 Set LCR (03) to temp
- Set software flow control mode to VALUE Read LCR (03), save in temp Set LCR (03) to BF Set EFR (02) to VALUE Set LCR (03) to temp
- Set flow control threshold to VALUE Read LCR (03), save in temp1 Set LCR (03) to BF Read EFR (02), save in temp2 Set EFR (02) to 10 + temp2 Set LCR (03) to 00 Read MCR (04), save in temp3 Set MCR (04) to 40 + temp3 Set TCR (06) to VALUE Set LCR (03) to BF Set EFR (02) to temp2 Set LCR (03) to temp1 Set MCR (04) to temp3
- Set xmt and rcv FIFO thresholds to VALUE Read LCR (03), save in temp1 Set LCR (03) to BF Read EFR (02), save in temp2 Set EFR (02) to 10 + temp2 Set LCR (03) to 00 Read MCR (04), save in temp3 Set MCR (04) to 40 + temp3 Set TLR (07) to VALUE Set LCR (03) to BF Set EFR (02) to temp2 Set LCR (03) to temp1 Set MCR (04) to temp3
- Read FIFORdy register Read MCR (04), save in temp1 Set temp2 = temp1 × EF Set MCR (04), save in temp2 Read FRR (07), save in temp2 Pass temp2 back to host Set MCR (04) to temp1

The designer can use [Figure 39](#) as a guideline to configure each channel of the UART.

9.2.3 Application Curves

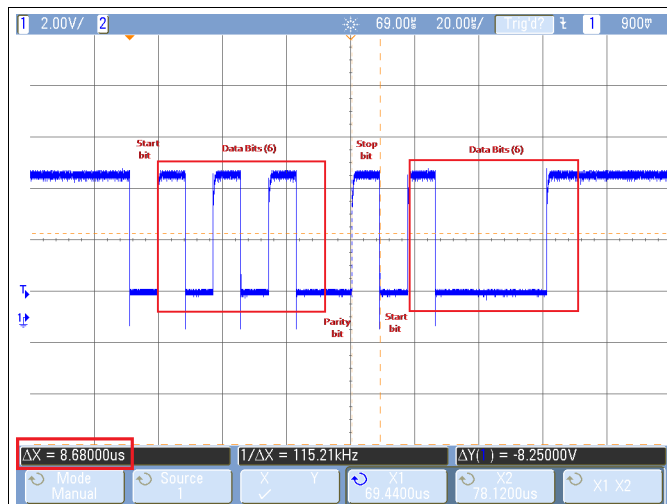

Figure 40. Typical Two Bytes Transmission With 6 Bits of Data (0x15 and 0x21), Odd Parity and One Stop Bit

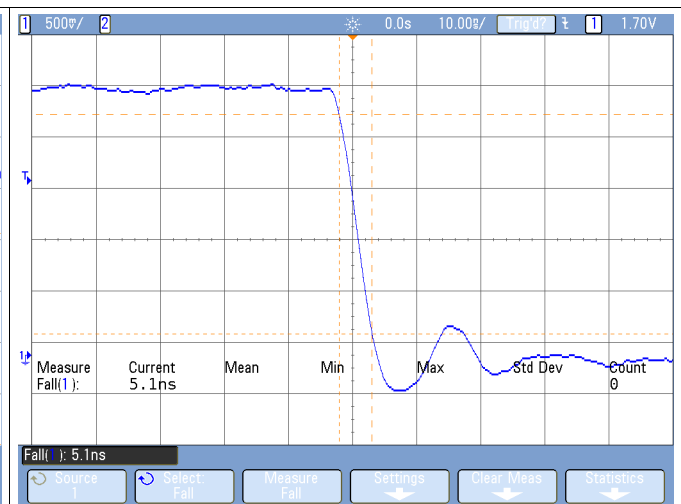

Figure 41. Typical Fall Time

Typical Application (continued)

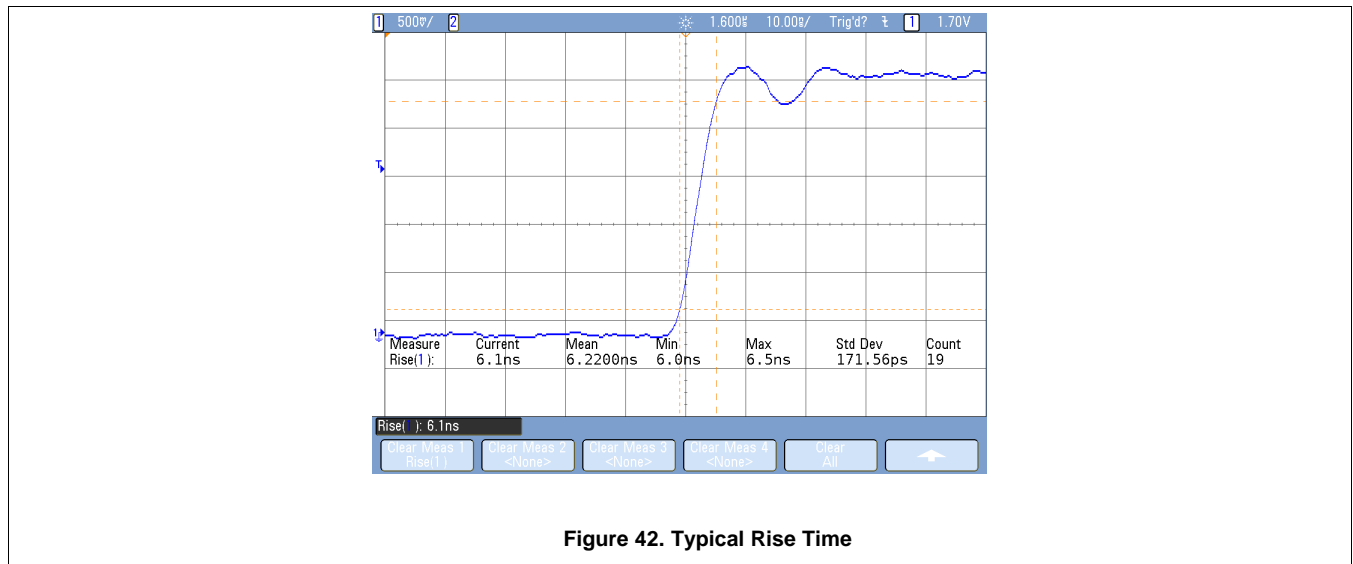

Figure 42. Typical Rise Time

10 Power Supply Recommendations

The power supply must provide a constant voltage with a 10% maximum variation of the nominal value and has to be able to provide at least the maximum current consumption of the device for the selected nominal voltage only for the UART device:

- 4.5 mA for $V_{CC} = 1.8\text{ V}$
- 9 mA for $V_{CC} = 2.5\text{ V}$
- 16 mA for $V_{CC} = 3.3\text{ V}$
- 40 mA for $V_{CC} = 5\text{ V}$

The VCC pin must have a 1- μF bypass capacitor placed as close as possible to this pin. Also, TI recommends to include two extra capacitors in parallel, which should also be placed as close as possible to the VCC pin. The suggested values for these extra capacitors are 0.1 μF and 0.01 μF , respectively.

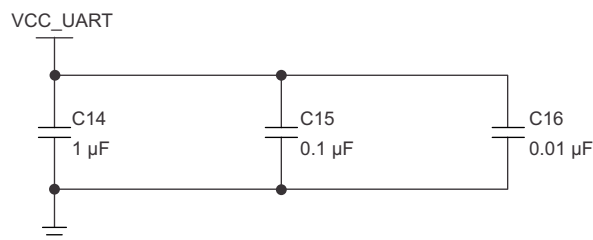

Place as close as possible to the VCC pin of the UART.

Figure 43. Recommended Bypass Capacitors Array

11 Layout

11.1 Layout Guidelines

Traces, Vias, and Other PCB Components: A right angle in a trace can cause more radiation. The capacitance increases in the region of the corner, and the characteristic impedance changes. This impedance change causes reflections.

- Avoid right-angle bends in a trace and try to route them at least with two 45° corners. To minimize any impedance change, the best routing would be a round bend (see [Figure 24](#)).
- Separate high-speed signals (for example, clock signals) from low-speed signals and digital from analog signals; again, placement is important.
- To minimize crosstalk not only between two signals on one layer but also between adjacent layers, route them with 90° to each other

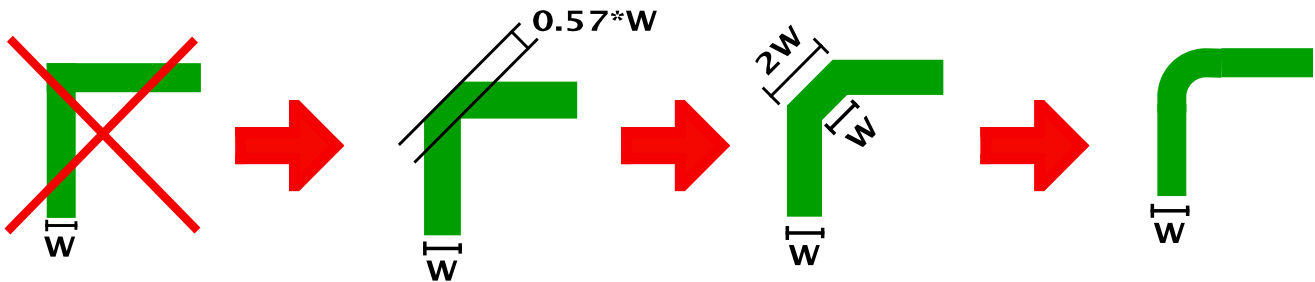

Figure 44. Layout Do's and Don'ts

11.2 Layout Example

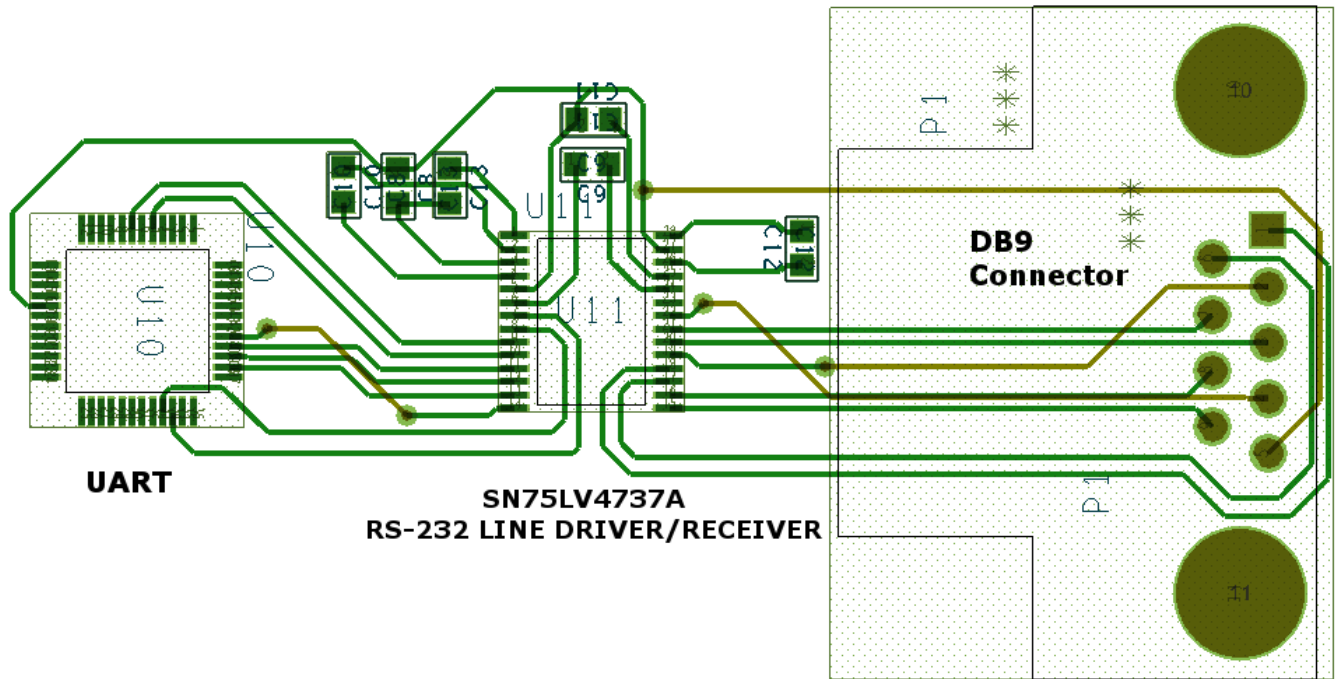

Figure 45. RS232 Channel Layout Example

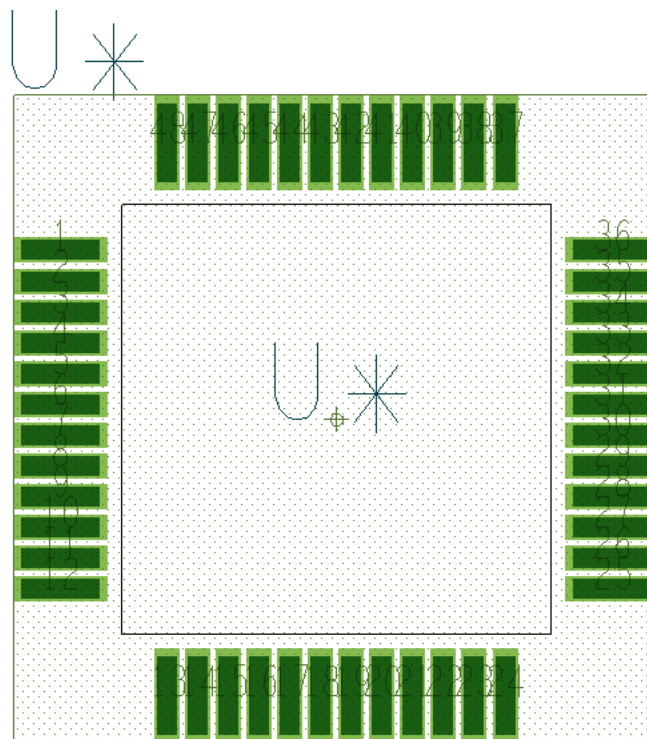

Figure 46. Footprint Example

12 器件和文档支持

12.1 社区资源

The following links connect to TI community resources. Linked contents are provided "AS IS" by the respective contributors. They do not constitute TI specifications and do not necessarily reflect TI's views; see TI's [Terms of Use](#).

TI E2E™ Online Community *TI's Engineer-to-Engineer (E2E) Community*. Created to foster collaboration among engineers. At e2e.ti.com, you can ask questions, share knowledge, explore ideas and help solve problems with fellow engineers.

Design Support *TI's Design Support* Quickly find helpful E2E forums along with design support tools and contact information for technical support.

12.2 商标

E2E is a trademark of Texas Instruments.
All other trademarks are the property of their respective owners.

12.3 静电放电警告



这些装置包含有限的内置 ESD 保护。存储或装卸时，应将导线一起截短或将装置放置于导电泡棉中，以防止 MOS 门极遭受静电损伤。

12.4 Glossary

[SLYZ022](#) — *TI Glossary*.

This glossary lists and explains terms, acronyms, and definitions.

13 机械、封装和可订购信息

以下页面包括机械、封装和可订购信息。这些信息是指定器件的最新可用数据。这些数据发生变化时，我们可能不会另行通知或修订此文档。如欲获取此产品说明书的浏览器版本，请参见左侧的导航栏。

PACKAGING INFORMATION

Orderable Device	Status (1)	Package Type	Package Drawing	Pins	Package Qty	Eco Plan (2)	Lead finish/ Ball material (6)	MSL Peak Temp (3)	Op Temp (°C)	Device Marking (4/5)	Samples
TL16C752CIPFBRQ1	ACTIVE	TQFP	PFB	48	1000	RoHS & Green	NIPDAU	Level-2-260C-1 YEAR	-40 to 105	T16C752DQ	Samples

(1) The marketing status values are defined as follows:

ACTIVE: Product device recommended for new designs.

LIFEBUY: TI has announced that the device will be discontinued, and a lifetime-buy period is in effect.

NRND: Not recommended for new designs. Device is in production to support existing customers, but TI does not recommend using this part in a new design.

PREVIEW: Device has been announced but is not in production. Samples may or may not be available.

OBSELETE: TI has discontinued the production of the device.

(2) **RoHS:** TI defines "RoHS" to mean semiconductor products that are compliant with the current EU RoHS requirements for all 10 RoHS substances, including the requirement that RoHS substance do not exceed 0.1% by weight in homogeneous materials. Where designed to be soldered at high temperatures, "RoHS" products are suitable for use in specified lead-free processes. TI may reference these types of products as "Pb-Free".

RoHS Exempt: TI defines "RoHS Exempt" to mean products that contain lead but are compliant with EU RoHS pursuant to a specific EU RoHS exemption.

Green: TI defines "Green" to mean the content of Chlorine (Cl) and Bromine (Br) based flame retardants meet JS709B low halogen requirements of <=1000ppm threshold. Antimony trioxide based flame retardants must also meet the <=1000ppm threshold requirement.

(3) MSL, Peak Temp. - The Moisture Sensitivity Level rating according to the JEDEC industry standard classifications, and peak solder temperature.

(4) There may be additional marking, which relates to the logo, the lot trace code information, or the environmental category on the device.

(5) Multiple Device Markings will be inside parentheses. Only one Device Marking contained in parentheses and separated by a "-" will appear on a device. If a line is indented then it is a continuation of the previous line and the two combined represent the entire Device Marking for that device.

(6) Lead finish/Ball material - Orderable Devices may have multiple material finish options. Finish options are separated by a vertical ruled line. Lead finish/Ball material values may wrap to two lines if the finish value exceeds the maximum column width.

Important Information and Disclaimer:The information provided on this page represents TI's knowledge and belief as of the date that it is provided. TI bases its knowledge and belief on information provided by third parties, and makes no representation or warranty as to the accuracy of such information. Efforts are underway to better integrate information from third parties. TI has taken and continues to take reasonable steps to provide representative and accurate information but may not have conducted destructive testing or chemical analysis on incoming materials and chemicals. TI and TI suppliers consider certain information to be proprietary, and thus CAS numbers and other limited information may not be available for release.

In no event shall TI's liability arising out of such information exceed the total purchase price of the TI part(s) at issue in this document sold by TI to Customer on an annual basis.

TAPE AND REEL INFORMATION

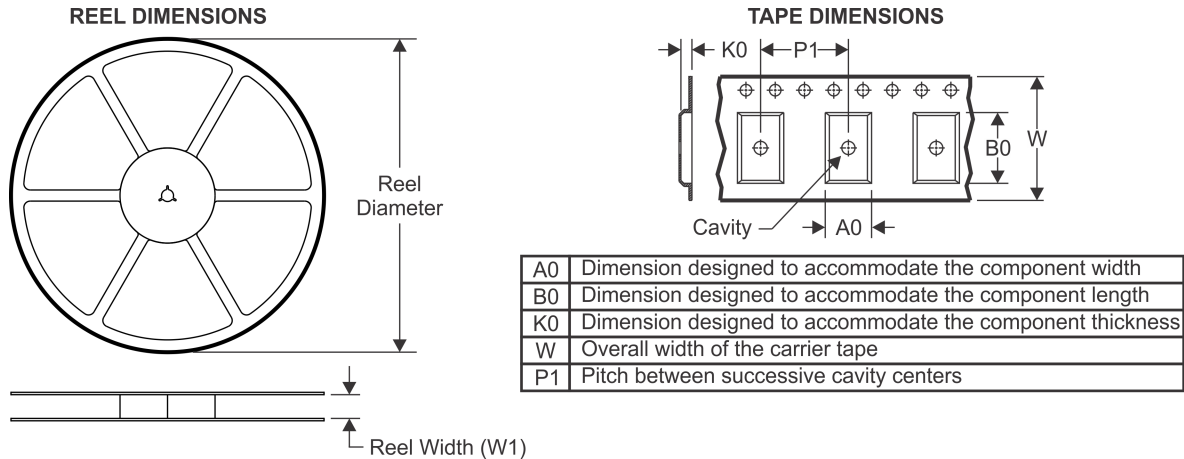

QUADRANT ASSIGNMENTS FOR PIN 1 ORIENTATION IN TAPE



*All dimensions are nominal

Device	Package Type	Package Drawing	Pins	SPQ	Reel Diameter (mm)	Reel Width W1 (mm)	A0 (mm)	B0 (mm)	K0 (mm)	P1 (mm)	W (mm)	Pin1 Quadrant
TL16C752CIPFBRQ1	TQFP	PFB	48	1000	330.0	16.4	9.6	9.6	1.5	12.0	16.0	Q2

TAPE AND REEL BOX DIMENSIONS

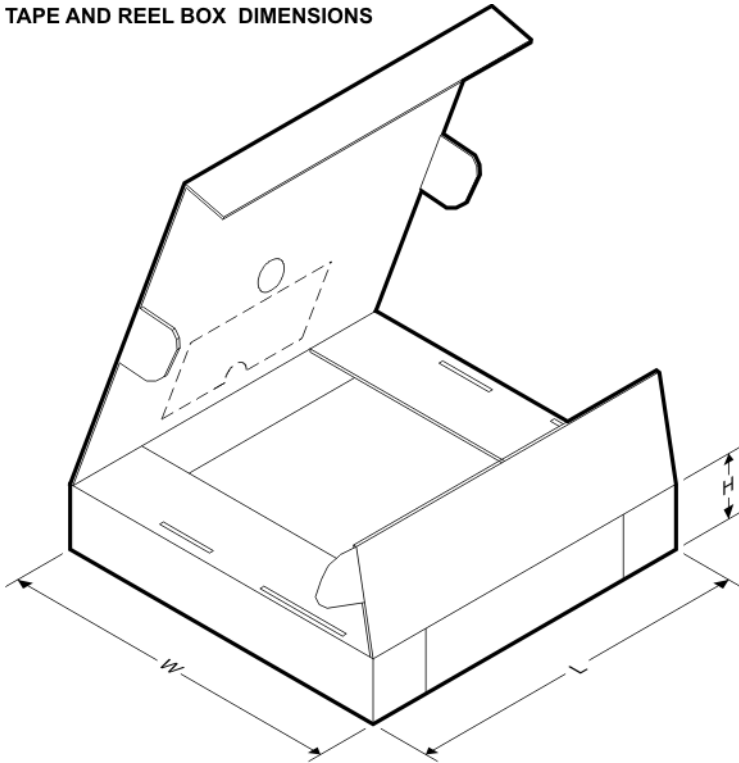

*All dimensions are nominal

Device	Package Type	Package Drawing	Pins	SPQ	Length (mm)	Width (mm)	Height (mm)
TL16C752CIPFBRQ1	TQFP	PFB	48	1000	336.6	336.6	31.8

PFB (S-PQFP-G48)

PLASTIC QUAD FLATPACK

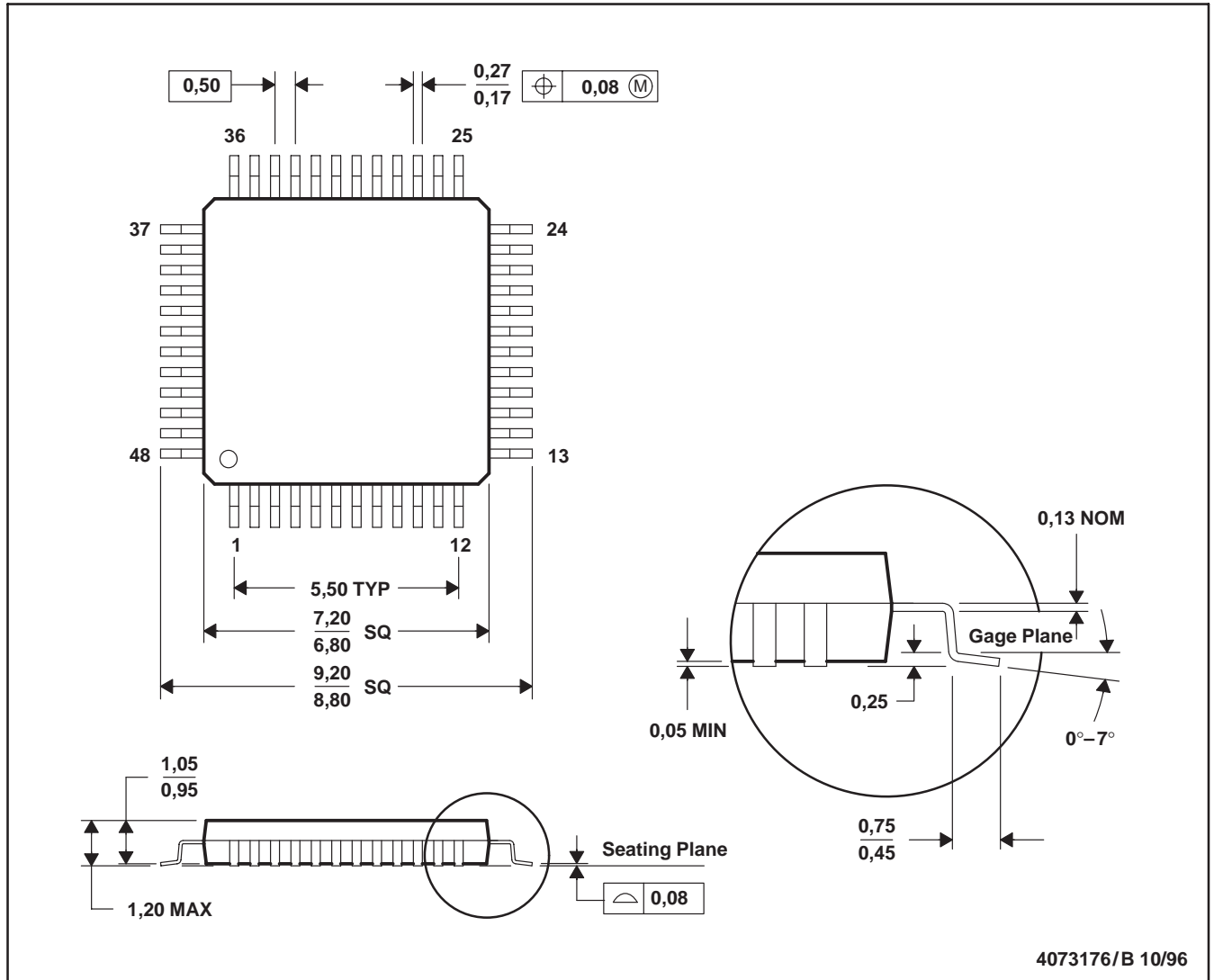

- NOTES: A. All linear dimensions are in millimeters.
 B. This drawing is subject to change without notice.
 C. Falls within JEDEC MS-026

PFB (S-PQFP-G48)

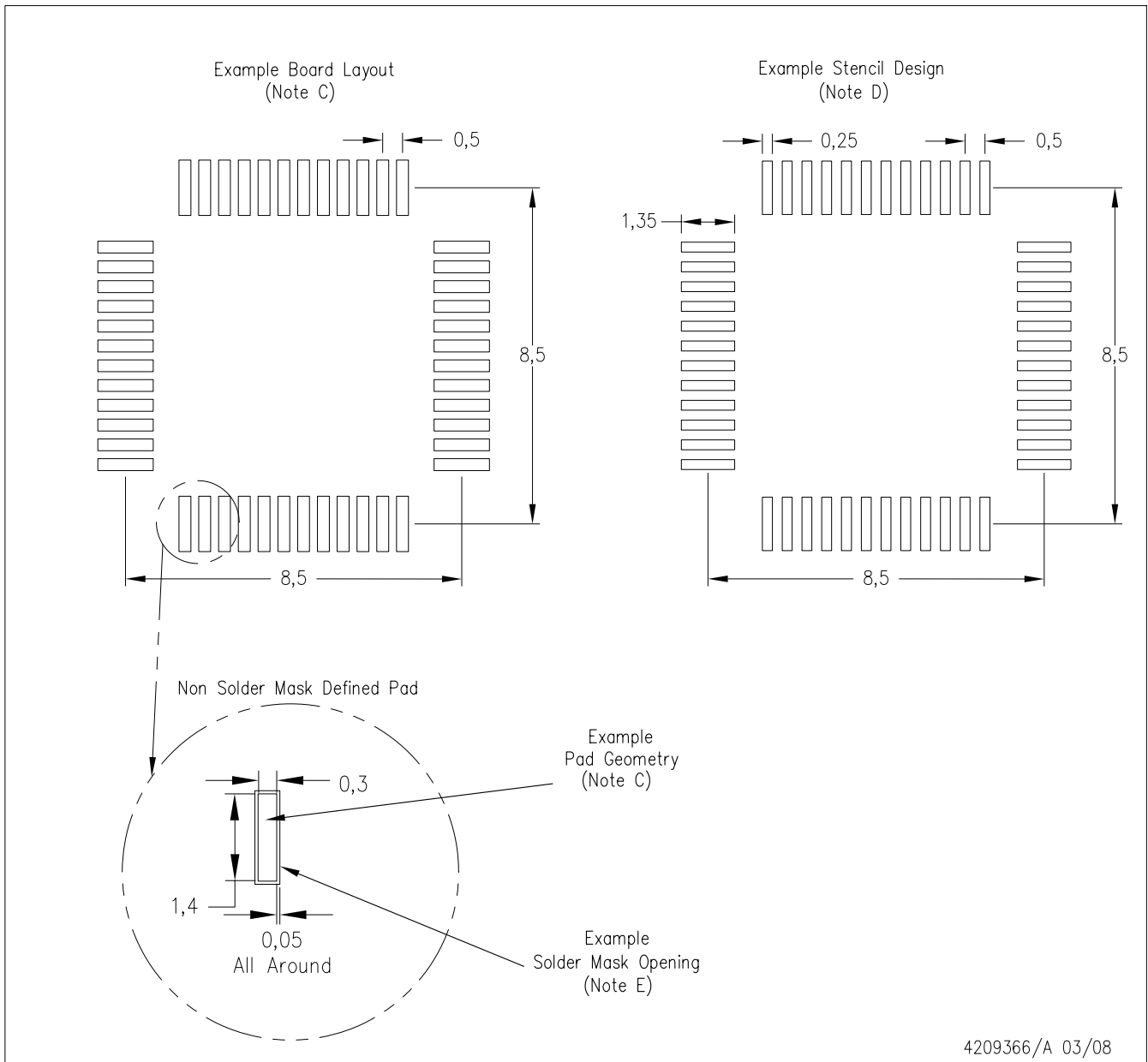

- NOTES:
- A. All linear dimensions are in millimeters.
 - B. This drawing is subject to change without notice.
 - C. Publication IPC-7351 is recommended for alternate designs.
 - D. Laser cutting apertures with trapezoidal walls and also rounding corners will offer better paste release. Customers should contact their board assembly site for stencil design recommendations. Refer to IPC-7525.
 - E. Customers should contact their board fabrication site for solder mask tolerances between and around signal pads.

重要声明和免责声明

TI 均以“原样”提供技术性及其可靠性数据（包括数据表）、设计资源（包括参考设计）、应用或其他设计建议、网络工具、安全信息和其他资源，不保证其中不含任何瑕疵，且不做任何明示或暗示的担保，包括但不限于对适销性、适合某特定用途或不侵犯任何第三方知识产权的暗示担保。

所述资源可供专业开发人员应用TI 产品进行设计使用。您将对以下行为独自承担全部责任：(1) 针对您的应用选择合适的TI 产品；(2) 设计、验证并测试您的应用；(3) 确保您的应用满足相应标准以及任何其他安全、安保或其他要求。所述资源如有变更，恕不另行通知。TI 对您使用所述资源的授权仅限于开发资源所涉及TI 产品的相关应用。除此之外不得复制或展示所述资源，也不提供其它TI 或任何第三方的知识产权授权许可。如因使用所述资源而产生任何索赔、赔偿、成本、损失及债务等，TI 对此概不负责，并且您须赔偿由此对TI 及其代表造成的损害。

TI 所提供产品均受TI 的销售条款 (<http://www.ti.com.cn/zh-cn/legal/termsofsale.html>) 以及ti.com.cn 上或随附TI 产品提供的其他可适用条款的约束。TI 提供所述资源并不扩展或以其他方式更改TI 针对TI 产品所发布的可适用的担保范围或担保免责声明。

邮寄地址：上海市浦东新区世纪大道 1568 号中建大厦 32 楼，邮政编码：200122
Copyright © 2020 德州仪器半导体技术（上海）有限公司