

# MCT8316Z 含传感器梯形集成式 FET BLDC 电机驱动器

## 1 特性

- 集成含传感器梯形控制的三相 BLDC 电机驱动器
  - 基于霍尔传感器的梯形 (120°) 换向
  - 支持模拟或数字霍尔输入
  - 可配置 PWM 调制：同步/异步
  - 逐周期电流限制，可限制相位电流
  - 支持高达 200kHz 的 PWM 频率
  - 主动消磁支持减少功率损耗
- 4.5V 至 35V 工作电压 (绝对最大值 40V)
- 高输出电流能力：8A 峰值
- 低 MOSFET 导通状态电阻
  - $T_A = 25^\circ\text{C}$  时， $R_{DS(ON)} (HS + LS)$  为  $95\text{m}\Omega$
- 低功耗睡眠模式
  - $1.5\mu\text{A}$  ( $V_{VM} = 24\text{V}$ ,  $T_A = 25^\circ\text{C}$ )
- 集成内置电流检测
  - 无需外部电流检测电阻器
- 灵活的器件配置选项
  - MCT8316ZR：用于器件配置和故障状态的 5MHz 16 位 SPI 接口
  - MCT8316ZT：基于硬件引脚的配置
- 支持 1.8V、3.3V 和 5V 逻辑输入
- 内置 3.3V (5%)、30mA LDO 稳压器
- 内置 3.3V/5V、200mA 降压稳压器
- 延迟补偿减少占空比失真
- 整套集成保护特性
  - 电源欠压锁定 (UVLO)
  - 电荷泵欠压 (CPUV)
  - 过流保护 (OCP)
  - 电机锁定保护
  - 热警告和热关断 (OTW/OTSD)
  - 故障条件指示引脚 (nFAULT)
  - 可选择通过 SPI 接口进行故障诊断

## 2 应用

- 无刷直流 (BLDC) 电机模块
- 小型家用电器
- HVAC 电机
- 办公自动化设备
- 工厂自动化和机器人

## 3 说明

MCT8316Z 为要驱动 12V 至 24V 有刷直流电机的客户提供了一种单芯片无代码含传感器梯形解决方案。MCT8316Z 集成了三个 1/2 H 桥，具有 40V 的绝对最大电压和  $95\text{m}\Omega$  的超低  $R_{DS(ON)}$  (高侧和低侧相结合)，可提供大功率驱动能力。电流通过集成电流检测功能检测，无需再使用外部功率检测电阻器。可调降压稳压器和 LDO 的电源管理系列能够为器件生成必要的电压轨，可用于为外部电路供电。

MCT8316Z 在固定功能状态机中实现含传感器梯形控制，因此无需外部微控制器即可使无刷直流电机转动。该器件集成了三个用于位置感应的模拟霍尔比较器，以实现含传感器梯形 BLDC 电机控制。该控制方案具有高度可配置性，可通过硬件引脚或寄存器设置进行配置，范围涵盖从电机电流限制行为到故障响应。速度可以通过 PWM 输入进行控制。

MCT8316Z 集成多种保护特性，旨在出现故障事件时保护该器件、电机和系统。

有关器件使用的设计考虑因素和建议，请参考 [Application Information](#)。

### 器件信息<sup>(1)</sup>

器件型号	封装	封装尺寸 (标称值)
MCT8316ZR <sup>(2)</sup>	VQFN (40)	7.00mm x 5.00mm
MCT8316ZT	VQFN (40)	7.00mm x 5.00mm

- 如需了解所有可用封装，请参阅数据表末尾的可订购产品附录。
- 器件为预发布状态。

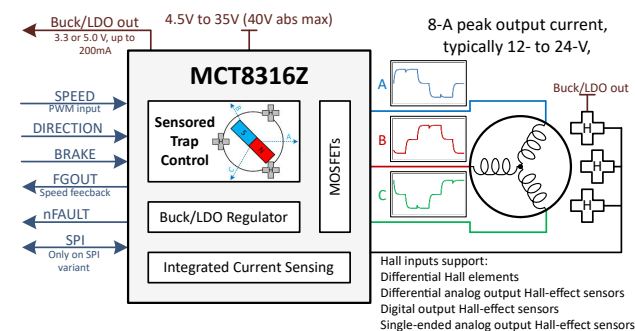

简化版原理图



## Table of Contents

<b>1 特性</b> .....	1	8.3 Feature Description.....	21
<b>2 应用</b> .....	1	8.4 Device Functional Modes.....	59
<b>3 说明</b> .....	1	8.5 SPI Communication.....	60
<b>4 Revision History</b> .....	2	8.6 Register Map.....	63
<b>5 Device Comparison Table</b> .....	3	<b>9 Application and Implementation</b> .....	78
<b>6 Pin Configuration and Functions</b> .....	4	9.1 Application Information.....	78
Pin Functions.....	5	9.2 Hall Sensor Configuration and Connection.....	79
<b>7 Specifications</b> .....	7	9.3 Typical Applications.....	83
7.1 Absolute Maximum Ratings .....	7	<b>10 Power Supply Recommendations</b> .....	88
7.2 ESD Ratings .....	7	10.1 Bulk Capacitance.....	88
7.3 Recommended Operating Conditions .....	7	<b>11 Layout</b> .....	89
7.4 Thermal Information .....	8	11.1 Layout Guidelines.....	89
7.5 Electrical Characteristics .....	8	11.2 Layout Example.....	90
7.6 SPI Timing Requirements .....	15	11.3 Thermal Considerations.....	91
7.7 SPI Secondary Mode Timings.....	16	<b>12 Device and Documentation Support</b> .....	92
7.8 Typical Characteristics.....	16	12.1 支持资源.....	92
<b>8 Detailed Description</b> .....	18	12.2 Trademarks.....	92
8.1 Overview.....	18	12.3 Electrostatic Discharge Caution.....	92
8.2 Functional Block Diagram.....	19	12.4 术语表.....	92

## 4 Revision History

Changes from , to , (from Revision * (March 2021) to Revision A (October 2021))	Page
• 将器件状态更新为“量产数据”。 .....	1

## 5 Device Comparison Table

DEVICE	PACKAGES	INTERFACE	BUCK REGULATOR
MCT8316ZR <sup>(1)</sup>	40-pin VQFN (7x5 mm)	SPI	Yes
MCT8316ZT		Hardware	

(1) Device available for preview only.

**表 5-1. MCT8316ZR (SPI variant) vs. MCT8316ZT (Hardware variant) configuration comparison**

Parameters	MCT8316ZR (SPI variant)	MCT8316ZT (Hardware variant)
PWM control mode settings	PWM_MODE (4 settings)	MODE pin (7 settings)
Slew rate settings	SLEW (4 settings)	SLEW pin (4 settings)
Direction settings	DIR (2 settings)	DIR pin (2 settings)
DRVOFF pin configuration	DRV_OFF (2 settings)	Enabled
Current limit threshold	ILIMIT pin: AVDD/2 to AVDD/2-0.4V	ILIMIT pin: AVDD/2 to AVDD/2-0.4V
Current limit configuration	ILIM_RECIR (2 settings), PWM_100_DUTY_SEL	Recirculation fixed to Brake mode and PWM frequency for 100% duty fixed to 20 kHz
CSA GAIN	CSA_GAIN (4 settings)	Fixed to 0.15 V/A
Lead angle settings	ADVANCE_LVL (8 settings)	ADVANCE pin (7 settings)
Buck enable	BUCK_DIS (2 settings)	Enabled
Buck threshold	BUCK_SEL (4 settings)	VSEL_BK pin (4 settings)
Buck configuration: power sequencing, current limit and slew rate	BUCK_PS_DIS (2 settings) and BUCK_CL (2 settings)	Power sequencing enabled, current limit: 600 mA and slew rate: 1000 V/us
FGOUT configuration	FGOUT_SEL (4 settings)	Fixed to commutation frequency
Motor lock configuration: mode, detection and retry timing	MTR_LOCK_MODE (4 settings), MTR_LOCK_TDET (4 settings), MTR_LOCK_RETRY (2 settings)	Enabled with latched shutdown mode and detection time of 1000 ms
Active demagnetization	EN_AAR (2 settings) and EN_ASR (2 settings)	MODE pin (7 settings)
OCP configuration: Mode,	OCP_MODE (4 settings), OCP_LVL (4 settings), OCP_DEG (4 settings) and OCP_RETRY (2 settings)	Enabled with latched shutdown mode, level is fixed to 16A with 0.6 us deglitch time
Overvoltage protection configuration	OVP_EN (2 settings), OVP_SEL (2 settings)	Enabled and level is fixed to 34V (typ)
Driver delay compensation configuration	DLYCMP_EN (2 settings), DLY_TARGET (16 settings)	Disabled
SDO pin configuration	SDO_MODE (2 settings)	NA
SPI fault configuration	SPI_PARITY (2 settings), SPI_SCLK_FLT (2 settings), SPI_ADDR_FLT (2 settings)	NA

## 6 Pin Configuration and Functions



图 6-1. MCT8316ZR 40-Pin VQFN With Exposed Thermal Pad Top View



图 6-2. MCT8316ZT 40-Pin VQFN With Exposed Thermal Pad Top View

## Pin Functions

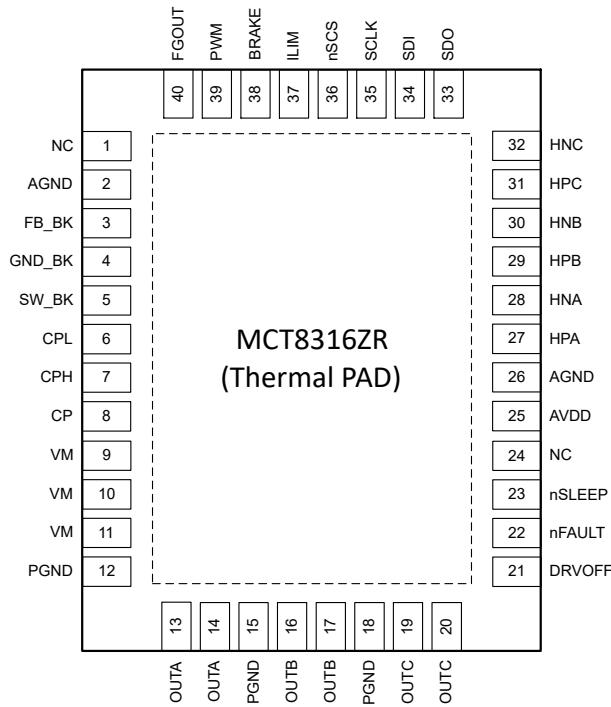
PIN NAME	40-pin Package		TYPE <sup>(1)</sup>	DESCRIPTION
	MCT8316ZR	MCT8316ZT		
ADVANCE	—	35	I	Advance angle level setting. This pin is a 7-level input pin set by an external resistor.
AGND	2, 26	2, 26	GND	Device analog ground. Refer <a href="#">Layout Guidelines</a> for connections recommendation.
AVDD	25	25	PWR O	3.3-V internal regulator output. Connect an X5R or X7R, 1- $\mu$ F, 6.3-V ceramic capacitor between the AVDD and AGND pins. This regulator can source up to 30 mA externally.
BRAKE	38	38	I	High $\rightarrow$ Brake the motor when High by turning all low side MOSFETs ON Low $\rightarrow$ normal operation
CP	8	8	PWR O	Charge pump output. Connect a X5R or X7R, 1- $\mu$ F, 16-V ceramic capacitor between the CP and VM pins.
CPH	7	7	PWR	Charge pump switching node. Connect a X5R or X7R, 47-nF, ceramic capacitor between the CPH and CPL pins. TI recommends a capacitor voltage rating at least twice the normal operating voltage of the device.
CPL	6	6	PWR	
DIR	—	36	I	Direction pin for setting the direction of the motor rotation to clockwise or counterclockwise.
DRVOFF	21	21	I	When this pin is pulled high the six MOSFETs in the power stage are turned OFF making all outputs Hi-Z.
FB_BK	3	3	PWR I	Feedback for buck regulator. Connect to buck regulator output after the inductor/resistor.
FGOUT	40	40	O	Motor Speed indicator output. Open-drain output requires an external pull-up resistor to 1.8V to 5.0V. It can be set to different division factor of Hall signals (see <a href="#">FGOUT Signal</a> )
GND_BK	4	4	GND	Buck regulator ground. Refer <a href="#">Layout Guidelines</a> for connections recommendation.
HPA	27	27	I	Phase A hall element positive input. Noise filter capacitors may be desirable, connected between the positive and negative hall inputs.
HPB	29	29	I	Phase B hall element positive input. Noise filter capacitors may be desirable, connected between the positive and negative hall inputs.
HPC	31	31	I	Phase C hall element positive input. Noise filter capacitors may be desirable, connected between the positive and negative hall inputs.
HNA	28	28	I	Phase A hall element negative input. Noise filter capacitors may be desirable, connected between the positive and negative hall inputs.
HNB	30	30	I	Phase B hall element negative input. Noise filter capacitors may be desirable, connected between the positive and negative hall inputs.
HNC	32	32	I	Phase C hall element negative input. Noise filter capacitors may be desirable, connected between the positive and negative hall inputs.
ILIM	37	37	I	Set the threshold for phase current used in cycle by cycle current limit.
MODE	—	33	I	PWM input mode setting. This pin is a 7-level input pin set by an external resistor.
NC	1, 24	1	—	No connection, open
nFAULT	22	22	O	Fault indicator. Pulled logic-low with fault condition; Open-drain output requires an external pull-up resistor to 1.8V to 5.0V. If external supply is used to pull up nFAULT, ensure that it is pulled to >2.2V on power up or the device will enter test mode
nSCS	36	—	I	Serial chip select. A logic low on this pin enables serial interface communication.
nSLEEP	23	23	I	Driver nSLEEP. When this pin is logic low, the device goes into a low-power sleep mode. An 20 to 40- $\mu$ s low pulse can be used to reset fault conditions without entering sleep mode.
OUTA	13, 14	13, 14	PWR O	Half bridge output A
OUTB	16, 17	16, 17	PWR O	Half bridge output B

PIN NAME	40-pin Package		TYPE <sup>(1)</sup>	DESCRIPTION
	MCT8316ZR	MCT8316ZT		
OUTC	19, 20	19, 20	PWR O	Half bridge output C
PGND	12, 15, 18	12, 15, 18	GND	Device power ground. Refer <a href="#">Layout Guidelines</a> for connections recommendation.
PWM	39	39	I	PWM input for motor control. Set the duty cycle and switching frequency of the phase voltage of the motor.
SCLK	35	—	I	Serial clock input. Serial data is shifted out and captured on the corresponding rising and falling edge on this pin (SPI devices).
SDI	34	—	I	Serial data input. Data is captured on the falling edge of the SCLK pin (SPI devices).
SDO	33	—	O	Serial data output. Data is shifted out on the rising edge of the SCLK pin. This pin requires an external pullup resistor (SPI devices).
SLEW	—	34	I	Slew rate control setting. This pin is a 4-level input pin set by an external resistor (Hardware devices).
SW_BK	5	5	PWR O	Buck switch node. Connect this pin to an inductor or resistor.
VM	9, 10, 11	9, 10, 11	PWR I	Power supply. Connect to motor supply voltage; bypass to PGND with two 0.1- $\mu$ F capacitors (for each pin) plus one bulk capacitor rated for VM. TI recommends a capacitor voltage rating at least twice the normal operating voltage of the device.
VSEL_BK	—	24	I	Buck output voltage setting. This pin is a 4-level input pin set by an external resistor.
Thermal pad			GND	Must be connected to analog ground.

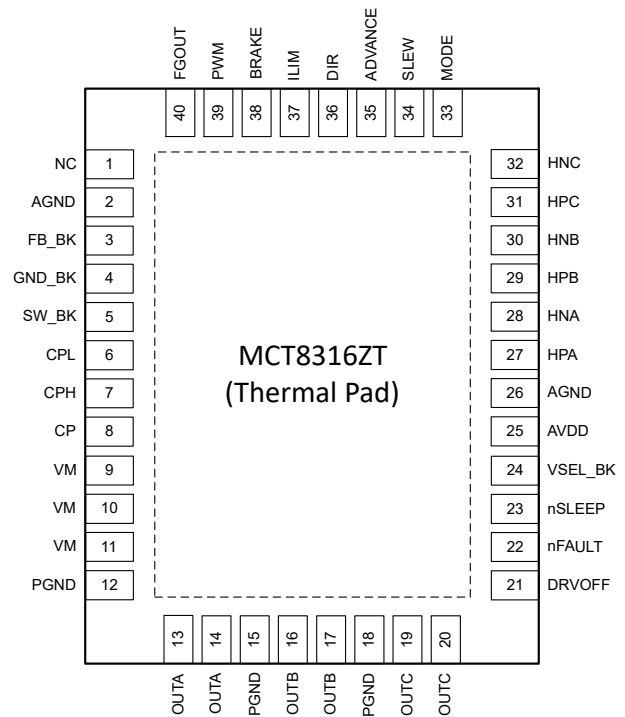
(1) I = input, O = output, GND = ground pin, PWR = power, NC = no connect

## 7 Specifications

### 7.1 Absolute Maximum Ratings

over operating ambient temperature range (unless otherwise noted)<sup>(1)</sup>

	MIN	MAX	UNIT
Power supply pin voltage (VM)	- 0.3	40	V
Power supply voltage ramp (VM)		4	V/μs
Voltage difference between ground pins (GND_BK, PGND, AGND)	- 0.3	0.3	V
Charge pump voltage (CPH, CP)	- 0.3	V <sub>M</sub> + 6	V
Charge pump negative switching pin voltage (CPL)	- 0.3	V <sub>M</sub> + 0.3	V
Switching regulator pin voltage (FB_BK)	- 0.3	5.75	V
Switching node pin voltage (SW_BK)	- 0.3	V <sub>M</sub> + 0.3	V
Analog regulators pin voltage (AVDD)	- 0.3	4	V
Logic pin input voltage (DRVOFF, PWM, nSCS, nSLEEP, SCLK, SDI)	- 0.3	5.75	V
Logic pin output voltage (nFAULT, SDO)	- 0.3	5.75	V
Output pin voltage (OUTA, OUTB, OUTC)	- 1	V <sub>M</sub> + 1	V
Ambient temperature, T <sub>A</sub>	- 40	125	°C
Junction temperature, T <sub>J</sub>	- 40	150	°C
Storage temperature, T <sub>stg</sub>	- 65	150	°C

- (1) Operation outside the Absolute Maximum Ratings may cause permanent device damage. Absolute Maximum Ratings do not imply functional operation of the device at these or any other conditions beyond those listed under Recommended Operating Conditions. If used outside the Recommended Operating Conditions but within the Absolute Maximum Ratings, the device may not be fully functional, and this may affect device reliability, functionality, performance, and shorten the device lifetime.

### 7.2 ESD Ratings

			VALUE	UNIT
V <sub>(ESD)</sub>	Electrostatic discharge	Human body model (HBM), per ANSI/ESDA/JEDEC JS-001 <sup>(1)</sup>	±2000	V
		Charged device model (CDM), per ANSI/ESDA/JEDEC JS-002 <sup>(2)</sup>	±500	

- (1) JEDEC document JEP155 states that 500-V HBM allows safe manufacturing with a standard ESD control process.  
(2) JEDEC document JEP157 states that 250-V CDM allows safe manufacturing with a standard ESD control process.

### 7.3 Recommended Operating Conditions

over operating ambient temperature range (unless otherwise noted)

			MIN	NOM	MAX	UNIT
V <sub>VM</sub>	Power supply voltage	V <sub>VM</sub>	4.5	24	35	V
f <sub>PWM</sub>	Output PWM frequency	OUTA, OUTB, OUTC			200	kHz
I <sub>OUT</sub> <sup>(1)</sup>	Peak output winding current	OUTA, OUTB, OUTC			8	A
V <sub>IN</sub>	Logic input voltage	DRVOFF, INHx, INLx, nSCS, nSLEEP, SCLK, SDI	- 0.1		5.5	V
V <sub>OD</sub>	Open drain pullup voltage	nFAULT, SDO	- 0.1		5.5	V
V <sub>SDO</sub>	Push-pull voltage	SDO	2.2		5.5	V
I <sub>OD</sub>	Open drain output current	nFAULT, SDO			5	mA
V <sub>VREF</sub>	Voltage reference pin voltage	VREF	2.8		AVDD	V
T <sub>A</sub>	Operating ambient temperature		- 40		125	°C
T <sub>J</sub>	Operating Junction temperature		- 40		150	°C

- (1) Power dissipation and thermal limits must be observed

## 7.4 Thermal Information

THERMAL METRIC <sup>(1)</sup>		MCT8316ZT, MCT8316ZR	UNIT
		VQFN (RGF)	
		40 Pins	
$R_{\theta JA}$	Junction-to-ambient thermal resistance	25.7	°C/W
$R_{\theta JC(top)}$	Junction-to-case (top) thermal resistance	15.2	°C/W
$R_{\theta JB}$	Junction-to-board thermal resistance	7.3	°C/W
$\Psi_{JT}$	Junction-to-top characterization parameter	0.2	°C/W
$\Psi_{JB}$	Junction-to-board characterization parameter	7.2	°C/W
$R_{\theta JC(bot)}$	Junction-to-case (bottom) thermal resistance	2.0	°C/W

(1) For more information about traditional and new thermal metrics, see the [Semiconductor and IC Package Thermal Metrics](#) application report.

## 7.5 Electrical Characteristics

$T_J = -40^{\circ}\text{C}$  to  $+150^{\circ}\text{C}$ ,  $V_{VM} = 4.5$  to  $35\text{ V}$  (unless otherwise noted). Typical limits apply for  $T_A = 25^{\circ}\text{C}$ ,  $V_{VM} = 24\text{ V}$

PARAMETER		TEST CONDITIONS	MIN	TYP	MAX	UNIT
<b>POWER SUPPLIES</b>						
$I_{VMQ}$	VM sleep mode current	$V_{VM} > 6\text{ V}$ , nSLEEP = 0, $T_A = 25^{\circ}\text{C}$		1.5	2.5	$\mu\text{A}$
		nSLEEP = 0		2.5	5	$\mu\text{A}$
$I_{VMS}$	VM standby mode current (Buck regulator disabled)	nSLEEP = 1, PWM = 0, SPI = 'OFF', BUCK_DIS = 1;		4	10	mA
		$V_{VM} > 6\text{ V}$ , nSLEEP = 1, PWM = 0, SPI = 'OFF', $T_A = 25^{\circ}\text{C}$ , BUCK_DIS = 1;		4	5	mA
$I_{VMS}$	VM standby mode current (Buck regulator enabled)	$V_{VM} > 6\text{ V}$ , nSLEEP = 1, PWM = 0, SPI = 'OFF', $I_{BK} = 0$ , $T_A = 25^{\circ}\text{C}$ , BUCK_DIS = 0;		5	6	mA
		nSLEEP = 1, PWM = 0, SPI = 'OFF', $I_{BK} = 0$ , BUCK_DIS = 0;		6	10	mA
$I_{VM}$	VM operating mode current (Buck regulator disabled)	$V_{VM} > 6\text{ V}$ , nSLEEP = 1, $f_{PWM} = 25\text{ kHz}$ , $T_A = 25^{\circ}\text{C}$ , BUCK_DIS = 1		10	13	mA
		$V_{VM} > 6\text{ V}$ , nSLEEP = 1, $f_{PWM} = 200\text{ kHz}$ , $T_A = 25^{\circ}\text{C}$ , BUCK_DIS = 1		18	21	mA
		nSLEEP = 1, $f_{PWM} = 25\text{ kHz}$ , BUCK_DIS = 1		11	15	mA
		nSLEEP = 1, $f_{PWM} = 200\text{ kHz}$ , BUCK_DIS = 1		17	24	mA
$I_{VM}$	VM operating mode current (Buck regulator enabled)	$V_{VM} > 6\text{ V}$ , nSLEEP = 1, $f_{PWM} = 25\text{ kHz}$ , $T_A = 25^{\circ}\text{C}$ , BUCK_DIS = 0; BUCK_PS_DIS = 0		11	13	mA
		$V_{VM} > 6\text{ V}$ , nSLEEP = 1, $f_{PWM} = 200\text{ kHz}$ , $T_A = 25^{\circ}\text{C}$ , BUCK_DIS = 0; BUCK_PS_DIS = 0		19	22	mA
		nSLEEP = 1, $f_{PWM} = 25\text{ kHz}$ , BUCK_DIS = 0; BUCK_PS_DIS = 0		12	16	mA
		nSLEEP = 1, $f_{PWM} = 200\text{ kHz}$ , BUCK_DIS = 0; BUCK_PS_DIS = 0		18	27	mA
$V_{AVDD}$	Analog regulator voltage	$0\text{ mA} \leq I_{AVDD} \leq 30\text{ mA}$ ; BUCK_PS_DIS = 0	3.1	3.3	3.465	V
$I_{AVDD}$	External analog regulator load				30	mA
$V_{VCP}$	Charge pump regulator voltage	VCP with respect to VM	3.6	4.7	5.2	V
$f_{CP}$	Charge pump switching frequency			400		kHz

$T_J = -40^{\circ}\text{C}$  to  $+150^{\circ}\text{C}$ ,  $V_{VM} = 4.5$  to  $35\text{ V}$  (unless otherwise noted). Typical limits apply for  $T_A = 25^{\circ}\text{C}$ ,  $V_{VM} = 24\text{ V}$

PARAMETER		TEST CONDITIONS	MIN	TYP	MAX	UNIT
$t_{\text{PWM\_LOW}}$	PWM low time required for motor lock detection			200		ms
$t_{\text{WAKE}}$	Wakeup time	$V_{VM} > V_{\text{UVLO}}$ , nSLEEP = 1 to outputs ready and nFAULT released			1	ms
$t_{\text{SLEEP}}$	Sleep Pulse time	nSLEEP = 0 period to enter sleep mode	120			$\mu\text{s}$
$t_{\text{RST}}$	Reset Pulse time	nSLEEP = 0 period to reset faults	20		40	$\mu\text{s}$
<b>BUCK REGULATOR</b>						
$V_{\text{BK}}$	Buck regulator average voltage ( $L_{\text{BK}} = 47\ \mu\text{H}$ , $C_{\text{BK}} = 22\ \mu\text{F}$ ) (SPI Device)	$V_{VM} > 6\text{ V}$ , $0\text{ mA} \leq I_{\text{BK}} \leq 200\text{ mA}$ , BUCK_SEL = 00b	3.1	3.3	3.5	V
		$V_{VM} > 6\text{ V}$ , $0\text{ mA} \leq I_{\text{BK}} \leq 200\text{ mA}$ , BUCK_SEL = 01b	4.6	5.0	5.4	V
		$V_{VM} > 6\text{ V}$ , $0\text{ mA} \leq I_{\text{BK}} \leq 200\text{ mA}$ , BUCK_SEL = 10b	3.7	4.0	4.3	V
		$V_{VM} > 6.7\text{ V}$ , $0\text{ mA} \leq I_{\text{BK}} \leq 200\text{ mA}$ , BUCK_SEL = 11b	5.2	5.7	6.2	V
		$V_{VM} < 6.0\text{ V}$ (BUCK_SEL = 00b, 01b, 10b) or $V_{VM} < 6.0\text{ V}$ (BUCK_SEL = 11b), $0\text{ mA} \leq I_{\text{BK}} \leq 200\text{ mA}$		$V_{VM} - I_{\text{BK}} * (R_{\text{LBK}} + 2)$ <sup>(1)</sup>		V
$V_{\text{BK}}$	Buck regulator average voltage ( $L_{\text{BK}} = 22\ \mu\text{H}$ , $C_{\text{BK}} = 22\ \mu\text{F}$ ) (SPI Device)	$V_{VM} > 6\text{ V}$ , $0\text{ mA} \leq I_{\text{BK}} \leq 50\text{ mA}$ , BUCK_SEL = 00b	3.1	3.3	3.5	V
		$V_{VM} > 6\text{ V}$ , $0\text{ mA} \leq I_{\text{BK}} \leq 50\text{ mA}$ , BUCK_SEL = 01b	4.6	5.0	5.4	V
		$V_{VM} > 6\text{ V}$ , $0\text{ mA} \leq I_{\text{BK}} \leq 50\text{ mA}$ , BUCK_SEL = 10b	3.7	4.0	4.3	V
		$V_{VM} > 6.7\text{ V}$ , $0\text{ mA} \leq I_{\text{BK}} \leq 50\text{ mA}$ , BUCK_SEL = 11b	5.2	5.7	6.2	V
		$V_{VM} < 6.0\text{ V}$ (BUCK_SEL = 00b, 01b, 10b) or $V_{VM} < 6.0\text{ V}$ (BUCK_SEL = 11b), $0\text{ mA} \leq I_{\text{BK}} \leq 50\text{ mA}$		$V_{VM} - I_{\text{BK}} * (R_{\text{LBK}} + 2)$ <sup>(1)</sup>		V
$V_{\text{BK}}$	Buck regulator average voltage ( $R_{\text{BK}} = 22\ \Omega$ , $C_{\text{BK}} = 22\ \mu\text{F}$ ) (SPI Device)	$V_{VM} > 6\text{ V}$ , $0\text{ mA} \leq I_{\text{BK}} \leq 40\text{ mA}$ , BUCK_SEL = 00b	3.1	3.3	3.5	V
		$V_{VM} > 6\text{ V}$ , $0\text{ mA} \leq I_{\text{BK}} \leq 40\text{ mA}$ , BUCK_SEL = 01b	4.6	5.0	5.4	V
		$V_{VM} > 6\text{ V}$ , $0\text{ mA} \leq I_{\text{BK}} \leq 40\text{ mA}$ , BUCK_SEL = 10b	3.7	4.0	4.3	V
		$V_{VM} > 6.7\text{ V}$ , $0\text{ mA} \leq I_{\text{BK}} \leq 40\text{ mA}$ , BUCK_SEL = 11b	5.2	5.7	6.2	V
		$V_{VM} < 6.0\text{ V}$ (BUCK_SEL = 00b, 01b, 10b) or $V_{VM} < 6.0\text{ V}$ (BUCK_SEL = 11b), $0\text{ mA} \leq I_{\text{BK}} \leq 40\text{ mA}$		$V_{VM} - I_{\text{BK}} * (R_{\text{BK}} + 2)$ <sup>(1)</sup>		V
$V_{\text{BK}}$	Buck regulator average voltage ( $L_{\text{BK}} = 47\ \mu\text{H}$ , $C_{\text{BK}} = 22\ \mu\text{F}$ ) (HW Device)	$V_{VM} > 6\text{ V}$ , $0\text{ mA} \leq I_{\text{BK}} \leq 200\text{ mA}$ , VSEL_BK pin tied to AGND	3.1	3.3	3.5	V
		$V_{VM} > 6\text{ V}$ , $0\text{ mA} \leq I_{\text{BK}} \leq 200\text{ mA}$ , VSEL_BK pin to Hi-Z	4.6	5.0	5.4	
		$V_{VM} > 6\text{ V}$ , $0\text{ mA} \leq I_{\text{BK}} \leq 200\text{ mA}$ , VSEL_BK pin to $47\text{ k}\Omega$ +/- 5% tied to AVDD	3.7	4.0	4.3	
		$V_{VM} > 6.7\text{ V}$ , $0\text{ mA} \leq I_{\text{BK}} \leq 200\text{ mA}$ , VSEL_BK pin to AGND	5.2	5.7	6.2	
		$V_{VM} < 6.0\text{ V}$ , $0\text{ mA} \leq I_{\text{BK}} \leq 200\text{ mA}$		$V_{VM} - I_{\text{BK}} * (R_{\text{LBK}} + 2)$ <sup>(1)</sup>		V

$T_J = -40^\circ\text{C}$  to  $+150^\circ\text{C}$ ,  $V_{VM} = 4.5$  to  $35$  V (unless otherwise noted). Typical limits apply for  $T_A = 25^\circ\text{C}$ ,  $V_{VM} = 24$  V

PARAMETER		TEST CONDITIONS	MIN	TYP	MAX	UNIT
$V_{BK}$	Buck regulator average voltage ( $L_{BK} = 22 \mu\text{H}$ , $C_{BK} = 22 \mu\text{F}$ ) (HW Device)	$V_{VM} > 6$ V, $0 \text{ mA} \leq I_{BK} \leq 50$ mA, VSEL_BK pin tied to AGND	3.1	3.3	3.5	V
		$V_{VM} > 6$ V, $0 \text{ mA} \leq I_{BK} \leq 50$ mA, VSEL_BK pin to Hi-Z	4.6	5.0	5.4	V
		$V_{VM} > 6$ V, $0 \text{ mA} \leq I_{BK} \leq 50$ mA, VSEL_BK pin to $47 \text{ k}\Omega$ +/- 5% tied to AVDD	3.7	4.0	4.3	V
		$V_{VM} > 6.7$ V, $0 \text{ mA} \leq I_{BK} \leq 50$ mA, VSEL_BK pin to AGND	5.2	5.7	6.2	V
		$V_{VM} < 6.0$ V, $0 \text{ mA} \leq I_{BK} \leq 50$ mA		$V_{VM} -$ $I_{BK} * (R_{LBK} +$ $2)^{(1)}$		V
$V_{BK}$	Buck regulator average voltage ( $R_{BK} = 22 \Omega$ , $C_{BK} = 22 \mu\text{F}$ ) (HW Device)	$V_{VM} > 6$ V, $0 \text{ mA} \leq I_{BK} \leq 40$ mA, VSEL_BK pin tied to AGND	3.1	3.3	3.5	V
		$V_{VM} > 6$ V, $0 \text{ mA} \leq I_{BK} \leq 40$ mA, VSEL_BK pin to Hi-Z	4.6	5.0	5.4	V
		$V_{VM} > 6$ V, $0 \text{ mA} \leq I_{BK} \leq 40$ mA, VSEL_BK pin to $47 \text{ k}\Omega$ +/- 5% tied to AVDD	3.7	4.0	4.3	V
		$V_{VM} > 6.7$ V, $0 \text{ mA} \leq I_{BK} \leq 40$ mA, VSEL_BK pin to AGND	5.2	5.7	6.2	V
		$V_{VM} < 6.0$ V, $0 \text{ mA} \leq I_{BK} \leq 40$ mA		$V_{VM} -$ $I_{BK} * (R_{BK} + 2$ $)^{(1)}$		V
$V_{BK\_RIP}$	Buck regulator ripple voltage	$V_{VM} > 6$ V, $0 \text{ mA} \leq I_{BK} \leq 200$ mA, Buck regulator with inductor, $L_{BK} = 47 \text{ uH}$ , $C_{BK}$ $= 22 \mu\text{F}$	- 100		100	mV
		$V_{VM} > 6$ V, $0 \text{ mA} \leq I_{BK} \leq 50$ mA, Buck regulator with inductor, $L_{BK} = 22 \text{ uH}$ , $C_{BK}$ $= 22 \mu\text{F}$	- 100		100	mV
		$V_{VM} > 6$ V, $0 \text{ mA} \leq I_{BK} \leq 50$ mA, Buck regulator with resistor; $R_{BK} = 22 \Omega$ , $C_{BK}$ $= 22 \mu\text{F}$	- 100		100	mV
$I_{BK}$	External buck regulator load	$L_{BK} = 47 \text{ uH}$ , $C_{BK} = 22 \mu\text{F}$ , BUCK_PS_DIS = 1b			200	mA
		$L_{BK} = 47 \text{ uH}$ , $C_{BK} = 22 \mu\text{F}$ , BUCK_PS_DIS = 0b			200 - $I_{AVDD}$	mA
		$L_{BK} = 22 \text{ uH}$ , $C_{BK} =$ $22 \mu\text{F}$ , BUCK_PS_DIS = 1b			50	mA
		$L_{BK} = 22 \text{ uH}$ , $C_{BK} = 22 \mu\text{F}$ , BUCK_PS_DIS = 0b			50 - $I_{AVDD}$	mA
		$R_{BK} = 22 \Omega$ , $C_{BK} =$ $22 \mu\text{F}$ , BUCK_PS_DIS = 1b			40	mA
		$R_{BK} = 22 \Omega$ , $C_{BK} = 22 \mu\text{F}$ , BUCK_PS_DIS = 0b			40 - $I_{AVDD}$	mA
$f_{SW\_BK}$	Buck regulator switching frequency	Regulation Mode	20		535	kHz
		Linear Mode	20		535	kHz

$T_J = -40^{\circ}\text{C to } +150^{\circ}\text{C}$ ,  $V_{VM} = 4.5 \text{ to } 35 \text{ V}$  (unless otherwise noted). Typical limits apply for  $T_A = 25^{\circ}\text{C}$ ,  $V_{VM} = 24 \text{ V}$ 

PARAMETER		TEST CONDITIONS	MIN	TYP	MAX	UNIT
V <sub>BK_UV</sub>	Buck regulator undervoltage lockout (SPI Device)	V <sub>BK</sub> rising, BUCK_SEL = 00b	2.7	2.8	2.9	V
		V <sub>BK</sub> falling, BUCK_SEL = 00b	2.5	2.6	2.7	V
		V <sub>BK</sub> rising, BUCK_SEL = 01b	4.2	4.4	4.55	V
		V <sub>BK</sub> falling, BUCK_SEL = 01b	4.0	4.2	4.35	V
		V <sub>BK</sub> rising, BUCK_SEL = 10b	2.7	2.8	2.9	V
		V <sub>BK</sub> falling, BUCK_SEL = 10b	2.5	2.6	2.7	V
		V <sub>BK</sub> rising, BUCK_SEL = 11b	4.2	4.4	4.55	V
		V <sub>BK</sub> falling, BUCK_SEL = 11b	4	4.2	4.35	V
V <sub>BK_UV</sub>	Buck regulator undervoltage lockout (HW Device)	V <sub>BK</sub> rising, VSEL_BK pin tied to AGND	2.7	2.8	2.9	V
		V <sub>BK</sub> falling, VSEL_BK pin tied to AGND	2.5	2.6	2.7	V
		V <sub>BK</sub> rising, VSEL_BK pin to 47 k $\Omega$ +/- 5% tied to AVDD	4.3	4.4	4.5	V
		V <sub>BK</sub> falling, VSEL_BK pin to 47 k $\Omega$ +/- 5% tied to AVDD	4.1	4.2	4.3	V
		V <sub>BK</sub> rising, VSEL_BK pin to Hi-Z	2.7	2.8	2.9	V
		V <sub>BK</sub> falling, VSEL_BK pin to Hi-Z	2.5	2.6	2.7	V
		V <sub>BK</sub> rising, VSEL_BK pin tied to AVDD	4.2	4.4	4.55	V
		V <sub>BK</sub> falling, VSEL_BK pin tied to AVDD	4.0	4.2	4.35	V
V <sub>BK_UV_HYS</sub>	Buck regulator undervoltage lockout hysteresis	Rising to falling threshold	90	200	320	mV
I <sub>BK_CL</sub>	Buck regulator Current limit threshold (SPI Device)	BUCK_CL = 0b	360	600	900	mA
		BUCK_CL = 1b	80	150	250	mA
I <sub>BK_CL</sub>	Buck regulator Current limit threshold (HW Device)		360	600	900	mA
I <sub>BK_OCP</sub>	Buck regulator Overcurrent protection trip point		2	3	4	A
t <sub>BK_RETRY</sub>	Overcurrent protection retry time		0.7	1	1.3	ms
<b>LOGIC-LEVEL INPUTS (BRAKE, DIR, DRVOFF, nSLEEP, PWM, SCLK, SDI)</b>						
V <sub>IL</sub>	Input logic low voltage		0		0.6	V
V <sub>IH</sub>	Input logic high voltage	Other Pins	1.5		5.5	V
		nSLEEP	1.6		5.5	V
V <sub>HYS</sub>	Input logic hysteresis	Other Pins	180	300	420	mV
		nSLEEP	95	250	420	mV
I <sub>IL</sub>	Input logic low current	V <sub>PIN</sub> (Pin Voltage) = 0 V	- 1		1	$\mu$ A
I <sub>IH</sub>	Input logic high current	nSLEEP, V <sub>PIN</sub> (Pin Voltage) = 5 V	10		30	$\mu$ A
		Other pins, V <sub>PIN</sub> (Pin Voltage) = 5 V	30		75	$\mu$ A
R <sub>PD</sub>	Input pulldown resistance	nSLEEP	150	200	300	k $\Omega$
		Other pins	70	100	130	k $\Omega$
C <sub>ID</sub>	Input capacitance			30		pF
<b>LOGIC-LEVEL INPUTS (nSCS)</b>						
V <sub>IL</sub>	Input logic low voltage		0		0.6	V
V <sub>IH</sub>	Input logic high voltage		1.5		5.5	V
V <sub>HYS</sub>	Input logic hysteresis		180	300	420	mV
I <sub>IL</sub>	Input logic low current	V <sub>PIN</sub> (Pin Voltage) = 0 V			75	$\mu$ A
I <sub>IH</sub>	Input logic high current	V <sub>PIN</sub> (Pin Voltage) = 5 V	- 1		25	$\mu$ A
R <sub>PU</sub>	Input pullup resistance		80	100	130	k $\Omega$
C <sub>ID</sub>	Input capacitance			30		pF

**MCT8316Z**

ZHCSNP1A - MARCH 2021 - REVISED OCTOBER 2021

 $T_J = -40^{\circ}\text{C}$  to  $+150^{\circ}\text{C}$ ,  $V_{VM} = 4.5$  to  $35$  V (unless otherwise noted). Typical limits apply for  $T_A = 25^{\circ}\text{C}$ ,  $V_{VM} = 24$  V

PARAMETER		TEST CONDITIONS	MIN	TYP	MAX	UNIT
<b>FOUR-LEVEL INPUTS (SLEW, VSEL_BK)</b>						
$V_{L1}$	Input mode 1 voltage	Tied to AGND	0		$0.2 \cdot AV_{DD}$	V
$V_{L2}$	Input mode 2 voltage	Hi-Z	$0.27 \cdot AV_{DD}$	$0.5 \cdot AV_{DD}$	$0.545 \cdot AV_{DD}$	V
$V_{L3}$	Input mode 3 voltage	47 k $\Omega$ +/- 5% tied to AVDD	$0.606 \cdot AV_{DD}$	$0.757 \cdot AV_{DD}$	$0.909 \cdot AV_{DD}$	V
$V_{L4}$	Input mode 4 voltage	Tied to AVDD	$0.945 \cdot AV_{DD}$		AVDD	V
$R_{PU}$	Input pullup resistance	To AVDD	70	100	130	k $\Omega$
$R_{PD}$	Input pulldown resistance	To AGND	70	100	130	k $\Omega$
<b>FOUR-LEVEL INPUTS (OCP/SR)</b>						
$V_{L1}$	Input mode 1 voltage	Tied to AGND	0		$0.09 \cdot AV_{DD}$	V
$V_{L2}$	Input mode 2 voltage	22 k $\Omega$ $\pm$ 5% to AGND	$0.12 \cdot AV_{DD}$	$0.15 \cdot AV_{DD}$	$0.2 \cdot AV_{DD}$	V
$V_{L3}$	Input mode 3 voltage	100 k $\Omega$ $\pm$ 5% to AGND	$0.27 \cdot AV_{DD}$	$0.33 \cdot AV_{DD}$	$0.4 \cdot AV_{DD}$	V
$V_{L4}$	Input mode 4 voltage	Hi-Z	$0.45 \cdot AV_{DD}$	$0.5 \cdot AV_{DD}$	$0.55 \cdot AV_{DD}$	V
$V_{L5}$	Input mode 5 voltage	100 k $\Omega$ $\pm$ 5% to AVDD	$0.6 \cdot AV_{DD}$	$0.66 \cdot AV_{DD}$	$0.73 \cdot AV_{DD}$	V
$V_{L6}$	Input mode 6 voltage	22 k $\Omega$ $\pm$ 5% to AVDD	$0.77 \cdot AV_{DD}$	$0.85 \cdot AV_{DD}$	$0.9 \cdot AV_{DD}$	V
$V_{L7}$	Input mode 7 voltage	Tied to AVDD	$0.94 \cdot AV_{DD}$		AVDD	V
$R_{PU}$	Input pullup resistance	To AVDD	80	100	120	k $\Omega$
$R_{PD}$	Input pulldown resistance	To AGND	80	100	120	k $\Omega$
<b>OPEN-DRAIN OUTPUTS (FGOUT, nFAULT)</b>						
$V_{OL}$	Output logic low voltage	$I_{OD} = 5$ mA			0.4	V
$I_{OH}$	Output logic high current	$V_{OD} = 5$ V	-1		1	$\mu$ A
$C_{OD}$	Output capacitance				30	pF
<b>PUSH-PULL OUTPUTS (SDO)</b>						
$V_{OL}$	Output logic low voltage	$I_{OP} = 5$ mA	0		0.4	V
$V_{OH}$	Output logic high voltage	$I_{OP} = 5$ mA	2.2		5.5	V
$I_{OL}$	Output logic low leakage current	$V_{OP} = 0$ V	-1		1	$\mu$ A
$I_{OH}$	Output logic high leakage current	$V_{OP} = 5$ V	-1		1	$\mu$ A
$C_{OD}$	Output capacitance				30	pF
<b>DRIVER OUTPUTS</b>						
$R_{DS(ON)}$	Total MOSFET on resistance (High-side + Low-side)	$V_{VM} > 6$ V, $I_{OUT} = 1$ A, $T_A = 25^{\circ}\text{C}$		95	120	m $\Omega$
		$V_{VM} < 6$ V, $I_{OUT} = 1$ A, $T_A = 25^{\circ}\text{C}$		105	130	m $\Omega$
		$V_{VM} > 6$ V, $I_{OUT} = 1$ A, $T_J = 150^{\circ}\text{C}$		140	185	m $\Omega$
		$V_{VM} < 6$ V, $I_{OUT} = 1$ A, $T_J = 150^{\circ}\text{C}$		145	190	m $\Omega$

$T_J = -40^{\circ}\text{C}$  to  $+150^{\circ}\text{C}$ ,  $V_{VM} = 4.5$  to  $35\text{ V}$  (unless otherwise noted). Typical limits apply for  $T_A = 25^{\circ}\text{C}$ ,  $V_{VM} = 24\text{ V}$

PARAMETER		TEST CONDITIONS	MIN	TYP	MAX	UNIT
SR	Phase pin slew rate switching low to high (Rising from 20 % to 80 %)	$V_{VM} = 24\text{ V}$ , SLEW = 00b or SLEW pin tied to AGND	14	25	45	V/us
		$V_{VM} = 24\text{ V}$ , SLEW = 01b or SLEW pin to Hi-Z	30	50	80	V/us
		$V_{VM} = 24\text{ V}$ , SLEW = 10b or SLEW pin to $47\text{ k}\Omega$ +/- 5% to AVDD	80	125	185	V/us
		$V_{VM} = 24\text{ V}$ , SLEW = 11b or SLEW pin tied to AVDD	130	200	280	V/us
SR	Phase pin slew rate switching high to low (Falling from 80 % to 20 %)	$V_{VM} = 24\text{ V}$ , SLEW = 00b or SLEW pin tied to AGND	14	25	45	V/us
		$V_{VM} = 24\text{ V}$ , SLEW = 01b or SLEW pin to Hi-Z	30	50	80	V/us
		$V_{VM} = 24\text{ V}$ , SLEW = 10b or SLEW pin to $47\text{ k}\Omega$ +/- 5% to AVDD	80	125	185	V/us
		$V_{VM} = 24\text{ V}$ , SLEW = 11b or SLEW pin tied to AVDD	110	200	280	V/us
$I_{LEAK}$	Leakage current on OUTx	$V_{OUTx} = V_{VM}$ , nSLEEP = 1			5	mA
	Leakage current on OUTx	$V_{OUTx} = 0\text{ V}$ , nSLEEP = 1			1	$\mu\text{A}$
$t_{DEAD}$	Output dead time (high to low / low to high)	$V_{VM} = 24\text{ V}$ , SR = 25 V/ $\mu\text{s}$ , HS driver ON to LS driver OFF		1800	3400	ns
		$V_{VM} = 24\text{ V}$ , SR = 50 V/ $\mu\text{s}$ , HS driver ON to LS driver OFF		1100	1550	ns
		$V_{VM} = 24\text{ V}$ , SR = 125 V/ $\mu\text{s}$ , HS driver ON to LS driver OFF		650	1000	ns
		$V_{VM} = 24\text{ V}$ , SR = 200 V/ $\mu\text{s}$ , HS driver ON to LS driver OFF		500	750	ns
$t_{PD}$	Propagation delay (high-side / low-side ON/OFF)	$V_{VM} = 24\text{ V}$ , PWM = 1 to OUTx transition, SR = 25 V/ $\mu\text{s}$		2000	4550	ns
		$V_{VM} = 24\text{ V}$ , PWM = 1 to OUTx transition, SR = 50V/ $\mu\text{s}$		1200	2150	ns
		$V_{VM} = 24\text{ V}$ , PWM = 1 to OUTx transition, SR = 125 V/ $\mu\text{s}$		800	1350	ns
		$V_{VM} = 24\text{ V}$ , PWM = 1 to OUTx transition, SR = 200 V/ $\mu\text{s}$		650	1050	ns
$t_{MIN\_PULSE}$	Minimum output pulse width	SR = 200 V/ $\mu\text{s}$	600			ns
<b>HALL COMPARATORS</b>						
$V_{ICM}$	Input Common Mode Voltage (Hall)		0.5	AVDD - 1.2		V
$V_{HYS}$	Voltage hysteresis (SPI Device)	HALL_HYS = 0	1.5	5	8	mV
		HALL_HYS = 1	35	50	75	mV
	Voltage hysteresis (HW Device)		1.5	5	8	mV
$\Delta V_{HYS}$	Hall comparator hysteresis difference	Between Hall A, Hall B and Hall C comparator	- 8		8	mV
$V_{H(MIN)}$	Minimum Hall Differential Voltage		40			mV
$I_I$	Input leakage current	HPX = HNX = 0 V	- 1		1	$\mu\text{A}$
$t_{HDG}$	Hall deglitch time		0.7	1.15	1.7	$\mu\text{s}$
$t_{HEDG}$	Hall Enable deglitch time	During Power up		1.4		$\mu\text{s}$
<b>PULSE-BY-PULSE CURRENT LIMIT</b>						
$V_{LIM}$	Voltage on VLIM pin for cycle by cycle current limit		AVDD/2	AVDD/2 - 0.4		V

$T_J = -40^{\circ}\text{C}$  to  $+150^{\circ}\text{C}$ ,  $V_{VM} = 4.5$  to  $35$  V (unless otherwise noted). Typical limits apply for  $T_A = 25^{\circ}\text{C}$ ,  $V_{VM} = 24$  V

PARAMETER		TEST CONDITIONS	MIN	TYP	MAX	UNIT
$I_{LIMIT}$	Current limit corresponding to VLIM pin voltage range		0		8	A
$I_{LIM\_AC}$	Current limit accuracy		-10		10	%
$t_{BLANK}$	Cycle by cycle current limit blank time			5		$\mu\text{s}$
<b>ADVANCE ANGLE</b>						
$\theta_{ADV}$	Advance Angle Setting (SPI Device)	ADVANCE_LVL = 000 b		0		$^{\circ}$
		ADVANCE_LVL = 001 b		4		$^{\circ}$
		ADVANCE_LVL = 010 b		7		$^{\circ}$
		ADVANCE_LVL = 011 b		11		$^{\circ}$
		ADVANCE_LVL = 100 b		15		$^{\circ}$
		ADVANCE_LVL = 101 b		20		$^{\circ}$
		ADVANCE_LVL = 110 b		25		$^{\circ}$
		ADVANCE_LVL = 111 b		30		$^{\circ}$
$\theta_{ADV}$	Advance Angle Setting (HW Device)	Advance pin tied to AGND		0		$^{\circ}$
		Advance pin tied to $22\text{ k}\Omega \pm 5\%$ to AGND		4		$^{\circ}$
		Advance pin tied to $100\text{ k}\Omega \pm 5\%$ to AGND		11		$^{\circ}$
		Advance pin tied to Hi-Z		15		$^{\circ}$
		Advance pin tied to $100\text{ k}\Omega \pm 5\%$ to AVDD		20		$^{\circ}$
		Advance pin tied to $22\text{ k}\Omega \pm 5\%$ to AVDD		25		$^{\circ}$
		Advance pin tied to Tied to AVDD		30		$^{\circ}$
<b>PROTECTION CIRCUITS</b>						
$V_{UVLO}$	Supply undervoltage lockout (UVLO)	VM rising	4.3	4.4	4.5	V
		VM falling	4.1	4.2	4.3	V
$V_{UVLO\_HYS}$	Supply undervoltage lockout hysteresis	Rising to falling threshold	140	200	350	mV
$t_{UVLO}$	Supply undervoltage deglitch time		3	5	7	$\mu\text{s}$
$V_{OVP}$	Supply overvoltage protection (OVP) (SPI Device)	Supply rising, OVP_EN = 1, OVP_SEL = 0	32.5	34	35	V
		Supply falling, OVP_EN = 1, OVP_SEL = 0	31.8	33	34.3	V
		Supply rising, OVP_EN = 1, OVP_SEL = 1	20	22	23	V
		Supply falling, OVP_EN = 1, OVP_SEL = 1	19	21	22	V
$V_{OVP\_HYS}$	Supply overvoltage protection (OVP) (SPI Device)	Rising to falling threshold, OVP_SEL = 1	0.9	1	1.1	V
		Rising to falling threshold, OVP_SEL = 0	0.7	0.8	0.9	V
$t_{OVP}$	Supply overvoltage deglitch time		2.5	5	7	$\mu\text{s}$
$V_{CPUV}$	Charge pump undervoltage lockout (above VM)	Supply rising	2.3	2.5	2.7	V
		Supply falling	2.2	2.4	2.6	V
$V_{CPUV\_HYS}$	Charge pump UVLO hysteresis	Rising to falling threshold	75	100	140	mV
$V_{AVDD\_UV}$	Analog regulator undervoltage lockout	Supply rising	2.7	2.85	3	V
		Supply falling	2.5	2.65	2.8	V
$V_{AVDD\_UV\_HYS}$	Analog regulator undervoltage lockout hysteresis	Rising to falling threshold	180	200	240	mV

$T_J = -40^{\circ}\text{C}$  to  $+150^{\circ}\text{C}$ ,  $V_{VM} = 4.5$  to  $35\text{ V}$  (unless otherwise noted). Typical limits apply for  $T_A = 25^{\circ}\text{C}$ ,  $V_{VM} = 24\text{ V}$ 

PARAMETER		TEST CONDITIONS	MIN	TYP	MAX	UNIT
$I_{OCP}$	Overcurrent protection trip point (SPI Device)	OCP_LVL = 0b	10	16	20	A
		OCP_LVL = 1b	15	24	28	A
	Overcurrent protection trip point (HW Device)	OCP pin tied to AGND	10	16	21.5	A
		OCP pin tied to AVDD	15	24	31	A
$t_{OCP}$	Overcurrent protection deglitch time (SPI Device)	OCP_DEG = 00b	0.06	0.3	0.6	$\mu\text{s}$
		OCP_DEG = 01b	0.3	0.6	1.1	$\mu\text{s}$
		OCP_DEG = 10b	0.7	1.25	1.8	$\mu\text{s}$
		OCP_DEG = 11b	1.1	1.6	2.5	$\mu\text{s}$
	Overcurrent protection deglitch time (HW Device)		0.06	0.3	0.6	$\mu\text{s}$
$t_{RETRY}$	Overcurrent protection retry time (SPI Device)	OCP_RETRY = 0	4	5	6	ms
		OCP_RETRY = 1	450	500	560	ms
$t_{RETRY}$	Overcurrent protection retry time (HW Device)		4	5	6	ms
$t_{MTR\_LOCK}$	Motor lock detection time (SPI Device)	MOTOR_LOCK_TDET = 00b	270	300	330	ms
		MOTOR_LOCK_TDET = 01b	450	500	550	ms
		MOTOR_LOCK_TDET = 10b	900	1000	1100	ms
		MOTOR_LOCK_TDET = 11b	4500	5000	5500	ms
$t_{MTR\_LOCK}$	Motor lock detection time (HW Device)		900	1000	1100	ms
$t_{MTR\_LOCK\_RETRY}$	Motor lock retry time (SPI Device)	MOTOR_LOCK_RETRY = 0b	450	500	550	ms
		MOTOR_LOCK_RETRY = 1b	4500	5000	5500	ms
$t_{MTR\_LOCK\_RETRY}$	Motor lock retry time (HW Device)		450	500	550	ms
$T_{OTW}$	Thermal warning temperature (FET)	Die temperature ( $T_J$ )	160	170	180	$^{\circ}\text{C}$
$T_{OTW\_HYS}$	Thermal warning hysteresis (FET)	Die temperature ( $T_J$ )	25	30	35	$^{\circ}\text{C}$
$T_{TSD}$	Thermal shutdown temperature	Die temperature ( $T_J$ )	175	185	195	$^{\circ}\text{C}$
$T_{TSD\_HYS}$	Thermal shutdown hysteresis	Die temperature ( $T_J$ )	25	30	35	$^{\circ}\text{C}$
$T_{TSD}$	Thermal shutdown temperature (FET)	Die temperature ( $T_J$ )	170	180	190	$^{\circ}\text{C}$
$T_{TSD\_HYS}$	Thermal shutdown hysteresis (FET)	Die temperature ( $T_J$ )	25	30	35	$^{\circ}\text{C}$

 (1)  $R_{LBK}$  is resistance of inductor  $L_{BK}$ 

## 7.6 SPI Timing Requirements

		MIN	NOM	MAX	UNIT
$t_{READY}$	SPI ready after power up			1	ms
$t_{HI\_nSCS}$	nSCS minimum high time	300			ns
$t_{SU\_nSCS}$	nSCS input setup time	25			ns
$t_{HD\_nSCS}$	nSCS input hold time	25			ns
$t_{SCLK}$	SCLK minimum period	100			ns
$t_{SCLKH}$	SCLK minimum high time	50			ns
$t_{SCLKL}$	SCLK minimum low time	50			ns
$t_{SU\_SDI}$	SDI input data setup time	25			ns
$t_{HD\_SDI}$	SDI input data hold time	25			ns
$t_{DLY\_SDO}$	SDO output data delay time			25	ns
$t_{EN\_SDO}$	SDO enable delay time			50	ns

		MIN	NOM	MAX	UNIT
t <sub>DIS_SDO</sub>	SDO disable delay time			50	ns

### 7.7 SPI Secondary Mode Timings



图 7-1. SPI Secondary Mode Timing Diagram

### 7.8 Typical Characteristics



图 7-2. Supply current over supply voltage

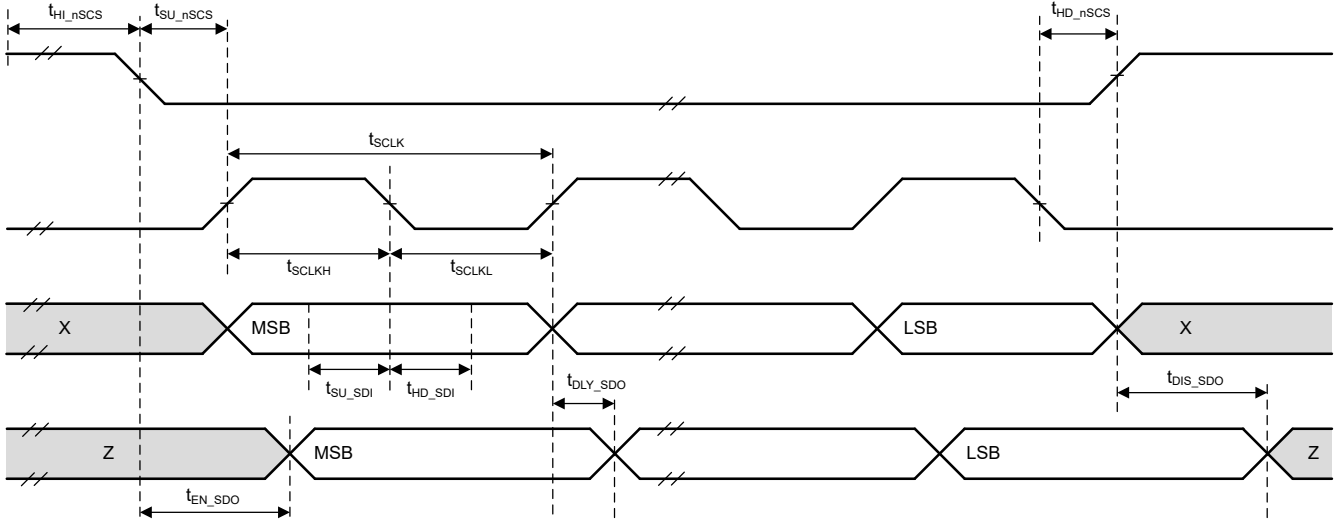

图 7-3. R<sub>DS(ON)</sub> (high and low side combined) for MOSFETs over temperature

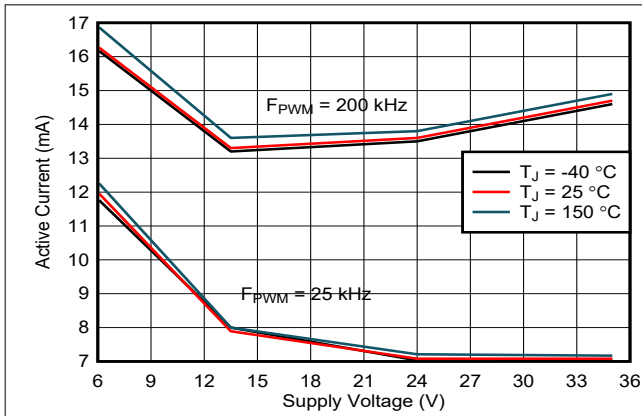

**图 7-4. Buck regulator efficiency over supply voltage**

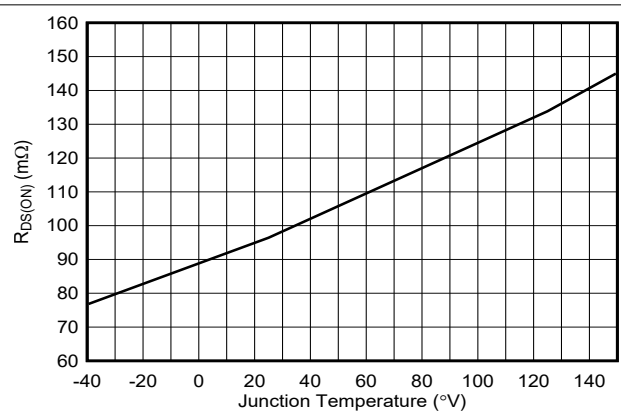
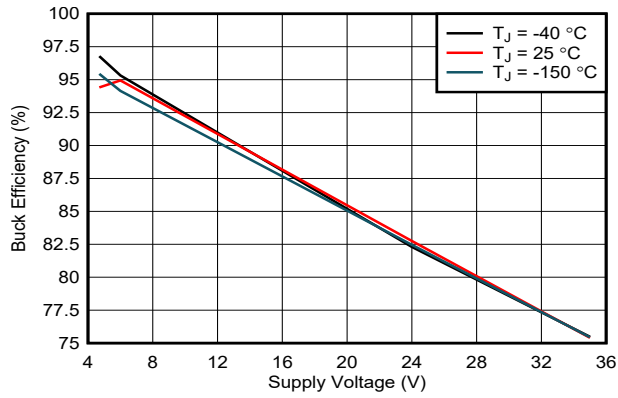
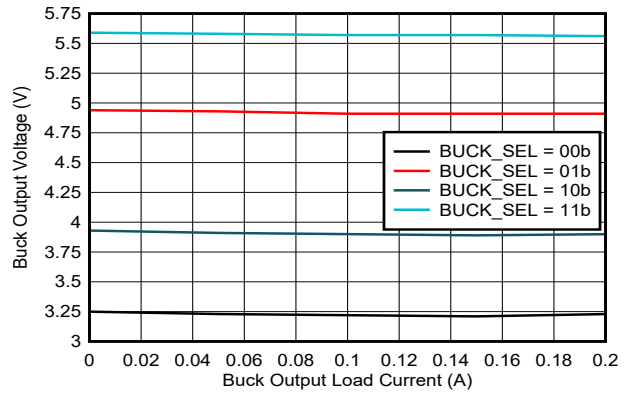

**图 7-5. Buck regulator output voltage over load current**

## 8 Detailed Description

### 8.1 Overview

The MCT8316Z device is an integrated 100-m $\Omega$  (combined high-side and low-side MOSFET's on-state resistance) driver for 3-phase motor-drive applications. The device reduces system component count, cost, and complexity by integrating three half-bridge MOSFETs, gate drivers, charge pump, linear regulator for the external load and buck regulator. A standard serial peripheral interface (SPI) provides a simple method for configuring the various device settings and reading fault diagnostic information through an external controller. Alternatively, a hardware interface (H/W) option allows for configuring the most commonly used settings through fixed external resistors.

The architecture uses an internal state machine to protect against short-circuit events, and protect against dv/dt parasitic turnon of the internal power MOSFET.

The MCT8316Z device integrates three-phase sensed trapezoidal commutation using analog or digital hall sensors for position detection.

In addition to the high level of device integration, the MCT8316Z device provides a wide range of integrated protection features. These features include power-supply undervoltage lockout (UVLO), charge-pump undervoltage lockout (CPUV), overcurrent protection (OCP), AVDD undervoltage lockout (AVDD\_UV), buck regulator ULVO for MCT8316ZR/T and overtemperature shutdown (OTW and OTSD). Fault events are indicated by the nFAULT pin with detailed information available in the SPI registers on the SPI device version.

The MCT8316ZT and MCT8316ZR device are available in 0.5-mm pin pitch, VQFN surface-mount packages. The VQFN package size is 7 mm  $\times$  5 mm.

## 8.2 Functional Block Diagram



图 8-1. MCT8316ZR Block Diagram



图 8-2. MCT8316ZT Block Diagram

## 8.3 Feature Description

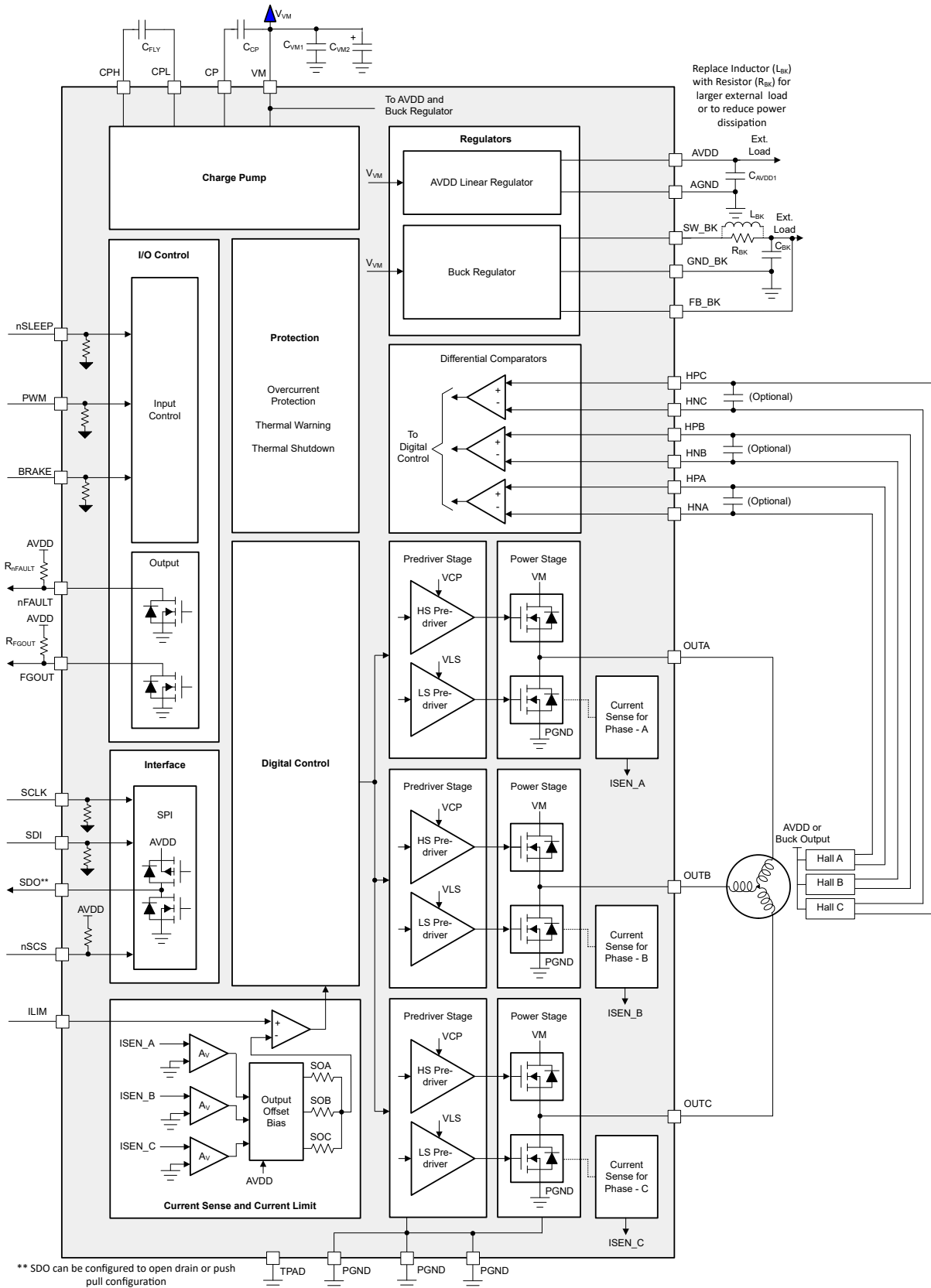
表 8-1 lists the recommended values of the external components for the driver.

### Note

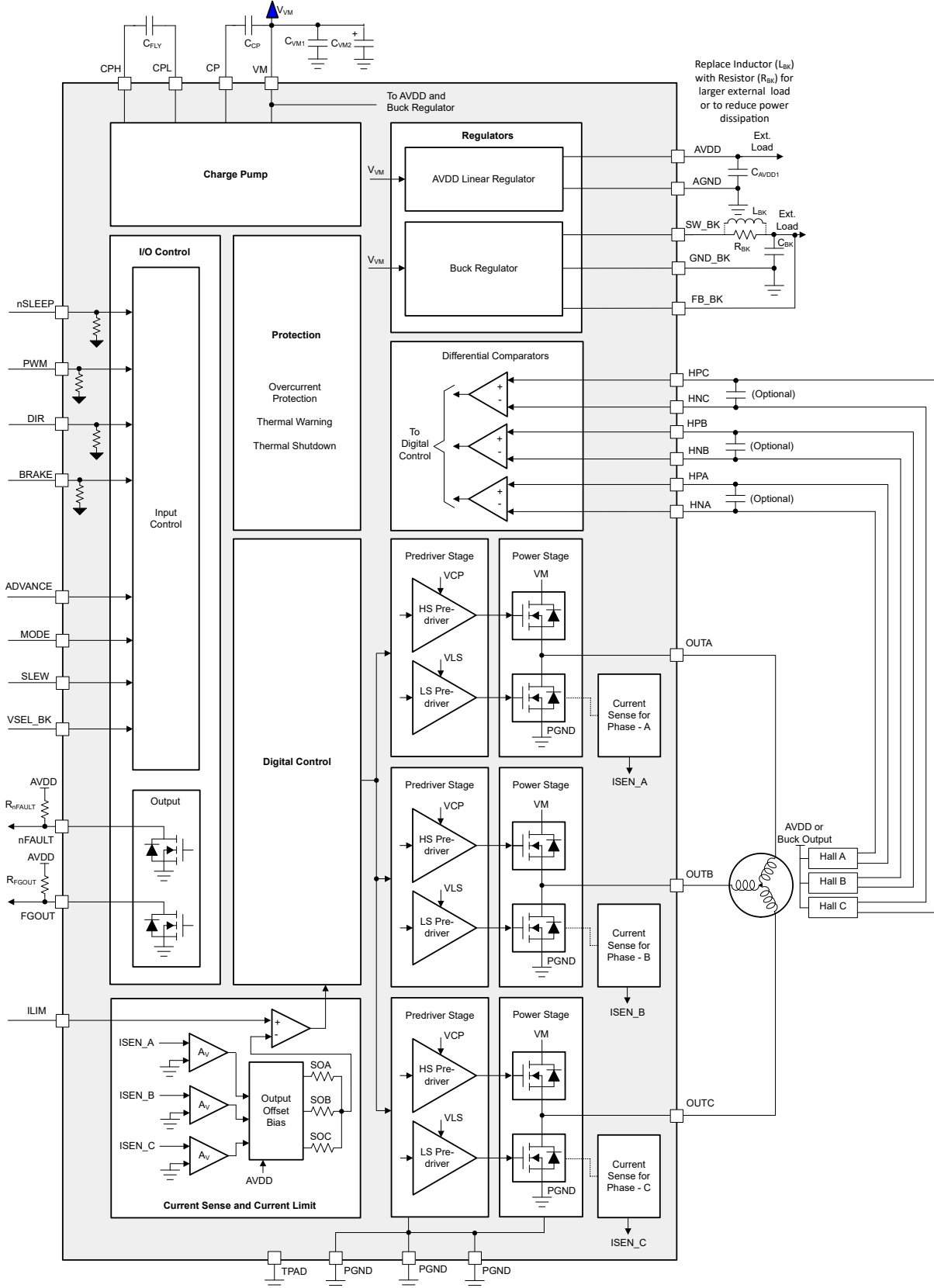
TI recommends to connect pull up on nFAULT even if it is not used to avoid undesirable entry into internal test mode. If external supply is used to pull up nFAULT, ensure that it is pulled to >2.2V on power up or the device will enter internal test mode.

表 8-1. MCT8316Z External Components

COMPONENTS	PIN 1	PIN 2	RECOMMENDED
C <sub>VM1</sub>	VM	PGND	X5R or X7R, 0.1-μF, TI recommends a capacitor voltage rating at least twice the normal operating voltage of the device
C <sub>VM2</sub>	VM	PGND	≥ 10-μF, TI recommends a capacitor voltage rating at least twice the normal operating voltage of the device
C <sub>CP</sub>	CP	VM	X5R or X7R, 16-V, 1-μF capacitor
C <sub>FLY</sub>	CPH	CPL	X5R or X7R, 47-nF, TI recommends a capacitor voltage rating at least twice the normal operating voltage of the pin
C <sub>AVDD</sub>	AVDD	AGND	X5R or X7R, 1-μF, ≥ 6.3-V. In order for AVDD to accurately regulate output voltage, capacitor should have effective capacitance between 0.7-μF to 1.3-μF at 3.3-V across operating temperature.
C <sub>BK</sub>	SW_BK	GND_BK	X5R or X7R, 22-μF, buck-output rated capacitor. TI recommends a capacitor voltage rating at least twice the normal operating voltage of the pin
L <sub>BK</sub>	SW_BK	FB_BK	Output inductor
R <sub>nFAULT</sub>	VCC	nFAULT	5.1-kΩ, Pullup resistor
R <sub>MODE</sub>	MODE	AGND or AVDD	MCT8316Z hardware interface
R <sub>SLEW</sub>	SLEW	AGND or AVDD	MCT8316Z hardware interface
R <sub>ADVANCE</sub>	ADVANCE	AGND or AVDD	MCT8316Z hardware interface
R <sub>VSEL_BK</sub>	VSEL_BK	AGND or AVDD	MCT8316Z hardware interface
C <sub>ILIM</sub>	ILIM	AGND	X5R or X7R, 0.1-μF, AVDD-rated capacitor (Optional)

### 8.3.1 Output Stage

The MCT8316Z device consists of an integrated 100-mΩ (combined high-side and low-side FET's on-state resistance) NMOS FETs connected in a three-phase bridge configuration. A doubler charge pump provides the proper gate-bias voltage to the high-side NMOS FET's across a wide operating-voltage range in addition to providing 100% duty-cycle support. An internal linear regulator provides the gate-bias voltage for the low-side MOSFETs. The device has three VM motor power-supply pins which are to be connected together to the motor-supply voltage.

### 8.3.2 PWM Control Mode (1x PWM Mode)

The MCT8316Z family of devices provides seven different control modes to support various commutation and control methods. The MCT8316Z device provides a 1x PWM control mode for driving the BLDC motor in trapezoidal current-control mode. The MCT8316Z device uses 6-step block commutation tables that are stored internally. This feature lets a three-phase BLDC motor be controlled using a single PWM sourced from a simple controller. The PWM is applied on the PWM pin and determines the output frequency and duty cycle of the half-bridges.

The MCT8316Z family of devices supports both analog and digital hall inputs by changing mode input setting. Differential hall inputs should be connected to HPx and HNx pins (see 图 8-3). Digital hall inputs should be connected to the HPx pins while keeping the HNx pins floating (see 图 8-4).

The half-bridge output states are managed by the HPA, HNA, HPB, HNB, HPC and HNC pins in analog mode and HPA, HPB, HPC in digital mode which are used as state logic inputs. The state inputs are the position feedback of the BLDC motor. The 1x PWM mode usually operates with synchronous rectification (low-side MOSFET recirculation); however, the mode can be configured to use asynchronous rectification (MOSFET body diode freewheeling) as shown below

**表 8-2. PWM\_MODE Configuration**

MODE Type	MODE Pin (Hardware Variant)	Hall Configuration	Modulation	ASR and AAR Mode
Mode 1	Connected to AGND	Analog Hall Input	Asynchronous	ASR and AAR Disabled
Mode 2	Connected to AGND with R <sub>MODE1</sub>	Digital Hall Input	Asynchronous	ASR and AAR Disabled
Mode 3	Connected to AGND with R <sub>MODE2</sub>	Analog Hall Input	Synchronous	ASR and AAR Disabled
Mode 4	Hi-Z	Digital Hall Input	Synchronous	ASR and AAR Disabled
Mode 5	Connected to AVDD with R <sub>MODE2</sub>	Analog Hall Input	Synchronous	ASR and AAR Enabled
Mode 6	Connected to AVDD with R <sub>MODE1</sub>	Digital Hall Input	Synchronous	ASR and AAR Enabled
Mode 7	Connected to AVDD			

**Note**

Texas Instruments does not recommend changing the MODE pin or PWM\_MODE register during operation of the power MOSFETs. Set PWM to a low level before changing the MODE pin or PWM\_MODE register.

### 8.3.2.1 Analog Hall Input Configuration

图 8-3 shows the connection of Analog Hall inputs to the driver. Analog hall elements are fed to the hall comparators, which zero crossing is used to generate the commutation logic.



图 8-3. 1x PWM Mode with Analog Hall Input

**Note**

Texas Instruments recommends motor direction (DIR) change when the motor is stationary.

### 8.3.2.2 Digital Hall Input Configuration

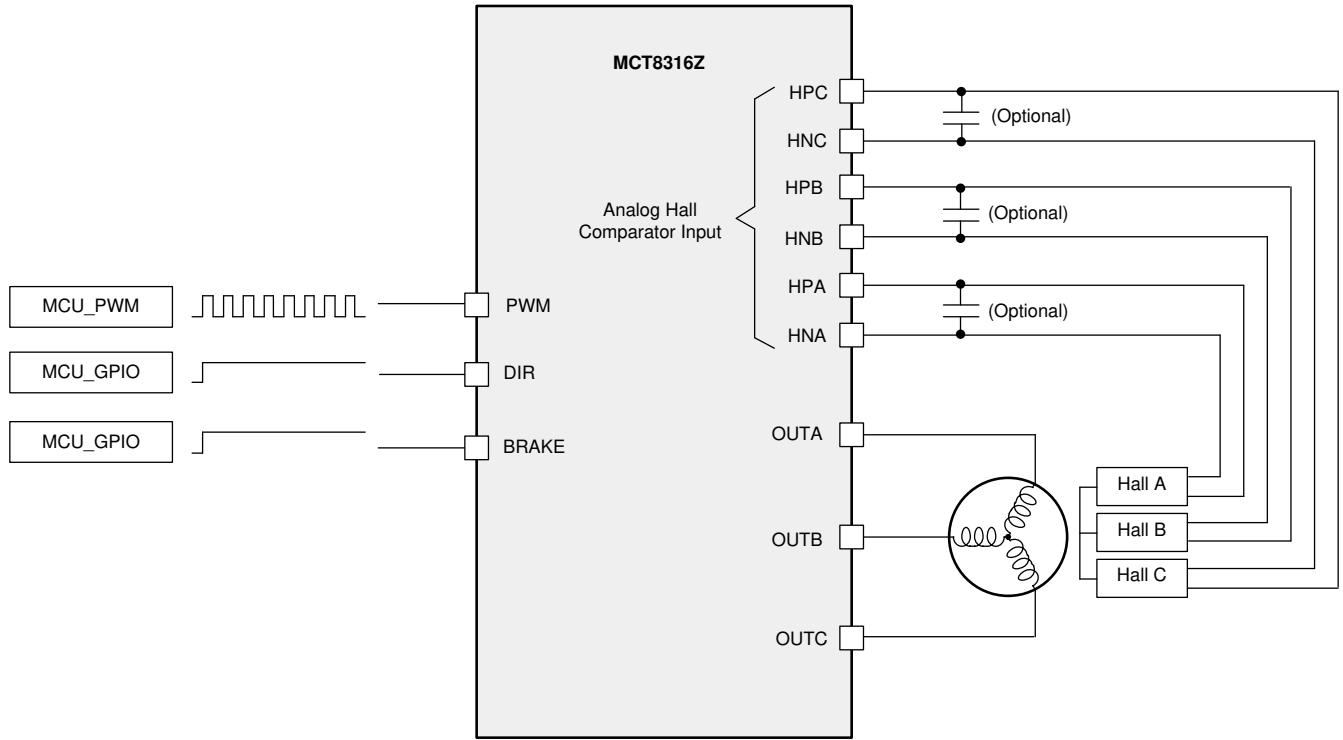
图 8-4 shows the connection of Digital Hall inputs to the driver.



图 8-4. 1x PWM Mode with Digital Hall Input

### 8.3.2.3 Asynchronous Modulation

The DIR pin controls the direction of BLDC motor in either clockwise or counter-clockwise direction. Tie the DIR pin low if this feature is not required.

The BRAKE input halts the motor by turning off all high-side MOSFETs and turning on all low-side MOSFETs when it is pulled high. This brake is independent of the states of the other input pins. Tie the BRAKE pin low if this feature is not required.

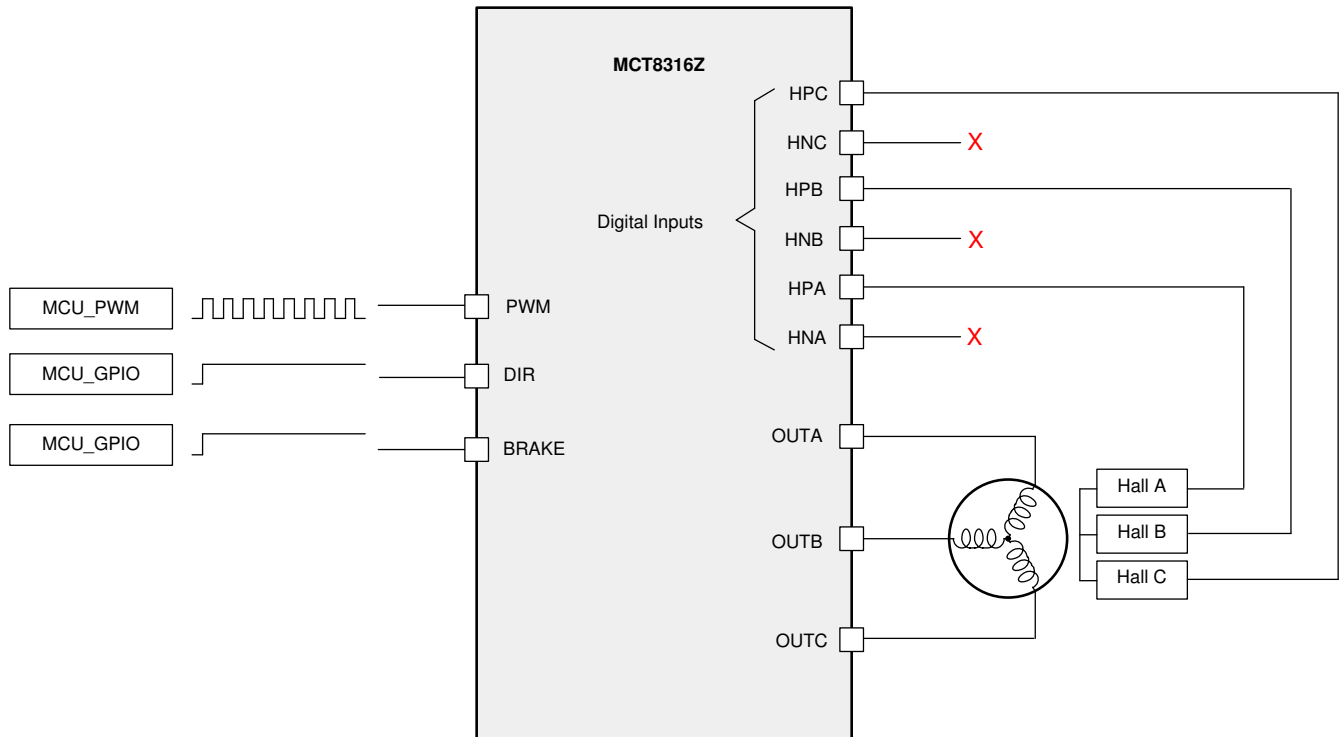
表 8-3 shows the configuration in 1x PWM mode with asynchronous modulation.

表 8-3. Asynchronous Modulation

STATE	HALL INPUTS						DRIVER OUTPUTS						DESCRIPTION
	DIR = 0			DIR = 1			PHASE A		PHASE B		PHASE C		
	HALL_A /HPA	HALL_B /HPB	HALL_C /HPC	HALL_A /HPA	HALL_B /HPB	HALL_C /HPC	High Side	Low Side	High Side	Low Side	High Side	Low Side	
Stop	0	0	0	0	0	0	L	L	L	L	L	L	Stop
Align	1	1	1	1	1	1	PWM	L	L	H	L	H	Align
1	1	1	0	0	0	1	L	L	PWM	L	L	H	B → C
2	1	0	0	0	1	1	PWM	L	L	L	L	H	A → C
3	1	0	1	0	1	0	PWM	L	L	H	L	L	A → B
4	0	0	1	1	1	0	L	L	L	H	PWM	L	C → B
5	0	1	1	1	0	0	L	H	L	L	PWM	L	C → A
6	0	1	0	1	0	1	L	H	PWM	L	L	L	B → A

### 8.3.2.4 Synchronous Modulation

表 8-4 shows the configuration in 1x PWM mode with synchronous modulation.

表 8-4. Synchronous Modulation

STATE	HALL INPUTS						DRIVER OUTPUTS						DESCRIPTION
	DIR = 0			DIR = 1			PHASE A		PHASE B		PHASE C		
	HALL_A /HPA	HALL_B /HPB	HALL_C /HPC	HALL_A /HPA	HALL_B /HPB	HALL_C /HPC	High Side	Low Side	High Side	Low Side	High Side	Low Side	
Stop	0	0	0	0	0	0	L	L	L	L	L	L	Stop
Align	1	1	1	1	1	1	PWM	!PWM	L	H	L	H	Align
1	1	1	0	0	0	1	L	L	PWM	!PWM	L	H	B → C
2	1	0	0	0	1	1	PWM	!PWM	L	L	L	H	A → C
3	1	0	1	0	1	0	PWM	!PWM	L	H	L	L	A → B
4	0	0	1	1	1	0	L	L	L	H	PWM	!PWM	C → B
5	0	1	1	1	0	0	L	H	L	L	PWM	!PWM	C → A
6	0	1	0	1	0	1	L	H	PWM	!PWM	L	L	B → A

### 8.3.2.5 Motor Operation

图 8-5 and 图 8-6 shows the BLDC motor commutation with direction setting (DIR) as 0 and 1 respectively.



图 8-5. BLDC Motor Commutation with DIR = 0



图 8-6. BLDC Motor Commutation with DIR = 1

### 8.3.3 Device Interface Modes

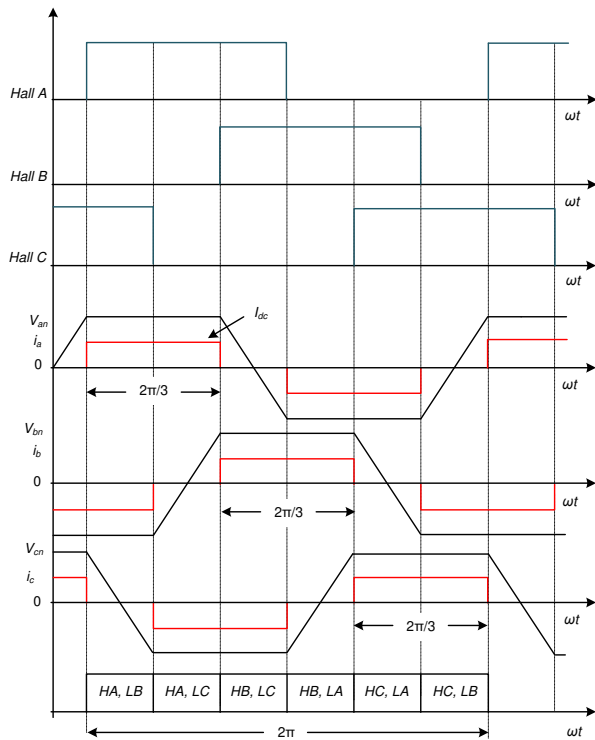
The MCT8316Z family of devices supports two different interface modes (SPI and hardware) to let the end application design for either flexibility or simplicity. The two interface modes share the same four pins, allowing the different versions to be pin-to-pin compatible. This compatibility lets application designers evaluate with one interface version and potentially switch to another with minimal modifications to their design.

#### 8.3.3.1 Serial Peripheral Interface (SPI)

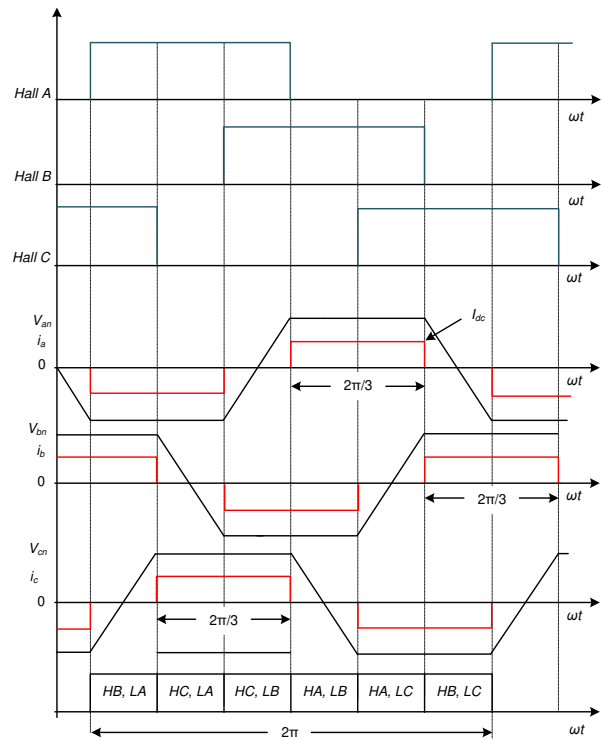
The SPI devices support a serial communication bus that lets an external controller send and receive data with the MCT8316Z. This support lets the external controller configure device settings and read detailed fault information. The interface is a four wire interface using the SCLK, SDI, SDO, and nSCS pins which are described as follows:

- The SCLK pin is an input that accepts a clock signal to determine when data is captured and propagated on the SDI and SDO pins.
- The SDI pin is the data input.
- The SDO pin is the data output. The SDO pin can be configured to either open-drain or push-pull through SDO\_MODE.
- The nSCS pin is the chip select input. A logic low signal on this pin enables SPI communication with the MCT8316Z.

For more information on the SPI, see the [§ 8.5](#) section.

#### 8.3.3.2 Hardware Interface

Hardware interface devices convert the four SPI pins into four resistor-configurable inputs which are ADVANCE, MODE, SLEW and VSEL\_BK.

This conversion lets the application designer configure the most common device settings by tying the pin logic high or logic low, or with a simple pullup or pulldown resistor. This removes the requirement for an SPI bus from the external controller. General fault information can still be obtained through the nFAULT pin.

- The MODE pin configures the PWM control mode.
- The SLEW pin configures the slew rate of the output voltage.
- The ADVANCE pin configures the lead angle of the output with respect to hall signals.
- The VSEL\_BK pin is used to configure the buck regulator voltage.

For more information on the hardware interface, see the [§ 8.3.10](#) section.



图 8-7. MCT8316ZR SPI Interface



图 8-8. MCT8316ZT Hardware Interface

### 8.3.4 Step-Down Mixed-Mode Buck Regulator

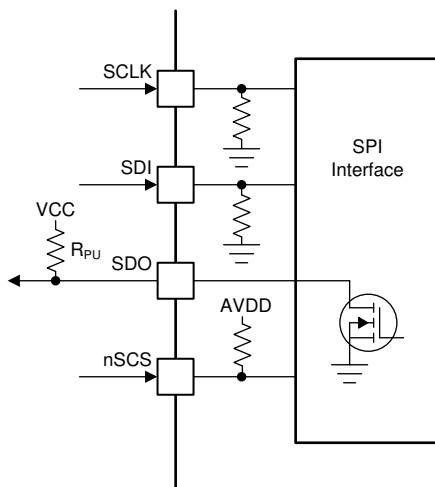
The MCT8316ZR and MCT8316ZT has an integrated mixed-mode buck regulator in conjunction with AVDD to supply regulated 3.3 V or 5.0 V power for an external controller or system voltage rail. Additionally, the buck output can also be configured to 4.0 V or 5.7 V for supporting the extra headroom for external LDO for generating a 3.3 V or 5.0 V supplies. The output voltage of the buck is set by the VSEL\_BK pin in the MCT8316ZT device (hardware variant) and BUCK\_SEL bits in the MCT8316ZR device (SPI variant).

The buck regulator has a low quiescent current of ~1-2 mA during light loads to prolong battery life. The device improves performance during line and load transients by implementing a pulse-frequency current-mode control scheme which requires less output capacitance and simplifies frequency compensation design.

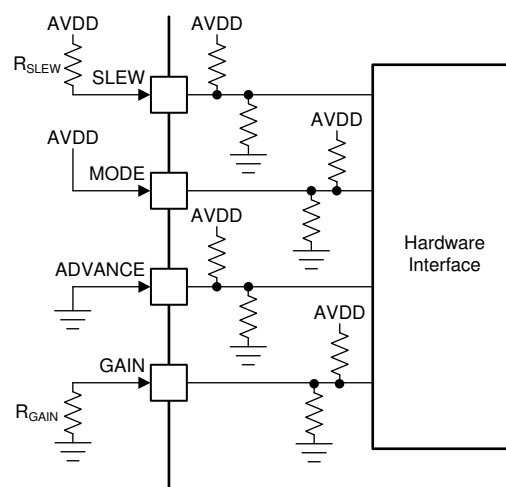
To disable the buck regulator, set the BUCK\_DIS bit in the MCT8316ZR (SPI variant). The buck regulator cannot be disabled in the MCT8316ZT (hardware variant).

#### Note

If the buck regulator is unused, the buck pins SW\_BK, GND\_BK, and FB\_BK cannot be left floating or connected to ground. The buck regulator components  $L_{BK}/R_{BK}$  and  $C_{BK}$  must be connected in hardware.

**表 8-5. Recommended settings for Buck Regulator**

Buck Mode	Buck output voltage	Max output current from AVDD ( $I_{AVDD}$ )	Max output current from Buck ( $I_{BK}$ )	Buck current limit	AVDD power sequencing
Inductor - 47 $\mu$ H	3.3 V or 4.0 V	30 mA	200 mA - $I_{AVDD}$	600 mA (BUCK_CL = 0b)	Not supported (BUCK_PS_DIS = 1)
Inductor - 47 $\mu$ H	5.0 V or 5.7 V	30 mA	200 mA - $I_{AVDD}$	600 mA (BUCK_CL = 0b)	Supported (BUCK_PS_DIS = 0)
Inductor - 22 $\mu$ H	5.0 V or 5.7 V	30 mA	50 mA - $I_{AVDD}$	150 mA (BUCK_CL = 1b)	Not supported (BUCK_PS_DIS = 1)
Inductor - 22 $\mu$ H	3.3 V or 4.0 V	30 mA	50 mA - $I_{AVDD}$	150 mA (BUCK_CL = 1b)	Supported (BUCK_PS_DIS = 0)
Resistor - 22 $\mu$ H	5.0 V or 5.7 V	30 mA	40 mA - $I_{AVDD}$	150 mA (BUCK_CL = 1b)	Not supported (BUCK_PS_DIS = 1)
Resistor - 22 $\mu$ H	3.3 V or 4.0 V	30 mA	40 mA - $I_{AVDD}$	150 mA (BUCK_CL = 1b)	Supported (BUCK_PS_DIS = 0)

### 8.3.4.1 Buck in Inductor Mode

The buck regulator in MCT8316Z device is primarily designed to support low inductance of  $47\mu\text{H}$  and  $22\mu\text{H}$  inductors. The  $47\mu\text{H}$  inductor allows the buck regulator to operate up to 200 mA load current support, whereas the  $22\mu\text{H}$  inductor limits the load current to 50 mA.

图 8-9 shows the connection of buck regulator in inductor mode.



图 8-9. Buck (Inductor Mode)

### 8.3.4.2 Buck in Resistor mode

If the external load requirements is less than 40mA, the inductor can be replaced with a resistor. In resistor mode the power is dissipated across the external resistor and the efficiency is lower than buck in inductor mode.

图 8-10 shows the connection of buck regulator in resistor mode.

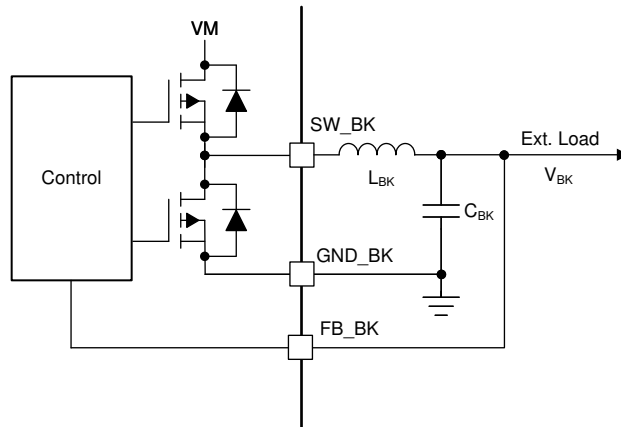

图 8-10. Buck (Resistor Mode)

### 8.3.4.3 Buck Regulator with External LDO

The buck regulator also supports the voltage requirement to feed to external LDO to generate standard 3.3 V or 5.0 V output rail with higher accuracies. The buck output voltage should be configured to 4 V or 5.5 V to provide for a extra headroom to support the external LDO for generating 3.3 V or 5 V rail as shown in [图 8-11](#).

This allows for a lower-voltage LDO design to save cost and better thermal management due to low drop-out voltage.

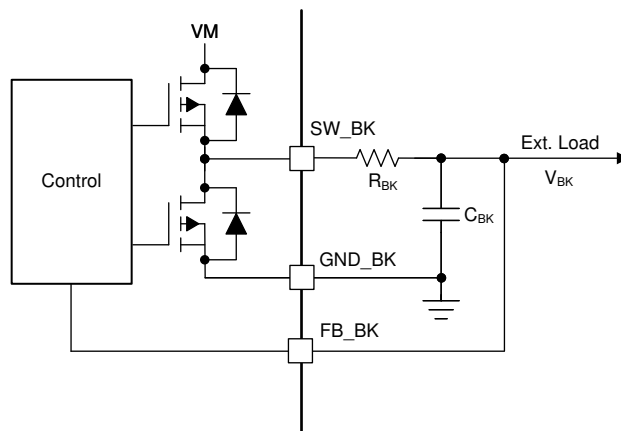
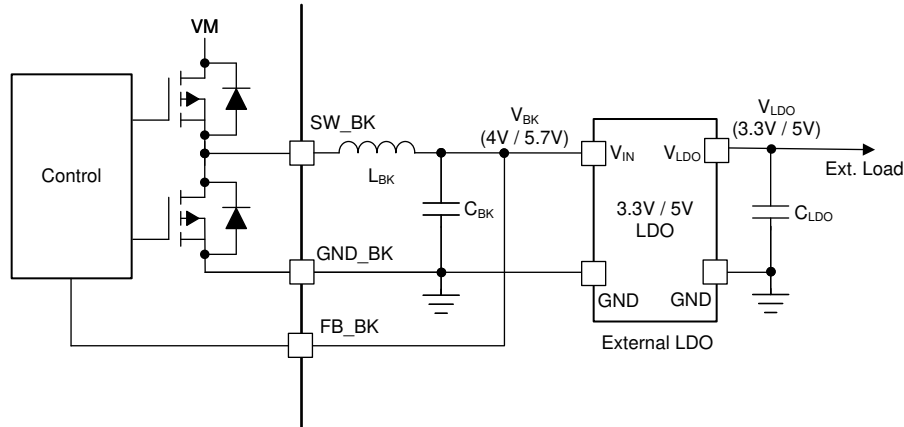

**图 8-11. Buck Regulator with External LDO**

### 8.3.4.4 AVDD Power Sequencing on Buck Regulator

The AVDD LDO has an option of using the power supply from mixed mode buck regulator to reduce power dissipation internally. The power sequencing mode allows on-the-fly changeover of LDO power supply from DC mains (VM) to buck output (VBK) as shown in [图 8-12](#). This sequencing can be configured through the BUCK\_PS\_DIS bit . Power sequencing is supported only when buck output voltage is set to 5.0 V or 5.7 V.



图 8-12. AVDD Power Sequencing on mixed mode Buck Regulator

### 8.3.4.5 Mixed mode Buck Operation and Control

The buck regulator implements a pulse frequency modulation (PFM) architecture with peak current mode control. The output voltage of the buck regulator is compared with the internal reference voltage ( $V_{BK\_REF}$ ) which is internally generated depending on the buck-output voltage setting (BUCK\_SEL) which constitutes an outer voltage control loop. Depending on the comparator output going high ( $V_{BK} < V_{BK\_REF}$ ) or low ( $V_{BK} > V_{BK\_REF}$ ), the high-side power FET of the buck turns on and turns off respectively. An independent current control loop monitors the current in high-side power FET ( $I_{BK}$ ) and turns off the high-side FET when the current becomes higher than the buck current limit ( $I_{BK\_CL}$ ). This implements a current limit control for the buck regulator. 图 8-13 shows the architecture of the buck and various control/protection loops.

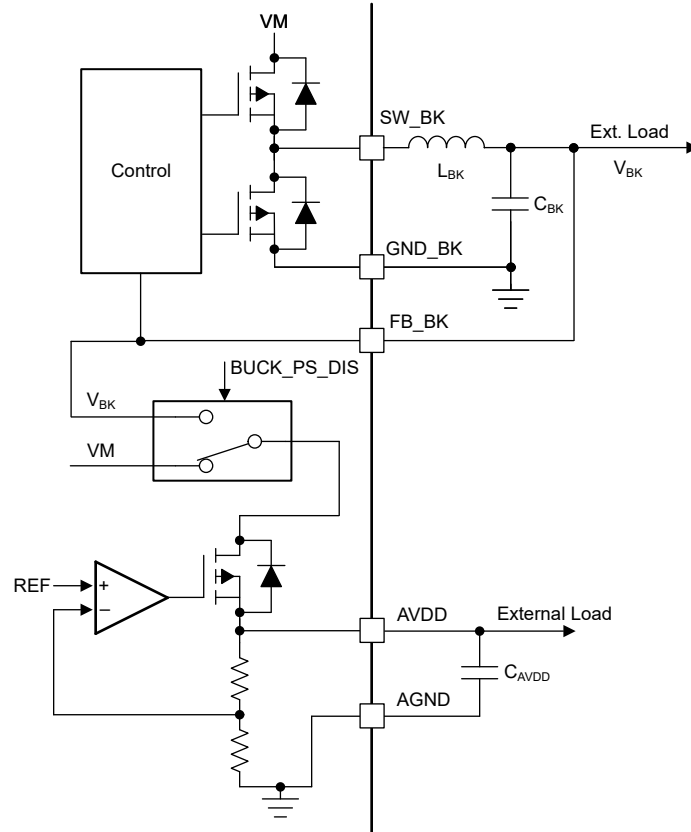

图 8-13. Buck Operation and Control Loops

### 8.3.5 AVDD Linear Voltage Regulator

A 3.3-V, linear regulator is integrated into the MCT8316Z family of devices and is available for use by external circuitry. The AVDD regulator is used for powering up the internal digital circuitry of the device and additionally, this regulator can also provide the supply voltage for a low-power MCU or other circuitry supporting low current (up to 30 mA). The output of the AVDD regulator should be bypassed near the AVDD pin with a X5R or X7R, 1- $\mu$ F, 6.3-V ceramic capacitor routed directly back to the adjacent AGND ground pin.

The AVDD nominal, no-load output voltage is 3.3V.

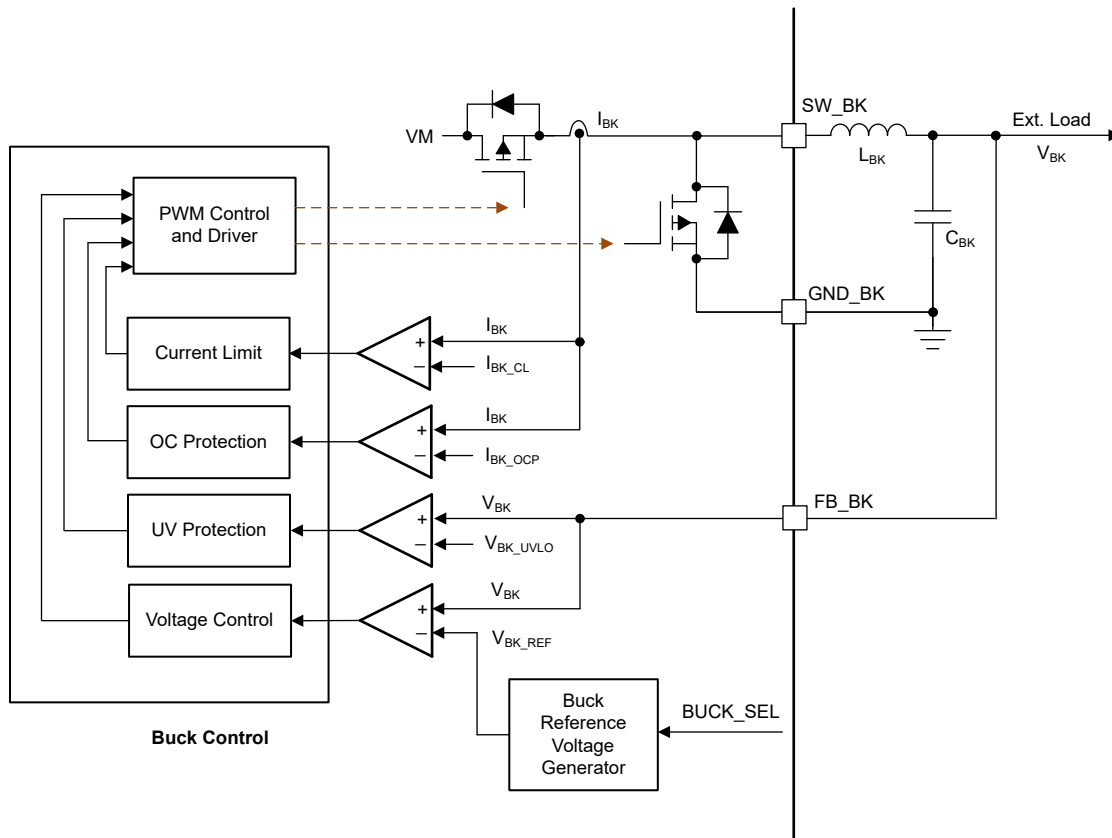

图 8-14. AVDD Linear Regulator Block Diagram

Use [方程式 1](#) to calculate the power dissipated in the device by the AVDD linear regulator with VM as supply (BUCK\_PD\_DIS = 1)

$$P = (V_{VM} - V_{AVDD}) \times I_{AVDD} \quad (1)$$

For example, at a V<sub>VM</sub> of 24 V, drawing 20 mA out of AVDD results in a power dissipation as shown in [方程式 2](#).

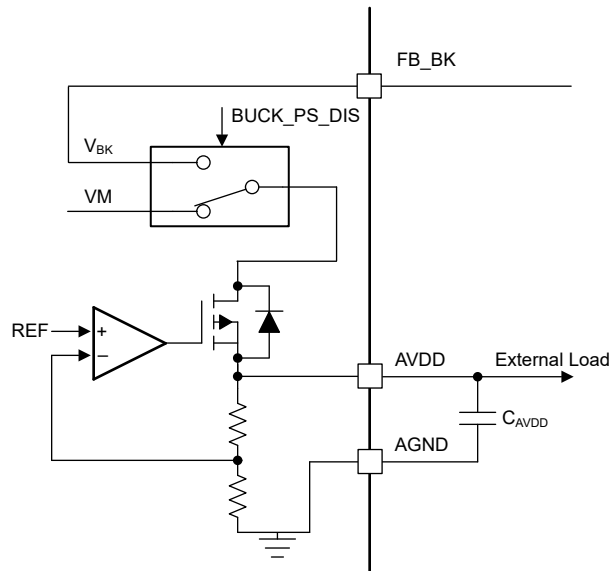
$$P = (24 \text{ V} - 3.3 \text{ V}) \times 20 \text{ mA} = 414 \text{ mW} \quad (2)$$

Use [方程式 3](#) to calculate the power dissipated in the device by the AVDD linear regulator with buck output as supply (BUCK\_PD\_DIS = 0)

$$P = (V_{FB\_BK} - V_{AVDD}) \times I_{AVDD} \quad (3)$$

### 8.3.6 Charge Pump

Because the output stages use N-channel FETs, the device requires a gate-drive voltage higher than the VM power supply to enhance the high-side FETs fully. The MCT8316Z integrates a charge-pump circuit that generates a voltage above the VM supply for this purpose.

The charge pump requires two external capacitors for operation. See the block diagram, pin descriptions and see section ( [节 8.3](#) ) for details on these capacitors (value, connection, and so forth).

The charge pump shuts down when nSLEEP is low.



图 8-15. MCT8316Z Charge Pump

### 8.3.7 Slew Rate Control

An adjustable gate-drive current control to the MOSFETs of half-bridges is implemented to achieve the slew rate control. The MOSFET VDS slew rates are a critical factor for optimizing radiated emissions, energy and duration of diode recovery spikes, and switching voltage transients related to parasitics. These slew rates are predominantly determined by the rate of gate charge to internal MOSFETs as shown in [图 8-16](#).

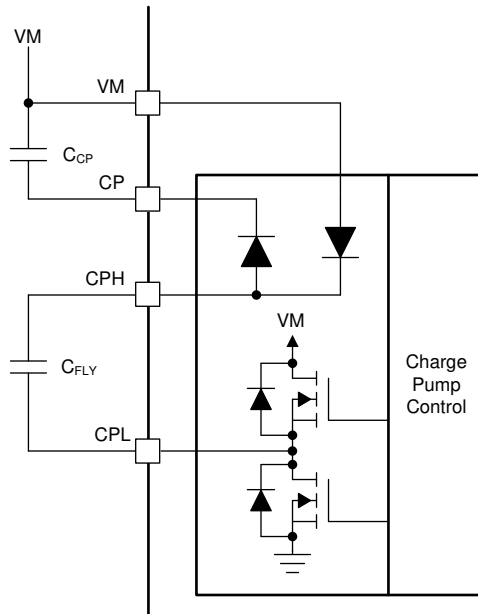
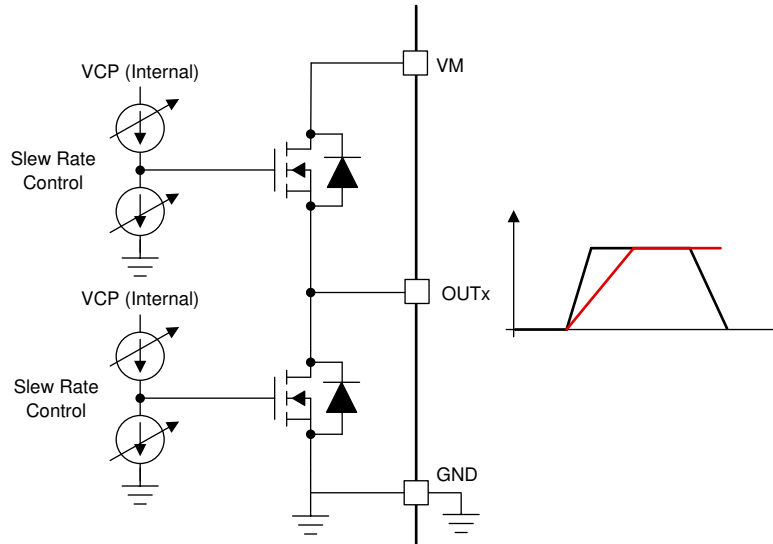

**图 8-16. Slew Rate Circuit Implementation**

The slew rate of each half-bridge can be adjusted by the SLEW pin in hardware device variant or by using the SLEW bits in SPI device variant. Each half-bridge can be selected to either of a slew rate setting of 25-V/ $\mu$ s, 50-V/ $\mu$ s, 125-V/ $\mu$ s or 200-V/ $\mu$ s. The slew rate is calculated by the rise time and fall time of the voltage on OUTx pin as shown in [图 8-17](#).

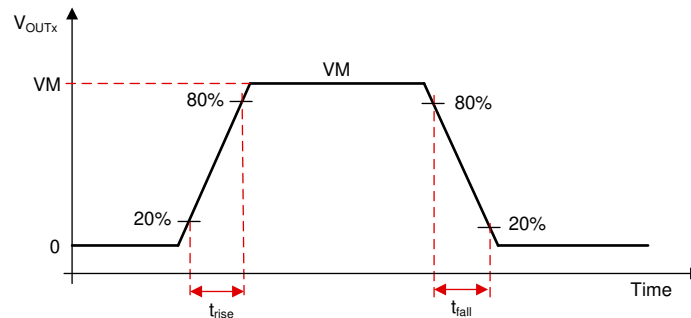

**图 8-17. Slew Rate Timings**

### 8.3.8 Cross Conduction (Dead Time)

The device is fully protected for any cross conduction of MOSFETs. In half-bridge configuration, the operation of high-side and low-side MOSFETs are ensured to avoid any shoot-through currents by inserting a dead time ( $t_{dead}$ ). This is implemented by sensing the gate-source voltage (VGS) of the high-side and low-side MOSFETs and ensuring that VGS of high-side MOSFET has reached below turn-off levels before switching on the low-side MOSFET of same half-bridge as shown in [图 8-18](#) and [图 8-19](#).

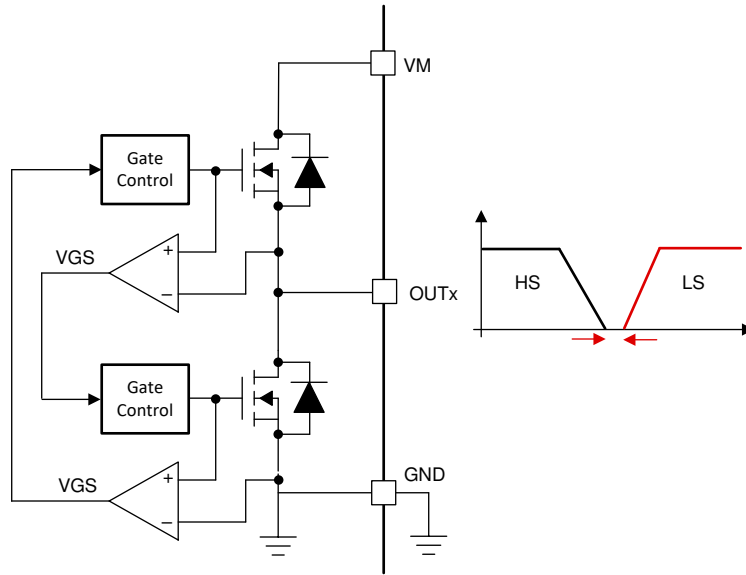

**图 8-18. Cross Conduction Protection**

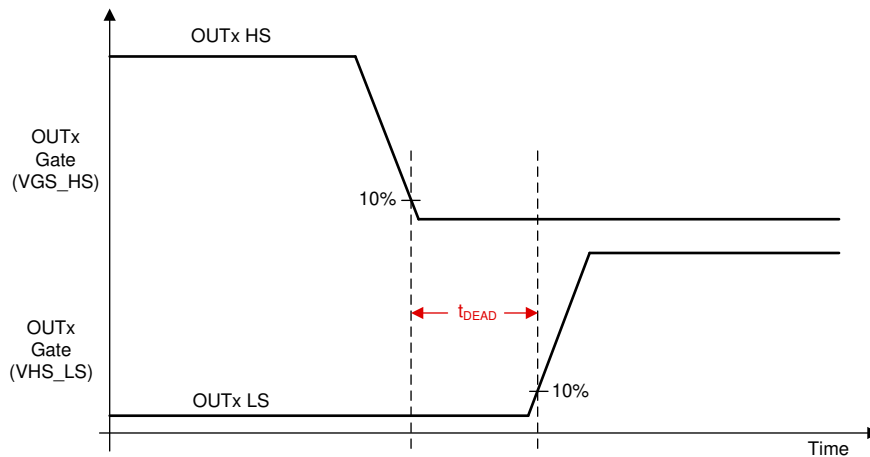

**图 8-19. Dead Time**

### 8.3.9 Propagation Delay

The propagation delay time ( $t_{pd}$ ) is measured as the time between an input logic edge to change in gate driver voltage. This time has three parts consisting of the digital input deglitcher delay, analog driver, and comparator delay.

The input deglitcher prevents high-frequency noise on the input pins from affecting the output state of the gate drivers. To support multiple control modes, a small digital delay is added as the input command propagates through the device.



图 8-20. Propagation Delay Timing

#### 8.3.9.1 Driver Delay Compensation

MCT8316Z monitors the propagation delay internally and adds a variable delay on top of it to provide fixed delay as shown in 图 8-21 and 图 8-22. Delay compensation feature reduces uncertainty caused in timing of current measurement and also reduces duty cycle distortion caused due to propagation delay.

The fixed delay is summation of propagation delay ( $t_{PD}$ ) caused to internal driver delay and variable delay ( $t_{VAR}$ ) added to compensate for uncertainty. The fixed delay can be configured through DLY\_TARGET register. Refer 表 8-6 for recommendation on configuration for DLY\_TARGET for different slew rate settings.

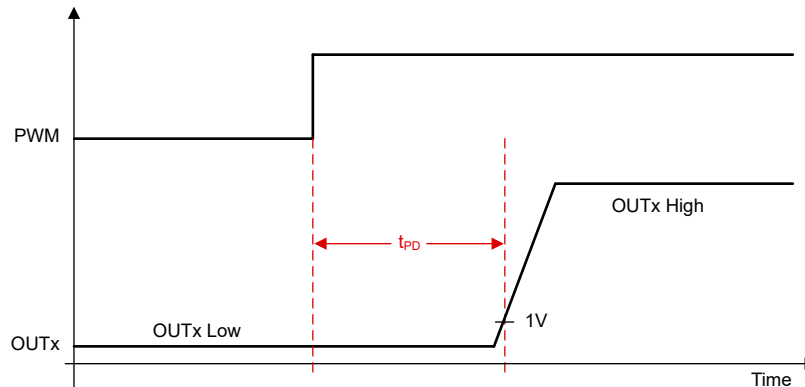
Delay compensation is only available in SPI variant MCT8316ZR and can be enabled by configuring DLYCMP\_EN and DLY\_TARGET. It is disabled in hardware variant MCT8316ZT



图 8-21. Delay Compensation with current flowing out of phase



图 8-22. Delay Compensation with current flowing into the phase

表 8-6. Delay Target Recommendation

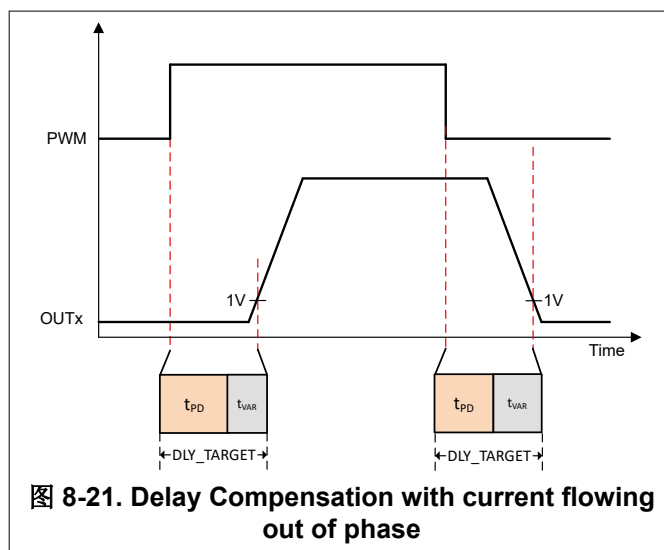
SLEW RATE	DLY_TARGET
200 V/ $\mu$ s	DLY_TARGET = 0x5 (1.2 $\mu$ s)
125 V/ $\mu$ s	DLY_TARGET = 0x8 (1.8 $\mu$ s)
50 V/ $\mu$ s	DLY_TARGET = 0xB (2.4 $\mu$ s)
25 V/ $\mu$ s	DLY_TARGET = 0xF (3.2 $\mu$ s)

### 8.3.10 Pin Diagrams

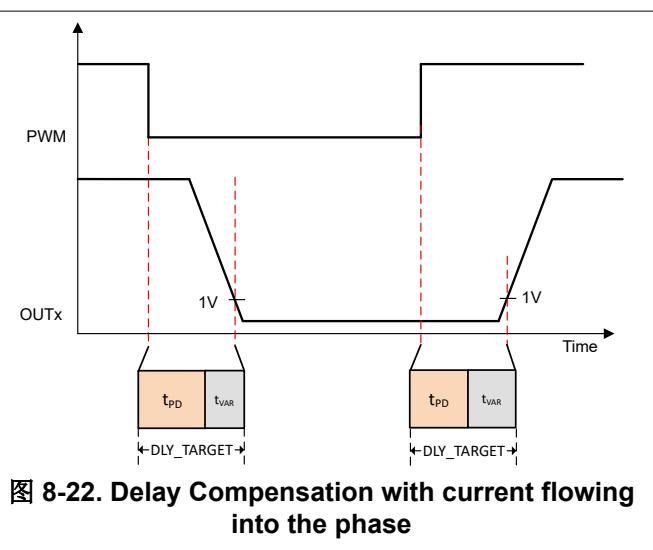
This section presents the I/O structure of all digital input and output pins.

#### 8.3.10.1 Logic Level Input Pin (Internal Pulldown)

图 8-23 shows the input structure for the logic level pins, BRAKE, DIR, DRVOFF, nSLEEP, PWM, SCLK and SDI. The input can be with a voltage or external resistor. It is recommended to put these pins low in device sleep mode to reduce leakage current through internal pull-down resistors.



图 8-23. Logic-Level Input Pin Structure

#### 8.3.10.2 Logic Level Input Pin (Internal Pullup)

图 8-24 shows the input structure for the logic level pin, nSCS. The input can be driven with a voltage or external resistor.

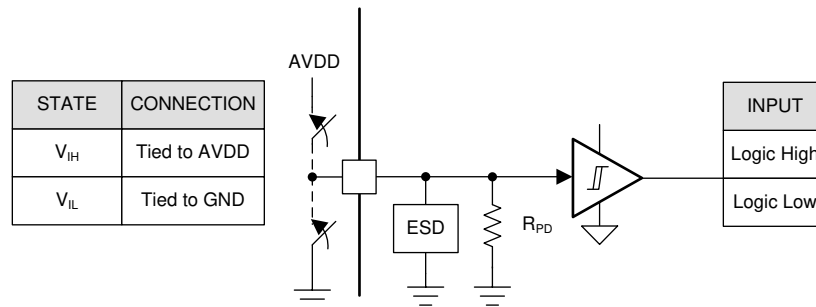

图 8-24. Logic nSCC

#### 8.3.10.3 Open Drain Pin

图 8-25 shows the structure of the open-drain output pins, nFAULT, FGOUT and SDO in open drain mode. The open-drain output requires an external pullup resistor to function properly.

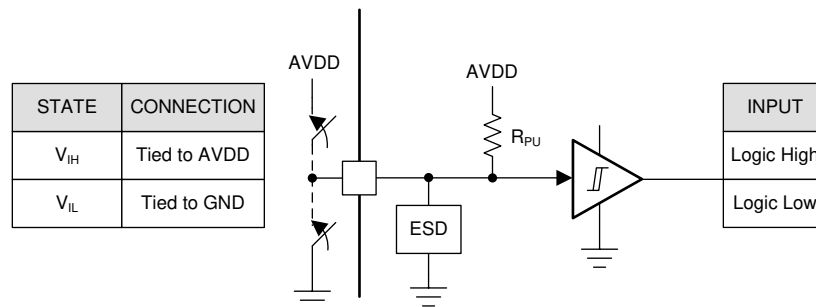

图 8-25. Open Drain

8.3.10.4 Push Pull Pin

图 8-26 shows the structure of SDO in push-pull mode.

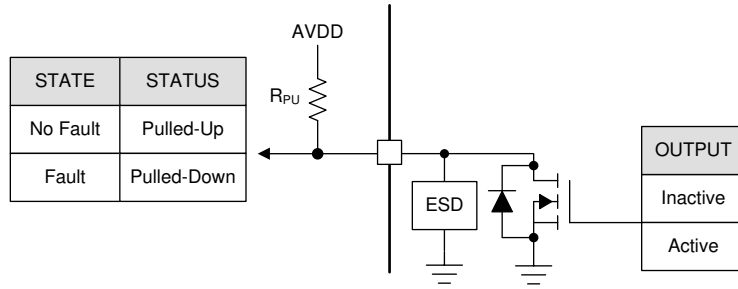

图 8-26. Push Pull

8.3.10.5 Four Level Input Pin

图 8-27 shows the structure of the four level input pins, SLEW and VSEL\_BK on hardware interface devices. The input can be set with an external resistor.

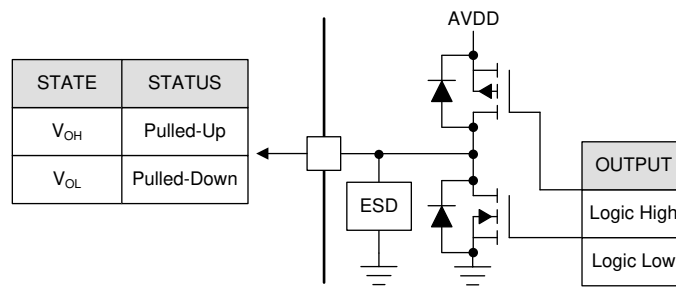

图 8-27. Four Level Input Pin Structure

### 8.3.10.6 Seven Level Input Pin

图 8-28 shows the structure of the seven level input pins, ADVANCE and MODE, on hardware interface devices. The input can be set with an external resistor.

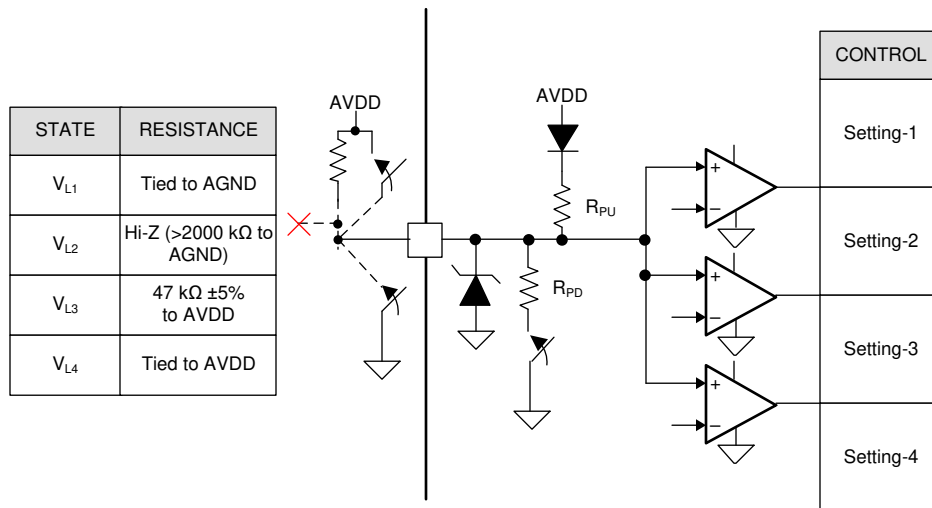

图 8-28. Seven Level Input Pin Structure

### 8.3.11 Active Demagnetization

MCT8316Z family of devices has smart rectification features (active demagnetization) which decreases power losses in the device by reducing diode conduction losses. When this feature is enabled, the device automatically turns ON the corresponding MOSFET whenever it detects diode conduction. This feature can be configured with the MODE pins in hardware variants. In SPI device variants this can be configured through EN\_ASR and EN\_AAR bits. The smart rectification is classified into two categories of automatic synchronous rectification (ASR) mode and automatic asynchronous rectification (AAR) mode which are described in sections below.

#### Note

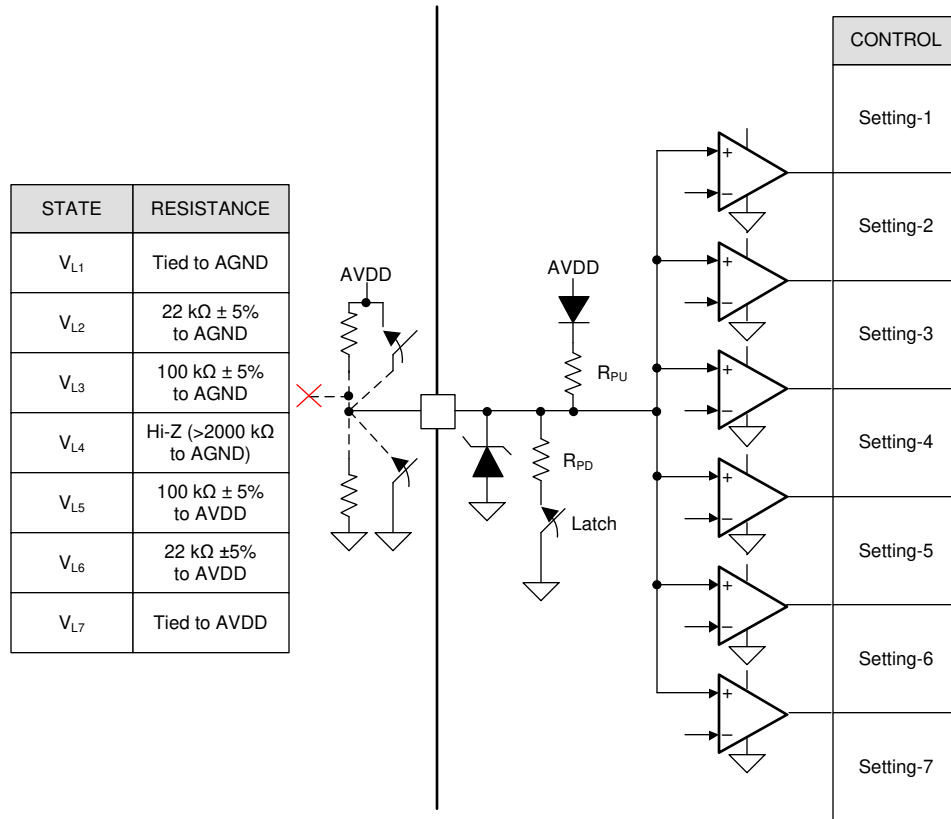
In SPI device variants both bits, EN\_ASR and EN\_AAR needs to set to 1 to enable active demagnetization.

The MCT8316Z device includes a high-side (AD\_HS) and low-side (AD\_LS) comparator which detects the negative flow of current in the device on each half-bridge. The AD\_HS comparator compares the sense-FET output with the supply voltage (VM) threshold, whereas the AD\_LS comparator compares with the ground (0-V) threshold. Depending upon the flow of current from OUTx to VM or PGND to OUTx, the AD\_HS or the AD\_LS comparator trips. This comparator provides a reference point for the operation of active demagnetization feature.



图 8-29. Active Demagnetization Operation

表 8-7 shows the configuration of ASR and AAR mode in the MCT8316Z device.

表 8-7. PWM\_MODE Configuration

MODE Type	MODE Pin (Hardware Variant)	ASR and AAR configuration	Hall Configuration	Modulation	ASR and AAR Mode
Mode 1	Connected to AGND	EN_ASR = 0, EN_AAR = 0	Analog Hall Input	Asynchronous	ASR and AAR Disabled
Mode 2	Connected to AGND with R <sub>MODE1</sub>	EN_ASR = 0, EN_AAR = 0	Digital Hall Input	Asynchronous	ASR and AAR Disabled
Mode 3	Connected to AGND with R <sub>MODE2</sub>	EN_ASR = 0, EN_AAR = 0	Analog Hall Input	Synchronous	ASR and AAR Disabled
Mode 4	Hi-Z	EN_ASR = 0, EN_AAR = 0	Digital Hall Input	Synchronous	ASR and AAR Disabled
Mode 5	Connected to AVDD with R <sub>MODE2</sub>	EN_ASR = 1, EN_AAR = 1	Analog Hall Input	Synchronous	ASR and AAR Enabled

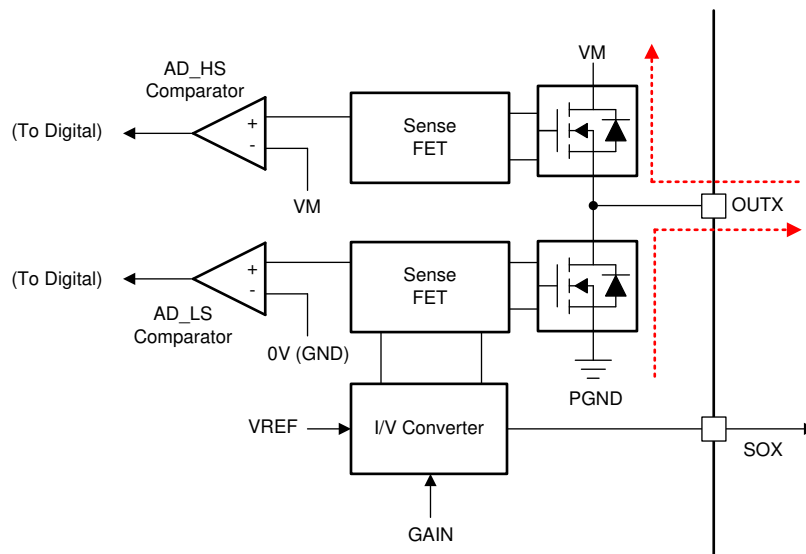
**表 8-7. PWM\_MODE Configuration (continued)**

MODE Type	MODE Pin (Hardware Variant)	ASR and AAR configuration	Hall Configuration	Modulation	ASR and AAR Mode
Mode 6	Connected to AVDD with R <sub>MODE1</sub>	EN_ASR = 1, EN_AAR = 1	Digital Hall Input	Synchronous	ASR and AAR Enabled
Mode 7	Connected to AVDD				

### 8.3.11.1 Automatic Synchronous Rectification Mode (ASR Mode)

The automatic synchronous rectification (ASR) mode is divided into two categories of ASR during commutation and ASR during PWM mode.

#### 8.3.11.1.1 Automatic Synchronous Rectification in Commutation

图 8-30 shows the operation of active demagnetization during the BLDC motor commutation. As shown in 图 8-30 (a), the current is flowing from HA to LC in one commutation state. During the commutation changeover as shown in 图 8-30 (b), the HC switch is turned on, whereas the commutation current (due to motor inductance) in OUTA flows through the body diode of LA. This incorporates a higher diode loss depending on the commutation current. This commutation loss is reduced by turning on the LA for the commutation time as shown in 图 8-30 (c).

Similarly the operation of high-side FET is realized in 图 8-30 (d), (e) and (f).

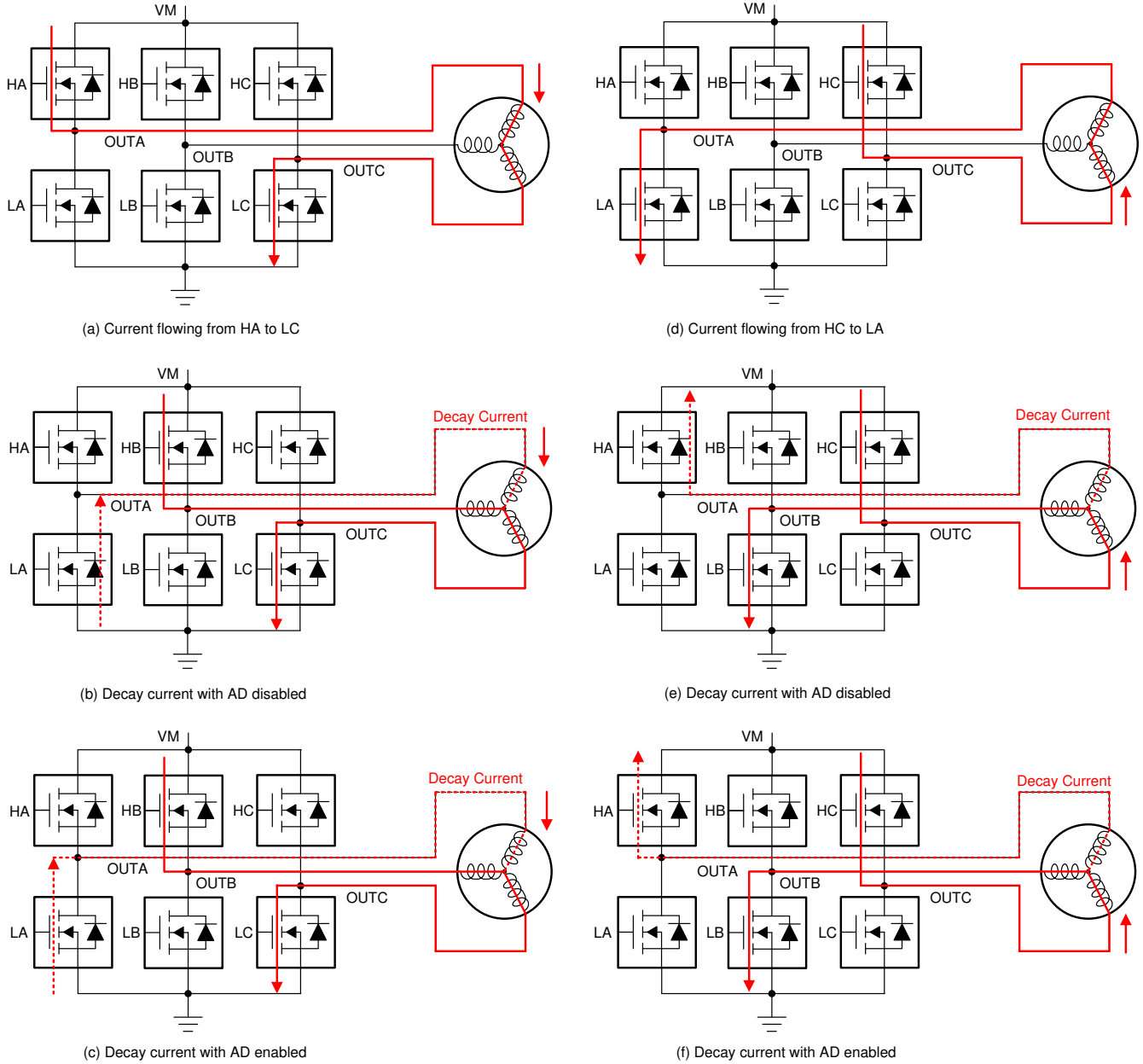

**图 8-30. ASR in BLDC Motor Commutation**



### 8.3.11.1.2 Automatic Synchronous Rectification in PWM Mode

Figure 8-32 shows the operation of ASR in PWM mode. As shown in this figure, a PWM is applied only on the high-side FET, whereas the low-side FET is always off. During the PWM off time, current decays from the low-side FET which results in higher power losses. Therefore, this mode supports turning on the low-side FET during the low-side diode conduction.

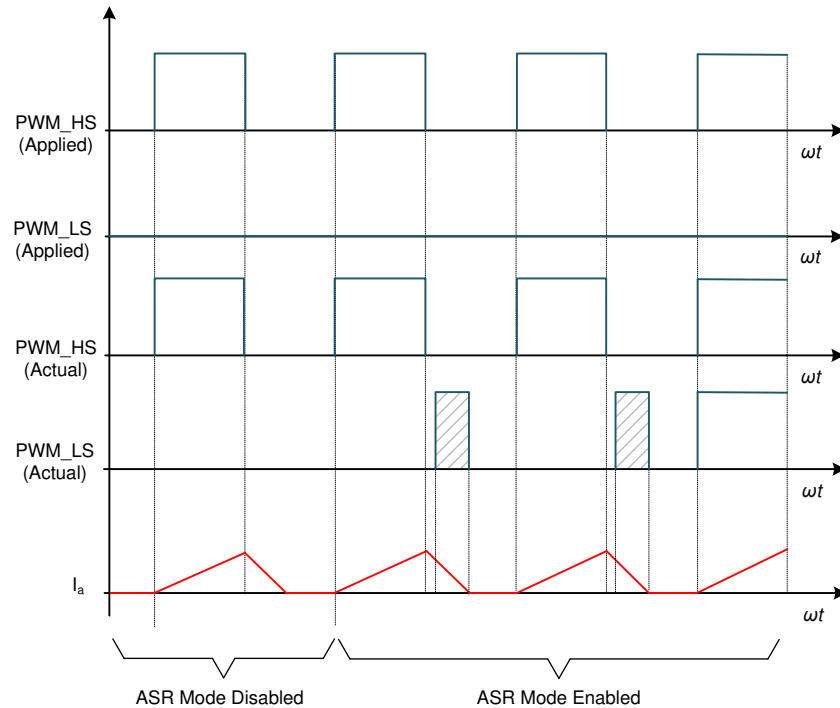

Figure 8-32. ASR in PWM Mode

### 8.3.11.2 Automatic Asynchronous Rectification Mode (AAR Mode)

图 8-33 shows the operation of AAR in PWM mode. As shown in this figure, a PWM is applied in a synchronous rectification to the high-side and low-side FETs. During the low-side FET conduction, for lower inductance motors, the current can decay to zero and becomes negative since low side FET is in on-state. This creates a negative torque on the BLDC motor operation. When AAR mode is enabled, the current during the decay is monitored and the low-side FET is turned off as soon as the current reaches near to zero. This saves the negative current building in the BLDC motor which results in better noise performance and better thermal management.



图 8-33. AAR in PWM Mode

### 8.3.12 Cycle-by-Cycle Current Limit

The current-limit circuit activates if the current flowing through the low-side MOSFET exceeds the  $I_{LIMIT}$  current. This feature restricts motor current to less than the  $I_{LIMIT}$ .

The current-limit circuitry utilizes the current sense amplifier output of the three phases compared with the voltage at ILIM pin. 图 8-34 shows the implementation of current limit circuitry. As shown in this figure, the output of current sense amplifiers is combined with star connected resistive network. This measured voltage  $V_{MEAS}$  is compared with the external reference voltage e  $V_{ILIM}$  pin to realize the current limit implementation. The relation between current sensed on OUTX pin and  $V_{MEAS}$  threshold is given as:

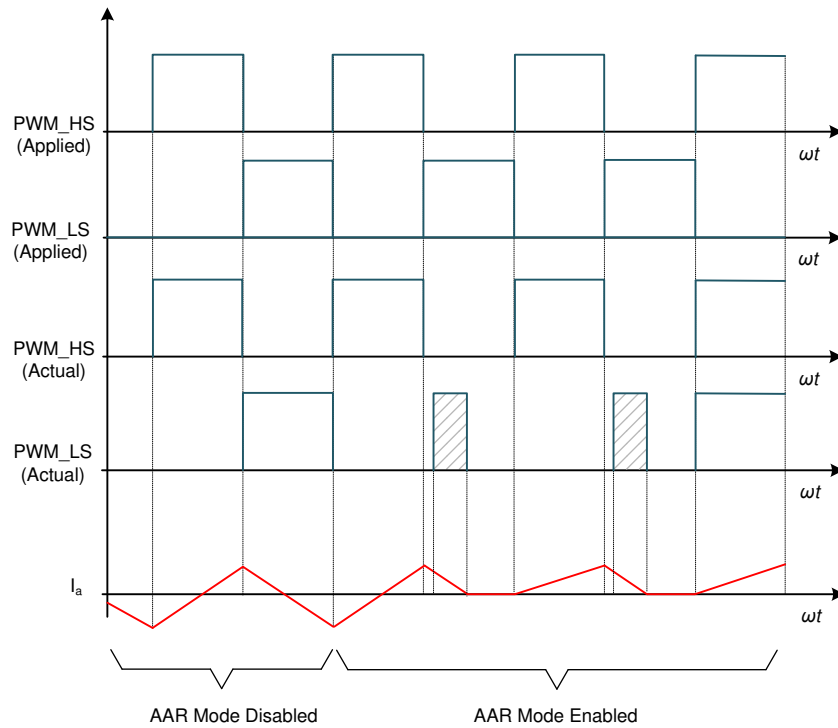
$$V_{MEAS} = \left( \frac{V_{AVDD}}{2} \right) - ((I_{OUTA} + I_{OUTB} + I_{OUTC}) \times GAIN/3) \quad (4)$$

where

- AVDD is 3.3-V LDO output
- OUTX is current flowing into the low-side MOSFET
- GAIN is the CSA\_GAIN setting

The  $I_{LIMIT}$  threshold can be adjusted by configuring ILIM pin between  $AVDD/2$  to  $(AVDD/2 - 0.4)$  V.  $AVDD/2$  is minimum value and when it is applied on ILIM pin cycle by cycle current limit is disabled, whereas maximum threshold of 8A can be configured by applying  $(AVDD/2 - 0.4)$  V on ILIM pin.



图 8-34. Current Limit Implementation

When then the current limit activates, the high-side FET is disabled until the beginning of the next PWM cycle as shown in 图 8-35. The low-side FETs can operate in brake mode or high-Z mode by configuring the ILIM\_RECIR bit in the SPI device variant.

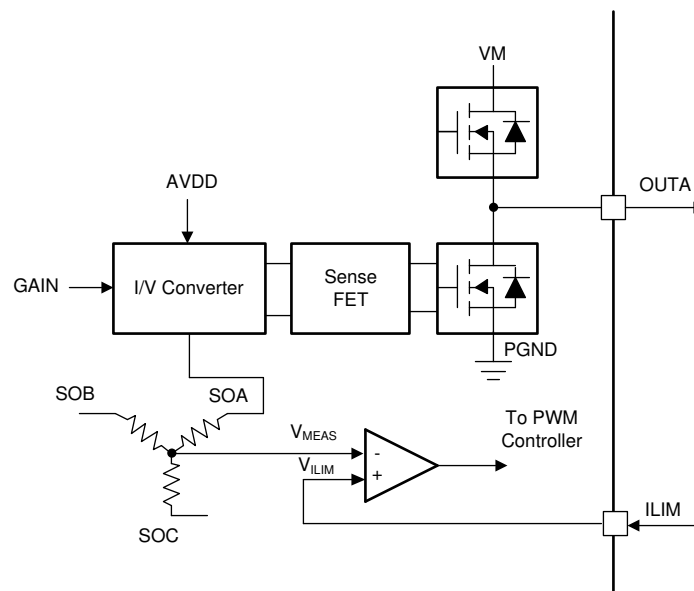

图 8-35. Cycle-by-Cycle Current-Limit Operation

In the MCT8316Z device, when the current limit activates in synchronous rectification mode, the current recirculates through the low-side FETs while the high-side FETs are disabled as shown in [图 8-36](#)

Moreover, when the current limit activates in asynchronous rectification mode, the current recirculates through the body diodes of the low-side FETs while the high-side FETs are disabled as shown in [图 8-37](#)

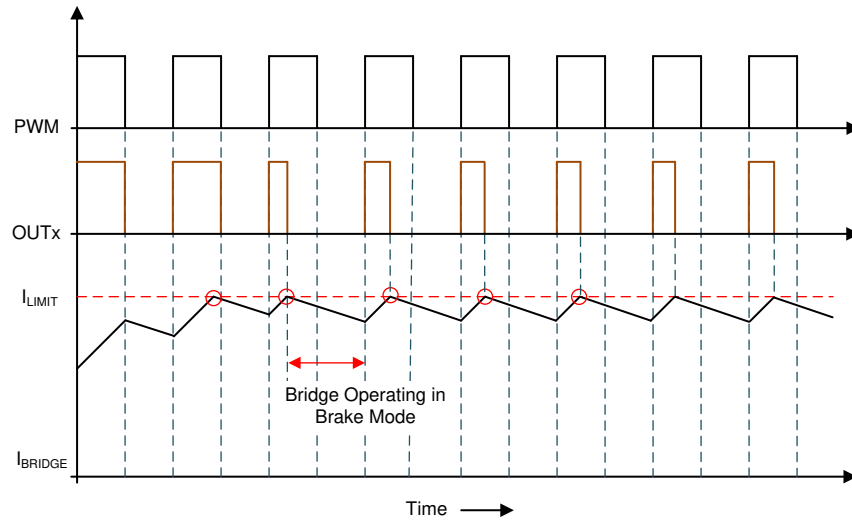
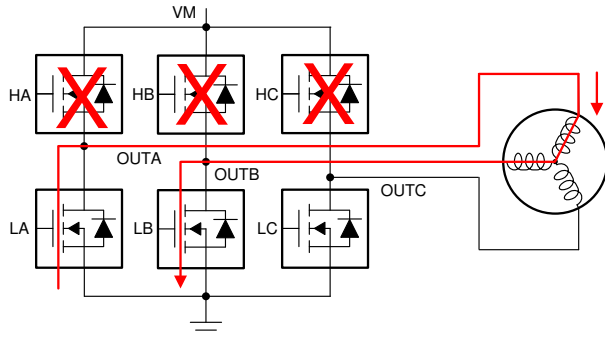

**图 8-36. Brake State**

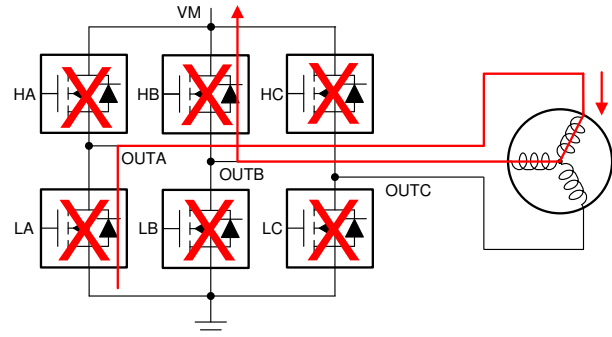

**图 8-37. Coast State**

---

#### Note

The current-limit circuit is ignored immediately after the PWM signal goes active for a short blanking time to prevent false trips of the current-limit circuit.

---

#### Note

During the brake operation, a high-current can flow through the low-side FETs which can eventually trigger the over current protection circuit. This allows the body-diode of the high-side FET to conduct and pump brake energy to the VM supply rail.

---

### 8.3.12.1 Cycle by Cycle Current Limit with 100% Duty Cycle Input

In case of 100% duty cycle applied on PWM input, there is no edge available to turn high-side FET back on. To overcome this problem, MCT8316Z has built in internal PWM clock which is used to turn high-side FET back on once it is disabled after exceeding  $I_{LIMIT}$  threshold. In SPI variant MCT8316ZR, this internal PWM clock can be configured to either 20 kHz or 40 kHz through PWM\_100\_DUTY\_SEL. In H/W variant MCT8316ZT PWM internal clock is set to 20 kHz. 图 8-38 shows operation with 100 % duty cycle.



图 8-38. Cycle-by-Cycle Current-Limit Operation with 100% PWM Duty Cycle

### 8.3.13 Hall Comparators (Analog Hall Inputs)

Three comparators are provided to process the raw signals from the Hall-effect sensors to commutate the motor. The Hall comparators sense the zero crossings of the differential inputs and pass the information to digital logic. The Hall comparators have hysteresis, and their detect threshold is centered at 0. The hysteresis is defined as shown in 图 8-39.

In addition to the hysteresis, the Hall inputs are deglitched with a circuit that ignores any extra Hall transitions for a period of  $t_{HDEG}$  after sensing a valid transition. Ignoring these transitions for the  $t_{HDEG}$  time prevents PWM noise from being coupled into the Hall inputs, which can result in erroneous commutation.

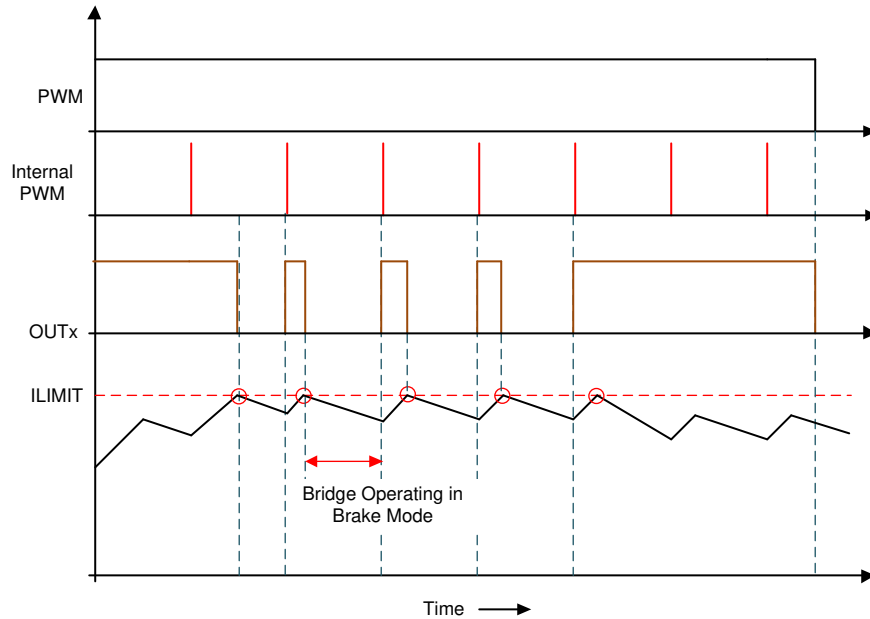
If excessive noise is still coupled into the Hall comparator inputs, adding capacitors between the positive and negative inputs of the Hall comparators may be required. The ESD protection circuitry on the Hall inputs implements a diode to the AVDD pin. Because of this diode, the voltage on the Hall inputs should not exceed the AVDD voltage.

Because the AVDD pin is disabled in sleep mode (nSLEEP inactive), the Hall inputs should not be driven by external voltages in sleep mode. If the Hall sensors are powered externally, the supply to the Hall sensors should be disabled if the MCT8316Z device is put into sleep mode. In addition, the Hall sensors' power supply should be powered up after enabling the motor otherwise an invalid Hall state may cause a delay in motor operation.



图 8-39. Hall Comparators Operation

### 8.3.14 Advance Angle

The MCT8316Z includes device an advance angle feature to advance the commutation by a specified electrical angle based on the voltage on the ADVANCE pin (in H/W device variant) or the ADVANCE bits (in SPI device variant). 图 8-40 shows the operation of advance angle feature.

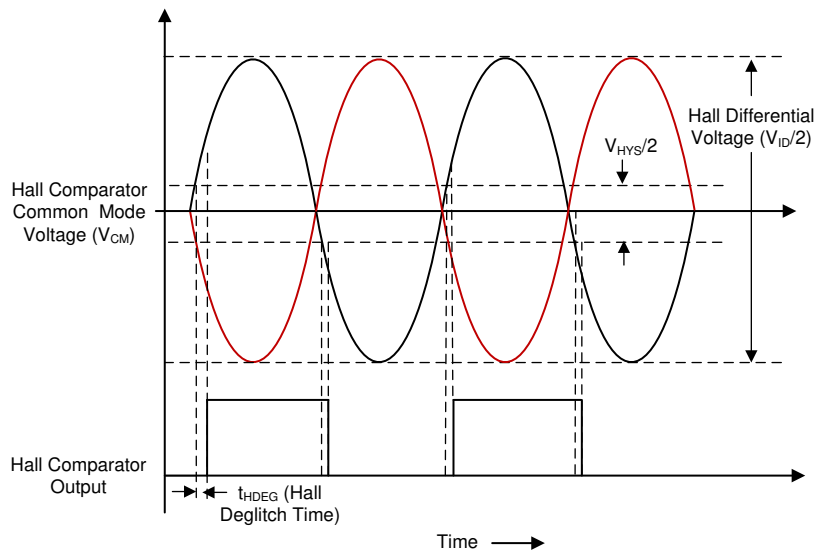

图 8-40. Advance Angle

### 8.3.15 FGOUT Signal

The MCT8316Z device also has an open-drain FGOUT signal that can be used for closed-loop speed control of a BLDC motor. This signal includes the information of all three Hall-elements inputs as shown in 节 8.3.15. In the MCT8316ZR (SPI variant), FGOUT can be configured to be a different division factor of Hall signals as shown in 节 8.3.15. In the MCT8316ZT (Hardware variant), the default mode is FGOUT = 00b.

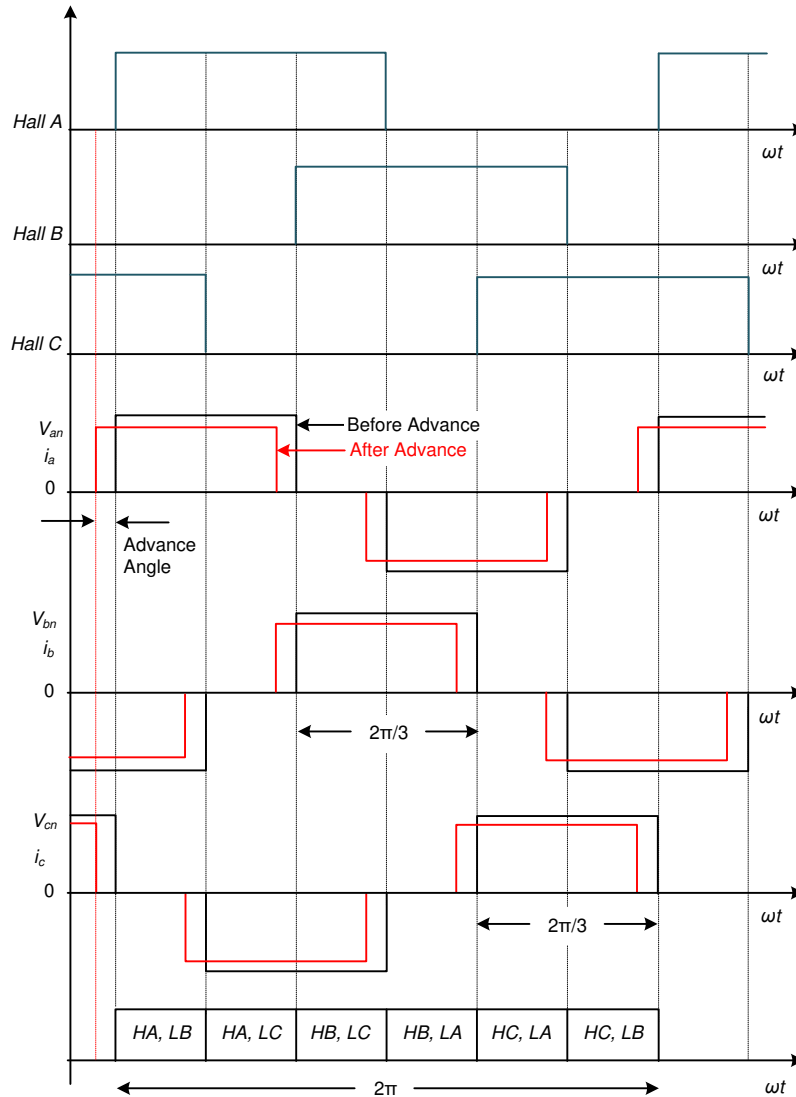

图 8-41. FGOUT Signal

### 8.3.16 Protections

The MCT8316Z family of devices is protected against VM undervoltage, charge pump undervoltage, and overcurrent events. 表 8-8 summarizes various faults details.

**表 8-8. Fault Action and Response (SPI Devices)**

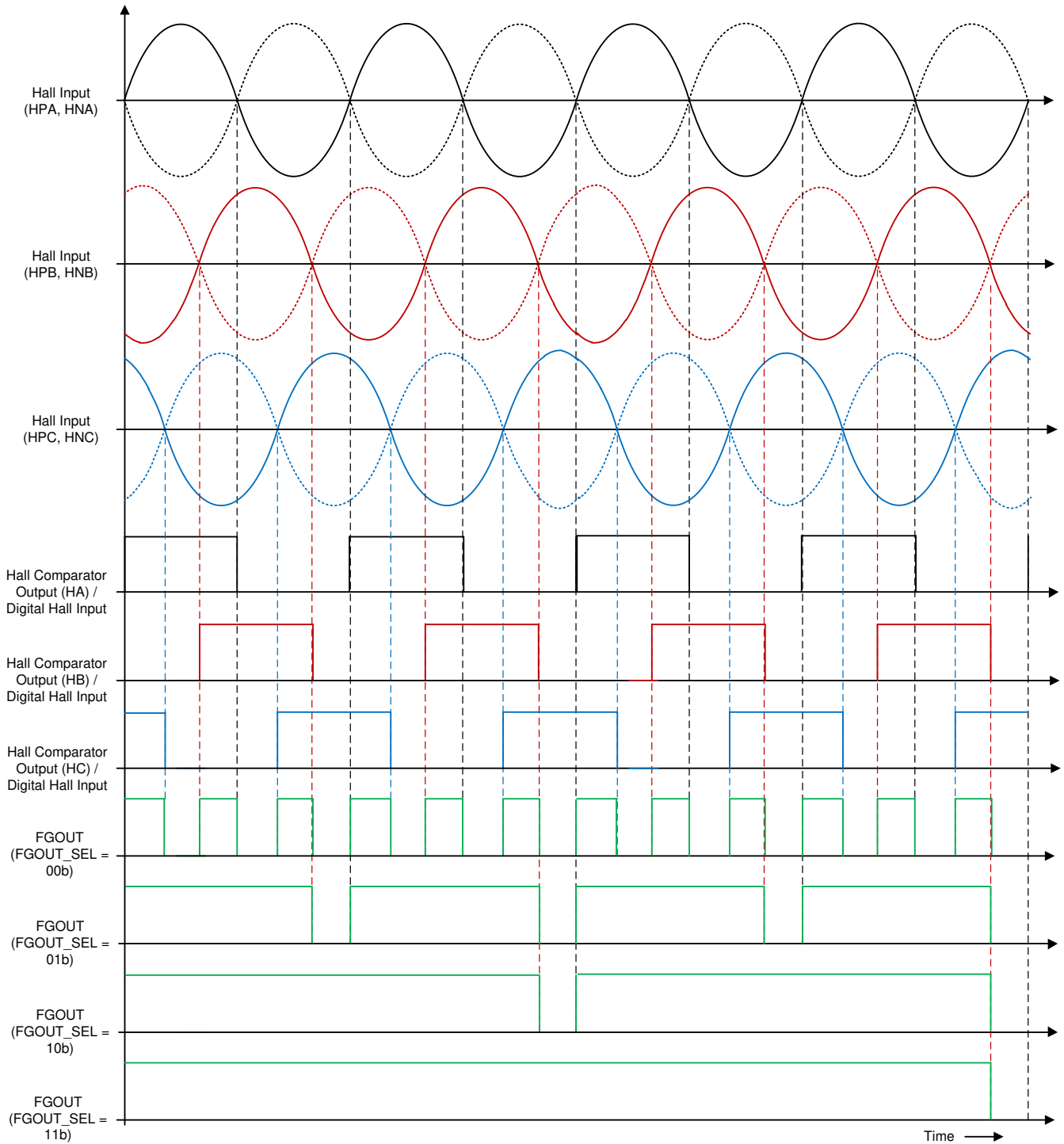
FAULT	CONDITION	CONFIGURATION	REPORT	H-BRIDGE	LOGIC	RECOVERY
VM undervoltage (NPOR)	$V_{VM} < V_{UVLO}$	—	—	Hi-Z	Disabled	Automatic: $V_{VM} > V_{UVLO\_R}$ CLR_FLT, nSLEEP Reset Pulse (NPOR bit)
AVDD undervoltage (NPOR)	$V_{AVDD} < V_{AVDD\_UV}$	—	—	Hi-Z	Disabled	Automatic: $V_{AVDD} > V_{AVDD\_UV\_R}$ CLR_FLT, nSLEEP Reset Pulse (NPOR bit)
Buck undervoltage (BUCK_UV)	$V_{FB\_BK} < V_{BK\_UV}$	—	nFAULT	Active	Active	Automatic: $V_{FB\_BK} > V_{BUCK\_UV\_R}$ CLR_FLT, nSLEEP Reset Pulse (BUCK_UV bit)
Charge pump undervoltage (VCP_UV)	$V_{CP} < V_{CPLV}$	—	nFAULT	Hi-Z	Active	Automatic: $V_{VCP} > V_{CPLV}$ CLR_FLT, nSLEEP Reset Pulse (VCP_UV bit)
OverVoltage Protection (OVP)	$V_{VM} > V_{OVP}$	OVP_EN = 0b	None	Active	Active	No action (OVP Disabled)
		OVP_EN = 1b	FAULT	Hi-Z	Active	Automatic: $V_{VM} < V_{OVP}$ CLR_FLT, nSLEEP Reset Pulse (OVP bit)
Overcurrent Protection (OCP)	$I_{PHASE} > I_{OCP}$	OCP_MODE = 00b	nFAULT	Hi-Z	Active	Latched: CLR_FLT, nSLEEP Reset Pulse (OCP bits)
		OCP_MODE = 01b	nFAULT	Hi-Z	Active	Retry: $t_{RETRY}$
		OCP_MODE = 10b	nFAULT	Active	Active	Automatic: CLR_FLT, nSLEEP Reset Pulse (OCP bits)
		OCP_MODE = 11b	None	Active	Active	No action
Buck Overcurrent Protection (BUCK_OCP)	$I_{BK} > I_{BK\_OC}$	—	nFAULT	Active	Active	Retry: $t_{RETRY}$
SPI Error (SPI_FLT)	SCLK fault and ADDR fault	SPI_FLT_REP = 0b	nFAULT	Active	Active	Automatic: CLR_FLT, nSLEEP Reset Pulse (SPI_FLT bit)
		SPI_FLT_REP = 1b	None	Active	Active	No action
OTP Error (OTP_ERR)	OTP reading is erroneous	—	nFAULT	Hi-Z	Active	Latched: Power Cycle, nSLEEP Reset Pulse
Motor Lock (MTR_LOCK)	No Hall Signals > $t_{MTR\_LOCK\_TDET}$	MTR_LOCK_MODE = 00b	nFAULT	Hi-Z	Active	Latched: CLR_FLT, nSLEEP Pulse (MTR_LOCK bit)
		MTR_LOCK_MODE = 01b	nFAULT	Hi-Z	Active	Retry: $t_{MTR\_LOCK\_RETRY}$
		MTR_LOCK_MODE = 10b	nFAULT	Active	Active	Automatic: CLR_FLT, nSLEEP Reset Pulse (OCP bits)
		MTR_LOCK_MODE = 11b	None	Active	Active	No action
Thermal warning (OTW)	$T_J > T_{OTW}$	OTW_REP = 0b	None	Active	Active	No action
		OTW_REP = 1b	nFAULT	Active	Active	Automatic: $T_J < T_{OTW} - T_{HYS}$ CLR_FLT, nSLEEP Pulse (OTW bit)
Thermal shutdown (OTSD)	$T_J > T_{OTSD}$	—	nFAULT	Hi-Z	Active	Automatic: $T_J < T_{OTSD} - T_{HYS}$ CLR_FLT, nSLEEP Pulse (OTS bit)

### 8.3.16.1 VM Supply Undervoltage Lockout (NPOR)

If at any time the input supply voltage on the VM pin falls lower than the  $V_{UVLO}$  threshold (VM UVLO falling threshold), all of the integrated FETs, driver charge-pump and digital logic controller are disabled as shown in [Figure 8-42](#). Normal operation resumes (driver operation) when the VM undervoltage condition is removed. The NPOR bit is reset and latched low in the IC status (IC\_STAT) register once the device presumes VM. The NPOR bit remains in reset condition until cleared through the CLR\_FLT bit or an nSLEEP pin reset pulse ( $t_{RST}$ ).



图 8-42. VM Supply Undervoltage Lockout

### 8.3.16.2 AVDD Undervoltage Lockout (AVDD\_UV)

If at any time the voltage on AVDD pin falls lower than the  $V_{AVDD\_UV}$  threshold, all of the integrated FETs, driver charge-pump and digital logic controller are disabled. Normal operation resumes (driver operation) when the AVDD undervoltage condition is removed. The NPOR bit is reset and latched low in the IC status (IC\_STAT) register once the device presumes VM. The NPOR bit remains in reset condition until cleared through the CLR\_FLT bit or an nSLEEP pin reset pulse ( $t_{RST}$ ).

### 8.3.16.3 BUCK Undervoltage Lockout (BUCK\_UV)

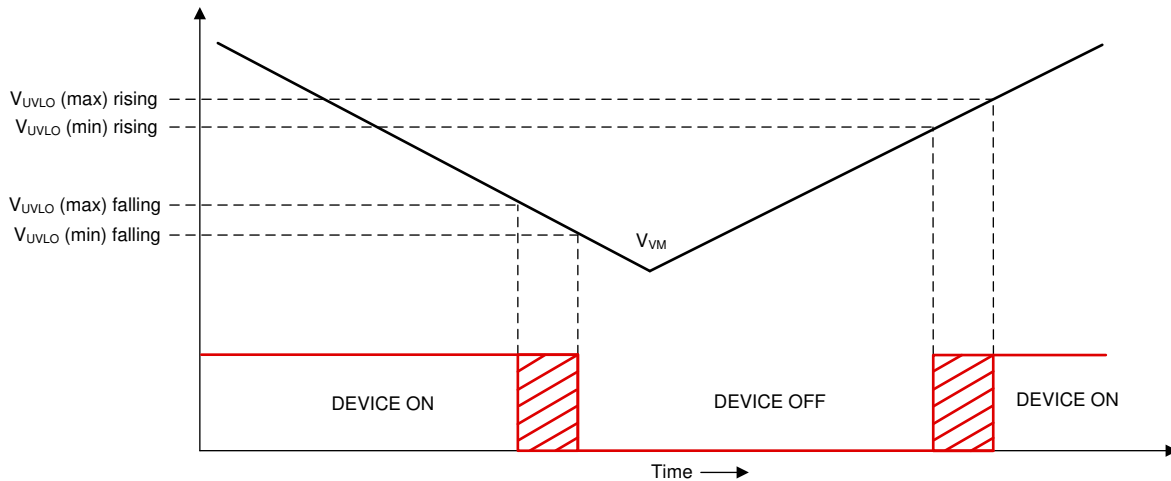
If at any time the voltage on VFB\_BK pin falls lower than the  $V_{BK\_UV}$  threshold, the integrated FETs of the buck regulator are disabled while the driver FETs, charge pump, and digital logic control continue to operate normally. The nFAULT pin is driven low in the event of a buck undervoltage fault, and the BK\_FLT bit in IC\_STAT register is set in SPI devices. The FAULT and BUCK\_UV bits are also latched high in the registers on SPI devices. Normal operation starts again (buck regulator operation and the nFAULT pin is released) when the BUCK undervoltage condition clears. The BK\_FLT and BUCK\_UV bits stay set until cleared through the CLR\_FLT bit or an nSLEEP pin reset pulse ( $t_{RST}$ ).

### 8.3.16.4 VCP Charge Pump Undervoltage Lockout (CPUV)

If at any time the voltage on the VCP pin (charge pump) falls lower than the  $V_{CPUV}$  threshold voltage of the charge pump, all of the integrated FETs are disabled and the nFAULT pin is driven low. The FAULT and VCP\_UV bits are also latched high in the registers on SPI devices. Normal operation starts again (driver operation and the nFAULT pin is released) when the VCP undervoltage condition clears. The CPUV bit stays set until cleared through the CLR\_FLT bit or an nSLEEP pin reset pulse ( $t_{RST}$ ). The CPUV protection is always enabled in both hardware and SPI device variants.

### 8.3.16.5 Overvoltage Protections (OV)

If at any time input supply voltage on the VM pins rises higher lower than the  $V_{OVP}$  threshold voltage, all of the integrated FETs are disabled and the nFAULT pin is driven low. The FAULT and OVP bits are also latched high in the registers on SPI devices. Normal operation starts again (driver operation and the nFAULT pin is released) when the OVP condition clears. The OVP bit stays set until cleared through the CLR\_FLT bit or an nSLEEP pin

reset pulse ( $t_{RST}$ ). Setting the OVP\_EN bit high on the SPI devices enables this protection feature. On hardware interface devices, the OVP protection is always enabled and set to a 34-V threshold.

The OVP threshold is also programmable on the SPI device variant. The OVP threshold can be set to 20-V or 32-V based on the OVP\_SEL bit.



图 8-43. Over Voltage Protection

### 8.3.16.6 Overcurrent Protection (OCP)

A MOSFET overcurrent event is sensed by monitoring the current flowing through FETs. If the current across a FET exceeds the  $I_{OCP}$  threshold for longer than the  $t_{OCP}$  deglitch time, an OCP event is recognized and action is done according to the OCP\_MODE bit. On hardware interface devices, the  $I_{OCP}$  threshold is fixed at 16-A threshold, the  $t_{OCP\_DEG}$  is fixed at 0.6- $\mu$ s, and the OCP\_MODE bit is configured for latched shutdown. On SPI devices, the  $I_{OCP}$  threshold is set through the OCP\_LVL SPI register, the  $t_{OCP\_DEG}$  is set through the OCP\_DEG SPI register, and the OCP\_MODE bit can operate in four different modes: OCP latched shutdown, OCP automatic retry, OCP report only, and OCP disabled.

#### 8.3.16.6.1 OCP Latched Shutdown (OCP\_MODE = 00b)

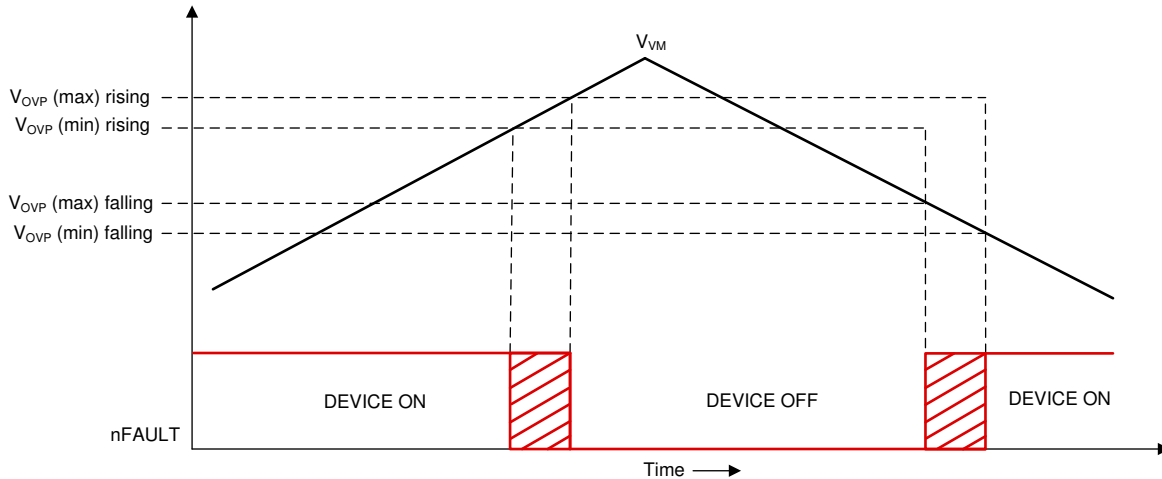
After a OCP event in this mode, all MOSFETs are disabled and the nFAULT pin is driven low. The FAULT, OCP, and corresponding FET's OCP bits are latched high in the SPI registers. Normal operation starts again (driver operation and the nFAULT pin is released) when the OCP condition clears and a clear faults command is issued either through the CLR\_FLT bit or an nSLEEP reset pulse ( $t_{RST}$ ).



图 8-44. Overcurrent Protection - Latched Shutdown Mode

#### 8.3.16.6.2 OCP Automatic Retry (OCP\_MODE = 01b)

After a OCP event in this mode, all the FETs are disabled and the nFAULT pin is driven low. The FAULT, OCP, and corresponding FET's OCP bits are latched high in the SPI registers. Normal operation starts again automatically (driver operation and the nFAULT pin is released) after the  $t_{RETRY}$  time elapses. After the  $t_{RETRY}$  time elapses, the FAULT, OCP, and corresponding FET's OCP bits stay latched until a clear faults command is issued either through the CLR\_FLT bit or an nSLEEP reset pulse ( $t_{RST}$ ).

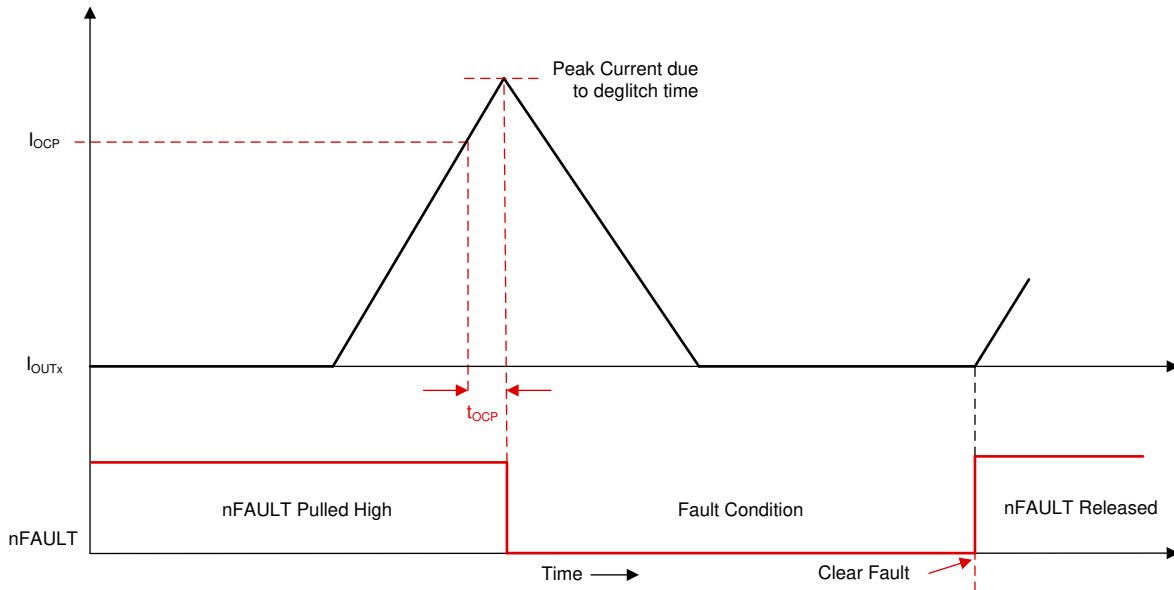

图 8-45. Overcurrent Protection - Automatic Retry Mode

#### 8.3.16.6.3 OCP Report Only (OCP\_MODE = 10b)

No protective action occurs after a OCP event in this mode. The overcurrent event is reported by driving the nFAULT pin low and latching the FAULT, OCP, and corresponding FET's OCP bits high in the SPI registers. The MCT8316Z continues to operate as usual. The external controller manages the overcurrent condition by acting

appropriately. The reporting clears (nFAULT pin is released) when the OCP condition clears and a clear faults command is issued either through the CLR\_FLT bit or an nSLEEP reset pulse ( $t_{RST}$ ).

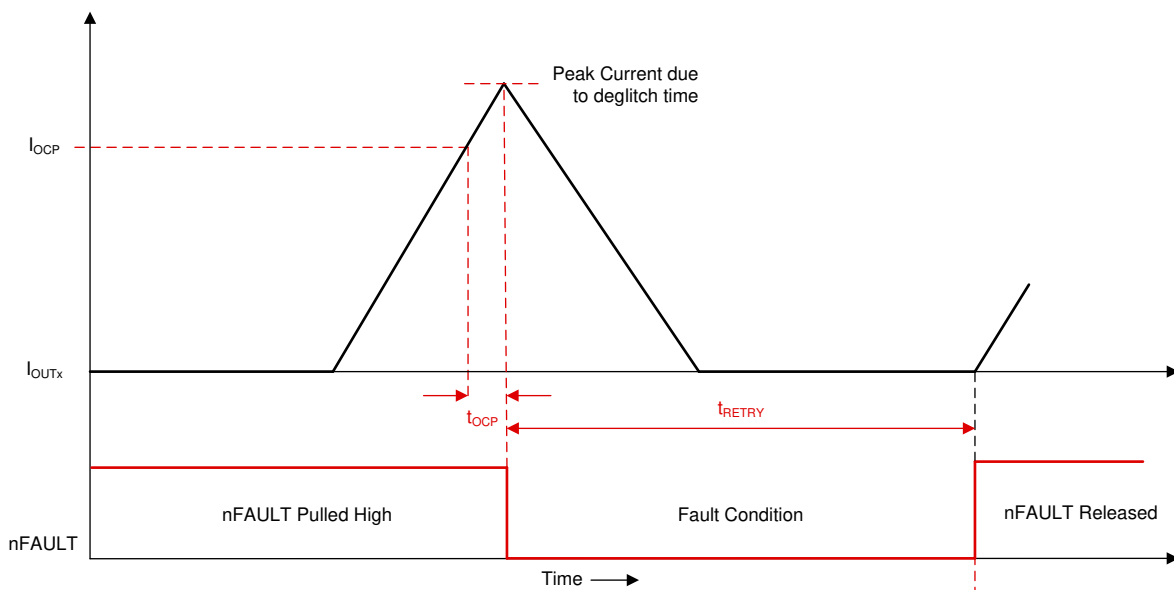
#### 8.3.16.6.4 OCP Disabled (OCP\_MODE = 11b)

No action occurs after a OCP event in this mode.

#### 8.3.16.7 Buck Overcurrent Protection

A buck overcurrent event is sensed by monitoring the current flowing through buck regulator's FETs. If the current across the buck regulator FET exceeds the  $I_{BK\_OCP}$  threshold for longer than the  $t_{BK\_OCP}$  deglitch time, an OCP event is recognized. The buck OCP mode is configured in automatic retry setting. In this setting, after a buck OCP event is detected, all the buck regulator's FETs are disabled and the nFAULT pin is driven low. The FAULT, BK\_FLT, and BUCK\_OCP bits are latched high in the SPI registers. Normal operation starts again automatically (driver operation and the nFAULT pin is released) after the  $t_{BK\_RETRY}$  time elapses. The FAULT, BK\_FLT, and BUCK\_OCP bits stay latched until the  $t_{RETRY}$  period expires.

#### 8.3.16.8 Motor Lock (MTR\_LOCK)

During motor is in lock condition the hall signals will be not available, so a Motor Lock event is sensed by monitoring the hall signals. If the hall signals are not present for longer than the  $t_{MTR\_LOCK}$ , a MTR\_LCK event is recognized and action is done according to the MTR\_LOCK\_MODE bits. On hardware interface devices, the  $t_{MTR\_LOCK}$  threshold is set to 1000-ms, and the MTR\_LOCK\_MODE bit is configured for latched shutdown. On SPI devices, the  $t_{MTR\_LOCK}$  threshold is set through the MTR\_LOCK\_TDET register and the MTR\_LOCK\_MODE bit can operate in four different modes: MTR\_LOCK latched shutdown, MTR\_LOCK automatic retry, MTR\_LOCK report only, and MTR\_LOCK disabled.

##### 8.3.16.8.1 MTR\_LOCK Latched Shutdown (MTR\_LOCK\_MODE = 00b)

After a motor lock event in this mode, all FETs are disabled and the nFAULT pin is driven low. The FAULT and MTR\_LOCK bits are latched high in the SPI registers. Normal operation starts again (driver operation and the nFAULT pin is released) when a clear faults command is issued either through the CLR\_FLT bit or an nSLEEP reset pulse ( $t_{RST}$ ).

##### 8.3.16.8.2 MTR\_LOCK Automatic Retry (MTR\_LOCK\_MODE = 01b)

After a motor lock event in this mode, all the external MOSFETs are disabled and the nFAULT pin is driven low. The FAULT and MTR\_LOCK bits are latched high in the SPI registers. Normal operation starts again automatically (driver operation and the nFAULT pin is released) after the  $t_{MTR\_LOCK\_RETRY}$  time elapses. The FAULT and MTR\_LOCK bits stay latched until the  $t_{MTR\_LOCK\_RETRY}$  period expires.

##### 8.3.16.8.3 MTR\_LOCK Report Only (MTR\_LOCK\_MODE= 10b)

No protective action occurs after a MTR\_LOCK event in this mode. The motor lock event is reported by driving the nFAULT pin low and latching the FAULT and MTR\_LOCK bits high in the SPI registers. The MCT8316Z continues to operate as usual. The external controller manages the motor lock condition by acting appropriately. The reporting clears (nFAULT pin is released) when a clear faults command is issued either through the CLR\_FLT bit or an nSLEEP reset pulse ( $t_{RST}$ ).

##### 8.3.16.8.4 MTR\_LOCK Disabled (MTR\_LOCK\_MODE = 11b)

No action occurs after a MTR\_LOCK event in this mode.

##### 8.3.16.8.5

---

#### Note

The motor lock detection scheme requires the PWM off-time ( $t_{PWM\_OFF}$ ) to be lower than the motor lock detection time ( $t_{MTR\_LOCK}$ )

---

#### 8.3.16.9 Thermal Warning (OTW)

If the die temperature exceeds the trip point of the thermal warning ( $T_{OTW}$ ), the OT bit in the IC status (IC\_STAT) register and OTW bit in the status register is set. The reporting of OTW on the nFAULT pin can be enabled by

setting the over-temperature warning reporting (OTW\_REP) bit in the configuration control register. The device performs no additional action and continues to function. In this case, the nFAULT pin releases when the die temperature decreases below the hysteresis point of the thermal warning ( $T_{OTW\_HYS}$ ). The OTW bit remains set until cleared through the CLR\_FLT bit or an nSLEEP reset pulse ( $t_{RST}$ ) and the die temperature is lower than thermal warning trip ( $T_{OTW}$ ).

---

#### Note

Over temperature warning is not reported on nFAULT pin by default.

---

#### 8.3.16.10 Thermal Shutdown (OTS)

If the die temperature exceeds the trip point of the thermal shutdown limit ( $T_{OTS}$ ), all the FETs are disabled, the charge pump is shut down, and the nFAULT pin is driven low. In addition, the FAULT and OT bit in the IC status (IC\_STAT) register and OTS bit in the status register is set. Normal operation starts again (driver operation and the nFAULT pin is released) when the overtemperature condition clears. The OTS bit stays latched high indicating that a thermal event occurred until a clear fault command is issued either through the CLR\_FLT bit or an nSLEEP reset pulse ( $t_{RST}$ ). This protection feature cannot be disabled.

## 8.4 Device Functional Modes

### 8.4.1 Functional Modes

#### 8.4.1.1 Sleep Mode

The nSLEEP pin manages the state of the MCT8316Z family of devices. When the nSLEEP pin is low, the device goes to a low-power sleep mode. In sleep mode, all FETs are disabled, sense amplifiers are disabled, buck regulator (if present) is disabled, the charge pump is disabled, the AVDD regulator is disabled, and the SPI bus is disabled. The  $t_{\text{SLEEP}}$  time must elapse after a falling edge on the nSLEEP pin before the device goes to sleep mode. The device comes out of sleep mode automatically if the nSLEEP pin is pulled high. The  $t_{\text{WAKE}}$  time must elapse before the device is ready for inputs.

In sleep mode and when  $V_{\text{VM}} < V_{\text{UVLO}}$ , all MOSFETs are disabled.

---

#### Note

During power up and power down of the device through the nSLEEP pin, the nFAULT pin is held low as the internal regulators are enabled or disabled. After the regulators have enabled or disabled, the nFAULT pin is automatically released. The duration that the nFAULT pin is low does not exceed the  $t_{\text{SLEEP}}$  or  $t_{\text{WAKE}}$  time.

---

---

#### Note

TI recommends to connect pull up on nFAULT even if it is not used to avoid undesirable entry into internal test mode. If external supply is used to pull up nFAULT, ensure that it is pulled to  $>2.2\text{V}$  on power up or the device will enter internal test mode.

---

#### 8.4.1.2 Operating Mode

When the nSLEEP pin is high and the  $V_{\text{VM}}$  voltage is greater than the  $V_{\text{UVLO}}$  voltage, the device goes to operating mode. The  $t_{\text{WAKE}}$  time must elapse before the device is ready for inputs. In this mode the charge pump, AVDD regulator, buck regulator, and SPI bus are active.

#### 8.4.1.3 Fault Reset (CLR\_FLT or nSLEEP Reset Pulse)

In the case of device latched faults, the MCT8316Z family of devices goes to a partial shutdown state to help protect the power MOSFETs and system.

When the fault condition clears, the device can go to the operating state again by either setting the CLR\_FLT SPI bit on SPI devices or issuing a reset pulse to the nSLEEP pin on either interface variant. The nSLEEP reset pulse ( $t_{\text{RST}}$ ) consists of a high-to-low-to-high transition on the nSLEEP pin. The low period of the sequence should fall with the  $t_{\text{RST}}$  time window or else the device will start the complete shutdown sequence. The reset pulse has no effect on any of the regulators, device settings, or other functional blocks.

### 8.4.2 DRVOFF functionality

When DRVOFF pin is pulled high, all six MOSFETs are disabled. If nSLEEP is high when the DRVOFF pin is high, the charge pump, AVDD regulator, buck regulator, and SPI bus are active and any driver-related faults such as OCP will be inactive. DRVOFF pin independently disables MOSFETs which will stop motor commutation irrespective of status of PWM input pin.

---

#### Note

Since DRVOFF pin independently disables MOSFET, it can trigger fault condition resulting in nFAULT getting pulled low.

---

## 8.5 SPI Communication

### 8.5.1 Programming

On MCT8316Z SPI devices, an SPI bus is used to set device configurations, operating parameters, and read out diagnostic information. The SPI operates in secondary mode and connects to a controller. The SPI input data (SDI) word consists of a 16-bit word, with a 6-bit address and 8 bits of data. The SPI output consists of 16 bit word, with a 8 bits of status information (STAT register) and 8-bit register data.

A valid frame must meet the following conditions:

- The SCLK pin should be low when the nSCS pin transitions from high to low and from low to high.
- The nSCS pin should be pulled high for at least 400 ns between words.
- When the nSCS pin is pulled high, any signals at the SCLK and SDI pins are ignored and the SDO pin is placed in the Hi-Z state.
- Data is captured on the falling edge of the SCLK pin and data is propagated on the rising edge of the SCLK pin.
- The most significant bit (MSB) is shifted in and out first.
- A full 16 SCLK cycles must occur for transaction to be valid.
- If the data word sent to the SDI pin is less than or more than 16 bits, a frame error occurs and the data word is ignored.
- For a write command, the existing data in the register being written to is shifted out on the SDO pin following the 8-bit status data.

The SPI registers are reset to the default settings on power up and when the device is enters sleep mode

#### 8.5.1.1 SPI Format

The SDI input data word is 16 bits long and consists of the following format:

- 1 read or write bit, W (bit B15)
- 6 address bits, A (bits B14 through B9)
- Parity bit, P (bit B8). Parity bit is set such that the SDI input data word has even number of 1s and 0s
- 8 data bits, D (bits B7 through B0)

The SDO output data word is 16 bits long and the first 8 bits are status bits. The data word is the content of the register being accessed.

For a write command ( $W0 = 0$ ), the response word on the SDO pin is the data currently in the register being written to.

For a read command ( $W0 = 1$ ), the response word is the data currently in the register being read.



图 8-46.



图 8-47.

表 8-9. SDI Input Data Word Format

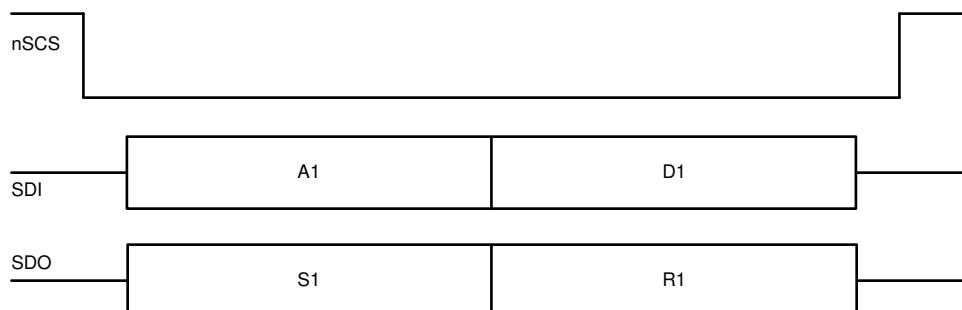
R/W	ADDRESS						Parity	DATA							
B15	B14	B13	B12	B11	B10	B9	B8	B7	B6	B5	B4	B3	B2	B1	B0
W0	A5	A4	A3	A2	A1	A0	P	D7	D6	D5	D4	D3	D2	D1	D0

表 8-10. SDO Output Data Word Format

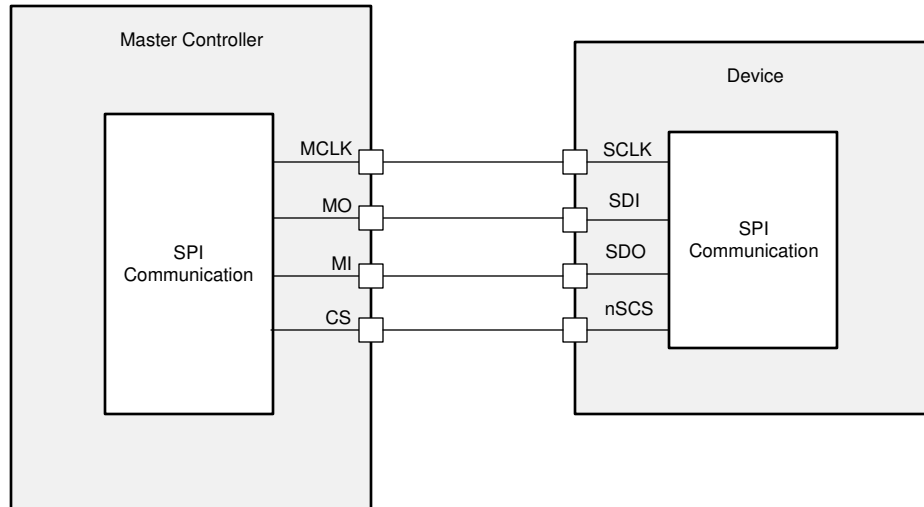
STATUS								DATA							
B15	B14	B13	B12	B11	B10	B9	B8	B7	B6	B5	B4	B3	B2	B1	B0
S7	S6	S5	S4	S3	S2	S1	S0	D7	D6	D5	D4	D3	D2	D1	D0



图 8-48. SPI Secondary Timing Diagram

### SPI Error Handling

**SPI Frame Error (SPI\_SCLK\_FLT):** If the nSCS gets deasserted before the end of 16-bit frame, SPI frame error is detected and SPI\_SCLK\_FLT bit is set in STAT2. The SPI\_SCLK\_FLT status bit is latched and can be cleared when a clear faults command is issued either through the CLR\_FLT bit or an nSLEEP reset pulse

**SPI Address Error (SPI\_ADDR\_FLT):** If an invalid address is provided in the ADDR field of the input SPI data on SDI, SPI address error is detected and SPI\_ADDR\_FLT bit in STAT2 is set. Invalid address is any address that is not defined in [Register Map](#) i.e. address not falling in the range of address 0x0 to 0xC. The SPI\_ADDR\_FLT status bit is latched and can be cleared when a clear faults command is issued either through the CLR\_FLT bit or an nSLEEP reset pulse

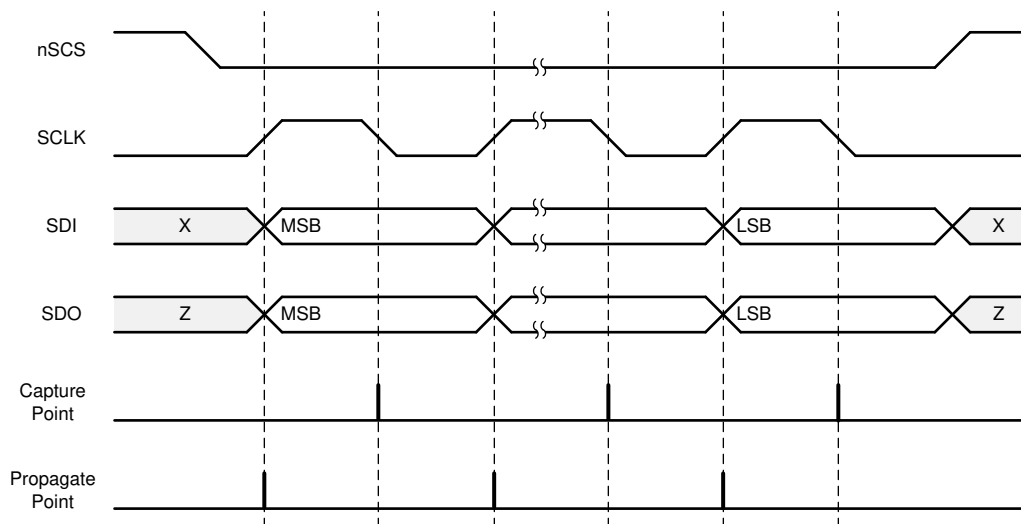
## 8.6 Register Map

### 8.6.1 STATUS Registers

[STATUS Registers](#) lists the memory-mapped registers for the STATUS registers. All register offset addresses not listed in [STATUS Registers](#) should be considered as reserved locations and the register contents should not be modified.

**表 8-11. STATUS Registers**

Offset	Acronym	Register Name	Section
0h	IC_Status_Register	IC Status Register	<a href="#">节 8.6.1.1</a>
1h	Status_Register_1	Status Register 1	<a href="#">节 8.6.1.2</a>
2h	Status_Register_2	Status Register 2	<a href="#">节 8.6.1.3</a>

Complex bit access types are encoded to fit into small table cells. [STATUS Access Type Codes](#) shows the codes that are used for access types in this section.

**表 8-12. STATUS Access Type Codes**

Access Type	Code	Description
<b>Read Type</b>		
R	R	Read
R-0	R -0	Read Returns 0s
<b>Reset or Default Value</b>		
-n		Value after reset or the default value

### 8.6.1.1 IC\_Status\_Register Register (Offset = 0h) [Reset = 00h]

IC\_Status\_Register is shown in [IC\\_Status\\_Register Register](#) and described in [IC\\_Status\\_Register Register Field Descriptions](#).

Return to the [STATUS Registers](#).

图 8-49. IC\_Status\_Register Register

7	6	5	4	3	2	1	0
MTR_LOCK	BK_FLT	SPI_FLT	OCP	NPOR	OVP	OT	FAULT
R-0h	R-0h	R-0h	R-0h	R-0h	R-0h	R-0h	R-0h

表 8-13. IC\_Status\_Register Register Field Descriptions

Bit	Field	Type	Reset	Description
7	MTR_LOCK	R	0h	Motor Lock Status Bit 0h = No motor lock is detected 1h = Motor lock is detected
6	BK_FLT	R	0h	Buck Fault Bit 0h = No buck regulator fault condition is detected 1h = Buck regulator fault condition is detected
5	SPI_FLT	R	0h	SPI Fault Bit 0h = No SPI fault condition is detected 1h = SPI Fault condition is detected
4	OCP	R	0h	Over Current Protection Status Bit 0h = No overcurrent condition is detected 1h = Overcurrent condition is detected
3	NPOR	R	0h	Supply Power On Reset Bit 0h = Power on reset condition is detected on VM 1h = No power-on-reset condition is detected on VM
2	OVP	R	0h	Supply Overvoltage Protection Status Bit 0h = No overvoltage condition is detected on VM 1h = Overvoltage condition is detected on VM
1	OT	R	0h	Overtemperature Fault Status Bit 0h = No overtemperature warning / shutdown is detected 1h = Overtemperature warning / shutdown is detected
0	FAULT	R	0h	Device Fault Bit 0h = No fault condition is detected 1h = Fault condition is detected

### 8.6.1.2 Status\_Register\_1 Register (Offset = 1h) [Reset = 00h]

Status\_Register\_1 is shown in [Status\\_Register\\_1 Register](#) and described in [Status\\_Register\\_1 Register Field Descriptions](#).

Return to the [STATUS Registers](#).

图 8-50. Status\_Register\_1 Register

7	6	5	4	3	2	1	0
OTW	OTS	OCP_HC	OCL_LC	OCP_HB	OCP_LB	OCP_HA	OCP_LA
R-0h	R-0h	R-0h	R-0h	R-0h	R-0h	R-0h	R-0h

表 8-14. Status\_Register\_1 Register Field Descriptions

Bit	Field	Type	Reset	Description
7	OTW	R	0h	Overtemperature Warning Status Bit 0h = No overtemperature warning is detected 1h = Overtemperature warning is detected
6	OTS	R	0h	Overtemperature Shutdown Status Bit 0h = No overtemperature shutdown is detected 1h = Overtemperature shutdown is detected
5	OCP_HC	R	0h	Overcurrent Status on High-side switch of OUTC 0h = No overcurrent detected on high-side switch of OUTC 1h = Overcurrent detected on high-side switch of OUTC
4	OCL_LC	R	0h	Overcurrent Status on Low-side switch of OUTC 0h = No overcurrent detected on low-side switch of OUTC 1h = Overcurrent detected on low-side switch of OUTC
3	OCP_HB	R	0h	Overcurrent Status on High-side switch of OUTB 0h = No overcurrent detected on high-side switch of OUTB 1h = Overcurrent detected on high-side switch of OUTB
2	OCP_LB	R	0h	Overcurrent Status on Low-side switch of OUTB 0h = No overcurrent detected on low-side switch of OUTB 1h = Overcurrent detected on low-side switch of OUTB
1	OCP_HA	R	0h	Overcurrent Status on High-side switch of OUTA 0h = No overcurrent detected on high-side switch of OUTA 1h = Overcurrent detected on high-side switch of OUTA
0	OCP_LA	R	0h	Overcurrent Status on Low-side switch of OUTA 0h = No overcurrent detected on low-side switch of OUTA 1h = Overcurrent detected on low-side switch of OUTA

### 8.6.1.3 Status\_Register\_2 Register (Offset = 2h) [Reset = 00h]

Status\_Register\_2 is shown in [Status\\_Register\\_2 Register](#) and described in [Status\\_Register\\_2 Register Field Descriptions](#).

Return to the [STATUS Registers](#).

图 8-51. Status\_Register\_2 Register

7	6	5	4	3	2	1	0
RESERVED	OTP_ERR	BUCK_OCP	BUCK_UV	VCP_UV	SPI_PARITY	SPI_SCLK_FLT	SPI_ADDR_FLT
R-0-0h	R-0h	R-0h	R-0h	R-0h	R-0-0h	R-0h	R-0h

表 8-15. Status\_Register\_2 Register Field Descriptions

Bit	Field	Type	Reset	Description
7	RESERVED	R-0	0h	Reserved
6	OTP_ERR	R	0h	One Time Programmability Error 0h = No OTP error is detected 1h = OTP Error is detected
5	BUCK_OCP	R	0h	Buck Regulator Overcurrent Status Bit 0h = No buck regulator overcurrent is detected 1h = Buck regulator overcurrent is detected
4	BUCK_UV	R	0h	Buck Regulator Undervoltage Status Bit 0h = No buck regulator undervoltage is detected 1h = Buck regulator undervoltage is detected
3	VCP_UV	R	0h	Charge Pump Undervoltage Status Bit 0h = No charge pump undervoltage is detected 1h = Charge pump undervoltage is detected
2	SPI_PARITY	R-0	0h	SPI Parity Error Bit 0h = No SPI parity error is detected 1h = SPI parity error is detected
1	SPI_SCLK_FLT	R	0h	SPI Clock Framing Error Bit 0h = No SPI clock framing error is detected 1h = SPI clock framing error is detected
0	SPI_ADDR_FLT	R	0h	SPI Address Error Bit 0h = No SPI address fault is detected (due to accessing non-user register) 1h = SPI address fault is detected

## 8.6.2 CONTROL Registers

[CONTROL Registers](#) lists the memory-mapped registers for the CONTROL registers. All register offset addresses not listed in [CONTROL Registers](#) should be considered as reserved locations and the register contents should not be modified.

**表 8-16. CONTROL Registers**

Offset	Acronym	Register Name	Section
3h	Control_Register_1	Control Register 1	<a href="#">节 8.6.2.1</a>
4h	Control_Register_2A	Control Register 2A	<a href="#">节 8.6.2.2</a>
5h	Control_Register_3	Control Register 3	<a href="#">节 8.6.2.3</a>
6h	Control_Register_4	Control Register 4	<a href="#">节 8.6.2.4</a>
7h	Control_Register_5	Control Register 5	<a href="#">节 8.6.2.5</a>
8h	Control_Register_6	Control Register 6	<a href="#">节 8.6.2.6</a>
9h	Control_Register_7	Control Register 7	<a href="#">节 8.6.2.7</a>
Ah	Control_Register_8	Control Register 8	<a href="#">节 8.6.2.8</a>
Bh	Control_Register_9	Control Register 9	<a href="#">节 8.6.2.9</a>
Ch	Control_Register_10	Control Register 10	<a href="#">节 8.6.2.10</a>

Complex bit access types are encoded to fit into small table cells. [CONTROL Access Type Codes](#) shows the codes that are used for access types in this section.

**表 8-17. CONTROL Access Type Codes**

Access Type	Code	Description
<b>Read Type</b>		
R	R	Read
R-0	R-0	Read Returns 0s
<b>Write Type</b>		
W	W	Write
W1C	W1C	Write 1 to clear
WAPU	WAPU	Write Atomic write with password unlock
<b>Reset or Default Value</b>		
-n		Value after reset or the default value

### 8.6.2.1 Control\_Register\_1 Register (Offset = 3h) [Reset = 00h]

Control\_Register\_1 is shown in [Control\\_Register\\_1 Register](#) and described in [Control\\_Register\\_1 Register Field Descriptions](#).

Return to the [CONTROL Registers](#).

图 8-52. Control\_Register\_1 Register

7	6	5	4	3	2	1	0
RESERVED					REG_LOCK		
R-0-0h					R/WAPU-0h		

表 8-18. Control\_Register\_1 Register Field Descriptions

Bit	Field	Type	Reset	Description
7-3	RESERVED	R-0	0h	Reserved
2-0	REG_LOCK	R/WAPU	0h	Register Lock Bits 0h = No effect unless locked or unlocked 1h = No effect unless locked or unlocked 2h = No effect unless locked or unlocked 3h = Write 011b to this register to unlock all registers 4h = No effect unless locked or unlocked 5h = No effect unless locked or unlocked 6h = Write 110b to lock the settings by ignoring further register writes except to these bits and address 0x03h bits 2-0. 7h = No effect unless locked or unlocked

### 8.6.2.2 Control\_Register\_2A Register (Offset = 4h) [Reset = 60h]

Control\_Register\_2A is shown in [Control\\_Register\\_2A Register](#) and described in [Control\\_Register\\_2A Register Field Descriptions](#).

Return to the [CONTROL Registers](#).

**图 8-53. Control\_Register\_2A Register**

<b>7</b>	<b>6</b>	<b>5</b>	<b>4</b>	<b>3</b>	<b>2</b>	<b>1</b>	<b>0</b>
RESERVED		SDO_MODE	SLEW		PWM_MODE		CLR_FLT
R/W-1h		R/W-1h	R/W-0h		R/W-0h		W1C-0h

**表 8-19. Control\_Register\_2A Register Field Descriptions**

Bit	Field	Type	Reset	Description
7-6	RESERVED	R/W	1h	Reserved
5	SDO_MODE	R/W	1h	SDO Mode Setting 0h = SDO IO in Open Drain Mode 1h = SDO IO in Push Pull Mode
4-3	SLEW	R/W	0h	Slew Rate Settings 0h = Slew rate is 25 V/μs 1h = Slew rate is 50 V/μs 2h = Slew rate is 125 V/μs 3h = Slew rate is 200 V/μs
2-1	PWM_MODE	R/W	0h	Device Mode Selection 0h = Asynchronous rectification with analog Hall 1h = Asynchronous rectification with digital Hall 2h = Synchronous rectification with analog Hall 3h = Synchronous rectification with digital Hall
0	CLR_FLT	W1C	0h	Clear Fault 0h = No clear fault command is issued 1h = To clear the latched fault bits. This bit automatically resets after being written.

### 8.6.2.3 Control\_Register\_3 Register (Offset = 5h) [Reset = 46h]

Control\_Register\_3 is shown in [Control\\_Register\\_3 Register](#) and described in [Control\\_Register\\_3 Register Field Descriptions](#).

Return to the [CONTROL Registers](#).

图 8-54. Control\_Register\_3 Register

7	6	5	4	3	2	1	0
RESERVED	RESERVED	RESERVED	PWM_100_DUTY_SEL	OVP_SEL	OVP_EN	RESERVED	OTW_REP
R-0-0h	R/W-1h	R/W-0h	R/W-0h	R/W-0h	R/W-1h	R/W-1h	R/W-0h

表 8-20. Control\_Register\_3 Register Field Descriptions

Bit	Field	Type	Reset	Description
7	RESERVED	R-0	0h	Reserved
6	RESERVED	R/W	1h	Reserved
5	RESERVED	R/W	0h	Reserved
4	PWM_100_DUTY_SEL	R/W	0h	Frequency of PWM at 100% Duty Cycle 0h = 20KHz 1h = 40KHz
3	OVP_SEL	R/W	0h	Overvoltage Level Setting 0h = VM overvoltage level is 34-V 1h = VM overvoltage level is 22-V
2	OVP_EN	R/W	1h	Overvoltage Enable Bit 0h = Overvoltage protection is disabled 1h = Overvoltage protection is enabled
1	RESERVED	R/W	1h	Reserved
0	OTW_REP	R/W	0h	Overtemperature Warning Reporting Bit 0h = Over temperature reporting on nFAULT is disabled 1h = Over temperature reporting on nFAULT is enabled

### 8.6.2.4 Control\_Register\_4 Register (Offset = 6h) [Reset = 10h]

Control\_Register\_4 is shown in [Control\\_Register\\_4 Register](#) and described in [Control\\_Register\\_4 Register Field Descriptions](#).

Return to the [CONTROL Registers](#).

图 8-55. Control\_Register\_4 Register

7	6	5	4	3	2	1	0
DRV_OFF	OCP_CBC	OCP_DEG		OCP_RETRY	OCP_LVL	OCP_MODE	
R/W-0h	R/W-0h	R/W-1h		R/W-0h	R/W-0h	R/W-0h	

表 8-21. Control\_Register\_4 Register Field Descriptions

Bit	Field	Type	Reset	Description
7	DRV_OFF	R/W	0h	Driver OFF Bit 0h = No Action 1h = Enter Low Power Standby Mode
6	OCP_CBC	R/W	0h	OCP PWM Cycle Operation Bit 0h = OCP clearing in PWM input cycle change is disabled 1h = OCP clearing in PWM input cycle change is enabled
5-4	OCP_DEG	R/W	1h	OCP Deglitch Time Settings 0h = OCP deglitch time is 0.2 $\mu$ s 1h = OCP deglitch time is 0.6 $\mu$ s 2h = OCP deglitch time is 1.25 $\mu$ s 3h = OCP deglitch time is 1.6 $\mu$ s
3	OCP_RETRY	R/W	0h	OCP Retry Time Settings 0h = OCP retry time is 5 ms 1h = OCP retry time is 500 ms
2	OCP_LVL	R/W	0h	Overcurrent Level Setting 0h = OCP level is 16 A 1h = OCP level is 24 A
1-0	OCP_MODE	R/W	0h	OCP Fault Options 0h = Overcurrent causes a latched fault 1h = Overcurrent causes an automatic retrying fault 2h = Overcurrent is report only but no action is taken 3h = Overcurrent is not reported and no action is taken

### 8.6.2.5 Control\_Register\_5 Register (Offset = 7h) [Reset = 00h]

Control\_Register\_5 is shown in [Control\\_Register\\_5 Register](#) and described in [Control\\_Register\\_5 Register Field Descriptions](#).

Return to the [CONTROL Registers](#).

图 8-56. Control\_Register\_5 Register

7	6	5	4	3	2	1	0
RESERVED	ILIM_RECIR	RESERVED	RESERVED	EN_AAR	EN_ASR	CSA_GAIN	
R/W-0h	R/W-0h	R/W-0h	R/W-0h	R/W-0h	R/W-0h	R/W-0h	

表 8-22. Control\_Register\_5 Register Field Descriptions

Bit	Field	Type	Reset	Description
7	RESERVED	R/W	0h	Reserved
6	ILIM_RECIR	R/W	0h	Current Limit Recirculation Settings 0h = Current recirculation through FETs (Brake Mode) 1h = Current recirculation through diodes (Coast Mode)
5	RESERVED	R/W	0h	Reserved
4	RESERVED	R/W	0h	Reserved
3	EN_AAR	R/W	0h	Active Asynchronous Rectification Enable Bit 0h = AAR mode is disabled 1h = AAR mode is enabled
2	EN_ASR	R/W	0h	Active Synchronous Rectification Enable Bit 0h = ASR mode is disabled 1h = ASR mode is enabled
1-0	CSA_GAIN	R/W	0h	Current Sense Amplifier's Gain Settings 0h = CSA gain is 0.15 V/A 1h = CSA gain is 0.3 V/A 2h = CSA gain is 0.6 V/A 3h = CSA gain is 1.2 V/A

### 8.6.2.6 Control\_Register\_6 Register (Offset = 8h) [Reset = 00h]

Control\_Register\_6 is shown in [Control\\_Register\\_6 Register](#) and described in [Control\\_Register\\_6 Register Field Descriptions](#).

Return to the [CONTROL Registers](#).

**图 8-57. Control\_Register\_6 Register**

7	6	5	4	3	2	1	0
RESERVED		RESERVED	BUCK_PS_DIS	BUCK_CL	BUCK_SEL		BUCK_DIS
R-0-0h		R/W-0h	R/W-0h	R/W-0h	R/W-0h		R/W-0h

**表 8-23. Control\_Register\_6 Register Field Descriptions**

Bit	Field	Type	Reset	Description
7-6	RESERVED	R-0	0h	Reserved
5	RESERVED	R/W	0h	Reserved
4	BUCK_PS_DIS	R/W	0h	Buck Power Sequencing Disable Bit 0h = Buck power sequencing is enabled 1h = Buck power sequencing is disabled
3	BUCK_CL	R/W	0h	Buck Current Limit Setting 0h = Buck regulator current limit is set to 600 mA 1h = Buck regulator current limit is set to 150 mA
2-1	BUCK_SEL	R/W	0h	Buck Voltage Selection 0h = Buck voltage is 3.3 V 1h = Buck voltage is 5.0 V 2h = Buck voltage is 4.0 V 3h = Buck voltage is 5.7 V
0	BUCK_DIS	R/W	0h	Buck Disable Bit 0h = Buck regulator is enabled 1h = Buck regulator is disabled

### 8.6.2.7 Control\_Register\_7 Register (Offset = 9h) [Reset = 01h]

Control\_Register\_7 is shown in [Control\\_Register\\_7 Register](#) and described in [Control\\_Register\\_7 Register Field Descriptions](#).

Return to the [CONTROL Registers](#).

图 8-58. Control\_Register\_7 Register

7	6	5	4	3	2	1	0
RESERVED			HALL_HYS	BRAKE_MODE	COAST	BRAKE	DIR
R-0-0h			R/W-0h	R/W-0h	R/W-0h	R/W-0h	R/W-1h

表 8-24. Control\_Register\_7 Register Field Descriptions

Bit	Field	Type	Reset	Description
7-5	RESERVED	R-0	0h	Reserved
4	HALL_HYS	R/W	0h	Hall Comparator Hysteresis Settings 0h = 5 mV 1h = 50 mV
3	BRAKE_MODE	R/W	0h	Brake Mode Setting 0h = Device operation is braking in brake mode 1h = Device operation is coasting in brake mode
2	COAST	R/W	0h	Coast Bit 0h = Device coast mode is disabled 1h = Device coast mode is enabled
1	BRAKE	R/W	0h	Brake Bit 0h = Device brake mode is disabled 1h = Device brake mode is enabled
0	DIR	R/W	1h	Direction Bit 0h = Motor direction is set to clockwise direction 1h = Motor direction is set to anti-clockwise direction

### 8.6.2.8 Control\_Register\_8 Register (Offset = Ah) [Reset = 41h]

Control\_Register\_8 is shown in [Control\\_Register\\_8 Register](#) and described in [Control\\_Register\\_8 Register Field Descriptions](#).

Return to the [CONTROL Registers](#).

**图 8-59. Control\_Register\_8 Register**

7	6	5	4	3	2	1	0
FG_MODE		RESERVED	MTR_LOCK_RETRY	MTR_LOCK_TDET		MTR_LOCK_MODE	
R/W-1h		R-0-0h	R/W-0h	R/W-0h		R/W-1h	

**表 8-25. Control\_Register\_8 Register Field Descriptions**

Bit	Field	Type	Reset	Description
7-6	FG_MODE	R/W	1h	Electrical Frequency Generation Output Mode Bits 0h = FGOUT frequency is commutation frequency 1h = FGOUT frequency is 1/2 of commutation frequency 2h = FGOUT frequency is 1/4 of commutation frequency 3h = FGOUT frequency is 1/8 of commutation frequency
5	RESERVED	R-0	0h	Reserved
4	MTR_LOCK_RETRY	R/W	0h	Motor Lock Retry Time Settings 0h = 500 ms 1h = 5000 ms
3-2	MTR_LOCK_TDET	R/W	0h	Motor Lock Detection Time Settings 0h = 300 ms 1h = 500 ms 2h = 1000 ms 3h = 5000 ms
1-0	MTR_LOCK_MODE	R/W	1h	Motor Lock Fault Options 0h = Motor lock causes a latched fault 1h = Motor lock causes an automatic retrying fault 2h = Motor lock is report only but no action is taken 3h = Motor lock is not reported and no action is taken

### 8.6.2.9 Control\_Register\_9 Register (Offset = Bh) [Reset = 00h]

Control\_Register\_9 is shown in [Control\\_Register\\_9 Register](#) and described in [Control\\_Register\\_9 Register Field Descriptions](#).

Return to the [CONTROL Registers](#).

图 8-60. Control\_Register\_9 Register

7	6	5	4	3	2	1	0
RESERVED					ADVANCE_LVL		
R-0-0h					R/W-0h		

表 8-26. Control\_Register\_9 Register Field Descriptions

Bit	Field	Type	Reset	Description
7-3	RESERVED	R-0	0h	Reserved
2-0	ADVANCE_LVL	R/W	0h	Phase Advance Setting 0h = 0° 1h = 4° 2h = 7° 3h = 11° 4h = 15° 5h = 20° 6h = 25° 7h = 30°

### 8.6.2.10 Control\_Register\_10 Register (Offset = Ch) [Reset = 00h]

Control\_Register\_10 is shown in [Control\\_Register\\_10 Register](#) and described in [Control\\_Register\\_10 Register Field Descriptions](#).

Return to the [CONTROL Registers](#).

**图 8-61. Control\_Register\_10 Register**

7	6	5	4	3	2	1	0
RESERVED			DLYCMP_EN	DLY_TARGET			
R-0-0h			R/W-0h	R/W-0h			

**表 8-27. Control\_Register\_10 Register Field Descriptions**

Bit	Field	Type	Reset	Description
7-5	RESERVED	R-0	0h	Reserved
4	DLYCMP_EN	R/W	0h	Driver Delay Compensation enable 0h = Disable 1h = Enable
3-0	DLY_TARGET	R/W	0h	Delay Target for Driver Delay Compensation 0h = 0 us 1h = 0.4 us 2h = 0.6 us 3h = 0.8 us 4h = 1 us 5h = 1.2 us 6h = 1.4 us 7h = 1.6 us 8h = 1.8 us 9h = 2 us Ah = 2.2 us Bh = 2.4 us Ch = 2.6 us Dh = 2.8 us Eh = 3 us Fh = 3.2 us

## 9 Application and Implementation

### Note

以下应用部分中的信息不属于 TI 器件规格的范围，TI 不担保其准确性和完整性。TI 的客户应负责确定器件是否适用于其应用。客户应验证并测试其设计，以确保系统功能。

### 9.1 Application Information

The MCT8316Z can be used to drive Brushless-DC motors. The following design procedure can be used to configure the MCT8316Z.



图 9-1. Primary Application Schematics for MCT8316ZT (hardware variant)



图 9-2. Primary Application Schematics for MCT8316ZR (SPI variant)

## 9.2 Hall Sensor Configuration and Connection

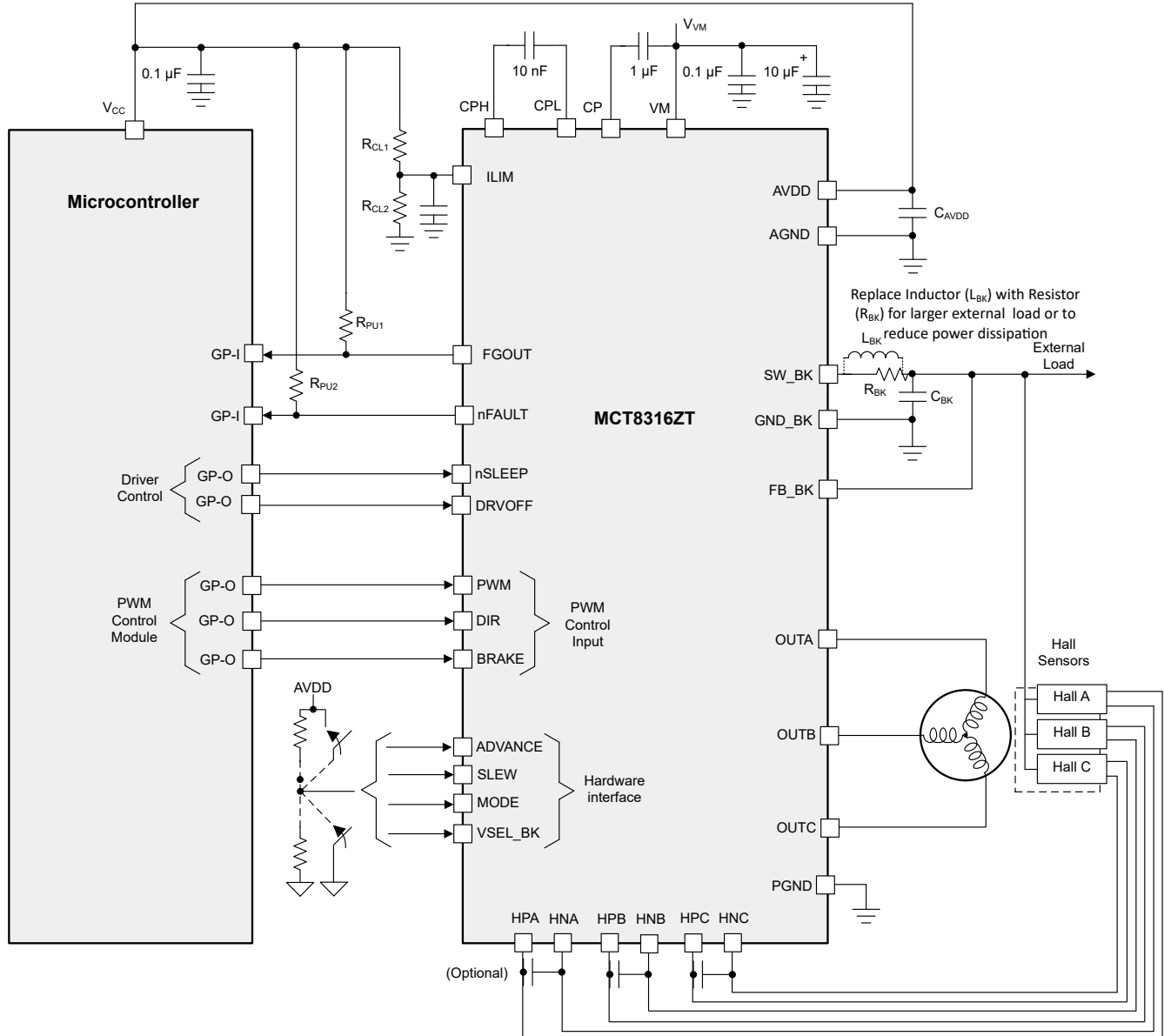
The combinations of Hall sensor connections in this section are common connections.

### 9.2.1 Typical Configuration

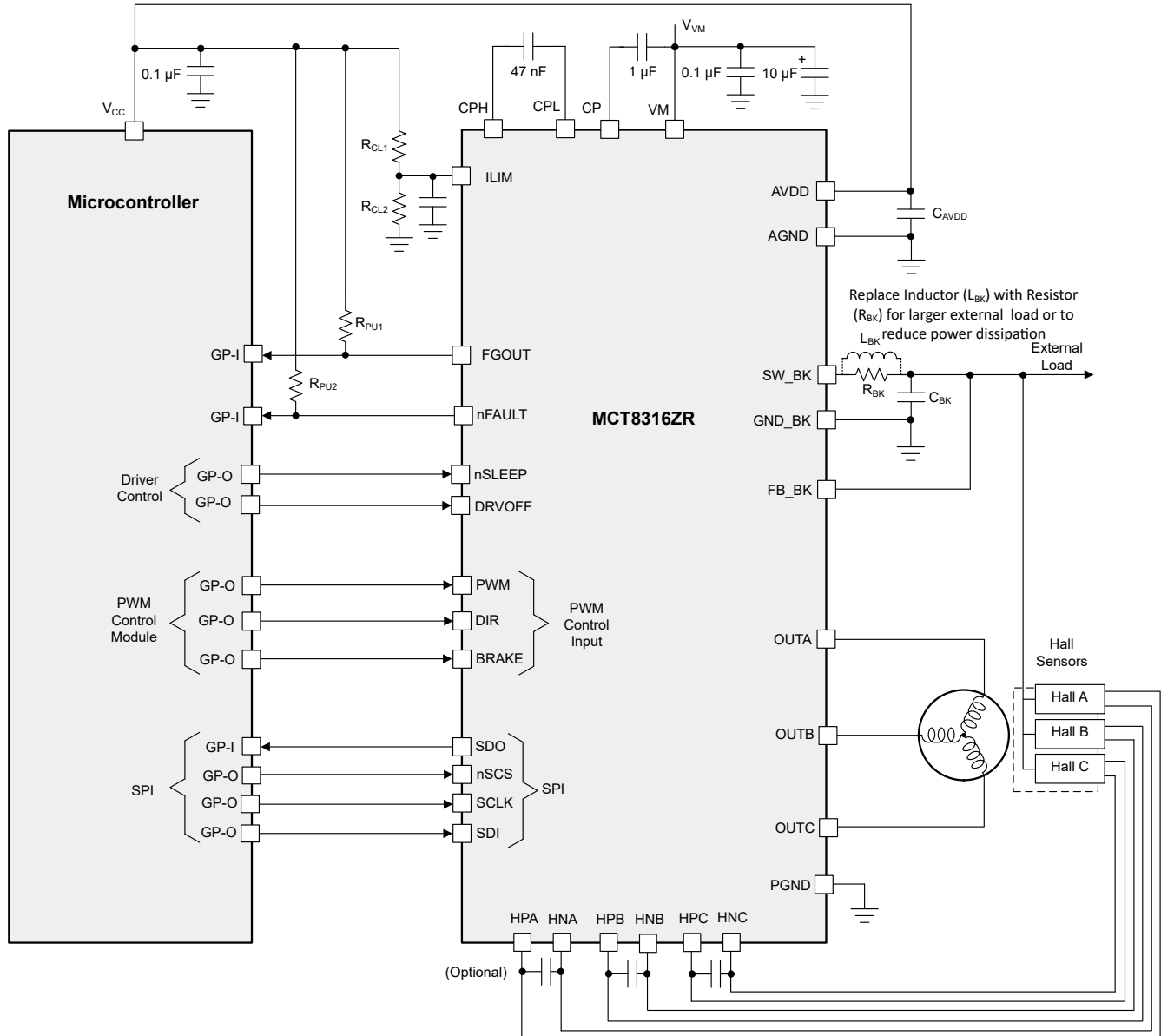
The Hall sensor inputs on the MCT8316Z device can interface with a variety of Hall sensors. Typically, a Hall element is used, which outputs a differential signal. To use this type of sensor, the AVDD regulator can be used to power the Hall sensor. 图 9-3 shows the connections.



图 9-3. Typical Hall Sensor Configuration

Because the amplitude of the Hall-sensor output signal is very low, capacitors are often placed across the Hall inputs to help reject noise coupled from the motor. Capacitors with a value of 1 nF to 100 nF are typically used.

### 9.2.2 Open Drain Configuration

Some motors use digital Hall sensors with open-drain outputs. These sensors can also be used with the MCT8316Z device, with the addition of a few resistors as shown in 图 9-4.

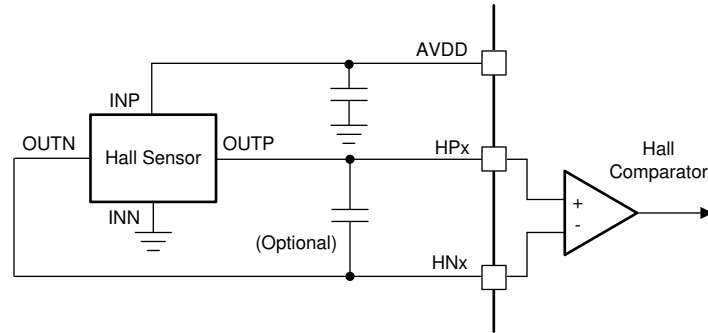

图 9-4. Open-Drain Hall Sensor Configuration

The negative (HNx) inputs are biased to  $AVDD / 2$  by a pair of resistors between the AVDD pin and ground. For open-collector Hall sensors, an additional pullup resistor to the VREG pin is required on the positive (HPx) input. Again, the AVDD output can usually be used to supply power to the Hall sensors.

### 9.2.3 Series Configuration

Hall elements are also connected in series or parallel depending upon the Hall sensor current/voltage requirement. 图 9-5 shows the series connection of Hall sensors powered via the MCT8316Z internal LDO (AVDD). This configuration is used if the current requirement per Hall sensor is high (>10 mA)

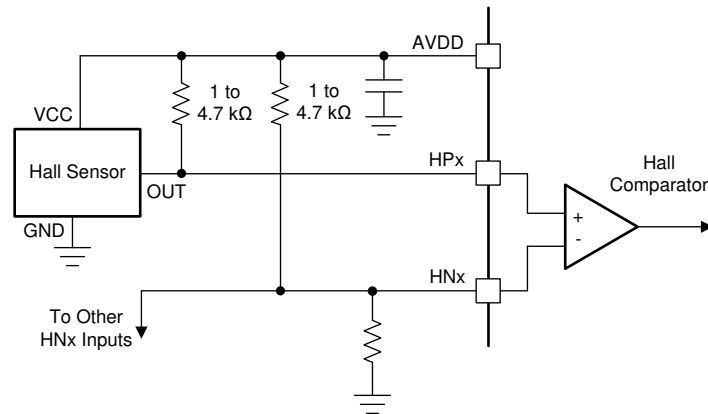

图 9-5. Hall Sensor Connected in Series Configuration

### 9.2.4 Parallel Configuration

图 9-6 shows the parallel connection of Hall sensors which is powered by the AVDD. This configuration can be used if the current requirement per Hall sensor is low ( $<10$  mA).

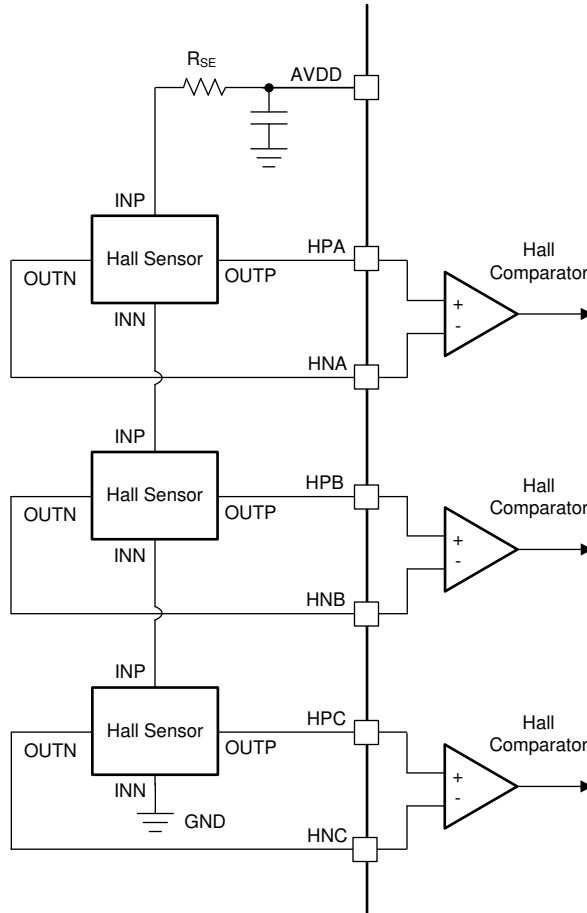

图 9-6. Hall Sensors Connected in Parallel Configuration

## 9.3 Typical Applications

### 9.3.1 Three-Phase Brushless-DC Motor Control With Current Limit

In this application, the MCT8316Z is used to drive a brushless-DC motor with current limit up to 100% duty cycle. The following design procedure can be used to configure the MCT8316Z in current limit mode.

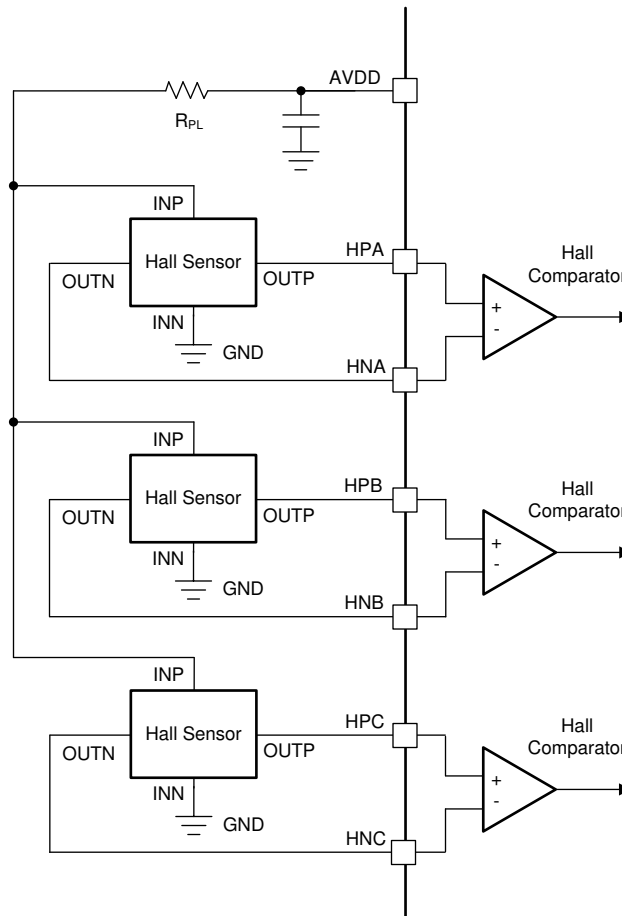
#### 9.3.1.1 Detailed Design Procedure

表 9-1 lists the example input parameters for the system design.

**表 9-1. Design Parameters**

DESIGN PARAMETERS	REFERENCE	EXAMPLE VALUE
Supply voltage	$V_{VM}$	24 V
Motor peak current	$I_{PEAK}$	2 A
PWM Frequency	$f_{PWM}$	50 kHz
Slew Rate Setting	SR	200 V/ $\mu$ s
Buck regulator output voltage	$V_{BK}$	3.3 V

##### 9.3.1.1.1 Motor Voltage

Brushless-DC motors are typically rated for a certain voltage (for example 12 V or 24 V). Operating a motor at a higher voltage corresponds to a lower drive current to obtain the same motor power. Operating at lower voltages generally allows for more accurate control of phase currents. The MCT8316Z functions down to a supply of 4.5V. A higher operating voltage also corresponds to a higher obtainable rpm. The MCT8316Z allows for a range of possible operating voltages because of a maximum VM rating of 40 V.

##### 9.3.1.1.2 Using Active Demagnetization

Active demagnetization reduces power losses in the device by turning on the MOSFETs automatically when the body diode starts conducting to reduce diode conduction losses. It is used in trapezoidal commutation when switching commutation states (turning a high-side MOSFET off and another high-side MOSFET on while keeping a low-side MOSFET on). Active demagnetization is enabled when EN\_ASR and EN\_AAR bits are set in the SPI variant or MODE pin is set to Mode 5, Mode 6, or Mode 7 in the H/W variant.

When switching commutation states with active demagnetization disabled, dead time is inserted and the low-side MOSFET's body diode conducts while turning another high-side MOSFET on to continue sourcing current through the motor. This conduction period causes higher power losses due to the forward-bias voltage of the diode and slower dissipation of current. 图 9-7 shows the body diode conducting when switching commutation states.



图 9-7. Active demagnetization disabled in MCT8316Z

When active demagnetization is enabled, the AD\_HS and AD\_LS comparators detect when the sense FET voltage is higher or lower than the programmed threshold. After the dead time period, if the threshold is exceeded for a fixed amount of time, the body diode is conducting and the logic core turns the low-side FET on to provide a conduction path with smaller power losses. Once the  $V_{DS}$  voltage is below the comparator threshold, the MOSFET turns off and current briefly conducts through the body diode until the current completely decays to zero. This is shown in 图 9-8.

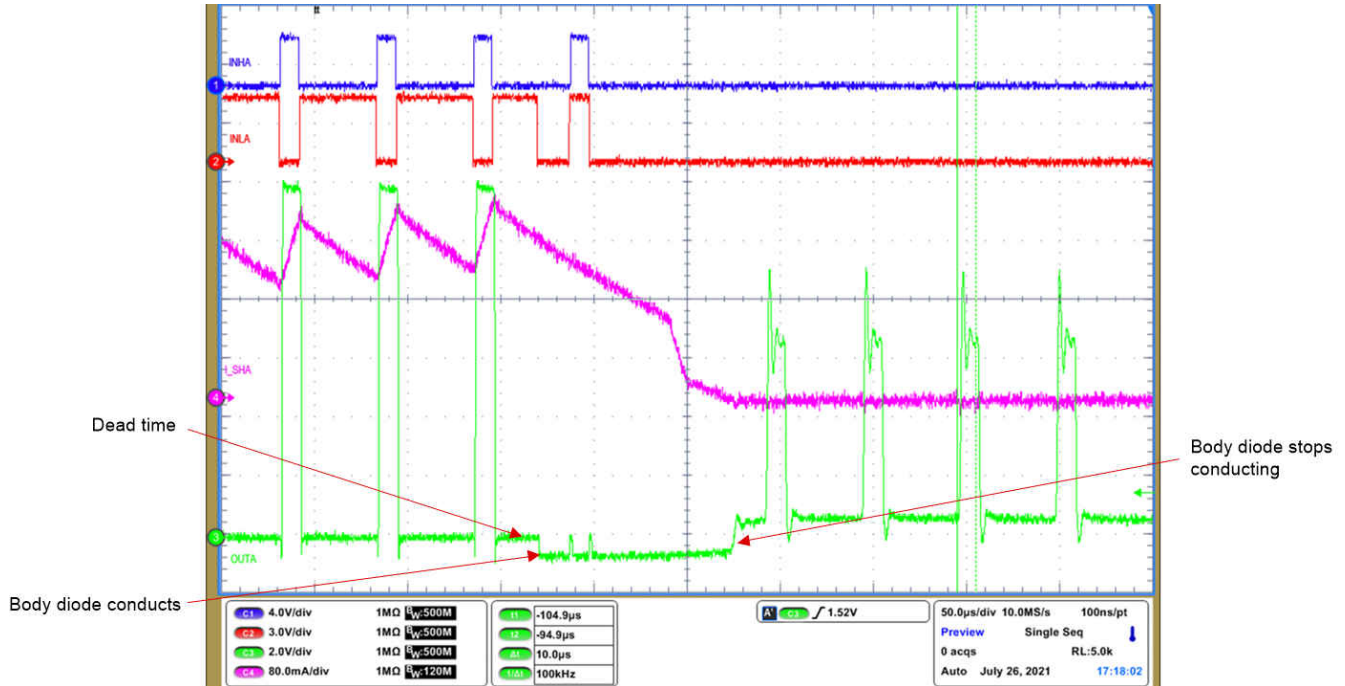

图 9-8. Active demagnetization enabled in MCT8316Z

### 9.3.1.1.3 Using Delay Compensation

Differences in delays of dead time and propagation delay can cause mismatch in the output timings of PWMs, which can lead to duty cycle distortion. In order to accommodate differences in propagation delay between various input conditions, the MCT8316ZR integrates a Delay Compensation feature.

Delay Compensation is used to match delay times for currents going into and out of phase by adding a variable delay time ( $t_{var}$ ) to match a preset target delay time. This delay time is configurable in SPI devices, and it is recommended in the datasheets to choose a target delay time that is equal to the propagation delay time plus the driver dead time ( $t_{pd} + t_{dead}$ ).

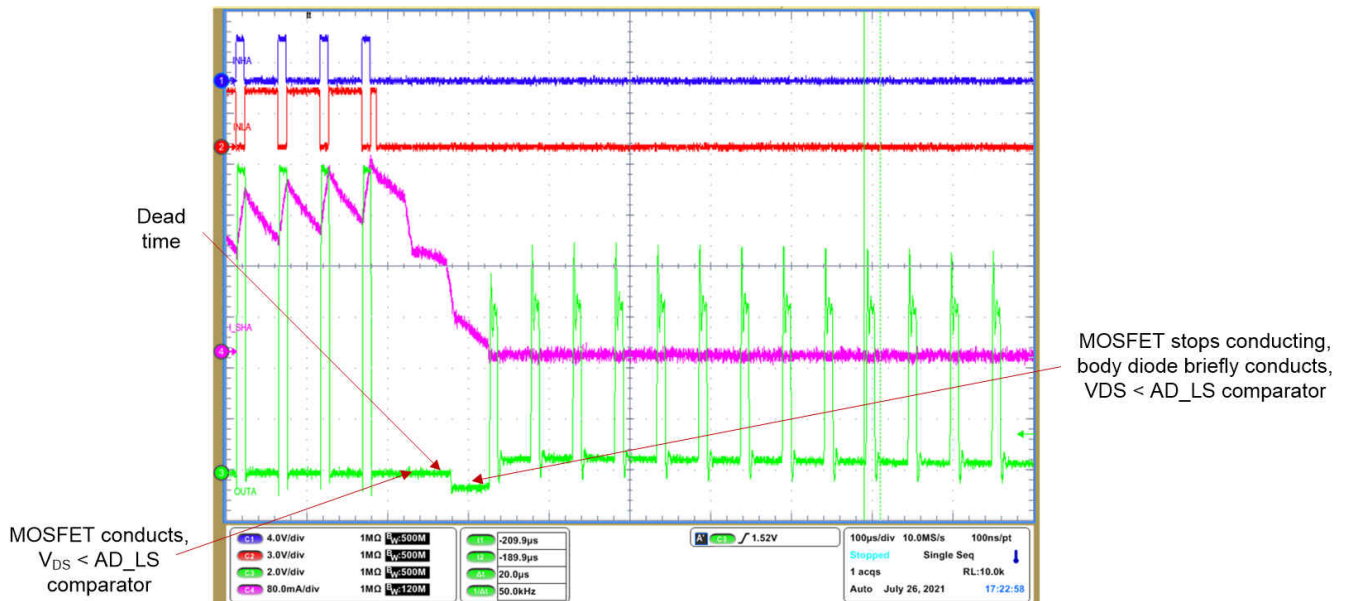
For an example of Delay Compensation implementation, please visit the [Delay and Dead Time in Integrated MOSFET Drivers](#) application note.

### 9.3.1.1.4 Using the Buck Regulator

In the MCT8316Z, the buck regulator components must be populated whether the buck is used or unused.

If unused, Resistor Mode should be configured by placing a small value resistor of 22-ohm for  $R_{BK}$  and a 6.3-V rated, 22- $\mu$ F capacitor for  $C_{BK}$  to minimize board space and reduce component cost. To disable the buck regulator, set the BUCK\_DIS in the SPI variant. The buck cannot be disabled in the Hardware variant.

If the buck regulator is used, either the Inductor or Resistor Mode can be selected. Inductor Mode allows a 22- $\mu$ H or 47- $\mu$ H inductor be used for  $L_{BK}$ .  $C_{BK}$  is recommended to be 22- $\mu$ F. Ensure an appropriate inductor is chosen to allow for maximum peak saturation current at a 20% inductance drop since the buck can supply up to 600-mA external current.

Resistor Mode allows for power to be dissipated in an external resistor if the load requirement is less than 40-mA. Ensure the resistor is rated for the power dissipation required at worst case VM voltage dropout. See [方程式 5](#), [方程式 6](#), and [方程式 7](#) to calculate the resistor power rating required for a 24-V rated system, 3.3V buck output voltage, and 20-mA load current.

$$P_{R_{BK}} > (V_M - V_{BK}) \times I_{BK} \quad (5)$$

$$P_{R_{BK}} > (24V - 3.3V) \times 20mA \quad (6)$$

$$P_{R_{BK}} > 0.434W \quad (7)$$

### 9.3.1.1.5 Power Dissipation and Junction Temperature Losses

To calculate the junction temperature of the MCT8316Z from power losses, use [方程式 8](#). Note that the thermal resistance  $\theta_{JA}$  depends on PCB configurations such as the ambient temperature, numbers of PCB layers, copper thickness on top and bottom layers, and the PCB area.

$$T_J[^\circ\text{C}] = P_{loss}[W] \times \theta_{JA}\left[\frac{^\circ\text{C}}{W}\right] + T_A[^\circ\text{C}] \quad (8)$$

### 9.3.1.2 Application Curves



图 9-9. Device Powerup with VM



图 9-10. Device Powerup with nSLEEP

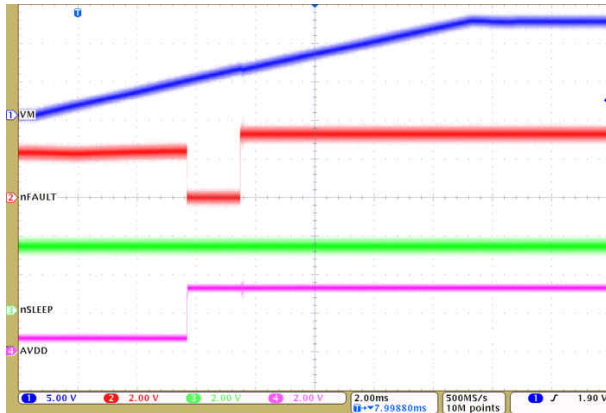

图 9-11. Driver PWM Operation

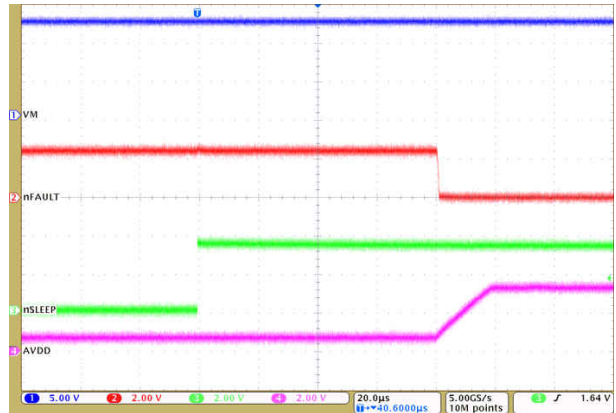

图 9-12. Driver PWM Operation with FGOUT

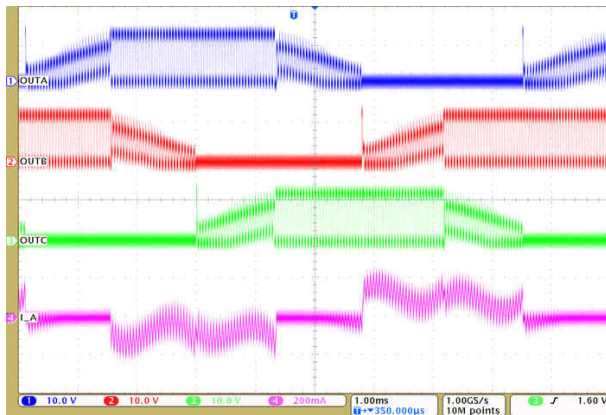

图 9-13. Power Management

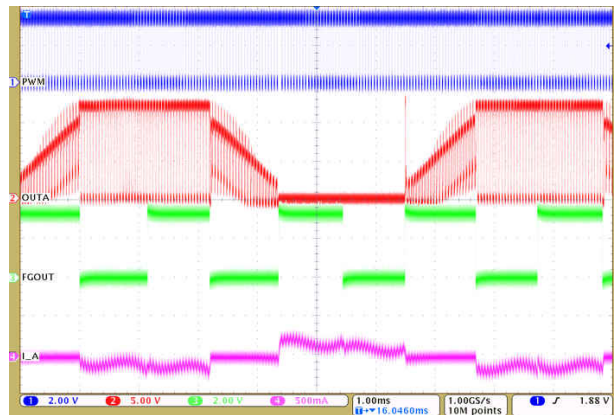

图 9-14. Driver PWM with Active Demagnetization (ASR and AAR)

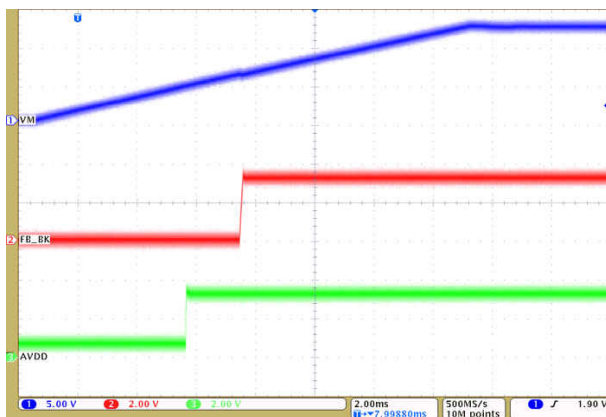

图 9-15. Driver PWM Operation with Current Limit

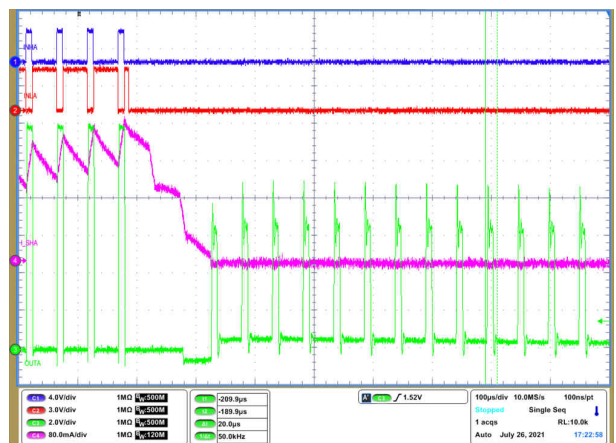

图 9-16. Driver 100% Operation with Current Chopping

## 10 Power Supply Recommendations

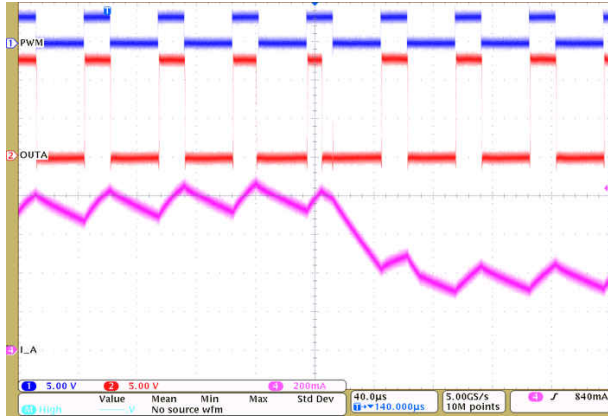
### 10.1 Bulk Capacitance

Having an appropriate local bulk capacitance is an important factor in motor drive system design. It is generally beneficial to have more bulk capacitance, while the disadvantages are increased cost and physical size.

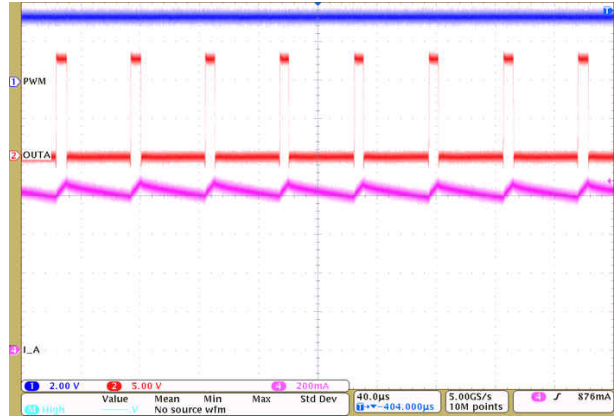
The amount of local capacitance needed depends on a variety of factors, including:

- The highest current required by the motor system
- The capacitance and current capability of the power supply
- The amount of parasitic inductance between the power supply and motor system
- The acceptable voltage ripple
- The type of motor used (brushed dc, brushless DC, stepper)
- The motor braking method

The inductance between the power supply and the motor drive system limits the rate current can change from the power supply. If the local bulk capacitance is too small, the system responds to excessive current demands or dumps from the motor with a change in voltage. When adequate bulk capacitance is used, the motor voltage remains stable and high current can be quickly supplied.

The data sheet generally provides a recommended value, but system-level testing is required to determine the appropriate sized bulk capacitor.



图 10-1. Example Setup of Motor Drive System With External Power Supply

The voltage rating for bulk capacitors should be higher than the operating voltage, to provide margin for cases when the motor transfers energy to the supply.

## 11 Layout

### 11.1 Layout Guidelines

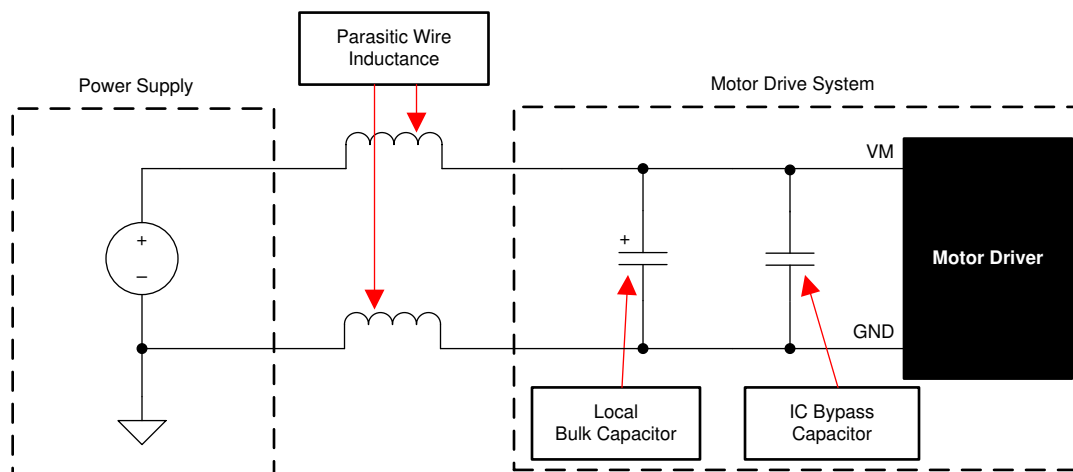
The bulk capacitor should be placed to minimize the distance of the high-current path through the motor driver device. The connecting metal trace widths should be as wide as possible, and numerous vias should be used when connecting PCB layers. These practices minimize inductance and allow the bulk capacitor to deliver high current.

Small-value capacitors such as the charge pump, AVDD, and VREF capacitors should be ceramic and placed closely to device pins.

The high-current device outputs should use wide metal traces.

To reduce noise coupling and EMI interference from large transient currents into small-current signal paths, grounding should be partitioned between PGND and AGND. TI recommends connecting all non-power stage circuitry (including the thermal pad) to AGND to reduce parasitic effects and improve power dissipation from the device. Optionally, GND\_BK can be split. Ensure grounds are connected through net-ties or wide resistors to reduce voltage offsets and maintain gate driver performance.

The device thermal pad should be soldered to the PCB top-layer ground plane. Multiple vias should be used to connect to a large bottom-layer ground plane. The use of large metal planes and multiple vias helps dissipate the  $I_2 \times RDS(on)$  heat that is generated in the device.

To improve thermal performance, maximize the ground area that is connected to the thermal pad ground across all possible layers of the PCB. Using thick copper pours can lower the junction-to-air thermal resistance and improve thermal dissipation from the die surface.

Separate the SW\_BUCK and FB\_BUCK traces with ground separation to reduce buck switching from coupling as noise into the buck outer feedback loop. Widen the FB\_BUCK trace as much as possible to allow for faster load switching.

[Recommended Layout Example for VQFN Package](#) shows a layout example for the MCT8316Z.

## 11.2 Layout Example

### Recommended Layout Example for VQFN Package

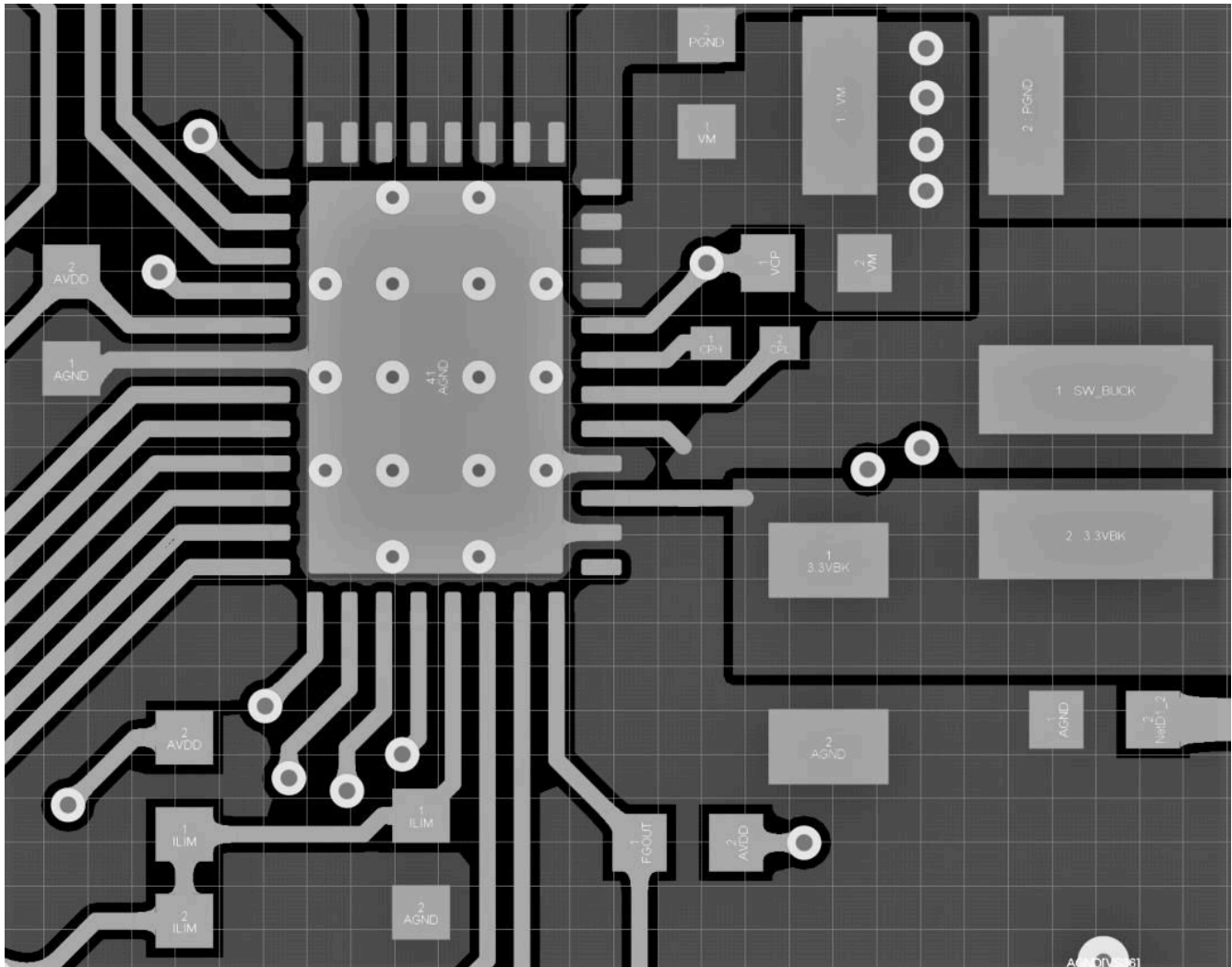

## 11.3 Thermal Considerations

The MCT8316Z has thermal shutdown (TSD) as previously described. A die temperature in excess of 150°C (minimally) disables the device until the temperature drops to a safe level.

Any tendency of the device to enter thermal shutdown is an indication of excessive power dissipation, insufficient heatsinking, or too high an ambient temperature.

### 11.3.1 Power Dissipation

The power dissipated in the output FET resistance, or  $R_{DS(on)}$  dominates power dissipation in the MCT8316Z.

At start-up and fault conditions, this current is much higher than normal running current; remember to take these peak currents and their duration into consideration.

The total device dissipation is the power dissipated in each of the three half-H-bridges added together.

The maximum amount of power that the device can dissipate depends on ambient temperature and heatsinking.

Note that  $R_{DS(on)}$  increases with temperature, so as the device heats, the power dissipation increases. Take this into consideration when sizing the heatsink.

A summary of equations for calculating each loss is shown below for trapezoidal control.

**表 11-1. MCT8316Z Power Losses for Trapezoidal Control**

Loss type	Trapezoidal
Standby power	$P_{standby} = VM \times I_{VM\_TA}$
LDO (from VM)	$P_{LDO} = (VM - V_{AVDD}) \times I_{AVDD}$
FET conduction	$P_{CON} = 2 \times I_{RMS(trap)} \times R_{ds,on(TA)}$
FET switching	$P_{SW} = I_{PK(trap)} \times V_{PK(trap)} \times t_{rise/fall} \times f_{PWM}$
Diode	$P_{diode} = I_{RMS(trap)} \times V_{diode} \times t_{diode} \times f_{PWM}$
Buck	$P_{BK} = 0.97 \times V_{BK} \times I_{BK}$

## 12 Device and Documentation Support

### 12.1 支持资源

[TI E2E™ 支持论坛](#)是工程师的重要参考资料，可直接从专家获得快速、经过验证的解答和设计帮助。搜索现有解答或提出自己的问题可获得所需的快速设计帮助。

链接的内容由各个贡献者“按原样”提供。这些内容并不构成 TI 技术规范，并且不一定反映 TI 的观点；请参阅 TI 的《使用条款》。

### 12.2 Trademarks

TI E2E™ is a trademark of Texas Instruments.

所有商标均为其各自所有者的财产。

### 12.3 Electrostatic Discharge Caution



This integrated circuit can be damaged by ESD. Texas Instruments recommends that all integrated circuits be handled with appropriate precautions. Failure to observe proper handling and installation procedures can cause damage.

ESD damage can range from subtle performance degradation to complete device failure. Precision integrated circuits may be more susceptible to damage because very small parametric changes could cause the device not to meet its published specifications.

### 12.4 术语表

[TI 术语表](#) 本术语表列出并解释了术语、首字母缩略词和定义。



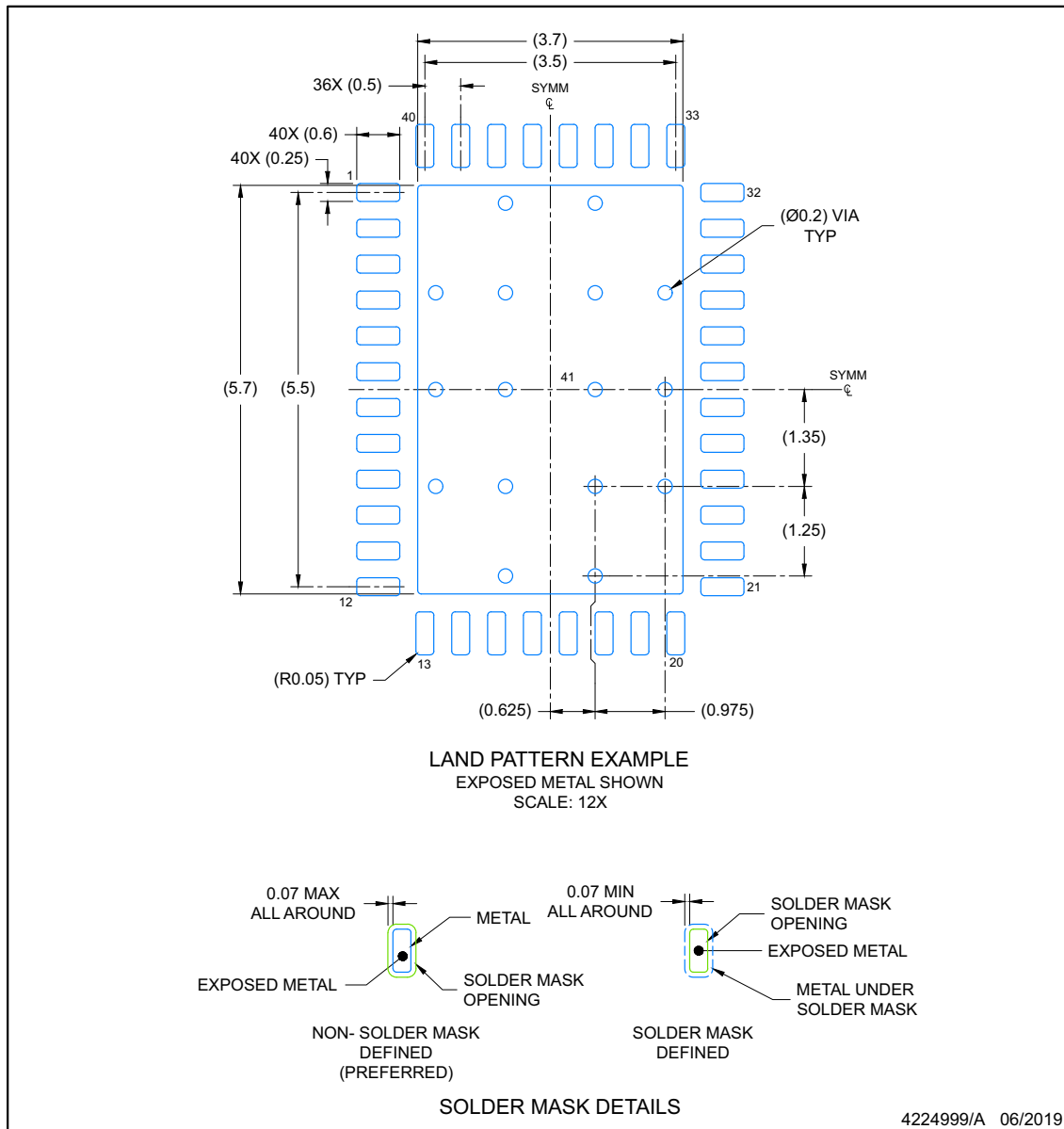

NOTES: (continued)

4. This package is designed to be soldered to a thermal pad on the board. For more information, see Texas Instruments literature number SLUA271 ([www.ti.com/lit/sluea271](http://www.ti.com/lit/sluea271)).
5. Vias are optional depending on application, refer to device data sheet. If any vias are implemented, refer to their locations shown on this view. It is recommended that vias under paste be filled, plugged or tented.

# EXAMPLE STENCIL DESIGN

RGF0040E

VQFN - 1 mm max height

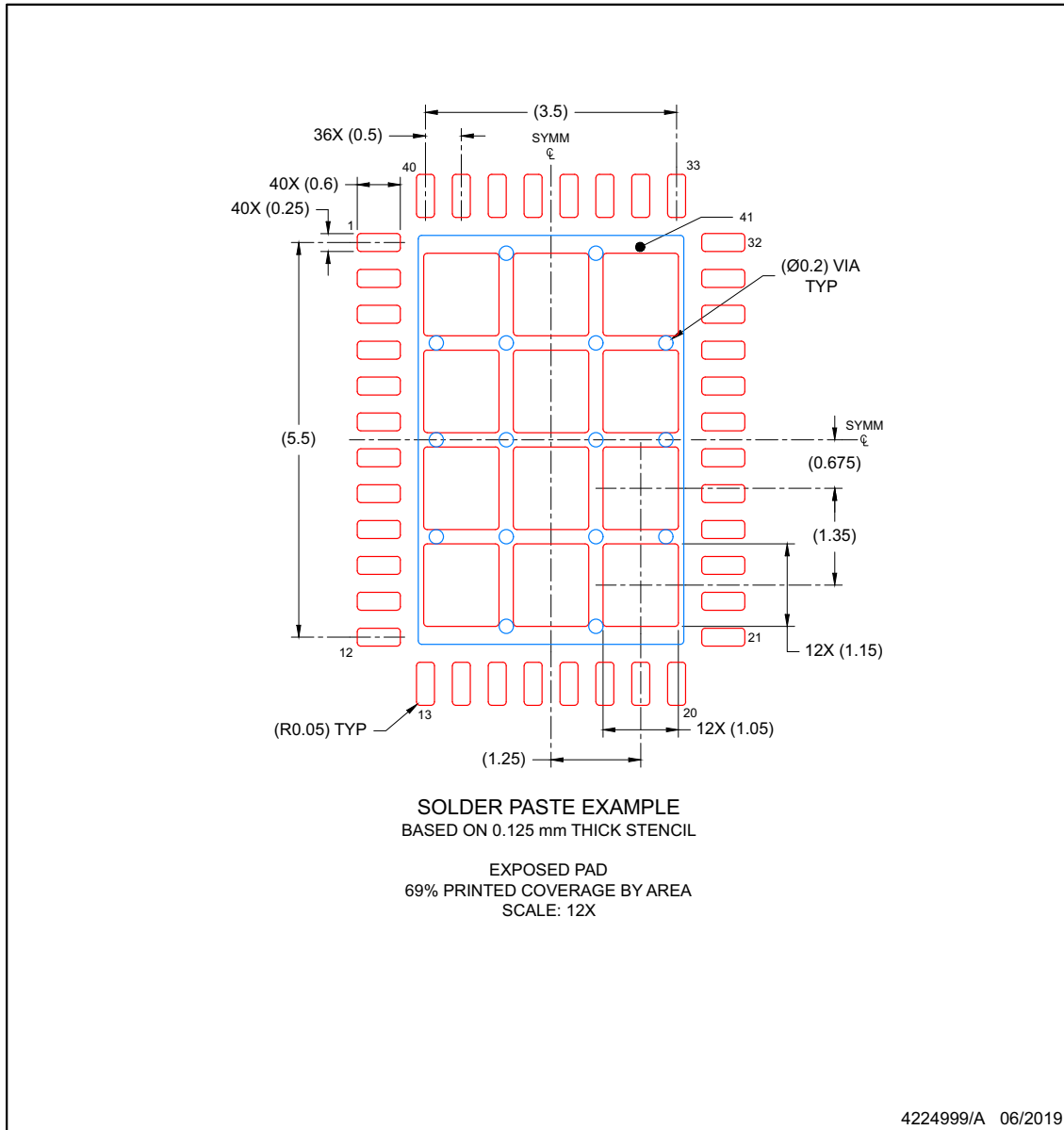

PLASTIC QUAD FLAT PACK- NO LEAD



NOTES: (continued)

6. Laser cutting apertures with trapezoidal walls and rounded corners may offer better paste release. IPC-7525 may have alternate design recommendations.

**PACKAGING INFORMATION**

Orderable Device	Status (1)	Package Type	Package Drawing	Pins	Package Qty	Eco Plan (2)	Lead finish/ Ball material (6)	MSL Peak Temp (3)	Op Temp (°C)	Device Marking (4/5)	Samples
MCT8316Z0RRGFR	ACTIVE	VQFN	RGF	40	3000	RoHS & Green	NIPDAU	Level-2-260C-1 YEAR	-40 to 125	MCT 8316ZR	
MCT8316Z0TRGFR	ACTIVE	VQFN	RGF	40	3000	RoHS & Green	NIPDAU	Level-2-260C-1 YEAR	-40 to 125	MCT 8316ZT	

(1) The marketing status values are defined as follows:

**ACTIVE:** Product device recommended for new designs.

**LIFEBUY:** TI has announced that the device will be discontinued, and a lifetime-buy period is in effect.

**NRND:** Not recommended for new designs. Device is in production to support existing customers, but TI does not recommend using this part in a new design.

**PREVIEW:** Device has been announced but is not in production. Samples may or may not be available.

**OBSOLETE:** TI has discontinued the production of the device.

(2) **RoHS:** TI defines "RoHS" to mean semiconductor products that are compliant with the current EU RoHS requirements for all 10 RoHS substances, including the requirement that RoHS substance do not exceed 0.1% by weight in homogeneous materials. Where designed to be soldered at high temperatures, "RoHS" products are suitable for use in specified lead-free processes. TI may reference these types of products as "Pb-Free".

**RoHS Exempt:** TI defines "RoHS Exempt" to mean products that contain lead but are compliant with EU RoHS pursuant to a specific EU RoHS exemption.

**Green:** TI defines "Green" to mean the content of Chlorine (Cl) and Bromine (Br) based flame retardants meet JS709B low halogen requirements of <=1000ppm threshold. Antimony trioxide based flame retardants must also meet the <=1000ppm threshold requirement.

(3) MSL, Peak Temp. - The Moisture Sensitivity Level rating according to the JEDEC industry standard classifications, and peak solder temperature.

(4) There may be additional marking, which relates to the logo, the lot trace code information, or the environmental category on the device.

(5) Multiple Device Markings will be inside parentheses. Only one Device Marking contained in parentheses and separated by a "~" will appear on a device. If a line is indented then it is a continuation of the previous line and the two combined represent the entire Device Marking for that device.

(6) Lead finish/Ball material - Orderable Devices may have multiple material finish options. Finish options are separated by a vertical ruled line. Lead finish/Ball material values may wrap to two lines if the finish value exceeds the maximum column width.

**Important Information and Disclaimer:**The information provided on this page represents TI's knowledge and belief as of the date that it is provided. TI bases its knowledge and belief on information provided by third parties, and makes no representation or warranty as to the accuracy of such information. Efforts are underway to better integrate information from third parties. TI has taken and continues to take reasonable steps to provide representative and accurate information but may not have conducted destructive testing or chemical analysis on incoming materials and chemicals. TI and TI suppliers consider certain information to be proprietary, and thus CAS numbers and other limited information may not be available for release.

In no event shall TI's liability arising out of such information exceed the total purchase price of the TI part(s) at issue in this document sold by TI to Customer on an annual basis.

**OTHER QUALIFIED VERSIONS OF MCT8316Z :**

- Automotive : [MCT8316Z-Q1](#)

## NOTE: Qualified Version Definitions:

- Automotive - Q100 devices qualified for high-reliability automotive applications targeting zero defects

## TAPE AND REEL INFORMATION

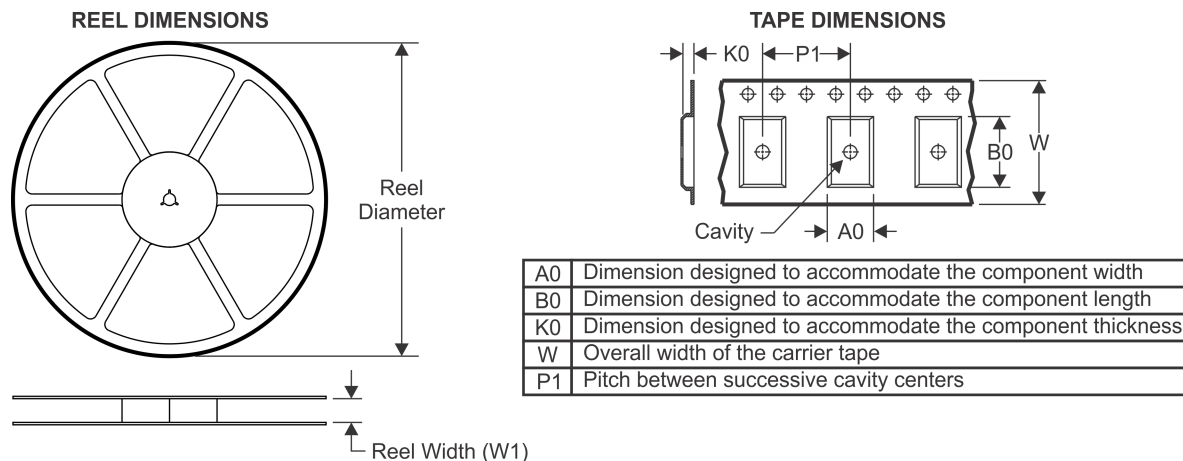

### QUADRANT ASSIGNMENTS FOR PIN 1 ORIENTATION IN TAPE

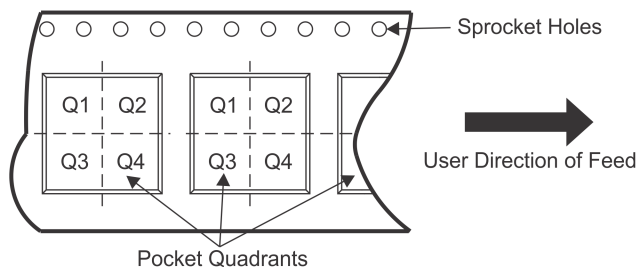

\*All dimensions are nominal

Device	Package Type	Package Drawing	Pins	SPQ	Reel Diameter (mm)	Reel Width W1 (mm)	A0 (mm)	B0 (mm)	K0 (mm)	P1 (mm)	W (mm)	Pin1 Quadrant
MCT8316Z0RRGFR	VQFN	RGF	40	3000	330.0	16.4	5.25	7.25	1.45	8.0	16.0	Q1
MCT8316Z0TRGFR	VQFN	RGF	40	3000	330.0	16.4	5.25	7.25	1.45	8.0	16.0	Q1

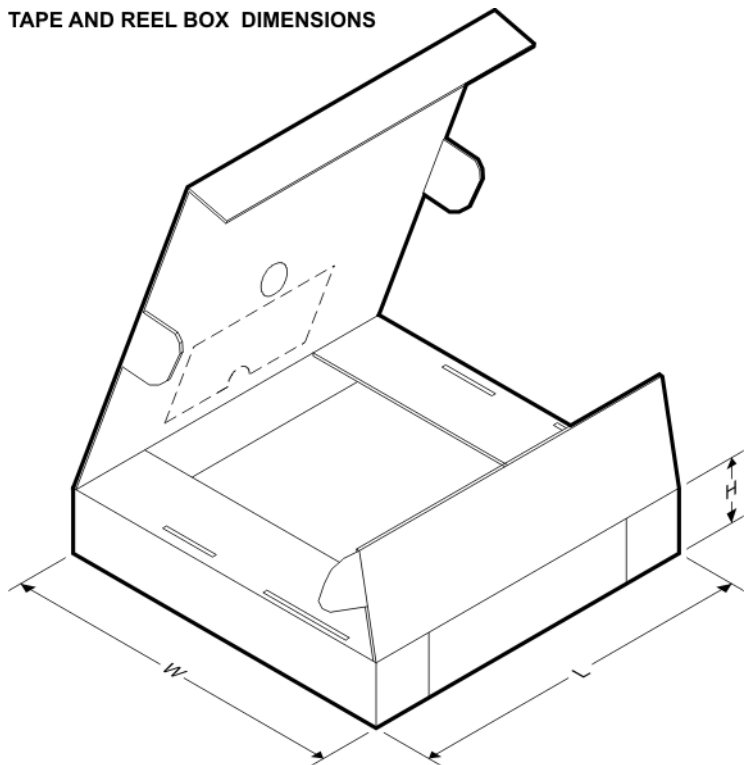
**TAPE AND REEL BOX DIMENSIONS**

\*All dimensions are nominal

Device	Package Type	Package Drawing	Pins	SPQ	Length (mm)	Width (mm)	Height (mm)
MCT8316Z0RRGFR	VQFN	RGF	40	3000	367.0	367.0	35.0
MCT8316Z0TRGFR	VQFN	RGF	40	3000	367.0	367.0	35.0

## GENERIC PACKAGE VIEW

**RGF 40**

**VQFN - 1 mm max height**

5 x 7, 0.5 mm pitch

PLASTIC QUAD FLAT PACK- NO LEAD

This image is a representation of the package family, actual package may vary.  
Refer to the product data sheet for package details.

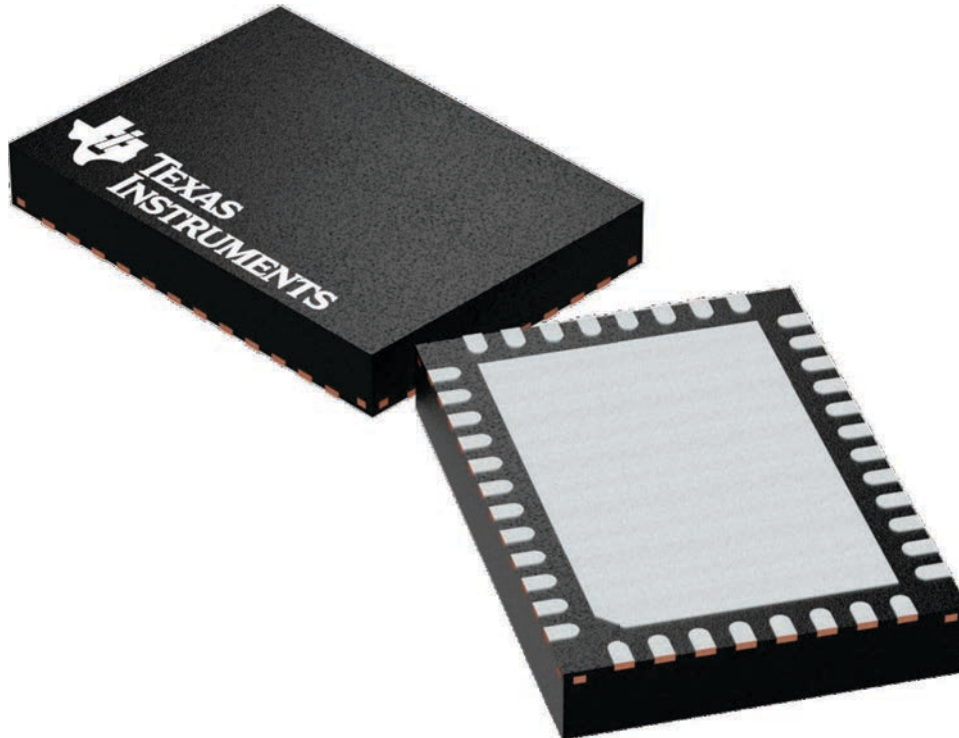

4225115/A

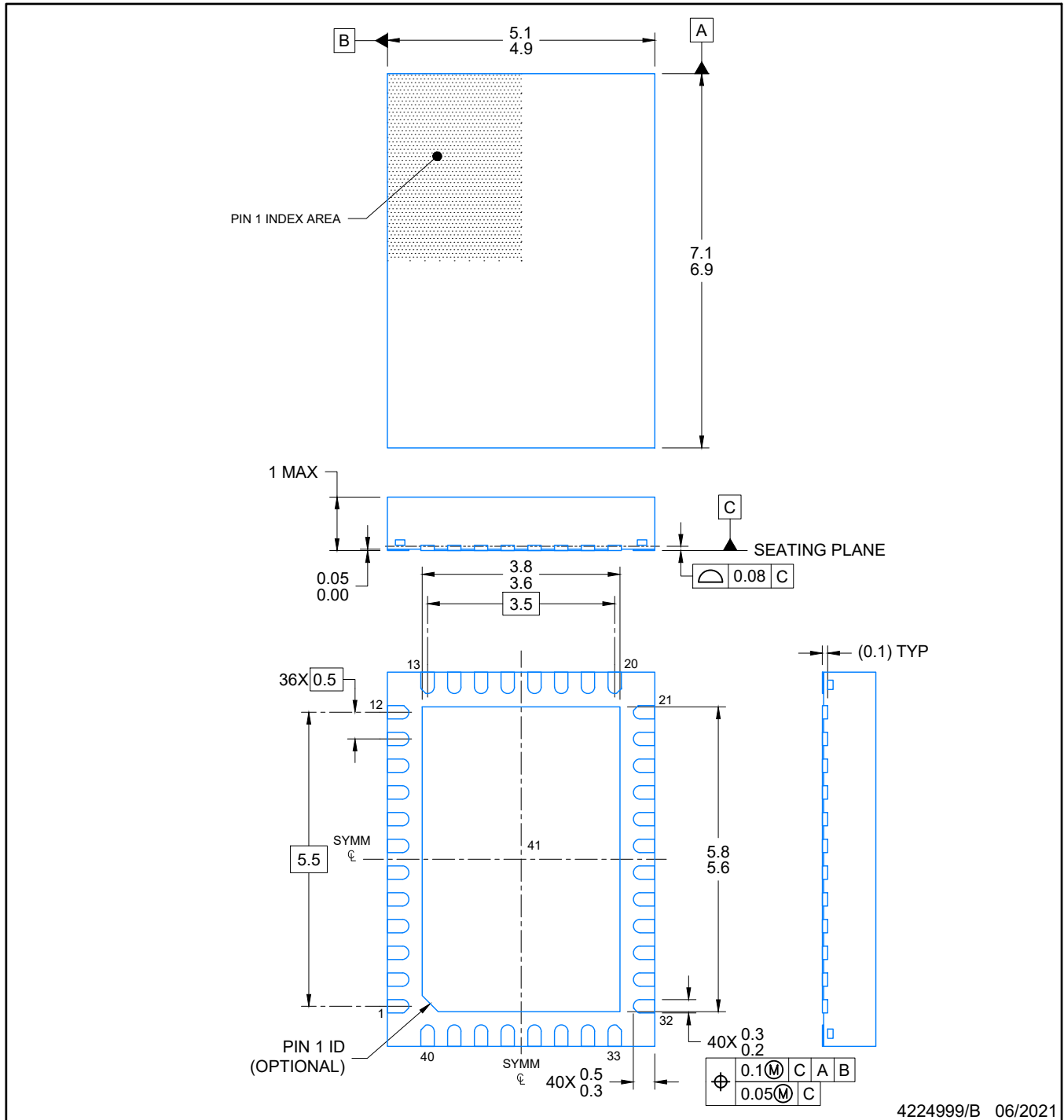

4224999/B 06/2021

NOTES:

1. All linear dimensions are in millimeters. Any dimensions in parenthesis are for reference only. Dimensioning and tolerancing per ASME Y14.5M.
2. This drawing is subject to change without notice.
3. The package thermal pad must be soldered to the printed circuit board for optimal thermal and mechanical performance.

# EXAMPLE BOARD LAYOUT

RGF0040E

VQFN - 1 mm max height

PLASTIC QUAD FLAT PACK- NO LEAD

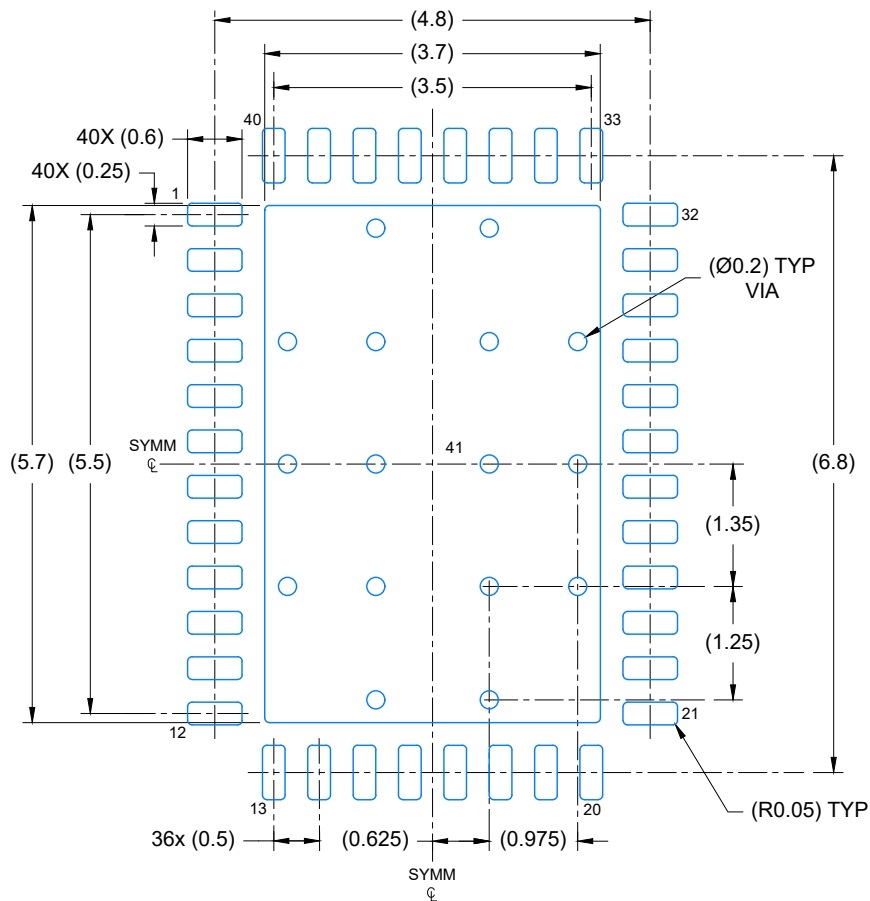

LAND PATTERN EXAMPLE  
EXPOSED METAL SHOWN  
SCALE: 12X

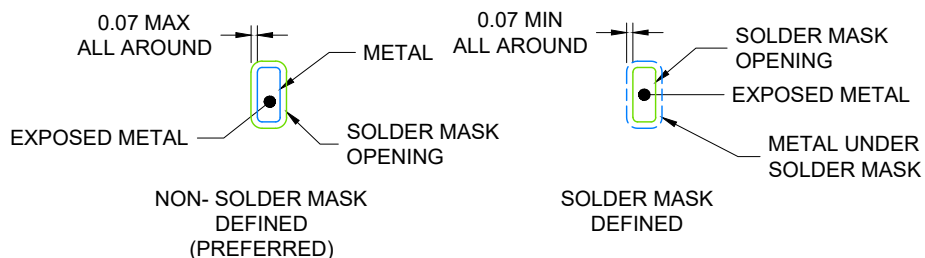

SOLDER MASK DETAILS

4224999/B 06/2021

NOTES: (continued)

4. This package is designed to be soldered to a thermal pad on the board. For more information, see Texas Instruments literature number SLUA271 ([www.ti.com/lit/slua271](http://www.ti.com/lit/slua271)).
5. Vias are optional depending on application, refer to device data sheet. If any vias are implemented, refer to their locations shown on this view. It is recommended that vias under paste be filled, plugged or tented.

# EXAMPLE STENCIL DESIGN

RGF0040E

VQFN - 1 mm max height

PLASTIC QUAD FLAT PACK- NO LEAD

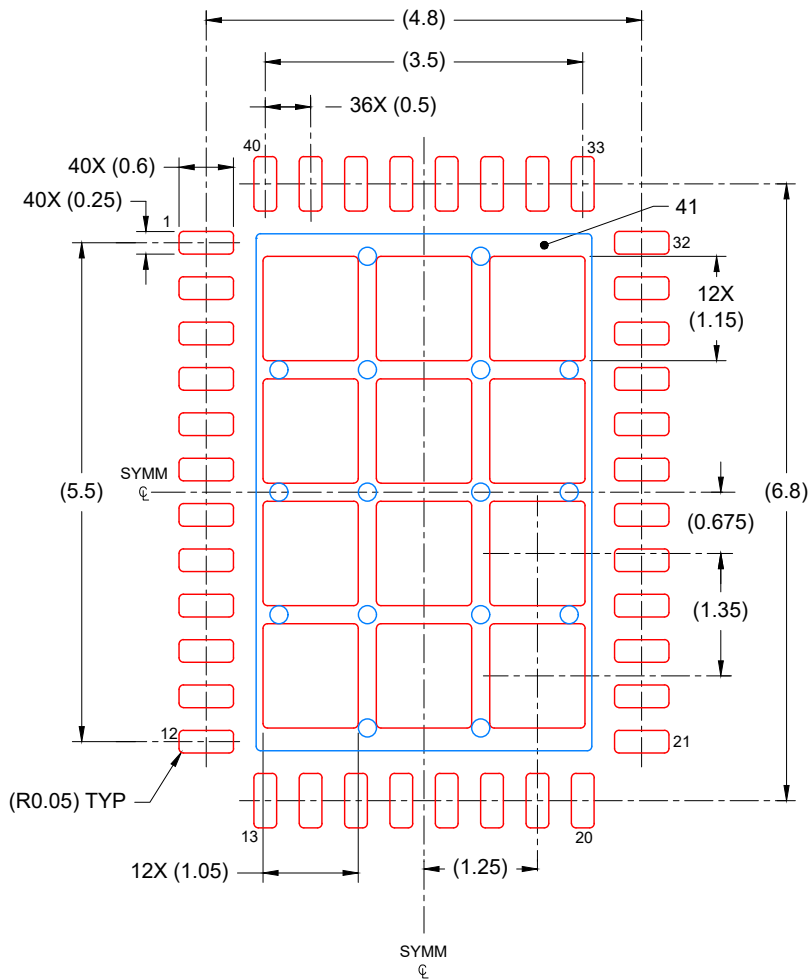

SOLDER PASTE EXAMPLE  
BASED ON 0.125 mm THICK STENCIL

EXPOSED PAD  
69% PRINTED COVERAGE BY AREA  
SCALE: 12X

4224999/B 06/2021

NOTES: (continued)

6. Laser cutting apertures with trapezoidal walls and rounded corners may offer better paste release. IPC-7525 may have alternate design recommendations.

## 重要声明和免责声明

TI“按原样”提供技术和可靠性数据（包括数据表）、设计资源（包括参考设计）、应用或其他设计建议、网络工具、安全信息和其他资源，不保证没有瑕疵且不做任何明示或暗示的担保，包括但不限于对适销性、某特定用途方面的适用性或不侵犯任何第三方知识产权的暗示担保。

这些资源可供使用 TI 产品进行设计的熟练开发人员使用。您将自行承担以下全部责任：(1) 针对您的应用选择合适的 TI 产品，(2) 设计、验证并测试您的应用，(3) 确保您的应用满足相应标准以及任何其他功能安全、信息安全、监管或其他要求。

这些资源如有变更，恕不另行通知。TI 授权您仅可将这些资源用于研发本资源所述的 TI 产品的应用。严禁对这些资源进行其他复制或展示。您无权使用任何其他 TI 知识产权或任何第三方知识产权。您应全额赔偿因在这些资源的使用中对 TI 及其代表造成的任何索赔、损害、成本、损失和债务，TI 对此概不负责。

TI 提供的产品受 [TI 的销售条款](#) 或 [ti.com](#) 上其他适用条款/TI 产品随附的其他适用条款的约束。TI 提供这些资源并不会扩展或以其他方式更改 TI 针对 TI 产品发布的适用的担保或担保免责声明。

TI 反对并拒绝您可能提出的任何其他或不同的条款。

邮寄地址：Texas Instruments, Post Office Box 655303, Dallas, Texas 75265

Copyright © 2022，德州仪器 (TI) 公司