

## TPS7A4001-EP 100V 输入电压、50mA 超高电压线性稳压器

### 1 特性

- 超高最大输入电压：100V
- 宽输入电压范围：7V 至 100V
- 准确度：
  - 标称：1%
  - 整个线路、负载和温度范围内：2.7%
- 低静态电流：25 $\mu$ A
- 关断时的静态电流：4.1 $\mu$ A
- 最大输出电流：50mA
- CMOS 逻辑电平兼容的使能引脚
- 可调节输出电压范围约为 1.175V 至 90V
- 与陶瓷电容搭配使用时可保持稳定：
  - 输入电容： $\geq 1\mu$ F
  - 输出电容： $\geq 4.7\mu$ F
- 压降电压：290mV
- 内置限流和热关断保护
- 封装：高散热性能 HVSSOP 封装 PowerPAD™
- 支持国防、航天和医疗应用
  - 受控基线
  - 同一组装和测试场所
  - 同一制造场所
  - 支持军用（-55°C 至 125°C）温度范围
  - 延长的产品生命周期
  - 延长的产品变更通知
  - 产品可追溯性

### 2 应用

- 由工业用总线（具有高电压瞬态）供电的微处理器、微控制器
- 工业自动化
- 电信基础设施
- 车用
- 以太网供电 (PoE)
- 发光二极管 (LED) 照明
- 偏置电源

### 3 说明

TPS7A4001-EP 器件是一款能够耐受超高电压的线性稳压器，不仅融合了耐热增强型封装 (HVSSOP) 的优势，还能够承受持续直流电压或最高达 100V 的瞬态输入电压。

TPS7A4001-EP 器件与任何高于 4.7 $\mu$ F 的输出电容以及高于 1 $\mu$ F 的输入电容搭配使用时均可保持稳定（过热和浪涌保护）。鉴于这款器件的封装 (HVSSOP) 小巧且可能使用的输出电容也较小，因此实现起来只需占用非常小的电路板空间。此外，TPS7A4001-EP 器件还提供了一个与标准 CMOS 逻辑兼容的使能引脚 (EN)，用以使能低电流关断模式。

TPS7A4001-EP 器件内部具有热关断和电流限制功能，可在故障情况下保护系统。TPS7A4001-EP 器件的工作温度范围为  $T_J = -55^\circ\text{C}$  至  $125^\circ\text{C}$ 。

此外，TPS7A4001-EP 器件非常适合在电信和工业应用中利用中间电压轨生成低压电源；该器件不但能够提供一个经充分稳压的电压轨，而且能够承受超高的快速电压瞬变并在其间保持稳压状态。这些特性相当于一套更为简单且经济高效的电气浪涌保护电路，因此被包括 PoE、偏置电源和 LED 照明在内的多类应用广泛使用。

典型应用电路原理图

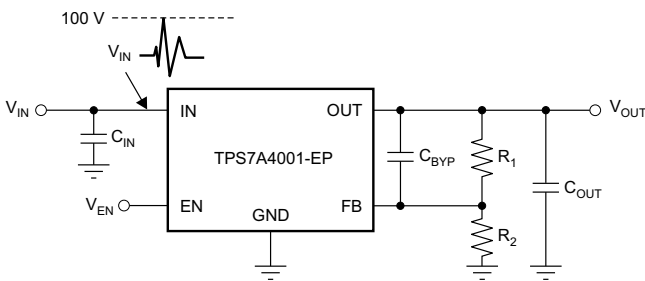

器件信息<sup>(1)</sup>

器件型号	封装	封装尺寸 (标称值)
TPS7A4001-EP	HVSSOP (8)	3.00mm x 5.00mm

(1) 要了解所有可用封装，请见数据表末尾的可订购产品附录。



## 目录

<p>1 特性 ..... 1</p> <p>2 应用 ..... 1</p> <p>3 说明 ..... 1</p> <p>4 修订历史记录 ..... 2</p> <p>5 <b>Pin Configuration and Functions</b> ..... 3</p> <p>6 <b>Specifications</b> ..... 4</p> <p>    6.1 Absolute Maximum Ratings ..... 4</p> <p>    6.2 ESD Ratings ..... 4</p> <p>    6.3 Recommended Operating Conditions ..... 4</p> <p>    6.4 Thermal Information ..... 4</p> <p>    6.5 Electrical Characteristics ..... 5</p> <p>    6.6 Typical Characteristics ..... 6</p> <p>7 <b>Detailed Description</b> ..... 8</p> <p>    7.1 Overview ..... 8</p> <p>    7.2 Functional Block Diagram ..... 8</p> <p>    7.3 Feature Description ..... 8</p>	<p>    7.4 Device Functional Modes ..... 9</p> <p>8 <b>Application and Implementation</b> ..... 10</p> <p>    8.1 Application Information ..... 10</p> <p>    8.2 Typical Application ..... 11</p> <p>9 <b>Power Supply Recommendations</b> ..... 12</p> <p>10 <b>Layout</b> ..... 13</p> <p>    10.1 Layout Guidelines ..... 13</p> <p>    10.2 Layout Example ..... 13</p> <p>    10.3 Thermal Considerations ..... 13</p> <p>    10.4 Power Dissipation ..... 14</p> <p>11 <b>器件和文档支持</b> ..... 15</p> <p>    11.1 社区资源 ..... 15</p> <p>    11.2 商标 ..... 15</p> <p>    11.3 静电放电警告 ..... 15</p> <p>    11.4 Glossary ..... 15</p> <p>12 <b>机械、封装和可订购信息</b> ..... 15</p>
---	---

## 4 修订历史记录

日期	修订版本	注释
2015 年 8 月	*	首次发布。

## 5 Pin Configuration and Functions

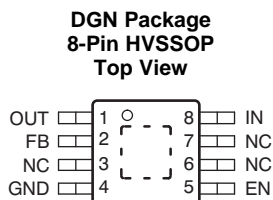

### Pin Functions

PIN		I/O	DESCRIPTION
NAME	NO.		
OUT	1	O	Regulator output. A capacitor >4.7 $\mu$ F must be tied from this pin to ground to assure stability.
FB	2	O	This pin is the input to the control-loop error amplifier. It is used to set the output voltage of the device.
NC	3	—	Not internally connected. This pin must either be left open or tied to GND.
	6		
	7		
GND	4	—	Ground
EN	5	I	This pin turns the regulator on or off. If $V_{EN} \geq V_{EN\_HI}$ the regulator is enabled. If $V_{EN} \leq V_{EN\_LO}$ , the regulator is disabled. If not used, the EN pin can be connected to IN. Make sure that $V_{EN} \leq V_{IN}$ at all times.
IN	8	I	Input supply
PowerPAD	—	—	Solder to printed-circuit-board (PCB) to enhance thermal performance. <b>NOTE: The PowerPAD is internally connected to GND.</b> Although it can be left floating, TI highly recommends connecting the PowerPAD to the GND plane.

## 6 Specifications

### 6.1 Absolute Maximum Ratings

 over operating junction temperature range (unless otherwise noted)<sup>(1)</sup>

		MIN	MAX	UNIT
Voltage	IN pin to GND pin	-0.3	102	V
	OUT pin to GND pin	-0.3	102	
	OUT pin to IN pin	-102	0.3	
	FB pin to GND pin	-0.3	2	
	FB pin to IN pin	-102	0.3	
	EN pin to IN pin	-102	0.3	
	EN pin to GND pin	-0.3	102	
Current	Peak output	Internally limited		
Temperature	Operating virtual junction, T <sub>J</sub>	-55	150	°C
	Storage, T <sub>stg</sub>	-65	150	

(1) Stresses beyond those listed under *Absolute Maximum Ratings* may cause permanent damage to the device. These are stress ratings only, which do not imply functional operation of the device at these or any other conditions beyond those indicated under *Recommended Operating Conditions*. Exposure to absolute-maximum-rated conditions for extended periods may affect device reliability.

### 6.2 ESD Ratings

		VALUE	UNIT
V <sub>(ESD)</sub>	Electrostatic discharge		V
	Human-body model (HBM), per ANSI/ESDA/JEDEC JS-001 <sup>(1)</sup>	±2500	
	Charged-device model (CDM), per JEDEC specification JESD22-C101 <sup>(2)</sup>	±500	

(1) JEDEC document JEP155 states that 500-V HBM allows safe manufacturing with a standard ESD control process.

(2) JEDEC document JEP157 states that 250-V CDM allows safe manufacturing with a standard ESD control process.

### 6.3 Recommended Operating Conditions

over operating junction temperature range (unless otherwise noted)

	MIN	NOM	MAX	UNIT
V <sub>IN</sub>	7		100	V
V <sub>OUT</sub>	1.161		90	V
V <sub>EN</sub>	0		100	V
I <sub>OUT</sub>	0		50	mA

### 6.4 Thermal Information

THERMAL METRIC <sup>(1)</sup>		TPS7A4001-EP	UNIT
		DGN (HVVSOP)	
		8 PINS	
R <sub>θJA</sub>	Junction-to-ambient thermal resistance	66.7	°C/W
R <sub>θJC(top)</sub>	Junction-to-case (top) thermal resistance	54.1	°C/W
R <sub>θJB</sub>	Junction-to-board thermal resistance	38.1	°C/W
Ψ <sub>JT</sub>	Junction-to-top characterization parameter	2	°C/W
Ψ <sub>JB</sub>	Junction-to-board characterization parameter	37.8	°C/W
R <sub>θJC(bot)</sub>	Junction-to-case (bottom) thermal resistance	15.5	°C/W

(1) For more information about traditional and new thermal metrics, see the *Semiconductor and IC Package Thermal Metrics* application report, [SPRA953](#).

## 6.5 Electrical Characteristics

At  $T_J = -55^\circ\text{C}$  to  $125^\circ\text{C}$ ,  $V_{IN} = V_{OUT(NOM)} + 2\text{ V}$  or  $V_{IN} = 7\text{ V}$  (whichever is greater),  $V_{EN} = V_{IN}$ ,  $I_{OUT} = 100\ \mu\text{A}$ ,  $C_{IN} = 1\ \mu\text{F}$ ,  $C_{OUT} = 4.7\ \mu\text{F}$ , and FB tied to OUT, unless otherwise noted.

PARAMETER		TEST CONDITIONS	MIN	TYP	MAX	UNIT
$V_{IN}$	Input voltage		7		100	V
$V_{REF}$	Internal reference	$T_J = 25^\circ\text{C}$ , $V_{FB} = V_{REF}$ , $V_{IN} = 9\text{ V}$ , $I_{OUT} = 25\text{ mA}$	1.161	1.173	1.185	V
$V_{OUT}$	Output voltage range <sup>(1)</sup>	$V_{IN} \geq V_{OUT(NOM)} + 2\text{ V}$	$V_{REF}$		90	V
	Nominal accuracy	$T_J = 25^\circ\text{C}$ , $V_{IN} = 9\text{ V}$ , $I_{OUT} = 25\text{ mA}$	-1		1	% $V_{OUT}$
	Overall accuracy	$V_{OUT(NOM)} + 2\text{ V} \leq V_{IN} \leq 24\text{ V}$ <sup>(2)</sup> $100\ \mu\text{A} \leq I_{OUT} \leq 50\text{ mA}$	-2.7		2.7	% $V_{OUT}$
$\frac{\Delta\%V_{OUT}}{\Delta V_{IN}}$	Line regulation	$7\text{ V} \leq V_{IN} \leq 100\text{ V}$		0.03		% $V_{OUT}$
$\frac{\Delta\%V_{OUT}}{\Delta I_{OUT}}$	Load regulation	$100\ \mu\text{A} \leq I_{OUT} \leq 50\text{ mA}$		0.31		% $V_{OUT}$
$V_{DO}$	Dropout voltage	$V_{IN} = 17\text{ V}$ , $V_{OUT(NOM)} = 18\text{ V}$ , $I_{OUT} = 20\text{ mA}$		290		mV
		$V_{IN} = 17\text{ V}$ , $V_{OUT(NOM)} = 18\text{ V}$ , $I_{OUT} = 50\text{ mA}$		0.78	1.3	V
$I_{LIM}$	Current limit	$V_{OUT} = 90\% V_{OUT(NOM)}$ , $V_{IN} = 7\text{ V}$ , $T_J \leq 85^\circ\text{C}$	51	146	207	mA
		$V_{OUT} = 90\% V_{OUT(NOM)}$ , $V_{IN} = 9\text{ V}$	51	165	220	mA
$I_{GND}$	Ground current	$7\text{ V} \leq V_{IN} \leq 100\text{ V}$ , $I_{OUT} = 0\text{ mA}$		25	65	$\mu\text{A}$
		$I_{OUT} = 50\text{ mA}$		25		$\mu\text{A}$
$I_{SHDN}$	Shutdown supply current	$V_{EN} = 0.4\text{ V}$		4.1	20	$\mu\text{A}$
$I_{FB}$	Feedback current <sup>(3)</sup>		-0.1	0.01	0.1	$\mu\text{A}$
$I_{EN}$	Enable current	$7\text{ V} \leq V_{IN} \leq 100\text{ V}$ , $V_{IN} = V_{EN}$		0.02	1	$\mu\text{A}$
$V_{EN\_HI}$	Enable high-level voltage		1.5		$V_{IN}$	V
$V_{EN\_LO}$	Enable low-level voltage		0		0.4	V
$V_{NOISE}$	Output noise voltage	$V_{IN} = 12\text{ V}$ , $V_{OUT(NOM)} = V_{REF}$ , $C_{OUT} = 10\ \mu\text{F}$ , $BW = 10\text{ Hz to }100\text{ kHz}$		58		$\mu\text{V}_{RMS}$
		$V_{IN} = 12\text{ V}$ , $V_{OUT(NOM)} = 5\text{ V}$ , $C_{OUT} = 10\ \mu\text{F}$ , $C_{BYP}$ <sup>(4)</sup> = $10\text{ nF}$ , $BW = 10\text{ Hz to }100\text{ kHz}$		73		$\mu\text{V}_{RMS}$
PSRR	Power-supply rejection ratio	$V_{IN} = 12\text{ V}$ , $V_{OUT(NOM)} = 5\text{ V}$ , $C_{OUT} = 10\ \mu\text{F}$ , $C_{BYP}$ <sup>(4)</sup> = $10\text{ nF}$ , $f = 100\text{ Hz}$		65		dB
$T_{SD}$	Thermal shutdown temperature	Shutdown, temperature increasing		170		$^\circ\text{C}$
		Reset, temperature decreasing		150		$^\circ\text{C}$
$T_J$	Operating junction temperature		-55		125	$^\circ\text{C}$

- (1) To ensure stability at no-load conditions, a current from the feedback resistive network greater than or equal to  $10\ \mu\text{A}$  is required.
- (2) Maximum input voltage is limited to  $24\text{ V}$  because of the package power dissipation limitations at full load ( $P \approx (V_{IN} - V_{OUT}) \times I_{OUT} = (24\text{ V} - V_{REF}) \times 50\text{ mA} \approx 1.14\text{ W}$ ). The device is capable of sourcing a maximum current of  $50\text{ mA}$  at higher input voltages as long as the power dissipated is within the thermal limits of the package plus any external heatsinking.
- (3)  $I_{FB} > 0$  flows out of the device.
- (4)  $C_{BYP}$  refers to a bypass capacitor connected to the FB and OUT pins.

### 6.6 Typical Characteristics

At  $T_J = -55^\circ\text{C}$  to  $125^\circ\text{C}$ ,  $V_{IN} = V_{OUT(NOM)} + 2\text{ V}$  or  $V_{IN} = 9\text{ V}$  (whichever is greater),  $V_{EN} = V_{IN}$ ,  $I_{OUT} = 100\ \mu\text{A}$ ,  $C_{IN} = 1\ \mu\text{F}$ ,  $C_{OUT} = 4.7\ \mu\text{F}$ , and FB tied to OUT, unless otherwise noted.

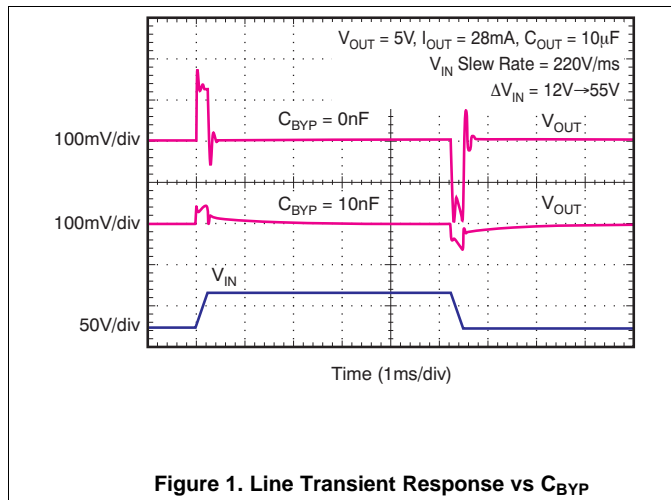

Figure 1. Line Transient Response vs  $C_{BYP}$

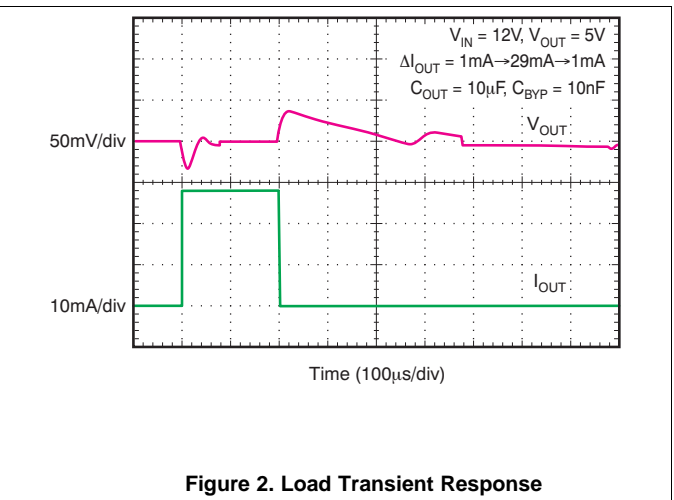

Figure 2. Load Transient Response

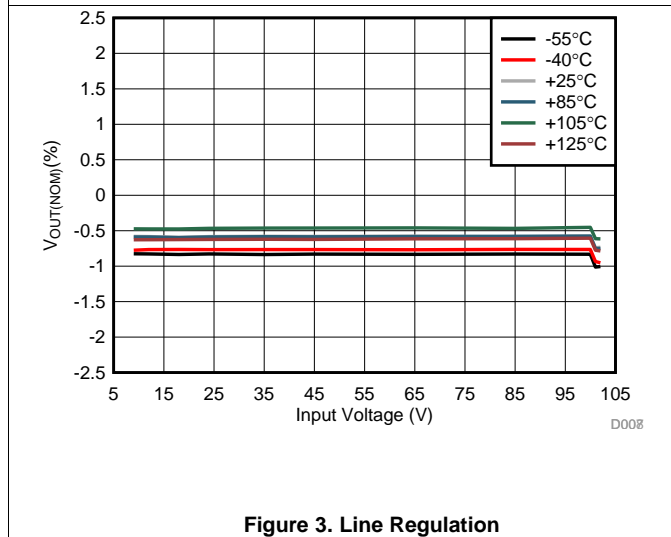

Figure 3. Line Regulation

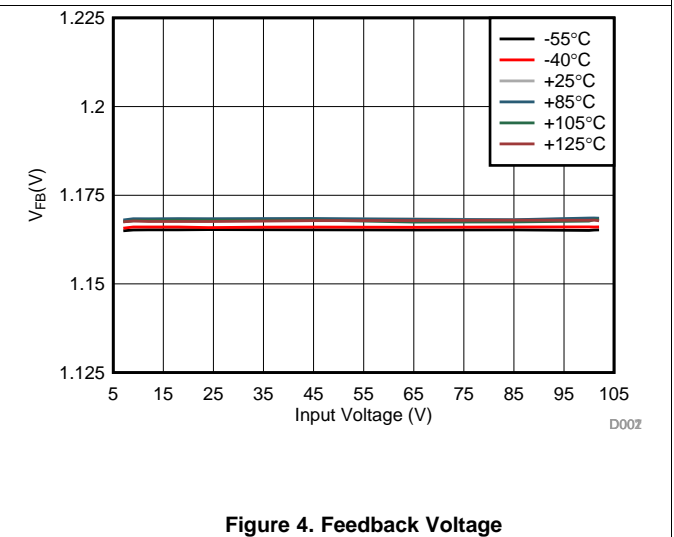

Figure 4. Feedback Voltage

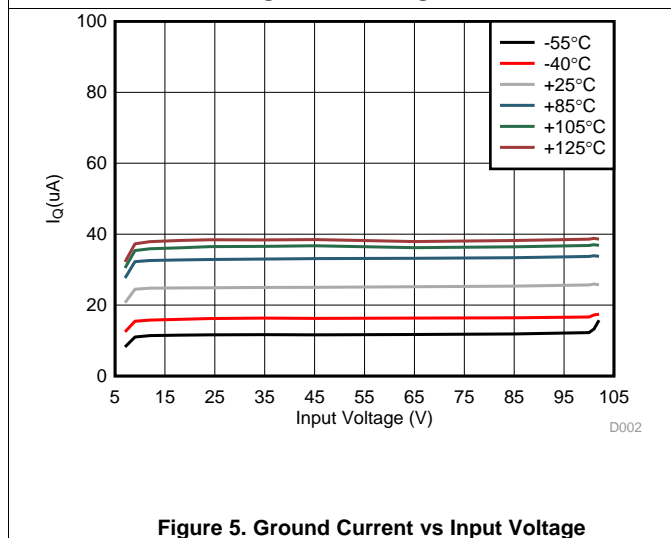

Figure 5. Ground Current vs Input Voltage

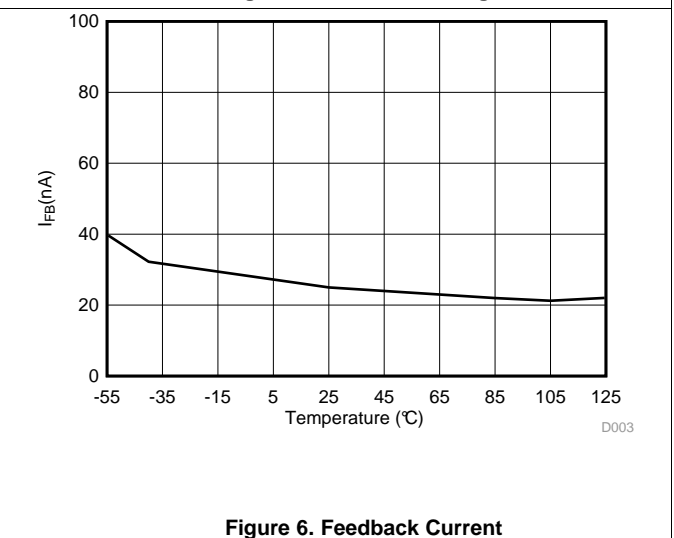

Figure 6. Feedback Current

Typical Characteristics (continued)

At  $T_J = -55^\circ\text{C}$  to  $125^\circ\text{C}$ ,  $V_{IN} = V_{OUT(NOM)} + 2\text{ V}$  or  $V_{IN} = 9\text{ V}$  (whichever is greater),  $V_{EN} = V_{IN}$ ,  $I_{OUT} = 100\ \mu\text{A}$ ,  $C_{IN} = 1\ \mu\text{F}$ ,  $C_{OUT} = 4.7\ \mu\text{F}$ , and FB tied to OUT, unless otherwise noted.

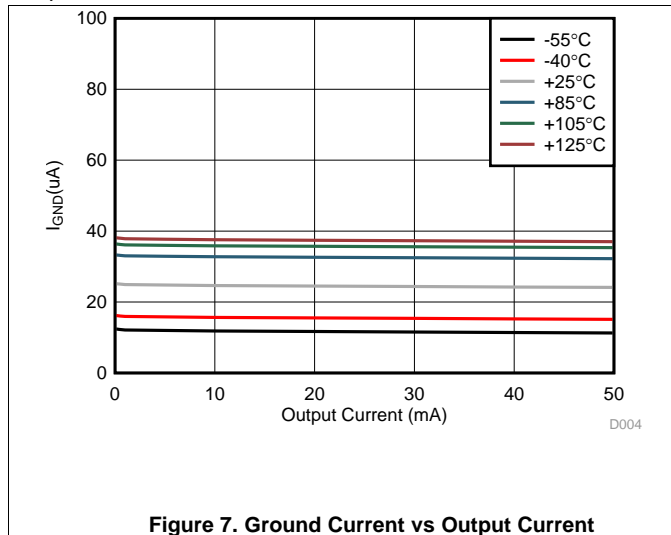

Figure 7. Ground Current vs Output Current

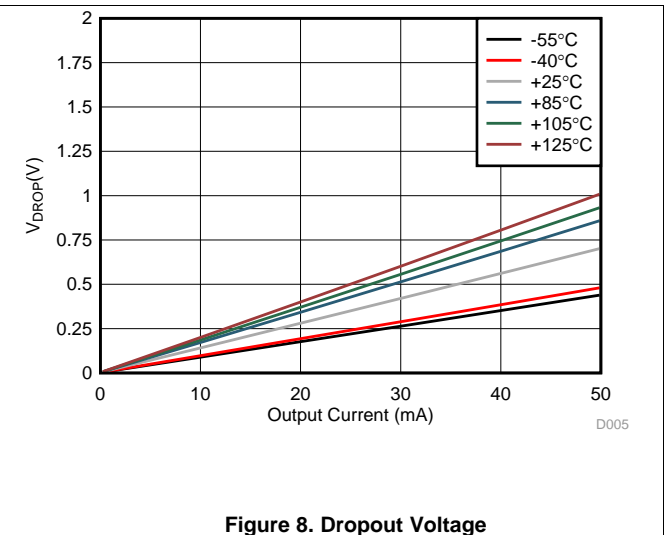

Figure 8. Dropout Voltage

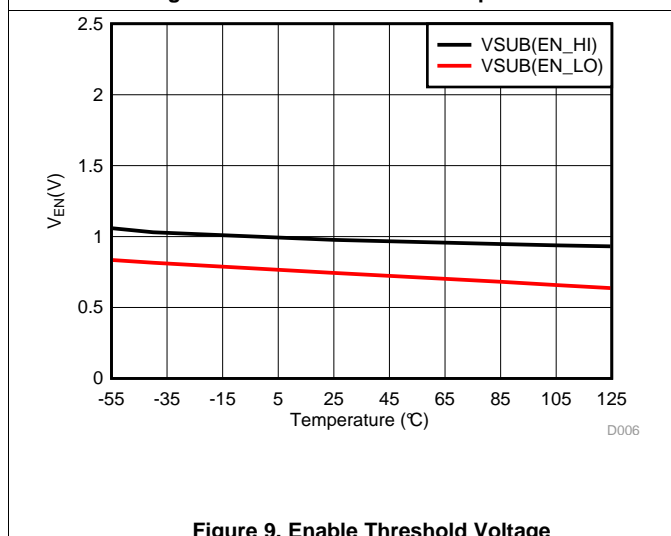

Figure 9. Enable Threshold Voltage

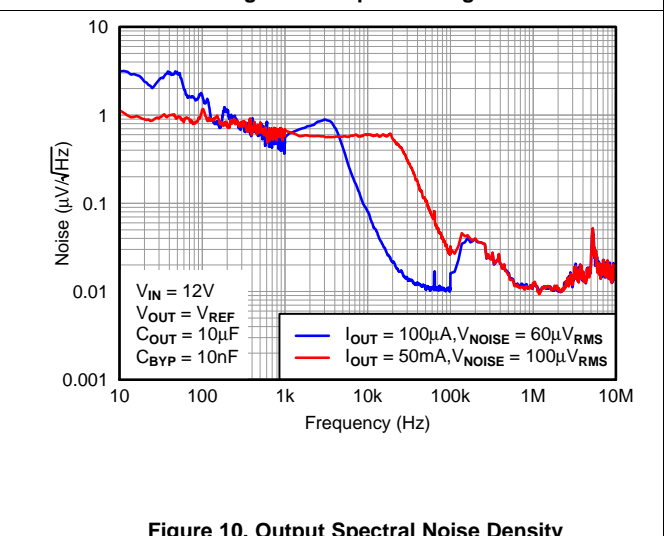

Figure 10. Output Spectral Noise Density

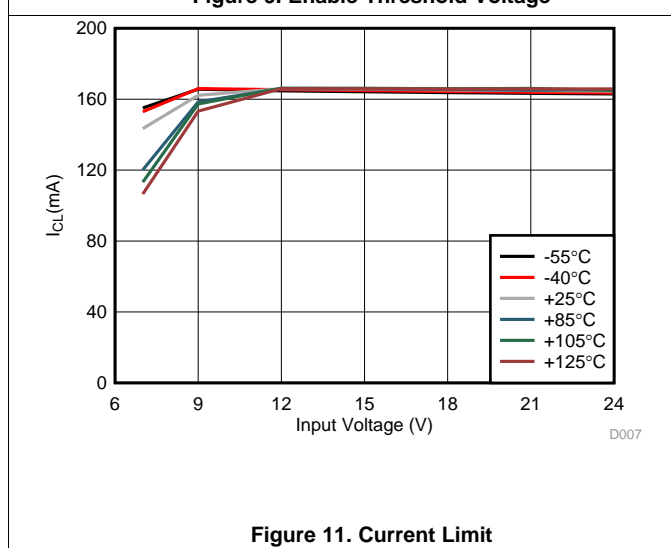

Figure 11. Current Limit

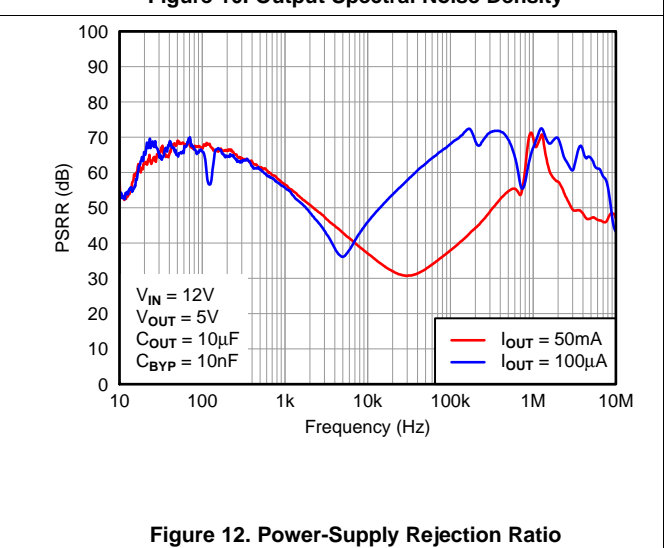

Figure 12. Power-Supply Rejection Ratio

## 7 Detailed Description

### 7.1 Overview

The TPS7A4001-EP device belongs to a new generation of linear regulators that use an innovative BiCMOS process technology to achieve very high maximum input and output voltages.

This process not only allows the TPS7A4001-EP device to maintain regulation during very fast high-voltage transients up to 105 V, but it also allows the TPS7A4001-EP device to regulate from a continuous high-voltage input rail. Unlike other regulators created using bipolar technology, the ground current of the TPS7A4001-EP device is also constant over its output current range, resulting in increased efficiency and lower power consumption.

These features, combined with a high thermal performance HVSSOP PowerPAD package, make this device ideal for industrial and telecom applications.

### 7.2 Functional Block Diagram

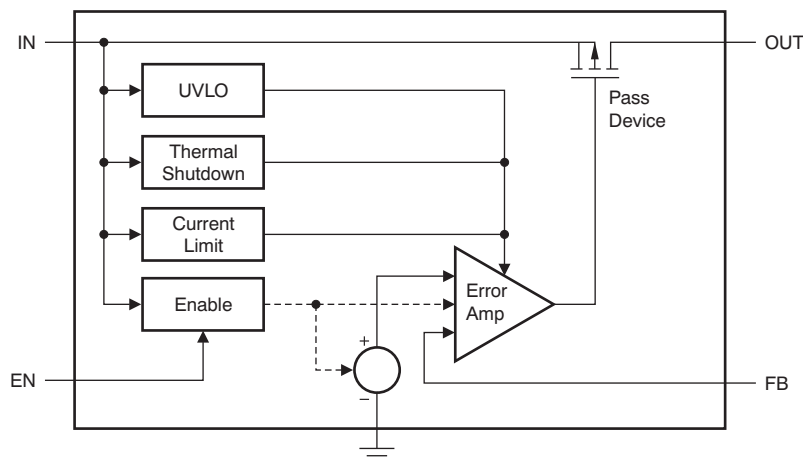

### 7.3 Feature Description

#### 7.3.1 Internal Current Limit

The fixed internal current limit of the TPS7A4001-EP device helps protect the regulator during fault conditions. The maximum amount of current the device can source is the current limit (309 mA, typical), and is largely independent of output voltage. For reliable operation, the device does not operate in current limit for extended periods of time.

#### 7.3.2 Enable Pin Operation

The TPS7A4001-EP device provides an enable pin (EN) feature that turns on the regulator when  $V_{EN} > V_{EN\_HI}$ , and disables the regulator when  $V_{EN} < V_{EN\_LO}$ .

#### 7.3.3 Thermal Protection

Thermal protection disables the output when the junction temperature rises to approximately 170°C, allowing the device to cool. When the junction temperature cools to approximately 150°C, the output circuitry is enabled. Depending on power dissipation, thermal resistance, and ambient temperature, the thermal protection circuit may cycle on and off. This cycling limits the dissipation of the regulator, protecting it from damage as a result of overheating.

Any tendency to activate the thermal protection circuit indicates excessive power dissipation or an inadequate heatsink. For reliable operation, limit junction temperature to a maximum of 125°C. To estimate the margin of safety in a complete design (including heatsink), increase the ambient temperature until the thermal protection is triggered; use worst-case loads and signal conditions. For good reliability, trigger thermal protection at least 35°C above the maximum expected ambient condition of your particular application. This configuration produces a worst-case junction temperature of 125°C at the highest expected ambient temperature and worst-case load.

## Feature Description (continued)

The internal protection circuitry of the TPS7A4001-EP device has been designed to protect against overload conditions. The protection circuitry was not intended to replace proper heatsinking. Continuously running the TPS7A4001-EP device into thermal shutdown degrades device reliability.

### 7.3.4 Undervoltage Lockout (UVLO)

The TPS7A4001-EP contains an UVLO comparator that ensures the error amplifier is disabled when the input voltage is below the required minimum operational voltage. The minimum recommended operational voltage is 7 V.

## 7.4 Device Functional Modes

### 7.4.1 Normal Operation

The device regulates to the nominal output voltage under the following conditions:

- The input voltage is at least as high as  $V_{IN(min)}$ .
- The input voltage is greater than the nominal output voltage added to the dropout voltage.
- The enable voltage has previously exceeded the enable rising threshold voltage and has not decreased below the enable falling threshold.
- The output current is less than the current limit.
- The device junction temperature is less than the maximum specified junction temperature.

### 7.4.2 Dropout Operation

If the input voltage is lower than the nominal output voltage plus the specified dropout voltage, but all other conditions are met for normal operation, the device operates in dropout mode. In this mode of operation, the output voltage is the same as the input voltage minus the dropout voltage. The transient performance of the device is significantly degraded because the pass device (as a bipolar junction transistor, or BJT) is in saturation and no longer controls the current through the LDO. Line or load transients in dropout can result in large output voltage deviations.

### 7.4.3 Disabled

The device is disabled under the following conditions:

- The enable voltage is less than the enable falling threshold voltage or has not yet exceeded the enable rising threshold.
- The device junction temperature is greater than the thermal shutdown temperature.

[Table 1](#) lists the conditions that lead to the different modes of operation.

**Table 1. Device Functional Mode Comparison**

OPERATING MODE	PARAMETER			
	$V_{IN}$	$V_{EN}$	$I_{OUT}$	$T_J$
Normal mode	$V_{IN} > V_{OUT(nom)} + V_{DO}$ and $V_{IN} > V_{IN(min)}$	$V_{EN} > V_{EN\_HI}$	$I_{OUT} < I_{LIM}$	$T_J < 125^{\circ}C$
Dropout mode	$V_{IN(min)} < V_{IN} < V_{OUT(nom)} + V_{DO}$	$V_{EN} > V_{EN\_HI}$	—	$T_J < 125^{\circ}C$
Disabled mode (any true condition disables the device)	—	$V_{EN} < V_{EN\_LO}$	—	$T_J > 170^{\circ}C$

## 8 Application and Implementation

### NOTE

Information in the following applications sections is not part of the TI component specification, and TI does not warrant its accuracy or completeness. TI's customers are responsible for determining suitability of components for their purposes. Customers should validate and test their design implementation to confirm system functionality.

### 8.1 Application Information

One of the primary applications of the TPS7A4001-EP device is to provide transient voltage protection to sensitive circuitry that may be damaged in the presence of high-voltage spikes.

This transient voltage protection can be more cost-effective and compact compared to topologies that use a transient voltage suppression (TVS) block.

#### 8.1.1 Adjustable Operation

The TPS7A4001-EP device has an output voltage range of about 1.175 to 90 V. The nominal output voltage of the device is set by two external resistors, as shown in [Figure 13](#).

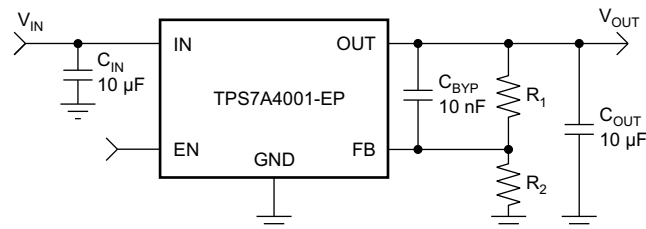

**Figure 13. Adjustable Operation for Maximum AC Performance**

Calculate  $R_1$  and  $R_2$  for any output voltage range using the formula shown in [Equation 1](#). To ensure stability under no-load conditions, this resistive network must provide a current  $\geq 10 \mu\text{A}$ .

$$R_1 = R_2 \left( \frac{V_{\text{OUT}}}{V_{\text{REF}}} - 1 \right), \quad \text{where } \frac{V_{\text{OUT}}}{R_1 + R_2} \geq 10 \mu\text{A} \quad (1)$$

If greater voltage accuracy is required, consider the output voltage offset contributions because of the feedback pin current and use 0.1% tolerance resistors.

## 8.2 Typical Application

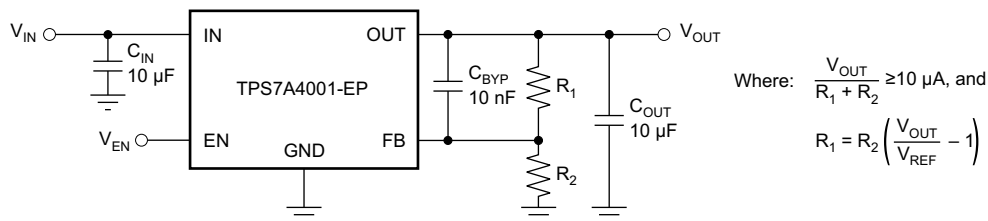

Figure 14. Example Circuit to Maximize Transient Performance

### 8.2.1 Design Requirements

For this design example, use the following parameters listed in Table 2.

Table 2. Design Parameters

PARAMETER	VALUE
$V_{IN}$	12 V, with 55 V surge tolerance
$V_{OUT}$	5 V (ideal), 4.981 (actual)
$I_{OUT}$	28 mA
Accuracy	5 %
R1, R2	162 k $\Omega$ , 49.9 k $\Omega$

### 8.2.2 Detailed Design Procedure

The maximum value of total feedback resistance can be calculated to be 500 k $\Omega$ . Equation 1 was used to calculate R1 and R2, and standard 1% resistors were selected to keep the accuracy within the 5% allocation. 10- $\mu\text{F}$  ceramic input and output capacitors were selected, along with a 10-nF bypass capacitor for optimal AC performance.

#### 8.2.2.1 Capacitor Recommendations

Low equivalent series resistance (ESR) capacitors should be used for the input, output, and bypass capacitors. Ceramic capacitors with X7R and X5R dielectrics are required. Ceramic X7R capacitors offer improved voltage and temperature coefficients, while ceramic X5R capacitors are the most cost-effective and are available in higher values.

#### NOTE

High ESR capacitors may degrade PSRR.

#### 8.2.2.2 Input and Output Capacitor Requirements

The TPS7A4001-EP device high voltage linear regulator achieves stability with a minimum output capacitance of 4.7  $\mu\text{F}$  and input capacitance of 1  $\mu\text{F}$ ; however, TI highly recommends to use 10- $\mu\text{F}$  output and input capacitors to maximize AC performance.

#### 8.2.2.3 Bypass Capacitor Requirements

Although a bypass capacitor ( $C_{BYP}$ ) is not needed to achieve stability, TI highly recommends using a 10-nF bypass capacitor to maximize AC performance (including line transient, noise, and PSRR). For additional information regarding the performance improvements of using a bypass capacitor, see .

#### 8.2.2.4 Transient Response

As with any regulator, increasing the size of the output capacitor reduces overshoot and undershoot magnitude but increases the duration of the transient response.

The presence of the  $C_{BYP}$  capacitor may greatly improve the line transient response of the TPS7A4001-EP device, as shown in Figure 1.

### 8.2.3 Application Curves

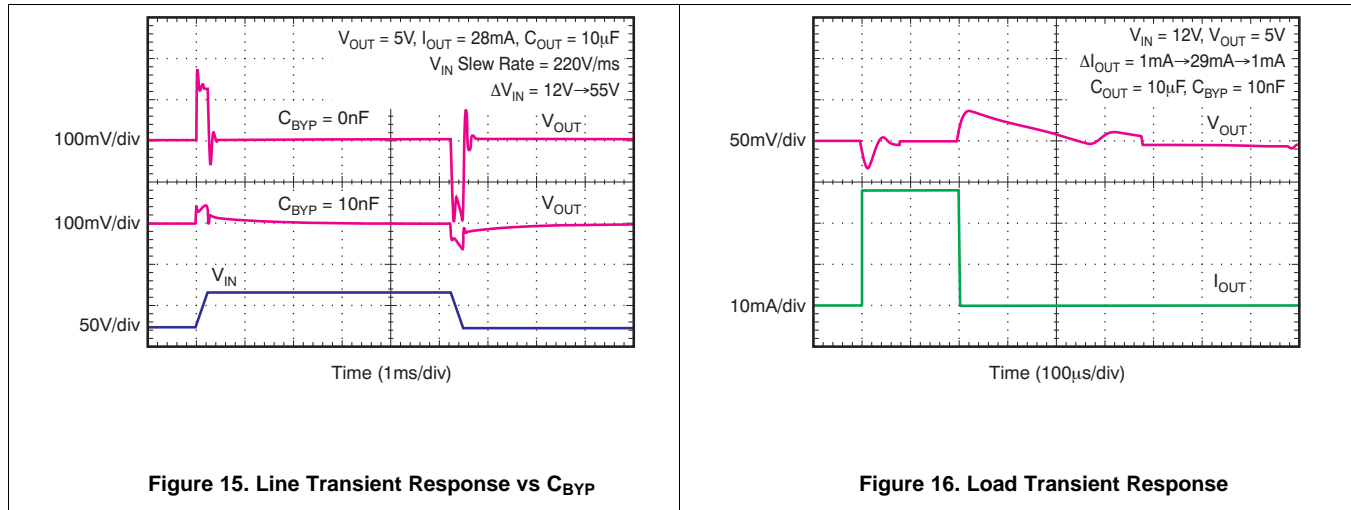

## 9 Power Supply Recommendations

The input supply for the LDO should not exceed its recommended operating conditions (7 V to 100 V). The input voltage should provide adequate headroom for the device to have a regulated output. If the input supply is noisy, additional input capacitors with low ESR can help improve the output noise performance. The input and output supplies should also be bypassed with 10- $\mu$ F capacitors located near the input and output pins. There should be no other components located between these capacitors and the pins.

## 10 Layout

### 10.1 Layout Guidelines

#### 10.1.1 Board Layout Recommendations to Improve PSRR and Noise Performance

To improve AC performance such as PSRR, output noise, and transient response, TI recommends designing the board with separate ground planes for IN and OUT, with each ground plane connected only at the GND pin of the device. In addition, the ground connection for the output capacitor should connect directly to the GND pin of the device.

Equivalent series inductance (ESL) and ESR must be minimized to maximize performance and ensure stability. Every capacitor ( $C_{IN}$ ,  $C_{OUT}$ ,  $C_{BYP}$ ) must be placed as close as possible to the device and on the same side of the PCB as the regulator itself.

Do not place any of the capacitors on the opposite side of the PCB from where the regulator is installed. The use of vias and long traces is strongly discouraged because they may impact system performance negatively and even cause instability.

If possible, and to ensure the maximum performance denoted in this product data sheet, use the same layout pattern used for the TPS7A40 evaluation board, available at [www.ti.com](http://www.ti.com).

### 10.2 Layout Example

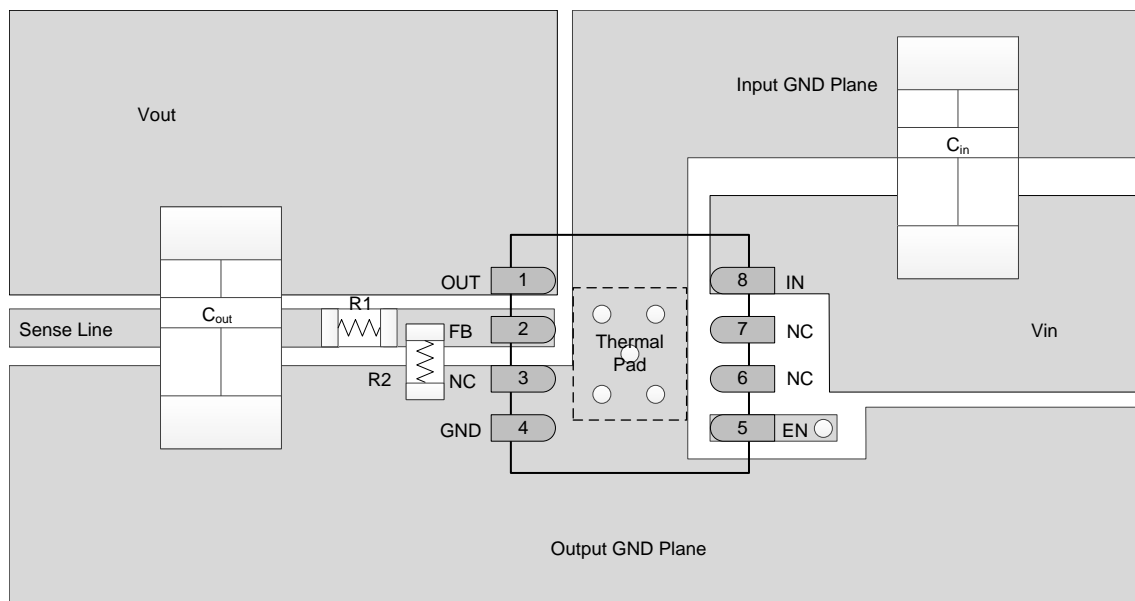

Figure 17. Recommended Layout Example

### 10.3 Thermal Considerations

Thermal protection disables the output when the junction temperature rises to approximately 170°C, allowing the device to cool. When the junction temperature cools to approximately 150°C, the output circuitry is enabled. Depending on power dissipation, thermal resistance, and ambient temperature, the thermal protection circuit may cycle ON and OFF. This cycling limits the dissipation of the regulator, protecting it from damage as a result of overheating.

## Thermal Considerations (接下页)

Any tendency to activate the thermal protection circuit indicates excessive power dissipation or an inadequate heatsink. For reliable operation, junction temperature should be limited to a maximum of 125°C. To estimate the margin of safety in a complete design (including heatsink), increase the ambient temperature until the thermal protection is triggered; use worst-case loads and signal conditions. For good reliability, thermal protection should trigger at least 45°C above the maximum expected ambient condition of the particular application. This configuration produces a worst-case junction temperature of 125°C at the highest expected ambient temperature and worst-case load.

The internal protection circuitry of the TPS7A4001-EP has been designed to protect against overload conditions. It was not intended to replace proper heatsinking. Continuously running the TPS7A4001-EP device into thermal shutdown degrades device reliability.

### 10.4 Power Dissipation

The ability to remove heat from the die is different for each package type, presenting different considerations in the PCB layout. The PCB area around the device that is free of other components moves the heat from the device to the ambient air. Using heavier copper increases the effectiveness in removing heat from the device. The addition of plated through-holes to heat dissipating layers also improves the heatsink effectiveness.

Power dissipation depends on input voltage and load conditions. Power dissipation ( $P_D$ ) is equal to the product of the output current times the voltage drop across the output pass element, as shown in [Equation 2](#):

$$P_D = (V_{IN} - V_{OUT}) I_{OUT} \quad (2)$$

## 11 器件和文档支持

### 11.1 社区资源

The following links connect to TI community resources. Linked contents are provided "AS IS" by the respective contributors. They do not constitute TI specifications and do not necessarily reflect TI's views; see TI's [Terms of Use](#).

**TI E2E™ Online Community** *TI's Engineer-to-Engineer (E2E) Community*. Created to foster collaboration among engineers. At [e2e.ti.com](http://e2e.ti.com), you can ask questions, share knowledge, explore ideas and help solve problems with fellow engineers.

**Design Support** *TI's Design Support* Quickly find helpful E2E forums along with design support tools and contact information for technical support.

### 11.2 商标

PowerPAD, E2E are trademarks of Texas Instruments.  
All other trademarks are the property of their respective owners.

### 11.3 静电放电警告



这些装置包含有限的内置 ESD 保护。存储或装卸时，应将导线一起截短或将装置放置于导电泡棉中，以防止 MOS 门极遭受静电损伤。

### 11.4 Glossary

[SLYZ022](#) — *TI Glossary*.

This glossary lists and explains terms, acronyms, and definitions.

## 12 机械、封装和可订购信息

以下页中包括机械、封装和可订购信息。 这些信息是针对指定器件可提供的最新数据。 这些数据会在无通知且不  
对本文档进行修订的情况下发生改变。 欲获得该数据表的浏览器版本，请查阅左侧的导航栏。

## 重要声明

德州仪器(TI)及其下属子公司有权根据 JESD46 最新标准,对所提供的产品和服务进行更正、修改、增强、改进或其它更改,并有权根据 JESD48 最新标准中止提供任何产品和服务。客户在下订单前应获取最新的相关信息,并验证这些信息是否完整且是最新的。所有产品的销售都遵循在订单确认时所提供的TI 销售条款与条件。

TI 保证其所销售的组件的性能符合产品销售时 TI 半导体产品销售条件与条款的适用规范。仅在 TI 保证的范围内,且 TI 认为有必要时才会使用测试或其它质量控制技术。除非适用法律做出了硬性规定,否则没有必要对每种组件的所有参数进行测试。

TI 对应用帮助或客户产品设计不承担任何义务。客户应对其使用 TI 组件的产品和应用自行负责。为尽量减小与客户产品和应用相关的风险,客户应提供充分的设计与操作安全措施。

TI 不对任何 TI 专利权、版权、屏蔽作品权或其它与使用了 TI 组件或服务的组合设备、机器或流程相关的 TI 知识产权中授予的直接或隐含权限作出任何保证或解释。TI 所发布的与第三方产品或服务有关的信息,不能构成从 TI 获得使用这些产品或服务的许可、授权、或认可。使用此类信息可能需要获得第三方的专利权或其它知识产权方面的许可,或是 TI 的专利权或其它知识产权方面的许可。

对于 TI 的产品手册或数据表中 TI 信息的重要部分,仅在没有对内容进行任何篡改且带有相关授权、条件、限制和声明的情况下才允许进行复制。TI 对此类篡改过的文件不承担任何责任或义务。复制第三方的信息可能需要服从额外的限制条件。

在转售 TI 组件或服务时,如果对该组件或服务参数的陈述与 TI 标明的参数相比存在差异或虚假成分,则会失去相关 TI 组件或服务的所有明示或暗示授权,且这是不正当的、欺诈性商业行为。TI 对任何此类虚假陈述均不承担任何责任或义务。

客户认可并同意,尽管任何应用相关信息或支持仍可能由 TI 提供,但他们将独立负责满足与其产品及其在应用中使用的 TI 产品相关的所有法律、法规和安全相关要求。客户声明并同意,他们具备制定与实施安全措施所需的全部专业技术和知识,可预见故障的危险后果、监测故障及其后果、降低有可能造成人身伤害的故障的发生机率并采取适当的补救措施。客户将全额赔偿因在此类安全关键应用中使用任何 TI 组件而对 TI 及其代理造成的任何损失。

在某些场合中,为了推进安全相关应用有可能对 TI 组件进行特别的促销。TI 的目标是利用此类组件帮助客户设计和创立其特有的可满足适用的功能安全性标准和要求的终端产品解决方案。尽管如此,此类组件仍然服从这些条款。

TI 组件未获得用于 FDA Class III (或类似的生命攸关医疗设备)的授权许可,除非各方授权官员已经达成了专门管控此类使用的特别协议。

只有那些 TI 特别注明属于军用等级或“增强型塑料”的 TI 组件才是设计或专门用于军事/航空应用或环境的。购买者认可并同意,对并非指定面向军事或航空航天用途的 TI 组件进行军事或航空航天方面的应用,其风险由客户单独承担,并且由客户独立负责满足与此类使用相关的所有法律和法规要求。

TI 已明确指定符合 ISO/TS16949 要求的产品,这些产品主要用于汽车。在任何情况下,因使用非指定产品而无法达到 ISO/TS16949 要求, TI 不承担任何责任。

	产品		应用
数字音频	<a href="http://www.ti.com.cn/audio">www.ti.com.cn/audio</a>	通信与电信	<a href="http://www.ti.com.cn/telecom">www.ti.com.cn/telecom</a>
放大器和线性器件	<a href="http://www.ti.com.cn/amplifiers">www.ti.com.cn/amplifiers</a>	计算机及周边	<a href="http://www.ti.com.cn/computer">www.ti.com.cn/computer</a>
数据转换器	<a href="http://www.ti.com.cn/dataconverters">www.ti.com.cn/dataconverters</a>	消费电子	<a href="http://www.ti.com.cn/consumer-apps">www.ti.com.cn/consumer-apps</a>
DLP® 产品	<a href="http://www.dlp.com">www.dlp.com</a>	能源	<a href="http://www.ti.com.cn/energy">www.ti.com.cn/energy</a>
DSP - 数字信号处理器	<a href="http://www.ti.com.cn/dsp">www.ti.com.cn/dsp</a>	工业应用	<a href="http://www.ti.com.cn/industrial">www.ti.com.cn/industrial</a>
时钟和计时器	<a href="http://www.ti.com.cn/clockandtimers">www.ti.com.cn/clockandtimers</a>	医疗电子	<a href="http://www.ti.com.cn/medical">www.ti.com.cn/medical</a>
接口	<a href="http://www.ti.com.cn/interface">www.ti.com.cn/interface</a>	安防应用	<a href="http://www.ti.com.cn/security">www.ti.com.cn/security</a>
逻辑	<a href="http://www.ti.com.cn/logic">www.ti.com.cn/logic</a>	汽车电子	<a href="http://www.ti.com.cn/automotive">www.ti.com.cn/automotive</a>
电源管理	<a href="http://www.ti.com.cn/power">www.ti.com.cn/power</a>	视频和影像	<a href="http://www.ti.com.cn/video">www.ti.com.cn/video</a>
微控制器 (MCU)	<a href="http://www.ti.com.cn/microcontrollers">www.ti.com.cn/microcontrollers</a>		
RFID 系统	<a href="http://www.ti.com.cn/rfidsys">www.ti.com.cn/rfidsys</a>		
OMAP应用处理器	<a href="http://www.ti.com/omap">www.ti.com/omap</a>		
无线连通性	<a href="http://www.ti.com.cn/wirelessconnectivity">www.ti.com.cn/wirelessconnectivity</a>	德州仪器在线技术支持社区	<a href="http://www.deyisupport.com">www.deyisupport.com</a>

邮寄地址: 上海市浦东新区世纪大道1568号, 中建大厦32楼邮政编码: 200122  
Copyright © 2015, 德州仪器半导体技术(上海)有限公司

**PACKAGING INFORMATION**

Orderable Device	Status (1)	Package Type	Package Drawing	Pins	Package Qty	Eco Plan (2)	Lead finish/ Ball material (6)	MSL Peak Temp (3)	Op Temp (°C)	Device Marking (4/5)	Samples
TPS7A4001MDGNREP	ACTIVE	HVSSOP	DGN	8	2500	RoHS & Green	NIPDAU	Level-2-260C-1 YEAR	-55 to 125	ZFY4	<a href="#">Samples</a>
V62/15603-01XE	ACTIVE	HVSSOP	DGN	8	2500	RoHS & Green	NIPDAU	Level-2-260C-1 YEAR	-55 to 125	ZFY4	<a href="#">Samples</a>

(1) The marketing status values are defined as follows:

**ACTIVE:** Product device recommended for new designs.

**LIFEBUY:** TI has announced that the device will be discontinued, and a lifetime-buy period is in effect.

**NRND:** Not recommended for new designs. Device is in production to support existing customers, but TI does not recommend using this part in a new design.

**PREVIEW:** Device has been announced but is not in production. Samples may or may not be available.

**OBSOLETE:** TI has discontinued the production of the device.

(2) **RoHS:** TI defines "RoHS" to mean semiconductor products that are compliant with the current EU RoHS requirements for all 10 RoHS substances, including the requirement that RoHS substance do not exceed 0.1% by weight in homogeneous materials. Where designed to be soldered at high temperatures, "RoHS" products are suitable for use in specified lead-free processes. TI may reference these types of products as "Pb-Free".

**RoHS Exempt:** TI defines "RoHS Exempt" to mean products that contain lead but are compliant with EU RoHS pursuant to a specific EU RoHS exemption.

**Green:** TI defines "Green" to mean the content of Chlorine (Cl) and Bromine (Br) based flame retardants meet JS709B low halogen requirements of <=1000ppm threshold. Antimony trioxide based flame retardants must also meet the <=1000ppm threshold requirement.

(3) MSL, Peak Temp. - The Moisture Sensitivity Level rating according to the JEDEC industry standard classifications, and peak solder temperature.

(4) There may be additional marking, which relates to the logo, the lot trace code information, or the environmental category on the device.

(5) Multiple Device Markings will be inside parentheses. Only one Device Marking contained in parentheses and separated by a "~" will appear on a device. If a line is indented then it is a continuation of the previous line and the two combined represent the entire Device Marking for that device.

(6) Lead finish/Ball material - Orderable Devices may have multiple material finish options. Finish options are separated by a vertical ruled line. Lead finish/Ball material values may wrap to two lines if the finish value exceeds the maximum column width.

**Important Information and Disclaimer:**The information provided on this page represents TI's knowledge and belief as of the date that it is provided. TI bases its knowledge and belief on information provided by third parties, and makes no representation or warranty as to the accuracy of such information. Efforts are underway to better integrate information from third parties. TI has taken and continues to take reasonable steps to provide representative and accurate information but may not have conducted destructive testing or chemical analysis on incoming materials and chemicals. TI and TI suppliers consider certain information to be proprietary, and thus CAS numbers and other limited information may not be available for release.

In no event shall TI's liability arising out of such information exceed the total purchase price of the TI part(s) at issue in this document sold by TI to Customer on an annual basis.



## GENERIC PACKAGE VIEW

**DGN 8**

**PowerPAD VSSOP - 1.1 mm max height**

3 x 3, 0.65 mm pitch

SMALL OUTLINE PACKAGE

This image is a representation of the package family, actual package may vary.  
Refer to the product data sheet for package details.

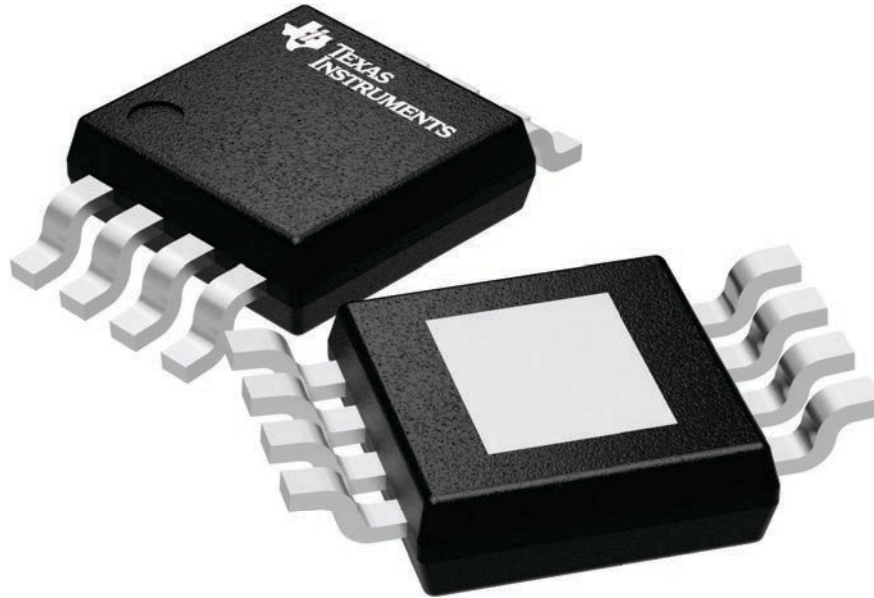

4225482/A

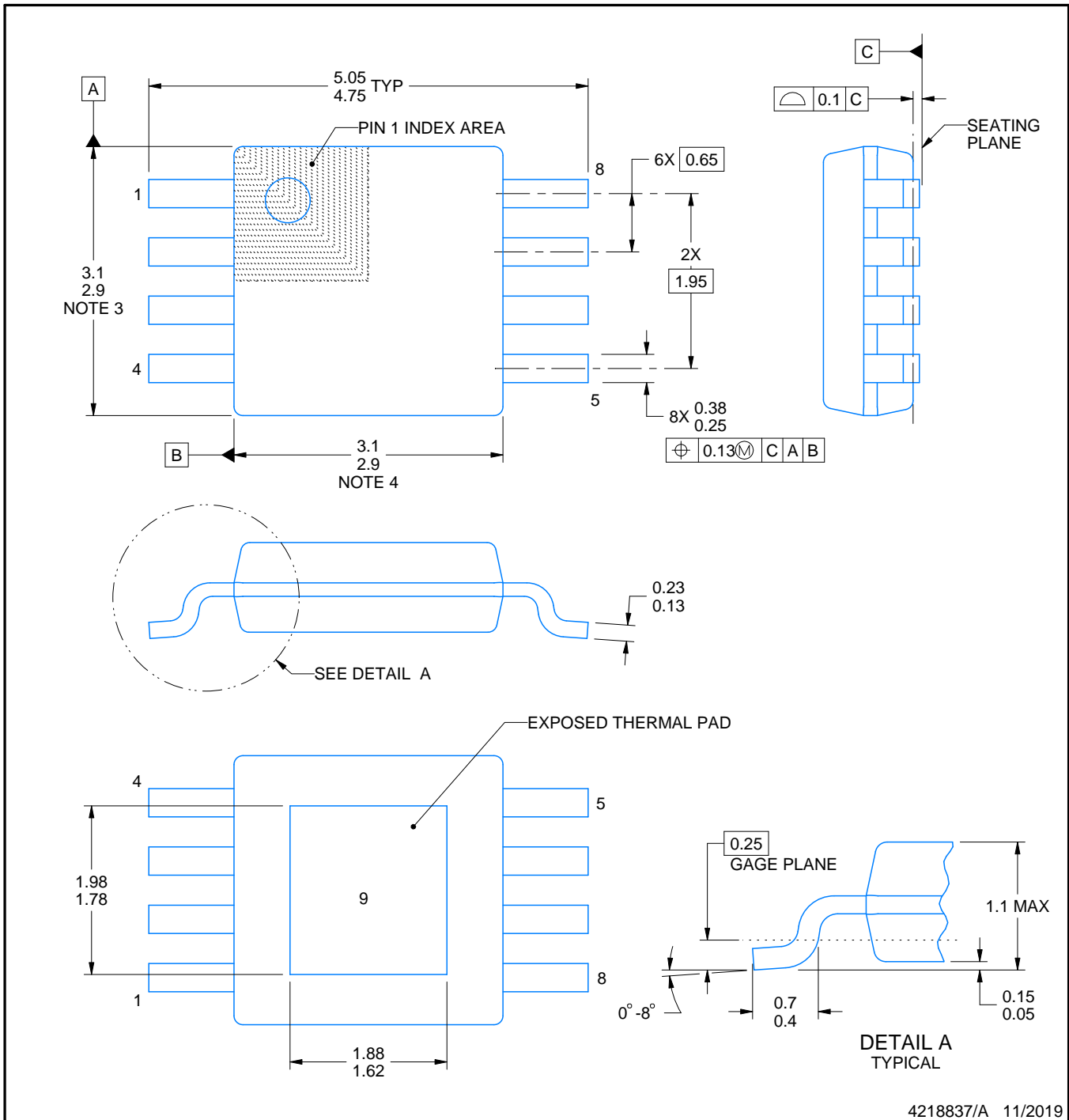
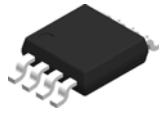

NOTES:

PowerPAD is a trademark of Texas Instruments.

1. All linear dimensions are in millimeters. Any dimensions in parenthesis are for reference only. Dimensioning and tolerancing per ASME Y14.5M.
2. This drawing is subject to change without notice.
3. This dimension does not include mold flash, protrusions, or gate burrs. Mold flash, protrusions, or gate burrs shall not exceed 0.15 mm per side.
4. This dimension does not include interlead flash. Interlead flash shall not exceed 0.25 mm per side.
5. Reference JEDEC registration MO-187.

# EXAMPLE BOARD LAYOUT

DGN0008B

PowerPAD™ VSSOP - 1.1 mm max height

SMALL OUTLINE PACKAGE

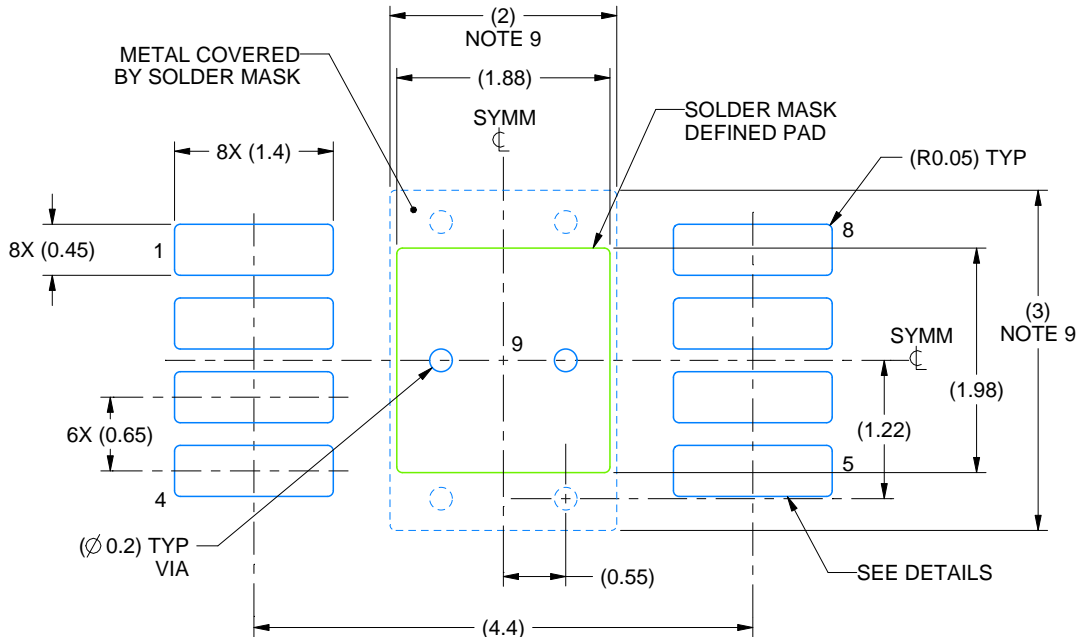

LAND PATTERN EXAMPLE  
EXPOSED METAL SHOWN  
SCALE: 15X

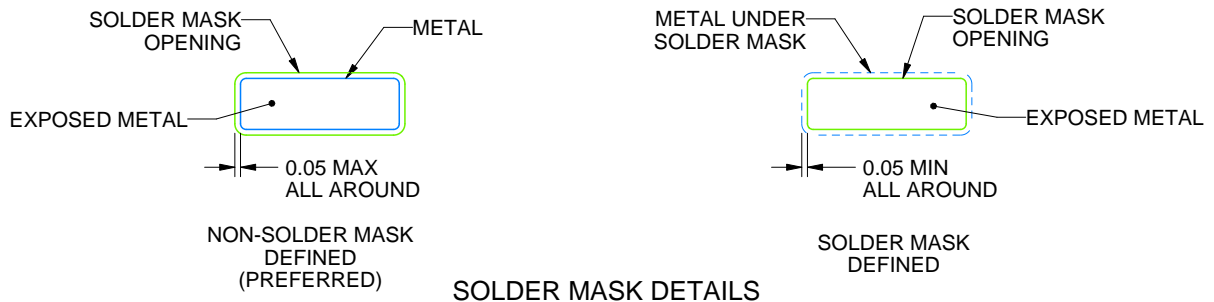

4218837/A 11/2019

NOTES: (continued)

- 6. Publication IPC-7351 may have alternate designs.
- 7. Solder mask tolerances between and around signal pads can vary based on board fabrication site.
- 8. Vias are optional depending on application, refer to device data sheet. If any vias are implemented, refer to their locations shown on this view. It is recommended that vias under paste be filled, plugged or tented.
- 9. Size of metal pad may vary due to creepage requirement.

# EXAMPLE STENCIL DESIGN

DGN0008B

PowerPAD™ VSSOP - 1.1 mm max height

SMALL OUTLINE PACKAGE

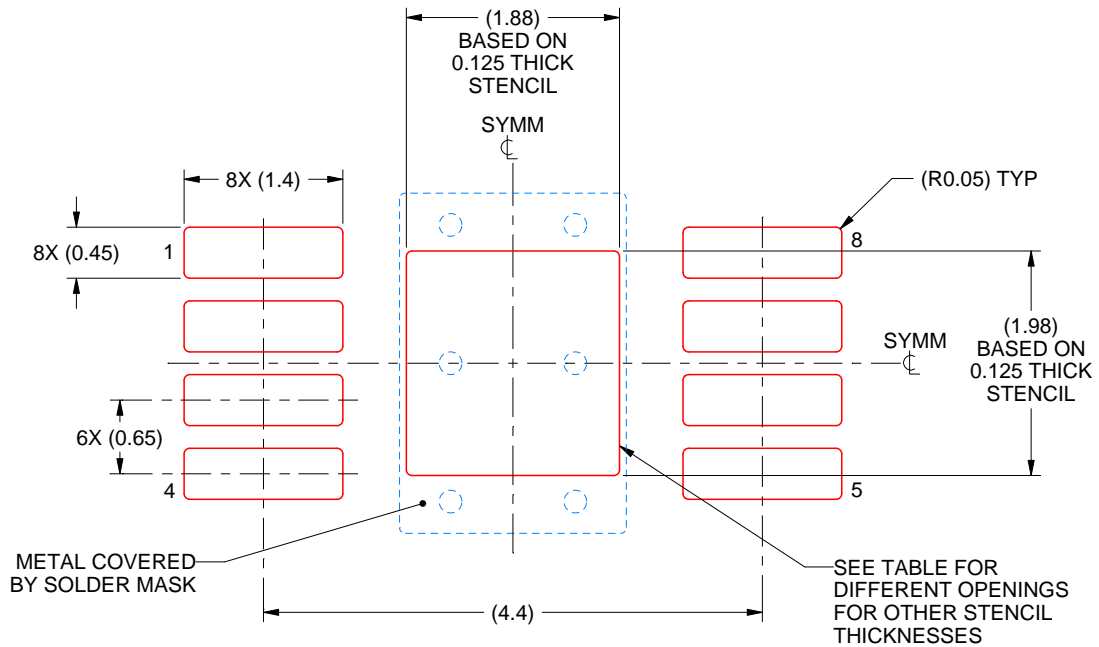

**SOLDER PASTE EXAMPLE**  
EXPOSED PAD 9:  
100% PRINTED SOLDER COVERAGE BY AREA  
SCALE: 15X

STENCIL THICKNESS	SOLDER STENCIL OPENING
0.1	2.10 X 2.21
0.125	1.88 X 1.98 (SHOWN)
0.15	1.72 X 1.81
0.175	1.59 X 1.67

4218837/A 11/2019

NOTES: (continued)

10. Laser cutting apertures with trapezoidal walls and rounded corners may offer better paste release. IPC-7525 may have alternate design recommendations.
11. Board assembly site may have different recommendations for stencil design.

## 重要声明和免责声明

TI 均以“原样”提供技术性及其可靠性数据（包括数据表）、设计资源（包括参考设计）、应用或其他设计建议、网络工具、安全信息和其他资源，不保证其中不含任何瑕疵，且不做任何明示或暗示的担保，包括但不限于对适销性、适合某特定用途或不侵犯任何第三方知识产权的暗示担保。

所述资源可供专业开发人员应用TI 产品进行设计使用。您将对以下行为独自承担全部责任：(1) 针对您的应用选择合适的TI 产品；(2) 设计、验证并测试您的应用；(3) 确保您的应用满足相应标准以及任何其他安全、安保或其他要求。所述资源如有变更，恕不另行通知。TI 对您使用所述资源的授权仅限于开发资源所涉及TI 产品的相关应用。除此之外不得复制或展示所述资源，也不提供其它TI 或任何第三方的知识产权授权许可。如因使用所述资源而产生任何索赔、赔偿、成本、损失及债务等，TI 对此概不负责，并且您须赔偿由此对TI 及其代表造成的损害。

TI 所提供产品均受TI 的销售条款 (<http://www.ti.com.cn/zh-cn/legal/termsofsale.html>) 以及ti.com.cn 上或随附TI 产品提供的其他可适用条款的约束。TI 提供所述资源并不扩展或以其他方式更改TI 针对TI 产品所发布的可适用的担保范围或担保免责声明。

邮寄地址：上海市浦东新区世纪大道 1568 号中建大厦 32 楼，邮政编码：200122

Copyright © 2020 德州仪器半导体技术（上海）有限公司