

## ADC081S021 Single-Channel, 50-kSPS to 200-kSPS, 8-Bit A/D Converter

### 1 Features

- Characterized and Specified Over Multiple Sample Rates
- 6-Pin WSON and SOT-23 Packages
- Variable Power Management
- Single Power Supply With 2.7-V to 5.25-V Range
- Compatible With SPI™, QSPI™, MICROWIRE™, and DSP
- DNL: +0.04/–0.03 LSB (Typical)
- INL: +0.04/–0.03 LSB (Typical)
- SNR: 49.6 dB (Typical)
- Power Consumption:
  - 3.6-V Supply: 1.3 mW (Typical)
  - 5.25-V Supply: 7.7 mW (Typical)

### 2 Applications

- Portable Systems
- Remote Data Acquisition
- Instrumentation and Control Systems

### 3 Description

The ADC081S021 device is a low-power, single-channel CMOS 8-bit analog-to-digital converter with a high-speed serial interface. Unlike the conventional practice of specifying performance at a single sample rate only, the ADC081S021 is fully specified over a sample rate range of 50 kSPS to 200 kSPS. The converter is based upon a successive-approximation register architecture with an internal track-and-hold circuit.

The output serial data is straight binary, and is compatible with several standards, such as SPI, QSPI, MICROWIRE, and many common DSP serial interfaces.

The ADC081S021 operates with a single supply that can range from 2.7 V to 5.25 V. Normal power consumption using a 3.6-V or 5.25-V supply is 1.3 mW and 7.7 mW, respectively. The power-down feature reduces the power consumption to as low as 2.6  $\mu$ W using a 5.25-V supply.

The ADC081S021 is packaged in 6-pin WSON and SOT-23 packages. Operation over the industrial temperature range of –40°C to 85°C is ensured.

#### Device Information<sup>(1)</sup>

PART NUMBER	PACKAGE	BODY SIZE (NOM)
ADC081S021	SOT-23 (6)	2.50 mm × 2.20 mm
	WSON (6)	1.60 mm × 2.90 mm

(1) For all available packages, see the orderable addendum at the end of the data sheet.

#### Block Diagram

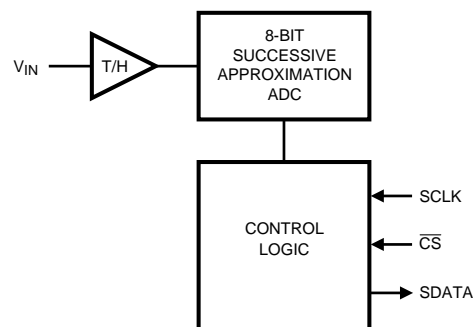

Copyright © 2016, Texas Instruments Incorporated



## Table of Contents

<b>1 Features</b> .....	<b>1</b>	8.4 Device Functional Modes.....	<b>13</b>
<b>2 Applications</b> .....	<b>1</b>	<b>9 Application and Implementation</b> .....	<b>16</b>
<b>3 Description</b> .....	<b>1</b>	9.1 Application Information.....	<b>16</b>
<b>4 Revision History</b> .....	<b>2</b>	9.2 Typical Application .....	<b>17</b>
<b>5 Device Comparison Table</b> .....	<b>3</b>	<b>10 Power Supply Recommendations</b> .....	<b>19</b>
<b>6 Pin Configuration and Functions</b> .....	<b>3</b>	10.1 Noise Considerations.....	<b>19</b>
<b>7 Specifications</b> .....	<b>4</b>	<b>11 Layout</b> .....	<b>19</b>
7.1 Absolute Maximum Ratings .....	<b>4</b>	11.1 Layout Guidelines .....	<b>19</b>
7.2 ESD Ratings.....	<b>4</b>	11.2 Layout Example .....	<b>20</b>
7.3 Recommended Operating Conditions.....	<b>4</b>	<b>12 Device and Documentation Support</b> .....	<b>21</b>
7.4 Thermal Information .....	<b>5</b>	12.1 Device Support.....	<b>21</b>
7.5 Electrical Characteristics.....	<b>5</b>	12.2 Documentation Support .....	<b>22</b>
7.6 Timing Requirements .....	<b>7</b>	12.3 Community Resources.....	<b>22</b>
7.7 Typical Characteristics .....	<b>9</b>	12.4 Trademarks .....	<b>22</b>
<b>8 Detailed Description</b> .....	<b>12</b>	12.5 Electrostatic Discharge Caution.....	<b>22</b>
8.1 Overview .....	<b>12</b>	12.6 Glossary .....	<b>22</b>
8.2 Functional Block Diagram .....	<b>12</b>	<b>13 Mechanical, Packaging, and Orderable Information</b> .....	<b>22</b>
8.3 Feature Description.....	<b>12</b>		

## 4 Revision History

NOTE: Page numbers for previous revisions may differ from page numbers in the current version.

<b>Changes from Revision F (November 2013) to Revision G</b>	<b>Page</b>
• Added <i>ESD Ratings</i> table, <i>Feature Description</i> section, <i>Device Functional Modes</i> , <i>Application and Implementation</i> section, <i>Power Supply Recommendations</i> section, <i>Layout</i> section, <i>Device and Documentation Support</i> section, and <i>Mechanical, Packaging, and Orderable Information</i> section .....	<b>1</b>
• Changed table title <i>Pin-Compatible Alternatives by Resolution and Speed</i> to <i>Device Comparison Table</i> .....	<b>3</b>

<b>Changes from Revision E (March 2013) to Revision F</b>	<b>Page</b>
• Changed sentence in the "Using the ADC081S021" section .....	<b>12</b>

<b>Changes from Revision D (March 2013) to Revision E</b>	<b>Page</b>
• Changed layout of National Data Sheet to TI format .....	<b>1</b>

## 5 Device Comparison Table

RESOLUTION	SPECIFIED SAMPLE RATE RANGE <sup>(1)</sup>		
	50 TO 200 KSPS	200 TO 500 KSPS	500 KSPS TO 1 MSPS
12 Bits	ADC081S021121S021	ADC081S021121S051	ADC081S021121S101
10 Bits	ADC081S021101S021	ADC081S021101S051	ADC081S021101S101
8 Bits	ADC081S021	ADC081S021081S051	ADC081S021081S101

(1) All devices are fully pin and function compatible.

## 6 Pin Configuration and Functions

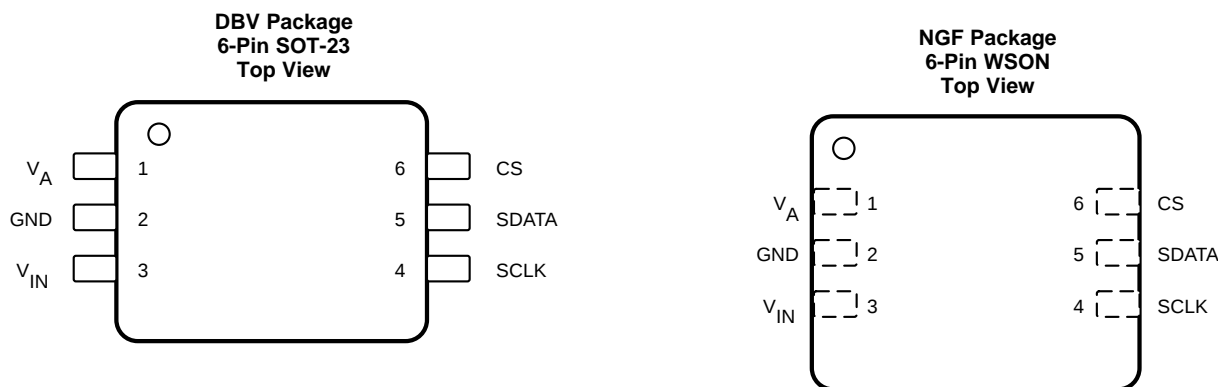

### Pin Functions

PIN		TYPE <sup>(1)</sup>	DESCRIPTION
NO.	NAME		
1	V <sub>A</sub>	P	Positive supply pin. This pin must be connected to a quiet 2.7-V to 5.25-V source and bypassed to GND with a 1-μF capacitor and a 0.1-μF monolithic capacitor placed within 1 cm of the power pin.
2	GND	G	The ground return for the supply and signals.
3	V <sub>IN</sub>	I	Analog input. This signal can range from 0 V to V <sub>A</sub> .
4	SCLK	I	Digital clock input. This clock directly controls the conversion and readout processes.
5	SDATA	O	Digital data output. The output samples are clocked out of this pin on falling edges of the SCLK pin.
6	$\overline{CS}$	I	Chip select. On the falling edge of $\overline{CS}$ , a conversion process begins.

(1) G = Ground, I = Input, O = Output, P = Power

## 7 Specifications

### 7.1 Absolute Maximum Ratings

 over operating free-air temperature range (unless otherwise noted)<sup>(1)(2)(3)</sup>

	MIN	MAX	UNIT
Analog supply voltage, $V_A$	-0.3	6.5	V
Voltage on any analog pin to GND	-0.3	$V_A + 0.3$	V
Voltage on any digital pin to GND	-0.3	6.5	V
Input current at any pin <sup>(4)</sup>		±10	mA
Package input current <sup>(4)</sup>		±20	mA
Power consumption at $T_A = 25^\circ\text{C}$		See <sup>(5)</sup>	
Junction temperature, $T_J$		150	$^\circ\text{C}$
Storage temperature, $T_{\text{stg}}$	-65	150	$^\circ\text{C}$

- Stresses beyond those listed under *Absolute Maximum Ratings* may cause permanent damage to the device. These are stress ratings only, which do not imply functional operation of the device at these or any other conditions beyond those indicated under *Recommended Operating Conditions*. Exposure to absolute-maximum-rated conditions for extended periods may affect device reliability.
- All voltages are measured with respect to GND = 0 V, unless otherwise specified.
- If Military/Aerospace specified devices are required, please contact the TI Office/Distributors for availability and specifications.
- When the input voltage at any pin exceeds the power supply (that is,  $V_{\text{IN}} < \text{GND}$  or  $V_{\text{IN}} > V_A$ ), the current at that pin must be limited to 10 mA. The 20 mA maximum package input current rating limits the number of pins that can safely exceed the power supplies with an input current of 10 mA to two. These specifications do not apply to the  $V_A$  pin. The current into the  $V_A$  pin is limited by the analog supply voltage specification.
- The absolute maximum junction temperature ( $T_{\text{Jmax}}$ ) for this device is  $150^\circ\text{C}$ . The maximum allowable power dissipation is dictated by  $T_{\text{Jmax}}$ , the junction-to-ambient thermal resistance ( $\theta_{\text{JA}}$ ), and the ambient temperature ( $T_A$ ), and can be calculated using the formula  $P_{\text{DMAX}} = (T_{\text{Jmax}} - T_A) / \theta_{\text{JA}}$ . The values for maximum power dissipation listed above is reached only when the device is operated in a severe fault condition (that is, when input or output pins are driven beyond the power supply voltages, or the power supply polarity is reversed). Such conditions must always be avoided.

### 7.2 ESD Ratings

	VALUE	UNIT
$V_{\text{(ESD)}}$ Electrostatic discharge <sup>(1)</sup>	Human-body model (HBM), per ANSI/ESDA/JEDEC JS-001 <sup>(2)</sup>	±3500
	Machine model (MM)	±300

- Human body model is 100-pF capacitor discharged through a 1.5-k $\Omega$  resistor. Machine model is 220 pF discharged through 0  $\Omega$ .
- JEDEC document JEP155 states that 500-V HBM allows safe manufacturing with a standard ESD control process.

### 7.3 Recommended Operating Conditions

 over operating free-air temperature range (unless otherwise noted)<sup>(1)</sup>

	MIN	MAX	UNIT
$V_A$ Supply voltage	2.7	5.25	V
Digital input pins voltage (regardless of supply voltage)	-0.3	5.25	V
Analog input pins voltage	0	$V_A$	V
Clock frequency	25	20000	kHz
Sample rate		1	Msp/s
$T_A$ Operating temperature	-40	85	$^\circ\text{C}$

- All voltages are measured with respect to GND = 0 V, unless otherwise specified.

## 7.4 Thermal Information

THERMAL METRIC <sup>(1)</sup>		ADC081S021		UNIT
		DBV (SOT-23)	NGF (WSON)	
		6 PINS	6 PINS	
R <sub>θJA</sub>	Junction-to-ambient thermal resistance	184.5	99.8	°C/W
R <sub>θJC(top)</sub>	Junction-to-case (top) thermal resistance	151.2	118.3	°C/W
R <sub>θJB</sub>	Junction-to-board thermal resistance	29.7	68.9	°C/W
ψ <sub>JT</sub>	Junction-to-top characterization parameter	29.8	6.6	°C/W
ψ <sub>JB</sub>	Junction-to-board characterization parameter	29.1	69.2	°C/W
R <sub>θJC(bot)</sub>	Junction-to-case (bottom) thermal resistance	—	14.8	°C/W

(1) For more information about traditional and new thermal metrics, see the *Semiconductor and IC Package Thermal Metrics* application report, [SPRA953](#).

## 7.5 Electrical Characteristics

Typical values correspond to T<sub>A</sub> = 25°C, and minimum and maximum limits apply over –40°C to 85°C operating temperature range (unless otherwise noted). V<sub>A</sub> = 2.7 V to 5.25 V, f<sub>SCLK</sub> = 1 MHz to 4 MHz, f<sub>SAMPLE</sub> = 50 kps to 200 kps, and C<sub>L</sub> = 15 pF (unless otherwise noted).<sup>(1)</sup>

PARAMETER		TEST CONDITIONS		MIN <sup>(2)</sup>	TYP	MAX <sup>(2)</sup>	UNIT
<b>STATIC CONVERTER CHARACTERISTICS</b>							
Resolution with no missing codes						8	Bits
INL	Integral non-linearity	V <sub>A</sub> = 2.7 V to 3.6 V			±0.03	±0.3	LSB
		V <sub>A</sub> = 4.75 V to 5.25 V	T <sub>A</sub> = 25°C	–0.03		0.04	LSB
T <sub>A</sub> = –40°C to 85°C	±0.3			±0.3			
DNL	Differential non-linearity	V <sub>A</sub> = 2.7 V to 3.6 V			±0.03	±0.2	LSB
		V <sub>A</sub> = 4.75 V to 5.25 V	T <sub>A</sub> = 25°C	–0.03		0.04	LSB
T <sub>A</sub> = –40°C to 85°C	±0.2			±0.2			
V <sub>OFF</sub>	Offset error	V <sub>A</sub> = 2.7 V to 3.6 V			–0.01	±0.2	LSB
		V <sub>A</sub> = 4.75 V to 5.25 V			0.03	±0.2	LSB
GE	Gain error	V <sub>A</sub> = 2.7 V to 3.6 V			0.04	±0.4	LSB
		V <sub>A</sub> = 4.75 V to 5.25 V			0.1	±0.4	LSB
TUE	Total unadjusted error	V <sub>A</sub> = 2.7 V to 3.6 V	T <sub>A</sub> = 25°C	–0.065		0.055	LSB
			T <sub>A</sub> = –40°C to 85°C	±0.3		±0.3	
		V <sub>A</sub> = 4.75 V to 5.25 V	T <sub>A</sub> = 25°C	–0.06		0.03	LSB
			T <sub>A</sub> = –40°C to 85°C	±0.3		±0.3	
<b>DYNAMIC CONVERTER CHARACTERISTICS</b>							
SINAD	Signal-to-noise plus distortion ratio	V <sub>A</sub> = 2.7 V to 5.25 V, f <sub>IN</sub> = 100 kHz, –0.02 dBFS		49	49.5		dBFS
SNR	Signal-to-noise ratio	V <sub>A</sub> = 2.7 V to 5.25 V, f <sub>IN</sub> = 100 kHz, –0.02 dBFS		49	49.6		dBFS
THD	Total harmonic distortion	V <sub>A</sub> = 2.7 V to 5.25 V, f <sub>IN</sub> = 100 kHz, –0.02 dBFS			–77	–65	dBFS
SFDR	Spurious-free dynamic range	V <sub>A</sub> = 2.7 V to 5.25 V, f <sub>IN</sub> = 100 kHz, –0.02 dBFS		65	68		dBFS
ENOB	Effective number of bits	V <sub>A</sub> = 2.7 V to 5.25 V, f <sub>IN</sub> = 100 kHz, –0.02 dBFS		7.8	7.9		Bits
IMD	Intermodulation distortion, second order terms	V <sub>A</sub> = 5.25 V, f <sub>a</sub> = 103.5 kHz, f <sub>b</sub> = 113.5 kHz			–83		dBFS
	Intermodulation distortion, third order terms	V <sub>A</sub> = 5.25 V, f <sub>a</sub> = 103.5 kHz, f <sub>b</sub> = 113.5 kHz			–82		dBFS

(1) Tested limits are ensured to TI's AOQL (Average Outgoing Quality Level).

(2) Data sheet minimum and maximum specification limits are specified by design, test, or statistical analysis.

## Electrical Characteristics (continued)

Typical values correspond to  $T_A = 25^\circ\text{C}$ , and minimum and maximum limits apply over  $-40^\circ\text{C}$  to  $85^\circ\text{C}$  operating temperature range (unless otherwise noted).  $V_A = 2.7\text{ V}$  to  $5.25\text{ V}$ ,  $f_{\text{SCLK}} = 1\text{ MHz}$  to  $4\text{ MHz}$ ,  $f_{\text{SAMPLE}} = 50\text{ kpsps}$  to  $200\text{ kpsps}$ , and  $C_L = 15\text{ pF}$  (unless otherwise noted).<sup>(1)</sup>

PARAMETER		TEST CONDITIONS	MIN <sup>(2)</sup>	TYP	MAX <sup>(2)</sup>	UNIT
FPBW	–3 dB full power bandwidth	$V_A = 5\text{ V}$		11		MHz
		$V_A = 3\text{ V}$		8		MHz
<b>ANALOG INPUT CHARACTERISTICS</b>						
$V_{\text{IN}}$	Input range		0 to $V_A$			V
$I_{\text{DCL}}$	DC leakage current				$\pm 1$	$\mu\text{A}$
$C_{\text{INA}}$	Input capacitance	Track mode		30		pF
		Hold mode		4		pF
<b>DIGITAL INPUT CHARACTERISTICS</b>						
$V_{\text{IH}}$	Input high voltage	$V_A = 5.25\text{ V}$	2.4			V
		$V_A = 3.6\text{ V}$	2.1			V
$V_{\text{IL}}$	Input low voltage	$V_A = 5\text{ V}$			0.8	V
		$V_A = 3\text{ V}$			0.4	V
$I_{\text{IN}}$	Input current	$V_{\text{IN}} = 0\text{ V}$ or $V_A$		$\pm 0.1$	$\pm 1$	$\mu\text{A}$
$C_{\text{IND}}$	Digital input capacitance			2	4	pF
<b>DIGITAL OUTPUT CHARACTERISTICS</b>						
$V_{\text{OH}}$	Output high voltage	$I_{\text{SOURCE}} = 200\text{ }\mu\text{A}$	$V_A - 0.2$	$V_A - 0.07$		V
		$I_{\text{SOURCE}} = 1\text{ mA}$		$V_A - 0.1$		V
$V_{\text{OL}}$	Output low voltage	$I_{\text{SINK}} = 200\text{ }\mu\text{A}$		0.03	0.4	V
		$I_{\text{SINK}} = 1\text{ mA}$		0.1		V
$I_{\text{OZH}}, I_{\text{OZL}}$	TRI-STATE leakage current			$\pm 0.1$	$\pm 10$	$\mu\text{A}$
$C_{\text{OUT}}$	TRI-STATE output capacitance			2	4	pF
	Output coding		Straight (natural) binary			
<b>POWER SUPPLY CHARACTERISTICS</b>						
$V_A$	Supply voltage		2.7		5.25	V
$I_A$	Supply current, normal mode (operational, $\overline{\text{CS}}$ low)	$V_A = 5.25\text{ V}$ , $f_{\text{SAMPLE}} = 200\text{ kpsps}$		1.47	2.2	mA
		$V_A = 3.6\text{ V}$ , $f_{\text{SAMPLE}} = 200\text{ kpsps}$		0.36	0.9	mA
	Supply current, shutdown ( $\overline{\text{CS}}$ high)	$f_{\text{SCLK}} = 0\text{ MHz}$ , $V_A = 5.25\text{ V}$ , $f_{\text{SAMPLE}} = 0\text{ kpsps}$		500		nA
		$V_A = 5.25\text{ V}$ , $f_{\text{SCLK}} = 4\text{ MHz}$ , $f_{\text{SAMPLE}} = 0\text{ kpsps}$		60		$\mu\text{A}$
$P_D$	Power consumption, normal mode (operational, $\overline{\text{CS}}$ low)	$V_A = 5.25\text{ V}$		7.7	11.6	mW
		$V_A = 3.6\text{ V}$		1.3	3.24	mW
	Power consumption, shutdown ( $\overline{\text{CS}}$ high)	$f_{\text{SCLK}} = 0\text{ MHz}$ , $V_A = 5.25\text{ V}$ , $f_{\text{SAMPLE}} = 0\text{ kpsps}$		2.6		$\mu\text{W}$
		$f_{\text{SCLK}} = 4\text{ MHz}$ , $V_A = 5.25\text{ V}$ , $f_{\text{SAMPLE}} = 0\text{ kpsps}$		315		$\mu\text{W}$
<b>AC ELECTRICAL CHARACTERISTICS</b>						
$f_{\text{SCLK}}$	Clock frequency	See <sup>(3)</sup>	1		4	MHz
$f_S$	Sample rate	See <sup>(3)</sup>	50		200	kpsps
$t_{\text{HOLD}}$	Hold time, falling edge				13	SCLK
DC	SCLK duty cycle	$f_{\text{SCLK}} = 4\text{ MHz}$	40%	50%	60%	
$t_{\text{ACQ}}$	Minimum time required for acquisition				350	ns
$t_{\text{QUIET}}$	Quiet time	See <sup>(4)</sup>	50			ns
$t_{\text{AD}}$	Aperture delay			3		ns
$t_{\text{AJ}}$	Aperture jitter			30		ps

(3) This is the frequency range over which the electrical performance is ensured. The device is functional over a wider range which is specified under Operating Ratings.

(4) Minimum quiet time required by bus relinquish and the start of the next conversion.

## 7.6 Timing Requirements

The following specifications apply for  $V_A = 2.7\text{ V}$  to  $5.25\text{ V}$ ,  $GND = 0\text{ V}$ ,  $f_{SCLK} = 1.0\text{ MHz}$  to  $4.0\text{ MHz}$ ,  $C_L = 25\text{ pF}$ ,  $f_{SAMPLE} = 50\text{ kpsps}$  to  $200\text{ kpsps}$ , and  $T_A = -40^\circ\text{C}$  to  $85^\circ\text{C}$  (unless otherwise noted).<sup>(1)</sup>

PARAMETER	TEST CONDITIONS	MIN	TYP	MAX	UNIT
$t_{CS}$	Minimum $\overline{CS}$ pulse width	10			ns
$t_{CSSU}$	$\overline{CS}$ setup time prior to SCLK falling edge	10			ns
$t_{CSH}$	$\overline{CS}$ hold time after SCLK falling edge	1			ns
$t_{EN}$	Delay from $\overline{CS}$ until SDATA TRI-STATE disabled <sup>(2)</sup>			20	ns
$t_{ACC}$	Data access time after SCLK falling edge <sup>(3)</sup>	$V_A = 2.7\text{ V}$ to $3.6\text{ V}$		40	ns
		$V_A = 4.75\text{ V}$ to $5.25\text{ V}$		20	ns
$t_{CL}$	SCLK low pulse width	$0.4 \times t_{SCLK}$			ns
$t_{CH}$	SCLK high pulse width	$0.4 \times t_{SCLK}$			ns
$t_H$	SCLK to data valid hold time	$V_A = 2.7\text{ V}$ to $3.6\text{ V}$	7		ns
		$V_A = 4.75\text{ V}$ to $5.25\text{ V}$	5		ns
$t_{DIS}$	SCLK falling edge to SDATA high impedance <sup>(4)</sup>	$V_A = 2.7\text{ V}$ to $3.6\text{ V}$	6	25	ns
		$V_A = 4.75\text{ V}$ to $5.25\text{ V}$	5	25	ns
$t_{POWER-UP}$	Power-up time from full power down	$T_A = 25^\circ\text{C}$	1		$\mu\text{s}$

- (1) Data sheet minimum and maximum specification limits are specified by design, test, or statistical analysis.
- (2) Measured with the timing test circuit and defined as the time taken by the output signal to cross 1 V.
- (3) Measured with the timing test circuit and defined as the time taken by the output signal to cross 1 V or 2 V.
- (4)  $t_{DIS}$  is derived from the time taken by the outputs to change by 0.5 V with the timing test circuit. The measured number is then adjusted to remove the effects of charging or discharging the output capacitance. This means that  $t_{DIS}$  is the true bus relinquish time, independent of the bus loading.

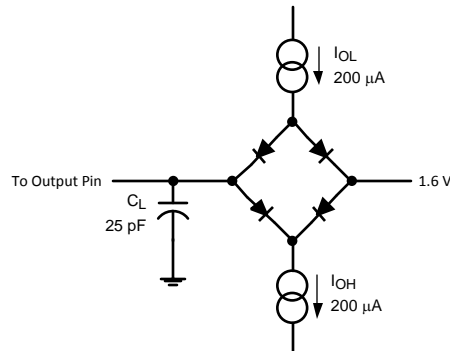

Figure 1. Timing Test Circuit

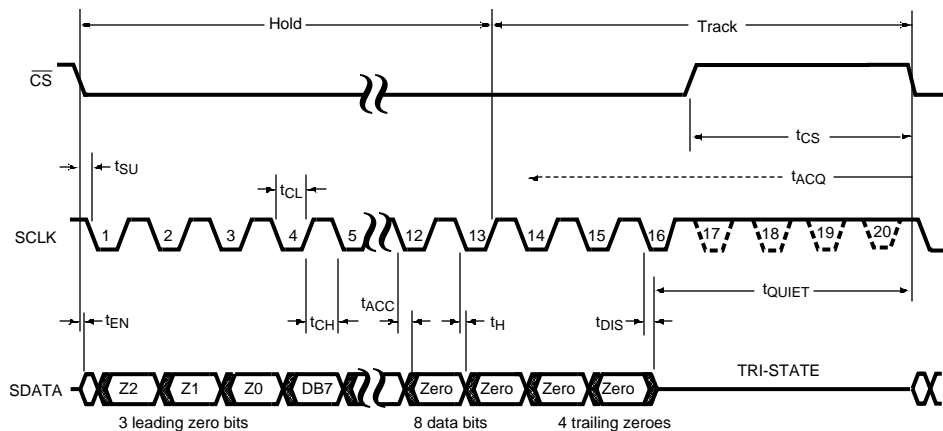

Figure 2. Serial Timing Diagram

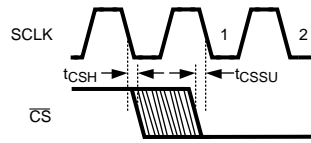

Figure 3. SCLK and  $\overline{CS}$  Timing Parameters

## 7.7 Typical Characteristics

$T_A = 25^\circ\text{C}$ ,  $f_{\text{SAMPLE}} = 50 \text{ kpsps to } 200 \text{ kpsps}$ ,  $f_{\text{SCLK}} = 1 \text{ MHz to } 4 \text{ MHz}$ ,  $f_{\text{IN}} = 100 \text{ kHz}$  (unless otherwise noted)

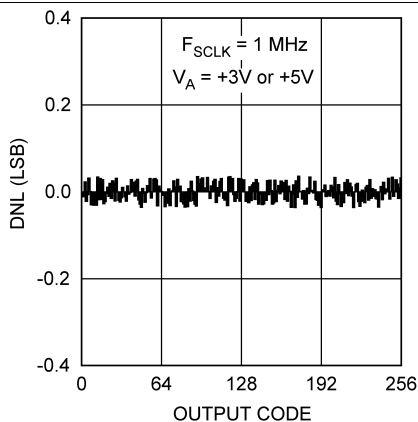

Figure 4. DNL  $f_{\text{SCLK}} = 1 \text{ MHz}$

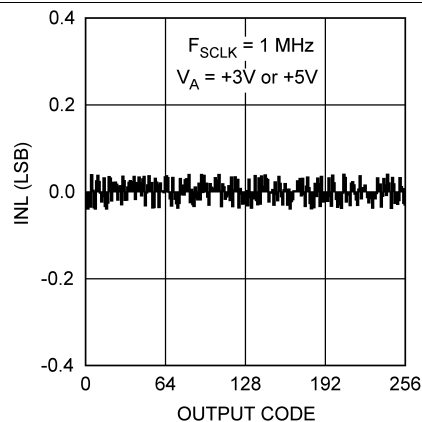

Figure 5. INL  $f_{\text{SCLK}} = 1 \text{ MHz}$

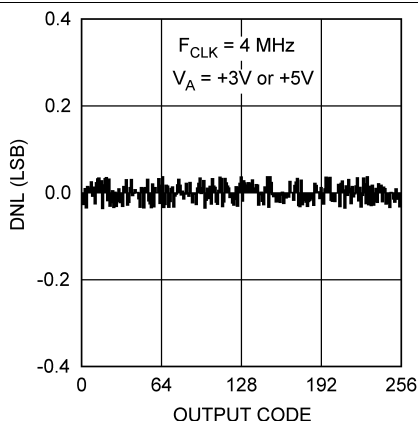

Figure 6. DNL  $f_{\text{SCLK}} = 4 \text{ MHz}$

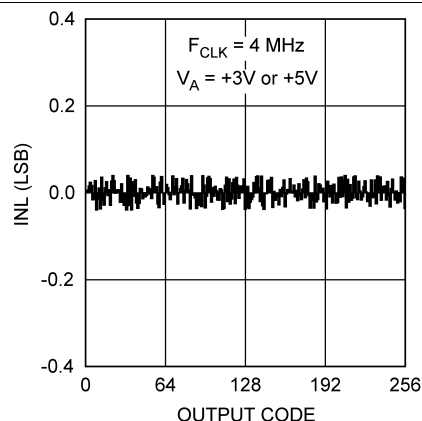

Figure 7. INL  $f_{\text{SCLK}} = 4 \text{ MHz}$

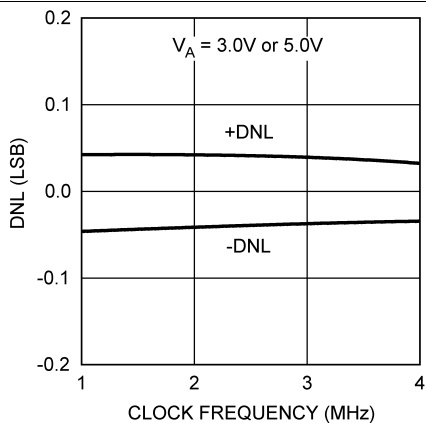

Figure 8. DNL vs Clock Frequency

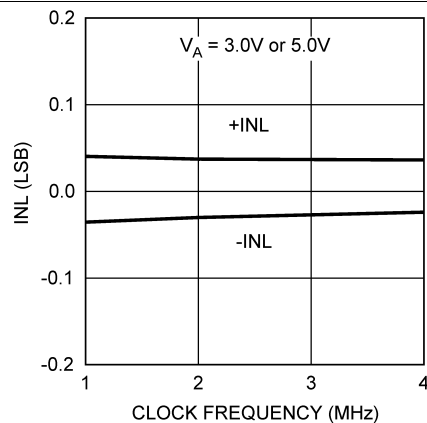
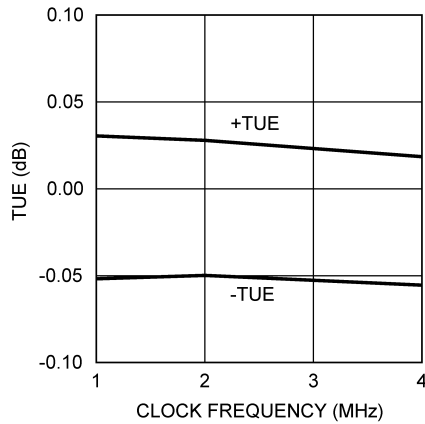
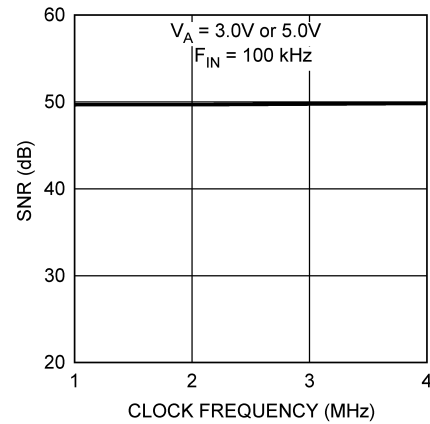
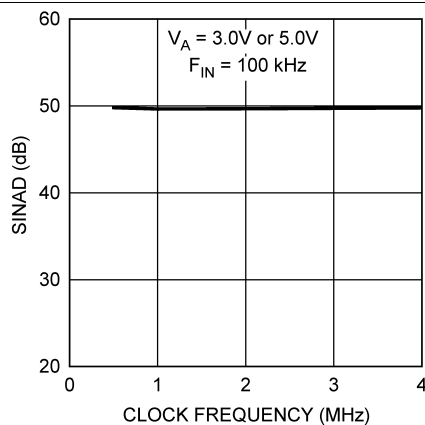
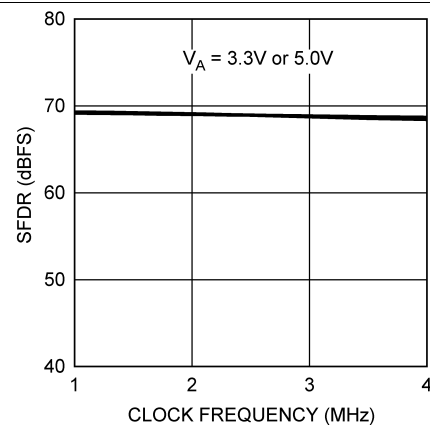
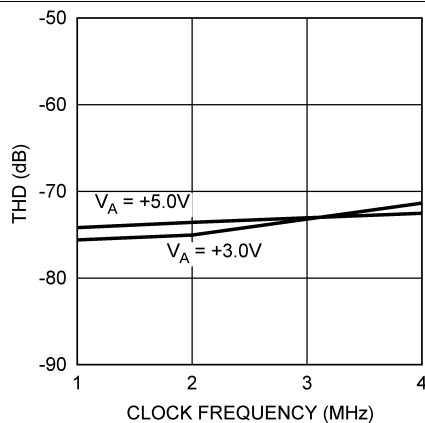
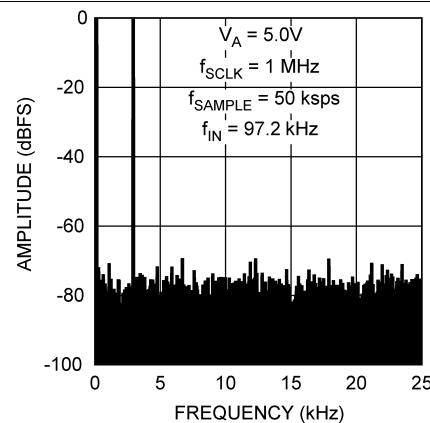
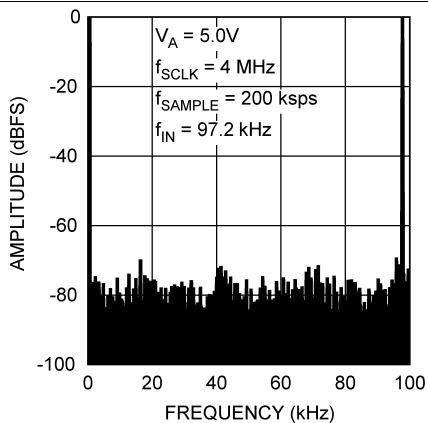

Figure 9. INL vs Clock Frequency

**Typical Characteristics (continued)**
 $T_A = 25^\circ\text{C}$ ,  $f_{\text{SAMPLE}} = 50 \text{ kpsps to } 200 \text{ kpsps}$ ,  $f_{\text{SCLK}} = 1 \text{ MHz to } 4 \text{ MHz}$ ,  $f_{\text{IN}} = 100 \text{ kHz}$  (unless otherwise noted)

**Figure 10. Total Unadjusted Error vs Clock Frequency**  
 $V_A = 3 \text{ V or } 5 \text{ V}$ 

**Figure 11. SNR vs Clock Frequency**

**Figure 12. SINAD vs Clock Frequency**

**Figure 13. SFDR vs Clock Frequency**

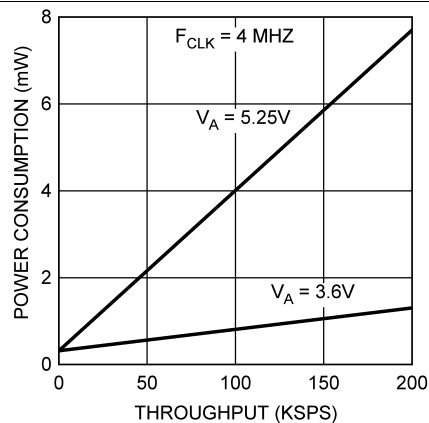
**Figure 14. THD vs Clock Frequency**

**Figure 15. Spectral Response,  $V_A = 5 \text{ V}$**   
 $f_{\text{SCLK}} = 1 \text{ MHz}$

**Typical Characteristics (continued)**

$T_A = 25^\circ\text{C}$ ,  $f_{\text{SAMPLE}} = 50 \text{ kpsps to } 200 \text{ kpsps}$ ,  $f_{\text{SCLK}} = 1 \text{ MHz to } 4 \text{ MHz}$ ,  $f_{\text{IN}} = 100 \text{ kHz}$  (unless otherwise noted)



**Figure 16. Spectral Response,  $V_A = 5 \text{ V}$   
 $f_{\text{SCLK}} = 4 \text{ MHz}$**



**Figure 17. Power Consumption vs Throughput  
 $f_{\text{SCLK}} = 4 \text{ MHz}$**

## 8 Detailed Description

### 8.1 Overview

The ADC081S021 is a successive-approximation analog-to-digital converter designed around a charge-redistribution digital-to-analog converter core. Simplified schematics of the ADC081S021 in both track and hold modes are shown in [Figure 19](#) and [Figure 18](#), respectively. In [Figure 19](#), the device is in track mode: switch SW1 connects the sampling capacitor to the input, and SW2 balances the comparator inputs. The device is in this state until  $\overline{CS}$  is brought low, at which point the device moves to hold mode.

### 8.2 Functional Block Diagram

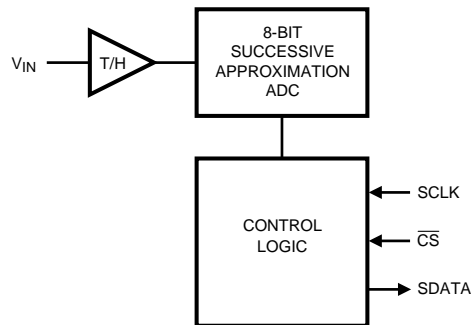

Copyright © 2016, Texas Instruments Incorporated

### 8.3 Feature Description

The serial interface timing diagram for the ADC is shown in [Timing Requirements](#).  $\overline{CS}$  is chip select, which initiates conversions on the ADC and frames the serial data transfers. SCLK (serial clock) controls both the conversion process and the timing of serial data. SDATA is the serial data out pin, where a conversion result is found as a serial data stream.

Basic operation of the ADC begins with  $\overline{CS}$  going low, which initiates a conversion process and data transfer. Subsequent rising and falling edges of SCLK are labelled with reference to the falling edge of  $\overline{CS}$ ; for example, *the third falling edge of SCLK* shall refer to the third falling edge of SCLK after  $\overline{CS}$  goes low.

At the fall of  $\overline{CS}$ , the SDATA pin comes out of TRI-STATE and the converter moves from track mode to hold mode. The input signal is sampled and held for conversion on the falling edge of  $\overline{CS}$ . The converter moves from hold mode to track mode on the 13th rising edge of SCLK (see [Timing Requirements](#)). It is at this point that the interval for the  $T_{ACQ}$  specification begins. At least 350 ns must pass between the 13th rising edge of SCLK and the next falling edge of  $\overline{CS}$ . The SDATA pin is placed back into TRI-STATE after the 16th falling edge of SCLK, or at the rising edge of  $\overline{CS}$ , whichever occurs first. After a conversion is completed, the quiet time ( $t_{QUIET}$ ) must be satisfied before bringing  $\overline{CS}$  low again to begin another conversion.

Sixteen SCLK cycles are required to read a complete sample from the ADC. The sample bits (including leading or trailing zeroes) are clocked out on falling edges of SCLK, and are intended to be clocked in by a receiver on subsequent rising edges of SCLK. The ADC produces three leading zero bits on SDATA, followed by eight data bits, most significant first. After the data bits, the ADC clocks out four trailing zeros.

If  $\overline{CS}$  goes low before the rising edge of SCLK, an additional (fourth) zero bit may be captured by the next falling edge of SCLK.

#### 8.3.1 Determining Throughput

Throughput depends on the frequency of SCLK and how much time is allowed to elapse between the end of one conversion and the start of another. At the maximum specified SCLK frequency, the maximum ensured throughput is obtained by using a 20 SCLK frame. As shown in [Timing Requirements](#), the minimum allowed time between  $\overline{CS}$  falling edges is determined by:

1. 12.5 SCLKs for Hold mode.
2. The larger of two quantities: either the minimum required time for Track mode ( $t_{ACQ}$ ) or 2.5 SCLKs to finish reading the result.

## Feature Description (continued)

- 0, 1/2, or 1 SCLK padding to ensure an even number of SCLK cycles so there is a falling SCLK edge when  $\overline{CS}$  next falls.

For example, at the fastest rate for this family of parts, SCLK is 20 MHz and 2.5 SCLKs are 125 ns, so the minimum time between  $\overline{CS}$  falling edges is calculated by Equation 1.

$$12.5 \times 50 \text{ ns} + 350 \text{ ns} + 0.5 \times 50 \text{ ns} = 1000 \text{ ns} \quad (1)$$

(12.5 SCLKs +  $t_{ACQ}$  + 1/2 SCLK) which corresponds to a maximum throughput of 1 MSPS. At the slowest rate for this family, SCLK is 1 MHz. Using a 20 cycle conversion frame as shown in [Timing Requirements](#) yields a 20- $\mu$ s time between  $\overline{CS}$  falling edges for a throughput of 50 KSPS. It is possible, however, to use fewer than 20 clock cycles provided the timing parameters are met. With a 1-MHz SCLK, there are 2500 ns in 2.5 SCLK cycles, which is greater than  $t_{ACQ}$ . After the last data bit has come out, the clock needs one full cycle to return to a falling edge. Thus the total time between falling edges of  $\overline{CS}$  is  $12.5 \times 1 \mu\text{s} + 2.5 \times 1 \mu\text{s} + 1 \times 1 \mu\text{s} = 16 \mu\text{s}$  which is a throughput of 62.5 KSPS.

## 8.4 Device Functional Modes

Figure 18 shows the device in hold mode: switch SW1 connects the sampling capacitor to ground, maintaining the sampled voltage, and switch SW2 unbalances the comparator. The control logic then instructs the charge-redistribution DAC to add or subtract fixed amounts of charge from the sampling capacitor until the comparator is balanced. When the comparator is balanced, the digital word supplied to the DAC is the digital representation of the analog input voltage. The device moves from hold mode to track mode (Figure 19) on the 13th rising edge of SCLK.

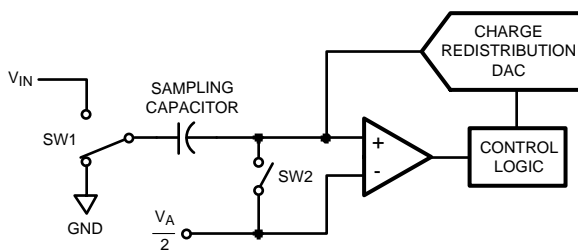

Figure 18. Hold Mode

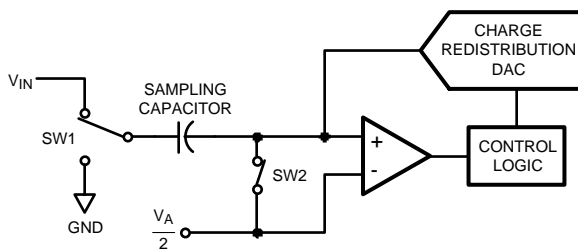
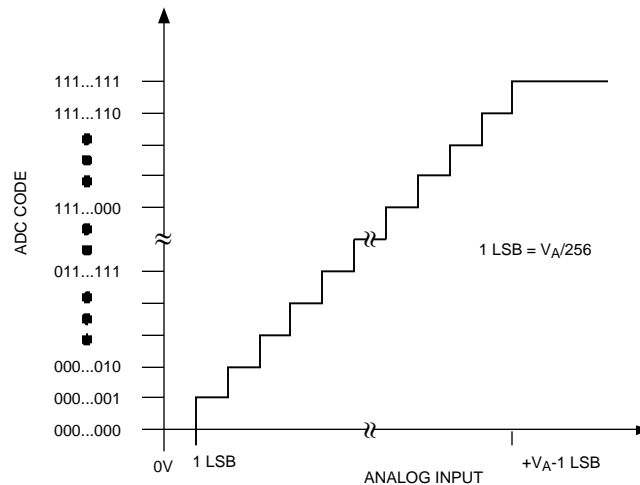

Figure 19. Track Mode

### 8.4.1 Transfer Function

The output format of the ADC is straight binary. Code transitions occur midway between successive integer LSB values. The LSB width for the ADC is  $V_A/256$ . The ideal transfer characteristic is shown in Figure 20. The transition from an output code of 0000 0000 to a code of 0000 0001 is at 1/2 LSB, or a voltage of  $V_A/512$ . Other code transitions occur at steps of one LSB.

## Device Functional Modes (continued)



**Figure 20. Ideal Transfer Characteristic**

### 8.4.2 Modes of Operation

The ADC has two possible modes of operation: normal mode and shutdown mode. The ADC enters normal mode (and a conversion process is begun) when  $\overline{CS}$  is pulled low. The device enters shutdown mode if  $\overline{CS}$  is pulled high before the tenth falling edge of SCLK after  $\overline{CS}$  is pulled low, or stays in normal mode if  $\overline{CS}$  remains low. Once in shutdown mode, the device stays there until  $\overline{CS}$  is brought low again. By varying the ratio of time spent in the normal and shutdown modes, a system may trade off throughput for power consumption, with a sample rate as low as zero.

#### 8.4.2.1 Normal Mode

The fastest possible throughput is obtained by leaving the ADC in normal mode at all times, so there are no power-up delays. To keep the device in normal mode continuously,  $\overline{CS}$  must be kept low until after the 10th falling edge of SCLK after the start of a conversion (remember that a conversion is initiated by bringing  $\overline{CS}$  low).

If  $\overline{CS}$  is brought high after the 10th falling edge, but before the 16th falling edge, the device remains in normal mode, but the current conversion is aborted and the SDATA returns to TRI-STATE (truncating the output word).

Sixteen SCLK cycles are required to read all of a conversion word from the device. After sixteen SCLK cycles have elapsed,  $\overline{CS}$  may be idled either high or low until the next conversion. If  $\overline{CS}$  is idled low, it must be brought high again before the start of the next conversion, which begins when  $\overline{CS}$  is again brought low.

After sixteen SCLK cycles, SDATA returns to TRI-STATE. Another conversion may be started, after  $t_{\text{QUIET}}$  has elapsed, by bringing  $\overline{CS}$  low again.

#### 8.4.2.2 Shutdown Mode

Shutdown mode is appropriate for applications that either do not sample continuously, or it is acceptable to trade throughput for power consumption. When the ADC is in shutdown mode, all of the analog circuitry is turned off.

To enter shutdown mode, a conversion must be interrupted by bringing  $\overline{CS}$  high anytime between the second and tenth falling edges of SCLK, as shown in [Figure 21](#). Once  $\overline{CS}$  has been brought high in this manner, the device enters shutdown mode, the current conversion is aborted and SDATA enters TRI-STATE. If  $\overline{CS}$  is brought high before the second falling edge of SCLK, the device does not change mode; this is to avoid accidentally changing mode as a result of noise on the  $\overline{CS}$  line.

Device Functional Modes (continued)

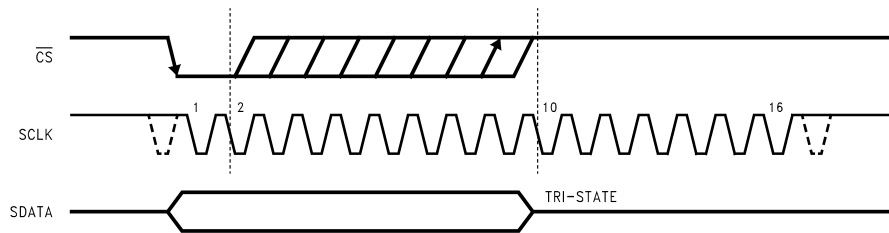

Figure 21. Entering Shutdown Mode

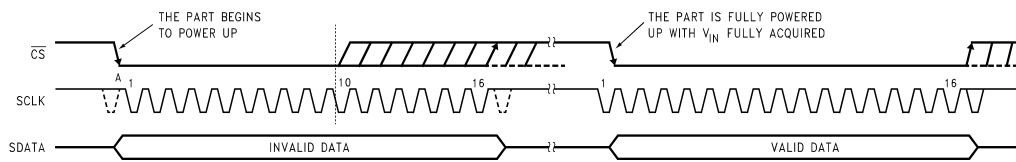

Figure 22. Entering Normal Mode

To exit shutdown mode, bring  $\overline{CS}$  back low. Upon bringing  $\overline{CS}$  low, the ADC begins powering up (power-up time is specified in [Timing Requirements](#)). This microsecond of power-up delay results in the first conversion result being unusable. The second conversion performed after power up, however, is valid, as shown in [Figure 22](#).

If  $\overline{CS}$  is brought back high before the 10th falling edge of SCLK, the device returns to shutdown mode. This is done to avoid accidentally entering normal mode as a result of noise on the  $\overline{CS}$  line. To exit shutdown mode and remain in normal mode,  $\overline{CS}$  must be kept low until after the 10th falling edge of SCLK. The ADC is fully powered up after 16 SCLK cycles.

## 9 Application and Implementation

### NOTE

Information in the following applications sections is not part of the TI component specification, and TI does not warrant its accuracy or completeness. TI's customers are responsible for determining suitability of components for their purposes. Customers should validate and test their design implementation to confirm system functionality.

### 9.1 Application Information

A typical application of the ADC is shown in [Typical Application](#). Power is provided in this example by the Texas Instruments LP2950 low-dropout voltage regulator (see *LP295x-N Series of Adjustable Micropower Voltage Regulators*, [SNVS764](#)), available in a variety of fixed and adjustable output voltages. The power supply pin is bypassed with a capacitor network placed close to the ADC. Because the reference for the ADC is the supply voltage, any noise on the supply degrades device noise performance. To keep noise off the supply, use a dedicated linear regulator for this device, or provide sufficient decoupling from other circuitry to keep noise off the ADC supply pin. Because of the ADC's low power requirements, it is also possible to use a precision reference as a power supply to maximize performance. The three-wire interface is shown connected to a microprocessor or DSP.

#### 9.1.1 Analog Inputs

An equivalent circuit for the ADC's input is shown in [Figure 23](#). Diodes D1 and D2 provide ESD protection for the analog inputs. At no time must the analog input go beyond ( $V_A + 300\text{ mV}$ ) or ( $\text{GND} - 300\text{ mV}$ ), as these ESD diodes begin to conduct, which could result in erratic operation. For this reason, the ESD diodes must not be used to clamp the input signal.

The capacitor C1 in [Figure 23](#) has a typical value of 4 pF, and is mainly the package pin capacitance. Resistor R1 is the ON resistance of the track or hold switch, and is typically 500  $\Omega$ . Capacitor C2 is the ADC sampling capacitor and is typically 26 pF. The ADC delivers best performance when driven by a low-impedance source to eliminate distortion caused by the charging of the sampling capacitance. This is especially important when using the ADC to sample AC signals. Also important when sampling dynamic signals is an anti-aliasing filter.

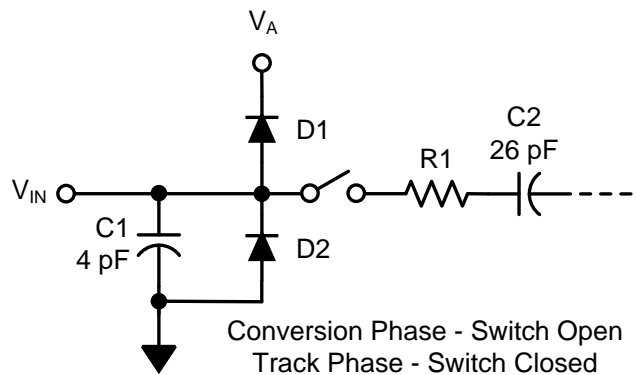

Copyright © 2016, Texas Instruments Incorporated

**Figure 23. Equivalent Input Circuit**

#### 9.1.2 Digital Inputs and Outputs

The ADC digital inputs (SCLK and  $\overline{CS}$ ) are not limited by the same maximum ratings as the analog inputs. The digital input pins are instead limited to 5.25 V with respect to GND, regardless of  $V_A$ , the supply voltage. This allows the ADC to be interfaced with a wide range of logic levels, independent of the supply voltage.

## 9.2 Typical Application

The ADC081S021 is a low-power, single-channel CMOS 8-bit analog-to-digital converter that uses the supply voltage as a reference, enabling the devices to operate with a full-scale input range of 0 to  $V_A$ . An example low power application with the LMT87 which is a wide range  $\pm 0.3^\circ\text{C}$  (typical) accurate temperature sensor is shown in Figure 24.

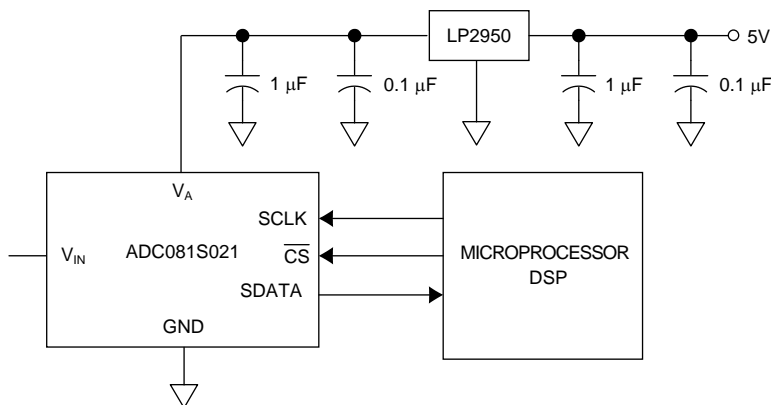

Copyright © 2016, Texas Instruments Incorporated

Figure 24. Typical Application Circuit

### 9.2.1 Design Requirements

A successful ADC081S021 and LMT87 design is constrained by the following factors:

- $V_{IN}$  range needs to be 0 V to  $V_A$  where  $V_A$  can range from 2.7 V to 5.25 V
- Output level of the LMT87 can range from 538 mV to 3277 mV (which satisfies the  $V_{IN}$  condition)

### 9.2.2 Detailed Design Procedure

Designing for an accurate measurement requires careful attention to timing requirements for the ADC081S021.

Because the ADC081S021 uses the supply voltage as a reference, it is important to make sure that the supply voltage is settled to its final level before exiting the shutdown mode and beginning a conversion. After the supply voltage is settled, the  $\overline{CS}$  is brought to a low level (ideally 0 V) to start a conversion.

It is also important to ensure that any noise on the power supply must be less than  $\frac{1}{2}$  LSB in amplitude. The supply voltage must be regarded as a precise voltage reference.

After the  $\overline{CS}$  is brought low, the user needs to wait for one complete conversion cycle (approximately 1  $\mu\text{s}$ ) for meaningful data. The dummy conversion cycle can be considered the start-up time of the ADC081S021.

The ADC081S021 digital output can then be correlated to the LMT87 output level to get an accurate temperature reading. At  $V_{DD} = 2.7$  V, 1 LSB of ADC081S021 is 10.54 mV. This information can be used to calculate the output level of LMT87 which can then be correlated to temperature.

**Typical Application (continued)**

**9.2.3 Application Curves**

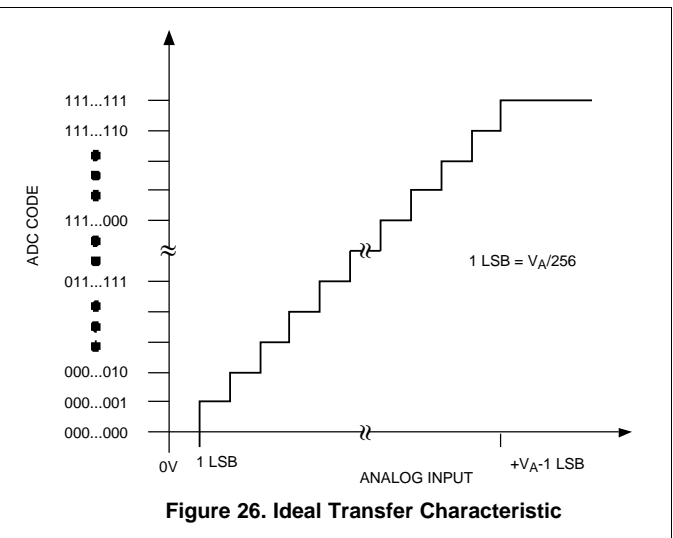
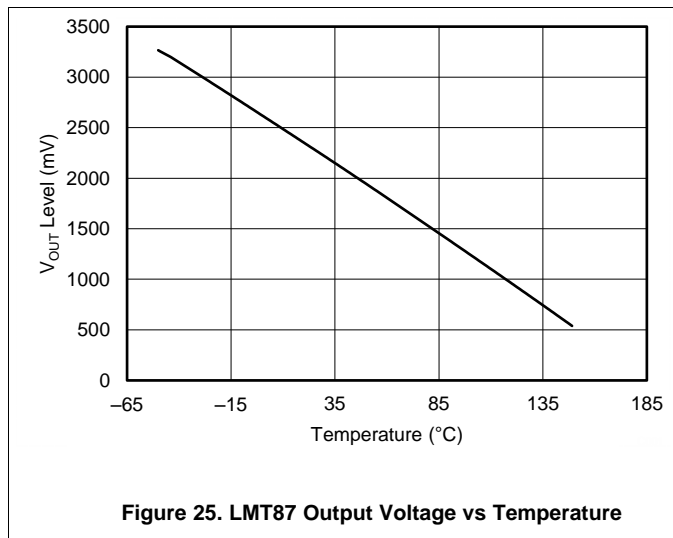

## 10 Power Supply Recommendations

The ADC takes time to power up, either after first applying  $V_A$ , or after returning to normal mode from shutdown mode. This corresponds to one *dummy* conversion for any SCLK frequency within the specifications in this document. After this first dummy conversion, the ADC performs conversions properly.

### NOTE

The  $t_{\text{QUIET}}$  time must still be included between the first dummy conversion and the second valid conversion.

When the  $V_A$  supply is first applied, the ADC may power up in either of the two modes: normal or shutdown. As such, one dummy conversion must be performed after start-up, as described in the previous paragraph. The part may then be placed into either normal mode or the shutdown mode, as described in [Normal Mode](#) and [Shutdown Mode](#).

When the ADC is operated continuously in normal mode, the maximum ensured throughput is  $f_{\text{SCLK}} / 20$  at the maximum specified  $f_{\text{SCLK}}$ . Throughput may be traded for power consumption by running  $f_{\text{SCLK}}$  at its maximum specified rate and performing fewer conversions per unit time, raising the ADC  $\overline{\text{CS}}$  line after the 10th and before the 15th fall of SCLK of each conversion. A plot of typical power consumption versus throughput is shown in [Typical Characteristics](#). To calculate the power consumption for a given throughput, multiply the fraction of time spent in the normal mode by the normal mode power consumption and add the fraction of time spent in shutdown mode multiplied by the shutdown mode power consumption. The curve of power consumption vs throughput ([Figure 17](#)) is essentially linear. This is because the power consumption in the shutdown mode is so small that it can be ignored for all practical purposes.

### 10.1 Noise Considerations

The charging of any output load capacitance requires current from the power supply,  $V_A$ . The current pulses required from the supply to charge the output capacitance causes voltage variations on the supply. If these variations are large enough, they could degrade SNR and SINAD performance of the ADC. Furthermore, discharging the output capacitance when the digital output goes from a logic high to a logic low dumps current into the die substrate, which is resistive. Load discharge currents cause *ground bounce* noise in the substrate that degrades noise performance if that current is large enough. The larger the output capacitance, the more current flows through the die substrate and the greater is the noise coupled into the analog channel, degrading noise performance.

To keep noise out of the power supply, keep the output load capacitance as small as practical. It is good practice to use a 100- $\Omega$  series resistor at the ADC output, placed as close to the ADC output pin as practical. This limits the charge and discharge current of the output capacitance and maintain noise performance.

## 11 Layout

### 11.1 Layout Guidelines

Capacitive coupling between noisy digital circuitry and sensitive analog circuitry can lead to poor performance. TI strongly recommends keeping the analog and digital circuitry separated from each other and the clock line as short as possible.

Digital circuits create substantial supply and ground current transients. This digital noise could have significant impact upon system noise performance. To avoid performance degradation due to supply noise, do not use the same supply for the ADC081S021 that is used for digital logic.

Generally, analog and digital lines must cross each other at 90° to avoid crosstalk. However, to maximize accuracy in high resolution systems, avoid crossing analog and digital lines altogether. It is important to keep clock lines as short as possible and isolated from ALL other lines, including other digital lines. In addition, the clock line must also be treated as a transmission line and be properly terminated.

The analog input must be isolated from noisy signal lines to avoid coupling of spurious signals into the input. Any external component (that is, a filter capacitor) connected between the converter's input pins and ground or to the reference input pin and ground must be connected to a very clean point in the ground plane.

## Layout Guidelines (continued)

TI recommends the use of a single, uniform ground plane and the use of split power planes. The power planes must be placed within the same board layer. All analog circuitry (input amplifiers, filters, reference components, and so on) must be placed over the analog power plane. All digital circuitry and I/O lines must be placed over the digital power plane. In addition, all components in the reference circuitry and the input signal chain that are connected to ground must be connected together with short traces and enter the analog ground plane at a single, quiet point.

### 11.2 Layout Example

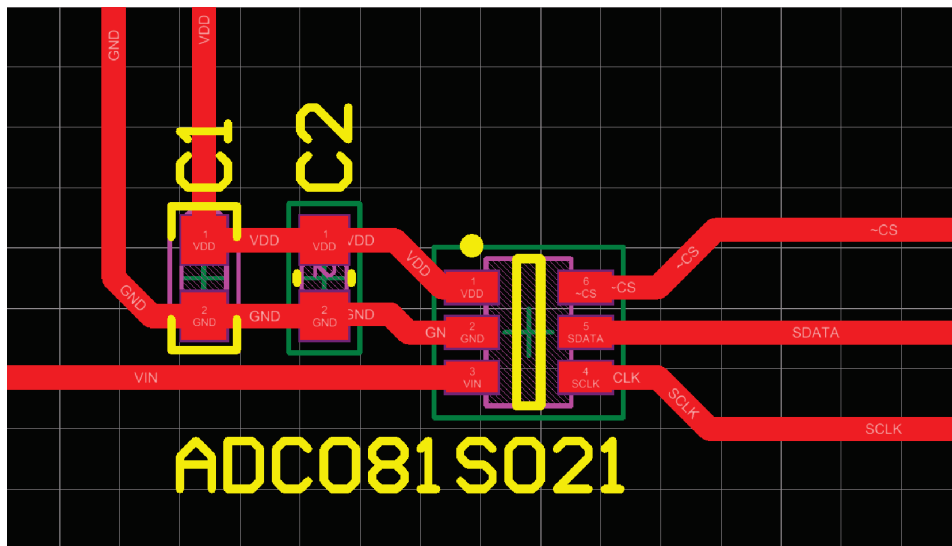

Figure 27. DBV Package Layout

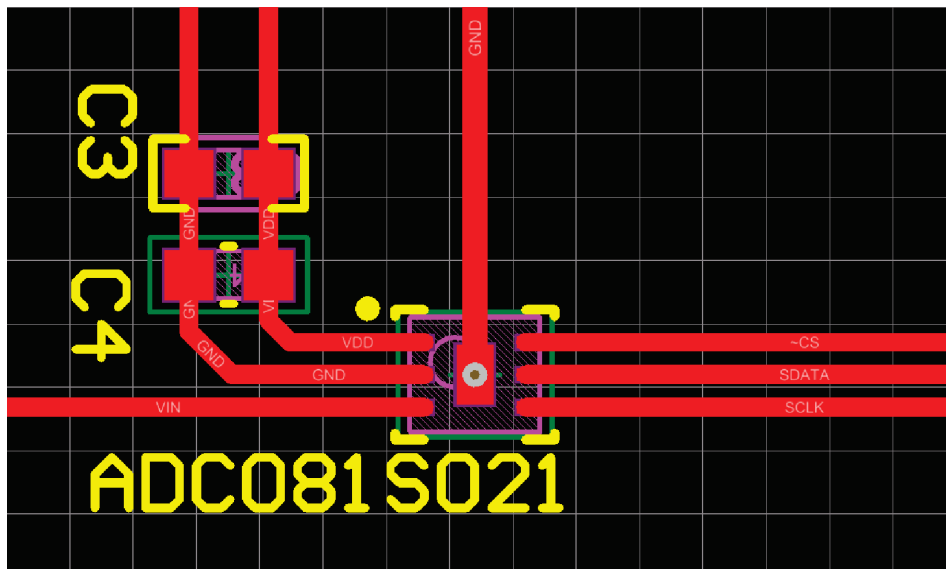

Figure 28. NGF Package Layout

## 12 Device and Documentation Support

### 12.1 Device Support

#### 12.1.1 Device Nomenclature

**ACQUISITION TIME** is the time required to acquire the input voltage. That is, it is time required for the hold capacitor to charge up to the input voltage. Acquisition time is measured backwards from the falling edge of  $\overline{CS}$  when the signal is sampled and the part moves from track to hold. The start of the time interval that contains  $T_{ACQ}$  is the 13th rising edge of SCLK of the previous conversion when the part moves from hold to track. The user must ensure that the time between the 13th rising edge of SCLK and the falling edge of the next  $\overline{CS}$  is not less than  $T_{ACQ}$  to meet performance specifications.

**APERTURE DELAY** is the time after the falling edge of  $\overline{CS}$  when the input signal is acquired or held for conversion.

**APERTURE JITTER (APERTURE UNCERTAINTY)** is the variation in aperture delay from sample to sample. Aperture jitter manifests itself as noise in the output.

**CONVERSION TIME** is the time required, after the input voltage is acquired, for the ADC081S021 to convert the input voltage to a digital word. This is from the falling edge of  $\overline{CS}$  when the input signal is sampled to the 16th falling edge of SCLK when the SDATA output goes into TRI-STATE.

**DIFFERENTIAL NON-LINEARITY (DNL)** is the measure of the maximum deviation from the ideal step size of 1 LSB.

**DUTY CYCLE** is the ratio of the time that a repetitive digital waveform is high to the total time of one period. The specification here refers to the SCLK.

**EFFECTIVE NUMBER OF BITS (ENOB, or EFFECTIVE BITS)** is another method of specifying Signal-to-Noise and Distortion or SINAD. ENOB is defined as  $(SINAD - 1.76) / 6.02$  and says that the converter is equivalent to a perfect ADC081S021 of this (ENOB) number of bits.

**FULL POWER BANDWIDTH** is a measure of the frequency at which the reconstructed output fundamental drops 3 dB below its low frequency value for a full scale input.

**GAIN ERROR** is the deviation of the last code transition (111...110) to (111...111) from the ideal ( $V_{REF} - 1$  LSB), after adjusting for offset error.

**INTEGRAL NON-LINEARITY (INL)** is a measure of the deviation of each individual code from a line drawn from negative full scale ( $\frac{1}{2}$  LSB below the first code transition) through positive full scale ( $\frac{1}{2}$  LSB above the last code transition). The deviation of any given code from this straight line is measured from the center of that code value.

**INTERMODULATION DISTORTION (IMD)** is the creation of additional spectral components as a result of two sinusoidal frequencies being applied to the ADC081S021 input at the same time. It is defined as the ratio of the power in the second and third order intermodulation products to the sum of the power in both of the original frequencies. IMD is usually expressed in dB.

**MISSING CODES** are those output codes that never appear at the ADC081S021 outputs. The ADC081S021 is ensured not to have any missing codes.

**OFFSET ERROR** is the deviation of the first code transition (000...000) to (000...001) from the ideal (that is,  $GND + 1$  LSB).

**SIGNAL TO NOISE RATIO (SNR)** is the ratio, expressed in dB, of the RMS value of the input signal to the RMS value of the sum of all other spectral components below one-half the sampling frequency, not including harmonics or DC

**SIGNAL TO NOISE PLUS DISTORTION (S/N+D or SINAD)** Is the ratio, expressed in dB, of the RMS value of the input signal to the RMS value of all of the other spectral components below half the clock frequency, including harmonics but excluding DC

## Device Support (continued)

**SPURIOUS FREE DYNAMIC RANGE (SFDR)** is the difference, expressed in dB, between the desired signal amplitude to the amplitude of the peak spurious spectral component, where a spurious spectral component is any signal present in the output spectrum that is not present at the input and may or may not be a harmonic.

**TOTAL HARMONIC DISTORTION (THD)** is the ratio, expressed in dB or dBc, of the RMS total of the first five harmonic components at the output to the RMS level of the input signal frequency as seen at the

$$\text{THD} = 20 \cdot \log_{10} \sqrt{\frac{A_{f_2}^2 + \dots + A_{f_6}^2}{A_{f_1}^2}}$$

output. THD is calculated as the input frequency at the output and  $A_{f_2}$  through  $A_{f_6}$  are the RMS power in the first 5 harmonic frequencies.

where  $A_{f_1}$  is the RMS power of

the input frequency at the output and  $A_{f_2}$  through  $A_{f_6}$  are the RMS power in the first 5 harmonic frequencies.

**THROUGHPUT TIME** is the minimum time required between the start of two successive conversion. It is the acquisition time plus the conversion time.

**TOTAL UNADJUSTED ERROR** is the worst deviation found from the ideal transfer function. As such, it is a comprehensive specification which includes full scale error, linearity error, and offset error.

## 12.2 Documentation Support

### 12.2.1 Related Documentation

For related documentation see the following:

*LP295x-N Series of Adjustable Micropower Voltage Regulators*, [SNVS764](#)

## 12.3 Community Resources

The following links connect to TI community resources. Linked contents are provided "AS IS" by the respective contributors. They do not constitute TI specifications and do not necessarily reflect TI's views; see TI's [Terms of Use](#).

**TI E2E™ Online Community** *TI's Engineer-to-Engineer (E2E) Community*. Created to foster collaboration among engineers. At [e2e.ti.com](http://e2e.ti.com), you can ask questions, share knowledge, explore ideas and help solve problems with fellow engineers.

**Design Support** *TI's Design Support* Quickly find helpful E2E forums along with design support tools and contact information for technical support.

## 12.4 Trademarks

SPI, QSPI, MICROWIRE, E2E are trademarks of Texas Instruments. All other trademarks are the property of their respective owners.

## 12.5 Electrostatic Discharge Caution



These devices have limited built-in ESD protection. The leads should be shorted together or the device placed in conductive foam during storage or handling to prevent electrostatic damage to the MOS gates.

## 12.6 Glossary

[SLYZ022](#) — *TI Glossary*.

This glossary lists and explains terms, acronyms, and definitions.

## 13 Mechanical, Packaging, and Orderable Information

The following pages include mechanical, packaging, and orderable information. This information is the most current data available for the designated devices. This data is subject to change without notice and revision of this document. For browser-based versions of this data sheet, refer to the left-hand navigation.

## PACKAGING INFORMATION

Orderable Device	Status (1)	Package Type	Package Drawing	Pins	Package Qty	Eco Plan (2)	Lead finish/ Ball material (6)	MSL Peak Temp (3)	Op Temp (°C)	Device Marking (4/5)	Samples
ADC081S021CIMF	NRND	SOT-23	DBV	6	1000	Non-RoHS & Green	Call TI	Level-1-260C-UNLIM	-40 to 85	X09C	
ADC081S021CIMF/NOPB	ACTIVE	SOT-23	DBV	6	1000	RoHS & Green	SN	Level-1-260C-UNLIM	-40 to 85	X09C	<a href="#">Samples</a>
ADC081S021CIMFX/NOPB	ACTIVE	SOT-23	DBV	6	3000	RoHS & Green	SN	Level-1-260C-UNLIM	-40 to 85	X09C	<a href="#">Samples</a>
ADC081S021CISD/NOPB	ACTIVE	WSON	NGF	6	1000	RoHS & Green	SN	Level-1-260C-UNLIM	-40 to 85	X9C	<a href="#">Samples</a>

(1) The marketing status values are defined as follows:

**ACTIVE:** Product device recommended for new designs.

**LIFEBUY:** TI has announced that the device will be discontinued, and a lifetime-buy period is in effect.

**NRND:** Not recommended for new designs. Device is in production to support existing customers, but TI does not recommend using this part in a new design.

**PREVIEW:** Device has been announced but is not in production. Samples may or may not be available.

**OBSELETE:** TI has discontinued the production of the device.

(2) **RoHS:** TI defines "RoHS" to mean semiconductor products that are compliant with the current EU RoHS requirements for all 10 RoHS substances, including the requirement that RoHS substance do not exceed 0.1% by weight in homogeneous materials. Where designed to be soldered at high temperatures, "RoHS" products are suitable for use in specified lead-free processes. TI may reference these types of products as "Pb-Free".

**RoHS Exempt:** TI defines "RoHS Exempt" to mean products that contain lead but are compliant with EU RoHS pursuant to a specific EU RoHS exemption.

**Green:** TI defines "Green" to mean the content of Chlorine (Cl) and Bromine (Br) based flame retardants meet JS709B low halogen requirements of <=1000ppm threshold. Antimony trioxide based flame retardants must also meet the <=1000ppm threshold requirement.

(3) MSL, Peak Temp. - The Moisture Sensitivity Level rating according to the JEDEC industry standard classifications, and peak solder temperature.

(4) There may be additional marking, which relates to the logo, the lot trace code information, or the environmental category on the device.

(5) Multiple Device Markings will be inside parentheses. Only one Device Marking contained in parentheses and separated by a "~" will appear on a device. If a line is indented then it is a continuation of the previous line and the two combined represent the entire Device Marking for that device.

(6) Lead finish/Ball material - Orderable Devices may have multiple material finish options. Finish options are separated by a vertical ruled line. Lead finish/Ball material values may wrap to two lines if the finish value exceeds the maximum column width.

**Important Information and Disclaimer:**The information provided on this page represents TI's knowledge and belief as of the date that it is provided. TI bases its knowledge and belief on information provided by third parties, and makes no representation or warranty as to the accuracy of such information. Efforts are underway to better integrate information from third parties. TI has taken and

continues to take reasonable steps to provide representative and accurate information but may not have conducted destructive testing or chemical analysis on incoming materials and chemicals. TI and TI suppliers consider certain information to be proprietary, and thus CAS numbers and other limited information may not be available for release.

In no event shall TI's liability arising out of such information exceed the total purchase price of the TI part(s) at issue in this document sold by TI to Customer on an annual basis.

**TAPE AND REEL INFORMATION**

**QUADRANT ASSIGNMENTS FOR PIN 1 ORIENTATION IN TAPE**

\*All dimensions are nominal

Device	Package Type	Package Drawing	Pins	SPQ	Reel Diameter (mm)	Reel Width W1 (mm)	A0 (mm)	B0 (mm)	K0 (mm)	P1 (mm)	W (mm)	Pin1 Quadrant
ADC081S021CIMF	SOT-23	DBV	6	1000	178.0	8.4	3.2	3.2	1.4	4.0	8.0	Q3
ADC081S021CIMF/NOPB	SOT-23	DBV	6	1000	178.0	8.4	3.2	3.2	1.4	4.0	8.0	Q3
ADC081S021CIMFX/NOPB	SOT-23	DBV	6	3000	178.0	8.4	3.2	3.2	1.4	4.0	8.0	Q3
ADC081S021CISD/NOPB	WSON	NGF	6	1000	178.0	12.4	2.8	2.5	1.0	8.0	12.0	Q1

## TAPE AND REEL BOX DIMENSIONS



\*All dimensions are nominal

Device	Package Type	Package Drawing	Pins	SPQ	Length (mm)	Width (mm)	Height (mm)
ADC081S021CIMF	SOT-23	DBV	6	1000	210.0	185.0	35.0
ADC081S021CIMF/NOPB	SOT-23	DBV	6	1000	210.0	185.0	35.0
ADC081S021CIMFX/NOPB	SOT-23	DBV	6	3000	210.0	185.0	35.0
ADC081S021CISD/NOPB	WSON	NGF	6	1000	210.0	185.0	35.0

DBV0006A



# PACKAGE OUTLINE

SOT-23 - 1.45 mm max height

SMALL OUTLINE TRANSISTOR

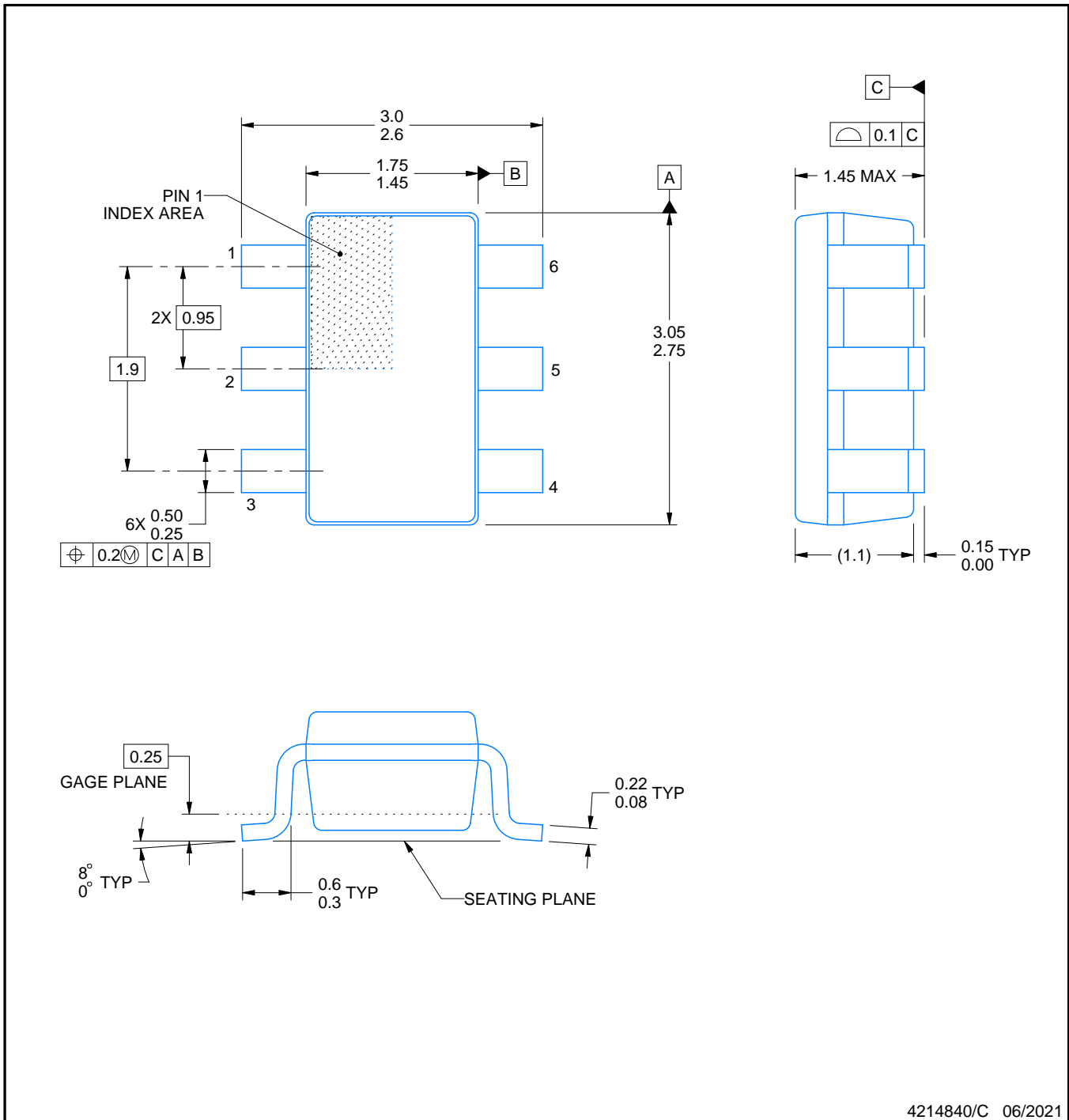

4214840/C 06/2021

## NOTES:

1. All linear dimensions are in millimeters. Any dimensions in parenthesis are for reference only. Dimensioning and tolerancing per ASME Y14.5M.
2. This drawing is subject to change without notice.
3. Body dimensions do not include mold flash or protrusion. Mold flash and protrusion shall not exceed 0.25 per side.
4. Leads 1,2,3 may be wider than leads 4,5,6 for package orientation.
5. Reference JEDEC MO-178.

# EXAMPLE BOARD LAYOUT

DBV0006A

SOT-23 - 1.45 mm max height

SMALL OUTLINE TRANSISTOR

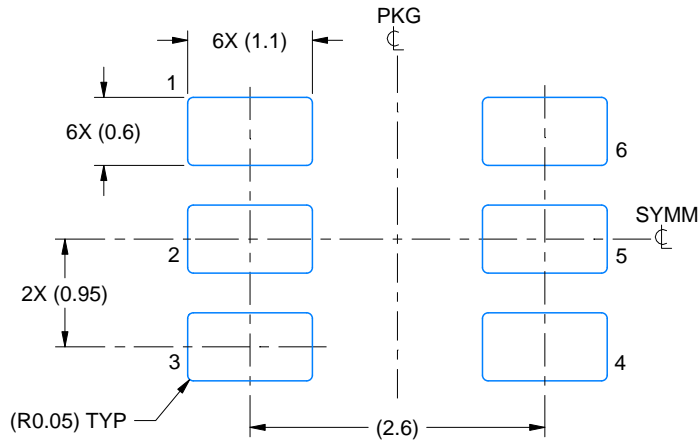

LAND PATTERN EXAMPLE  
EXPOSED METAL SHOWN  
SCALE:15X

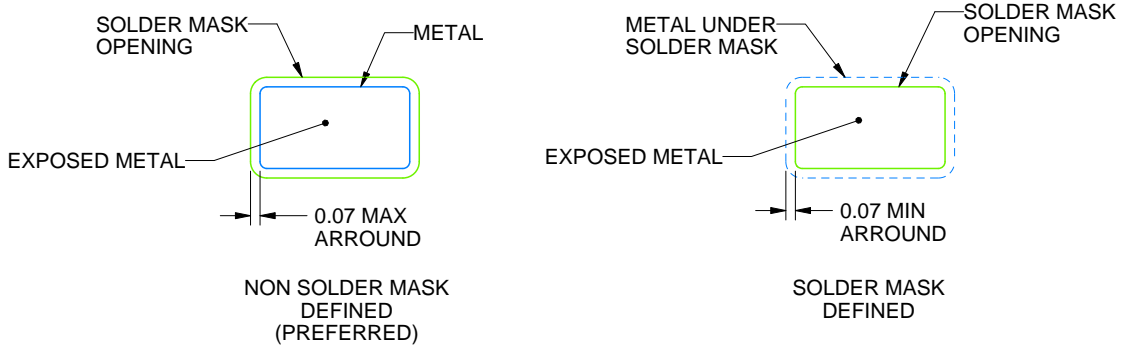

SOLDER MASK DETAILS

4214840/C 06/2021

NOTES: (continued)

- 6. Publication IPC-7351 may have alternate designs.
- 7. Solder mask tolerances between and around signal pads can vary based on board fabrication site.

# EXAMPLE STENCIL DESIGN

DBV0006A

SOT-23 - 1.45 mm max height

SMALL OUTLINE TRANSISTOR

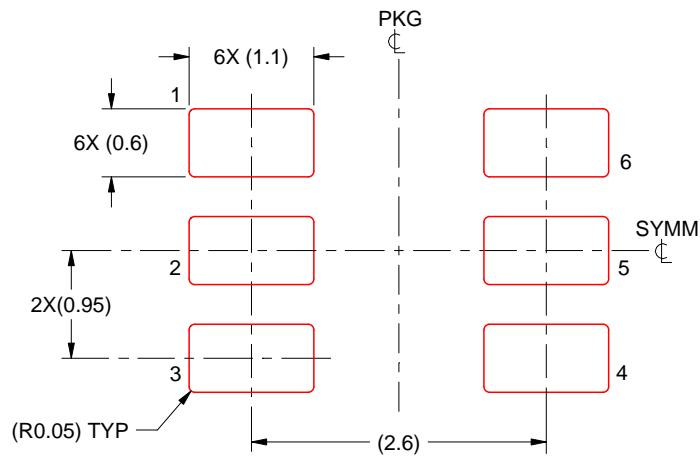

SOLDER PASTE EXAMPLE  
BASED ON 0.125 mm THICK STENCIL  
SCALE:15X

4214840/C 06/2021

NOTES: (continued)

8. Laser cutting apertures with trapezoidal walls and rounded corners may offer better paste release. IPC-7525 may have alternate design recommendations.
9. Board assembly site may have different recommendations for stencil design.

NGF0006A

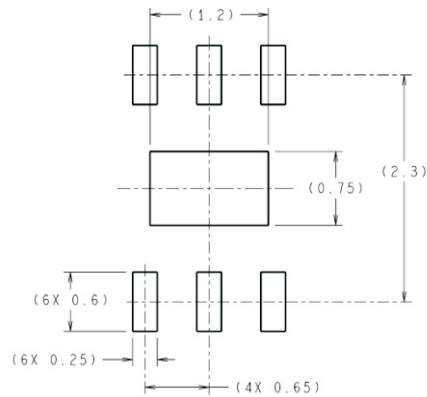

DIMENSIONS ARE IN MILLIMETERS  
DIMENSIONS IN ( ) FOR REFERENCE ONLY

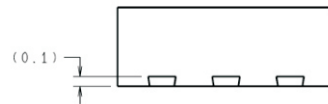

RECOMMENDED LAND PATTERN

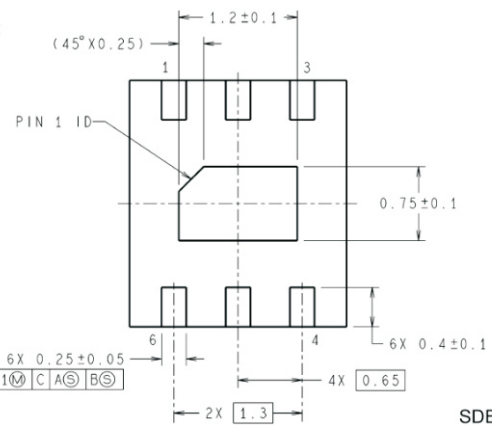
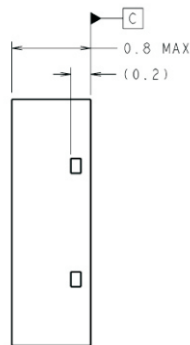
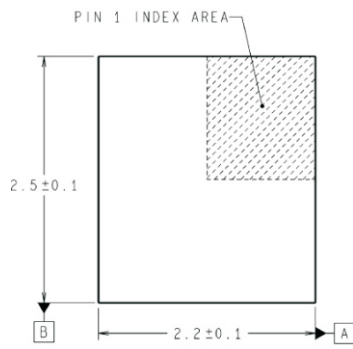

SDB06A (Rev A)

## IMPORTANT NOTICE AND DISCLAIMER

TI PROVIDES TECHNICAL AND RELIABILITY DATA (INCLUDING DATASHEETS), DESIGN RESOURCES (INCLUDING REFERENCE DESIGNS), APPLICATION OR OTHER DESIGN ADVICE, WEB TOOLS, SAFETY INFORMATION, AND OTHER RESOURCES "AS IS" AND WITH ALL FAULTS, AND DISCLAIMS ALL WARRANTIES, EXPRESS AND IMPLIED, INCLUDING WITHOUT LIMITATION ANY IMPLIED WARRANTIES OF MERCHANTABILITY, FITNESS FOR A PARTICULAR PURPOSE OR NON-INFRINGEMENT OF THIRD PARTY INTELLECTUAL PROPERTY RIGHTS.

These resources are intended for skilled developers designing with TI products. You are solely responsible for (1) selecting the appropriate TI products for your application, (2) designing, validating and testing your application, and (3) ensuring your application meets applicable standards, and any other safety, security, or other requirements. These resources are subject to change without notice. TI grants you permission to use these resources only for development of an application that uses the TI products described in the resource. Other reproduction and display of these resources is prohibited. No license is granted to any other TI intellectual property right or to any third party intellectual property right. TI disclaims responsibility for, and you will fully indemnify TI and its representatives against, any claims, damages, costs, losses, and liabilities arising out of your use of these resources.

TI's products are provided subject to TI's Terms of Sale (<https://www.ti.com/legal/termsofsale.html>) or other applicable terms available either on [ti.com](https://www.ti.com) or provided in conjunction with such TI products. TI's provision of these resources does not expand or otherwise alter TI's applicable warranties or warranty disclaimers for TI products.

Mailing Address: Texas Instruments, Post Office Box 655303, Dallas, Texas 75265  
Copyright © 2021, Texas Instruments Incorporated