

# 适用于电感感应的 LDC1312、LDC1314 多通道 12 位电感数字转换器 (LDC)

## 1 特性

- 易于使用 – 配置要求极低
- 多达 4 个具有匹配传感器驱动器的通道
- 多个通道支持环境和老化补偿
- 大于 20cm 的远程传感器位置支持在严苛的环境下运行
- 与中等分辨率和高分辨率选项引脚兼容：
  - LDC1312/4: 2/4 通道 12 位 LDC
  - LDC1612/4: 2/4 通道 28 位 LDC
- 支持 1kHz 至 10MHz 的宽传感器频率范围
- 功耗：
  - 35 $\mu$ A (低功耗休眠模式)
  - 200nA (关断模式)
- 2.7V 至 3.6V 工作电压
- 多个基准时钟选项：
  - 包含内部时钟，以降低系统成本
  - 支持 40MHz 外部时钟，以提高系统性能
- 抗直流磁场和磁体干扰

## 2 应用

- 消费类产品、电器和汽车中的旋钮
- 线性和旋转编码器
- 家用电子产品、可穿戴设备、制造业和汽车中的按钮
- 制造业和电器中的键盘
- 消费类产品中的滑动按钮
- 工业和汽车中的金属探测
- POS 和 EPOS
- 消费类产品和电器中的流量计  
简化原理图

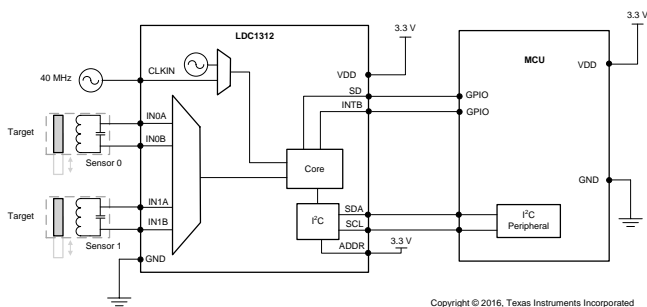

## 3 说明

LDC1312 和 LDC1314 分别是用于电感感测解决方案的 2 通道和 4 通道 12 位电感数字转换器 (LDC)。由于具备多通道且支持远程感测，LDC1312 和 LDC1314 能以最低的成本和功耗实现高性能且可靠的电感感测。此类产品使用简便，仅需要传感器频率处于 1kHz 至 10MHz 的范围内即可开始工作。由于支持的传感器频率范围 1kHz 至 10MHz 较宽，因此还支持使用非常小的 PCB 线圈，从而进一步降低感测解决方案的成本和尺寸。

LDC1312 和 LDC1314 提供匹配良好的通道，可实现差分测量与比率测量。因此，设计人员能够利用一个通道来补偿感测过程中的环境条件和老化条件，例如温度、湿度和机械漂移。得益于易用、低能耗、低系统成本等特性，这些产品有助于设计人员大幅提高现有传感解决方案的性能、可靠性和灵活性，并将全新的传感功能引入到了所有市场（尤其是消费品和工业应用）中的产品。相比同类感测技术，电感感测具有更高的性能、可靠性和灵活性，而且系统成本与功耗更低。

LDC1312 和 LDC1314 能够通过 I2C 接口轻松进行配置。双通道 LDC1312 采用 WSON-12 封装，四通道 LDC1314 采用 WQFN-16 封装。

器件信息<sup>(1)</sup>

器件型号	封装	封装尺寸 (标称值)
LDC1312	WSON-12	4mm x 4mm
LDC1314	WQFN-16	4mm x 4mm

(1) 如需了解所有可用封装，请见数据表末尾的可订购产品附录。

测量精度与目标距离间的关系

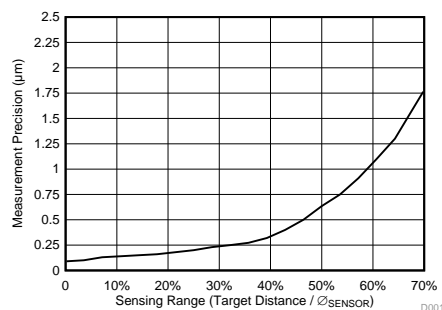

## 目录

1	特性 .....	1	7.6	Register Maps .....	14
2	应用 .....	1	<b>8</b>	<b>Application and Implementation</b> .....	<b>31</b>
3	说明 .....	1	8.1	Application Information .....	31
4	修订历史记录 .....	2	8.2	Typical Application .....	47
<b>5</b>	<b>Pin Configuration and Functions</b> .....	<b>3</b>	<b>9</b>	<b>Power Supply Recommendations</b> .....	<b>51</b>
<b>6</b>	<b>Specifications</b> .....	<b>4</b>	<b>10</b>	<b>Layout</b> .....	<b>52</b>
6.1	Absolute Maximum Ratings .....	4	10.1	Layout Guidelines .....	52
6.2	ESD Ratings .....	4	10.2	Layout Example .....	52
6.3	Recommended Operating Conditions .....	4	<b>11</b>	<b>器件和文档支持</b> .....	<b>53</b>
6.4	Thermal Information .....	4	11.1	器件支持 .....	53
6.5	Electrical Characteristics .....	5	11.2	文档支持 .....	53
6.6	Switching Characteristics - I2C .....	6	11.3	相关链接 .....	53
6.7	Typical Characteristics .....	7	11.4	接收文档更新通知 .....	53
<b>7</b>	<b>Detailed Description</b> .....	<b>9</b>	11.5	社区资源 .....	53
7.1	Overview .....	9	11.6	商标 .....	53
7.2	Functional Block Diagram .....	9	11.7	静电放电警告 .....	54
7.3	Feature Description .....	9	11.8	Glossary .....	54
7.4	Device Functional Modes .....	11	<b>12</b>	<b>机械、封装和可订购信息</b> .....	<b>54</b>
7.5	Programming .....	12			

## 4 修订历史记录

注：之前版本的页码可能与当前版本有所不同。

<b>Changes from Original (December 2014) to Revision A</b>	<b>Page</b>
• Changed ESD values from 1000 to 2000 and from 250 to 750 on both packages .....	4
• Added logic levels for ADDR, INTB, and SD pins .....	5
• Changed description of clocking architecture for improved clarity. ....	10
• Changed register names and field names from CHx_NAME and NAME_CHx to NAMEx. ....	14
• Added instructions on setting registers with both R and R/W fields .....	14
• Changed register names from DATA_CHx to DATAx; and CHx_ERR_YY field names to ERR_YYx. ....	15
• Changed ERR_AE field description on DATA0, DATA1, DATA2 and DATA3 tables. ....	15
• Changed register names from RCOUNT_CHx to RCOUNTx; and CHx_RCOUNT field names to RCOUNTx .....	17
• Changed register names from OFFSET_CHx to OFFSETx; and CHx_OFFSET field names to OFFSETx .....	18
• Changed register names from SETTLECOUNT_CHx to SETTLECOUNTx; and CHx_SETTLECOUNT field names to SETTLECOUNTx .....	19
• Changed Address of SETTLECOUNT0 and SETTLECOUNT1 were not correct on table. ....	20
• Changed register names from CLOCK_DIVIDERS_CHx to CLOCK_DIVIDERSx; CHx_FIN_DIVIDER field names to FIN_DIVIDERx, and CHx_FREF_DIVIDER field names to FREF_DIVIDERx. ....	21
• Changed CHx_UNREADCONV field names to UNREADCONVx .....	23
• Changed register names from DRIVE_CURRENT_CHx to DRIVE_CURRENTx; CHx_IDRIVE field names to IDRIVEx, and CHx_INIT_IDRIVE to INIT_IDRIVEx .....	28
• Changed Application Information section for clarity, and provided additional information on device configuration and operation. ....	31
• Added instructions for using an oscilloscope to configure sensor drive current .....	42
• Changed description of clocking usage for clarity. ....	43
• Changed reference frequency limits from < to ≤ .....	44
• Changed to a ≥ symbol in the <i>Clock Configuration Requirements</i> table. ....	44

## 5 Pin Configuration and Functions

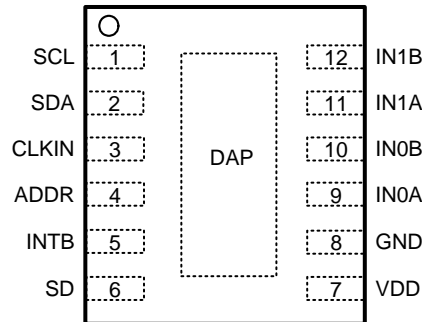
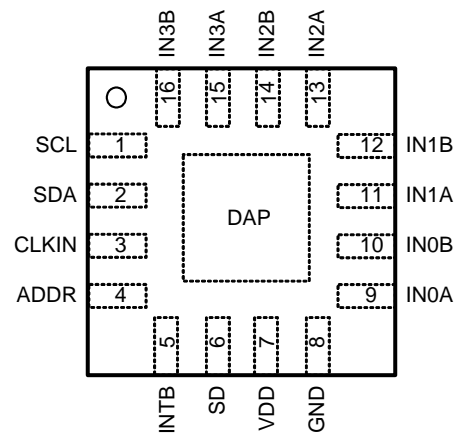
**DNT and RGH Packages  
Top View**

**LDC1312 WSON-12**

**LDC1314 WQFN-16**

### Pin Functions

PIN		TYPE <sup>(1)</sup>	DESCRIPTION
NAME	NO.		
SCL	1	I	I2C Clock input. Open drain output; requires resistive pullup to logic high level.
SDA	2	I/O	I2C Data input/output. Open drain output; requires resistive pullup to logic high level.
CLKIN	3	I	External Reference Clock input. Tie this pin to GND if internal oscillator is used.
ADDR	4	I	I2C Address selection pin: when ADDR=L, I2C address = 0x2A, when ADDR=H, I2C address = 0x2B. This input must not be allowed to float.
INTB	5	O	Configurable Interrupt output pin. Push-pull output; does not require pullup.
SD	6	I	Shutdown input: set SD = L for normal operation, set SD=H for inactive mode. This input must not be allowed to float.
VDD	7	P	Power Supply
GND	8	G	Ground
IN0A	9	A	External LC sensor 0 connection
IN0B	10	A	External LC sensor 0 connection
IN1A	11	A	External LC sensor 1 connection
IN1B	12	A	External LC sensor 1 connection
IN2A	13	A	External LC sensor 2 connection (LDC1314 only)
IN2B	14	A	External LC sensor 2 connection (LDC1314 only)
IN3A	15	A	External LC sensor 3 connection (LDC1314 only)
IN3B	16	A	External LC sensor 3 connection (LDC1314 only)
DAP <sup>(2)</sup>	DAP	N/A	Connect to Ground

(1) I = Input, O = Output, P=Power, G=Ground, A=Analog

(2) There is an internal electrical connection between the exposed Die Attach Pad (DAP) and the GND pin of the device. Although the DAP can be left floating, for best performance the DAP should be connected to the same potential as the device's GND pin. Do not use the DAP as the primary ground for the device. The device GND pin must always be connected to ground.

## 6 Specifications

### 6.1 Absolute Maximum Ratings

		MIN	MAX	UNIT
$V_{DD}$	Supply Voltage Range		5	V
$V_i$	Voltage on any pin	-0.3	$V_{DD}+0.3$	V
$I_A$	Input current on any INx pin	-8	8	mA
$I_D$	Input current on any Digital pin	-5	5	mA
$T_j$	Junction Temperature	-55	150	°C
$T_{stg}$	Storage temperature range	-65	150	°C

- (1) Stresses beyond those listed under *Absolute Maximum Ratings* may cause permanent damage to the device. These are stress ratings only, which do not imply functional operation of the device at these or any other conditions beyond those indicated under *Recommended Operating Conditions*. Exposure to absolute-maximum-rated conditions for extended periods may affect device reliability.

### 6.2 ESD Ratings

		VALUE	UNIT
LDC1312 in WSON-12 package			
$V_{(ESD)}$	Electrostatic discharge	Human-body model (HBM), per ANSI/ESDA/JEDEC JS-001 <sup>(1)</sup>	±2000
		Charged-device model (CDM), per JEDEC specification JESD22-C101 <sup>(2)</sup>	±750
LDC1314 in WQFN-16 package			
$V_{(ESD)}$	Electrostatic discharge	Human-body model (HBM), per ANSI/ESDA/JEDEC JS-001 <sup>(1)</sup>	±2000
		Charged-device model (CDM), per JEDEC specification JESD22-C101 <sup>(2)</sup>	±750

- (1) JEDEC document JEP155 states that 500-V HBM allows safe manufacturing with a standard ESD control process.  
 (2) JEDEC document JEP157 states that 250-V CDM allows safe manufacturing with a standard ESD control process.

### 6.3 Recommended Operating Conditions

Unless otherwise specified, all limits ensured for  $T_A = 25^\circ\text{C}$ ,  $V_{DD} = 3.3\text{ V}$

		MIN	NOM	MAX	UNIT
$V_{DD}$	Supply Voltage	2.7		3.6	V
$T_A$	Operating Temperature	-40		125	°C

### 6.4 Thermal Information

THERMAL METRIC <sup>(1)</sup>		LDC1312	LDC1314	UNIT
		WSON (DNT)	WQFN (RGH)	
		12 PINS	16 PINS	
$R_{\theta JA}$	Junction-to-ambient thermal resistance	50	38	°C/W

- (1) For more information about traditional and new thermal metrics, see the [Semiconductor and IC Package Thermal Metrics](#) application report.

## 6.5 Electrical Characteristics

Unless otherwise specified, all limits ensured for  $T_A = 25^\circ\text{C}$ ,  $V_{DD} = 3.3\text{ V}$ . See <sup>(1)</sup>

PARAMETER	TEST CONDITIONS <sup>(2)</sup>	MIN <sup>(3)</sup>	TYP <sup>(4)</sup>	MAX <sup>(3)</sup>	UNIT	
<b>POWER</b>						
$V_{DD}$	Supply Voltage	$T_A = -40^\circ\text{C}$ to $+125^\circ\text{C}$		2.7	3.6	V
$I_{DD}$	Supply Current (not including sensor current) <sup>(5)</sup>	$f_{CLKIN} = 10\text{ MHz}$ <sup>(6)</sup>		2.1		mA
$I_{DDSL}$	Sleep Mode Supply Current <sup>(5)</sup>	SLEEP_MODE_EN = b1		35	60	$\mu\text{A}$
$I_{SD}$	Shutdown Mode Supply Current <sup>(5)</sup>	SD = $V_{DD}$		0.2	1	$\mu\text{A}$
<b>SENSOR</b>						
$I_{SENSORMAX}$	Sensor Maximum Current drive	HIGH_CURRENT_DRV = b0 DRIVE_CURRENTx = 0xF800		1.5		mA
$R_P$	Sensor $R_P$			1	100	k $\Omega$
$I_{HDSENSORMAX}$	High current sensor drive mode: Sensor Maximum Current	HIGH_CURRENT_DRV = b1 DRIVE_CURRENT0 = 0xF800 Channel 0 only		6		mA
$R_{P\_HD\_MIN}$	Minimum sensor $R_P$			250		$\Omega$
$f_{SENSOR}$	Sensor Resonance Frequency	$T_A = -40^\circ\text{C}$ to $+125^\circ\text{C}$		0.001	10	MHz
$V_{SENSORMAX}$	Maximum oscillation amplitude (peak)			1.8		V
$N_{BITS}$	Number of bits	RESET_DEV.OUTPUT_GAIN=b00 RCOUNTx $\geq$ 0x0400			12	bits
$f_{CS}$	Maximum Channel Sample Rate	single active channel continuous conversion, SCL=400 kHz			13.3	kSPS
$C_{IN}$	Sensor Pin input capacitance			4		pF
<b>DIGITAL PIN LEVELS</b>						
$V_{IL}$	Low voltage threshold (ADDR and SD)				$0.3 \cdot V_{DD}$	V
$V_{IH}$	High voltage threshold (ADDR and SD)			$0.7 \cdot V_{DD}$		V
$V_{OL}$	INTB low voltage output level	3mA sink current			0.4	V
$V_{OH}$	INTB high voltage output level			2.4		V
<b>REFERENCE CLOCK</b>						
$f_{CLKIN}$	External Reference Clock Input Frequency (CLKIN)	$T_A = -40^\circ\text{C}$ to $+125^\circ\text{C}$		2	40	MHz
$CLKIN_{DUTY\_MIN}$	External Reference Clock minimum acceptable duty cycle (CLKIN)			40%		
$CLKIN_{DUTY\_MAX}$	External Reference Clock maximum acceptable duty cycle (CLKIN)			60%		
$V_{CLKIN\_LO}$	CLKIN low voltage threshold				$0.3 \cdot V_{DD}$	V
$V_{CLKIN\_HI}$	CLKIN high voltage threshold			$0.7 \cdot V_{DD}$		V

- Electrical Characteristics Table values apply only for factory testing conditions at the temperature indicated. Factory testing conditions result in very limited self-heating of the device such that  $T_J = T_A$ . No guarantee of parametric performance is indicated in the electrical tables under conditions of internal self-heating where  $T_J > T_A$ . Absolute Maximum Ratings indicate junction temperature limits beyond which the device may be permanently degraded, either mechanically or electrically.
- Register values are represented as either binary (b is the prefix to the digits), or hexadecimal (0x is the prefix to the digits). Decimal values have no prefix.
- Limits are ensured by testing, design, or statistical analysis at  $25^\circ\text{C}$ . Limits over the operating temperature range are ensured through correlations using statistical quality control (SQC) method.
- Typical values represent the most likely parametric norm as determined at the time of characterization. Actual typical values may vary over time and will also depend on the application and configuration. The typical values are not tested and are not guaranteed on shipped production material.
- I<sup>2</sup>C read/write communication and pull-up resistors current through SCL, SDA not included.
- Sensor inductor: 2 layer, 32 turns/layer, 14 mm diameter, PCB inductor with  $L=19.4\ \mu\text{H}$ ,  $R_P=5.7\ \text{k}\Omega$  at 2 MHz Sensor capacitor: 330 pF 1% COG/NP0 Target: Aluminum, 1.5 mm thickness Channel = Channel 0 (continuous mode)  $f_{CLKIN} = 40\ \text{MHz}$ , FIN\_DIVIDER0 = b0000, FREF\_DIVIDER0 = 0x0001, RCOUNT0 = 0xFFFF, SETTLECOUNT0 = 0x0100, RP\_OVERRIDE = b1, AUTO\_AMP\_DIS = b1, DRIVE\_CURRENT0 = 0x9800

### Electrical Characteristics (continued)

Unless otherwise specified, all limits ensured for  $T_A = 25^\circ\text{C}$ ,  $V_{DD} = 3.3\text{ V}$ . See <sup>(1)</sup>

PARAMETER	TEST CONDITIONS <sup>(2)</sup>	MIN <sup>(3)</sup>	TYP <sup>(4)</sup>	MAX <sup>(3)</sup>	UNIT
$f_{\text{INTCLK}}$	Internal Reference Clock Frequency range	35	43.4	55	MHz
$T_{\text{Cf\_int\_}\mu}$	Internal Reference Clock Temperature Coefficient mean		-13		ppm/ $^\circ\text{C}$
<b>TIMING CHARACTERISTICS</b>					
$t_{\text{WAKEUP}}$	Wake-up Time from SD high-low transition to I2C readback			2	ms
$t_{\text{WD-TIMEOUT}}$	Sensor recovery time (after watchdog timeout)		5.2		ms

### 6.6 Switching Characteristics - I2C

Unless otherwise specified, all limits ensured for  $T_A = 25^\circ\text{C}$ ,  $V_{DD} = 3.3\text{ V}$

PARAMETER	TEST CONDITIONS	MIN	TYP	MAX	UNIT
<b>VOLTAGE LEVELS</b>					
$V_{\text{IH}}$	Input High Voltage	$0.7 \times V_{\text{DD}}$			V
$V_{\text{IL}}$	Input Low Voltage			$0.3 \times V_{\text{DD}}$	V
$V_{\text{OL}}$	Output Low Voltage (3mA sink current)			0.4	V
HYS	Hysteresis		$0.1 \times V_{\text{DD}}$		V
<b>I2C TIMING CHARACTERISTICS</b>					
$f_{\text{SCL}}$	Clock Frequency	10		400	kHz
$t_{\text{LOW}}$	Clock Low Time	1.3			$\mu\text{s}$
$t_{\text{HIGH}}$	Clock High Time	0.6			$\mu\text{s}$
$t_{\text{HD;STA}}$	Hold Time (repeated) START condition	After this period, the first clock pulse is generated	0.6		$\mu\text{s}$
$t_{\text{SU;STA}}$	Set-up time for a repeated START condition		0.6		$\mu\text{s}$
$t_{\text{HD;DAT}}$	Data hold time	0			$\mu\text{s}$
$t_{\text{SU;DAT}}$	Data setup time	100			ns
$t_{\text{SU;STO}}$	Set-up time for STOP condition	0.6			$\mu\text{s}$
$t_{\text{BUF}}$	Bus free time between a STOP and START condition	1.3			$\mu\text{s}$
$t_{\text{VD;DAT}}$	Data valid time			0.9	$\mu\text{s}$
$t_{\text{VD;ACK}}$	Data valid acknowledge time			0.9	$\mu\text{s}$
$t_{\text{SP}}$	Pulse width of spikes that must be suppressed by the input filter <sup>(1)</sup>			50	ns

(1) This parameter is specified by design and/or characterization and is not tested in production.

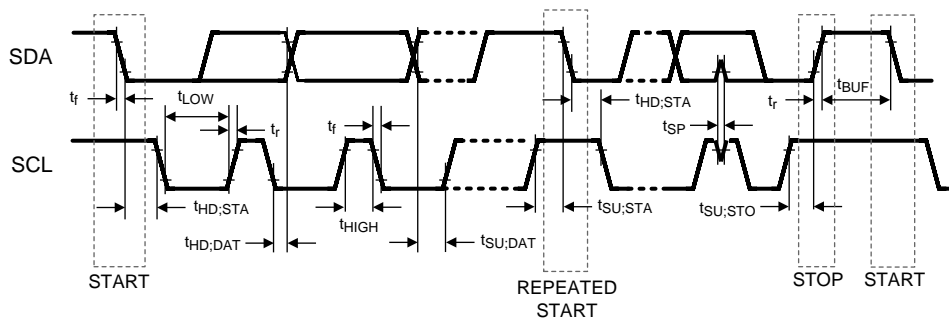
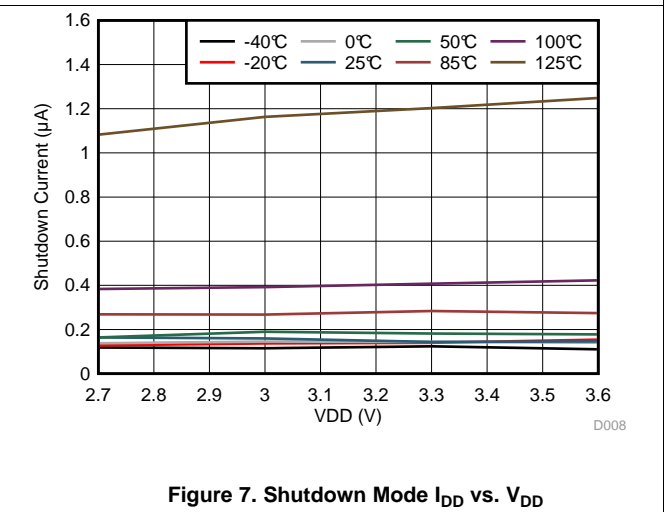
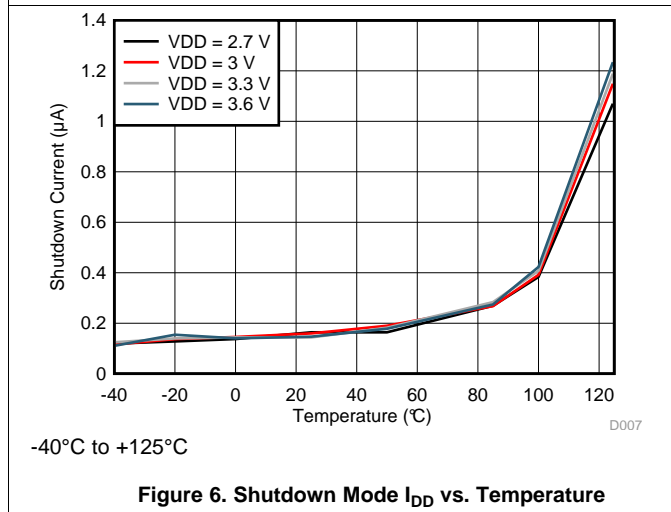
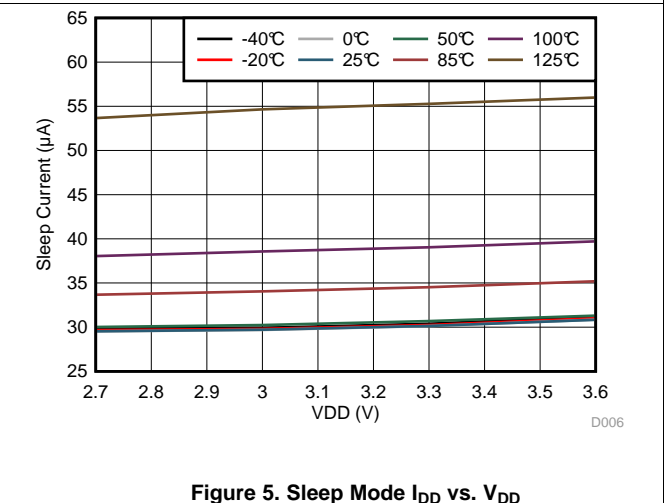
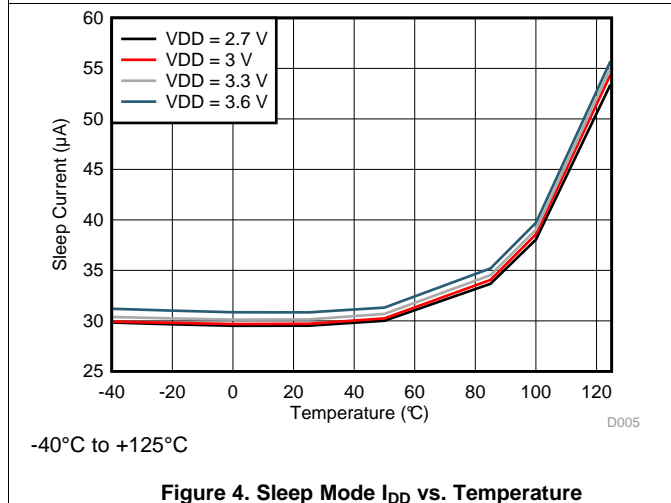
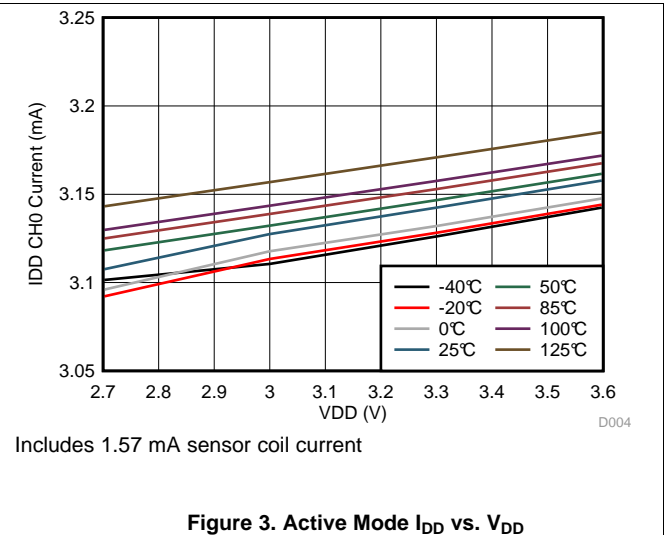
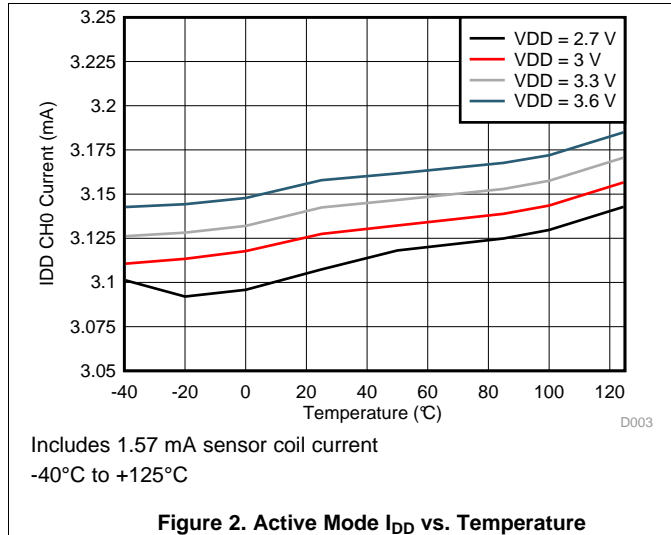

Figure 1. I2C Timing

### 6.7 Typical Characteristics

Common test conditions (unless specified otherwise): Sensor inductor: 2 layer, 32 turns/layer, 14 mm diameter, PCB inductor with L=19.4  $\mu$ H, R<sub>p</sub>=5.7 k $\Omega$  at 2 MHz; Sensor capacitor: 330 pF 1% COG/NP0; Target: Aluminum, 1.5 mm thickness; Channel = Channel 0 (continuous mode);  $f_{CLKIN}$  = 40 MHz, FIN\_DIVIDER0 = 0x1, FREF\_DIVIDER0 = 0x001, RCOUNT0 = 0xFFFF, SETTLECOUNT0 = 0x0100, RP\_OVERRIDE = 1, AUTO\_AMP\_DIS = 1, DRIVE\_CURRENT0 = 0x9800



## Typical Characteristics (continued)

Common test conditions (unless specified otherwise): Sensor inductor: 2 layer, 32 turns/layer, 14 mm diameter, PCB inductor with  $L=19.4 \mu\text{H}$ ,  $R_p=5.7 \text{ k}\Omega$  at 2 MHz; Sensor capacitor: 330 pF 1% COG/NP0; Target: Aluminum, 1.5 mm thickness; Channel = Channel 0 (continuous mode);  $f_{\text{CLKIN}} = 40 \text{ MHz}$ ,  $\text{FIN\_DIVIDER0} = 0x1$ ,  $\text{FREF\_DIVIDER0} = 0x001$ ,  $\text{RCOUNT0} = 0xFFFF$ ,  $\text{SETTLECOUNT0} = 0x0100$ ,  $\text{RP\_OVERRIDE} = 1$ ,  $\text{AUTO\_AMP\_DIS} = 1$ ,  $\text{DRIVE\_CURRENT0} = 0x9800$

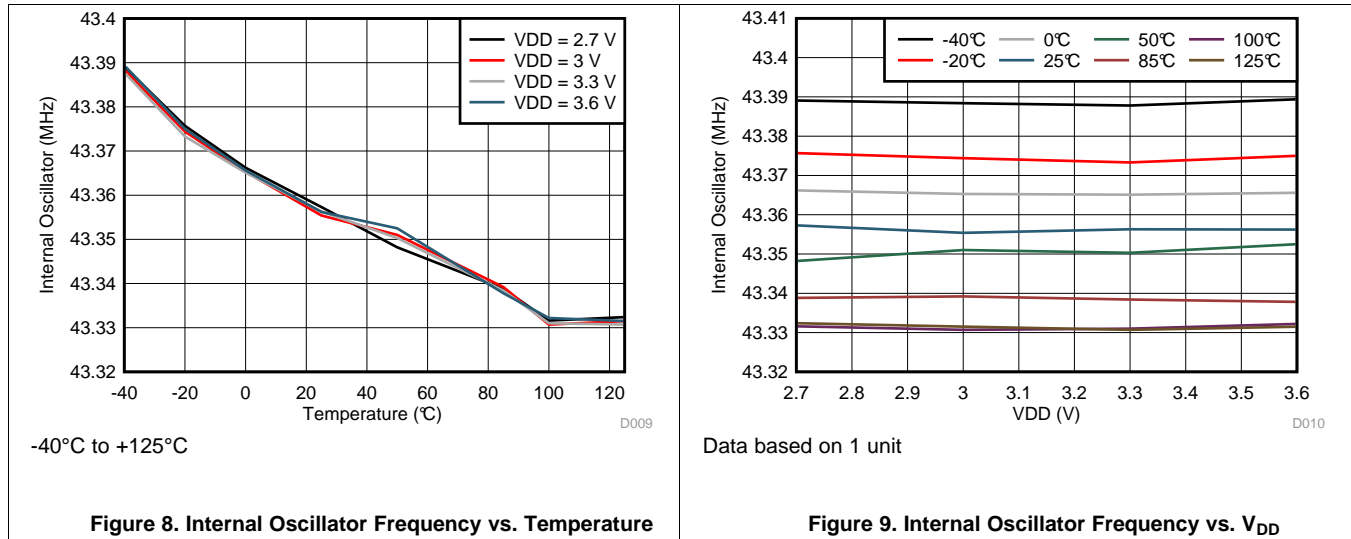

## 7 Detailed Description

### 7.1 Overview

The LDC1312/LDC1314 is an inductance-to-digital converter (LDC) that measures the oscillation frequency of multiple LC resonators. The device outputs a digital value that is proportional to frequency, with 12 bits of measurement resolution. This frequency measurement can be converted to an equivalent inductance, or mapped to the movement of a conductive object. The LDC1312/LDC1314 supports a wide range of inductance and capacitor combinations with oscillation frequencies varying from 1 kHz to 10 MHz with equivalent parallel resistances as low as 1.0 kΩ. The device includes a stable internal reference to reduce overall system cost, while also providing the option to drive a clean external oscillator for improved measurement noise. The conversion time of the LDC1312/LDC1314 is configurable per channel, where longer conversion times provide higher effective resolution.

The LDC1312/LDC1314 is configured through a 400-kbit/s I2C bus and includes the ADDR input pin to select an address. The power supply of the device ranges from 2.7 V to 3.6 V. The only external components necessary for operation are the supply bypassing capacitors and I2C pull-ups.

### 7.2 Functional Block Diagram

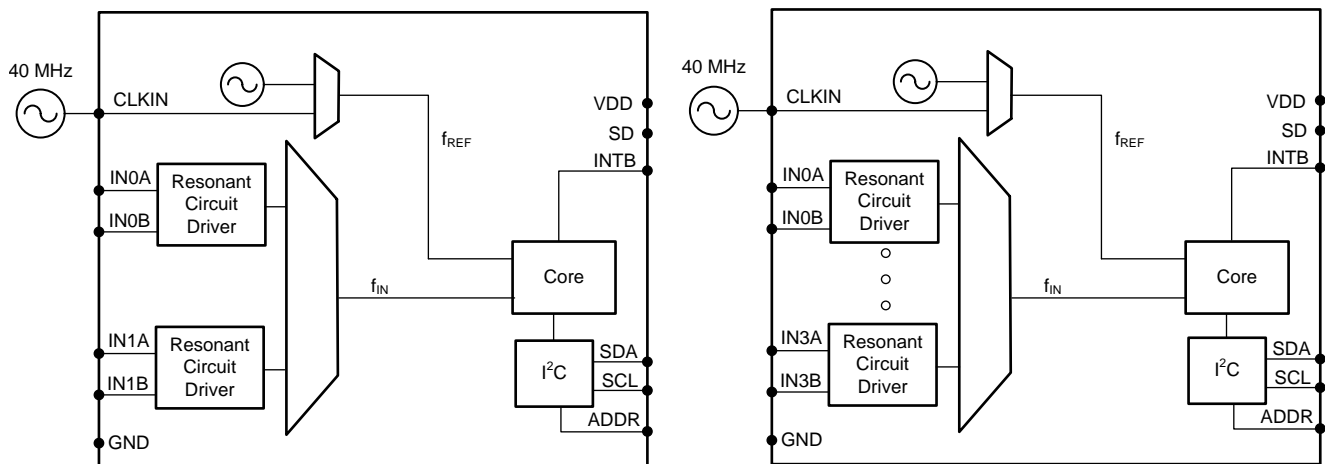

Copyright © 2016, Texas Instruments Incorporated

Figure 10. Block Diagrams for the LDC1312 (Left) and LDC1314 (Right)

The LDC1312/LDC1314 is composed of front-end resonant circuit drivers, followed by a multiplexer that sequences through the active channels, connecting them to the core that measures and digitizes the sensor frequency ( $f_{SENSOR}$ ). The core uses a reference frequency ( $f_{REF}$ ) to measure the sensor frequency.  $f_{REF}$  is derived from either the internal reference clock (oscillator), or an externally supplied clock. The digitized output for each channel is proportional to the ratio of  $f_{SENSOR}/f_{REF}$ . The I2C interface is used to support device configuration and to transmit the digitized frequency values to a host processor. The LDC can be placed in an inactive shutdown mode to reduce current consumption by setting the SD pin to  $V_{DD}$ . The INTB pin may be configured to notify the host of changes in system status.

### 7.3 Feature Description

#### 7.3.1 Multi-Channel and Single Channel Operation

The LDC1312/LDC1314 provides flexibility in channel sampling. It can continuously convert on any available single channel or automatically sequence conversions across multiple channels. When operated in multi-channel mode, the LDC sequentially samples the selected channels. In single channel mode, the LDC continuously samples only the selected channel.

## Feature Description (continued)

At the end of each conversion in single channel mode, or after converting all selected channels when in multi-channel mode, the LDC1312/LDC1314 can be configured to assert the INTB pin to indicate completion of the conversion.

Refer to [Multi-Channel and Single Channel Operation](#) for details on the LDC1312/LDC1314 channel functionality and configuration.

### 7.3.2 Adjustable Conversion Time

The LDC1312/LDC1314 conversion provides a tradeoff between measurement resolution and conversion interval. Longer conversion intervals have higher measurement resolution. The conversion interval can be configured from 3.2  $\mu$ s to >26.2 ms with 16 bits of resolution. Note that it is possible to configure the conversion interval to be shorter than the time required to read back the DATAx registers. The LDC1312/LDC1314 supports per-channel adjustment of the conversion interval by setting the RCOUNTx register.

Refer to [Sensor Conversion Time](#) for details on the LDC1312/LDC1314 configuration and details on the setting conversion interval.

### 7.3.3 Digital Signal Gain

The LDC1312/LDC1314 output resolution is 12 bits, but the internal signal path supports 16 bits of output resolution by use of the GAIN setting.

Refer to [Digital Signal Gain](#) for details on the configuration and details on the setting conversion interval.

### 7.3.4 Sensor Startup and Glitch Configuration

For minimum noise, the sensor measurement should be performed after the sensor amplitude has stabilized. The LDC1312/LDC1314 provides an adjustable sensor startup timing per channel. The timing can be varied from 1.2  $\mu$ s to >26.2 ms by setting the SETTLECOUNTx register. Sensors with lower resonant frequencies or higher Qs may require additional time to stabilize.

Refer to [Settling Time](#) for details on the LDC1312/LDC1314 configuration and details on the setting conversion interval.

The LDC1312/LDC1314 can be configured with a faster sensor activation, or to use a lower current sensor activation. Refer to [Sensor Activation](#) for details on this capability.

The LDC1312/LDC1314 provides an internal filter to attenuate interference from external noise sources. Refer to [Input Deglitch Filter](#) for information on configuration on the deglitch filter.

### 7.3.5 Reference Clock

Optimum LDC1312/LDC1314 performance requires a clean reference clock. This reference frequency is equivalent to the reference voltage of an Analog-to-Digital converter. The LDC1312/LDC1314 provide an internal reference oscillator with a typical frequency of 43 MHz. This internal oscillator has good stability, with a typical temperature coefficient of -13 ppm/°C. For applications requiring higher resolution or improved performance across temperature, an external reference frequency can be applied to the CLKIN input.

The LDC1312/LDC1314 provides digital dividers for the  $f_{CLK}$  and the sensor inputs to adjust the effective frequency measured by the LDC core. The dividers provide flexibility in system design, so that the full range of sensor frequencies can be supported with a wide range of  $f_{CLK}$ . Each channel has a dedicated divider configuration. Higher reference frequencies provide a higher sample rate for a given resolution.

Refer to [Reference Clock](#) for details on clocking requirements, configuration, and divider setup.

## Feature Description (continued)

### 7.3.6 Sensor Current Drive Control

The lossy characteristic of the sensors used for inductive sensing require injection of energy to maintain a constant sensor amplitude. The LDC1312/LDC1314 provides this energy by driving an AC current matching the sensor resonant frequency across the LC sensor. To achieve optimum performance, it is necessary to set the current drive so that the sensor amplitude is within the range of  $1.2 V_p$  to  $1.8 V_p$ . Each channel current drive is set independently between  $16 \mu\text{A}$  and  $1.6 \text{ mA}$  by setting the corresponding IDRIVEx register field. The LDC1312/LDC1314 can also automatically determine the appropriate sensor current drive, and even dynamically adjust the sensor current by use of the RP\_OVERRIDE\_EN function.

Refer to [Sensor Current Drive Configuration](#) for detailed information on configuration of the sensor drive.

### 7.3.7 Device Status Monitoring

The LDC1312/LDC1314 can monitor attached sensors and can report on device status and sensor status via the I2C interface. Reported conditions include:

- Sensor Amplitude outside of optimum range
- Sensor unable to oscillate
- New conversion data available
- Conversion errors

Use of this monitoring functionality can alert the system MCU of unexpected conditions such as sensor damage. Refer to [Device Status Registers](#) for more information.

## 7.4 Device Functional Modes

### 7.4.1 Startup Mode

When the LDC powers up, it enters into Sleep Mode and will wait for configuration. Once the device is configured, exit Sleep Mode and begin conversions by setting CONFIG.SLEEP\_MODE\_EN to b0.

It is recommended to configure the LDC while in Sleep Mode. If a setting on the LDC needs to be changed, return the device to Sleep Mode, change the appropriate register, and then exit Sleep Mode.

### 7.4.2 Sleep Mode (Configuration Mode)

Sleep Mode is entered by setting the CONFIG.SLEEP\_MODE\_EN register field to 1. While in this mode, the device configuration is retained, but the device does not perform conversions. To enter Normal mode to perform conversions, set the CONFIG.SLEEP\_MODE\_EN register field to 0. After setting CONFIG.SLEEP\_MODE\_EN to b0, sensor activation for the first conversion will begin after  $16,384 \div f_{INT}$  elapses. Refer to [Clocking Architecture](#) for more information on the device timing.

While in Sleep Mode the I2C interface is functional so that register reads and writes can be performed. Entering Sleep Mode will clear all conversion results, any error conditions, and de-assert the INTB pin.

For applications which do not require continuous conversions, returning the device to Sleep mode after completion and readback of the desired number of conversions can provide power consumption savings. Refer to the TI Applications Note [Power Reduction Techniques for the LDC131x/161x for Inductive Sensing](#) for more information.

### 7.4.3 Normal (Conversion) Mode

When operating in the normal (conversion) mode, the LDC is repeatedly sampling the frequency of the sensor(s) and generating sample outputs for the active channel(s) based on the device configuration.

### 7.4.4 Shutdown Mode

When the SD pin is set to high, the LDC will enter Shutdown Mode. Shutdown Mode is the lowest power state. To exit Shutdown Mode and enter Sleep Mode, set the SD pin to low. Entering Shutdown Mode will return all registers to their default state.

## Device Functional Modes (continued)

While in Shutdown Mode, no conversions are performed. In addition, entering Shutdown Mode will clear any error condition and de-assert the INTB pin (when de-asserted, INTB will be actively driven high). While the device is in Shutdown Mode, it is not possible to read to or write from the device via the I2C interface.

It is permitted to change the ADDR pin setting while in Shutdown Mode.

### 7.4.4.1 Reset

The device can be reset by writing to RESET\_DEV.RESET\_DEV. Any active conversion will stop and all registers will return to their default values. This register bit will always return 0b when read.

## 7.5 Programming

The LDC1312/4 device uses an I2C interface to access control and data registers. The recommended configuration procedure is to put the device into Sleep Mode, set the appropriate registers, and then enter Normal Mode. Conversion results must be read while the device is in Normal Mode. Setting the device into Shutdown mode will reset the device configuration.

### 7.5.1 I2C Interface Specifications

The LDC1312/4 use I2C for register access with a maximum speed of 400 kbit/s. The device registers are 16 bits wide, and so a repeated start is used to access the 2<sup>nd</sup> byte of data. This sequence follows the standard I2C 7bit slave address followed by an 8 bit pointer register byte to set the register address. Refer to [Figure 11](#) and [Figure 12](#) for proper protocol diagrams. The device does not use I2C clock stretching.

When the ADDR pin is set low, the device I2C address is 0x2A; when the ADDR pin is set high, the I2C address is 0x2B. The ADDR pin setting can be changed while the device is in Shutdown Mode to select the alternate I2C address.

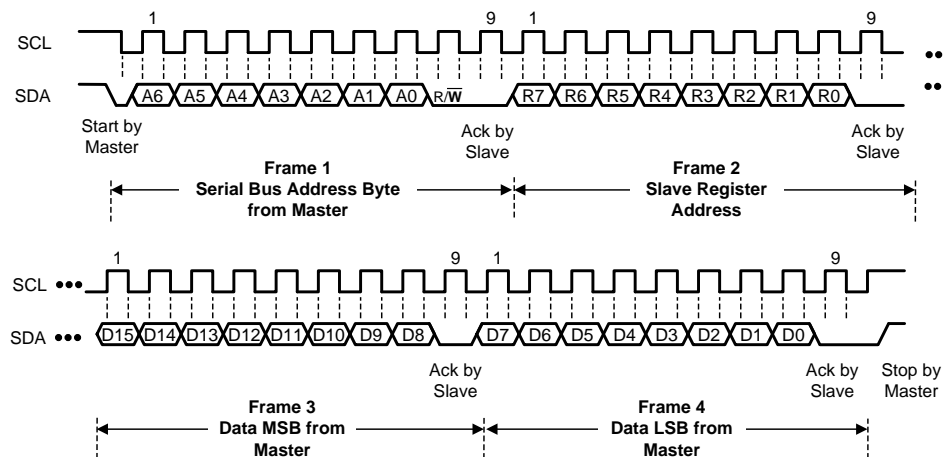

**Figure 11. I2C Write Register Sequence**

Programming (continued)

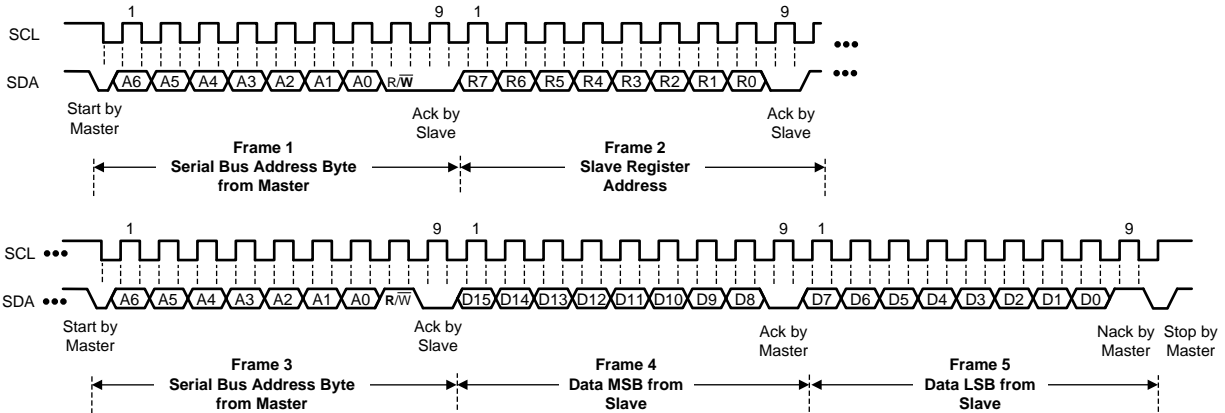

Figure 12. I2C Read Register Sequence

7.5.2 Pulses on I2C

The I2C interface of the LDC is designed to operate with the standard I2C transactions detailed in the I2C specification; however it is not suitable for use in an I2C system which supports early termination of transactions. A STOP condition or other early termination occurring before the normal end of a transaction (ACK) is not supported and may corrupt that transaction and/or the following transaction. The device is also sensitive to any (extraneous) pulse on SDA during the SCL low period of the first bit position of the i2c\_address byte. To ensure proper LDC operation, the master device should not transmit this type of waveform. An example of an unsupported I2C waveform is shown in Figure 13. Any such pulses should not have a duration which exceeds the device  $t_{SP}$  specification.

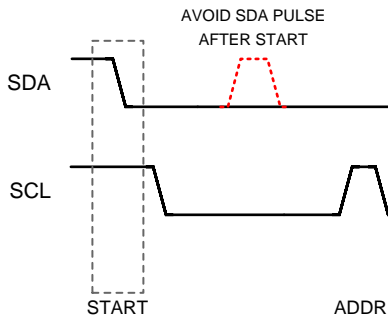

Figure 13. Example of SDA Pulse Between I2C START and ADDR Which Must Be Avoided by the I2C Master

## 7.6 Register Maps

### 7.6.1 Register List

Fields indicated with **Reserved** must be written only with indicated value, otherwise improper device operation may occur. The R/W column indicates the Read-Write status of the corresponding field. A 'R/W' entry indicates read and write capability, a 'R' indicates read-only, and a 'W' indicates write-only.

For registers with R and R/W fields, write the reset value to the field when setting the R/W fields.

**Figure 14. Register List**

ADDRESS	NAME	DEFAULT VALUE	DESCRIPTION
0x00	DATA0	0x0000	Channel 0 Conversion Result and Error Status
0x02	DATA1	0x0000	Channel 1 Conversion Result and Error Status
0x04	DATA2	0x0000	Channel 2 Conversion Result and Error Status <b>(LDC1314 only)</b>
0x06	DATA3	0x0000	Channel 3 Conversion Result and Error Status <b>(LDC1314 only)</b>
0x08	RCOUNT0	0x0080	Reference Count setting for Channel 0
0x09	RCOUNT1	0x0080	Reference Count setting for Channel 1
0x0A	RCOUNT2	0x0080	Reference Count setting for Channel 2. <b>(LDC1314 only)</b>
0x0B	RCOUNT3	0x0080	Reference Count setting for Channel 3. <b>(LDC1314 only)</b>
0x0C	OFFSET0	0x0000	Offset value for Channel 0
0x0D	OFFSET1	0x0000	Offset value for Channel 1
0x0E	OFFSET2	0x0000	Offset value for Channel 2 <b>(LDC1314 only)</b>
0x0F	OFFSET3	0x0000	Offset value for Channel 3 <b>(LDC1314 only)</b>
0x10	SETTLECOUNT0	0x0000	Channel 0 Settling Reference Count
0x11	SETTLECOUNT1	0x0000r_	Channel 1 Settling Reference Count
0x12	SETTLECOUNT2	0x0000	Channel 2 Settling Reference Count <b>(LDC1314 only)</b>
0x13	SETTLECOUNT3	0x0000	Channel 3 Settling Reference Count <b>(LDC1314 only)</b>
0x14	CLOCK_DIVIDERS0	0x0000	Reference and Sensor Divider settings for Channel 0
0x15	CLOCK_DIVIDERS1	0x0000	Reference and Sensor Divider settings for Channel 1
0x16	CLOCK_DIVIDERS2	0x0000	Reference and Sensor Divider settings for Channel 2 <b>(LDC1314 only)</b>
0x17	CLOCK_DIVIDERS3	0x0000	Reference and Sensor Divider settings for Channel 3 <b>(LDC1314 only)</b>
0x18	STATUS	0x0000	Device Status Report
0x19	ERROR_CONFIG	0x0000	Error Reporting Configuration
0x1A	CONFIG	0x2801	Conversion Configuration
0x1B	MUX_CONFIG	0x020F	Channel Multiplexing Configuration
0x1C	RESET_DEV	0x0000	Reset Device
0x1E	DRIVE_CURRENT0	0x0000	Channel 0 sensor current drive configuration
0x1F	DRIVE_CURRENT1	0x0000	Channel 1 sensor current drive configuration
0x20	DRIVE_CURRENT2	0x0000	Channel 2 sensor current drive configuration <b>(LDC1314 only)</b>
0x21	DRIVE_CURRENT3	0x0000	Channel 3 sensor current drive configuration <b>(LDC1314 only)</b>
0x7E	MANUFACTURER_ID	0x5449	Manufacturer ID
0x7F	DEVICE_ID	0x3054	Device ID

### 7.6.2 Address 0x00, DATA0

**Figure 15. Address 0x00, DATA0**

15	14	13	12	11	10	9	8
ERR_UR0	ERR_OR0	ERR_WD0	ERR_AE0	DATA0[11:0]			
7	6	5	4	3	2	1	0
DATA0[11:0]							

LEGEND: R/W = Read/Write; R = Read only; -n = value after reset

**Table 1. Address 0x00, DATA0 Field Descriptions**

Bit	Field	Type	Reset	Description
15	ERR_UR0	R	0	<b>Channel 0 Conversion Under-range Error Flag</b> Cleared by reading the bit.
14	ERR_OR0	R	0	<b>Channel 0 Conversion Over-range Error Flag</b> Cleared by reading the bit.
13	ERR_WD0	R	0	<b>Channel 0 Conversion Watchdog Timeout Error Flag</b> Cleared by reading the bit.
12	ERR_AE0	R	0	<b>Channel 0 Conversion Amplitude Error Flag.</b> Cleared by reading the bit.
11:0	DATA0[11:0]	R	0x000	<b>Channel 0 Conversion Result</b>

### 7.6.3 Address 0x02, DATA1

**Figure 16. Address 0x02, DATA1**

15	14	13	12	11	10	9	8
ERR_UR1	ERR_OR1	ERR_WD1	ERR_AE1	DATA1[11:0]			
7	6	5	4	3	2	1	0
DATA1[11:0]							

LEGEND: R/W = Read/Write; R = Read only; -n = value after reset

**Table 2. Address 0x02, DATA1 Field Descriptions**

Bit	Field	Type	Reset	Description
15	ERR_UR1	R	0	<b>Channel 1 Conversion Under-range Error Flag</b> Cleared by reading the bit.
14	ERR_OR1	R	0	<b>Channel 1 Conversion Over-range Error Flag</b> Cleared by reading the bit.
13	ERR_WD1	R	0	<b>Channel 1 Conversion Watchdog Timeout Error Flag</b> Cleared by reading the bit.
12	ERR_AE1	R	0	<b>Channel 1 Conversion Amplitude Error Flag</b> Cleared by reading the bit.
11:0	DATA1[11:0]	R	0x000	<b>Channel 1 Conversion Result</b>

**7.6.4 Address 0x04, DATA2 (LDC1314 only)**
**Figure 17. Address 0x04, DATA2**

15	14	13	12	11	10	9	8
ERR_UR2	ERR_OR2	ERR_WD2	ERR_AE2	DATA2[11:0]			
7	6	5	4	3	2	1	0
DATA2[11:0]							

LEGEND: R/W = Read/Write; R = Read only; -n = value after reset

**Table 3. Address 0x04, DATA2 Field Descriptions**

Bit	Field	Type	Reset	Description
15	ERR_UR2	R	0	<b>Channel 2 Conversion Under-range Error Flag</b> Cleared by reading the bit.
14	ERR_OR2	R	0	<b>Channel 2 Conversion Over-range Error Flag</b> Cleared by reading the bit.
13	ERR_WD2	R	0	<b>Channel 2 Conversion Watchdog Timeout Error Flag</b> Cleared by reading the bit.
12	ERR_AE2	R	0	<b>Channel 2 Conversion Amplitude Error Flag</b> Cleared by reading the bit.
11:0	DATA2[11:0]	R	0x000	<b>Channel 2 Conversion Result</b>

**7.6.5 Address 0x06, DATA3 (LDC1314 only)**
**Figure 18. Address 0x06, DATA3**

15	14	13	12	11	10	9	8
ERR_UR3	ERR_OR3	ERR_WD3	ERR_AE3	DATA3 [11:0]			
7	6	5	4	3	2	1	0
DATA3 [11:0]							

LEGEND: R/W = Read/Write; R = Read only; -n = value after reset

**Table 4. Address 0x06, DATA3 Field Descriptions**

Bit	Field	Type	Reset	Description
15	ERR_UR3	R	0	<b>Channel 3 Conversion Under-range Error Flag</b> Cleared by reading the bit.
14	ERR_OR3	R	0	<b>Channel 3 Conversion Over-range Error Flag</b> Cleared by reading the bit.
13	ERR_WD3	R	0	<b>Channel 3 Conversion Watchdog Timeout Error Flag</b> Cleared by reading the bit.
12	ERR_AE3	R	0	<b>Channel 3 Conversion Amplitude Error Flag</b> Cleared by reading the bit.
11:0	DATA3[11:0]	R	0x000	<b>Channel 3 Conversion Result</b>

**7.6.6 Address 0x08, RCOUNT0**
**Figure 19. Address 0x08, RCOUNT0**

15	14	13	12	11	10	9	8
RCOUNT0							
7	6	5	4	3	2	1	0
RCOUNT0							

LEGEND: R/W = Read/Write; R = Read only; -n = value after reset

**Table 5. Address 0x08, RCOUNT0 Field Descriptions**

Bit	Field	Type	Reset	Description
15:0	RCOUNT0	R/W	0x0080	<b>Channel 0 Reference Count Conversion Interval Time</b> 0x0000-0x0004: Reserved 0x0005-0xFFFF: Conversion Time ( $t_{C0}$ ) = $(RCOUNT0 \times 16) / f_{REF0}$

**7.6.7 Address 0x09, RCOUNT1**
**Figure 20. Address 0x09, RCOUNT1**

15	14	13	12	11	10	9	8
RCOUNT1							
7	6	5	4	3	2	1	0
RCOUNT1							

LEGEND: R/W = Read/Write; R = Read only; -n = value after reset

**Table 6. Address 0x09, RCOUNT1 Field Descriptions**

Bit	Field	Type	Reset	Description
15:0	RCOUNT1	R/W	0x0080	<b>Channel 1 Reference Count Conversion Interval Time</b> 0x0000-0x0004: Reserved 0x0005-0xFFFF: Conversion Time ( $t_{C1}$ ) = $(RCOUNT1 \times 16) / f_{REF1}$

**7.6.8 Address 0x0A, RCOUNT2 (LDC1314 only)**
**Figure 21. Address 0x0A, RCOUNT2**

15	14	13	12	11	10	9	8
RCOUNT2							
7	6	5	4	3	2	1	0
RCOUNT2							

LEGEND: R/W = Read/Write; R = Read only; -n = value after reset

**Table 7. Address 0x0A, RCOUNT2 Field Descriptions**

Bit	Field	Type	Reset	Description
15:0	RCOUNT2	R/W	0x0080	<b>Channel 2 Reference Count Conversion Interval Time</b> 0x0000-0x0004: Reserved 0x0005-0xFFFF: Conversion Time ( $t_{C2}$ ) = $(RCOUNT2 \times 16) / f_{REF2}$

**7.6.9 Address 0x0B, RCOUNT3 (LDC1314 only)**
**Figure 22. Address 0x0B, RCOUNT3**

15	14	13	12	11	10	9	8
RCOUNT3							
7	6	5	4	3	2	1	0
RCOUNT3							

LEGEND: R/W = Read/Write; R = Read only; -n = value after reset

**Table 8. Address 0x0B, RCOUNT3 Field Descriptions**

Bit	Field	Type	Reset	Description
15:0	RCOUNT3	R/W	0x0080	<b>Channel 3 Reference Count Conversion Interval Time</b> 0x0000-0x0004: Reserved 0x0005-0xFFFF: Conversion Time ( $t_{C3} = (RCOUNT3 \times 16) / f_{REF3}$ )

**7.6.10 Address 0x0C, OFFSET0**
**Figure 23. Address 0x0C, OFFSET0**

15	14	13	12	11	10	9	8
OFFSET0							
7	6	5	4	3	2	1	0
OFFSET0							

LEGEND: R/W = Read/Write; R = Read only; -n = value after reset

**Table 9. OFFSET0 Field Descriptions**

Bit	Field	Type	Reset	Description
15:0	OFFSET0	R/W	0x0000	<b>Channel 0 Conversion Offset</b> $f_{OFFSET0} = (OFFSET0 \div 2^{16}) \times f_{REF0}$

**7.6.11 Address 0x0D, OFFSET1**
**Figure 24. Address 0x0D, OFFSET1**

15	14	13	12	11	10	9	8
OFFSET1							
7	6	5	4	3	2	1	0
OFFSET1							

LEGEND: R/W = Read/Write; R = Read only; -n = value after reset

**Table 10. Address 0x0D, OFFSET1 Field Descriptions**

Bit	Field	Type	Reset	Description
15:0	OFFSET1	R/W	0x0000	<b>Channel 1 Conversion Offset</b> $f_{OFFSET1} = (OFFSET1 \div 2^{16}) \times f_{REF1}$

**7.6.12 Address 0x0E, OFFSET2 (LDC1314 only)**
**Figure 25. Address 0x0E, OFFSET2**

15	14	13	12	11	10	9	8
OFFSET2							
7	6	5	4	3	2	1	0
OFFSET2							

LEGEND: R/W = Read/Write; R = Read only; -n = value after reset

**Table 11. Address 0x0E, OFFSET2 Field Descriptions**

Bit	Field	Type	Reset	Description
15:0	OFFSET2	R/W	0x0000	<b>Channel 2 Conversion Offset</b> $f_{\text{OFFSET}_2} = (\text{OFFSET2} \div 2^{16}) \times f_{\text{REF2}}$

**7.6.13 Address 0x0F, OFFSET3 (LDC1314 only)**
**Figure 26. Address 0x0F, OFFSET3**

15	14	13	12	11	10	9	8
OFFSET3							
7	6	5	4	3	2	1	0
OFFSET3							

LEGEND: R/W = Read/Write; R = Read only; -n = value after reset

**Table 12. Address 0x0F, OFFSET3 Field Descriptions**

Bit	Field	Type	Reset	Description
15:0	OFFSET3	R/W	0x0000	<b>Channel 3 Conversion Offset</b> $f_{\text{OFFSET3}} = (\text{OFFSET3} \div 2^{16}) \times f_{\text{REF3}}$

**7.6.14 Address 0x10, SETTLECOUNT0**
**Figure 27. Address 0x10, SETTLECOUNT0**

15	14	13	12	11	10	9	8
SETTLECOUNT0							
7	6	5	4	3	2	1	0
SETTLECOUNT0							

LEGEND: R/W = Read/Write; R = Read only; -n = value after reset

**Table 13. Address 0x10, SETTLECOUNT0 Field Descriptions**

Bit	Field	Type	Reset	Description
15:0	SETTLECOUNT0	R/W	0x0000	<b>Channel 0 Conversion Settling</b> The LDC will use this settling time to allow the LC sensor to stabilize before initiation of a conversion on Channel 0. If the amplitude has not settled prior to the conversion start, an Amplitude error will be generated if reporting of this type of error is enabled. 0x0000: Settle Time ( $t_{S0}$ ) = $32 \div f_{\text{REF0}}$ 0x0001: Settle Time ( $t_{S0}$ ) = $32 \div f_{\text{REF0}}$ 0x0002 - 0xFFFF: Settle Time ( $t_{S0}$ ) = $(\text{SETTLECOUNT0} \times 16) \div f_{\text{REF0}}$

**7.6.15 Address 0x11, SETTLECOUNT1**
**Figure 28. Address 0x11, SETTLECOUNT1**

15	14	13	12	11	10	9	8
SETTLECOUNT1							
7	6	5	4	3	2	1	0
SETTLECOUNT1							

LEGEND: R/W = Read/Write; R = Read only; -n = value after reset

**Table 14. Address 0x11, SETTLECOUNT1 Field Descriptions**

Bit	Field	Type	Reset	Description
15:0	SETTLECOUNT1	R/W	0x0000	<b>Channel 1 Conversion Settling</b> The LDC will use this settling time to allow the LC sensor to stabilize before initiation of a conversion on a Channel 1. If the amplitude has not settled prior to the conversion start, an Amplitude error will be generated if reporting of this type of error is enabled. 0x0000: Settle Time ( $t_{S1}$ ) = $32 \div f_{REF1}$ 0x0001: Settle Time ( $t_{S1}$ ) = $32 \div f_{REF1}$ 0x0002 - 0xFFFF: Settle Time ( $t_{S1}$ ) = (SETTLECOUNT1 × 16) ÷ $f_{REF1}$

**7.6.16 Address 0x12, SETTLECOUNT2 (LDC1314 only)**
**Figure 29. Address 0x12, SETTLECOUNT2**

15	14	13	12	11	10	9	8
SETTLECOUNT2							
7	6	5	4	3	2	1	0
SETTLECOUNT2							

LEGEND: R/W = Read/Write; R = Read only; -n = value after reset

**Table 15. Address 0x12, SETTLECOUNT2 Field Descriptions**

Bit	Field	Type	Reset	Description
15:0	SETTLECOUNT2	R/W	0x0000	<b>Channel 2 Conversion Settling</b> The LDC will use this settling time to allow the LC sensor to stabilize before initiation of a conversion on Channel 2. If the amplitude has not settled prior to the conversion start, an Amplitude error will be generated if reporting of this type of error is enabled. 0x0000: Settle Time ( $t_{S2}$ ) = $32 \div f_{REF2}$ 0x0001: Settle Time ( $t_{S2}$ ) = $32 \div f_{REF2}$ 0x0002 - 0xFFFF: Settle Time ( $t_{S2}$ ) = (SETTLECOUNT2 × 16) ÷ $f_{REF2}$

**7.6.17 Address 0x13, SETTLECOUNT3 (LDC1314 only)**
**Figure 30. Address 0x13, SETTLECOUNT3**

15	14	13	12	11	10	9	8
SETTLECOUNT3							
7	6	5	4	3	2	1	0
SETTLECOUNT3							

LEGEND: R/W = Read/Write; R = Read only; -n = value after reset

**Table 16. Address 0x13, SETTLECOUNT3 Field Descriptions**

Bit	Field	Type	Reset	Description
15:0	SETTLECOUNT3	R/W	0x0000	<b>Channel 3 Conversion Settling</b> The LDC will use this settling time to allow the LC sensor to stabilize before initiation of a conversion on Channel 3. If the amplitude has not settled prior to the conversion start, an Amplitude error will be generated if reporting of this type of error is enabled 0x0000: Settle Time ( $t_{S3}$ ) = $32 \div f_{REF3}$ 0x0001: Settle Time ( $t_{S3}$ ) = $32 \div f_{REF3}$ 0x0002 - 0xFFFF: Settle Time ( $t_{S3}$ ) = (SETTLECOUNT3 × 16) ÷ $f_{REF3}$

**7.6.18 Address 0x14, CLOCK\_DIVIDERS0**
**Figure 31. Address 0x14, CLOCK\_DIVIDERS0**

15	14	13	12	11	10	9	8
FIN_DIVIDER0				RESERVED		FREF_DIVIDER0	
7	6	5	4	3	2	1	0
FREF_DIVIDER0							

LEGEND: R/W = Read/Write; R = Read only; -n = value after reset

**Table 17. Address 0x14, CLOCK\_DIVIDERS0 Field Descriptions**

Bit	Field	Type	Reset	Description
15:12	FIN_DIVIDER0	R/W	0000	<b>Channel 0 Input Divider</b> Sets the divider for Channel 0 input. Must be set to $\geq 2$ if the Sensor frequency is $\geq 8.75\text{MHz}$ b0000: Reserved. Do not use. $\text{FIN\_DIVIDER0} \geq \text{b0001}$ : $f_{in0} = f_{\text{SENSOR0}} / \text{FIN\_DIVIDER0}$
11:10	RESERVED	R/W	00	Reserved. Set to b00.
9:0	FREF_DIVIDER0	R/W	0x000	<b>Channel 0 Reference Divider</b> Sets the divider for Channel 0 reference. Use this to scale the maximum conversion frequency. 0x000: Reserved. Do not use. $\text{FREF\_DIVIDER0} \geq \text{0x001}$ : $f_{REF0} = f_{\text{CLK}} / \text{FREF\_DIVIDER0}$

**7.6.19 Address 0x15, CLOCK\_DIVIDERS1**
**Figure 32. Address 0x15, CLOCK\_DIVIDERS1**

15	14	13	12	11	10	9	8
FIN_DIVIDER1				RESERVED		FREF_DIVIDER1	
7	6	5	4	3	2	1	0
FREF_DIVIDER1							

LEGEND: R/W = Read/Write; R = Read only; -n = value after reset

**Table 18. Address 0x15, CLOCK\_DIVIDERS1 Field Descriptions**

Bit	Field	Type	Reset	Description
15:12	FIN_DIVIDER1	R/W	0000	<b>Channel 1 Input Divider</b> Sets the divider for Channel 1 input. Used when the Sensor frequency is greater than the maximum $F_{IN}$ . b0000: Reserved. Do not use. $FIN\_DIVIDER1 \geq b0001$ : $f_{in1} = f_{SENSOR1} \div FIN\_DIVIDER1$
11:10	RESERVED	R/W	00	Reserved. Set to b00.
9:0	FREF_DIVIDER1	R/W	0x000	<b>Channel 1 Reference Divider</b> Sets the divider for Channel 1 reference. Use this to scale the maximum conversion frequency. 0x000: Reserved. Do not use. $FREF\_DIVIDER1 \geq 0x001$ : $f_{REF1} = f_{CLK} \div FREF\_DIVIDER1$

**7.6.20 Address 0x16, CLOCK\_DIVIDERS2 (LDC1314 only)**
**Figure 33. Address 0x16, CLOCK\_DIVIDERS2**

15	14	13	12	11	10	9	8
FIN_DIVIDER2				RESERVED		FREF_DIVIDER2	
7	6	5	4	3	2	1	0
FREF_DIVIDER2							

LEGEND: R/W = Read/Write; R = Read only; -n = value after reset

**Table 19. Address 0x16, CLOCK\_DIVIDERS2 Field Descriptions**

Bit	Field	Type	Reset	Description
15:12	FIN_DIVIDER2	R/W	0000	<b>Channel 2 Input Divider</b> Sets the divider for Channel 2 input. Must be set to $\geq 2$ if the Sensor frequency is $\geq 8.75$ MHz. b0000: Reserved. Do not use. $FIN\_DIVIDER2 \geq b0001$ : $f_{IN2} = f_{SENSOR2} \div FIN\_DIVIDER2$
11:10	RESERVED	R/W	00	Reserved. Set to b00.
9:0	FREF_DIVIDER2	R/W	0x000	<b>Channel 2 Reference Divider</b> Sets the divider for Channel 2 reference. Use this to scale the maximum conversion frequency. 0x000: Reserved. Do not use. $FREF\_DIVIDER2 \geq 0x001$ : $f_{REF2} = f_{CLK} \div FREF\_DIVIDER2$

**7.6.21 Address 0x17, CLOCK\_DIVIDERS3 (LDC1314 only)**
**Figure 34. Address 0x17, CLOCK\_DIVIDERS3**

15	14	13	12	11	10	9	8
FIN_DIVIDER3				RESERVED		FREF_DIVIDER3	
7	6	5	4	3	2	1	0
FREF_DIVIDER3							

LEGEND: R/W = Read/Write; R = Read only; -n = value after reset

**Table 20. Address 0x17, CLOCK\_DIVIDERS3**

Bit	Field	Type	Reset	Description
15:12	FIN_DIVIDER3	R/W	0000	<b>Channel 3 Input Divider</b> Sets the divider for Channel 3 input. Must be set to $\geq 2$ if the Sensor frequency is $\geq 8.75$ MHz. b0000: Reserved. Do not use. FIN_DIVIDER3 $\geq$ b0001: $f_{IN3} = f_{SENSOR3} \div FIN\_DIVIDER3$
11:10	RESERVED	R/W	00	Reserved. Set to b00.
9:0	FREF_DIVIDER3	R/W	0x000	<b>Channel 3 Reference Divider</b> Sets the divider for Channel 3 reference. Use this to scale the maximum conversion frequency. 0x000: reserved FREF_DIVIDER3 $\geq$ 0x001: $f_{REF3} = f_{CLK} \div FREF\_DIVIDER3$

**7.6.22 Address 0x18, STATUS**
**Figure 35. Address 0x18, STATUS**

15	14	13	12	11	10	9	8
ERR_CHAN		ERR_UR	ERR_OR	ERR_WD	ERR_AHE	ERR_ALE	ERR_ZC
7	6	5	4	3	2	1	0
RESERVED	DRDY	RESERVED		UNREADCONV0	UNREADCONV1	UNREADCONV2	UNREADCONV3

LEGEND: R/W = Read/Write; R = Read only; -n = value after reset

**Table 21. Address 0x18, STATUS Field Descriptions**

Bit	Field	Type	Reset	Description
15:14	ERR_CHAN	R	00	<b>Error Channel</b> Indicates which channel has generated a Flag or Error. Once flagged, any reported error is latched and maintained until either the STATUS register or the DATAx register corresponding to the Error Channel is read. b00: Channel 0 is source of flag or error. b01: Channel 1 is source of flag or error. b10: Channel 2 is source of flag or error (LDC1314 only). b11: Channel 3 is source of flag or error (LDC1314 only).
13	ERR_UR	R	0	<b>Conversion Under-range Error</b> b0: No Conversion Under-range error was recorded since the last read of the STATUS register. b1: An active channel has generated a Conversion Under-range error. Refer to STATUS.ERR_CHAN field to determine which channel is the source of this error.
12	ERR_OR	R	0	<b>Conversion Over-range Error</b> b0: No Conversion Over-range error was recorded since the last read of the STATUS register. b1: An active channel has generated a Conversion Over-range error. Refer to STATUS.ERR_CHAN field to determine which channel is the source of this error.

**Table 21. Address 0x18, STATUS Field Descriptions (continued)**

Bit	Field	Type	Reset	Description
11	ERR_WD	R	0	<b>Watchdog Timeout Error</b> b0: No Watchdog Timeout error was recorded since the last read of the STATUS register. b1: An active channel has generated a Watchdog Timeout error. Refer to STATUS.ERR_CHAN field to determine which channel is the source of this error.
10	ERR_AHE	R	0	<b>Sensor Amplitude High Error</b> b0: No Amplitude High error was recorded since the last read of the STATUS register. b1: An active channel has generated an Amplitude High error - this occurs when the sensor amplitude is above a nominal 1.8 V. It is recommended to reduce the corresponding sensor IDRIVEx setting. Refer to STATUS.ERR_CHAN field to determine which channel is the source of this error.
9	ERR_ALE	R	0	<b>Sensor Amplitude Low Error</b> b0: No Amplitude Low error was recorded since the last read of the STATUS register. b1: An active channel has generated an Amplitude Low error - this occurs when the sensor amplitude is below a nominal 1.2 V. Refer to STATUS.ERR_CHAN field to determine which channel is the source of this error.
8	ERR_ZC	R	0	<b>Zero Count Error</b> b0: No Zero Count error was recorded since the last read of the STATUS register. b1: An active channel has generated a Zero Count error. Refer to STATUS.ERR_CHAN field to determine which channel is the source of this error.
7	Reserved	R	0	Reserved. Reads 0.
6	DRDY	R	0	<b>Data Ready Flag</b> b0: No new conversion result was recorded in the STATUS register. b1: A new conversion result is ready. When in Single Channel Conversion, this indicates a single conversion is available. When in sequential mode, this indicates that a new conversion result for all active channels is now available.
5:4	Reserved	R	00	Reserved. Reads 00b.
3	UNREADCONV0	R	0	<b>Channel 0 Unread Conversion</b> b0: No unread conversion is present for Channel 0. b1: An unread conversion is present for Channel 0. Read Register DATA0 to retrieve conversion results.
2	UNREADCONV1	R	0	<b>Channel 1 Unread Conversion</b> b0: No unread conversion is present for Channel 1. b1: An unread conversion is present for Channel 1. Read Register DATA1 to retrieve conversion results.
1	UNREADCONV2	R	0	<b>Channel 2 Unread Conversion</b> b0: No unread conversion is present for Channel 2. b1: An unread conversion is present for Channel 2. Read Register DATA2 to retrieve conversion results (LDC1314 only)
0	UNREADCONV3	R	0	<b>Channel 3 Unread Conversion</b> b0: No unread conversion is present for Channel 3. b1: An unread conversion is present for Channel 3. Read Register DATA3 to retrieve conversion results (LDC1314 only)

**7.6.23 Address 0x19, ERROR\_CONFIG**
**Figure 36. Address 0x19, ERROR\_CONFIG**

15		14		13		12		11		10		9		8	
UR_ERR2OUT		OR_ERR2OUT		WD_ERR2OUT		AH_ERR2OUT		AL_ERR2OUT		RESERVED					
7		6		5		4		3		2		1		0	
UR_ERR2INT		OR_ERR2INT		WD_ERR2INT		AH_ERR2INT		AL_ERR2INT		ZC_ERR2INT		Reserved		DRDY_2INT	

LEGEND: R/W = Read/Write; R = Read only; -n = value after reset

**Table 22. Address 0x19, ERROR\_CONFIG**

Bit	Field	Type	Reset	Description
15	UR_ERR2OUT	R/W	0	<b>Under-range Error to Output Register</b> b0: Do not report Under-range errors in the DATAx registers. b1: Report Under-range errors in the DATAx.ERR_URx register field corresponding to the channel that generated the error.
14	OR_ERR2OUT	R/W	0	<b>Over-range Error to Output Register</b> b0: Do not report Over-range errors in the DATAx registers. b1: Report Over-range errors in the DATAx.ERR_ORx register field corresponding to the channel that generated the error.
13	WD_ERR2OUT	R/W	0	<b>Watchdog Timeout Error to Output Register</b> b0: Do not report Watchdog Timeout errors in the DATAx registers. b1: Report Watchdog Timeout errors in the DATAx.ERR_WDx register field corresponding to the channel that generated the error.
12	AH_ERR2OUT	R/W	0	<b>Amplitude High Error to Output Register</b> b0: Do not report Amplitude High errors in the DATAx registers. b1: Report Amplitude High errors in the DATAx.ERR_AEx register field corresponding to the channel that generated the error.
11	AL_ERR2OUT	R/W	0	<b>Amplitude Low Error to Output Register</b> b0: Do not report Amplitude High errors in the DATAx registers. b1: Report Amplitude High errors in the DATAx.ERR_AEx register field corresponding to the channel that generated the error.
10:8	Reserved	R/W	00	Reserved. Set to b00.
7	UR_ERR2INT	R/W	0	<b>Under-range Error to INTB</b> b0: Do not report Under-range errors by asserting INTB pin and STATUS register. b1: Report Under-range errors by asserting INTB pin and updating STATUS.ERR_UR register field.
6	OR_ERR2INT	R/W	0	<b>Over-range Error to INTB</b> b0: Do not report Over-range errors by asserting INTB pin and STATUS register. b1: Report Over-range errors by asserting INTB pin and updating STATUS.ERR_OR register field.
5	WD_ERR2INT	R/W	0	<b>Watchdog Timeout Error to INTB</b> b0: Do not report Watchdog errors by asserting INTB pin and STATUS register. b1: Report Watchdog Timeout errors by asserting INTB pin and updating STATUS.ERR_WD register field.
4	AH_ERR2INT	R/W	0	<b>Amplitude High Error to INTB</b> b0: Do not report Amplitude High errors by asserting INTB pin and STATUS register. b1: Report Amplitude High errors by asserting INTB pin and updating STATUS.ERR_AHE register field.
3	AL_ERR2INT	R/W	0	<b>Amplitude Low Error to INTB</b> b0: Do not report Amplitude Low errors by asserting INTB pin and STATUS register. b1: Report Amplitude Low errors by asserting INTB pin and updating STATUS.ERR_ALE register field.

**Table 22. Address 0x19, ERROR\_CONFIG (continued)**

Bit	Field	Type	Reset	Description
2	ZC_ERR2INT	R/W	0	<b>Zero Count Error to INTB</b> b0: Do not report Zero Count errors by asserting INTB pin and STATUS register. b1: Report Zero Count errors by asserting INTB pin and updating STATUS. ERR_ZC register field.
1	Reserved	R/W	0	Reserved. Set to b0.
0	DRDY_2INT	R/W	0	<b>Data Ready Flag to INTB</b> b0: Do not report Data Ready Flag by asserting INTB pin and STATUS register. b1: Report Data Ready Flag by asserting INTB pin and updating STATUS. DRDY register field.

**7.6.24 Address 0x1A, CONFIG**
**Figure 37. Address 0x1A, CONFIG**

15	14	13	12	11	10	9	8
ACTIVE_CHAN		SLEEP_MODE_EN	RP_OVERRID E_EN	SENSOR_ACTI VATE_SEL	AUTO_AMP_DI S	REF_CLK_SR C	RESERVED
7	6	5	4	3	2	1	0
INTB_DIS	HIGH_CURRE NT_DRV	RESERVED					

LEGEND: R/W = Read/Write; R = Read only; -n = value after reset

**Table 23. Address 0x1A, CONFIG Field Descriptions**

Bit	Field	Type	Reset	Description
15:14	ACTIVE_CHAN	R/W	00	<b>Active Channel Selection</b> Selects channel for continuous conversions when MUX_CONFIG.AUTOSCAN_EN is 0. b00: Perform continuous conversions on Channel 0 b01: Perform continuous conversions on Channel 1 b10: Perform continuous conversions on Channel 2 (LDC1314 only) b11: Perform continuous conversions on Channel 3 (LDC1314 only)
13	SLEEP_MODE_EN	R/W	1	<b>Sleep Mode Enable</b> Enter or exit low power Sleep Mode. b0: Device is active. b1: Device is in Sleep Mode.
12	RP_OVERRIDE_EN	R/W	0	<b>Sensor R<sub>p</sub> Override Enable</b> Provides control over Sensor current drive used during the conversion time for Ch. x, based on the programmed value in the IDRIVEx field. Refer to <a href="#">Automatic IDRIVE Setting with RP_OVERRIDE_EN</a> for details. b0: Override off b1: R <sub>p</sub> Override on
11	SENSOR_ACTIVATE_SEL	R/W	1	<b>Sensor Activation Mode Selection</b> Set the mode for sensor initialization. Refer to <a href="#">Sensor Activation</a> for details. b0: Full Current Activation Mode – the LDC will drive maximum sensor current for a shorter sensor activation time. b1: Low Power Activation Mode – the LDC uses the value programmed in DRIVE_CURRENTx during sensor activation to minimize power consumption.
10	AUTO_AMP_DIS	R/W	0	<b>Automatic Sensor Amplitude Correction Disable</b> Setting this bit will disable the automatic Amplitude correction algorithm and stop the updating of the INIT_IDRIVEx field. b0: Automatic Amplitude correction enabled. b1: Automatic Amplitude correction is disabled. Recommended for precision applications.

**Table 23. Address 0x1A, CONFIG Field Descriptions (continued)**

Bit	Field	Type	Reset	Description
9	REF_CLK_SRC	R/W	0	<b>Select Reference Frequency Source</b> b0: Use Internal oscillator as reference frequency. b1: Reference frequency is provided from CLKIN pin.
8	RESERVED	R/W	0	Reserved. Set to b0.
7	INTB_DIS	R/W	0	<b>INTB Disable</b> b0: INTB pin will be asserted when status register updates. b1: INTB pin will not be asserted when status register updates. If this mode is selected, the INTB pin level will be high.
6	HIGH_CURRENT_DRV	R/W	0	<b>High Current Sensor Drive</b> b0: The LDC will drive all channels with normal sensor current (1.5mA max). b1: The LDC will drive channel 0 with current >1.5mA. This mode is not supported if AUTOSCAN_EN = b1 (multi-channel mode).
5:0	RESERVED	R/W	00 0001	Reserved. Set to b00'0001.

### 7.6.25 Address 0x1B, MUX\_CONFIG

**Figure 38. Address 0x1B, MUX\_CONFIG**

15	14	13	12	11	10	9	8
AUTOSCAN_EN	RR_SEQUENCE		RESERVED				
7	6	5	4	3	2	1	0
RESERVED					DEGLITCH		

LEGEND: R/W = Read/Write; R = Read only; -n = value after reset

**Table 24. Address 0x1B, MUX\_CONFIG Field Descriptions**

Bit	Field	Type	Reset	Description
15	AUTOSCAN_EN	R/W	0	<b>Auto-Scan Mode Enable</b> b0: Continuous conversion on the single channel selected by CONFIG.ACTIVE_CHAN register field. b1: Auto-Scan conversions as selected by MUX_CONFIG.RR_SEQUENCE register field.
14:13	RR_SEQUENCE	R/W	00	<b>Auto-Scan Sequence Configuration</b> Configure multiplexing channel sequence. The LDC will perform a single conversion on each channel in the sequence selected, and then restart the sequence continuously. b00: Ch0, Ch1 b01: Ch0, Ch1, Ch2 (LDC1314 only) b10: Ch0, Ch1, Ch2, Ch3 (LDC1314 only) b11: Ch0, Ch1
12:3	RESERVED	R/W	00 0100 0001	Reserved. Set to 00 0100 0001.
2:0	DEGLITCH	R/W	111	<b>Input Deglitch Filter Bandwidth</b> Select the lowest setting that exceeds the maximum sensor oscillation frequency. b001: 1.0 MHz b100: 3.3 MHz b101: 10 MHz b111: 33 MHz

### 7.6.26 Address 0x1C, RESET\_DEV

**Figure 39. Address 0x1C, RESET\_DEV**

15	14	13	12	11	10	9	8
RESET_DEV	RESERVED				OUTPUT_GAIN		RESERVED
7	6	5	4	3	2	1	0
RESERVED							

LEGEND: R/W = Read/Write; R = Read only; -n = value after reset

**Table 25. Address 0x1C, RESET\_DEV Field Descriptions**

Bit	Field	Type	Reset	Description
15	RESET_DEV	R/W	0	<b>Device Reset</b> Write b1 to reset the device. Will always readback 0.
14:11	RESERVED	R/W	0000	Reserved. Set to b0000.
10:9	OUTPUT_GAIN	R/W	00	<b>Output Gain Control</b> 00: Gain = 1 (0 bits shift) 01: Gain = 4 (2 bits shift) 10: Gain = 8 (3 bits shift) 11: Gain = 16 (4 bits shift)
8:0	RESERVED	R/W	0x000	Reserved. Set to b0 0000 0000.

**7.6.27 Address 0x1E, DRIVE\_CURRENT0**
**Figure 40. Address 0x1E, DRIVE\_CURRENT0**

15	14	13	12	11	10	9	8
IDRIVE0					INIT_IDRIVE0		
7	6	5	4	3	2	1	0
INIT_IDRIVE0		RESERVED					

LEGEND: R/W = Read/Write; R = Read only; -n = value after reset

**Table 26. Address 0x1E, DRIVE\_CURRENT0 Field Descriptions**

Bit	Field	Type	Reset	Description
15:11	IDRIVE0	R/W	0 0000	<b>Channel 0 L-C Sensor Drive Current</b> This field sets the Sensor Drive Current used during the settling + conversion time of Channel 0 sensor. RP_OVERRIDE_EN bit must be set to 1.
10:6	INIT_IDRIVE0	R	0 0000	<b>Channel 0 Sensor Current Drive</b> This field stores the Initial Drive Current measured during the initial Amplitude Calibration phase. It is updated after each Amplitude Correction phase of the sensor conversion if AUTO_AMP_DIS=0. When writing to DRIVE_CURRENT0, set this field to b0 0000.
5:0	RESERVED	R/W	00 0000	Reserved. Set to b00 0000

**7.6.28 Address 0x1F, DRIVE\_CURRENT1**
**Figure 41. Address 0x1F, DRIVE\_CURRENT1**

15	14	13	12	11	10	9	8
IDRIVE1					INIT_IDRIVE1		
7	6	5	4	3	2	1	0
INIT_IDRIVE1		RESERVED					

LEGEND: R/W = Read/Write; R = Read only; -n = value after reset

**Table 27. Address 0x1F, DRIVE\_CURRENT1 Field Descriptions**

Bit	Field	Type	Reset	Description
15:11	IDRIVE1	R/W	0 0000	<b>Channel 1 L-C Sensor Drive Current</b> This field sets the Sensor Drive Current used during the settling + conversion time of Channel 0 sensor. RP_OVERRIDE_EN bit must be set to 1.
10:6	INIT_IDRIVE1	R	0 0000	<b>Channel 1 Sensor Current Drive</b> This field stores the Initial Drive Current calculated during the initial Amplitude Calibration phase. It is updated after each Amplitude Correction phase of the sensor conversion if AUTO_AMP_DIS=0. When writing to DRIVE_CURRENT1, set this field to b0 0000.
5:0	RESERVED	-	00 0000	Reserved

**7.6.29 Address 0x20, DRIVE\_CURRENT2 (LDC1314 only)**
**Figure 42. Address 0x20, DRIVE\_CURRENT2**

15	14	13	12	11	10	9	8
IDRIVE2					INIT_IDRIVE2		
7	6	5	4	3	2	1	0
INIT_IDRIVE2		RESERVED					

LEGEND: R/W = Read/Write; R = Read only; -n = value after reset

**Table 28. Address 0x20, DRIVE\_CURRENT2 Field Descriptions**

Bit	Field	Type	Reset	Description
15:11	IDRIVE2	R/W	0 0000	<b>Channel 2 L-C Sensor Drive Current</b> This field sets the Sensor Drive Current used during the settling + conversion time of Channel 0 sensor. RP_OVERRIDE_EN bit must be set to 1.
10:6	INIT_IDRIVE2	R	0 0000	<b>Channel 2 Sensor Current Drive</b> This field stores the Initial Drive Current calculated during the initial Amplitude Calibration phase. It is updated after each Amplitude Correction phase of the sensor conversion if AUTO_AMP_DIS=0. When writing to DRIVE_CURRENT2, set this field to b0 0000.
5:0	RESERVED	-	00 0000	Reserved

**7.6.30 Address 0x21, DRIVE\_CURRENT3 (LDC1314 only)**
**Figure 43. Address 0x21, DRIVE\_CURRENT3**

15	14	13	12	11	10	9	8
IDRIVE3					INIT_IDRIVE3		
7	6	5	4	3	2	1	0
INIT_IDRIVE3		RESERVED					

LEGEND: R/W = Read/Write; R = Read only; -n = value after reset

**Table 29. DRIVE\_CURRENT3 Field Descriptions**

Bit	Field	Type	Reset	Description
15:11	IDRIVE3	R/W	0 0000	<b>Channel 3 L-C Sensor Drive Current</b> This field sets the Sensor Drive Current used during the settling + conversion time of Channel 0 sensor. RP_OVERRIDE_EN bit must be set to 1.
10:6	INIT_IDRIVE3	R	0 0000	<b>Channel 3 Sensor Current Drive</b> This field stores the Initial Drive Current calculated during the initial Amplitude Calibration phase. It is updated after each Amplitude Correction phase of the sensor conversion if AUTO_AMP_DIS = 0. When writing to DRIVE_CURRENT3, set this field to b0 0000.
5:0	RESERVED	–	00 0000	Reserved

**7.6.31 Address 0x7E, MANUFACTURER\_ID**
**Table 30. Address 0x7E, MANUFACTURER\_ID Field Descriptions**

Bit	Field	Type	Reset	Description
15:0	MANUFACTURER_ID	R	0101 0100 0100 1001	Manufacturer ID = 0x5449

**7.6.32 Address 0x7F, DEVICE\_ID**
**Figure 44. Address 0x7F, DEVICE\_ID**

15	14	13	12	11	10	9	8
DEVICE_ID							
7	6	5	4	3	2	1	0
DEVICE_ID							

LEGEND: R/W = Read/Write; R = Read only; -n = value after reset

**Table 31. Address 0x7F, DEVICE\_ID Field Descriptions**

Bit	Field	Type	Reset	Description
7:0	DEVICE_ID	R	0011 0000 0101 0100	Device ID = 0x3054

## 8 Application and Implementation

### NOTE

Information in the following applications sections is not part of the TI component specification, and TI does not warrant its accuracy or completeness. TI's customers are responsible for determining suitability of components for their purposes. Customers should validate and test their design implementation to confirm system functionality.

### 8.1 Application Information

#### 8.1.1 Conductive Objects in a Time-Varying EM Field

An AC current flowing through an inductor will generate an AC magnetic field. If a conductive material, such as a metal object, is brought into the vicinity of the inductor, the magnetic field will induce a circulating current (eddy current) on the surface of the conductor.

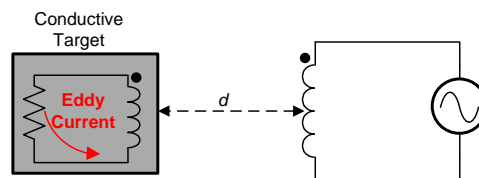
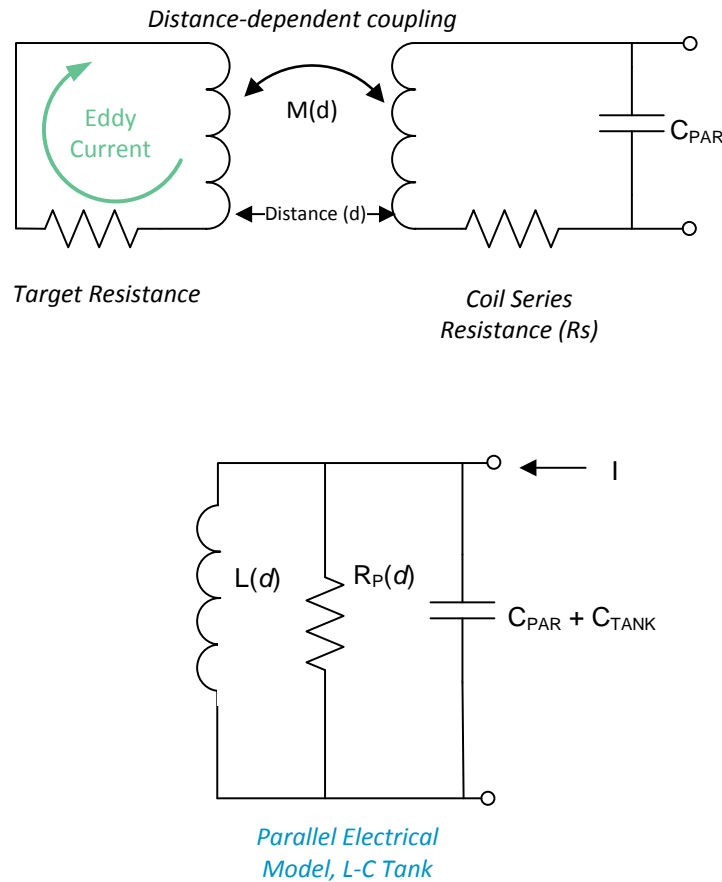

**Figure 45. Conductor in AC Magnetic Field**

The eddy current is a function of the distance, size, and composition of the conductor. The eddy current generates its own magnetic field, which opposes the original field generated by the sensor inductor. This effect is equivalent to a set of coupled inductors, where the sensor inductor is the primary winding and the eddy current in the target object represents the secondary inductor. The coupling between the inductors is a function of the sensor inductor, and the resistivity, distance, size, and shape of the conductive target. The resistance and inductance of the secondary winding caused by the eddy current can be modeled as a distance dependent resistive and inductive component on the primary side (coil). [Figure 45](#) shows a simplified circuit model of the sensor and the target as coupled coils.

#### 8.1.2 L-C Resonators

An EM field can be generated using an L-C resonator, or L-C tank. One topology for an L-C tank is a parallel R-L-C construction, as shown in [Figure 46](#).

**Application Information (continued)**

Copyright © 2016, Texas Instruments Incorporated

**Figure 46. Electrical Model of the L-C Tank Sensor**

A resonant oscillator can be constructed by combining a frequency selective circuit (resonator) with a gain block in a closed loop. The criteria for oscillation are: (1) loop gain > 1, and (2) closed loop phase shift of  $2\pi$  radians. The R-L-C resonator provides the frequency selectivity and contributes to the phase shift. At the resonance frequency, the impedance of the reactive components (L and C) cancels, leaving only  $R_P$ , the lossy (resistive) element in the circuit. The voltage amplitude is maximized at this frequency. The  $R_P$  can be used to determine the sensor drive current for a given oscillation amplitude. A lower  $R_P$  requires a larger sensor current to maintain a constant oscillation amplitude. The sensor oscillation frequency is given by:

$$f_{\text{SENSOR}} = \frac{1}{2\pi\sqrt{LC}} * \sqrt{1 - \frac{1}{Q^2} - \frac{5 * 10^{-9}}{Q\sqrt{LC}}} \approx \frac{1}{2\pi\sqrt{LC}}$$

where:

- C is the sensor capacitance ( $C_{\text{SENSOR}} + C_{\text{PARASITIC}}$ )
- L is the sensor inductance

(1)

The value of Q can be calculated by:

$$Q = R_P \sqrt{\frac{C}{L}}$$

where:

- $R_P$  is the AC parallel resistance of the LC resonator at the operating frequency

(2)

**Application Information (continued)**

Texas Instruments' WEBENCH design tool can be used for coil design, in which the parameter values for  $R_p$ ,  $L$  and  $C$  are calculated. See <http://www.ti.com/webench>.

$R_p$  is a function of target distance, target material, and sensor characteristics. Figure 47 shows an example of  $R_p$  variation based on the distance between the sensor and the target. The graph represents a 14 mm diameter PCB coil (23 turns, 4 mil trace width, 4 mil spacing between traces, 1 oz. copper thickness, on FR4 material). This curve is a typical response where the target distance scales based on the sensor size and the sensor  $R_p$  scales based on the free-space of the inductor.



**Figure 47. Example  $R_p$  vs. Distance with a 14 mm PCB Coil and 2 mm Thick Stainless Steel Target**

It is important to configure the sensor current drive so that the sensor will still oscillate at the minimum  $R_p$  value (which typically occurs with maximum target interaction). As an example, if the closest target distance in a system with the response shown in Figure 47 is 1mm, then the sensor current drive needs to support a  $R_p$  value is 5 kΩ. Both the minimum and maximum  $R_p$  conditions should have oscillation amplitudes that are within the device operating range. See section [Sensor Current Drive Control](#) for details on setting the current drive.

The inductance that is measured by the LDC is:

$$L(d) = L_{inf} - M(d) = \frac{1}{(2\pi * f_{SENSOR})^2 * C}$$

where:

- $L(d)$  is the measured sensor inductance, for a distance  $d$  between the sensor coil and target
- $L_{inf}$  is the inductance of the sensing coil without a conductive target (target at infinite distance)
- $M(d)$  is the mutual inductance
- $f_{SENSOR}$  = sensor oscillation frequency for a distance  $d$  between the sensor coil and target
- $C = C_{SENSOR} + C_{PARASITIC}$  (3)

Figure 48 shows an example of variation in sensor frequency and inductance as a function of distance for a 14 mm diameter PCB coil (23 turns, 4 mil trace width, 4 mil spacing between traces, 1 oz copper thickness, FR4 material). The frequency and inductance graphs will scale based on the sensor free-space characteristics, and the target distance scales based on the sensor diameter.

**Application Information (continued)**

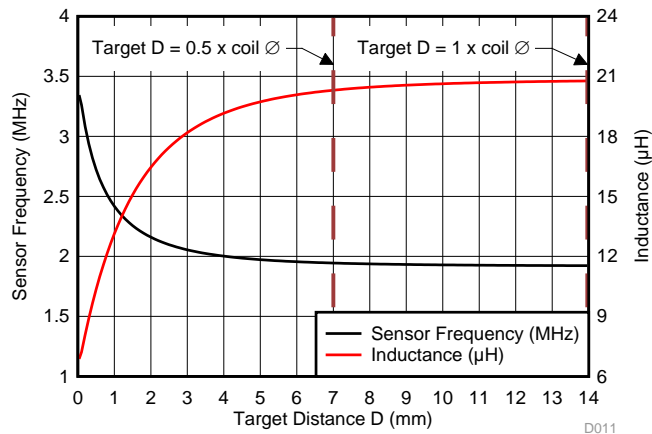

**Figure 48. Example Sensor Frequency, Inductance vs. Target Distance with 14 mm PCB Coil and 1.5 mm Thick Aluminum Target**

The Texas Instruments Application Notes [LDC Sensor Design](#) and [LDC Target Design](#) provide more information on construction of sensors and targets characteristics to consider based on system requirements.

**8.1.3 Multi-Channel and Single Channel Operation**

The multi-channel package of the LDC enables the user to save board space and support flexible system design. For example, temperature drift can often cause a shift in component values, resulting in a shift in resonant frequency of the sensor. Using a second sensor as a reference or in a differential configuration provides the capability to cancel out temperature shifts and other environmental variations. When operated in multi-channel mode, the LDC sequentially samples the selected channels - only one channel is active at any time while the other selected channels are held in an inactive state. In single channel mode, the LDC samples a single channel, which is selectable. Refer to [Inactive Channel Sensor Connections](#) for more details on inactive channels.

Inactive channels have the corresponding INAx and INBx pins tied to ground. The following table shows the registers and values that are used to configure either multi-channel or single channel modes.

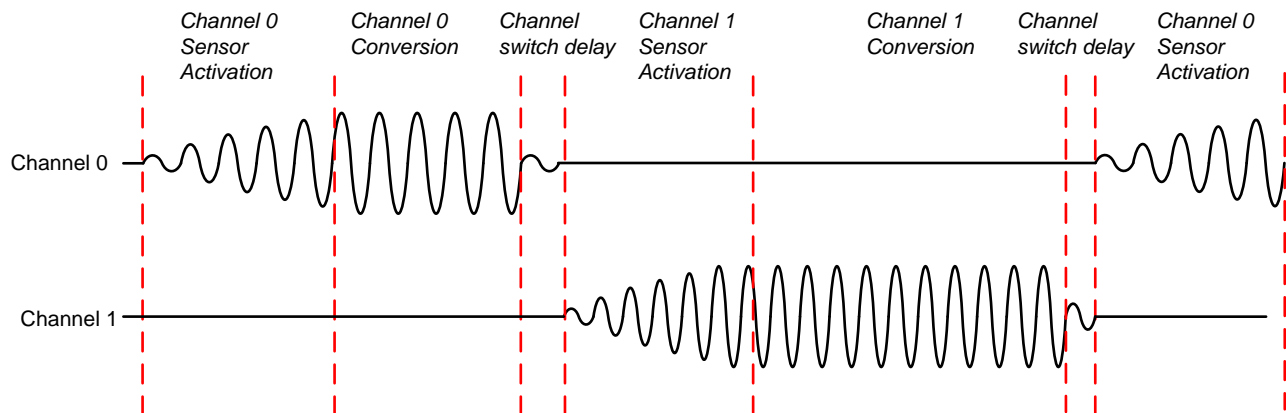

**Figure 49. Multi-Channel Mode Sequencing**

Application Information (continued)

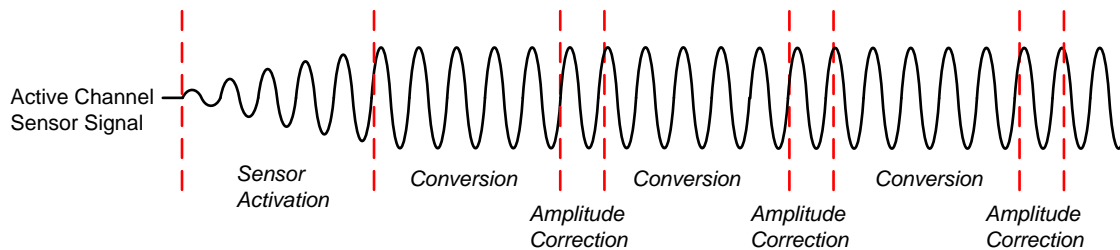

Figure 50. Single-Channel Mode Sequencing

Table 32. Single and Multi-Channel Configuration Registers

MODE	REGISTER	FIELD	VALUE <sup>(1)</sup>
Single channel	CONFIG, addr 0x1A	ACTIVE_CHAN [15:14]	00 = chan 0 01 = chan 1 10 = chan 2 11 = chan 3
	MUX_CONFIG addr 0x1B	AUTOSCAN_EN [15]	0 = continuous conversion on a single channel (default)
Multi-channel	MUX_CONFIG addr 0x1B	AUTOSCAN_EN [15]	1 = continuous conversion on multiple channels
	MUX_CONFIG addr 0x1B	RR_SEQUENCE [14:13]	00 = Ch0, Ch 1 01 = Ch0, Ch 1, Ch 2 10 = Ch0, CH1, Ch2, Ch3

(1) Channels 2 and 3 are only available for LDC1314

The digitized sensor measurement for each channel (DATA<sub>x</sub>) represents the ratio of the sensor frequency to the reference frequency. The data outputs represent the 12 MSBs of a 16-bit result. With the FIN\_DIVIDER set to 1 and OFFSET set to 0, the sensor frequency can be calculated from:

$$f_{\text{sensorx}} = \frac{\text{DATA}_x * f_{\text{REFx}}}{2^{12}} \tag{4}$$

The following table illustrates the registers that contain the fixed point sample values for each channel.

Table 33. LDC1314/1312 Sample Data Registers

CHANNEL <sup>(1)</sup>	REGISTER	FIELD NAME [BITS(S) ]	VALUE
0	DATA0, addr 0x00	DATA0 [11:0]	12 bit conversion results 0x000 = sensor under range condition 0xff = sensor over range condition
1	DATA1, addr 0x02	DATA1 [11:0]	12 bit conversion results. 0x000 = sensor under range condition 0xff = sensor over range condition
2	DATA2, addr 0x04	DATA2 [11:0]	12 bit conversion result. 0x000 = sensor under range condition 0xff = sensor over range condition

(1) Channels 2 and 3 available for LDC1314 only.

**Table 33. LDC1314/1312 Sample Data Registers (continued)**

CHANNEL <sup>(1)</sup>	REGISTER	FIELD NAME [BITS(S) ]	VALUE
3	DATA3, addr 0x06	DATA3 [11:0]	12 bit conversion result. 0x000 = sensor under range condition 0xff = sensor over range condition

$$\text{DATA}_x = \text{DATA}_x\_MSB \times 65536 + \text{DATA}_x\_LSB \quad (5)$$

### 8.1.3.1 Data Offset

An offset value may be subtracted from each DATA value to compensate for a frequency offset or maximize the dynamic range of the sample data. The offset values should be  $< f_{\text{SENSOR}_x\_MIN} / f_{\text{REF}_x}$ . Otherwise, the offset might be so large that it masks the LSBs which are changing.

**Table 34. Frequency Offset Registers**

CHANNEL <sup>(1)</sup>	REGISTER	FIELD [ BIT(S) ]	VALUE
0	OFFSET0, addr 0x0C	OFFSET0 [ 15:0 ]	$f_{\text{OFFSET0}} = \text{OFFSET0} \times (f_{\text{REF0}}/2^{16})$
1	OFFSET1, addr 0x0D	OFFSET1 [ 15:0 ]	$f_{\text{OFFSET1}} = \text{OFFSET1} \times (f_{\text{REF1}}/2^{16})$
2	OFFSET2, addr 0x0E	OFFSET2 [ 15:0 ]	$f_{\text{OFFSET2}} = \text{OFFSET2} \times (f_{\text{REF2}}/2^{16})$
3	OFFSET3, addr 0x0F	OFFSET3 [ 15:0 ]	$f_{\text{OFFSET3}} = \text{OFFSET3} \times (f_{\text{REF3}}/2^{16})$

The sensor frequency can be determined by:

$$f_{\text{SENSOR}_x} = \text{CH}_x\_FIN\_DIVIDER * f_{\text{REF}_x} \left( \frac{\text{DATA}_x}{2^{(12+\text{OUTPUT\_GAIN})}} + \frac{\text{CH}_x\_OFFSET}{2^{16}} \right)$$

where:

- DATA<sub>x</sub> = Conversion result from the DATA<sub>x</sub> register
- OFFSET<sub>x</sub> = Offset value set in the OFFSET<sub>x</sub> register
- OUTPUT\_GAIN = output multiplication factor set in the RESET\_DEVICE.OUTPUT\_GAIN register

### 8.1.3.2 Digital Signal Gain

Internally, the LDC measures inductance shifts with 16 bits of resolution, while the conversion output word width is only 12 bits. For systems in which the sensor signal variation is less than 25% of the full scale range, the LDC can report conversion results with higher resolution by setting the Output Gain. The Output Gain is applied to all device channels. An output gain can be used to apply a 2-bit, 3-bit, or 4-bit shift to the output code for all channels, providing an effectively higher measurement resolution. When the Gain function is used, additional LSBs of the conversion word are reported, while the corresponding number of MSBs are not reported.

To avoid data corruption issues, use the Output Gain function ([Data Offset](#)) to shift the output codes to prevent toggling of the shifted MSBs.

**Table 35. Output Gain Register**

CHANNEL <sup>(1)</sup>	REGISTER	FIELD [ BIT(S) ]	VALUES	EFFECTIVE RESOLUTION (BITS)	OUTPUT RANGE
All	RESET_DEV, addr 0x1C	OUTPUT_GAIN [ 10:9 ]	00 (default): Gain =1 (0 bits shift)	12	100% full scale
			01: Gain = 4 (2 bits left shift)	14	25% full scale
			10: Gain = 8 (3 bits left shift)	15	12.5% full scale
			11 : Gain = 16 (4 bits left shift)	16	6.25% full scale

(1) Channels 2 and 3 are only available for LDC1314

(1) Channels 2 and 3 are available for LDC1314 only.

**Example:** If the conversion result for a channel is 0x07A3, with OUTPUT\_GAIN=0x0, the reported output code is 0x07A. If OUTPUT\_GAIN is set to 0x3 in the same condition, then the reported output code is 0x7A3. The original 4 MSBs (0x0) are no longer accessible. Figure 51 illustrates the segments of the 16-bit sample that is reported for each possible gain setting.

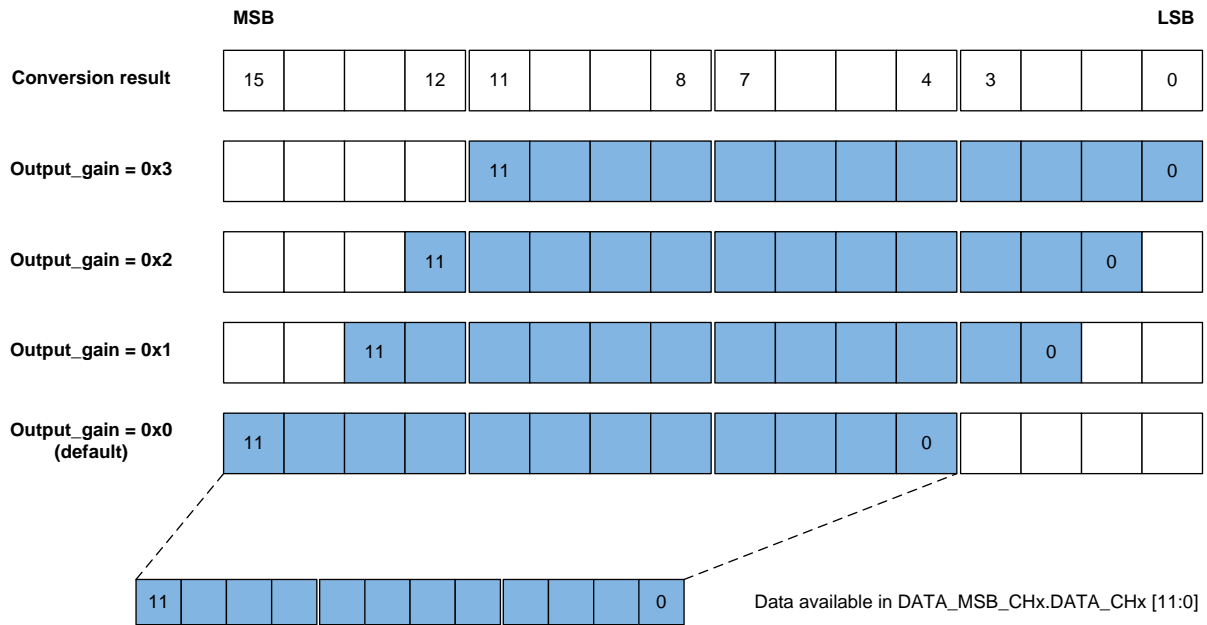

Figure 51. Conversion Data Output Gain

### 8.1.4 Sensor Conversion Time

The LDC1312/LDC1314 provides a configurable conversion time by setting an internal register. The conversion interval can be configured across a range of 1.2 μs to >26.2 ms with 16 bits of resolution. Note that it is possible to configure the conversion interval to be significantly shorter than the time required to readback the DATAx registers; when configured in this manner, older conversions for a channel are overwritten when new conversion data is completed for each channel. The conversion interval is set in multiples of the reference clock period by setting the RCOUNTx register value. The conversion time for any channel x is:

$$t_{Cx} = (RCOUNTx \times 16 + 4) / f_{REFx} \tag{7}$$

In general, a longer conversion time will provide a higher resolution inductance measurement. The reference count value should be chosen to support both the required sample rate and the necessary resolution. Refer to the TI Application Note [Optimizing L Measurement Resolution for the LDC1312 and LDC1314](#) for more information.

Table 36. Conversion Time Configuration Registers, Channels 0 - 3<sup>(1)</sup>

CHANNEL	REGISTER	FIELD	CONVERSION TIME
0	RCOUNT0, addr 0x08	RCOUNT0 [15:0]	(RCOUNT0×16)/f <sub>REF0</sub>
1	RCOUNT1, addr 0x09	RCOUNT1 [15:0]	(RCOUNT1×16)/f <sub>REF1</sub>
2	RCOUNT2, addr 0x0A	RCOUNT2 [15:0]	(RCOUNT2×16)/f <sub>REF2</sub>
3	RCOUNT3, addr 0x0B	RCOUNT3 [15:0]	(RCOUNT3×16)/f <sub>REF3</sub>

(1) Channels 2 and 3 are available only for LDC1314.

The typical channel switch delay time between the end of conversion and the beginning of sensor activation of the subsequent channel is:

$$\text{Channel Switch Delay} = 692 \text{ ns} + 5 / f_{ref} \tag{8}$$

The deterministic conversion time of the LDC allows data polling at a fixed interval. A data ready flag (DRDY) can assert the INTB pin for use in interrupt driven system designs (see the STATUS register description in [Register Maps](#)).

### 8.1.4.1 Settling Time

When the LDC sequences through the channels in multi-channel mode, the dwell time interval for each channel is the sum of 3 parts: sensor activation time + conversion time + channel switch delay.

The sensor activation time is the amount of settling time required for the sensor oscillation amplitude to stabilize, as shown in [Figure 49](#). The settling wait time is programmable and should be set to a value that is long enough to allow stable oscillation. The settling wait time for channel x is given by:

$$t_{Sx} = (\text{SETTLECOUNTx} \times 16) / f_{\text{REFx}} \quad (9)$$

[Table 37](#) illustrates the registers and values for configuring the settling time for each channel.

**Table 37. Settling Time Register Configuration**

CHANNEL <sup>(1)</sup>	REGISTER	FIELD	CONVERSION TIME <sup>(2)</sup>
0	SETTLECOUNT0, addr 0x10	SETTLECOUNT0 [15:0]	(SETTLECOUNT0×16)/f <sub>REF0</sub>
1	SETTLECOUNT1, addr 0x11	SETTLECOUNT1 [15:0]	(SETTLECOUNT1×16)/f <sub>REF1</sub>
2	SETTLECOUNT2, addr 0x12	SETTLECOUNT2 [15:0]	(SETTLECOUNT2×16)/f <sub>REF2</sub>
3	SETTLECOUNT3, addr 0x13	SETTLECOUNT3 [15:0]	(SETTLECOUNT3×16)/f <sub>REF3</sub>

(1) Channels 2 and 3 are available only in the LDC1314.

(2)  $f_{\text{REFx}}$  is the reference frequency configured for the channel.

The SETTLECOUNTx for any channel x must satisfy:

$$\text{SETTLECOUNTx} \geq Q_{\text{SENSORx}} \times f_{\text{REFx}} / (16 \times f_{\text{SENSORx}})$$

where:

- $f_{\text{SENSORx}}$  = Sensor Frequency of Channel x
- $f_{\text{REFx}}$  = Reference frequency for Channel x
- $Q_{\text{SENSORx}}$  = Quality factor of the sensor on Channel x. The sensor Q can be calculated with: (10)

$$Q = R_p \sqrt{\frac{C}{L}} \quad (11)$$

Round the result to the next highest integer (for example, if [Equation 10](#) recommends a minimum value of 6.08, program the register to 7 or higher).

L,  $R_p$  and C values can be obtained by using Texas Instrument's [WEBENCH®](#) for the coil design.

### 8.1.4.2 Sensor Activation

The LDC1312/LDC1314 provides option to either reduce the sensor activation time or to reduce the device current consumption during the sensor activation time.

This can reduce the sensor activation time for higher-Q sensors by driving the maximum sensor drive current during the sensor settling time. The maximum sensor drive current is nominally 1.56 mA. Sensors already configured to use the maximum drive current setting (IDRIVEx = b11111) will see no change in operation based on this setting.

This mode is selected by setting SENSOR\_ACTIVATE\_SEL to 0.

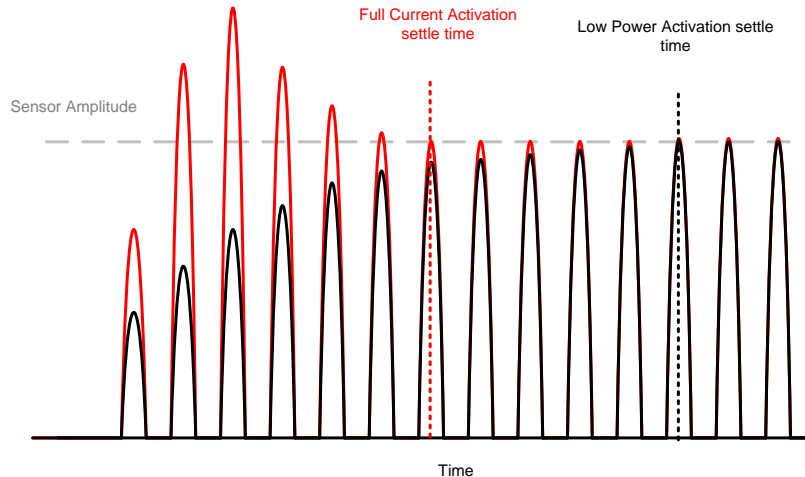

Figure 52. Sensor Full Current Activation vs. Low Power Activation

### 8.1.5 Sensor Current Drive Configuration

The registers listed in [Table 38](#) are used to control the sensor drive current so that the sensor signal amplitude is within the optimum range of  $1.2 V_P$  to  $1.8 V_P$  (sensor amplitudes outside this optimum range can be reported in the status register - refer to [Device Status Registers](#)). The device can still convert with sensor amplitudes lower than  $0.6 V_P$ , however the conversion noise will increase with lower sensor amplitudes. Below  $0.6 V_P$  the sensor oscillations may not be stable or may completely stop and the LDC will stop converting. If the current drive results in the oscillation amplitude greater than  $1.8 V$ , the internal ESD clamping circuit will become active. This may cause the sensor frequency to shift so that the output values no longer represent a valid system state. [Figure 53](#) shows the block diagram of the sensor driver. Each channel has an independent setting for the IDRIVE current used to set the sensor oscillation amplitude.

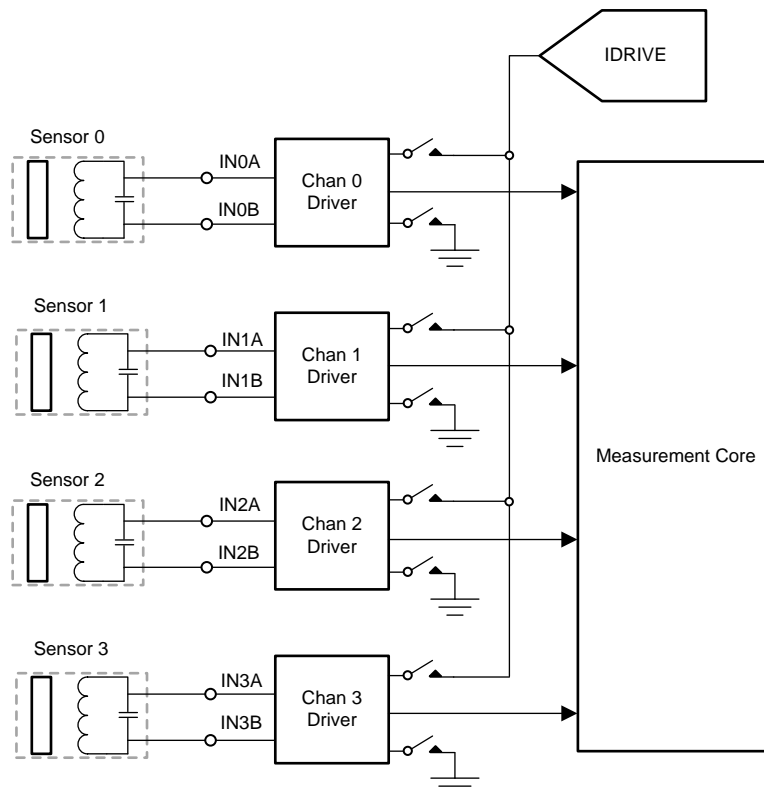

Figure 53. LDC1314 Sensor Driver Block Diagram

**Table 38. Current Drive Control Registers**

CHANNEL <sup>(1)</sup>	REGISTER	FIELD [ BIT(S) ]	VALUE
All	CONFIG, addr 0x1A	SENSOR_ACTIVATE_SEL [11]	Sets current drive for sensor activation. Recommended value is b0 (Full Current mode).
		RP_OVERRIDE_EN [12]	Set to b1 for normal operation (RP Override enabled)
		AUTO_AMP_DIS [10]	Disables Automatic amplitude correction. Set to b1 for normal operation (disabled)
0	CONFIG, addr 0x1A	HIGH_CURRENT_DRV [6]	b0 = normal current drive (1.5 mA) b1 = Increased current drive (> 1.5 mA) for Ch 0 in single channel mode only. Cannot be used in multi-channel mode.
0	DRIVE_CURRENT0, addr 0x1E	IDRIVE0 [15:11]	Drive current used during the settling and conversion time for Ch. 0 (auto-amplitude correction must be disabled and RP override=1 )
		INIT_IDRIVE0 [10:6]	Initial drive current stored during auto-calibration. Not used for normal operation.
1	DRIVE_CURRENT1, addr 0x1F	IDRIVE1 [15:11]	Drive current used during the settling and conversion time for Ch. 1 (auto-amplitude correction must be disabled and RP override=1 )
		INIT_IDRIVE1 [10:6]	Initial drive current stored during auto-calibration. Not used for normal operation.
2	DRIVE_CURRENT2, addr 0x20	IDRIVE2 [15:11]	Drive current used during the settling and conversion time for Ch. 2 (auto-amplitude correction must be disabled and RP override=1 )
		INIT_IDRIVE2 [10:6]	Initial drive current stored during auto-calibration. Not used for normal operation.
3	DRIVE_CURRENT3, addr 0x21	IDRIVE3 [15:11]	Drive current used during the settling and conversion time for Ch. 3 (auto-amplitude correction must be disabled and RP override=1 )
		INIT_IDRIVE3 [10:6]	Initial drive current stored during auto-calibration. Not used for normal operation.

(1) Channels 2 and 3 are available for LDC1314 only.

If the  $R_P$  value of the sensor attached to Channel x is known, [Table 39](#) can be used to select the 5-bit value to be programmed into the IDRIVEx field for the channel. If the measured  $R_P$  (at maximum spacing between the sensor and the target) falls between two of the table values, use the current drive value associated with the lower  $R_P$  from the table. All channels that use an identical sensor/target configuration can use the same IDRIVEx value. The appropriate sensor drive current can be calculated with:

$$I_{DRIVE} = \pi V_P \div 4R_P \quad (12)$$

**Table 39. Optimum Sensor  $R_P$  Ranges for Sensor IDRIVEx Setting.**

IDRIVEx Register Field Value	Nominal Sensor Current ( $\mu$ A)	Minimum Sensor $R_P$ (k $\Omega$ )	Maximum Sensor $R_P$ (k $\Omega$ )
0	b00000	16	60.0
1	b00001	18	51.8
2	b00010	20	44.6
3	b00011	23	38.4
4	b00100	28	33.7
5	b00101	32	29.5
6	b00110	40	23.6
7	b00111	46	20.5
8	b01000	52	18.1

**Table 39. Optimum Sensor  $R_P$  Ranges for Sensor IDRIVEx Setting. (continued)**

IDRIVEx Register Field Value	Nominal Sensor Current ( $\mu\text{A}$ )	Minimum Sensor $R_P$ ( $\text{k}\Omega$ )	Maximum Sensor $R_P$ ( $\text{k}\Omega$ )
9	b01001	59	16.1
10	b01010	72	13.1
11	b01011	82	11.5
12	b01100	95	9.92
13	b01101	110	8.57
14	b01110	127	7.42
15	b01111	146	6.46
16	b10000	169	5.58
17	b10001	195	4.83
18	b10010	212	4.45
19	b10011	244	3.86
20	b10100	297	3.17
21	b10101	342	2.76
22	b10110	424	2.22
23	b10111	489	1.93
24	b11000	551	1.71
25	b11001	635	1.48
26	b11010	763	1.24
27	b11011	880	1.07
28	b11100	1017	0.93
29	b11101	1173	0.80
30	b11110	1355	0.70
31	b11111	1563	0.60

Sensors with  $R_P$  greater than 90  $\text{k}\Omega$  can be driven by placing a 100  $\text{k}\Omega$  resistor in parallel with the sensor inductor to reduce the effective  $R_P$ .

Sensors which have a wide range of  $R_P$  may require more than one current drive setting across the range of operation - the current would need to be dynamically set based on the target position. Note that some high-resolution applications will experience an output code offset when the current drive is changed. Another approach for systems which have a wide range of  $R_P$  is to place a discrete resistor in parallel with the inductor to limit the range of  $R_P$  variation in the system. This will also reduce the sensor Q, and so may not be feasible for some implementations.

#### 8.1.5.1 Inactive Channel Sensor Connections

The LDC1312/LDC1314 ties the INAx and INBx pins for all channels to ground by  $\sim 10\ \Omega$  except for the active channel; in Sleep and Shutdown modes there are no active channels and so all channels are tied to ground. By grounding the channels, potential interactions between sensors are minimized. For multi-channel sequencing, only the active channel is driven with the IDRIVE current during the conversion time; once the conversion for the specific channel completes, the sensor is tied to ground to shut off the sensor, and the next sensor is activated.

For systems which do not use all sensor channels, it is acceptable to leave the unused INAx and INBx pins No-Connect.

### 8.1.5.2 Automatic IDRIVE Setting with RP\_OVERRIDE\_EN

The LDC1312/LDC1314 can automatically determine the appropriate sensor current drive when entering Active Mode. For the majority of applications, it is recommended to program a fixed current drive for consistent measurement performance. The automatic sensor amplitude setting is useful for initial system prototyping if the sensor amplitude is unknown. When this function is enabled, the LDC attempts to find the IDRIVE<sub>x</sub> setting which results in a sensor amplitude between 1.2 V<sub>P</sub> and 1.8V<sub>P</sub>. For systems which have a large variation in target interaction, the LDC1312/LDC1314 may select a current drive setting which has poorer repeatability over the range of target interactions. In addition, measurement repeatability will be poorer with different sensor current drives. To enable the automatic sensor amplitude, set RP\_OVERRIDE to b0.

The following sequence uses auto-calibration to configure sensor drive current for a sensor with an unknown R<sub>P</sub>:

1. Set target at the maximum planned operating distance from the sensor.
2. Place the device into SLEEP mode by setting CONFIG.SLEEP\_MODE\_EN to b0.
3. Program the desired values of SETTLECOUNT and RCOUNT values for the channel.
4. Enable auto-calibration by setting RP\_OVERRIDE\_EN to b0.
5. Take the device out of SLEEP mode by setting CONFIG.SLEEP\_MODE\_EN to b1.
6. Allow the device to perform at least one measurement, with the target stable (fixed) at the maximum operating range.
7. Read the channel current drive value from the appropriate DRIVE\_CURRENT<sub>x</sub> register (addresses 0x1e, 0x1f, 0x20, or 0x21), in the INIT\_DRIVE<sub>x</sub> field (bits 10:6). Save this value.
8. During startup for normal operating mode, write the value saved from the INIT\_DRIVE<sub>x</sub> bit field into the IDRIVE<sub>x</sub> bit field (bits 15:11).
9. During normal operating mode, the RP\_OVERRIDE\_EN should be set to b1 for a fixed current drive.

If the current drive results in the oscillation amplitude greater than 1.8 V, the internal ESD clamping circuit will become active. This may cause the sensor frequency to shift so that the output values no longer represent a valid system state. If the current drive is set at a lower value, the SNR performance of the system will decrease, and at near zero target range, oscillations may completely stop, and the output sample values will be all zeroes.

If there are significant differences in the sensor construction for different channels, then this process should be repeated for each channel.

### 8.1.5.3 Determining Sensor IDRIVE for an Unknown Sensor R<sub>P</sub> Using an Oscilloscope

If the sensor R<sub>P</sub> is not known, probing the sensor amplitude with an oscilloscope can be used set IDRIVE<sub>x</sub>.

An iterative process of adjusting the drive current setting while monitoring the signal amplitude on IN<sub>Ax</sub> or IN<sub>Bx</sub> to ground is sufficient. Simply move the sensor target to the farthest planned operating distance from the sensor, and measure the channel amplitude after the amplitude has stabilized. If the sensor amplitude is less than 1.5 V<sub>P</sub>, increase the channel IDRIVE setting. If the sensor amplitude settles to greater than 1.75 V<sub>P</sub>, decrease the channel IDRIVE setting. If there are significant differences in the sensor construction for different channels, then this process should be repeated for each channel.

### 8.1.5.4 Sensor Auto-Calibration Mode

The LDC includes a sensor current Auto-calibration mode which can be dynamically set the sensor drive current. The auto-amplitude correction attempts to maintain the sensor oscillation amplitude between 1.2V and 1.8V by adjusting the sensor drive current between conversions.

This functionality is enabled by setting AUTO\_AMP\_DIS to b0, and applies to all active channels. The INIT\_IDRIVE<sub>x</sub> register field will be updated with the current drive value as the sensor current drive setting changes. The value of the INIT\_IDRIVE<sub>x</sub> register field matches the setting of the IDRIVE<sub>x</sub> register field. For example, an INIT\_IDRIVE<sub>x</sub> field with b10001 corresponds to a current drive of 195 μA.

When auto-amplitude correction is active, the output data may experience offsets in the channel output code due to adjustments in drive current. Due to these offsets, Auto-amplitude correction is generally not recommended for use in high precision applications.

### 8.1.5.5 Channel 0 High Current Drive

Channel 0 provides a high sensor current drive mode to drive sensor coils with a typical drive current >3.5 mA. This feature can be used to drive sensors with an  $R_P$  lower than 350  $\Omega$ . Set the HIGH\_CURRENT\_DRV field to b1 to enable this mode. This drive mode is only available on Channel 0, and can only be enabled in single channel mode (AUTOSCAN\_EN = 0).

### 8.1.6 Clocking Architecture

Optimum LDC1312/LDC1314 performance requires a clean reference clock with a limited frequency range. The device provides digital dividers for the  $f_{CLK}$  and the sensor inputs. The dividers provide flexibility in system design, so that the full range of sensor frequencies can be supported with available  $f_{CLK}$ . Each channel has a dedicated divider configuration. Higher reference frequencies provide a higher sample rate for a given resolution.

Figure 54 shows the clock dividers and multiplexers of the LDC.

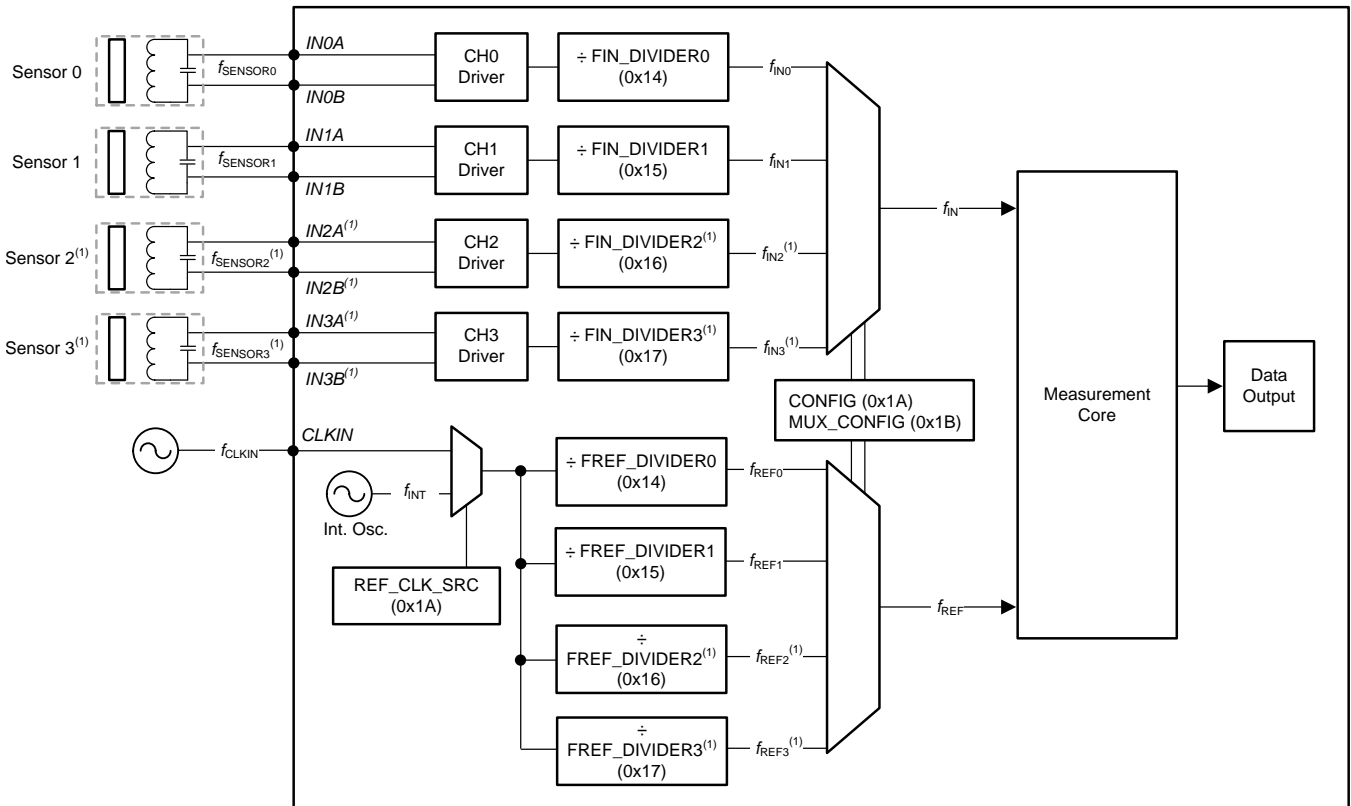

Figure 54. Clocking Diagram

(1) LDC1314 only

In Figure 54, the key clocks are  $f_{INx}$ ,  $f_{REFx}$ , and  $f_{CLK}$ .  $f_{CLK}$  is selected from either the internal clock source or external clock source (CLKIN). The frequency measurement reference clock,  $f_{REF}$ , is derived from the  $f_{CLK}$  source.

The internal oscillator is highly stable across temperature and is suitable for most LDC1312/4 applications. Applications requiring matched performance across multiple LDC1312/4 devices and/or requiring higher long-term stability may need an external oscillator. Note that some internal functions, such as watchdog timers, always use  $f_{INT}$  for timing.

The  $f_{INx}$  clock is derived from sensor frequency for channel  $x$ ,  $f_{SENSORx}$ .  $f_{REFx}$  and  $f_{INx}$  must meet the requirements listed in Table 40, depending on whether  $f_{CLK}$  (reference clock) is the internal or external clock.

**Table 40. Clock Frequency Requirements**

MODE <sup>(1)</sup>	REFERENCE SOURCE	VALID $f_{REFx}$ RANGE	VALID $f_{INx}$ RANGE	SET FIN_DIVIDERx to	VALID SETTLECOUNTx SETTINGS	VALID RCOUNTx SETTINGS
Multi-Channel	Internal	$f_{REFx} \leq 55$ MHz	$< f_{REFx} / 4$	$\geq b0001$ <sup>(2)</sup>	$> 3$	$> 8$
	External	$f_{REFx} \leq 40$ MHz				
Single-Channel	Either external or internal	$f_{REFx} \leq 35$ MHz				

(1) Channels 2 and 3 are only available for LDC1314

(2) If  $f_{SENSOR} \geq 8.75$  MHz, then FIN\_DIVIDERx must be  $\geq 2$

Table 41 shows the clock configuration registers. Each input channel has a dedicated configuration which can be set independently.

**Table 41. Clock Configuration Registers**

CHANNEL <sup>(1)</sup>	CLOCK	REGISTER	FIELD	VALUE
All	$f_{CLK}$ = Reference Clock Source	CONFIG, addr 0x1A	REF_CLK_SRC [9]	b0 = internal oscillator is used as the reference clock b1 = external clock source is used as the reference clock
0	$f_{REF0}$	CLOCK_DIVIDERS0, addr 0x14	FREF_DIVIDER0 [9:0]	$f_{REF0} = f_{CLK} / FREF\_DIVIDER0$
1	$f_{REF1}$	CLOCK_DIVIDERS1, addr 0x15	FREF_DIVIDER1 [9:0]	$f_{REF1} = f_{CLK} / FREF\_DIVIDER1$
2	$f_{REF2}$	CLOCK_DIVIDERS2, addr 0x16	FREF_DIVIDER2 [9:0]	$f_{REF2} = f_{CLK} / FREF\_DIVIDER2$
3	$f_{REF3}$	CLOCK_DIVIDERS3, addr 0x17	FREF_DIVIDER3 [9:0]	$f_{REF3} = f_{CLK} / FREF\_DIVIDER3$
0	$f_{IN0}$	CLOCK_DIVIDERS0, addr 0x14	FIN_DIVIDER0 [15:12]	$f_{IN0} = f_{SENSOR0} / FIN\_DIVIDER0$
1	$f_{IN1}$	CLOCK_DIVIDERS1, addr 0x15	FIN_DIVIDER1 [15:12]	$f_{IN1} = f_{SENSOR1} / FIN\_DIVIDER1$
2	$f_{IN2}$	CLOCK_DIVIDERS2, addr 0x16	FIN_DIVIDER2 [15:12]	$f_{IN2} = f_{SENSOR2} / FIN\_DIVIDER2$
3	$f_{IN3}$	CLOCK_DIVIDERS3, addr 0x17	FIN_DIVIDER3 [15:12]	$f_{IN3} = f_{SENSOR3} / FIN\_DIVIDER3$

(1) Channels 2 and 3 are only available for LDC1314

### 8.1.7 Input Deglitch Filter

The input deglitch filter suppresses EMI and ringing above the sensor frequency. It does not impact the conversion result as long as its bandwidth is configured to be above the maximum sensor frequency. The input deglitch filter can be configured in MUX\_CONFIG.DEGLITCH register field as shown in Table 42. This setting applies to all channels. For optimal performance, it is recommended to select the lowest setting that exceeds the highest sensor oscillation frequency for all selected channels. For example, if the maximum sensor frequency is 2.8 MHz, choose MUX\_CONFIG.DEGLITCH = b100 (3.3 MHz).

**Table 42. Input Deglitch Filter Register**

CHANNEL <sup>(1)</sup>	MUX_CONFIG.DEGLITCH REGISTER VALUE	DEGLITCH FREQUENCY
ALL	b001	1.0 MHz
ALL	b100	3.3 MHz
ALL	b101	10 MHz
ALL	b011	33 MHz

(1) Channels 2 and 3 are available for LDC1314 only.

### 8.1.8 Device Status Registers

The LDC1312/LDC1314 can monitor and report on conversion results and the status of attached sensors using the registers listed in [Table 43](#).

**Table 43. Status Registers**

CHANNEL <sup>(1)</sup>	REGISTER	FIELDS [ BIT(S) ]	VALUES
All	STATUS, addr 0x18	12 fields are available that contain various status bits [ 15:0 ]	Refer to Register Maps section for a description of the individual status bits.
All	ERROR_CONFIG, addr 0x19	12 fields are available that are used to configure error reporting [ 15:0 ]	Refer to Register Maps section for a description of the individual error configuration bits.

(1) Channels 2 and 3 are available for LDC1314 only.

See the STATUS ([Table 21](#)) and ERROR\_CONFIG ([Table 22](#)) register descriptions in the Register Map section. These registers can be configured to trigger an interrupt on the INTB pin for certain events. The following conditions must be met:

1. The error or status register must be unmasked by enabling the appropriate register bit in the ERROR\_CONFIG register.
2. The INTB function must be enabled by setting CONFIG.INTB\_DIS to 0.

When a bit field in the STATUS register is set, the entire STATUS register content is held until read or until the DATAx register is read. Reading also de-asserts INTB. After first starting conversions in active mode, the first read of STATUS should be performed after assertion of INTB.

Interrupts are cleared by one of the following events:

1. Entering Sleep Mode
2. Power-on reset (POR)
3. Device enters Shutdown Mode (SD is asserted)
4. S/W reset
5. I2C read of the STATUS register: Reading the STATUS register will clear any error status bit set in STATUS along with the ERR\_CHAN field and de-assert INTB

Setting register CONFIG.INTB\_DIS to b1 disables the INTB function and holds the INTB pin high.

The TI Application Note [LDC1312, LDC1314, LDC1612, LDC1614 Sensor Status Monitoring](#) provides detailed information on sensor status reporting.

### 8.1.9 Multi-Channel Data Readback

When in multi-channel mode, the LDC1312/LDC1314 alternates conversions on all selected channels. After each channel conversion completes, the conversion results for that channel overwrites the previous conversion results with the new data.

When the device completes a conversion on the last channel in the selected group, the device will pull INTB low if DRDY2INT is set to 1. At this time, the conversion results should be retrieved via the I2C bus.

If the device is put into Sleep mode or Shutdown mode, all DATAx registers are cleared of conversion data.

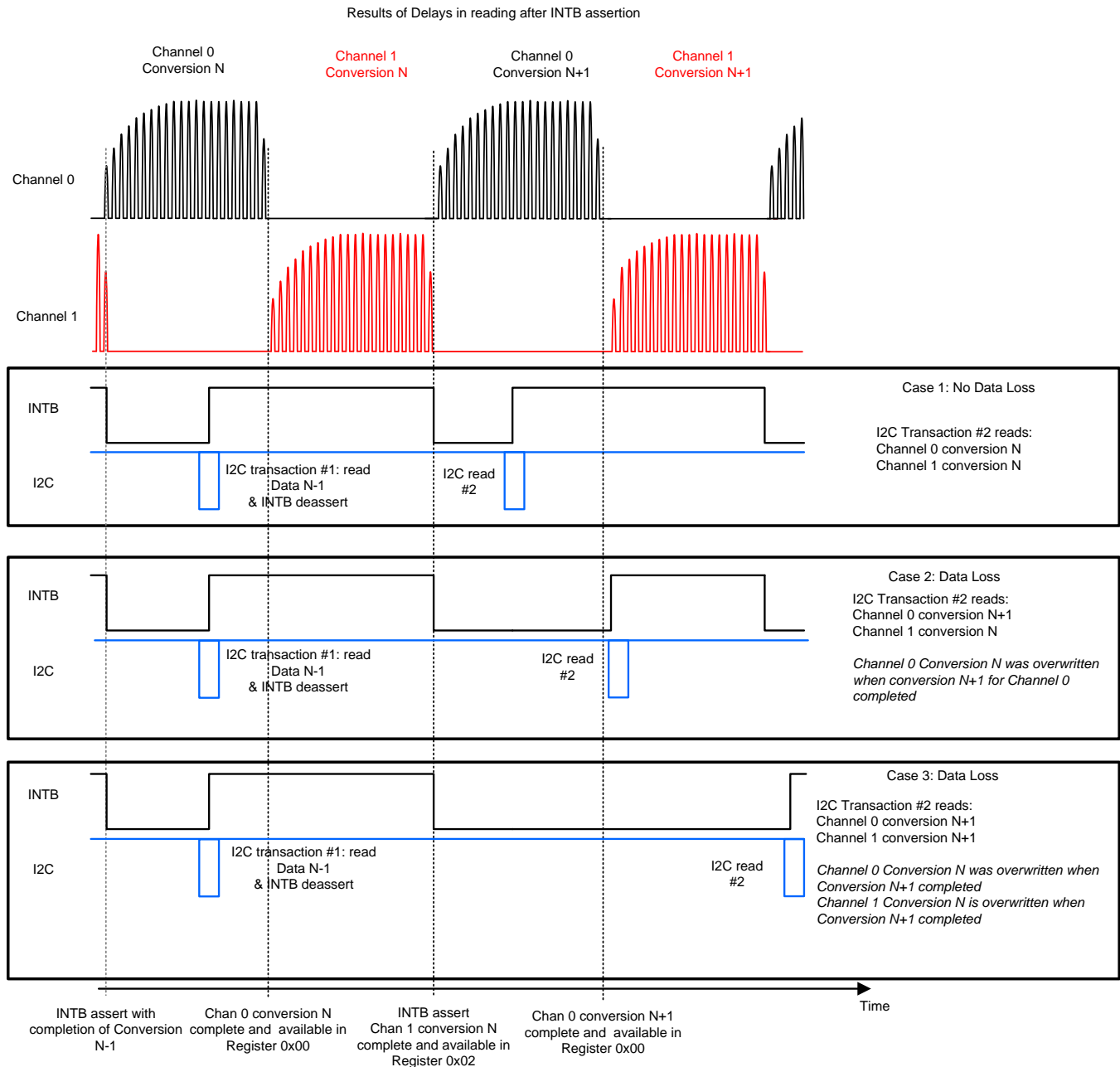

**Figure 55. Data Readback Timing**

The STATUS register (Address 0x18) flags UNREADCONVx monitor the accesses to the DATAx registers.

When the DATAx register is read, the corresponding UNREADCONVx flag is cleared.

As shown in [Figure 55](#), if the I2C data readback is delayed, then it is possible to lose older, unread conversion results. Monitoring the UNREADCONVx flags are useful to assess whether data loss is occurring.

A delayed read of previous conversion results can produce the condition in which reading the STATUS register immediately after INTB asserts shows that Channel 0 has no unread data (where the UNREADCONV0 flag is 0), but other channels do have unread data indicated by the corresponding UNREADCONVx flags.

## 8.2 Typical Application

### 8.2.1 System Sensing Functionality

Inductive sensing provides a wide range of system advantages that no other technology can provide - contactless measurement, resistance to dirt/dust/water, immunity to external magnets, remote sensor positioning, inexpensive and robust sensors, and high resolution measurement of relative movement.

The LDC1312/LDC1314 can be used to sense a wide range of applications for measuring a variety of target movement:

- Angular Measurement: refer to [1-Degree Dial Reference Design](#) for an example implementation.
- Linear Position Sensing: details on sensor and target construction are available in [LDC1612/LDC1614 Linear Position Sensing Application Note](#). For absolute positioning needs, it is recommended to use a differential 2 channel construction.
- Encoder Knob: refer to [Inductive Sensing 32-Position Encoder Knob Reference Design](#) for an example system implementation.
- Inductive buttons using snap-domes: refer to [16-Button Inductive Keypad Reference Design](#) for an example system implementation.

### 8.2.2 Example Application

Example of a multi-channel implementation using the LDC1312. This example is representative of an axial displacement application, in which the target movement is perpendicular to the plane of the coil. The second channel can be used to sense proximity of a second target, or it can be used for environmental compensation by connecting a reference coil.

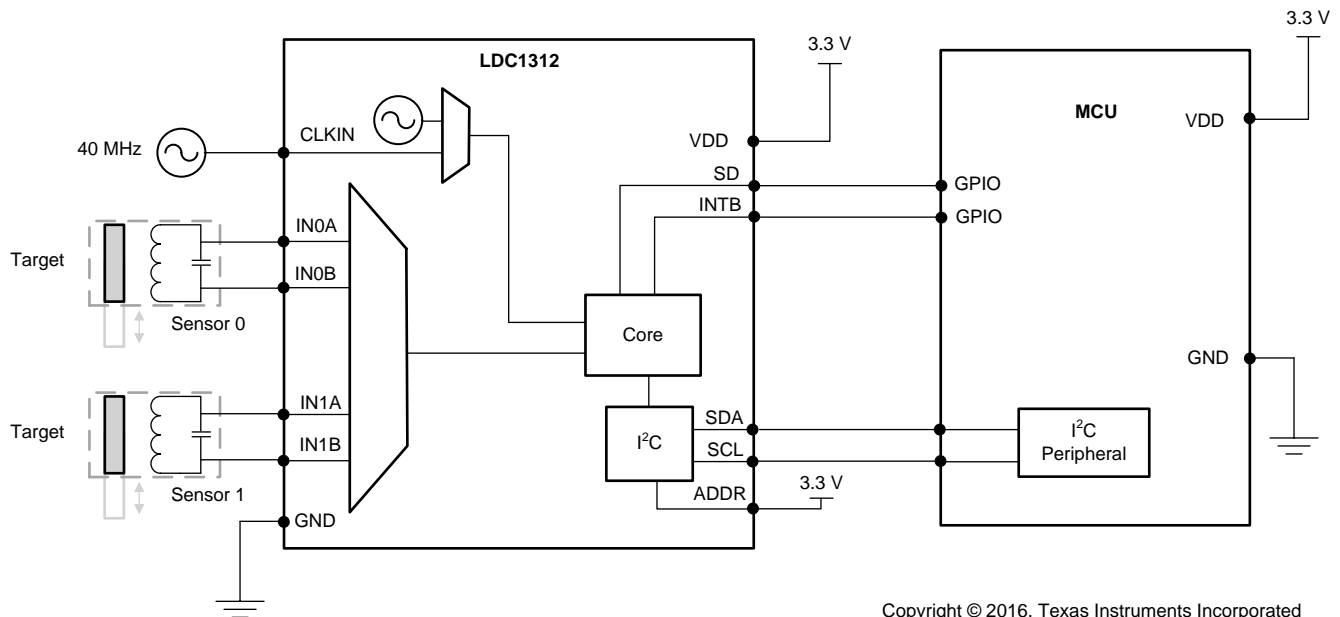

**Figure 56. Example Multi-Channel Application - LDC1312**

### 8.2.3 Design Requirements

Design example in which Sensor 0 is used for proximity measurement and Sensor 1 is used for temperature compensation. WEBENCH coil designer tool used to create sensor. System measurement requirements:

- Target distance = 1.0 mm
- Distance resolution = 0.2  $\mu\text{m}$
- Target diameter = 10 mm
- Target material = stainless steel (SS416)
- Number of PCB layers for the coil = 2
- The application requires 1 kSPS ( $T_{\text{SAMPLE}} = 1.00 \text{ ms}$ )

## Typical Application (continued)

### 8.2.4 Detailed Design Procedure

The target distance, resolution and diameter are used as inputs to WEBENCH to design the sensor coil. The resulting coil design is a 2 layer coil, with an area of 2.5 cm<sup>2</sup>, diameter of 17.7 mm, and 39 turns. The values for R<sub>p</sub>, L and C are: R<sub>p</sub> = 6.6 kΩ, L = 43.9 μH, C = 100 pF.

Using the L and C to determine  $f_{\text{SENSOR}} = 1/2\pi\sqrt{LC} = 1/2\pi\sqrt{(43.9 \times 10^{-6} * 100 \times 10^{-12})} = 2.4 \text{ MHz}$

With a system reference clock of 40 MHz applied to the CLKIN pin allows flexibility for setting the internal clock frequencies. The sensor coil is connected to channel 0 (IN0A and IN0B pins).

After powering on the LDC, it will be in Sleep Mode. Program the registers as follows (this example sets registers for channel 0 only; channel 1 registers can use equivalent configuration):

1. Set the dividers for Channel 0.
  - a. Because the sensor frequency is less than 8.75 MHz, the sensor divider can be set to 1, which means setting field FIN\_DIVIDER0 to 0x1. By default,  $f_{\text{IN0}} = f_{\text{SENSOR}} = 2.4 \text{ MHz}$ .
  - b. The design constraint for  $f_{\text{REF0}}$  is  $> 4 \times f_{\text{SENSOR}}$ . The 40 MHz reference frequency satisfies this constraint, so the reference divider can be set to 1. This is done by setting the FREF\_DIVIDER0 field to 0x01.
  - c. The combined value for Chan. 0 divider register (0x14) is 0x1002.
2. Program the settling time for Channel 0. The calculated Q of the coil is 10 (see [Multi-Channel and Single Channel Operation](#)).
  - a.  $\text{SETTLECOUNT0} \geq Q \times f_{\text{REF0}} / (16 \times f_{\text{SENSOR0}}) \rightarrow 5.2$ , rounded up to 6. To provide margin to account for system tolerances, a higher value of 10 is chosen.
  - b. Register 0x10 should be programmed to a minimum of 10.
  - c. The settle time is:  $(10 \times 16)/20,000,000 = 8 \mu\text{s}$
  - d. The value for SETTLECOUNT0 register (0x10) is 0x000A.
3. The channel switching delay is ~1 μs for  $f_{\text{REF}} = 20 \text{ MHz}$  (see [Multi-Channel and Single Channel Operation](#))
4. Set the conversion time by the programming the reference count for Channel 0. The budget for the conversion time is:  $T_{\text{SAMPLE}} - \text{settling time} - \text{channel switching delay} = 1000 - 8 - 1 = 991 \mu\text{s}$ 
  - a. To determine the conversion time register value, use the following equation and solve for RCOUNT0:  
Conversion Time ( $t_{\text{CO}}$ ) =  $(\text{RCOUNT0} \times 16)/f_{\text{REF0}}$ .
  - b. This results in RCOUNT0 having a value of 1238 decimal (rounded down)
  - c. Set the RCOUNT0 register (0x08) to 0x04D6.
5. Use the default values for the ERROR\_CONFIG register (address 0x19). By default, no interrupts are enabled
6. Sensor drive current: to set the IDRIVE0 field value, read the value from [Figure 52](#) using R<sub>p</sub> = 6.6 kΩ. In this case IDRIVE0 value should be set to 18 (decimal). The INIT\_DRIVE0 current field should be set to 0x00. The combined value for the DRIVE\_CURRENT0 register (addr 0x1E) is 0x9000.
7. Program the MUX\_CONFIG register
  - a. Set the AUTOSCAN\_EN to b1 bit to enable sequential mode
  - b. Set RR\_SEQUENCE to b00 to enable data conversion on two channels (channel 0, channel 1)
  - c. Set DEGLITCH to b100 to set the input deglitch filter bandwidth to 3.3MHz, the lowest setting that exceeds the oscillation tank frequency.
  - d. The combined value for the MUX\_CONFIG register (address 0x1B) is 0x820C
8. Finally, program the CONFIG register as follows:
  - a. Set the ACTIVE\_CHAN field to b00 to select channel 0.
  - b. Set SLEEP\_MODE\_EN field to b0 to enable conversion.
  - c. Set RP\_OVERRIDE\_EN to b1 to disable auto-calibration.
  - d. Set SENSOR\_ACTIVATE\_SEL = b0, for full current drive during sensor activation
  - e. Set the AUTO\_AMP\_DIS field to b1 to disable auto-amplitude correction
  - f. Set the REF\_CLK\_SRC field to b1 to use the external clock source.
  - g. Set the other fields to their default values.

## Typical Application (continued)

h. The combined value for the CONFIG register (address 0x1A) is 0x1601.

We then read the conversion results for channel 0 and channel 1 every 1.00 ms from register addresses 0x00 and 0x02.

### 8.2.5 Recommended Initial Register Configuration Values

Based on the example configuration in section [Detailed Design Procedure](#), the following register write sequence is recommended:

**Table 44. Recommended Initial Register Configuration Values (Single-Channel Operation)**

ADDRESS	VALUE	REGISTER NAME	COMMENTS
0x08	0x04D6	RCOUNT0	Reference count calculated from timing requirements (1 kSPS) and resolution requirements
0x10	0x000A	SETTLECOUNT0	Minimum settling time for chosen sensor
0x14	0x1002	CLOCK_DIVIDERS0	FIN_DIVIDER0 = 1, FREF_DIVIDER0 = 2
0x19	0x0000	ERROR_CONFIG	Can be changed from default to report status and error conditions
0x1B	0x020C	MUX_CONFIG	Enable Channel 0 in continuous mode, set Input deglitch bandwidth to 3.3MHz
0x1E	0x9000	DRIVE_CURRENT0	Sets sensor drive current on channel 0
0x1A	0x1601	CONFIG	Select active channel = ch 0, disable auto-amplitude correction and auto-calibration, enable full current drive during sensor activation, select external clock source, wake up device to start conversion. This register write must occur last because device configuration is not permitted while the LDC is in active mode.

**Table 45. Recommended Initial Register Configuration Values (Multi-Channel Operation)**

ADDRESS	VALUE	REGISTER NAME	COMMENTS
0x08	0x04D6	RCOUNT0	Reference count calculated from timing requirements (1 kSPS) and resolution requirements
0x09	0x04D6	RCOUNT1	Reference count calculated from timing requirements (1 kSPS) and resolution requirements
0x10	0x000A	SETTLECOUNT0	Minimum settling time for chosen sensor
0x11	0x000A	SETTLECOUNT1	Minimum settling time for chosen sensor
0x14	0x1002	CLOCK_DIVIDERS0	FIN_DIVIDER0 = 1, FREF_DIVIDER0 = 2
0x15	0x1002	CLOCK_DIVIDERS_1	FIN_DIVIDER1 = 1, FREF_DIVIDER1 = 2
0x19	0x0000	ERROR_CONFIG	Can be changed from default to report status and error conditions
0x1B	0x820C	MUX_CONFIG	Enable Ch 0 and Ch 1 (sequential mode), set Input deglitch bandwidth to 3.3MHz
0x1E	0x9000	DRIVE_CURRENT0	Sets sensor drive current on ch 0
0x1F	0x9000	DRIVE_CURRENT1	Sets sensor drive current on ch 1
0x1A	0x1601	CONFIG	Disable auto-amplitude correction and auto-calibration, enable full current drive during sensor activation, select external clock source, wake up device to start conversion. This register write must occur last because device configuration is not permitted while the LDC is in active mode.

## 8.2.6 Application Curves

### Common Test Conditions (unless specified otherwise):

- Sensor inductor: 2 layer, 32 turns/layer, 14mm diameter, PCB inductor with  $L=19.4 \mu\text{H}$ ,  $R_p=5.7 \text{ k}\Omega$  at 2 MHz
- Sensor capacitor: 330 pF 1% COG/NP0
- Target: Aluminum, 1.5 mm thickness
- Channel = Channel 0 (continuous mode)
- $f_{\text{CLKIN}} = 40 \text{ MHz}$ ,  $\text{FIN\_DIVIDERx} = 0x01$ ,  $\text{FREF\_DIVIDERx} = 0x001$
- $\text{RCOUNT0} = 0xFFFF$ ,  $\text{SETTLECOUNT0} = 0x0100$
- $\text{RP\_OVERRIDE} = 1$ ,  $\text{AUTO\_AMP\_DIS} = 1$ ,  $\text{DRIVE\_CURRENT0} = 0x9800$

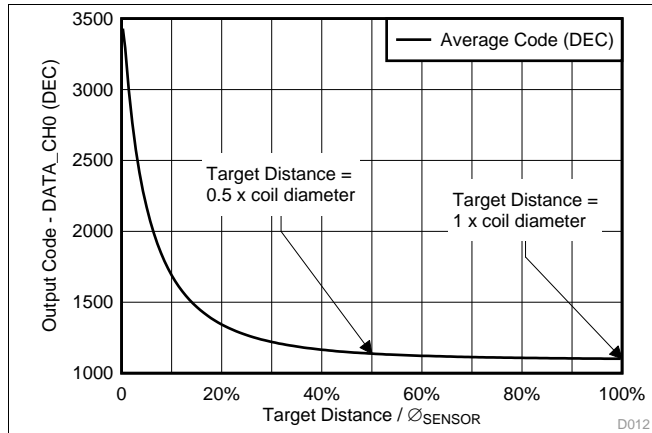

**Figure 57. Typical Output Code vs. Target Distance (0 to 14mm)**

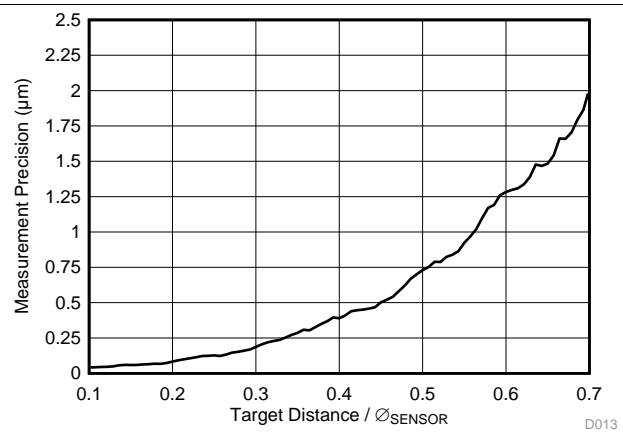

**Figure 58. Measurement Precision in Distance vs. Target Distance (0 to 10mm)**

### 8.2.7 Inductor Self-Resonant Frequency

Every inductor has a distributed parasitic capacitance, which is dependent on construction and geometry. At the Self-Resonant Frequency (SRF), the reactance of the inductor cancels the reactance of the parasitic capacitance. Above the SRF, the inductor will electrically appear to be a capacitor. Because the parasitic capacitance is not well-controlled or stable, it is recommended that:  $f_{\text{SENSOR}} < 0.8 \times f_{\text{SR}}$ .

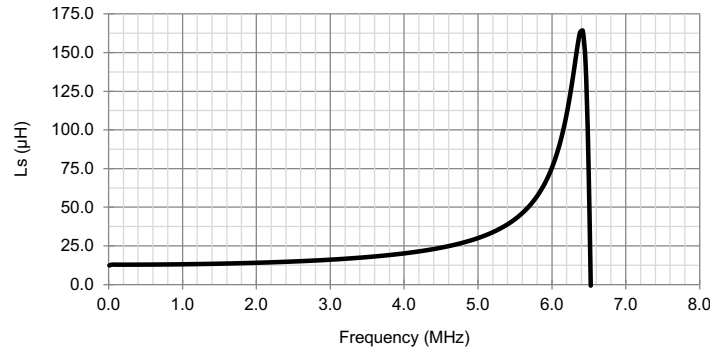

**Figure 59. Example Coil Inductance vs. Frequency**

In [Figure 59](#), the inductor has a SRF at 6.38 MHz; therefore the inductor should not be operated above  $0.8 \times 6.38$  MHz, or 5.1 MHz.

## 9 Power Supply Recommendations

- The LDC requires a voltage supply within 2.7 V and 3.6 V. A multilayer ceramic X7R bypass capacitor of 1  $\mu\text{F}$  between the VDD and GND pins is recommended. If the supply is located more than a few inches from the LDC, additional capacitance may be required in addition to the ceramic bypass capacitor. A ceramic capacitor with a value of 10  $\mu\text{F}$  is a typical choice.
- The optimum placement of bypass capacitors is closest to the VDD and GND terminals of the device. Care should be taken to minimize the loop area formed by the bypass capacitor connection, the VDD pin, and the GND pin of the IC. See [Figure 60](#) for a layout example.

## 10 Layout

### 10.1 Layout Guidelines

Avoid long traces between the sensor and the LDC - higher frequency sensors may need to be placed closer to the device to minimize noise. The INAx and INBx traces should be routed as differential pairs - run the traces in parallel and close together. Lower trace impedances (even well below 100  $\Omega$ ) are acceptable, as they reduce any parasitic inductance.

The sensor capacitor should be placed close to the inductor to minimize the sensor  $R_p$ .

Do not place filled planes underneath or between the sensor layers. If the sensor is placed in a plane, there should be a gap of at least 20% of a sensor diameter between the plane and the outermost coil of the sensor. There should not be any continuous ring of conductors encircling the sensor. This can be managed with a small cut in the conductor.

Refer to the TI Application Note [LDC Sensor Design](#) for more information on sensor design and optimization.

### 10.2 Layout Example

Figure 60 shows an example layout for the LDC1312, including a pair of sensor.

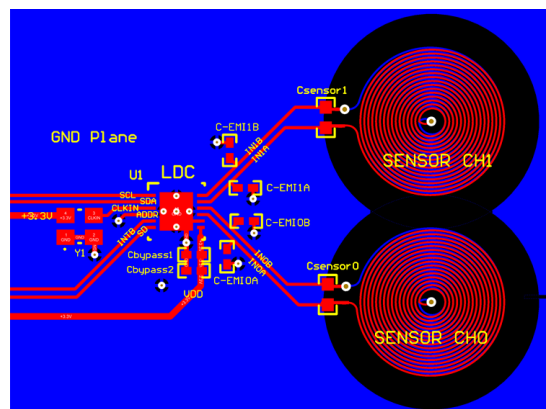

**Figure 60. Example PCB Layout**

## 11 器件和文档支持

### 11.1 器件支持

#### 11.1.1 开发支持

相关链接如下：

- 德州仪器 (TI) 的 WEBENCH 工具：<http://www.ti.com.cn/webench>

### 11.2 文档支持

#### 11.2.1 相关文档

相关文档如下：

- 《LDC1000 温度补偿》 SNAA212
- 《LDC 传感器设计》 SNOA930
- 《LDC1612/LDC1614 线性位置感应应用手册》 SNOA931
- 《优化 LDC1312 和 LDC1314 的 L 测量分辨率》 SNOA945
- 《针对电感感应的 LDC131x/161x 功率降低技术》 SNOA949
- 《优化 LDC161x 和 LDC1101 的 L 测量分辨率》 SNOA950
- 《电感感应触摸金属按钮设计指南》 SNOA951
- 《LDC 目标设计》 SNOA957
- 《LDC1312、LDC1314、LDC1612、LDC1614 传感器状态监控》 SNOA959
- 《16 按钮电感式触控不锈钢键盘参考设计》
- 32 位电感感应编码器旋钮参考设计
- 《16 按钮电感式键盘参考设计》
- 《1 度转盘参考设计》

### 11.3 相关链接

下表列出了快速访问链接。类别包括技术文档、支持和社区资源、工具和软件以及申请样片或购买产品的快速访问链接。

表 46. 相关链接

器件	产品文件夹	样片与购买	技术文档	工具和软件	支持和社区
LDC1312	<a href="#">请单击此处</a>	<a href="#">请单击此处</a>	<a href="#">请单击此处</a>	<a href="#">请单击此处</a>	<a href="#">请单击此处</a>
LDC1314	<a href="#">请单击此处</a>	<a href="#">请单击此处</a>	<a href="#">请单击此处</a>	<a href="#">请单击此处</a>	<a href="#">请单击此处</a>

### 11.4 接收文档更新通知

要接收文档更新通知，请导航至 TI.com.cn 上的器件产品文件夹。点击右上角的提醒我 (Alert me) 注册后，即可每周定期收到已更改的产品信息。有关更改的详细信息，请查看任何已修订文档中包含的修订历史记录。

### 11.5 社区资源

下列链接提供到 TI 社区资源的连接。链接的内容由各个分销商“按照原样”提供。这些内容并不构成 TI 技术规范，并且不一定反映 TI 的观点；请参阅 TI 的《使用条款》。

**TI E2E™ 在线社区** TI 的工程师对工程师 (E2E) 社区。此社区的创建目的在于促进工程师之间的协作。在 e2e.ti.com 中，您可以咨询问题、分享知识、拓展思路并与同行工程师一道帮助解决问题。

**设计支持** TI 参考设计支持 可帮助您快速查找有帮助的 E2E 论坛、设计支持工具以及技术支持的联系信息。

### 11.6 商标

E2E is a trademark of Texas Instruments.

WEBENCH is a registered trademark of Texas Instruments.

All other trademarks are the property of their respective owners.

## 11.7 静电放电警告



这些装置包含有限的内置 ESD 保护。存储或装卸时，应将导线一起截短或将装置放置于导电泡棉中，以防止 MOS 门极遭受静电损伤。

## 11.8 Glossary

[SLYZ022](#) — *TI Glossary*.

This glossary lists and explains terms, acronyms, and definitions.

## 12 机械、封装和可订购信息

以下页面包含机械、封装和可订购信息。这些信息是指定器件的最新可用数据。数据如有变更，恕不另行通知，也不会对此文档进行修订。如需获取此数据表的浏览器版本，请参阅左侧的导航栏。

**PACKAGING INFORMATION**

Orderable Device	Status (1)	Package Type	Package Drawing	Pins	Package Qty	Eco Plan (2)	Lead finish/ Ball material (6)	MSL Peak Temp (3)	Op Temp (°C)	Device Marking (4/5)	Samples
LDC1312DNTR	ACTIVE	WSON	DNT	12	4500	RoHS & Green	SN	Level-1-260C-UNLIM	-40 to 125	LDC1312	<a href="#">Samples</a>
LDC1312DNTT	ACTIVE	WSON	DNT	12	250	RoHS & Green	SN	Level-1-260C-UNLIM	-40 to 125	LDC1312	<a href="#">Samples</a>
LDC1314RGHR	ACTIVE	WQFN	RGH	16	4500	RoHS & Green	SN	Level-1-260C-UNLIM	-40 to 125	LDC1314	<a href="#">Samples</a>
LDC1314RGHT	ACTIVE	WQFN	RGH	16	250	RoHS & Green	SN	Level-1-260C-UNLIM	-40 to 125	LDC1314	<a href="#">Samples</a>

(1) The marketing status values are defined as follows:

**ACTIVE:** Product device recommended for new designs.

**LIFEBUY:** TI has announced that the device will be discontinued, and a lifetime-buy period is in effect.

**NRND:** Not recommended for new designs. Device is in production to support existing customers, but TI does not recommend using this part in a new design.

**PREVIEW:** Device has been announced but is not in production. Samples may or may not be available.

**OBSELETE:** TI has discontinued the production of the device.

(2) **RoHS:** TI defines "RoHS" to mean semiconductor products that are compliant with the current EU RoHS requirements for all 10 RoHS substances, including the requirement that RoHS substance do not exceed 0.1% by weight in homogeneous materials. Where designed to be soldered at high temperatures, "RoHS" products are suitable for use in specified lead-free processes. TI may reference these types of products as "Pb-Free".

**RoHS Exempt:** TI defines "RoHS Exempt" to mean products that contain lead but are compliant with EU RoHS pursuant to a specific EU RoHS exemption.

**Green:** TI defines "Green" to mean the content of Chlorine (Cl) and Bromine (Br) based flame retardants meet JS709B low halogen requirements of <=1000ppm threshold. Antimony trioxide based flame retardants must also meet the <=1000ppm threshold requirement.

(3) **MSL, Peak Temp.** - The Moisture Sensitivity Level rating according to the JEDEC industry standard classifications, and peak solder temperature.

(4) There may be additional marking, which relates to the logo, the lot trace code information, or the environmental category on the device.

(5) Multiple Device Markings will be inside parentheses. Only one Device Marking contained in parentheses and separated by a "-" will appear on a device. If a line is indented then it is a continuation of the previous line and the two combined represent the entire Device Marking for that device.

(6) **Lead finish/Ball material** - Orderable Devices may have multiple material finish options. Finish options are separated by a vertical ruled line. Lead finish/Ball material values may wrap to two lines if the finish value exceeds the maximum column width.

**Important Information and Disclaimer:**The information provided on this page represents TI's knowledge and belief as of the date that it is provided. TI bases its knowledge and belief on information provided by third parties, and makes no representation or warranty as to the accuracy of such information. Efforts are underway to better integrate information from third parties. TI has taken and

continues to take reasonable steps to provide representative and accurate information but may not have conducted destructive testing or chemical analysis on incoming materials and chemicals. TI and TI suppliers consider certain information to be proprietary, and thus CAS numbers and other limited information may not be available for release.

In no event shall TI's liability arising out of such information exceed the total purchase price of the TI part(s) at issue in this document sold by TI to Customer on an annual basis.

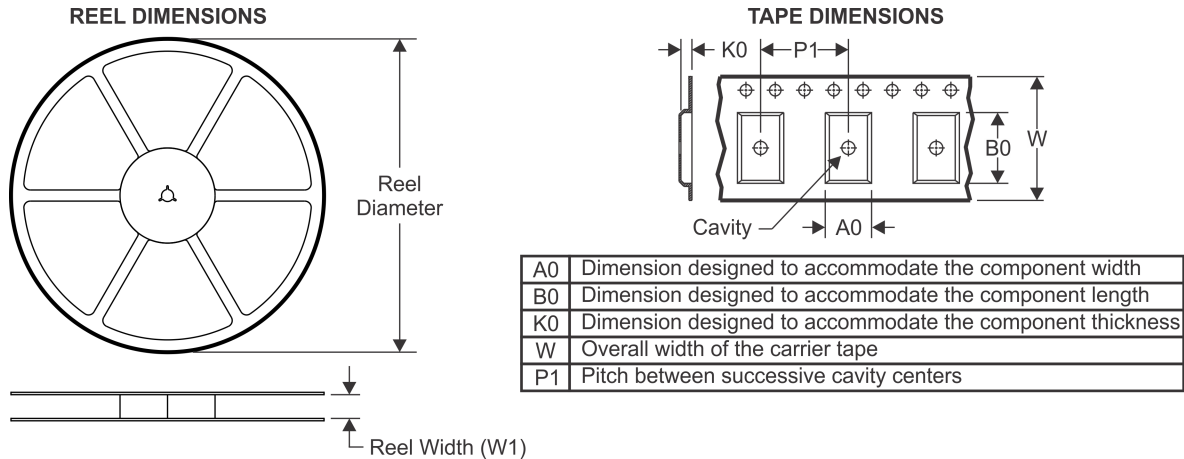
**TAPE AND REEL INFORMATION**

**QUADRANT ASSIGNMENTS FOR PIN 1 ORIENTATION IN TAPE**

\*All dimensions are nominal

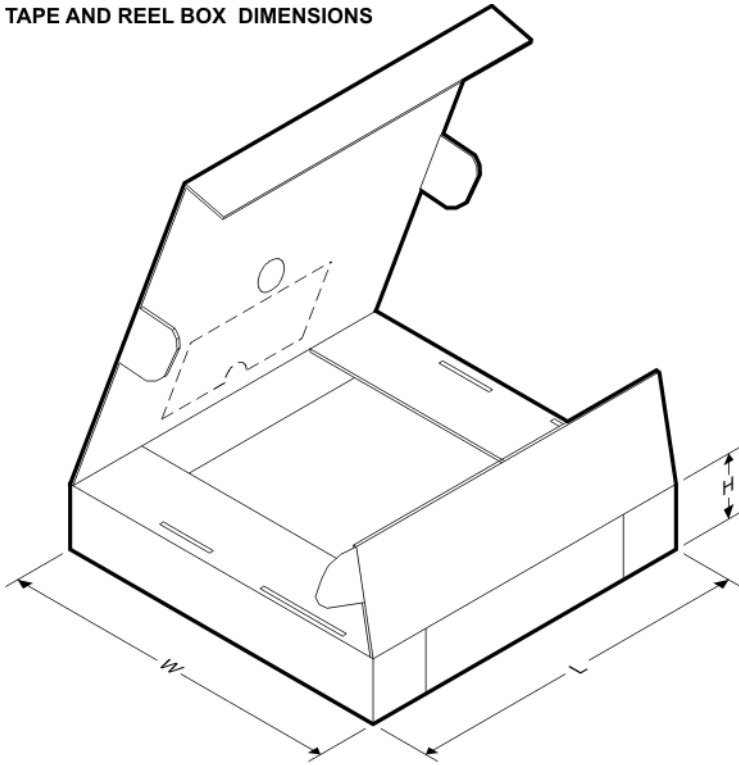
Device	Package Type	Package Drawing	Pins	SPQ	Reel Diameter (mm)	Reel Width W1 (mm)	A0 (mm)	B0 (mm)	K0 (mm)	P1 (mm)	W (mm)	Pin1 Quadrant
LDC1312DNTR	WSON	DNT	12	4500	330.0	12.4	4.3	4.3	1.3	8.0	12.0	Q1
LDC1312DNTR	WSON	DNT	12	250	178.0	12.4	4.3	4.3	1.3	8.0	12.0	Q1
LDC1314RGHR	WQFN	RGH	16	4500	330.0	12.4	4.3	4.3	1.3	8.0	12.0	Q1
LDC1314RGHT	WQFN	RGH	16	250	178.0	12.4	4.3	4.3	1.3	8.0	12.0	Q1

**TAPE AND REEL BOX DIMENSIONS**

\*All dimensions are nominal

Device	Package Type	Package Drawing	Pins	SPQ	Length (mm)	Width (mm)	Height (mm)
LDC1312DNTR	WSON	DNT	12	4500	367.0	367.0	35.0
LDC1312DNTR	WSON	DNT	12	250	210.0	185.0	35.0
LDC1314RGHR	WQFN	RGH	16	4500	367.0	367.0	35.0
LDC1314RGHT	WQFN	RGH	16	250	210.0	185.0	35.0



# EXAMPLE BOARD LAYOUT

DNT0012B

WSON - 0.8 mm max height

PLASTIC SMALL OUTLINE - NO LEAD

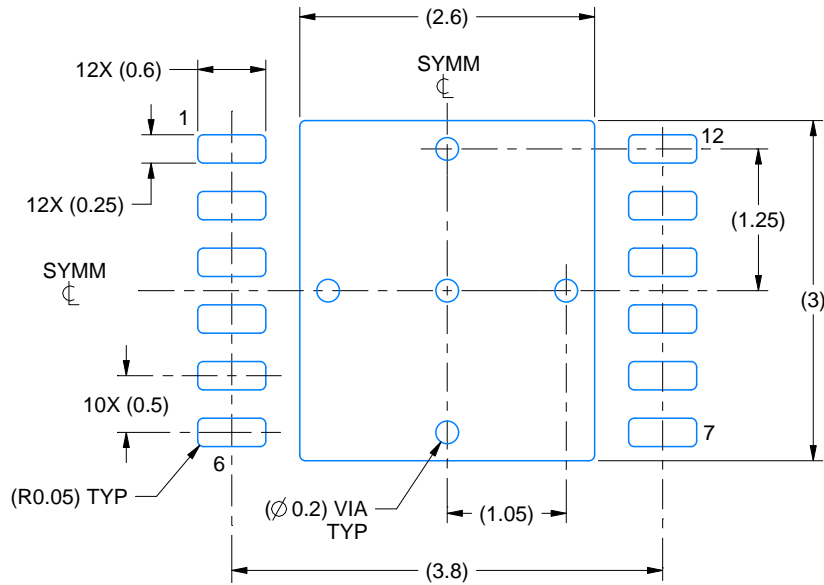

LAND PATTERN EXAMPLE  
EXPOSED METAL SHOWN  
SCALE:15X

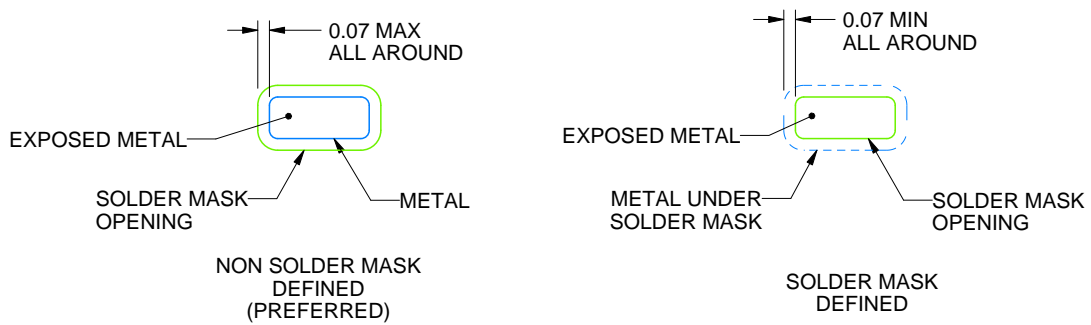

SOLDER MASK DETAILS

4214928/C 10/2021

NOTES: (continued)

4. This package is designed to be soldered to a thermal pad on the board. For more information, see Texas Instruments literature number SLUA271 ([www.ti.com/lit/slua271](http://www.ti.com/lit/slua271)).

# EXAMPLE STENCIL DESIGN

DNT0012B

WSON - 0.8 mm max height

PLASTIC SMALL OUTLINE - NO LEAD

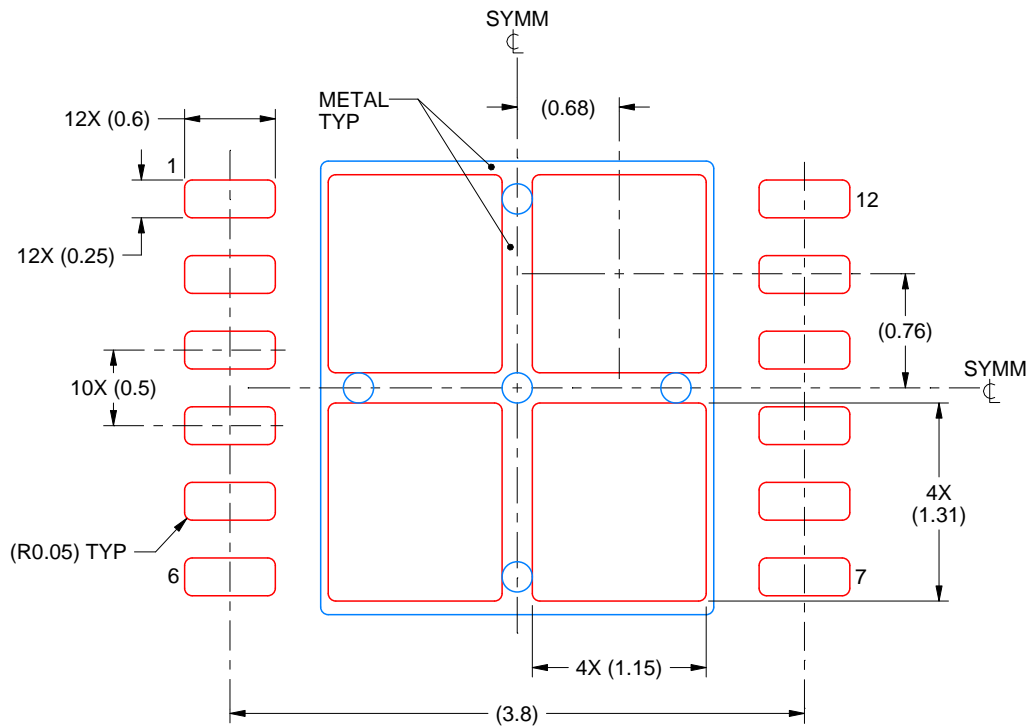

SOLDER PASTE EXAMPLE  
BASED ON 0.125 mm THICK STENCIL

EXPOSED PAD  
77% PRINTED SOLDER COVERAGE BY AREA  
SCALE:20X

4214928/C 10/2021

NOTES: (continued)

5. Laser cutting apertures with trapezoidal walls and rounded corners may offer better paste release. IPC-7525 may have alternate design recommendations.

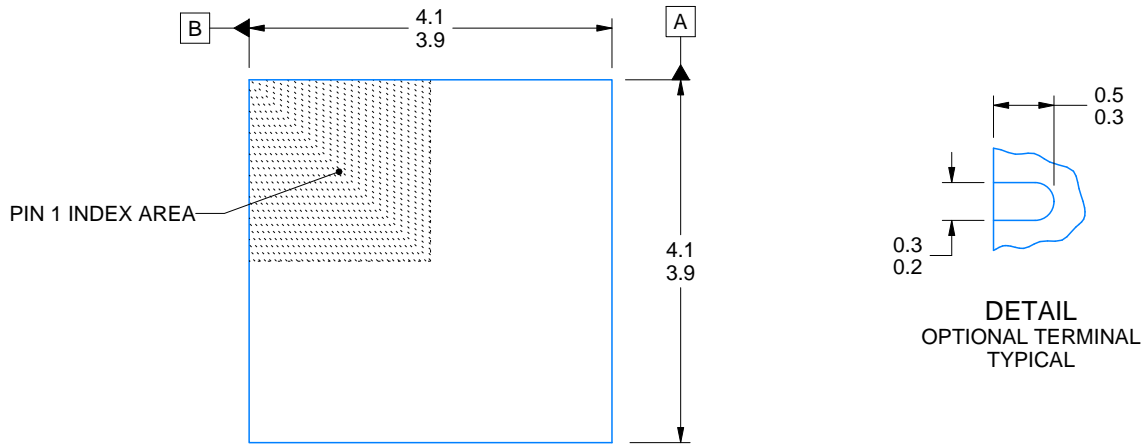
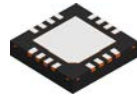

DIM A	
OPT 1	OPT 1
(0.1)	(0.2)

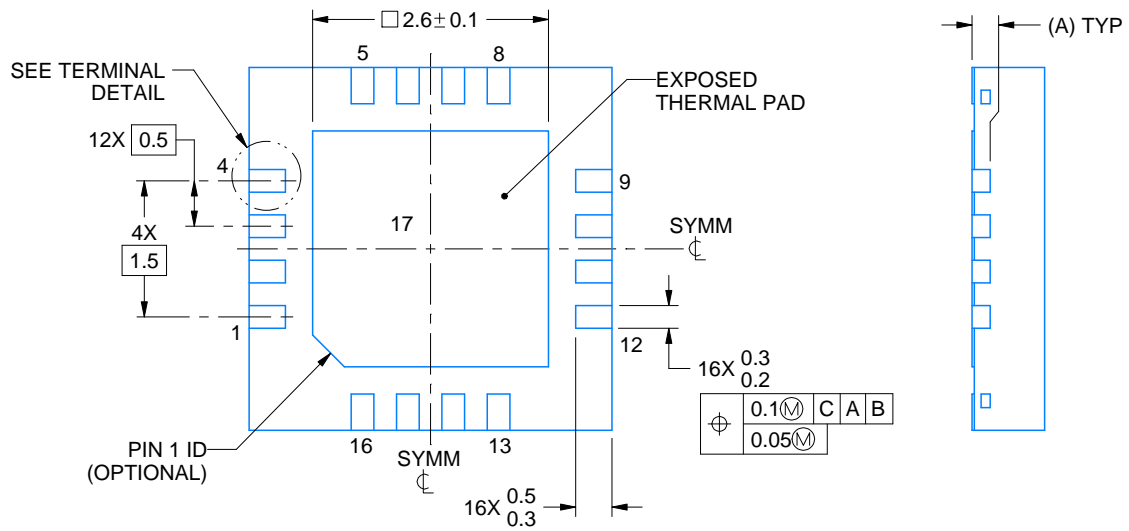
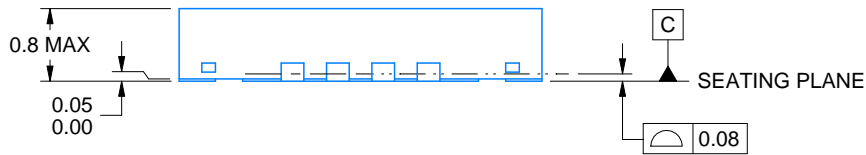

4214978/B 01/2017

NOTES:

1. All linear dimensions are in millimeters. Any dimensions in parenthesis are for reference only. Dimensioning and tolerancing per ASME Y14.5M.
2. This drawing is subject to change without notice.
3. The package thermal pad must be soldered to the printed circuit board for optimal thermal and mechanical performance.

# EXAMPLE BOARD LAYOUT

RGH0016A

WQFN - 0.8 mm max height

PLASTIC QUAD FLATPACK - NO LEAD

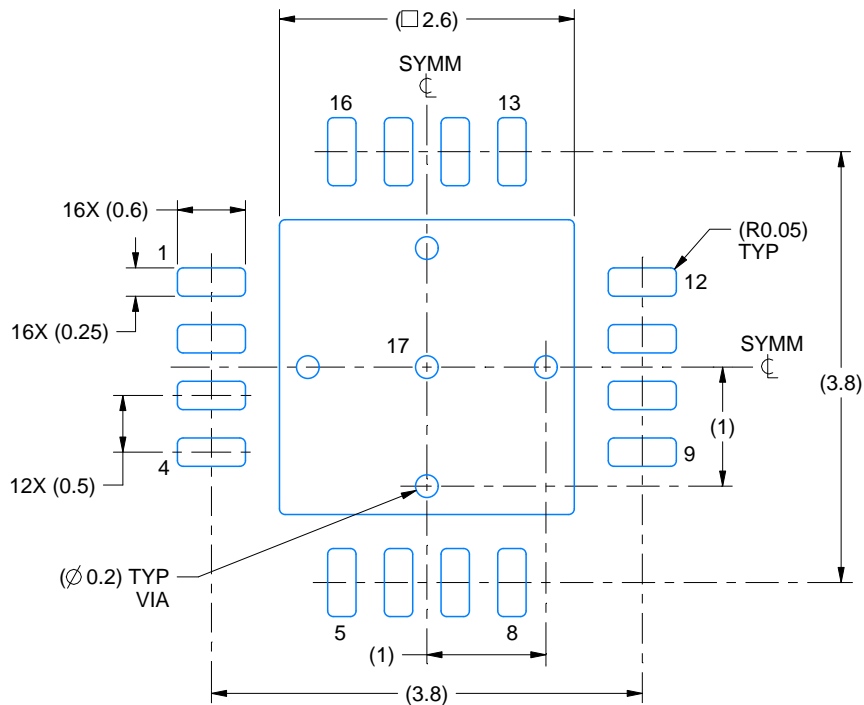

LAND PATTERN EXAMPLE  
EXPOSED METAL SHOWN  
SCALE:15X

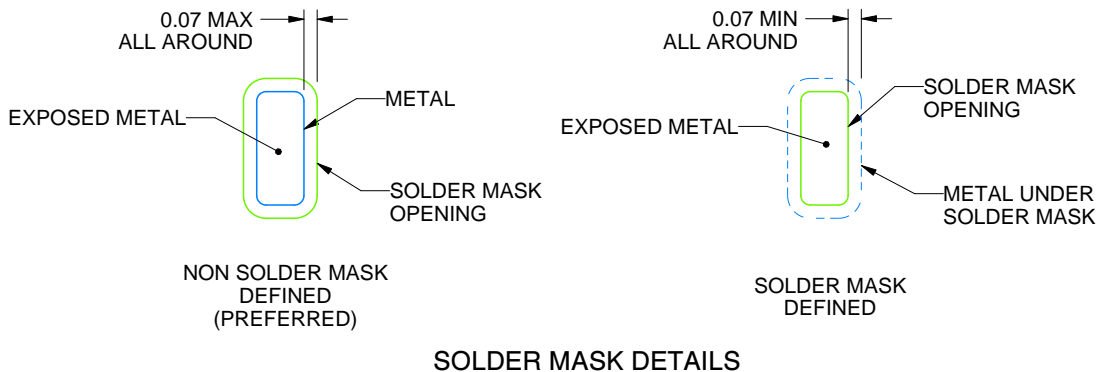

SOLDER MASK DETAILS

4214978/B 01/2017

NOTES: (continued)

4. This package is designed to be soldered to a thermal pad on the board. For more information, see Texas Instruments literature number SLUA271 ([www.ti.com/lit/slua271](http://www.ti.com/lit/slua271)).
5. Vias are optional depending on application, refer to device data sheet. If any vias are implemented, refer to their locations shown on this view. It is recommended that vias under paste be filled, plugged or tented.



## 重要声明和免责声明

TI“按原样”提供技术和可靠性数据（包括数据表）、设计资源（包括参考设计）、应用或其他设计建议、网络工具、安全信息和其他资源，不保证没有瑕疵且不做任何明示或暗示的担保，包括但不限于对适销性、某特定用途方面的适用性或不侵犯任何第三方知识产权的暗示担保。

这些资源可供使用 TI 产品进行设计的熟练开发人员使用。您将自行承担以下全部责任：(1) 针对您的应用选择合适的 TI 产品，(2) 设计、验证并测试您的应用，(3) 确保您的应用满足相应标准以及任何其他功能安全、信息安全、监管或其他要求。

这些资源如有变更，恕不另行通知。TI 授权您仅可将这些资源用于研发本资源所述的 TI 产品的应用。严禁对这些资源进行其他复制或展示。您无权使用任何其他 TI 知识产权或任何第三方知识产权。您应全额赔偿因在这些资源的使用中对 TI 及其代表造成的任何索赔、损害、成本、损失和债务，TI 对此概不负责。

TI 提供的产品受 [TI 的销售条款](#) 或 [ti.com](#) 上其他适用条款/TI 产品随附的其他适用条款的约束。TI 提供这些资源并不会扩展或以其他方式更改 TI 针对 TI 产品发布的适用的担保或担保免责声明。

TI 反对并拒绝您可能提出的任何其他或不同的条款。

邮寄地址：Texas Instruments, Post Office Box 655303, Dallas, Texas 75265

Copyright © 2021，德州仪器 (TI) 公司