

## FEATURES

- **Controlled Baseline**
  - One Assembly Site
  - One Test Site
  - One Fabrication Site
- **Extended Temperature Performance of  $-55^{\circ}\text{C}$  to  $125^{\circ}\text{C}$**
- **Enhanced Diminishing Manufacturing Sources (DMS) Support**
- **Enhanced Product-Change Notification**
- **Qualification Pedigree <sup>(1)</sup>**
- **3-Pin SOT-23 Package**
- **Supply Current of  $9\ \mu\text{A}$  (Typical)**
- **Precision Supply Voltage Monitor**  
**2.5 V, 3 V, 3.3 V, 5 V**
- **Power-On Reset Generator With Fixed Delay Time of 200 ms**
- **Pin-for-Pin Compatible With MAX 809**

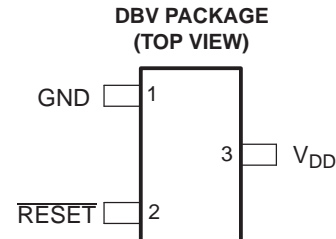

(1) Component qualification in accordance with JEDEC and industry standards to ensure reliable operation over an extended temperature range. This includes, but is not limited to, Highly Accelerated Stress Test (HAST) or biased 85/85, temperature cycle, autoclave or unbiased HAST, electromigration, bond intermetallic life, and mold compound life. Such qualification testing should not be viewed as justifying use of this component beyond specified performance and environmental limits.

## DESCRIPTION

The TPS3809 family of supervisory circuits provides circuit initialization and timing supervision, primarily for DSPs and processor-based systems.

During power-on,  $\overline{\text{RESET}}$  is asserted when the supply voltage  $V_{\text{DD}}$  becomes higher than 1.1 V. Thereafter, the supervisory circuit monitors  $V_{\text{DD}}$  and keeps  $\overline{\text{RESET}}$  active as long as  $V_{\text{DD}}$  remains below the threshold voltage  $V_{\text{IT}}$ . An internal timer delays the return of the output to the inactive state (high) to ensure proper system reset. The delay time,  $t_{\text{d(typ)}} = 200\ \text{ms}$ , starts after  $V_{\text{DD}}$  has risen above the  $V_{\text{IT}}$ . When the supply voltage drops below the  $V_{\text{IT}}$ , the output becomes active (low) again. No external components are required. All the devices of this family have a fixed-sense  $V_{\text{IT}}$  set by an internal voltage divider.

The product spectrum is designed for supply voltages of 2.5 V, 3 V, 3.3 V, and 5 V. The circuits are available in a 3-pin SOT-23 package. The TPS3809 devices are characterized for operation over a temperature range of  $-55^{\circ}\text{C}$  to  $125^{\circ}\text{C}$ .



Please be aware that an important notice concerning availability, standard warranty, and use in critical applications of Texas Instruments semiconductor products and disclaimers thereto appears at the end of this data sheet.

TYPICAL APPLICATIONS

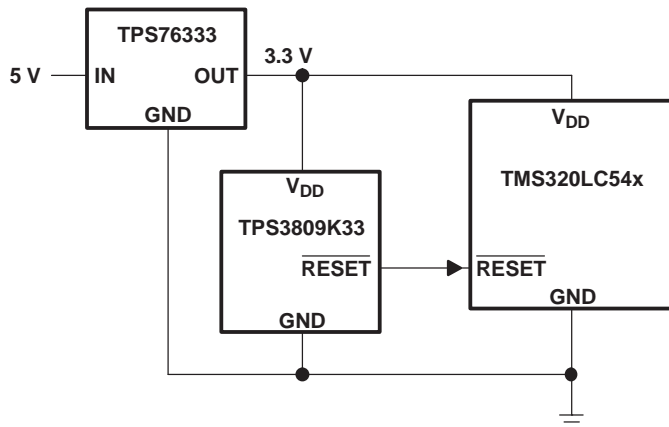

- Applications Using DSPs, Microcontrollers, or Microprocessors
- Wireless Communication Systems
- Portable/Battery-Powered Equipment
- Programmable Controls
- Intelligent Instruments
- Industrial Equipment
- Notebook/Desktop Computers
- Automotive Systems

AVAILABLE OPTIONS

T <sub>A</sub>	DEVICE NAME	THRESHOLD VOLTAGE	MARKING
-55°C to 125°C	TPS3809L30MDBVREP <sup>(1)</sup>	2.64 V	PLYM
	TPS3809K33MDBVREP <sup>(1)</sup>	2.93 V	PLZM
	TPS3809I50MDBVREP <sup>(1)</sup>	4.55 V	PMAM

(1) The DBVR passive indicates tape and reel of 3000 parts.

FUNCTION/TRUTH TABLE

V <sub>DD</sub> > V <sub>IT</sub>	RESET
0	L
1	H

ORDERING INFORMATION

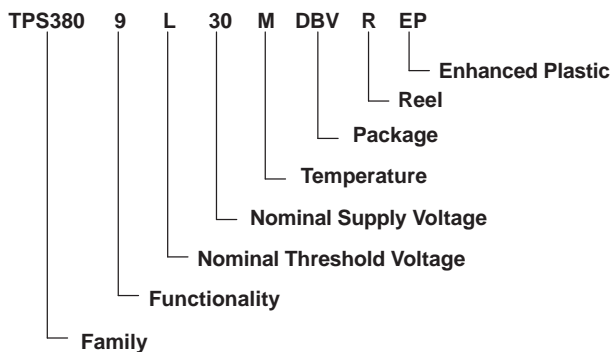

**FUNCTIONAL BLOCK DIAGRAM**

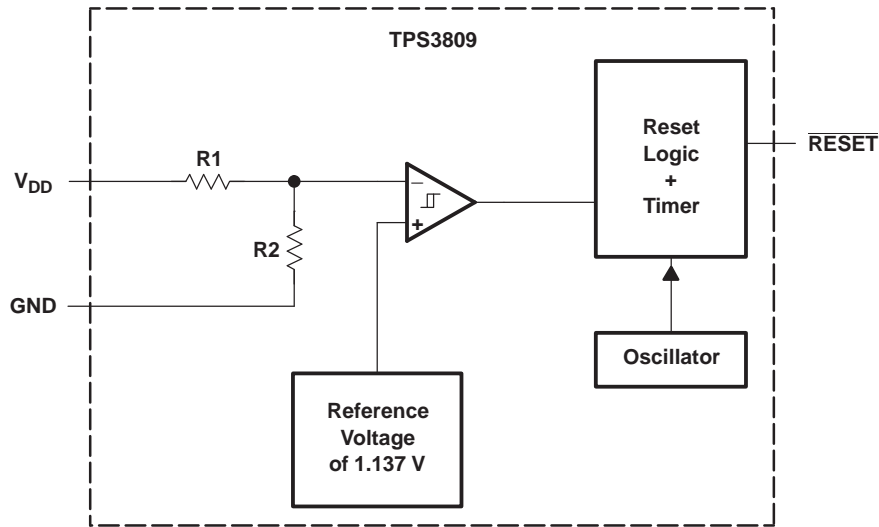

**TIMING DIAGRAM**

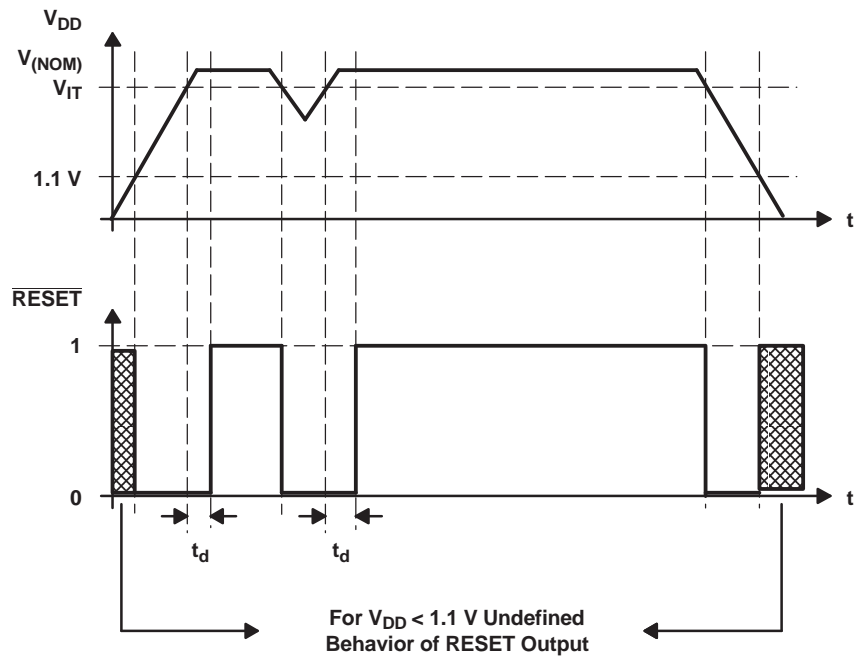

### Absolute Maximum Ratings<sup>(1)</sup>

over operating free-air temperature range (unless otherwise noted)

		MIN	MAX	UNIT
Supply voltage <sup>(2)</sup>	$V_{DD}$		7	V
	All other pins	-0.3	7	
$I_{OL}$	Maximum low output current		5	mA
$I_{OH}$	Maximum high output current		-5	mA
$I_{IK}$	Input clamp current	$V_I < 0$ or $V_I > V_{DD}$	$\pm 20$	mA
$I_{OK}$	Output clamp current	$V_O < 0$ or $V_O > V_{DD}$	$\pm 20$	mA
Continuous total power dissipation		See Dissipation Rating Table		
$T_A$	Operating free-air temperature range	-55	125	°C
$T_{stg}$	Storage temperature range	-65	150	°C
Soldering temperature			260	°C

- (1) Stresses beyond those listed under "absolute maximum ratings" may cause permanent damage to the device. These are stress ratings only, and functional operation of the device at these or any other conditions beyond those indicated under "recommended operating conditions" is not implied. Exposure to absolute-maximum-rated conditions for extended periods may affect device reliability.
- (2) All voltage values are with respect to GND. For reliable operation the device should not be operated at 7 V for more than  $t = 1000h$  continuously.

### Dissipation Ratings

PACKAGE	$T_A < 25^\circ\text{C}$ POWER RATING	DERATING FACTOR ABOVE $T_A = 25^\circ\text{C}$	$T_A = 70^\circ\text{C}$ POWER RATING	$T_A = 85^\circ\text{C}$ POWER RATING
DBV	437 mW	3.5 mW/°C	280 mW	227 mW

### Recommended Operating Conditions

		MIN	MAX	UNIT
$V_{DD}$	Supply voltage	2	6	V
$T_A$	Operating free-air temperature	-55	125	°C

## Electrical Characteristics

over recommended operating free-air temperature range (unless otherwise noted)

PARAMETER		TEST CONDITIONS	MIN	TYP	MAX	UNIT
V <sub>OH</sub>	High-level output voltage	V <sub>DD</sub> = 2.5 V to 6 V, I <sub>OH</sub> = -500 μA	V <sub>DD</sub> - 0.2			V
		V <sub>DD</sub> = 3.3 V, I <sub>OH</sub> = -2 mA	V <sub>DD</sub> - 0.4			
		V <sub>DD</sub> = 6 V, I <sub>OH</sub> = -4 mA	V <sub>DD</sub> - 0.4			
		V <sub>DD</sub> = 6 V, I <sub>OH</sub> = -4 mA, T <sub>A</sub> = 125°C	V <sub>DD</sub> - 0.5			
V <sub>OL</sub>	Low-level output voltage	V <sub>DD</sub> = 2 V to 6 V, I <sub>OL</sub> = 500 μA	0.2			V
		V <sub>DD</sub> = 3.3 V, I <sub>OL</sub> = 2 mA	0.4			
		V <sub>DD</sub> = 6 V, I <sub>OL</sub> = 4 mA	0.4			
Power-up reset voltage <sup>(1)</sup>		V <sub>DD</sub> ≥ 1.1 V, I <sub>OL</sub> = 50 μA	0.2			V
V <sub>IT-</sub>	Negative-going input threshold voltage <sup>(2)</sup>	TPS3809L30	2.58	2.6	2.7	V
		TPS3809K33	2.87	2.9	2.99	
		TPS3809I50	4.45	4.5	4.65	
V <sub>hys</sub>	Hysteresis	TPS3809L30	35			mV
		TPS3809K33	40			
		TPS3809I50	60			
I <sub>DD</sub>	Supply current	V <sub>DD</sub> = 2 V, Output unconnected	9		12	μA
		V <sub>DD</sub> = 6 V, Output unconnected	20		25	
C <sub>i</sub>	Input capacitance	V <sub>I</sub> = 0 V to V <sub>DD</sub>	5			pF

(1) The lowest supply voltage at which **RESET** becomes active. t<sub>r</sub>, V<sub>DD</sub> ≥ 15 μs/V.

(2) To ensure best stability of the threshold voltage, a bypass capacitor (0.1-μF ceramic) should be placed near the supply terminals.

## Timing Requirements

R<sub>L</sub> = 1 MΩ, C<sub>L</sub> = 50 pF, T<sub>A</sub> = 25°C

PARAMETER	TEST CONDITIONS	MIN	MAX	UNIT	
t <sub>w</sub>	Pulse width at V <sub>DD</sub>	V <sub>DD</sub> = V <sub>IT-</sub> + 0.2 V, V <sub>DD</sub> = V <sub>IT-</sub> - 0.2 V		3	μs

## Switching Characteristics

R<sub>L</sub> = 1 MΩ, C<sub>L</sub> = 50 pF, T<sub>A</sub> = 25°C

PARAMETER	TEST CONDITIONS	MIN	TYP	MAX	UNIT			
t <sub>d</sub>	Delay time	V <sub>DD</sub> ≥ V <sub>IT-</sub> + 0.2 V, See timing diagram			120	200	280	ms
t <sub>PHL</sub>	Propagation (delay) time, high- to low-level output	V <sub>DD</sub> to <b>RESET</b> delay		V <sub>IL</sub> = V <sub>IT-</sub> - 0.2 V, V <sub>IH</sub> = V <sub>IT-</sub> + 0.2 V		1	ms	

TYPICAL CHARACTERISTICS

LOW-LEVEL OUTPUT VOLTAGE  
vs  
LOW-LEVEL OUTPUT CURRENT

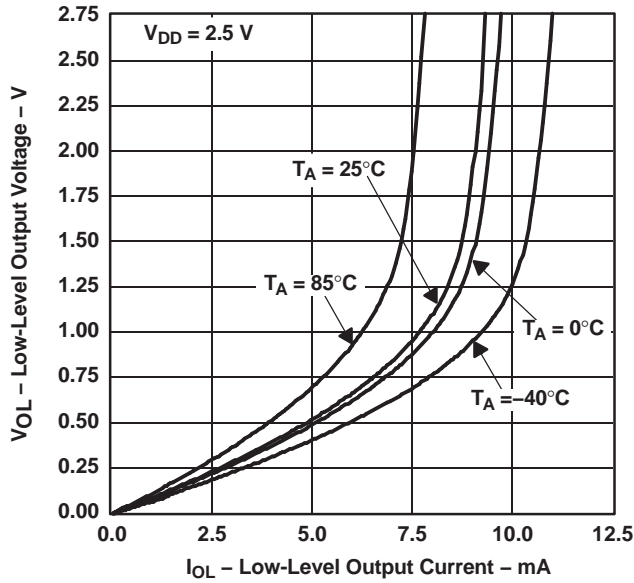

Figure 1.

HIGH-LEVEL OUTPUT VOLTAGE  
vs  
HIGH-LEVEL OUTPUT CURRENT

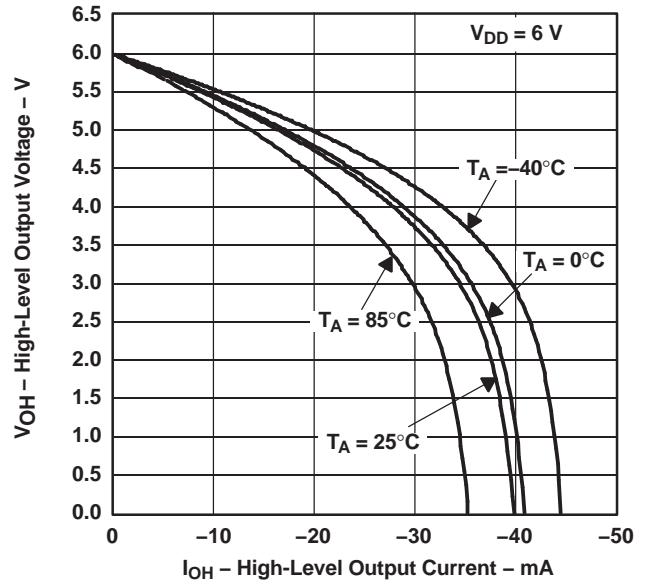

Figure 2.

HIGH-LEVEL OUTPUT VOLTAGE  
vs  
HIGH-LEVEL OUTPUT CURRENT

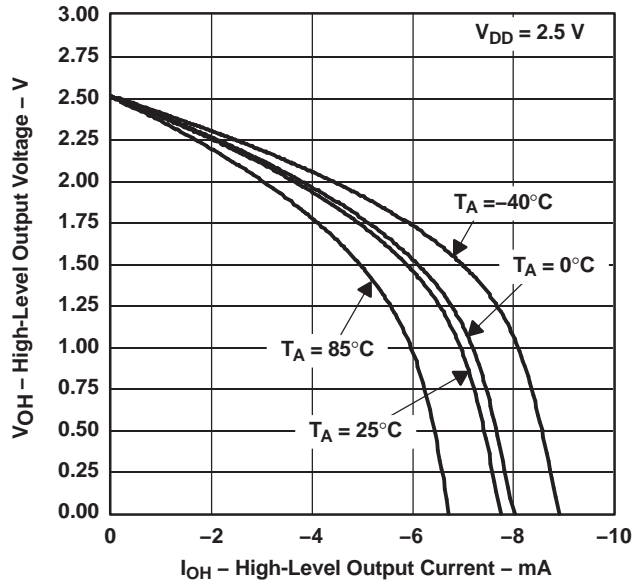

Figure 3.

NORMALIZED INPUT THRESHOLD VOLTAGE  
vs  
FREE-AIR TEMPERATURE AT  $V_{DD}$

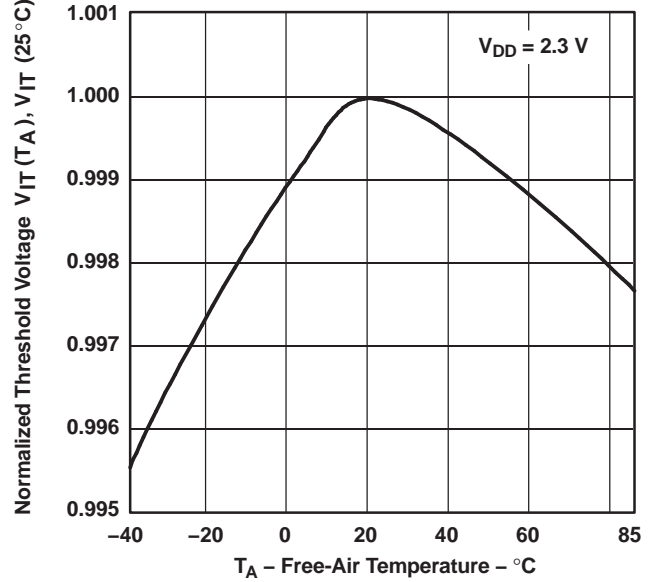

Figure 4.

TYPICAL CHARACTERISTICS (continued)

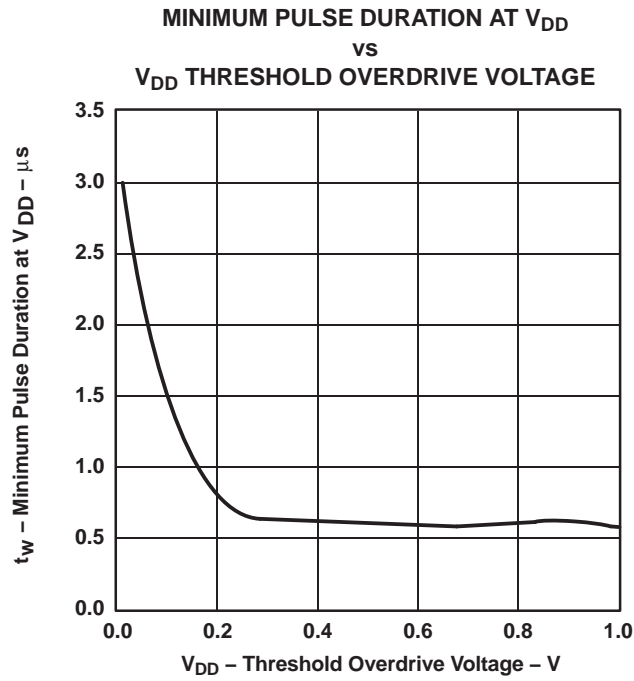

Figure 5.

**PACKAGING INFORMATION**

Orderable Device	Status (1)	Package Type	Package Drawing	Pins	Package Qty	Eco Plan (2)	Lead finish/ Ball material (6)	MSL Peak Temp (3)	Op Temp (°C)	Device Marking (4/5)	Samples
TPS3809I50MDBVREP	ACTIVE	SOT-23	DBV	3	3000	RoHS & Green	NIPDAU	Level-1-260C-UNLIM	-55 to 125	PMAM	<a href="#">Samples</a>
TPS3809K33MDBVREP	ACTIVE	SOT-23	DBV	3	3000	RoHS & Green	NIPDAU	Level-1-260C-UNLIM	-55 to 125	PLZM	<a href="#">Samples</a>
TPS3809L30MDBVREP	ACTIVE	SOT-23	DBV	3	3000	RoHS & Green	NIPDAU	Level-1-260C-UNLIM	-55 to 125	PLYM	<a href="#">Samples</a>
V62/06636-01XE	ACTIVE	SOT-23	DBV	3	3000	RoHS & Green	NIPDAU	Level-1-260C-UNLIM	-55 to 125	PLYM	<a href="#">Samples</a>
V62/06636-02XE	ACTIVE	SOT-23	DBV	3	3000	RoHS & Green	NIPDAU	Level-1-260C-UNLIM	-55 to 125	PLZM	<a href="#">Samples</a>
V62/06636-03XE	ACTIVE	SOT-23	DBV	3	3000	RoHS & Green	NIPDAU	Level-1-260C-UNLIM	-55 to 125	PMAM	<a href="#">Samples</a>

(1) The marketing status values are defined as follows:

**ACTIVE:** Product device recommended for new designs.

**LIFEBUY:** TI has announced that the device will be discontinued, and a lifetime-buy period is in effect.

**NRND:** Not recommended for new designs. Device is in production to support existing customers, but TI does not recommend using this part in a new design.

**PREVIEW:** Device has been announced but is not in production. Samples may or may not be available.

**OBSOLETE:** TI has discontinued the production of the device.

(2) **RoHS:** TI defines "RoHS" to mean semiconductor products that are compliant with the current EU RoHS requirements for all 10 RoHS substances, including the requirement that RoHS substance do not exceed 0.1% by weight in homogeneous materials. Where designed to be soldered at high temperatures, "RoHS" products are suitable for use in specified lead-free processes. TI may reference these types of products as "Pb-Free".

**RoHS Exempt:** TI defines "RoHS Exempt" to mean products that contain lead but are compliant with EU RoHS pursuant to a specific EU RoHS exemption.

**Green:** TI defines "Green" to mean the content of Chlorine (Cl) and Bromine (Br) based flame retardants meet JS709B low halogen requirements of <=1000ppm threshold. Antimony trioxide based flame retardants must also meet the <=1000ppm threshold requirement.

(3) MSL, Peak Temp. - The Moisture Sensitivity Level rating according to the JEDEC industry standard classifications, and peak solder temperature.

(4) There may be additional marking, which relates to the logo, the lot trace code information, or the environmental category on the device.

(5) Multiple Device Markings will be inside parentheses. Only one Device Marking contained in parentheses and separated by a "~" will appear on a device. If a line is indented then it is a continuation of the previous line and the two combined represent the entire Device Marking for that device.

(6) Lead finish/Ball material - Orderable Devices may have multiple material finish options. Finish options are separated by a vertical ruled line. Lead finish/Ball material values may wrap to two lines if the finish value exceeds the maximum column width.

**Important Information and Disclaimer:** The information provided on this page represents TI's knowledge and belief as of the date that it is provided. TI bases its knowledge and belief on information provided by third parties, and makes no representation or warranty as to the accuracy of such information. Efforts are underway to better integrate information from third parties. TI has taken and continues to take reasonable steps to provide representative and accurate information but may not have conducted destructive testing or chemical analysis on incoming materials and chemicals. TI and TI suppliers consider certain information to be proprietary, and thus CAS numbers and other limited information may not be available for release.

In no event shall TI's liability arising out of such information exceed the total purchase price of the TI part(s) at issue in this document sold by TI to Customer on an annual basis.

**OTHER QUALIFIED VERSIONS OF TPS3809-EP :**

- Catalog: [TPS3809](#)
- Automotive: [TPS3809-Q1](#)

NOTE: Qualified Version Definitions:

- Catalog - TI's standard catalog product
- Automotive - Q100 devices qualified for high-reliability automotive applications targeting zero defects

**TAPE AND REEL INFORMATION**

**QUADRANT ASSIGNMENTS FOR PIN 1 ORIENTATION IN TAPE**

\*All dimensions are nominal

Device	Package Type	Package Drawing	Pins	SPQ	Reel Diameter (mm)	Reel Width W1 (mm)	A0 (mm)	B0 (mm)	K0 (mm)	P1 (mm)	W (mm)	Pin1 Quadrant
TPS3809I50MDBVREP	SOT-23	DBV	3	3000	180.0	9.0	3.3	3.2	1.47	4.0	8.0	Q3
TPS3809K33MDBVREP	SOT-23	DBV	3	3000	180.0	9.0	3.3	3.2	1.47	4.0	8.0	Q3
TPS3809L30MDBVREP	SOT-23	DBV	3	3000	180.0	9.0	3.3	3.2	1.47	4.0	8.0	Q3

**TAPE AND REEL BOX DIMENSIONS**

\*All dimensions are nominal

Device	Package Type	Package Drawing	Pins	SPQ	Length (mm)	Width (mm)	Height (mm)
TPS3809I50MDBVREP	SOT-23	DBV	3	3000	182.0	182.0	20.0
TPS3809K33MDBVREP	SOT-23	DBV	3	3000	182.0	182.0	20.0
TPS3809L30MDBVREP	SOT-23	DBV	3	3000	182.0	182.0	20.0

DBV0003A

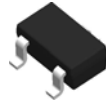

# PACKAGE OUTLINE

SOT-23 - 1.45 mm max height

SMALL OUTLINE TRANSISTOR

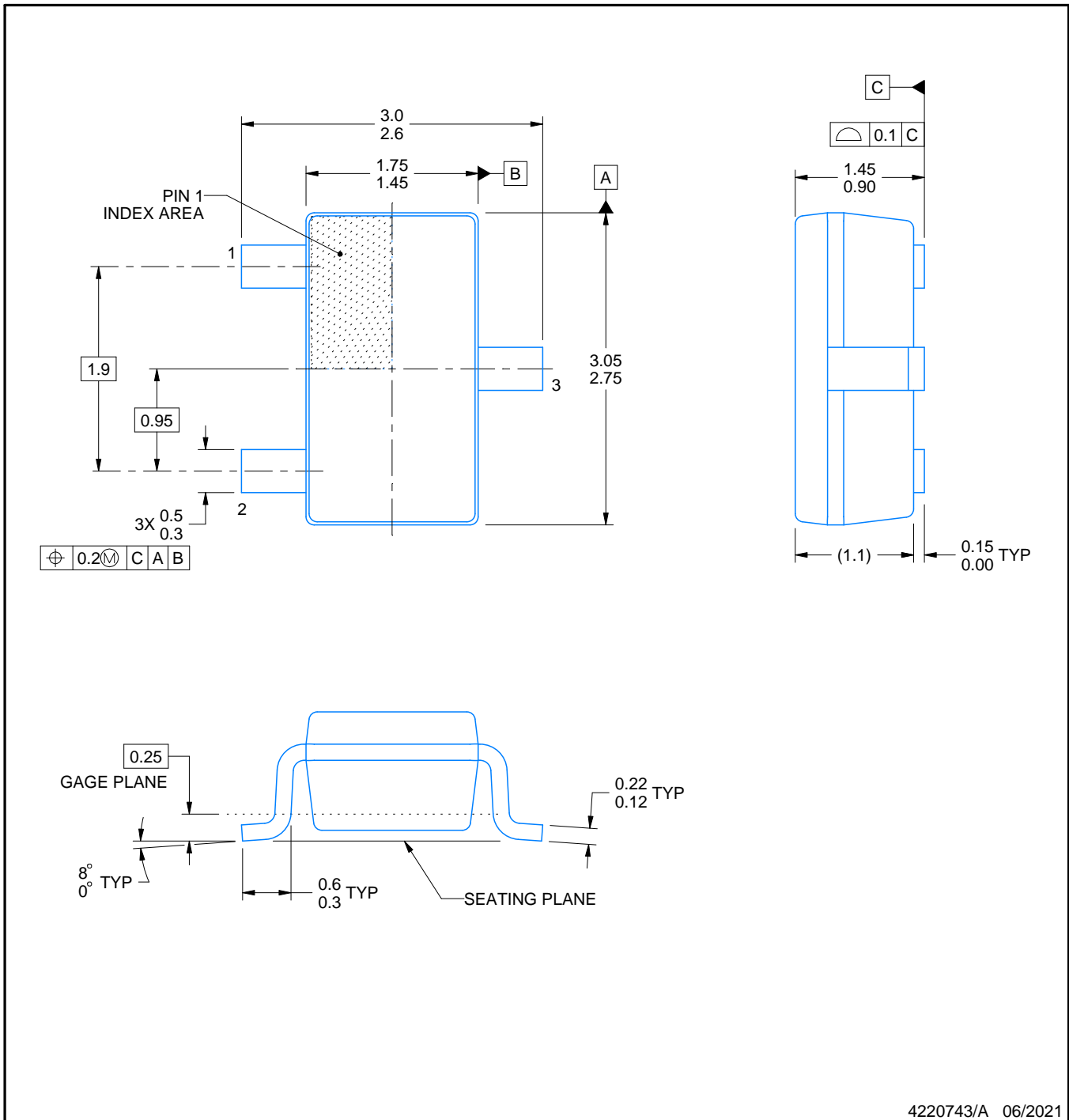

4220743/A 06/2021

## NOTES:

1. All linear dimensions are in millimeters. Any dimensions in parenthesis are for reference only. Dimensioning and tolerancing per ASME Y14.5M.
2. This drawing is subject to change without notice.
3. Reference JEDEC MO-178.
4. Body dimensions do not include mold flash, protrusions, or gate burrs. Mold flash, protrusions, or gate burrs shall not exceed 0.25 mm per side.

# EXAMPLE BOARD LAYOUT

DBV0003A

SOT-23 - 1.45 mm max height

SMALL OUTLINE TRANSISTOR

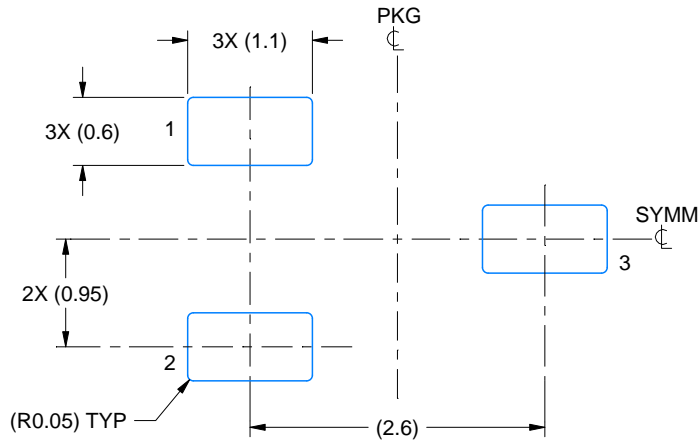

LAND PATTERN EXAMPLE  
EXPOSED METAL SHOWN  
SCALE:15X

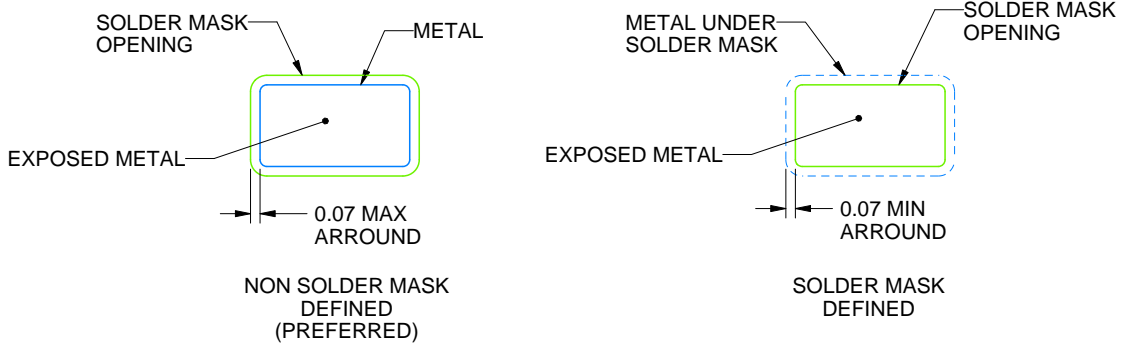

SOLDER MASK DETAILS

4220743/A 06/2021

NOTES: (continued)

- 5. Publication IPC-7351 may have alternate designs.
- 6. Solder mask tolerances between and around signal pads can vary based on board fabrication site.

# EXAMPLE STENCIL DESIGN

DBV0003A

SOT-23 - 1.45 mm max height

SMALL OUTLINE TRANSISTOR

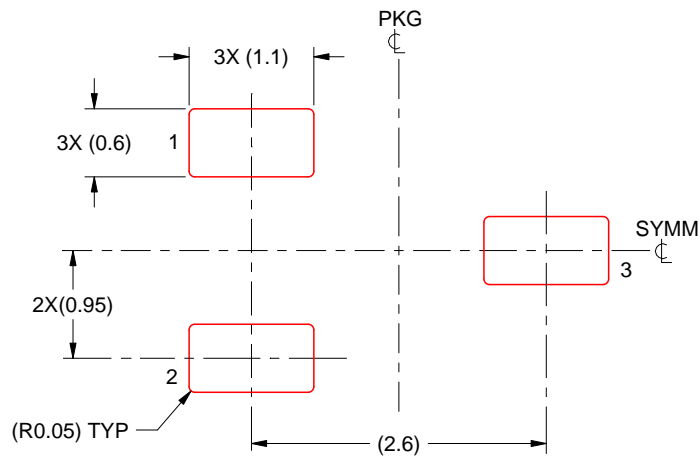

SOLDER PASTE EXAMPLE  
BASED ON 0.125 mm THICK STENCIL  
SCALE:15X

4220743/A 06/2021

NOTES: (continued)

7. Laser cutting apertures with trapezoidal walls and rounded corners may offer better paste release. IPC-7525 may have alternate design recommendations.
8. Board assembly site may have different recommendations for stencil design.

## IMPORTANT NOTICE AND DISCLAIMER

TI PROVIDES TECHNICAL AND RELIABILITY DATA (INCLUDING DATASHEETS), DESIGN RESOURCES (INCLUDING REFERENCE DESIGNS), APPLICATION OR OTHER DESIGN ADVICE, WEB TOOLS, SAFETY INFORMATION, AND OTHER RESOURCES "AS IS" AND WITH ALL FAULTS, AND DISCLAIMS ALL WARRANTIES, EXPRESS AND IMPLIED, INCLUDING WITHOUT LIMITATION ANY IMPLIED WARRANTIES OF MERCHANTABILITY, FITNESS FOR A PARTICULAR PURPOSE OR NON-INFRINGEMENT OF THIRD PARTY INTELLECTUAL PROPERTY RIGHTS.

These resources are intended for skilled developers designing with TI products. You are solely responsible for (1) selecting the appropriate TI products for your application, (2) designing, validating and testing your application, and (3) ensuring your application meets applicable standards, and any other safety, security, or other requirements. These resources are subject to change without notice. TI grants you permission to use these resources only for development of an application that uses the TI products described in the resource. Other reproduction and display of these resources is prohibited. No license is granted to any other TI intellectual property right or to any third party intellectual property right. TI disclaims responsibility for, and you will fully indemnify TI and its representatives against, any claims, damages, costs, losses, and liabilities arising out of your use of these resources.

TI's products are provided subject to TI's Terms of Sale (<https://www.ti.com/legal/termsofsale.html>) or other applicable terms available either on [ti.com](https://www.ti.com) or provided in conjunction with such TI products. TI's provision of these resources does not expand or otherwise alter TI's applicable warranties or warranty disclaimers for TI products.

Mailing Address: Texas Instruments, Post Office Box 655303, Dallas, Texas 75265  
Copyright © 2021, Texas Instruments Incorporated