

SN65HVD23x-Q1 3.3V 汽车类 CAN 总线收发器

1 特性

- 符合 ISO 11898-2 标准
- 适用于汽车电子 应用
- 具有符合 AEC-Q100 标准的下列结果：
 - 器件温度 1 级：-40°C 至 125°C 的环境运行温度范围
 - 器件人体模型 (HBM) 静电放电 (ESD) 分类等级：
 - 总线引脚：±12 000V
 - 其他引脚：±3 000V
 - 器件带电器件模型 (CDM) ESD 分类等级：±1 000V
- 3.3V 单电源电压
- 比特率：最高达 1Mbps
- 总线引脚故障保护：最高达 ±36V
- 7V 至 12V 共模电压范围
- 高输入阻抗，允许连接 120 个节点
- 低电压晶体管-晶体管逻辑电路 (LVTTTL) I/O 可耐受 5V 电压
- 符合 GIFT/ICT 标准
- 可调节的驱动器转换率，能够改善辐射性能
- 未供电节点不会干扰总线
- 低电流待机模式（典型值为 200μA）
- 平均功耗：36.4mW
- SN65HVD233-Q1：环回模式
- SN65HVD234-Q1：超低电流休眠模式
 - 50nA 流耗典型值
- SN65HVD235-Q1：自动波特环回模式
- 热关断保护
- 上电和掉电时总线输入和输出上无毛刺脉冲
 - 高输入阻抗，低 V_{CC}
 - 掉电再上电期间的输出呈单调性

2 应用

- 车内网络
- 先进的驾驶员辅助系统 (ADAS)
- 车身电子装置和照明
- 信息娱乐和仪表盘
- 混合、电动和动力传动系统
- 符合 CAN 总线标准（例如，NMEA 2000 和 SAE J1939）的应用

3 说明

SN65HVD233-Q1、SN65HVD234-Q1 和 SN65HVD235-Q1 器件是适用于汽车类应用的 3.3V 故障保护 CAN 收发器。这些收发器由 3.3V 单电源供电运行，非常适合同样采用 3.3V 微控制器的系统，因为不再需要通过附加组件或独立电源分别为控制器和 CAN 收发器供电。SN65HVD23x-Q1 收发器符合 ISO 11898-2 标准，因此可在使用 5V CAN 和/或 3.3V CAN 收发器的混合网络中进行互操作。

这些器件尤其适合工作在恶劣环境下，其具有串线保护、过压保护（CANH 和 CANL 引脚上，最高达 ±36V）、接地损耗保护、过热（热关断）保护以及 ±100V 共模瞬态保护。这些器件工作在 -7V 至 12V 的宽共模电压范围内。这些收发器可用作微处理器上的主机 CAN 控制器与运输及汽车应用中的差分 CAN 总线之间的接口。

器件信息⁽¹⁾

器件型号	封装	封装尺寸（标称值）
SN65HVD233-Q1	SOIC (8)	4.90mm x 3.91mm
SN65HVD234-Q1		
SN65HVD235-Q1		

(1) 要了解所有可用封装，请见数据表末尾的可订购产品附录。

框图

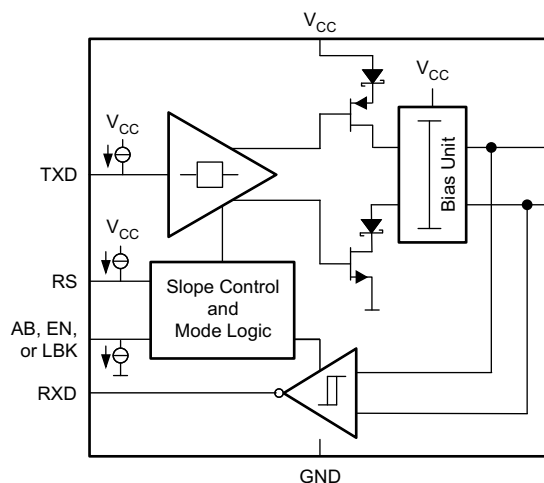

目录

1	特性	1	10.1	Overview	18
2	应用	1	10.2	Functional Block Diagrams	18
3	说明	1	10.3	Feature Description	18
4	修订历史记录	2	10.4	Device Functional Modes	20
5	说明 (续)	3	11	Application and Implementation	22
6	Device Comparison Table	3	11.1	Application Information	22
7	Pin Configuration and Functions	4	11.2	Typical Application	23
8	Specifications	5	11.3	System Example	25
8.1	Absolute Maximum Ratings	5	12	Power Supply Recommendations	26
8.2	ESD Ratings	5	13	Layout	26
8.3	Recommended Operating Conditions	5	13.1	Layout Guidelines	26
8.4	Thermal Information	6	13.2	Layout Example	27
8.5	Electrical Characteristics: Driver	6	14	器件和文档支持	28
8.6	Electrical Characteristics: Receiver	7	14.1	相关链接	28
8.7	Switching Characteristics: Driver	7	14.2	接收文档更新通知	28
8.8	Switching Characteristics: Receiver	8	14.3	社区资源	28
8.9	Switching Characteristics: Device	8	14.4	商标	28
8.10	Typical Characteristics	9	14.5	静电放电警告	28
9	Parameter Measurement Information	11	14.6	Glossary	28
10	Detailed Description	18	15	机械、封装和可订购信息	28

4 修订历史记录

注：之前版本的页码可能与当前版本有所不同。

Changes from Original (September 2016) to Revision A	Page
• Deleted extra words "all pins except" in the test condition for CANH, CANL pins to GND	5
• Added ESD performance information between CANH and CANL pins	5

5 说明（续）

模式： SN65HVD233-Q1、SN65HVD234-Q1 和 SN65HVD235-Q1 器件的 RS 引脚（引脚 8）提供三种工作模式：高速、斜率控制和低功耗待机模式。将引脚 8 直接接地可选择高速工作模式，该工作模式允许驱动器输出晶体管以尽可能快的速度导通和关断，而且对上升和下降斜率没有限制。通过在 RS 引脚与地之间串联一个电阻可以调节上升和下降斜率。斜率与引脚的输出电流成比例。当电阻值为 10kΩ 时，器件的转换率约为 15V/μs；当电阻值为 100kΩ 时，器件的转换率约为 2V/μs。有关斜率控制的更多信息，请参见 [Feature Description](#)。

如果对 RS 引脚施加逻辑高电平，SN65HVD233-Q1、SN65HVD234-Q1 和 SN65HVD235-Q1 器件将进入低电流待机（仅监听）模式。在此模式下，驱动器将关断、接收器保持工作状态。如果本地协议控制器必须向总线发送消息，则它必须同时通过 RS 引脚使器件返回高速模式或斜率控制模式。

环回 (SN65HVD233-Q1)： 当 SN65HVD233-Q1 器件的环回 (LBK) 引脚（引脚 5）为逻辑高电平时，会将总线输出和总线输入置于高阻抗状态。器件内部的 TXD 至 RS 路径保持有效状态，可用于驱动器至接收器环回，从而实现在不干扰总线的情况下执行自诊断节点功能。关于环回模式的更多信息，请参见 [Feature Description](#)。

超低电流休眠 (SN65HVD234-Q1)： 如果向 EN 引脚（引脚 5）施加逻辑低电平，则 SN65HVD234-Q1 器件将进入超低电流休眠模式，继而将禁止驱动器和接收器电路。在通过向引脚 5 施加逻辑高电平来激活电路之前，该器件将保持在该休眠模式下。

自动波特环回 (SN65HVD235-Q1)： SN65HVD235-Q1 器件的 AB 引脚（引脚 5）实现了总线仅监听环回功能，允许本地节点控制器将其波特率与 CAN 总线的波特率同步。在自动波特模式下，驱动器的总线输出处于高阻抗状态，而接收器的总线输入保持有效状态。器件内部有一条 TXD 引脚到 RS 引脚的环回路径，方便控制器执行波特率检测或自动波特功能。关于自动波特模式的更多信息，请参见 [Feature Description](#)。

6 Device Comparison Table

PART NUMBER ⁽¹⁾	LOW-POWER MODE	SLOPE CONTROL	DIAGNOSTIC LOOPBACK	AUTOBAUD LOOPBACK
SN65HVD233-Q1	200-μA standby mode	Adjustable	Yes	No
SN65HVD234-Q1	200-μA standby mode or 50-nA sleep mode	Adjustable	No	No
SN65HVD235-Q1	200-μA standby mode	Adjustable	No	Yes

(1) For the most-current package and ordering information, see the orderable addendum at the end of the data sheet, or see the TI Web site at www.ti.com.

7 Pin Configuration and Functions

**D Package
8-Pin SOIC
SN65HVD233-Q1 Top View**

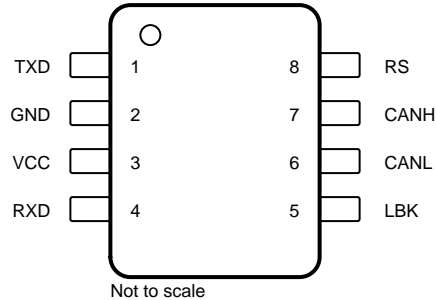

**D Package
8-Pin SOIC
SN65HVD234-Q1 Top View**

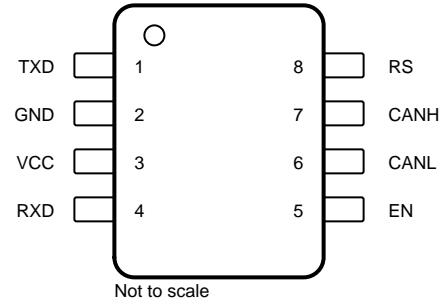

**D Package
8-Pin SOIC
SN65HVD235-Q1 Top View**

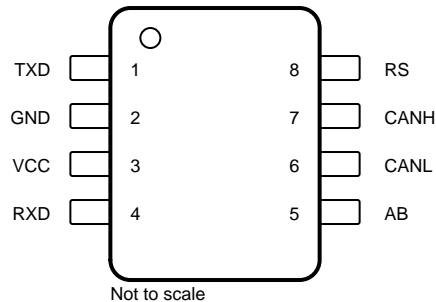

Pin Functions

NAME	PIN NO.			I/O	DESCRIPTION
	'233-Q1	'234-Q1	'235-Q1		
AB	—	—	5	I	SN65HVD235-Q1 device: Autobaud loopback mode-input pin (AB). Can be tied to ground if not used. Can also be left open if unused because the internal pulldown biases this toward ground.
CANH	7	7	7	I/O	High-level CAN bus line
CANL	6	6	6	I/O	Low-level CAN bus line
EN	—	5	—	I	SN65HVD234-Q1 device: Enable input pin. Logic high for enabling a normal mode (high-speed or slope-control mode). Logic low for sleep mode. (EN)
GND	2	2	2	—	Ground connection
LBK	5	—	—	I	SN65HVD233-Q1 device: Loopback-mode input pin (LBK). Can be tied to ground if not used. Can also be left open if unused because the internal pulldown biases this toward ground.
RS	8	8	8	I	Mode-select pin: strong pulldown to GND = high-speed mode, strong pullup to V_{CC} = low-power mode, 10-k Ω to 100-k Ω pulldown to GND = slope-control mode
RXD	4	4	4	O	CAN receive data output (LOW for dominant and HIGH for recessive bus states)
TXD	1	1	1	I	CAN transmit data input (LOW for dominant and HIGH for recessive bus states)
V_{CC}	3	3	3	I	Transceiver 3.3-V supply voltage

8 Specifications

8.1 Absolute Maximum Ratings

over operating ambient temperature range unless otherwise noted⁽¹⁾⁽²⁾

		MIN	MAX	UNIT	
V _{CC}	Supply voltage	-0.3	7	V	
	Voltage at any bus terminal (CANH or CANL)		-36	36	V
	Voltage input, transient pulse, CANH and CANL, through 100 Ω (see Figure 18)		-100	100	V
V _I	Input voltage, (AB, EN, LBK, RS, TXD)	-0.5	7	V	
V _O	Output voltage (RXD)	-0.5	7	V	
I _O	Receiver output current	-10	10	mA	
T _J	Operating junction temperature	-40	150	°C	
T _{stg}	Storage temperature		125	°C	

- (1) Stresses beyond those listed under *Absolute Maximum Ratings* may cause permanent damage to the device. These are stress ratings only, and functional operation of the device at these or any other conditions beyond those indicated under *Recommended Operating Conditions* is not implied. Exposure to absolute-maximum-rated conditions for extended periods may affect device reliability.
- (2) All voltage values, except differential I/O bus voltages, are with respect to the network ground pin.

8.2 ESD Ratings

			VALUE	UNIT	
V _(ESD)	Electrostatic discharge	Human-body model (HBM), per AEC Q100-002 ⁽¹⁾	CANH, CANL to GND	±12 000	V
			Between CANH and CANL	±16 000	
			All pins	±3 000	
		Charged-device model (CDM), per AEC Q100-011	±1 000		

- (1) AEC Q100-002 indicates that HBM stressing shall be in accordance with the ANSI/ESDA/JEDEC JS-001 specification.

8.3 Recommended Operating Conditions

			MIN	MAX	UNIT
V _{CC}	Supply voltage		3	3.6	V
	Voltage at any bus terminal (separately or common mode)		-7	12	V
V _{IH}	High-level input voltage	EN, AB, LBK, TXD	2	5.5	V
V _{IL}	Low-level input voltage	EN, AB, LBK, TXD	0	0.8	V
V _{ID}	Differential input voltage between CANH and CANL		-6	6	V
	Resistance from RS to ground		0	100	kΩ
V _{I(RS)}	Input voltage at RS for standby		0.75 V _{CC}	5.5	V
I _{OH}	High-level output current	Driver	-50		mA
		Receiver	-10		
I _{OL}	Low-level output current	Driver		50	mA
		Receiver		10	
T _A	Operating ambient temperature ⁽¹⁾		-40	125	°C

- (1) Maximum ambient temperature operation is allowed as long as the device maximum junction temperature is not exceeded.

8.4 Thermal Information

THERMAL METRIC ⁽¹⁾		SN65HVD23x-Q1	
		D (SOIC)	
		8 PINS	
Symbol	Description	Value	UNIT
$R_{\theta JA}$	Junction-to-ambient thermal resistance	102.8	°C/W
$R_{\theta JC(top)}$	Junction-to-case (top) thermal resistance	45.1	°C/W
$R_{\theta JB}$	Junction-to-board thermal resistance	43.8	°C/W
ψ_{JT}	Junction-to-top characterization parameter	7.3	°C/W
ψ_{JB}	Junction-to-board characterization parameter	43.2	°C/W

(1) For more information about traditional and new thermal metrics, see the *Semiconductor and IC Package Thermal Metrics* application report, [SPRA953](#).

8.5 Electrical Characteristics: Driver

over operating ambient temperature range (unless otherwise noted)

PARAMETER			TEST CONDITIONS	MIN	TYP ⁽¹⁾	MAX	UNIT
$V_{O(D)}$	Bus output voltage (dominant)	CANH	TXD at 0 V, RS at 0 V, see Figure 12 and Figure 13	2.45		V_{CC}	V
		CANL		0.5		1.25	
V_O	Bus output voltage (recessive)	CANH	TXD at 3 V, RS at 0 V, see Figure 12 and Figure 13	2.3			V
		CANL		2.3			
$V_{OD(D)}$	Differential output voltage (dominant)		TXD at 0 V, RS at 0 V, see Figure 12 and Figure 13	1.5	2	3	V
				TXD at 0 V, RS at 0 V, see Figure 13 and Figure 14	1.2	2	
V_{OD}	Differential output voltage (recessive)		TXD at 3 V, RS at 0 V, see Figure 12 and Figure 13		-120		12
				TXD at 3 V, RS at 0 V, no load	-0.5		0.05
$V_{OC(pp)}$	Peak-to-peak common-mode output voltage	See Figure 21			1		V
I_{IH}	High-level input current	AB, EN, LBK, TXD	TXD = 2 V or EN = 2 V or LBK = 2 V or AB = 2 V	-30		30	μA
I_{IL}	Low-level input current	AB, EN, LBK, TXD	TXD = 0.8 V or EN = 0.8 V or LBK = 0.8 V or AB = 0.8 V	-30		30	μA
I_{OS}	Short-circuit output current		$V_{CANH} = -7$ V, CANL open, see Figure 26	-250			mA
			$V_{CANH} = 12$ V, CANL open, see Figure 26			1	
			$V_{CANL} = -7$ V, CANH open, see Figure 26	-1			
			$V_{CANL} = 12$ V, CANH open, see Figure 26			250	
C_O	Output capacitance		See C_I , Input capacitance in Electrical Characteristics: Receiver				
$I_{IRs(s)}$	RS input current for standby		RS at 0.75 V_{CC}	-10			μA
I_{CC}	Supply current	Sleep	EN at 0 V, TXD at V_{CC} , RS at 0 V or V_{CC}	0.05		2	μA
		Standby	RS at V_{CC} , TXD at V_{CC} , AB at 0 V, LBK at 0 V, EN at V_{CC}	200	600		
		Dominant	TXD at 0 V, no load, AB at 0 V, LBK at 0 V, RS at 0 V, EN at V_{CC}			6	mA
		Recessive	TXD at V_{CC} , no load, AB at 0 V, LBK at 0 V, RS at 0 V, EN at V_{CC}			6	
$P_{(AVG)}$	Average power dissipation		$R_L = 60 \Omega$, R_S at 0 V, input to D a 1-MHz 50% duty cycle square wave V_{CC} at 3.3 V, $T_A = 25^\circ\text{C}$	36.4			mW

(1) All typical values are at 25°C and with a 3.3-V supply.

8.6 Electrical Characteristics: Receiver

over operating ambient temperature range (unless otherwise noted)

PARAMETER		TEST CONDITIONS	MIN	TYP ⁽¹⁾	MAX	UNIT	
V _{IT+}	Positive-going input threshold voltage	AB at 0 V, LBK at 0 V, EN at V _{CC} , see Table 1		750	900	mV	
V _{IT-}	Negative-going input threshold voltage		500	650		mV	
V _{hys}	Hysteresis voltage (V _{IT+} – V _{IT-})			100		mV	
V _{OH}	High-level output voltage	I _O = –4 mA, See Figure 17	0.8 × V _{CC}			V	
V _{OL}	Low-level output voltage	I _O = 4 mA, See Figure 17			0.4	V	
I _I	Bus input current	CANH or CANL at 12 V	Other bus pin at 0 V, TXD at 3 V, AB at 0 V, LBK at 0 V, RS at 0 V, EN at V _{CC}	150	500	μA	
		CANH or CANL at 12 V, V _{CC} at 0 V		200	600		
		CANH or CANL at –7 V		–610	–150		
		CANH or CANL at –7 V, V _{CC} at 0 V		–450	–130		
C _I	Input capacitance (CANH or CANL)	Pin-to-ground, V _I = 0.4 sin(4E6πt) + 0.5 V, TXD at 3 V, AB at 0 V, LBK at 0 V, EN at V _{CC}		40		pF	
C _{ID}	Differential input capacitance	Pin-to-pin, V _I = 0.4 sin(4E6πt) + 0.5 V, TXD at 3 V, AB at 0 V, LBK at 0 V, EN at V _{CC}		20		pF	
R _{ID}	Differential input resistance	TXD at 3 V, AB at 0 V, LBK at 0 V, EN at V _{CC}	40		100	kΩ	
R _{IN}	Input resistance (CANH or CANL) to ground		20		50	kΩ	
I _{CC}	Supply current	Sleep	EN at 0 V, TXD at V _{CC} , RS at 0 V or V _{CC}	0.05	2	μA	
		Standby	RS at V _{CC} , TXD at V _{CC} , AB at 0 V, LBK at 0 V, EN at V _{CC}	200	600		
		Dominant	TXD at 0 V, no load, RS at 0 V, LBK at 0 V, AB at 0 V, EN at V _{CC}			6	mA
		Recessive	TXD at V _{CC} , no load, RS at 0 V, LBK at 0 V, AB at 0 V, EN at V _{CC}			6	

(1) All typical values are at 25°C and with a 3.3-V supply.

8.7 Switching Characteristics: Driver

over operating ambient temperature range (unless otherwise noted)

PARAMETER		TEST CONDITIONS	MIN	TYP ⁽¹⁾	MAX	UNIT
t _{PLH}	Propagation delay time, low-to-high-level output	RS at 0 V, see Figure 15		35	85	ns
		RS with 10 kΩ to ground, see Figure 15		70	125	
		RS with 100 kΩ to ground, see Figure 15		500	870	
t _{PHL}	Propagation delay time, high-to-low-level output	RS at 0 V, see Figure 15		70	120	ns
		RS with 10 kΩ to ground, see Figure 15		130	180	
		RS with 100 kΩ to ground, see Figure 15		870	1200	
t _{sk(p)}	Pulse skew ((t _{PHL} – t _{PLH}))	RS at 0 V, see Figure 15		35		ns
		RS with 10 kΩ to ground, see Figure 15		60		
		RS with 100 kΩ to ground, see Figure 15		370		
t _r	Differential output signal rise time	RS at 0 V, see Figure 15	20		70	ns
		RS with 10 kΩ to ground, see Figure 15	30		135	
		RS with 100 kΩ to ground, see Figure 15	350		1400	
t _f	Differential output signal fall time	RS at 0 V, see Figure 15	20		70	ns
		RS with 10 kΩ to ground, see Figure 15	30		135	
		RS with 100 kΩ to ground, see Figure 15	350		1400	
t _{en(s)}	Enable time from standby to dominant	See Figure 19 and Figure 20		0.6	1.5	μs
t _{en(z)}	Enable time from sleep to dominant			1	5	μs

(1) All typical values are at 25°C and with a 3.3-V supply.

8.8 Switching Characteristics: Receiver

over operating ambient temperature range (unless otherwise noted)

PARAMETER		TEST CONDITIONS	MIN	TYP ⁽¹⁾	MAX	UNIT
t_{PLH}	Propagation delay time, CANH input low to RXD output high	See Figure 17		35	60	ns
t_{PHL}	Propagation delay time, CANH input high to RXD output low			35	60	ns
$t_{sk(p)}$	Pulse skew ($ t_{PHL} - t_{PLH} $)			7		ns
t_r	Output signal rise time			2	5	ns
t_f	Output signal fall time			2	5	ns

(1) All typical values are at 25°C and with a 3.3-V supply.

8.9 Switching Characteristics: Device

over operating ambient temperature range (unless otherwise noted)

PARAMETER		TEST CONDITIONS	MIN	TYP ⁽¹⁾	MAX	UNIT
$t_{(LBK)}$	Loopback delay, driver input to receiver output	'HVD233-Q1 See Figure 23		7.5	12	ns
$t_{(AB1)}$	Loopback delay, driver input to receiver output	'HVD235-Q1 See Figure 24		10	20	ns
$t_{(AB2)}$	Loopback delay, bus input to receiver output		See Figure 25		35	60
$t_{(loop1)}$	Total loop delay, driver input to receiver output, recessive to dominant	RS at 0 V, see Figure 22		70	135	ns
		RS with 10 k Ω to ground, see Figure 22		105	190	
		RS with 100 k Ω to ground, see Figure 22		535	1000	
$t_{(loop2)}$	Total loop delay, driver input to receiver output, dominant to recessive	RS at 0 V, see Figure 22		70	135	ns
		RS with 10 k Ω to ground, see Figure 22		105	190	
		RS with 100 k Ω to ground, see Figure 22		535	1000	

(1) All typical values are at 25°C and with a 3.3-V supply.

8.10 Typical Characteristics

RS = LBK = AB = 0 V; EN = V_{CC}

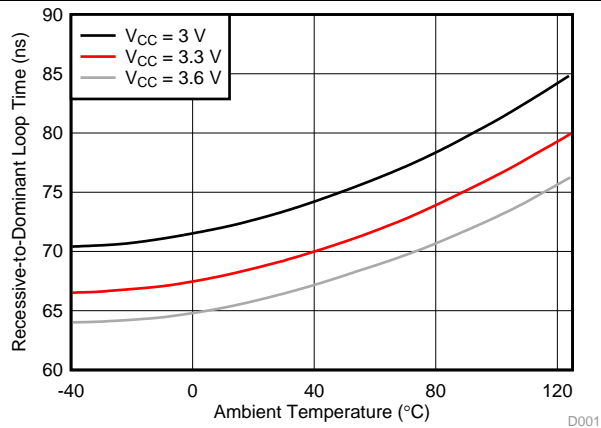

Figure 1. Recessive-to-Dominant Loop Time vs Ambient Temperature

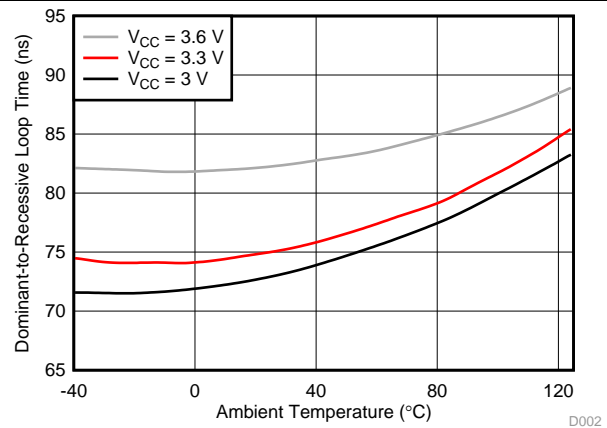

Figure 2. Dominant-to-Recessive Loop Time vs Ambient Temperature

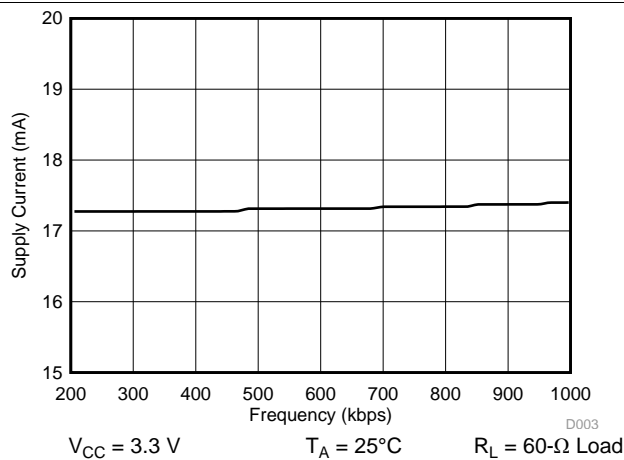

Figure 3. Supply Current vs Frequency

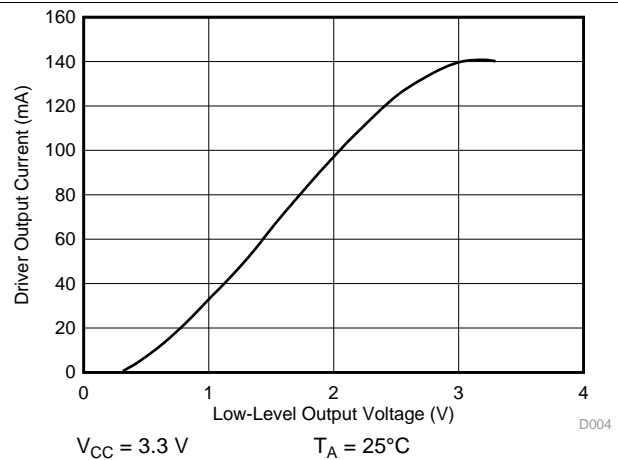

Figure 4. Driver Low-Level Output Current vs Low-Level Output Voltage

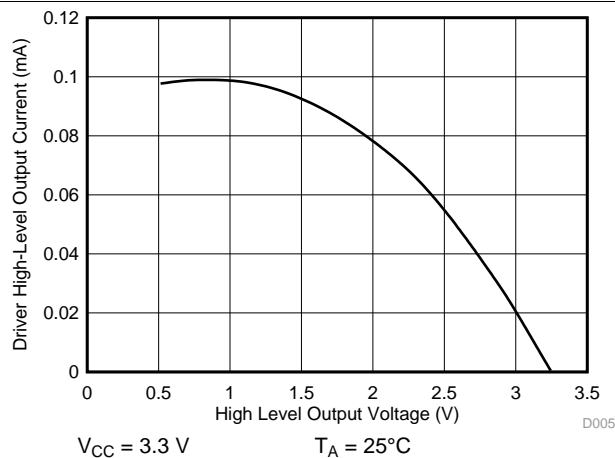

Figure 5. Driver High-Level Output Current vs High-Level Output Voltage

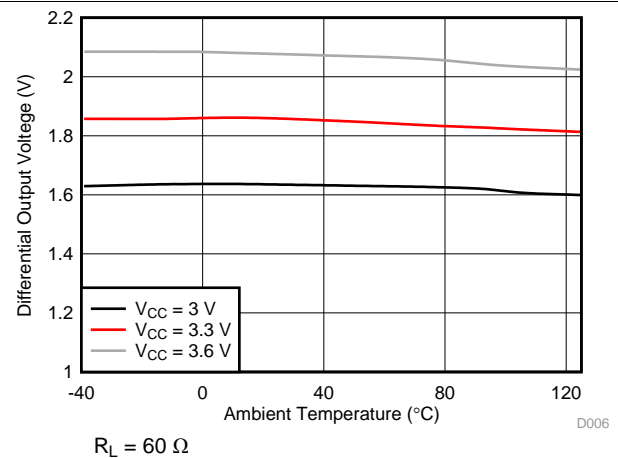
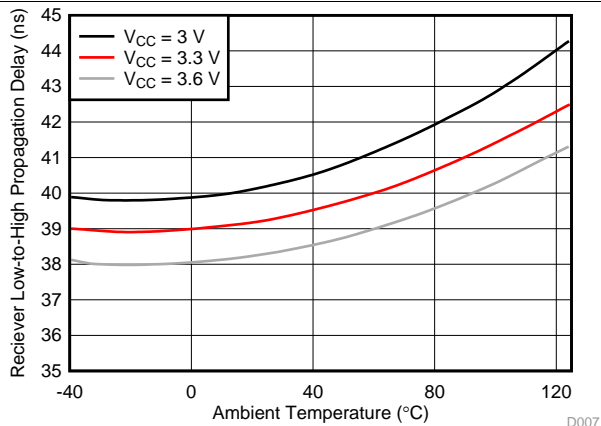

Figure 6. Differential Output Voltage vs Ambient Temperature

Typical Characteristics (continued)

RS = LBK = AB = 0 V; EN = V_{CC}



See Figure 3

Figure 7. Receiver Low-to-High Propagation Delay vs Ambient Temperature

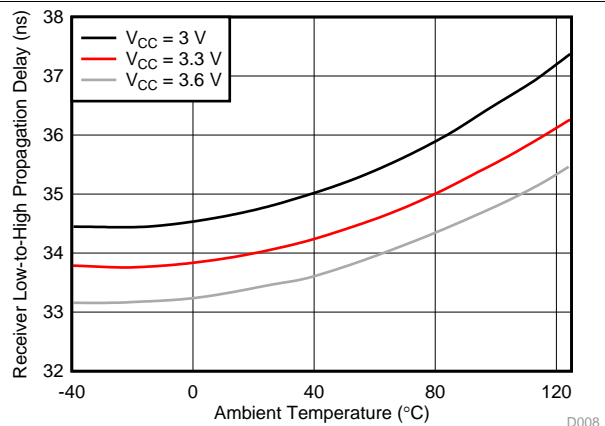

See Figure 3

Figure 8. Receiver High-to-Low Propagation Delay vs Ambient Temperature

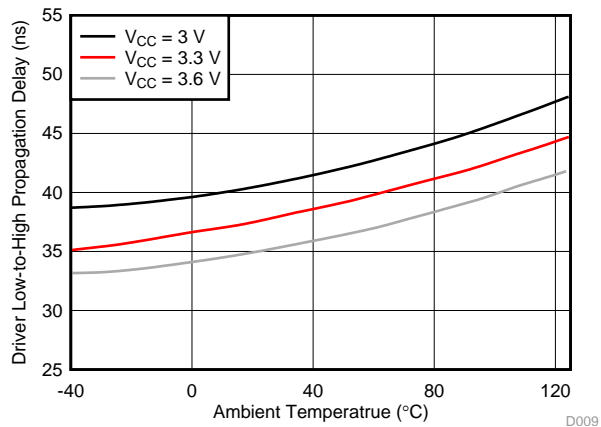

See Figure 1

Figure 9. Driver Low-to-High Propagation Delay vs Ambient Temperature

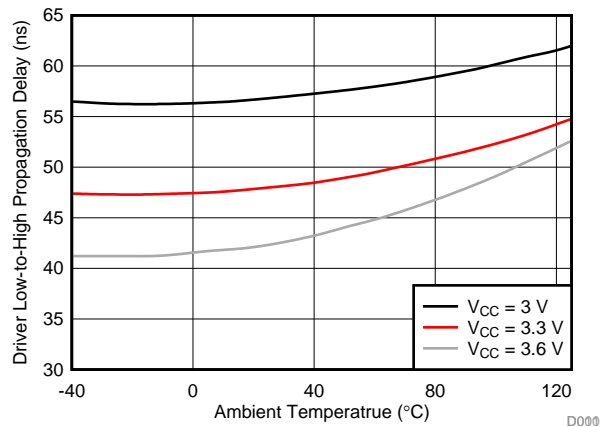

See Figure 1

Figure 10. Driver High-to-Low Propagation Delay vs Ambient Temperature

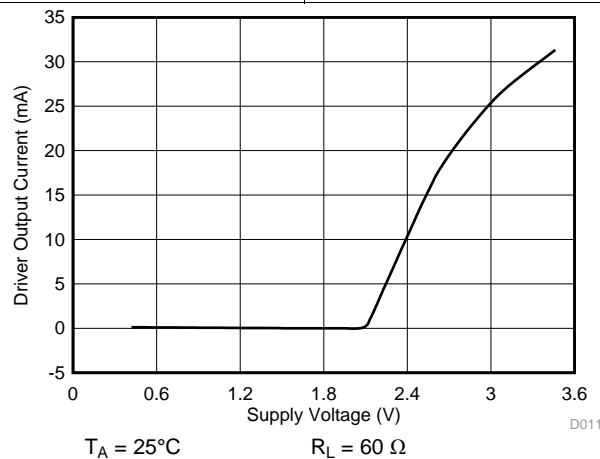

Figure 11. Driver Output Current vs Supply Voltage

9 Parameter Measurement Information

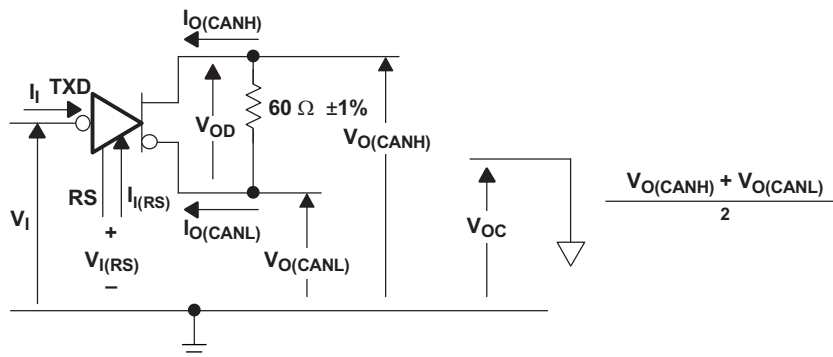

Figure 12. Driver Voltage, Current, and Test Definition

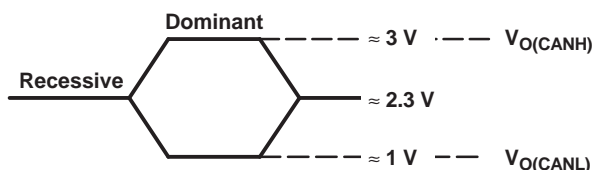

Figure 13. Bus Logic State Voltage Definitions

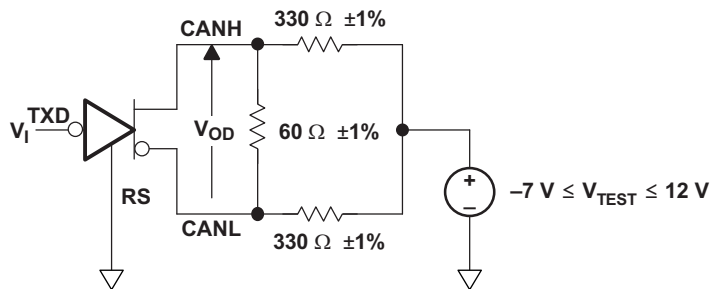
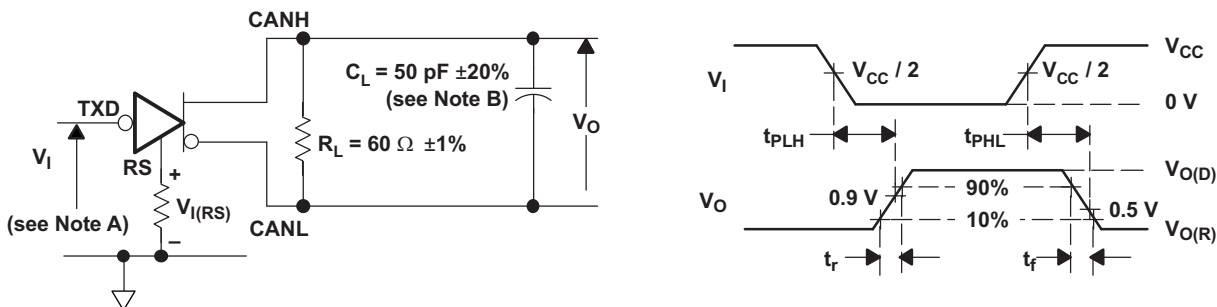

Figure 14. Driver V_{OD}



- A. The input pulse is supplied by a generator having the following characteristics: Pulse repetition rate (PRR) \leq 125 kHz, 50% duty cycle, $t_r \leq 6$ ns, $t_f \leq 6$ ns, $Z_0 = 50 \Omega$.
- B. C_L includes fixture and instrumentation capacitance.

Figure 15. Driver Test Circuit and Voltage Waveforms

Parameter Measurement Information (continued)

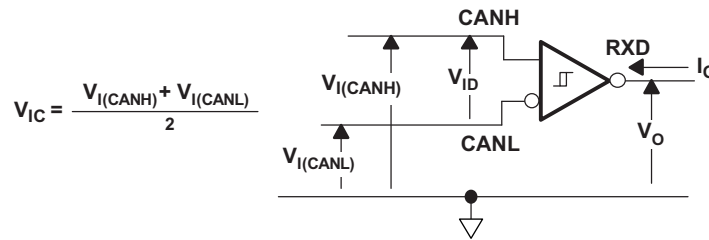
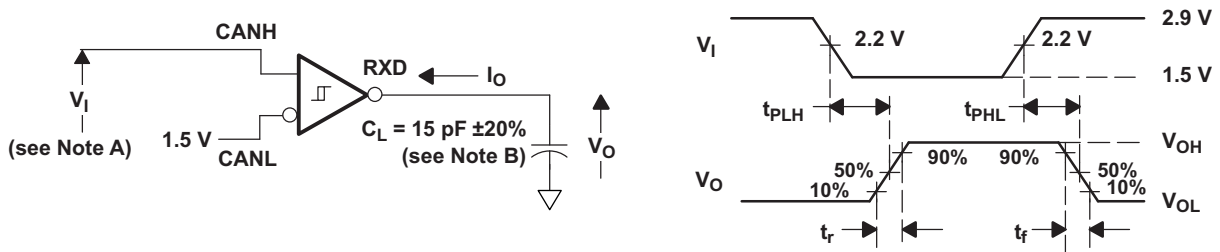

Figure 16. Receiver Voltage and Current Definitions



- A. The input pulse is supplied by a generator having the following characteristics: Pulse repetition rate (PRR) ≤ 125 kHz, 50% duty cycle, $t_r \leq 6$ ns, $t_f \leq 6$ ns, $Z_O = 50 \Omega$.
- B. C_L includes fixture and instrumentation capacitance.

Figure 17. Receiver Test Circuit and Voltage Waveforms

Table 1. Differential Input Voltage Threshold Test

INPUT		OUTPUT	MEASURED	
V_{CANH}	V_{CANL}	RXD	$ V_{ID} $	
-6.1 V	-7 V	L	V _{OL}	900 mV
12 V	11.1 V	L		900 mV
-1 V	-7 V	L		6 V
12 V	6 V	L		6 V
-6.5 V	-7 V	H	V _{OH}	500 mV
12 V	11.5 V	H		500 mV
-7 V	-1 V	H		6 V
6 V	12 V	H		6 V
Open	Open	H		X

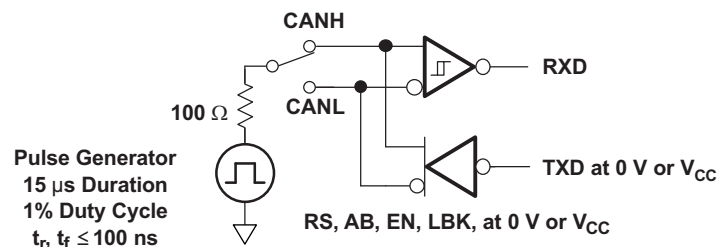

NOTE: This test is conducted to test survivability only. Data stability at the RXD output is not specified.

Figure 18. Test Circuit, Transient Overvoltage Test

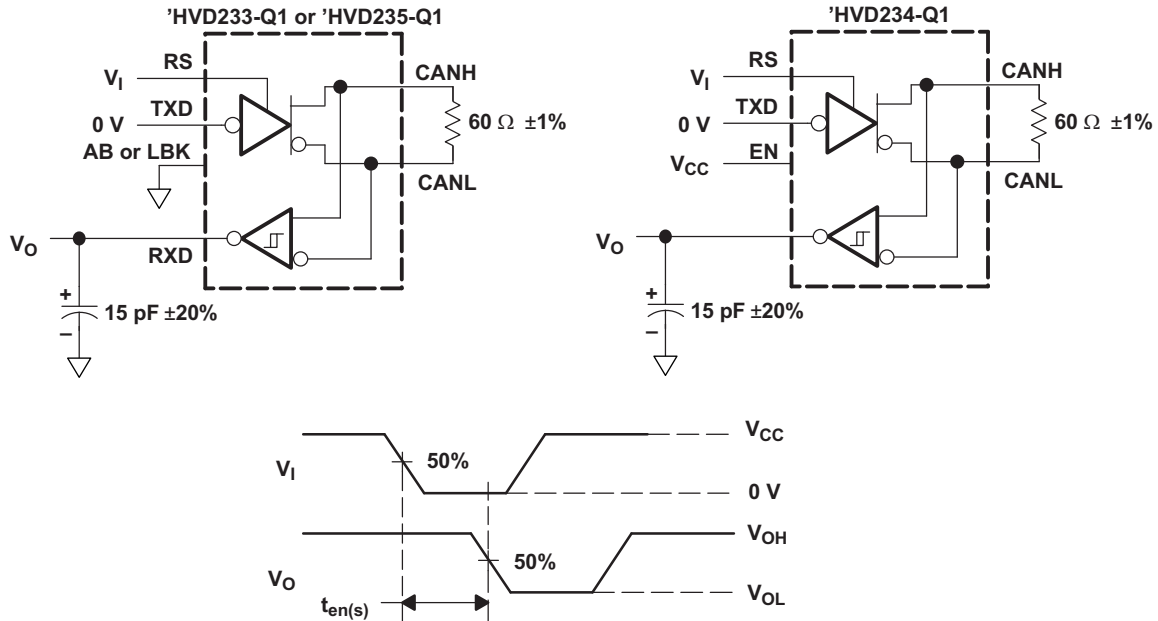

Copyright © 2016, Texas Instruments Incorporated

NOTE: All V_1 input pulses are supplied by a generator having the following characteristics: t_r or $t_f \leq 6$ ns, pulse repetition rate (PRR) = 125 kHz, 50% duty cycle.

Figure 19. $t_{en(s)}$ Test Circuit and Voltage Waveforms

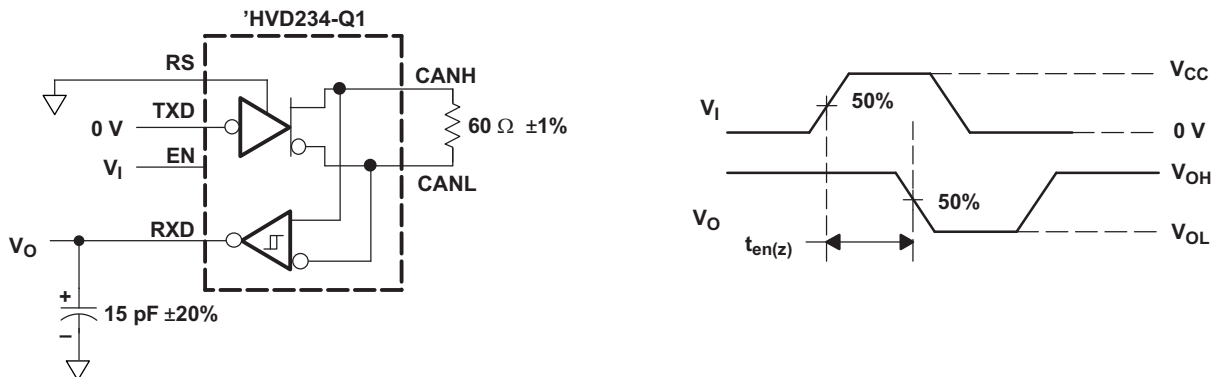

NOTE: All V_1 input pulses are supplied by a generator having the following characteristics: t_r or $t_f \leq 6$ ns, pulse repetition rate (PRR) = 50 kHz, 50% duty cycle.

Copyright © 2016, Texas Instruments Incorporated

Figure 20. $t_{en(z)}$ Test Circuit and Voltage Waveforms

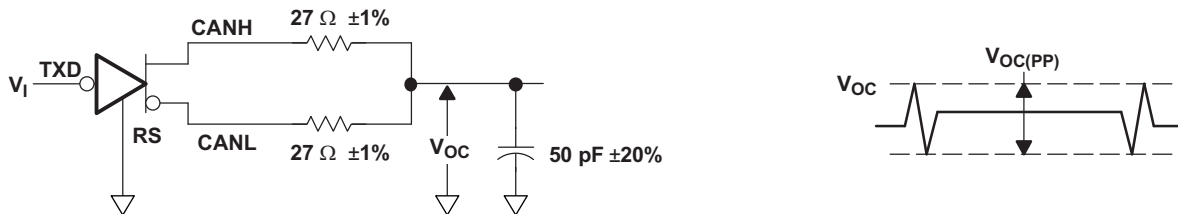

NOTE: All V_1 input pulses are supplied by a generator having the following characteristics: t_r or $t_f \leq 6$ ns, pulse repetition rate (PRR) = 125 kHz, 50% duty cycle.

Figure 21. $V_{OC(pp)}$ Test Circuit and Voltage Waveforms

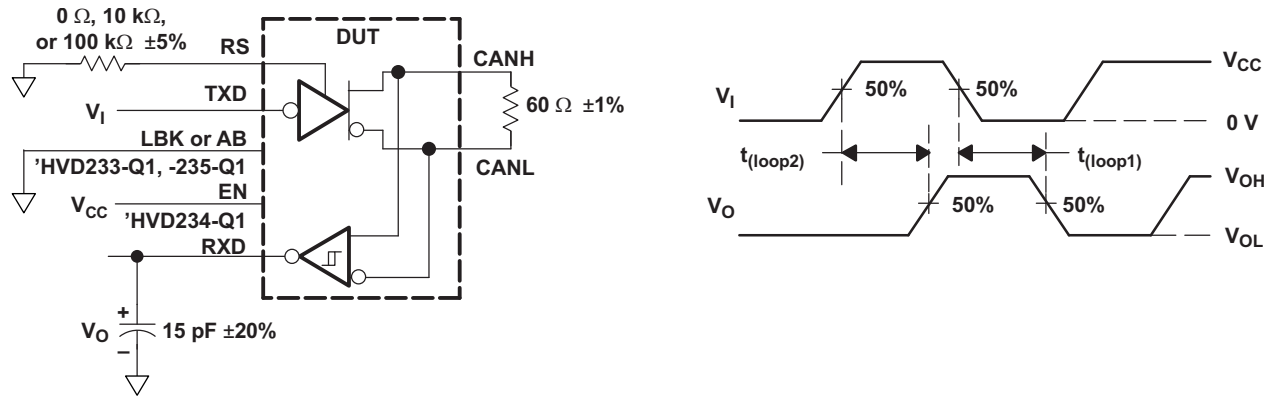

NOTE: All V_I input pulses are supplied by a generator having the following characteristics:
 t_r or $t_f \leq 6$ ns, pulse repetition rate (PRR) = 125 kHz, 50% duty cycle.

Copyright © 2016, Texas Instruments Incorporated

Figure 22. $t_{(loop)}$ Test Circuit and Voltage Waveforms

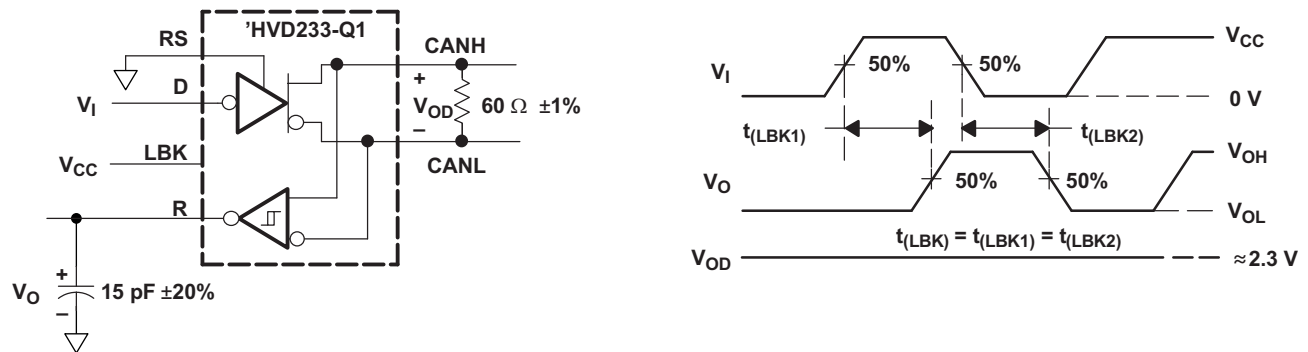

NOTE: All V_I input pulses are supplied by a generator having the following characteristics:
 t_r or $t_f \leq 6$ ns, pulse repetition rate (PRR) = 125 kHz, 50% duty cycle.

Copyright © 2016, Texas Instruments Incorporated

Figure 23. $t_{(LBK)}$ Test Circuit and Voltage Waveforms

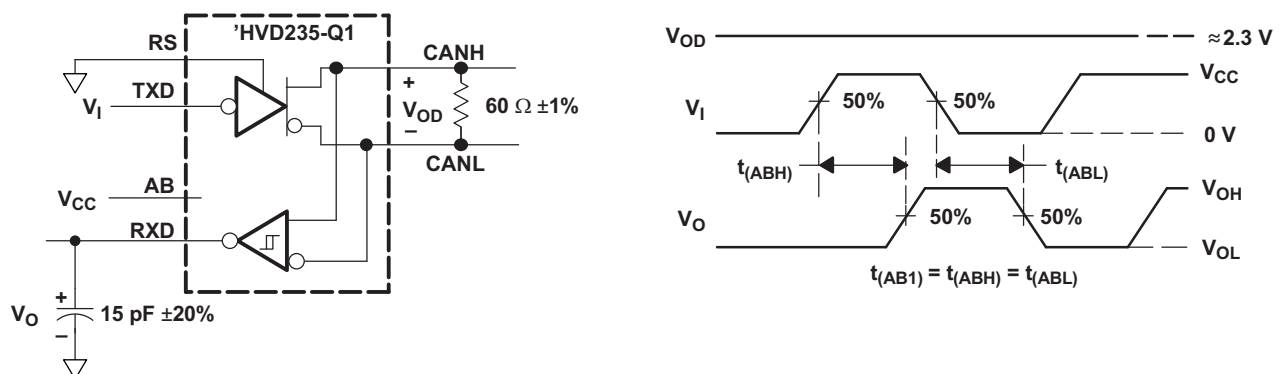

NOTE: All V_I input pulses are supplied by a generator having the following characteristics:
 t_r or $t_f \leq 6$ ns, pulse repetition rate (PRR) = 125 kHz, 50% duty cycle.

Copyright © 2016, Texas Instruments Incorporated

Figure 24. $t_{(AB1)}$ Test Circuit and Voltage Waveforms

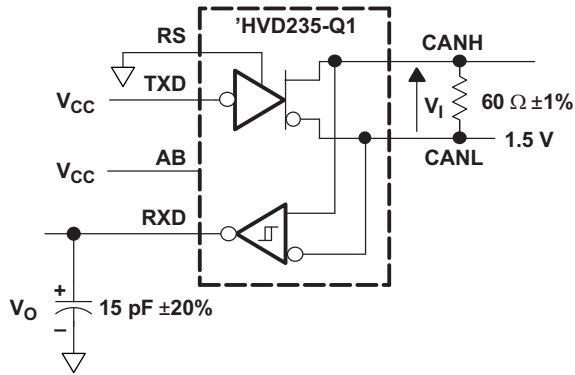

NOTE: All V_I input pulses are supplied by a generator having the following characteristics:
 t_r or $t_f \leq 6$ ns, pulse repetition rate (PRR) = 125 kHz, 50% duty cycle.

Copyright © 2016, Texas Instruments Incorporated

Figure 25. $t_{(AB2)}$ Test Circuit and Voltage Waveforms

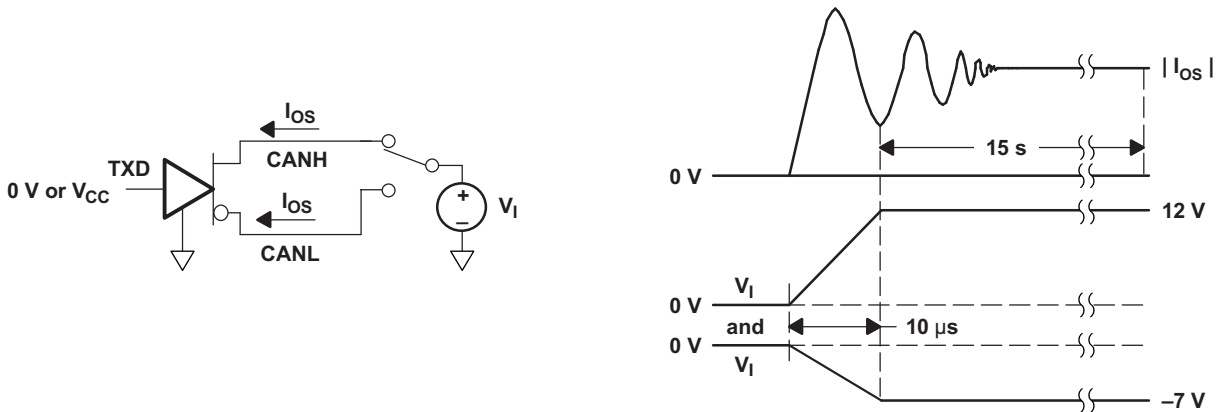
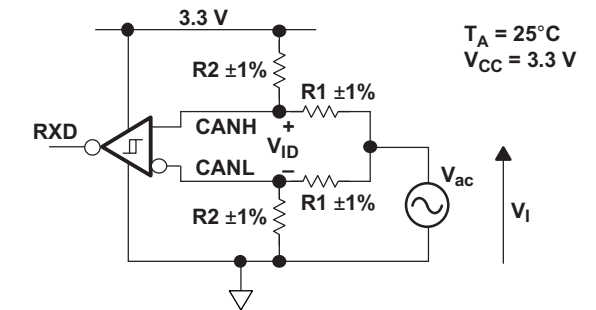

Figure 26. I_{OS} Test Circuit and Waveforms



The RXD Output State Does Not Change During Application of the Input Waveform.

V_{ID}	R1	R2
500 mV	50 Ω	280 Ω
900 mV	50 Ω	130 Ω



NOTE: All input pulses are supplied by a generator with $f \leq 1.5$ MHz.

Figure 27. Common-Mode Voltage Rejection

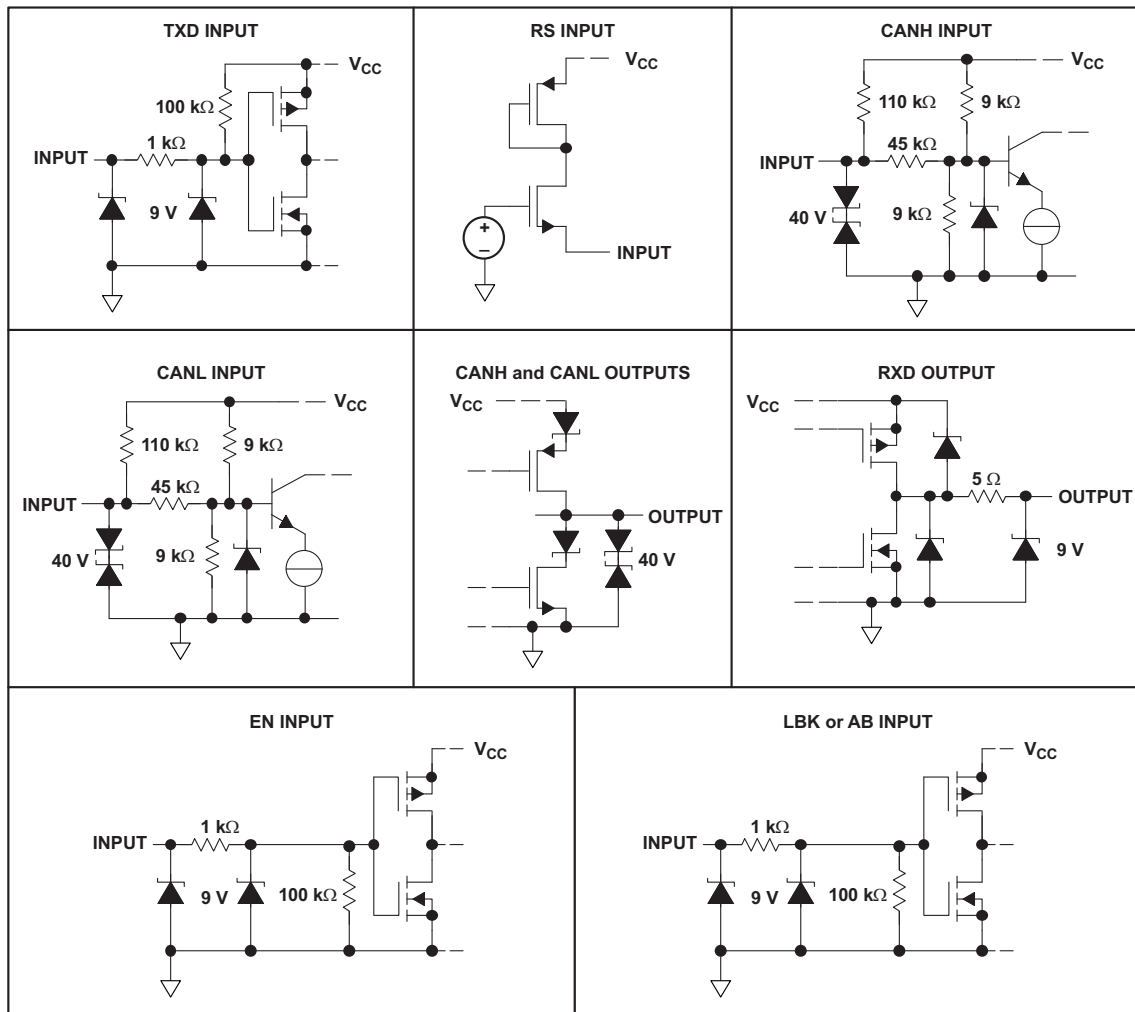

Figure 28. Equivalent Input and Output Schematic Diagrams

10 Detailed Description

10.1 Overview

This family of CAN transceivers is compatible with the ISO 11898-2 high-speed controller-area-network (CAN) physical layer standard. These devices are designed to interface between the differential bus lines in CAN and the CAN protocol controller at data rates up to 1 Mbps.

10.2 Functional Block Diagrams

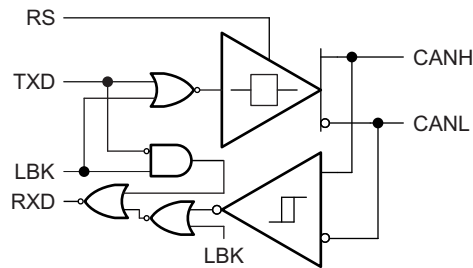

Figure 29. SN65HVD233-Q1 Functional Block Diagram

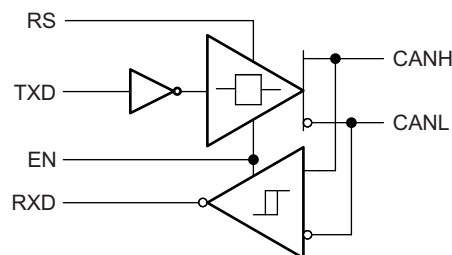

Figure 30. SN65HVD234-Q1 Functional Block Diagram

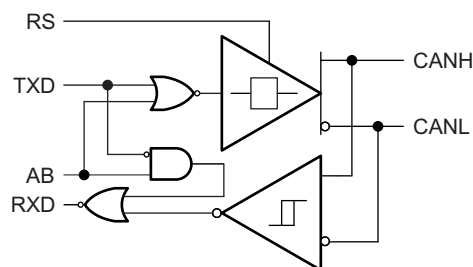

Figure 31. SN65HVD235-Q1 Functional Block Diagram

10.3 Feature Description

10.3.1 Diagnostic Loopback (SN65HVD233-Q1)

The diagnostic loopback or internal loopback function of the SN65HVD233-Q1 device is enabled with a high-level input on pin 5, LBK. This mode disables the driver output while keeping the bus pins biased to the recessive state. This mode also redirects the TXD data input (transmit data) through logic to the received data output pin, thus creating an internal loopback of the transmit-to-receive data path. This mimics the loopback that occurs normally with a CAN transceiver, because the receiver loops back the driven output to the RXD (receive data) pin. This mode allows the host protocol controller to input and read back a bit sequence or CAN messages to perform diagnostic routines without disturbing the CAN bus. A typical CAN bus application is displayed in [Figure 37](#).

Feature Description (continued)

If the LBK pin is not used, it may be tied to ground (GND). However, it is pulled low internally (defaults to a low-level input) and may be left open if not in use.

10.3.2 Autobaud Loopback (SN65HVD235-Q1)

The autobaud loopback mode of the SN65HVD235-Q1 device is enabled by placing a high-level input on pin 5, AB. In autobaud mode, the driver output is disabled, thus blocking the TXD pin-to-bus path and the bus transmit function of the transceiver. The bus pins remain biased to recessive. The receiver-to-RXD pin path of the device remains operational, allowing bus activity to be monitored. In addition, the autobaud mode includes an internal logic loopback path from the TXD pin to the RXD pin so the local node can transmit to itself in sync with bus traffic while not disturbing messages on the bus. Thus if the CAN controller of the local node generates an error frame, it is not transmitted to the bus, but is detected only by the local CAN controller. This is especially helpful to determine if the local node is set to the same baud rate as the network, and if not, to adjust it to the network baud rate (autobaud detection).

Autobaud detection is best suited to applications that have a known selection of baud rates. For example, if an application has optional settings of 125 kbps, 250 kbps, or 500 kbps. Once the SN65HVD235-Q1 device is placed into autobaud loopback mode, the application software could assume the first baud rate of 125 kbps. It then waits for a message to be transmitted by another node on the bus. If the wrong baud rate has been selected, an error message is generated by the local CAN controller because the sample times will not be at the correct time. However, because the bus-transmit function of the device has been disabled, no other nodes receive the error frame generated by the local CAN controller of this node.

The application would then make use of the status register indications of the local CAN controller for message-received and error-warning status to determine if the set baud rate is correct or not. The warning status indicates that the CAN controller error counters have been incremented. A message received status indicates that a good message has been received. If an error is generated, the application then sets the CAN controller to the next possibly valid baud rate, and waits to receive another message. This pattern is repeated until an error-free message has been received, thus the correct baud rate has been selected. At this point, the application places the SN65HVD235-Q1 device in a normal transmitting mode by setting pin 5 to a low level, thus enabling bus-transmit and bus-receive functions to normal operating states for the transceiver.

If the AB pin is not used, it may be tied to ground (GND). However, it is pulled low internally (defaults to a low-level input) and may be left open if not in use.

10.3.3 Slope Control

The rise and fall slope of the SN65HVD233-Q1, SN65HVD234-Q1, and SN65HVD235-Q1 driver output can be adjusted by connecting a resistor from RS (pin 8) to ground (GND) as shown in Figure 32, or to a low level input voltage as shown in Figure 33.

The slope of the driver output signal is proportional to the output current of the pin. This slope control is implemented with an external resistor value of 10 kΩ to achieve an approximately 15-V/μs slew rate, and up to 100 kΩ to achieve an approximately 2-V/μs slew rate. A typical slew-rate versus pulldown-resistance graph is shown in Figure 34. Typical driver output waveforms with slope control are displayed in Figure 40.

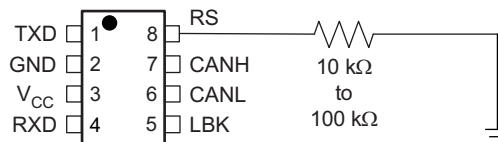

Figure 32. Ground Connection for Selecting Slope-Control or Standby Mode

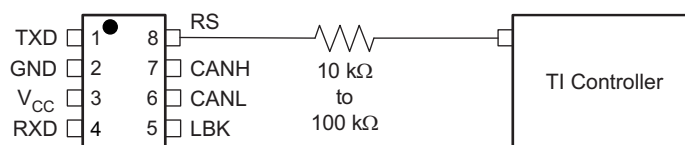

Figure 33. DSP Connection for Selecting Slope-Control or Standby Mode

Feature Description (continued)

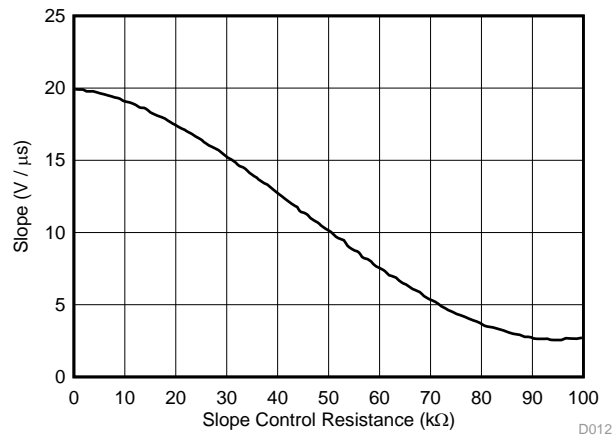

Figure 34. SN65HVD233-Q1 Driver Output-Signal Slope vs Slope-Control Resistance Value

10.3.4 Standby

If a high-level input ($> 0.75 V_{CC}$) is applied to RS (pin 8), the circuit enters a low-current, *listen only* standby mode during which the driver is switched off and the receiver remains active. If using this mode to save system power while waiting for bus traffic, the local controller can monitor the RXD output pin for a falling edge which indicates that a dominant signal was driven onto the CAN bus. The local controller can then drive the RS pin low to return to slope-control mode or high-speed mode.

10.3.5 Thermal Shutdown

If the junction temperature of the device exceeds the thermal shutdown threshold, the device turns off the CAN driver circuits, thus blocking the TXD pin-to-bus transmission path. The shutdown condition is cleared when the junction temperature drops sufficiently below the thermal shutdown temperature of the device. The CAN bus pins are high-impedance and biased to the recessive level during a thermal shutdown, and the receiver-to-RXD pin path remains operational.

10.4 Device Functional Modes

Table 2. Driver (SN65HVD233-Q1 or SN65HVD235-Q1)

INPUTS			OUTPUTS		
TXD	LBK or AB	RS	CANH	CANL	BUS STATE
X	X	$> 0.75 V_{CC}$	Z	Z	Recessive
L	L or open	$\leq 0.33 V_{CC}$	H	L	Dominant
H or open	X		Z	Z	Recessive
X	H	$\leq 0.33 V_{CC}$	Z	Z	Recessive

Table 3. Driver (SN65HVD234-Q1)

INPUTS			OUTPUTS		
TXD	EN	RS	CANH	CANL	BUS STATE
L	H	$\leq 0.33 V_{CC}$	H	L	Dominant
H	X	$\leq 0.33 V_{CC}$	Z	Z	Recessive
Open	X	X	Z	Z	Recessive
X	X	$> 0.75 V_{CC}$	Z	Z	Recessive
X	L or open	X	Z	Z	Recessive

Table 4. Receiver (SN65HVD233-Q1)⁽¹⁾

INPUTS				OUTPUT
BUS STATE	$V_{ID} = V_{(CANH)} - V_{(CANL)}$	LBK	TXD	RXD
Dominant	$V_{ID} \geq 0.9\text{ V}$	L or open	X	L
Recessive	$V_{ID} \leq 0.5\text{ V}$ or open	L or open	H or open	H
?	$0.5\text{ V} < V_{ID} < 0.9\text{ V}$	L or open	H or open	?
X	X	H	L	L
X	X	H	H	H

(1) H = high level; L = low level; Z = high impedance; X = irrelevant; ? = indeterminate

Table 5. Receiver (SN65HVD235-Q1)⁽¹⁾

INPUTS				OUTPUT
BUS STATE	$V_{ID} = V_{(CANH)} - V_{(CANL)}$	AB	TXD	RXD
Dominant	$V_{ID} \geq 0.9\text{ V}$	L or open	X	L
Recessive	$V_{ID} \leq 0.5\text{ V}$ or open	L or open	H or open	H
?	$0.5\text{ V} < V_{ID} < 0.9\text{ V}$	L or open	H or open	?
Dominant	$V_{ID} \geq 0.9\text{ V}$	H	X	L
Recessive	$V_{ID} \leq 0.5\text{ V}$ or open	H	H	H
Recessive	$V_{ID} \leq 0.5\text{ V}$ or open	H	L	L
?	$0.5\text{ V} < V_{ID} < 0.9\text{ V}$	H	L	L

(1) H = high level; L = low level; Z = high impedance; X = irrelevant; ? = indeterminate

Table 6. Receiver (SN65HVD234-Q1)⁽¹⁾

INPUTS			OUTPUT
BUS STATE	$V_{ID} = V_{(CANH)} - V_{(CANL)}$	EN	RXD
Dominant	$V_{ID} \geq 0.9\text{ V}$	H	L
Recessive	$V_{ID} \leq 0.5\text{ V}$ or open	H	H
?	$0.5\text{ V} < V_{ID} < 0.9\text{ V}$	H	?
X	X	L or open	H

(1) H = high level; L = low level; Z = high impedance; X = irrelevant; ? = indeterminate

11 Application and Implementation

NOTE

Information in the following applications sections is not part of the TI component specification, and TI does not warrant its accuracy or completeness. TI's customers are responsible for determining suitability of components for their purposes. Customers should validate and test their design implementation to confirm system functionality.

11.1 Application Information

The CAN bus has two states during powered operation of the device, *dominant* and *recessive*. A dominant bus state is when the bus is driven differentially, corresponding to a logic low on the TXD and RXD pins. A recessive bus state is when the bus is biased to $V_{CC} / 2$ via the high-resistance internal resistors R_{IN} and R_{ID} of the receiver, corresponding to a logic high on the TXD and RXD pins. See [Figure 35](#) and [Figure 36](#).

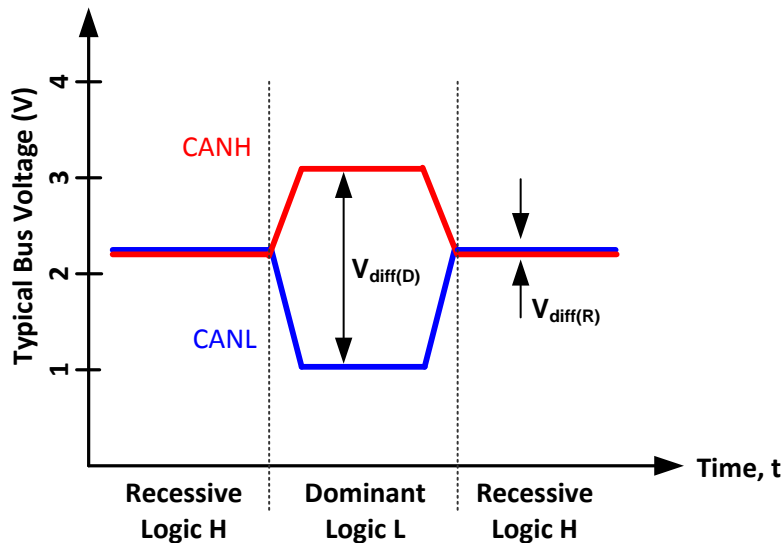

Figure 35. Bus States (Physical Bit Representation)

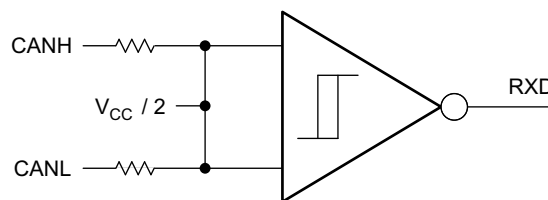
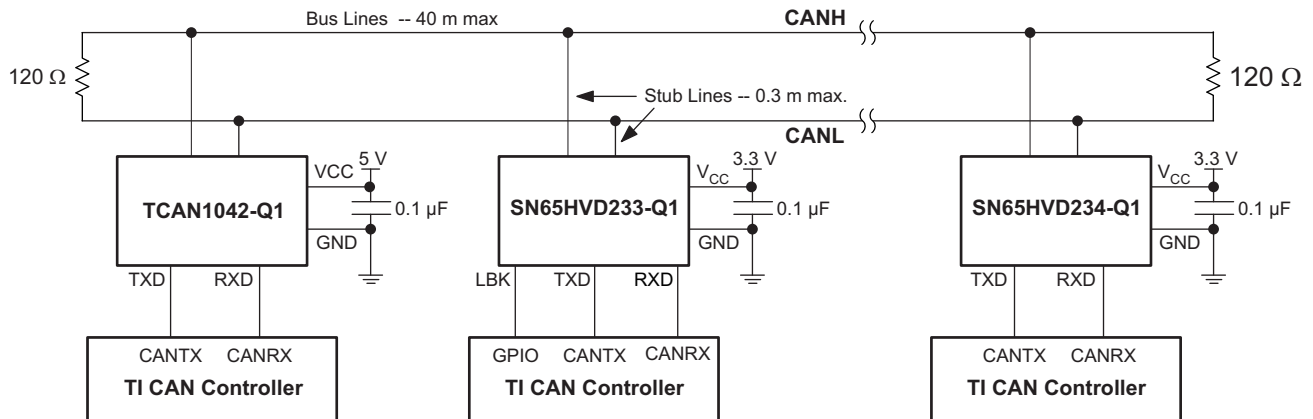

Figure 36. Simplified Recessive Common-Mode Bias and Receiver

These CAN transceivers are typically used in applications with a host microprocessor or FPGA that includes the link layer portion of the CAN protocol. The different nodes on the network are typically connected through the use of a 120- Ω characteristic impedance twisted-pair cable with termination on both ends of the bus.

11.2 Typical Application



Copyright © 2016, Texas Instruments Incorporated

Figure 37. Typical SN65HVD233-Q1 Application

11.2.1 Design Requirements

11.2.1.1 Bus Loading, Length and Number of Nodes

The ISO 11898 standard specifies a data rate of up to 1 Mbps, maximum CAN bus cable length of 40 m, maximum drop line (stub) length of 0.3 m and a maximum of 30 nodes. However, with careful network design, the system may have longer cables, longer stub lengths, and many more nodes to a bus. Many CAN organizations and standards have scaled the use of CAN for applications outside the original ISO 11898 standard. They have made system-level trade-offs for data rate, cable length, and parasitic loading of the bus. Examples of some of these specifications are ARINC825, CANopen, CAN Kingdom, DeviceNet and NMEA200.

A high number of nodes requires a transceiver with high input impedance and wide common-mode range, such as the SN65HVD23x-Q1 CAN family. ISO 11898-2 specifies the driver differential output with a 60-Ω load (two 120-Ω termination resistors in parallel) and the differential output must be greater than 1.5 V. The SN65HVD23x-Q1 devices are specified to meet the 1.5-V requirement with a 60-Ω load, and additionally specified with a differential output voltage minimum of 1.2 V across a common mode range of –2 V to 7 V through a 330-Ω coupling network. This network represents the bus loading of 120 SN65HVD23x-Q1 transceivers based on their minimum differential input resistance of 40 kΩ. Therefore, the SN65HVD23x-Q1 devices support up to 120 transceivers on a single bus segment with margin to the 1.2-V minimum differential input-voltage requirement at each node.

For CAN network design, margin must be given for signal loss across the system and cabling, parasitic loadings, network imbalances, ground offsets and signal integrity. Thus, a practical maximum number of nodes may be lower. Bus length may also be extended beyond the original ISO 11898 standard of 40 m by careful system-design and data-rate tradeoffs. For example, CANopen network design guidelines allow the network to be up to 1 km with changes in the termination resistance, cabling, fewer than 64 nodes, and significantly lowered data rate.

This flexibility in CAN network design is one of the key strengths of the various extensions and additional standards that have been built on the original ISO 11898 CAN standard.

11.2.1.2 CAN Termination

The ISO 11898 standard specifies the interconnect to be a twisted-pair cable (shielded or unshielded) with 120-Ω characteristic impedance (Z_0). Resistors equal to the characteristic impedance of the line should be used to terminate both ends of the cable to prevent signal reflections. Unterminated drop lines (stubs) connecting nodes to the bus should be kept as short as possible to minimize signal reflections. The termination may be on the cable or in a node, but if nodes may be removed from the bus the termination must be carefully placed so that it is not removed from the bus.

Typical Application (continued)

11.2.2 Detailed Design Procedure

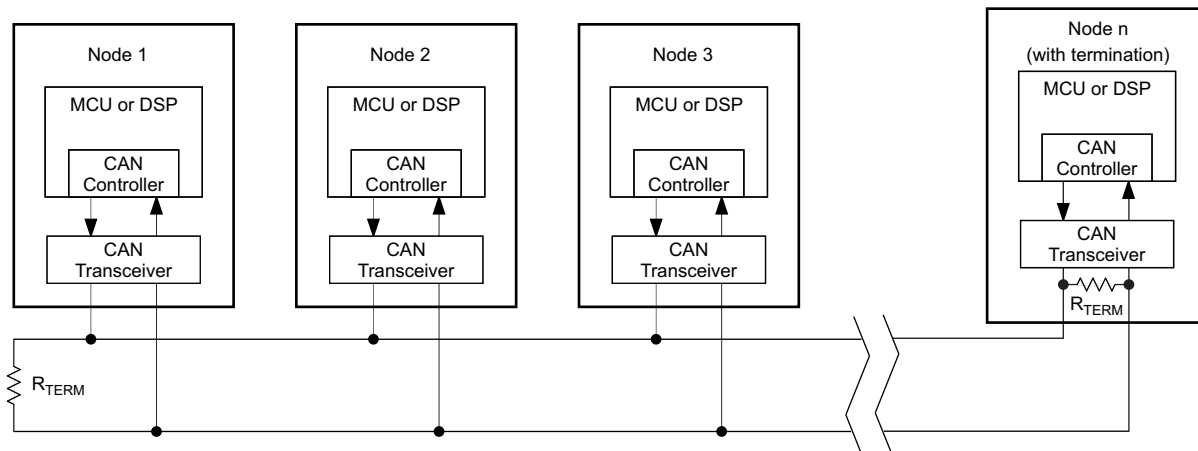

Figure 38. Typical CAN Bus

Termination is typically a 120- Ω resistor at each end of the bus. If filtering and stabilization of the common-mode voltage of the bus is desired, then split termination may be used (see [Figure 39](#)). Split termination uses two 60- Ω resistors with a capacitor in the middle of these resistors to ground. Split termination improves the electromagnetic emissions behavior of the network by eliminating fluctuations in the bus common-mode voltages at the start and end of message transmissions.

Care should be taken in the power ratings of the termination resistors used. Typically, the worst-case condition would be if the system power supply is shorted across the termination resistance to ground. In most cases, the current flow through the resistor in this condition would be much higher than the transceiver current limit.

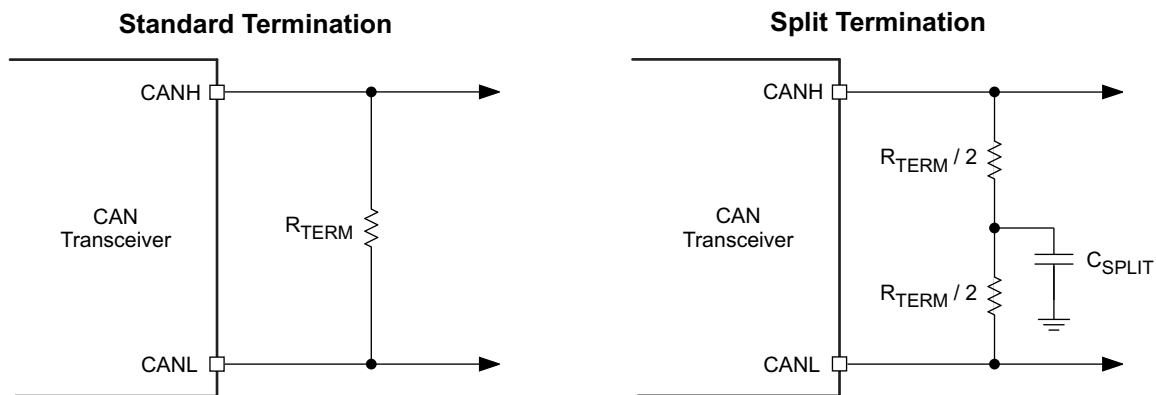

Figure 39. CAN Bus Termination Concepts

11.2.3 Application Curve

[Figure 40](#) shows three typical output waveforms for the SN65HVD233-Q1 device with three different connections made to the RS pin. The top waveform shows the typical differential signal when transitioning from a recessive level to a dominant level on the CAN bus with RS tied to GND through a 0- Ω resistor. The second waveform shows the same signal for the condition with a 10-k Ω resistor tied from RS to ground. The bottom waveform shows the typical differential signal for the case where a 100-k Ω resistor is tied from the RS pin to ground.

Typical Application (continued)

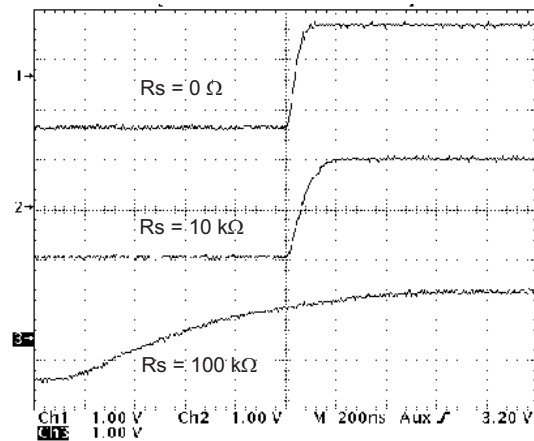

Figure 40. Typical SN65HVD233-Q1 Output Waveforms With Different Slope-Control Resistor Values

11.3 System Example

11.3.1 ISO 11898 Compliance of SN65HVD23x-Q1 Family of 3.3-V CAN Transceivers

11.3.1.1 Introduction

Many users value the low power consumption of operating their CAN transceivers from a 3.3-V supply. However, some are concerned about the interoperability with 5-V-supplied transceivers on the same bus. This report analyzes this situation to address those concerns.

11.3.1.2 Differential Signal

CAN is a differential bus where complementary signals are sent over two wires and the voltage difference between the two wires defines the logical state of the bus. The differential CAN receiver monitors this voltage difference and outputs the bus state with a single-ended logic-level output signal.

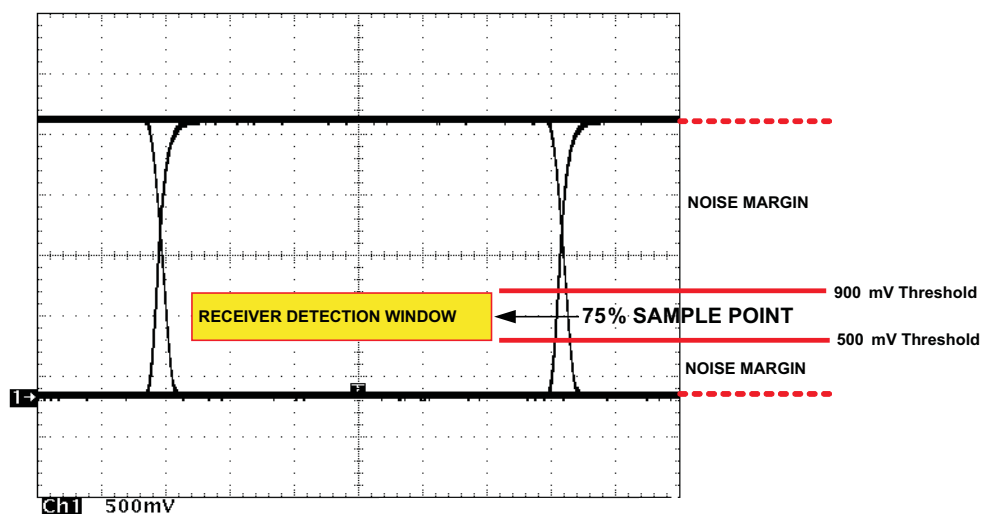

Figure 41. Typical Differential-Output-Voltage Waveform

System Example (continued)

The CAN driver creates the differential voltage between CANH and CANL in the dominant state. The dominant differential output of the SN65HVD23x-Q1 device is greater than 1.5 V and less than 3 V across a 60- Ω load as defined by the ISO 11898 standard. These are the same limiting values as for 5-V-supplied CAN transceivers. The bus termination resistors, and not the CAN driver, drive the bus to the recessive state.

A CAN receiver is required to output a recessive state when less than 500 mV of differential voltage exists on the bus, and a dominant state when more than 900 mV of differential voltage exists on the bus. The CAN receiver must do this with common-mode input voltages from -2 V to 7 V. The SN65HVD23x-Q1 family of receivers meets these same input specifications as 5-V-supplied receivers do.

11.3.1.3 Common-Mode Signal

The differential receiver rejects the common-mode signal, which is the average of the two CAN signals. The common-mode signal comes from the CAN driver, ground noise, and coupled bus noise. Because the bias voltage of the recessive state of the device is dependent on V_{CC} , any noise present or any variation of V_{CC} has an effect on this bias voltage seen by the bus. The SN65HVD23x-Q1 family has the recessive bias voltage set higher than $0.5 \times V_{CC}$ to comply with the ISO 11898-2 CAN standard. The caveat to this is that the common-mode voltage drops by a approximately 200 millivolts when driving a dominant bit on the bus. This means that there is a common-mode shift between the dominant-bit and recessive-bit states of the device. Although this is not ideal, this small variation in the driver common-mode output is rejected by differential receivers and does not affect data, signal noise margins, or error rates.

11.3.1.4 Interoperability of 3.3-V CAN in 5-V CAN Systems

The 3.3-V-supplied SN65HVD23x-Q1 family of CAN transceivers is fully compatible with 5-V CAN transceivers. The differential output voltage is the same, the recessive common-mode output bias is the same, and the receivers have the same input specifications. The only slight difference is in the dominant common-mode output voltage, which is approximately 200 millivolts lower for a 3.3-V CAN transceiver than for a 5-V-supplied transceiver.

To help ensure the widest interoperability possible, the SN65HVD23x-Q1 family has successfully passed the internationally recognized GIFT/ICT conformance and interoperability testing for CAN transceivers. Electrical interoperability does not always assure interchangeability, however. Most implementers of CAN buses recognize that ISO 11898 does not sufficiently specify the electrical layer and that strict standard compliance alone does not ensure full interchangeability. This comes only with thorough equipment testing.

12 Power Supply Recommendations

To ensure reliable operation at all data rates and supply voltages, each supply should be decoupled with a 100-nF ceramic capacitor located as close to the V_{CC} supply pins as possible. The TPS76333-Q1 is a linear voltage regulator suitable for the 3.3 V supply.

13 Layout

13.1 Layout Guidelines

In order for the PCB design to be successful, start with design of the protection and filtering circuitry. Because ESD and EFT transients have a wide frequency bandwidth from approximately 3 MHz to 3 GHz, high-frequency layout techniques must be applied during PCB design. On-chip IEC ESD protection is good for laboratory and portable equipment but is usually not sufficient for EFT and surge transients occurring in industrial environments. Therefore, robust and reliable bus node design requires the use of external transient protection devices at the bus connectors. Placement at the connector also prevents these harsh transient events from propagating further into the PCB and system.

Use V_{CC} and ground planes to provide low inductance.

Layout Guidelines (continued)

NOTE

High-frequency current follows the path of least inductance and not the path of least resistance.

Design bus protection by placing the protective components in the signal path. Do not force the transient current to divert from the signal path to reach the protection device.

An example placement of the transient-voltage-suppression (TVS) device indicated as D1 (either bidirectional diode or varistor solution) and bus filter capacitors C8 and C9 is shown in [Figure 42](#).

The bus transient protection and filtering components should be placed as close to the bus connector, J1, as possible. This prevents transients, ESD and noise from penetrating onto the board and disturbing other devices.

Bus termination: [Figure 42](#) shows split termination. This is where the termination is split into two resistors, R5 and R6, with the center or split tap of the termination connected to ground via capacitor C7. Split termination provides common-mode filtering for the bus. When termination is placed on the board instead of directly on the bus, care must be taken to ensure the terminating node is not removed from the bus, as there are signal integrity issues if the bus is not properly terminated on both ends. See the [Detailed Design Procedure](#) section for information on power ratings needed for the termination resistor(s).

Bypass and bulk capacitors should be placed as close as possible to the supply pins of the transceiver, as in the example of C2 and C3 on V_{CC} .

Use at least two vias for the V_{CC} and ground connections of the bypass capacitors and protection devices to minimize trace and via inductance.

To limit current on the digital lines, serial resistors may be used. Examples are R1, R2, R3 and R4.

To filter noise on the digital I/O lines, a capacitor may be used close to the input side of the I/O as shown by C1 and C4.

Because the internal pullup and pulldown biasing of the device is weak for floating pins, an external 1-k Ω to 10-k Ω pullup or pulldown resistor should be used to bias the state of the pin more strongly against noise during transient events.

Pin 1: If an open-drain host processor is used to drive the TXD pin of the device, an external pullup resistor between 1 k Ω and 10 k Ω to V_{CC} should be used to drive the recessive input state of the device.

Pin 8: The mode pin, RS, is shown, assuming that it is used in the application. If the device is only to be used in normal mode or slope-control mode, R3 is not needed and the pads of C4 could be used for the pulldown resistor to GND.

13.2 Layout Example

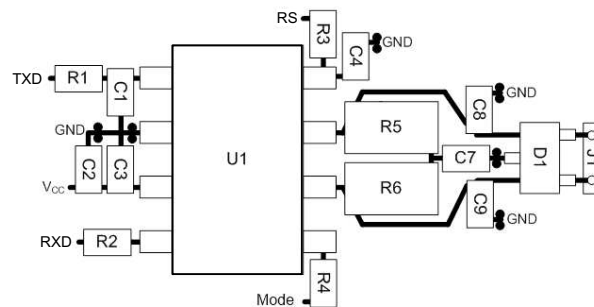

Figure 42. Layout Example Diagram

14 器件和文档支持

14.1 相关链接

以下表格列出了快速访问链接。范围包括技术文档、支持与社区资源、工具和软件，并且可以快速访问样片或购买链接。

表 7. 相关链接

器件	产品文件夹	样片与购买	技术文档	工具与软件	支持与社区
SN65HVD233-Q1	请单击此处	请单击此处	请单击此处	请单击此处	请单击此处
SN65HVD234-Q1	请单击此处	请单击此处	请单击此处	请单击此处	请单击此处
SN65HVD235-Q1	请单击此处	请单击此处	请单击此处	请单击此处	请单击此处

14.2 接收文档更新通知

如需接收文档更新通知，请访问 ti.com 上的器件产品文件夹。点击右上角的 **提醒我 (Alert me)** 注册后，即可每周定期收到已更改的产品信息。有关更改的详细信息，请查阅已修订文档中包含的修订历史记录。

14.3 社区资源

The following links connect to TI community resources. Linked contents are provided "AS IS" by the respective contributors. They do not constitute TI specifications and do not necessarily reflect TI's views; see TI's [Terms of Use](#).

TI E2E™ Online Community *TI's Engineer-to-Engineer (E2E) Community*. Created to foster collaboration among engineers. At e2e.ti.com, you can ask questions, share knowledge, explore ideas and help solve problems with fellow engineers.

Design Support *TI's Design Support* Quickly find helpful E2E forums along with design support tools and contact information for technical support.

14.4 商标

E2E is a trademark of Texas Instruments.
All other trademarks are the property of their respective owners.

14.5 静电放电警告



这些装置包含有限的内置 ESD 保护。存储或装卸时，应将导线一起截短或将装置放置于导电泡棉中，以防止 MOS 门极遭受静电损伤。

14.6 Glossary

SLYZ022 — *TI Glossary*.

This glossary lists and explains terms, acronyms, and definitions.

15 机械、封装和可订购信息

以下页中包括机械、封装和可订购信息。这些信息是针对指定器件可提供的最新数据。本数据随时可能发生变更并且不对本文档进行修订，恕不另行通知。要获得这份数据表的浏览器版本，请查阅左侧的导航窗格。

PACKAGING INFORMATION

Orderable Device	Status (1)	Package Type	Package Drawing	Pins	Package Qty	Eco Plan (2)	Lead finish/ Ball material (6)	MSL Peak Temp (3)	Op Temp (°C)	Device Marking (4/5)	Samples
SN65HVD233QDRQ1	ACTIVE	SOIC	D	8	2500	RoHS & Green	NIPDAU	Level-1-260C-UNLIM	-40 to 125	233Q	Samples
SN65HVD234QDRQ1	ACTIVE	SOIC	D	8	2500	RoHS & Green	NIPDAU	Level-1-260C-UNLIM	-40 to 125	234Q	Samples
SN65HVD235QDRQ1	ACTIVE	SOIC	D	8	2500	RoHS & Green	NIPDAU	Level-1-260C-UNLIM	-40 to 125	235Q	Samples

(1) The marketing status values are defined as follows:

ACTIVE: Product device recommended for new designs.

LIFEBUY: TI has announced that the device will be discontinued, and a lifetime-buy period is in effect.

NRND: Not recommended for new designs. Device is in production to support existing customers, but TI does not recommend using this part in a new design.

PREVIEW: Device has been announced but is not in production. Samples may or may not be available.

OBSOLETE: TI has discontinued the production of the device.

(2) **RoHS:** TI defines "RoHS" to mean semiconductor products that are compliant with the current EU RoHS requirements for all 10 RoHS substances, including the requirement that RoHS substance do not exceed 0.1% by weight in homogeneous materials. Where designed to be soldered at high temperatures, "RoHS" products are suitable for use in specified lead-free processes. TI may reference these types of products as "Pb-Free".

RoHS Exempt: TI defines "RoHS Exempt" to mean products that contain lead but are compliant with EU RoHS pursuant to a specific EU RoHS exemption.

Green: TI defines "Green" to mean the content of Chlorine (Cl) and Bromine (Br) based flame retardants meet JS709B low halogen requirements of <=1000ppm threshold. Antimony trioxide based flame retardants must also meet the <=1000ppm threshold requirement.

(3) MSL, Peak Temp. - The Moisture Sensitivity Level rating according to the JEDEC industry standard classifications, and peak solder temperature.

(4) There may be additional marking, which relates to the logo, the lot trace code information, or the environmental category on the device.

(5) Multiple Device Markings will be inside parentheses. Only one Device Marking contained in parentheses and separated by a "~" will appear on a device. If a line is indented then it is a continuation of the previous line and the two combined represent the entire Device Marking for that device.

(6) Lead finish/Ball material - Orderable Devices may have multiple material finish options. Finish options are separated by a vertical ruled line. Lead finish/Ball material values may wrap to two lines if the finish value exceeds the maximum column width.

Important Information and Disclaimer:The information provided on this page represents TI's knowledge and belief as of the date that it is provided. TI bases its knowledge and belief on information provided by third parties, and makes no representation or warranty as to the accuracy of such information. Efforts are underway to better integrate information from third parties. TI has taken and continues to take reasonable steps to provide representative and accurate information but may not have conducted destructive testing or chemical analysis on incoming materials and chemicals. TI and TI suppliers consider certain information to be proprietary, and thus CAS numbers and other limited information may not be available for release.

In no event shall TI's liability arising out of such information exceed the total purchase price of the TI part(s) at issue in this document sold by TI to Customer on an annual basis.

TAPE AND REEL INFORMATION

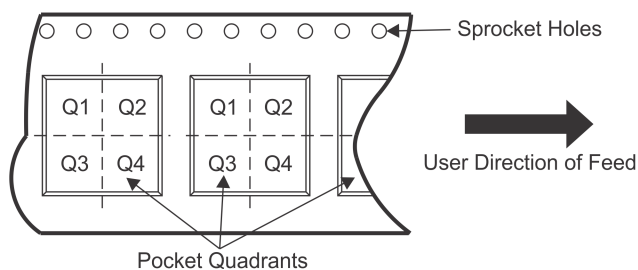
QUADRANT ASSIGNMENTS FOR PIN 1 ORIENTATION IN TAPE

*All dimensions are nominal

Device	Package Type	Package Drawing	Pins	SPQ	Reel Diameter (mm)	Reel Width W1 (mm)	A0 (mm)	B0 (mm)	K0 (mm)	P1 (mm)	W (mm)	Pin1 Quadrant
SN65HVD233QDRQ1	SOIC	D	8	2500	330.0	12.4	6.4	5.2	2.1	8.0	12.0	Q1
SN65HVD234QDRQ1	SOIC	D	8	2500	330.0	12.4	6.4	5.2	2.1	8.0	12.0	Q1
SN65HVD235QDRQ1	SOIC	D	8	2500	330.0	12.4	6.4	5.2	2.1	8.0	12.0	Q1

TAPE AND REEL BOX DIMENSIONS

*All dimensions are nominal

Device	Package Type	Package Drawing	Pins	SPQ	Length (mm)	Width (mm)	Height (mm)
SN65HVD233QDRQ1	SOIC	D	8	2500	340.5	336.1	25.0
SN65HVD234QDRQ1	SOIC	D	8	2500	340.5	336.1	25.0
SN65HVD235QDRQ1	SOIC	D	8	2500	340.5	336.1	25.0



D0008A

PACKAGE OUTLINE

SOIC - 1.75 mm max height

SMALL OUTLINE INTEGRATED CIRCUIT



4214825/C 02/2019

NOTES:

- Linear dimensions are in inches [millimeters]. Dimensions in parenthesis are for reference only. Controlling dimensions are in inches. Dimensioning and tolerancing per ASME Y14.5M.
- This drawing is subject to change without notice.
- This dimension does not include mold flash, protrusions, or gate burrs. Mold flash, protrusions, or gate burrs shall not exceed $.006$ [0.15] per side.
- This dimension does not include interlead flash.
- Reference JEDEC registration MS-012, variation AA.

EXAMPLE BOARD LAYOUT

D0008A

SOIC - 1.75 mm max height

SMALL OUTLINE INTEGRATED CIRCUIT



LAND PATTERN EXAMPLE
 EXPOSED METAL SHOWN
 SCALE:8X



SOLDER MASK DETAILS

4214825/C 02/2019

NOTES: (continued)

6. Publication IPC-7351 may have alternate designs.

7. Solder mask tolerances between and around signal pads can vary based on board fabrication site.

EXAMPLE STENCIL DESIGN

D0008A

SOIC - 1.75 mm max height

SMALL OUTLINE INTEGRATED CIRCUIT



SOLDER PASTE EXAMPLE
BASED ON .005 INCH [0.125 MM] THICK STENCIL
SCALE:8X

4214825/C 02/2019

NOTES: (continued)

8. Laser cutting apertures with trapezoidal walls and rounded corners may offer better paste release. IPC-7525 may have alternate design recommendations.
9. Board assembly site may have different recommendations for stencil design.

重要声明和免责声明

TI 提供技术和可靠性数据（包括数据表）、设计资源（包括参考设计）、应用或其他设计建议、网络工具、安全信息和其他资源，不保证没有瑕疵且不做任何明示或暗示的担保，包括但不限于对适销性、某特定用途方面的适用性或不侵犯任何第三方知识产权的暗示担保。

这些资源可供使用 TI 产品进行设计的熟练开发人员使用。您将自行承担以下全部责任：(1) 针对您的应用选择合适的 TI 产品，(2) 设计、验证并测试您的应用，(3) 确保您的应用满足相应标准以及任何其他安全、安保或其他要求。这些资源如有变更，恕不另行通知。TI 授权您仅可将这些资源用于研发本资源所述的 TI 产品的应用。严禁对这些资源进行其他复制或展示。您无权使用任何其他 TI 知识产权或任何第三方知识产权。您应全额赔偿因在这些资源的使用中对 TI 及其代表造成的任何索赔、损害、成本、损失和债务，TI 对此概不负责。

TI 提供的产品受 TI 的销售条款 (<https://www.ti.com.cn/zh-cn/legal/termsofsale.html>) 或 [ti.com.cn](https://www.ti.com.cn) 上其他适用条款/TI 产品随附的其他适用条款的约束。TI 提供这些资源并不会扩展或以其他方式更改 TI 针对 TI 产品发布的适用的担保或担保免责声明。

邮寄地址：上海市浦东新区世纪大道 1568 号中建大厦 32 楼，邮政编码：200122

Copyright © 2021 德州仪器半导体技术（上海）有限公司