

AMC1305x-Q1

高精度、增强隔离式 Δ - Σ 调制器

1 特性

- 汽车电子 应用认证
- 具有符合 AEC-Q100 的下列结果：
 - 温度等级 1: -40°C 至 $+125^{\circ}\text{C}$
 - 人体放电模式 (HBM) 静电放电 (ESD) 分类等级 2
 - 组件充电模式 (CDM) ESD 分类等级 C6
- 与以下器件引脚兼容的系列：
 - 输入电压范围为 $\pm 50\text{mV}$ 或 $\pm 250\text{mV}$
 - 互补金属氧化物半导体 (CMOS) 或低压差分信号 (LVDS) 数字接口选项
- 出色的直流性能：
 - 偏移误差: $\pm 50\mu\text{V}$ 或 $\pm 150\mu\text{V}$ (最大值)
 - 偏移漂移: $1.3\mu\text{V}/^{\circ}\text{C}$ (最大值)
 - 增益误差: $\pm 0.3\%$ (最大值)
 - 增益漂移: $\pm 40\text{ppm}/^{\circ}\text{C}$ (最大值)
- 安全相关认证：
 - 7000 V_{PK} 增强型隔离, 符合 DIN V VDE V 0884-10 (VDE V 0884-10): 2006-12 标准
 - 符合 UL 1577 标准且长达 1 分钟的 5000 V_{RMS} 隔离
 - CAN/CSA No. 5A 组件验收服务通知
- 瞬态抗扰度: $15\text{kV}/\mu\text{s}$ (最小值)
- 高电磁场抗扰度 (请参见应用手册 [SLLA181A](#))
- 5MHz 至 20MHz 外部时钟输入

2 应用

- 基于分流的电流感测或基于电阻分压器的电压感测输入：
 - 牵引逆变器
 - 板载充电器 (OBC)
 - 直流-直流转换器
 - 电池管理系统 (BMS)

3 说明

AMC1305-Q1 器件是一款高精度 Δ - Σ ($\Delta\Sigma$) 调制器, 通过磁场抗扰度较高的电容式双隔离栅隔离输出与输入电路。根据 DIN V VDE V 0884-10、UL1577 和 CSA 标准, 该隔离栅经认证可提供高达 7000 V_{峰值} 的增强型隔离。当与隔离电源配合使用时, 该器件可防止共模高电压线路上的噪声电流进入本地系统接地, 从而干扰或损害低电压电路。

AMC1305-Q1 针对直接连接分流电阻器或其它低电压等级信号源进行了优化, 同时具有出色的直流和交流性能。分流电阻通常用于感测牵引逆变器、车载充电器或类似汽车应用中的电流。通过使用适当的数字滤波器 (即, 集成于 [TMS320F2837x](#)) 来抽取位流, 该器件可在 78kSPS 数据速率下实现 85dB (13.8 ENOB) 动态范围的 16 位分辨率。

在高侧, 调制器由 5V (AVDD) 标称电压供电, 而隔离数字接口则由 3.3V 或 5V 电源 (DVDD) 供电。

AMC1305-Q1 采用宽体小外形尺寸集成电路 (SOIC)-16 (DW) 封装。

器件信息⁽¹⁾

器件型号	封装	封装尺寸 (标称值)
AMC1305x-Q1	SOIC (16)	10.30mm x 7.50mm

(1) 如需了解所有可用封装, 请参见数据表末尾的可订购产品附录。

简化电路原理图

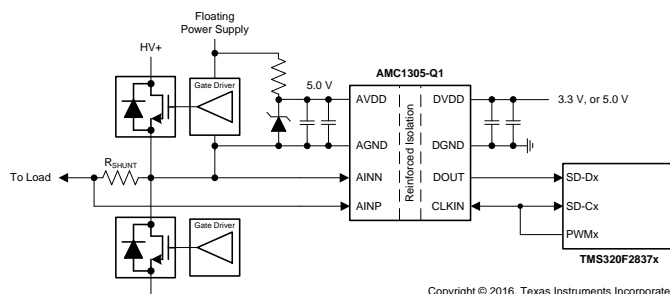

Copyright © 2016, Texas Instruments Incorporated



目录

1	特性	1	8.1	Overview	20
2	应用	1	8.2	Functional Block Diagram	20
3	说明	1	8.3	Feature Description	21
4	修订历史记录	2	8.4	Device Functional Modes	23
5	Device Comparison Table	3	9	Application and Implementation	24
6	Pin Configuration and Functions	3	9.1	Application Information	24
7	Specifications	4	9.2	Typical Applications	25
7.1	Absolute Maximum Ratings	4	10	Power-Supply Recommendations	29
7.2	ESD Ratings	4	11	Layout	30
7.3	Recommended Operating Conditions	4	11.1	Layout Guidelines	30
7.4	Thermal Information	4	11.2	Layout Examples	30
7.5	Power Ratings	4	12	器件和文档支持	32
7.6	Insulation Specifications	5	12.1	文档支持	32
7.7	Safety-Related Certifications	6	12.2	相关链接	32
7.8	Safety Limiting Values	6	12.3	接收文档更新通知	32
7.9	Electrical Characteristics: AMC1305M05-Q1	7	12.4	社区资源	32
7.10	Electrical Characteristics: AMC1305x25-Q1	9	12.5	商标	32
7.11	Switching Characteristics	11	12.6	静电放电警告	32
7.12	Insulation Characteristics Curves	12	12.7	Glossary	32
7.13	Typical Characteristics	13	13	机械、封装和可订购信息	33
8	Detailed Description	20			

4 修订历史记录

日期	修订版本	注释
2017 年2 月	*	首次发布。

5 Device Comparison Table

PART NUMBER	INPUT VOLTAGE RANGE	DIFFERENTIAL INPUT RESISTANCE	SNR (sinc ³ Filter, 78 kSPS)	OUTPUT INTERFACE
AMC1305L25-Q1	±250 mV	25 kΩ	82 dB	LVDS
AMC1305M05-Q1	±50 mV	5 kΩ	76 dB	CMOS
AMC1305M25-Q1	±250 mV	25 kΩ	82 dB	CMOS

6 Pin Configuration and Functions

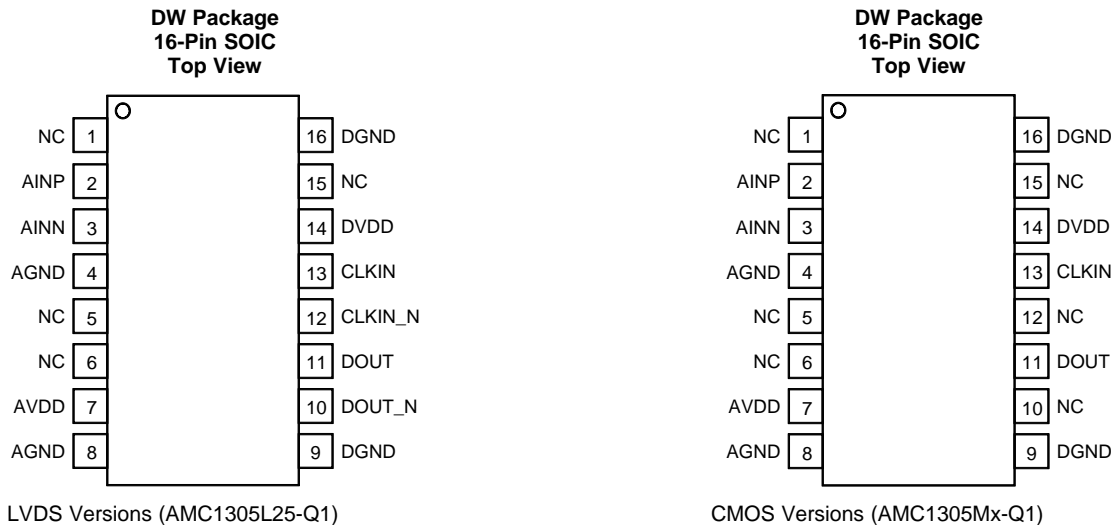

Pin Functions

PIN		I/O	DESCRIPTION
NAME	NO.		
AGND	4	—	This pin is internally connected to pin 8 and can be left unconnected or tied to high-side ground
	8	—	High-side ground reference
AINN	3	I	Inverting analog input
AINP	2	I	Noninverting analog input
AVDD	7	—	High-side power supply, 4.5 V to 5.5 V. See the Power-Supply Recommendations section for decoupling recommendations.
CLKIN	13	I	Modulator clock input, 5 MHz to 20.1 MHz
CLKIN_N	12	I	AMC1305L25-Q1 only: inverted modulator clock input
DGND	9, 16	—	Controller-side ground reference
DOUT	11	O	Modulator data output
DOUT_N	10	O	AMC1305L25-Q1 only: inverted modulator data output
DVDD	14	—	Controller-side power supply, 3.0 to 5.5 V
NC	1	—	This pin can be connected to AVDD or can be left unconnected
	5	—	This pin can be left unconnected or tied to AGND only
	6, 10, 12	—	These pins have no internal connection (pins 10 and 12 on the AMC1305Mx-Q1 only).
	15	—	This pin can be left unconnected or tied to DVDD only

7 Specifications

7.1 Absolute Maximum Ratings

over the operating ambient temperature range (unless otherwise noted)⁽¹⁾

	MIN	MAX	UNIT
Supply voltage, AVDD to AGND or DVDD to DGND	-0.3	6.5	V
Analog input voltage at AINP, AINN	AGND – 6	AVDD + 0.5	V
Digital input voltage at CLKIN, CLKIN_N	DGND – 0.3	DVDD + 0.3	V
Input current to any pin except supply pins	-10	10	mA
Maximum virtual junction temperature, T _J		150	°C
Storage temperature, T _{stg}	-65	150	°C

(1) Stresses beyond those listed under *Absolute Maximum Ratings* may cause permanent damage to the device. These are stress ratings only, and do not imply functional operation of the device at these or any other conditions beyond those indicated. Exposure to absolute-maximum-rated conditions for extended periods may affect device reliability.

7.2 ESD Ratings

		VALUE	UNIT
V _(ESD) Electrostatic discharge	Human body model (HBM), per AEC Q100-002 ⁽¹⁾	±2500	V
	Charged device model (CDM), per AEC Q100-011	±1000	

(1) AEC Q100-002 indicates HBM stressing is done in accordance with the ANSI/ESDA/JEDEC JS-001 specification.

7.3 Recommended Operating Conditions

over operating free-air temperature range (unless otherwise noted)

		MIN	NOM	MAX	UNIT
AVDD	High-side (analog) supply voltage	4.5	5.0	5.5	V
DVDD	Controller-side (digital) supply voltage	3.0	3.3	5.5	V
T _A	Operating ambient temperature range	-40		125	°C

7.4 Thermal Information

THERMAL METRIC ⁽¹⁾		AMC1305x-Q1	UNIT
		DW (SOIC)	
		16 PINS	
R _{θJA}	Junction-to-ambient thermal resistance	80.2	°C/W
R _{θJC(top)}	Junction-to-case (top) thermal resistance	40.5	°C/W
R _{θJB}	Junction-to-board thermal resistance	45.1	°C/W
ψ _{JT}	Junction-to-top characterization parameter	11.9	°C/W
ψ _{JB}	Junction-to-board characterization parameter	44.5	°C/W
R _{θJC(bot)}	Junction-to-case (bottom) thermal resistance	n/a	°C/W

(1) For more information about traditional and new thermal metrics, see the [Semiconductor and IC Package Thermal Metrics](#) application report.

7.5 Power Ratings

PARAMETER	TEST CONDITIONS	VALUE	UNIT
P _D Maximum power dissipation (both sides)	AVDD = 5.5 V, DVDD = 5.5 V, LVDS, R _{LOAD} = 100 Ω	89.1	mW
P _{D1} Maximum power dissipation (high-side supply)	AVDD = 5.5 V	45.1	mW
P _{D2} Maximum power dissipation (low-side supply)	DVDD = 5.5 V, LVDS, R _{LOAD} = 100 Ω	44	mW

7.6 Insulation Specifications

PARAMETER		TEST CONDITIONS	VALUE	UNIT
GENERAL				
CLR	Minimum air gap (clearance) ⁽¹⁾	Shortest pin-to-pin distance through air	≥ 8	mm
CPG	Minimum external tracking (creepage) ⁽¹⁾	Shortest pin-to-pin distance across the package surface	≥ 8	mm
DTI	Distance through insulation	Minimum internal gap (internal clearance) of the double insulation (2 × 0.0135 mm)	0.027	mm
CTI	Comparative tracking index	DIN EN 60112 (VDE 0303-11); IEC 60112	≥ 600	V
	Material group	According to IEC 60664-1	I	
	Overvoltage category per IEC 60664-1	Rated mains voltage ≤ 300 V _{RMS}	I-IV	
		Rated mains voltage ≤ 600 V _{RMS}	I-III	
		Rated mains voltage ≤ 1000 V _{RMS}	I-II	
DIN V VDE V 0884-10 (VDE V 0884-10): 2006-12⁽²⁾				
V _{IORM}	Maximum repetitive peak isolation voltage	At ac voltage (bipolar or unipolar)	1414	V _{PK}
V _{IOWM}	Maximum-rated isolation working voltage	At ac voltage (sine wave)	1000	V _{RMS}
		At dc voltage	1500	V _{DC}
V _{IOTM}	Maximum transient isolation voltage	V _{TEST} = V _{IOTM} , t = 60 s (qualification test)	7000	V _{PK}
		V _{TEST} = 1.2 × V _{IOTM} , t = 1 s (100% production test)	8400	
V _{IOSM}	Maximum surge isolation voltage ⁽³⁾	Test method per IEC 60065, 1.2/50-μs waveform, V _{TEST} = 1.6 × V _{IOSM} = 10000 V _{PK} (qualification)	6250	V _{PK}
q _{pd}	Apparent charge ⁽⁴⁾	Method a, after input/output safety test subgroup 2 / 3, V _{ini} = V _{IOTM} , t _{ini} = 60 s, V _{pd(m)} = 1.2 × V _{IORM} = 1697 V _{PK} , t _m = 10 s	≤ 5	pC
		Method a, after environmental tests subgroup 1, V _{ini} = V _{IOTM} , t _{ini} = 60 s, V _{pd(m)} = 1.6 × V _{IORM} = 2263 V _{PK} , t _m = 10 s	≤ 5	pC
		Method b1, at routine test (100% production) and preconditioning (type test), V _{ini} = V _{IOTM} , t _{ini} = 1 s, V _{pd(m)} = 1.875 × V _{IORM} = 2652 V _{PK} , t _m = 1 s	≤ 5	pC
C _{IO}	Barrier capacitance, input to output ⁽⁵⁾	V _{IO} = 0.5 V _{PP} at 1 MHz	1.2	pF
R _{IO}	Insulation resistance, input to output ⁽⁵⁾	V _{IO} = 500 V at T _S = 150°C	> 10 ⁹	Ω
	Pollution degree		2	
	Climatic category		40/125/21	
UL1577				
V _{ISO}	Withstand isolation voltage	V _{TEST} = V _{ISO} = 5000 V _{RMS} or 7000 V _{DC} , t = 60 s (qualification test), V _{TEST} = 1.2 × V _{ISO} = 6000 V _{RMS} , t = 1 s (100% production test)	5000	V _{RMS}

- (1) Apply creepage and clearance requirements according to the specific equipment isolation standards of an application. Care must be taken to maintain the creepage and clearance distance of a board design to ensure that the mounting pads of the isolator on the printed circuit board (PCB) do not reduce this distance. Creepage and clearance on a PCB become equal in certain cases. Techniques such as inserting grooves or ribs on the PCB are used to help increase these specifications.
- (2) This coupler is suitable for *safe electrical insulation* only within the safety ratings. Compliance with the safety ratings shall be ensured by means of suitable protective circuits.
- (3) Testing is carried out in air or oil to determine the intrinsic surge immunity of the isolation barrier.
- (4) Apparent charge is electrical discharge caused by a partial discharge (pd).
- (5) All pins on each side of the barrier are tied together, creating a two-pin device.

7.7 Safety-Related Certifications

VDE	UL
Certified according to DIN V VDE V 0884-10 (VDE V 0884-10): 2006-12, DIN EN 60950-1 (VDE 0805 Teil 1): 2014-08, and DIN EN 60095 (VDE 0860): 2005-11	Recognized under UL1577 component recognition and CSA component acceptance NO 5 programs
Reinforced insulation	Single protection
File number: 40040142	File number: E181974

7.8 Safety Limiting Values

Safety limiting intends to prevent potential damage to the isolation barrier upon failure of input or output (I/O) circuitry. A failure of the I/O circuitry may allow low resistance to ground or the supply and, without current limiting, dissipate sufficient power to overheat the die and damage the isolation barrier, potentially leading to secondary system failures.

PARAMETER	TEST CONDITIONS	MIN	TYP	MAX	UNIT
I _S Safety input, output, or supply current	$\theta_{JA} = 80.2^{\circ}\text{C/W}$, AVDD = DVDD = 5.5 V, T _J = 150°C, T _A = 25°C, see Figure 3			283	mA
	$\theta_{JA} = 80.2^{\circ}\text{C/W}$, AVDD = DVDD = 3.6 V, T _J = 150°C, T _A = 25°C, see Figure 3			432	mA
P _S Safety input, output, or total power	$\theta_{JA} = 80.2^{\circ}\text{C/W}$, T _J = 150°C, T _A = 25°C, see Figure 4			1558 ⁽¹⁾	mW
T _S Maximum safety temperature				150	°C

(1) Input, output, or the sum of input and output power must not exceed this value.

The maximum safety temperature is the maximum junction temperature specified for the device. The power dissipation and junction-to-air thermal impedance of the device installed in the application hardware determines the junction temperature. The assumed junction-to-air thermal resistance in the [Thermal Information](#) table is that of a device installed on a high-K test board for leaded surface-mount packages. The power is the recommended maximum input voltage times the current. The junction temperature is then the ambient temperature plus the power times the junction-to-air thermal resistance.

7.9 Electrical Characteristics: AMC1305M05-Q1

All minimum and maximum specifications at $T_A = -40^\circ\text{C}$ to $+125^\circ\text{C}$, $AVDD = 4.5\text{ V}$ to 5.5 V , $DVDD = 3.0\text{ V}$ to 5.5 V , $AINP = -50\text{ mV}$ to 50 mV , $AINN = 0\text{ V}$, and sinc³ filter with OSR = 256, unless otherwise noted. Typical values are at $T_A = 25^\circ\text{C}$, $CLKIN = 20\text{ MHz}$, $AVDD = 5.0\text{ V}$, and $DVDD = 3.3\text{ V}$.

PARAMETER		TEST CONDITIONS	MIN	TYP	MAX	UNIT
ANALOG INPUTS						
V_{Clipping}	Maximum differential voltage input range (AINP-AINN)			±62.5		mV
FSR	Specified linear full-scale range (AINP-AINN)		-50		50	mV
V_{CM}	Operating common-mode input range		-0.032		$AVDD - 2$	V
C_{ID}	Differential input capacitance			2		pF
I_{IB}	Input current	Inputs shorted to AGND	-97	-72	-57	µA
R_{ID}	Differential input resistance			5		kΩ
I_{OS}	Input offset current			±5		nA
CMTI	Common-mode transient immunity		15			kV/µs
CMRR	Common-mode rejection ratio	$f_{\text{IN}} = 0\text{ Hz}$, $V_{\text{CM min}} \leq V_{\text{IN}} \leq V_{\text{CM max}}$		-104		dB
		f_{IN} from 0.1 Hz to 50 kHz, $V_{\text{CM min}} \leq V_{\text{IN}} \leq V_{\text{CM max}}$		-75		
BW	Input bandwidth			800		kHz
DC ACCURACY						
DNL	Differential nonlinearity	Resolution: 16 bits	-0.99		0.99	LSB
INL	Integral nonlinearity ⁽¹⁾	Resolution: 16 bits	-5	±1.5	5	LSB
E_{O}	Offset error	Initial, at 25°C	-50	±2.5	50	µV
TCE_{O}	Offset error thermal drift ⁽²⁾		-1.3		1.3	µV/°C
E_{G}	Gain error	Initial, at 25°C	-0.3%	-0.02%	0.3%	
TCE_{G}	Gain error thermal drift ⁽³⁾		-40	±20	40	ppm/°C
PSRR	Power-supply rejection ratio	V_{AVDD} from 4.5 to 5.5V, at dc		105		dB
AC ACCURACY						
SNR	Signal-to-noise ratio	$f_{\text{IN}} = 1\text{ kHz}$	76	81		dB
SINAD	Signal-to-noise + distortion	$f_{\text{IN}} = 1\text{ kHz}$	76	81		dB
THD	Total harmonic distortion	$f_{\text{IN}} = 1\text{ kHz}$		-90	-83	dB
SFDR	Spurious-free dynamic range	$f_{\text{IN}} = 1\text{ kHz}$	83	92		dB
DIGITAL INPUTS/OUTPUTS						
External Clock						
f_{CLKIN}	Input clock frequency		5	20	20.1	MHz
Duty _{CLKIN}	Duty cycle	$5\text{ MHz} \leq f_{\text{CLKIN}} \leq 20.1\text{ MHz}$	40%	50%	60%	
CMOS Logic Family, CMOS with Schmitt-Trigger						
I_{IN}	Input current	$DGND \leq V_{\text{IN}} \leq DVDD$	-1		1	µA
C_{IN}	Input capacitance			5		pF
V_{IH}	High-level input voltage		$0.7 \times DVDD$		$DVDD + 0.3$	V
V_{IL}	Low-level input voltage		-0.3		$0.3 \times DVDD$	V
C_{LOAD}	Output load capacitance	$f_{\text{CLKIN}} = 20\text{ MHz}$		30		pF
V_{OH}	High-level output voltage	$I_{\text{OH}} = -20\text{ µA}$	$DVDD - 0.1$			V
		$I_{\text{OH}} = -4\text{ mA}$	$DVDD - 0.4$			
V_{OL}	Low-level output voltage	$I_{\text{OL}} = 20\text{ µA}$			0.1	V
		$I_{\text{OL}} = 4\text{ mA}$			0.4	

(1) Integral nonlinearity is defined as the maximum deviation from a straight line passing through the end-points of the ideal ADC transfer function expressed as number of LSBs or as a percent of the specified linear full-scale range FSR.

(2) Offset error drift is calculated using the box method as described by the following equation:

$$TCE_{\text{O}} = \frac{\text{value}_{\text{MAX}} - \text{value}_{\text{MIN}}}{\text{TempRange}}$$

(3) Gain error drift is calculated using the box method as described by the following equation:

$$TCE_{\text{G}} (\text{ppm}) = \left(\frac{\text{value}_{\text{MAX}} - \text{value}_{\text{MIN}}}{\text{value} \times \text{TempRange}} \right) \times 10^6$$

Electrical Characteristics: AMC1305M05-Q1 (continued)

All minimum and maximum specifications at $T_A = -40^\circ\text{C}$ to $+125^\circ\text{C}$, $AVDD = 4.5\text{ V}$ to 5.5 V , $DVDD = 3.0\text{ V}$ to 5.5 V , $A\text{INP} = -50\text{ mV}$ to 50 mV , $A\text{INN} = 0\text{ V}$, and sinc³ filter with $\text{OSR} = 256$, unless otherwise noted. Typical values are at $T_A = 25^\circ\text{C}$, $\text{CLKIN} = 20\text{ MHz}$, $AVDD = 5.0\text{ V}$, and $DVDD = 3.3\text{ V}$.

PARAMETER		TEST CONDITIONS	MIN	TYP	MAX	UNIT
POWER SUPPLY						
AVDD	High-side supply voltage		4.5	5.0	5.5	V
I _{AVDD}	High-side supply current			6.5	8.2	mA
P _{AVDD}	High-side power dissipation			32.5	45.1	mW
DVDD	Controller-side supply voltage		3.0	3.3	5.5	V
I _{DVDD}	Controller-side supply current	3.0 V ≤ DVDD ≤ 3.6 V		2.7	4.0	mA
		4.5 V ≤ DVDD ≤ 5.5 V		3.2	5.5	
P _{DVDD}	Controller-side power dissipation	3.0 V ≤ DVDD ≤ 3.6 V		8.9	14.4	mW
		4.5 V ≤ DVDD ≤ 5.5 V		16.0	30.3	

7.10 Electrical Characteristics: AMC1305x25-Q1

All minimum and maximum specifications at $T_A = -40^\circ\text{C}$ to 125°C , $AVDD = 4.5\text{ V}$ to 5.5 V , $DVDD = 3.0\text{ V}$ to 5.5 V , $AINP = -250\text{ mV}$ to 250 mV , $AINN = 0\text{ V}$, and sinc³ filter with $OSR = 256$, unless otherwise noted. Typical values are at $T_A = 25^\circ\text{C}$, $CLKIN = 20\text{ MHz}$, $AVDD = 5.0\text{ V}$, and $DVDD = 3.3\text{ V}$.

PARAMETER		TEST CONDITIONS	MIN	TYP	MAX	UNIT
ANALOG INPUTS						
$V_{Clipping}$	Maximum differential voltage input range (AINP-AINN)			± 312.5		mV
FSR	Specified linear full-scale range (AINP-AINN)		-250		250	mV
V_{CM}	Operating common-mode input range		-0.16		$AVDD - 2$	V
C_{ID}	Differential input capacitance			1		pF
I_{IB}	Input current	Inputs shorted to AGND	-82	-60	-48	μA
R_{ID}	Differential input resistance			25		k Ω
I_{OS}	Input offset current			± 5		nA
CMTI	Common-mode transient immunity		15			kV/ μs
CMRR	Common-mode rejection ratio	$f_{IN} = 0\text{ Hz}$, $V_{CM\ min} \leq V_{IN} \leq V_{CM\ max}$		-95		dB
		f_{IN} from 0.1 Hz to 50 kHz, $V_{CM\ min} \leq V_{IN} \leq V_{CM\ max}$		-76		
BW	Input bandwidth			1000		kHz
DC ACCURACY						
DNL	Differential nonlinearity	Resolution: 16 bits	-0.99		0.99	LSB
INL	Integral nonlinearity ⁽¹⁾	Resolution: 16 bits	-4	± 1.5	4	LSB
E_O	Offset error	Initial, at 25°C	-150	± 40	150	μV
TCE_O	Offset error thermal drift ⁽²⁾		-1.3		1.3	$\mu\text{V}/^\circ\text{C}$
E_G	Gain error	Initial, at 25°C	-0.3	-0.02	0.3	%FS
TCE_G	Gain error thermal drift ⁽³⁾		-40	± 20	40	ppm/ $^\circ\text{C}$
PSRR	Power-supply rejection ratio	V_{AVDD} from 4.5 V to 5.5 V, at dc		90		dB
AC ACCURACY						
SNR	Signal-to-noise ratio	$f_{IN} = 1\text{ kHz}$	82	85		dB
SINAD	Signal-to-noise + distortion	$f_{IN} = 1\text{ kHz}$	80	84		dB
THD	Total harmonic distortion	$f_{IN} = 1\text{ kHz}$		-90	-83	dB
SFDR	Spurious-free dynamic range	$f_{IN} = 1\text{ kHz}$	83	92		dB
DIGITAL INPUTS/OUTPUTS						
External Clock						
f_{CLKIN}	Input clock frequency		5	20	20.1	MHz
Duty _{CLKIN}	Duty cycle	$5\text{ MHz} \leq f_{CLKIN} \leq 20.1\text{ MHz}$	40%	50%	60%	
CMOS Logic Family (AMC1305M25-Q1), CMOS with Schmitt-Trigger						
I_{IN}	Input current	$DGND \leq V_{IN} \leq DVDD$	-1		1	μA
C_{IN}	Input capacitance			5		pF
V_{IH}	High-level input voltage		$0.7 \times DVDD$		$DVDD + 0.3$	V
V_{IL}	Low-level input voltage		-0.3		$0.3 \times DVDD$	V
C_{LOAD}	Output load capacitance	$f_{CLKIN} = 20\text{ MHz}$		30		pF
V_{OH}	High-level output voltage	$I_{OH} = -20\ \mu\text{A}$	$DVDD - 0.1$			V
		$I_{OH} = -4\ \text{mA}$	$DVDD - 0.4$			
V_{OL}	Low-level output voltage	$I_{OL} = 20\ \mu\text{A}$			0.1	V
		$I_{OL} = 4\ \text{mA}$			0.4	

(1) Integral nonlinearity is defined as the maximum deviation from a straight line passing through the end-points of the ideal ADC transfer function expressed as the number of LSBs or as a percent of the specified linear full-scale range FSR.

(2) Offset error drift is calculated using the box method as described by the following equation:

$$TCE_O = \frac{value_{MAX} - value_{MIN}}{TempRange}$$

(3) Gain error drift is calculated using the box method as described by the following equation:

$$TCE_G (ppm) = \left(\frac{value_{MAX} - value_{MIN}}{value \times TempRange} \right) \times 10^6$$

Electrical Characteristics: AMC1305x25-Q1 (continued)

All minimum and maximum specifications at $T_A = -40^\circ\text{C}$ to 125°C , $AVDD = 4.5\text{ V}$ to 5.5 V , $DVDD = 3.0\text{ V}$ to 5.5 V , $A_{INP} = -250\text{ mV}$ to 250 mV , $A_{INN} = 0\text{ V}$, and sinc³ filter with $OSR = 256$, unless otherwise noted. Typical values are at $T_A = 25^\circ\text{C}$, $CLKIN = 20\text{ MHz}$, $AVDD = 5.0\text{ V}$, and $DVDD = 3.3\text{ V}$.

PARAMETER		TEST CONDITIONS	MIN	TYP	MAX	UNIT
LVDS Logic Family (AMC1305L25-Q1)						
V_{OD}	Differential output voltage	$R_{LOAD} = 100\ \Omega$	250	350	450	mV
V_{OCM}	Output common-mode voltage		1.125	1.23	1.375	V
I_S	Output short-circuit current				24	mA
V_{ICM}	Input common-mode voltage	$V_{ID} = 100\text{ mV}$	0.05	1.25	3.25	V
V_{ID}	Differential input voltage		100	350	600	mV
I_{IN}	Input current	$DGND \leq V_{IN} \leq 3.3\text{ V}$	-24	0	20	μA
POWER SUPPLY						
$AVDD$	High-side supply voltage		4.5	5.0	5.5	V
I_{AVDD}	High-side supply current			6.5	8.2	mA
P_{AVDD}	High-side power dissipation			32.5	45.1	mW
$DVDD$	Controller-side supply voltage		3.0	3.3	5.5	V
I_{DVDD}	Controller-side supply current	AMC1305L25-Q1, $R_{LOAD} = 100\ \Omega$		6.1	8.0	mA
		AMC1305M25-Q1, $3.0 \leq DVDD \leq 3.6\text{ V}$, $C_{LOAD} = 5\text{ pF}$		2.7	4.0	
		AMC1305M25-Q1, $4.5 \leq DVDD \leq 5.5\text{ V}$, $C_{LOAD} = 5\text{ pF}$		3.2	5.5	
P_{DVDD}	Controller-side power dissipation	AMC1305L25-Q1, $R_{LOAD} = 100\ \Omega$		20.1	44.0	mW
		AMC1305M25-Q1, $3.0 \leq DVDD \leq 3.6\text{ V}$, $C_{LOAD} = 5\text{ pF}$		8.9	14.4	
		AMC1305M25-Q1, $4.5 \leq DVDD \leq 5.5\text{ V}$, $C_{LOAD} = 5\text{ pF}$		16.0	30.3	

7.11 Switching Characteristics

over operating free-air temperature range (unless otherwise noted)

PARAMETER		MIN	TYP	MAX	UNIT
t_{CLK}	CLKIN, CLKIN_N clock period	49.75	50	200	ns
t_{HIGH}	CLKIN, CLKIN_N clock high time	19.9	25	120	ns
t_{LOW}	CLKIN, CLKIN_N clock low time	19.9	25	120	ns
t_D	Falling edge of CLKIN, CLKIN_N to DOUT, DOUT_N valid delay, $C_{LOAD} = 5\text{ pF}$	0		15	ns
t_{iSTART}	Interface startup time (DVDD at 3.0 V min to DOUT, DOUT_N valid with $AVDD \geq 4.5\text{ V}$)	32		32	CLKIN cycles
t_{ASTART}	Analog startup time (AVDD step up to 4.5 V with $DVDD \geq 3.0\text{ V}$)		1		ms

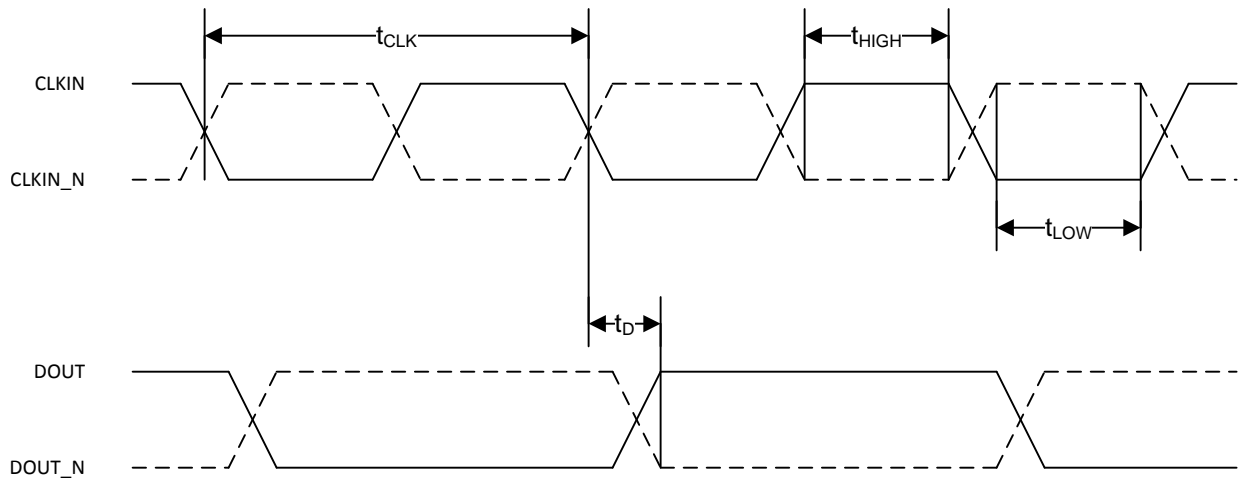

Figure 1. Digital Interface Timing

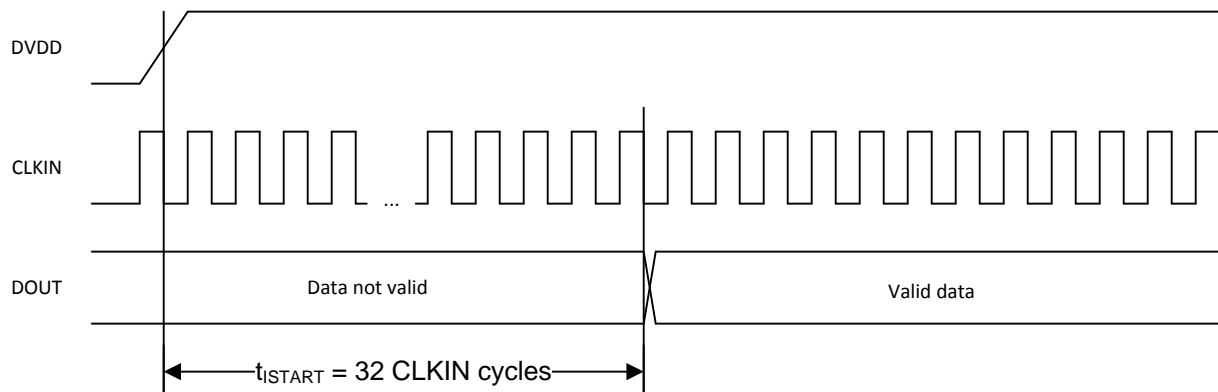
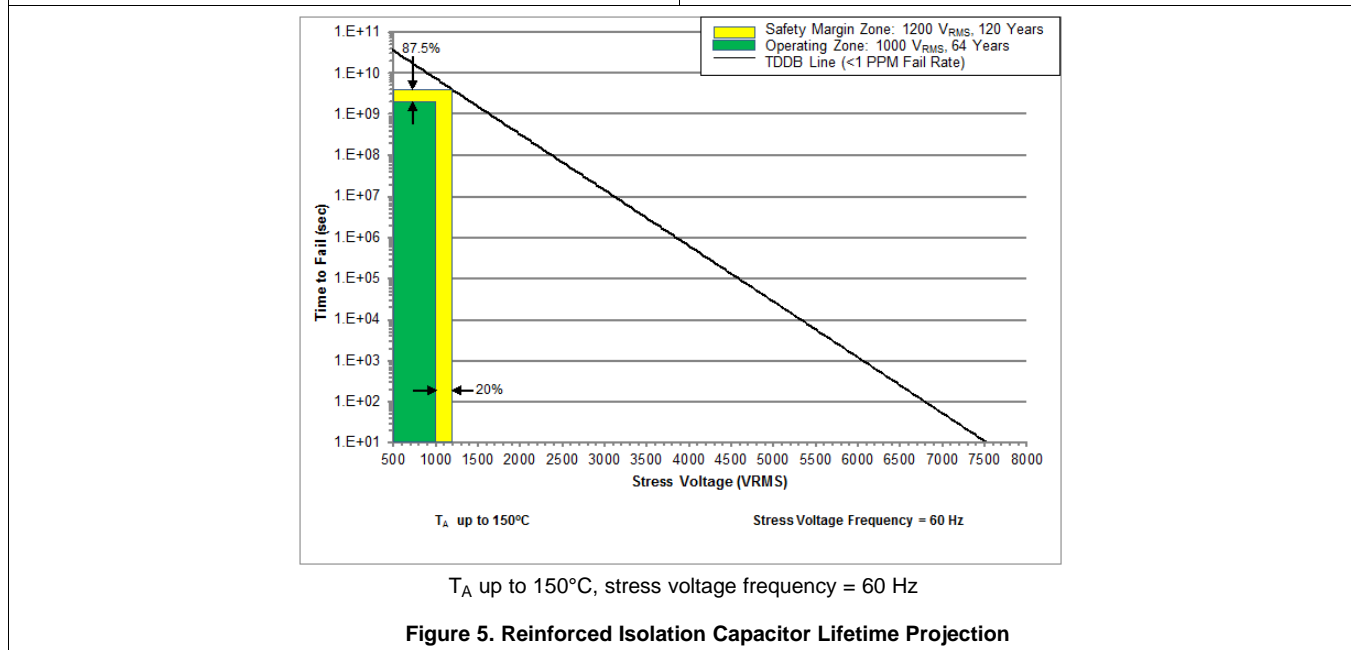
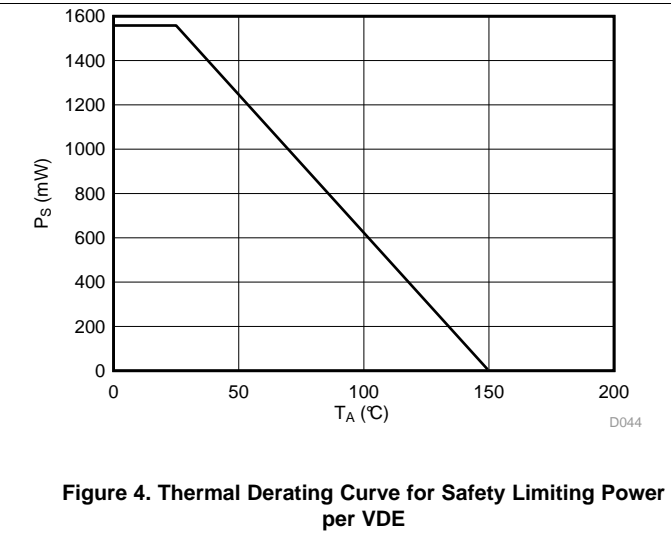
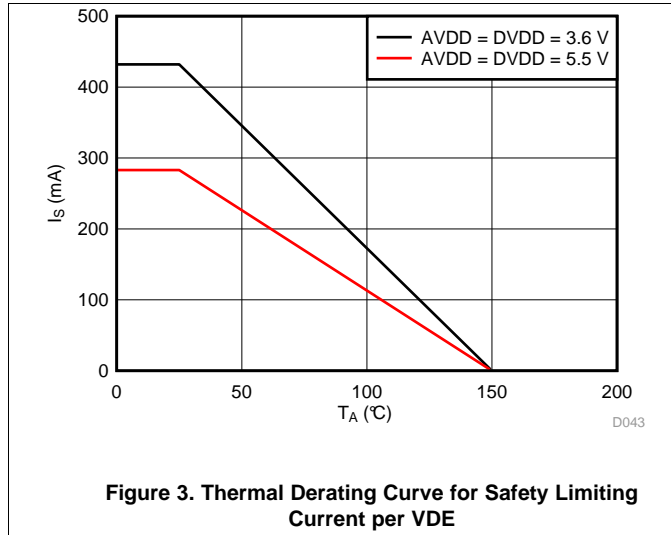

Figure 2. Digital Interface Startup Timing

7.12 Insulation Characteristics Curves



7.13 Typical Characteristics

At $T_A = 25^\circ\text{C}$, $AVDD = 5.0\text{ V}$, $DVDD = 3.3\text{ V}$, $AINP = -250\text{ mV}$ to 250 mV , $AINN = 0\text{ V}$, $f_{CLKIN} = 20\text{ MHz}$, and sinc³ filter with OSR = 256, unless otherwise noted.

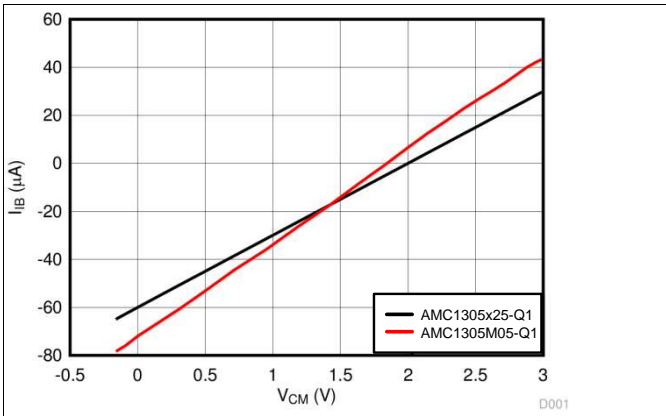

Figure 6. Input Current vs Input Common-Mode Voltage

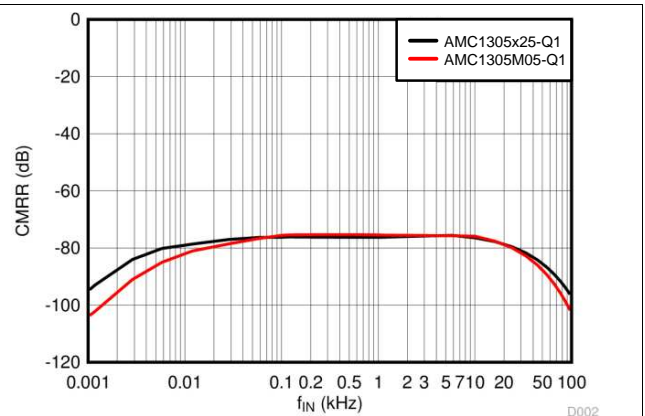

Figure 7. Common-Mode Rejection Ratio vs Input Signal Frequency

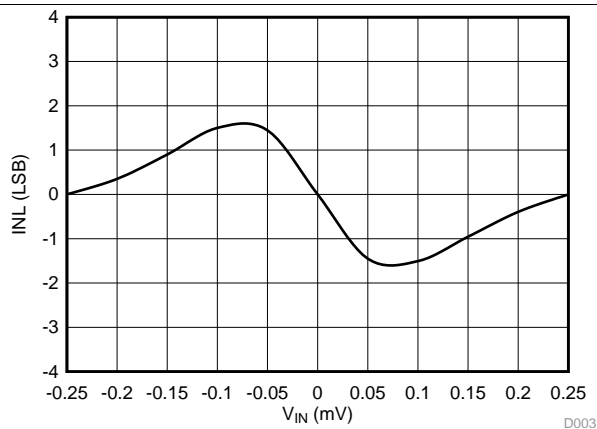

Figure 8. Integral Nonlinearity vs Input Signal Amplitude

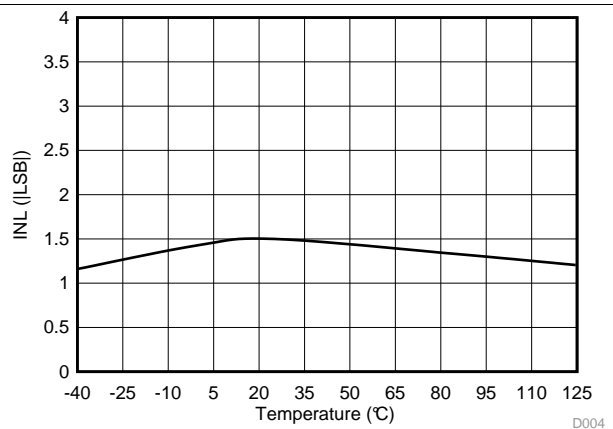

Figure 9. Integral Nonlinearity vs Temperature

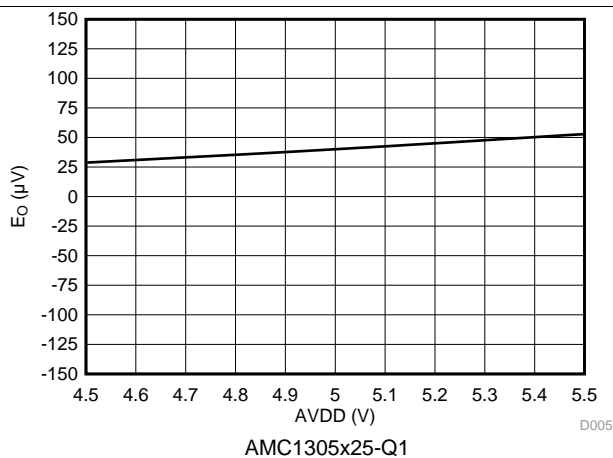

Figure 10. Offset Error vs High-Side Supply Voltage

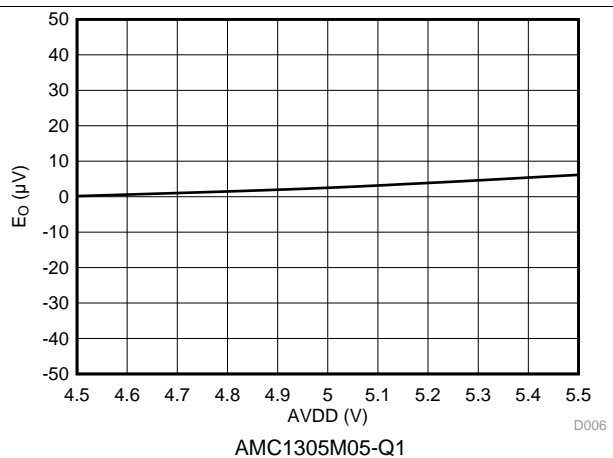

Figure 11. Offset Error vs High-Side Supply Voltage

Typical Characteristics (continued)

At $T_A = 25^\circ\text{C}$, $AVDD = 5.0\text{ V}$, $DVDD = 3.3\text{ V}$, $AINP = -250\text{ mV to }250\text{ mV}$, $AINN = 0\text{ V}$, $f_{CLKIN} = 20\text{ MHz}$, and sinc³ filter with OSR = 256, unless otherwise noted.

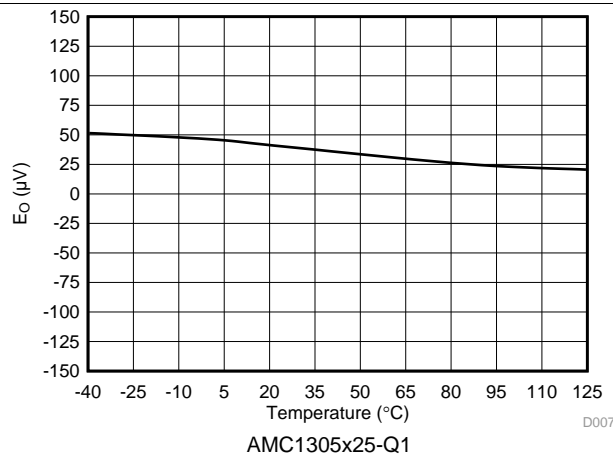

Figure 12. Offset Error vs Temperature

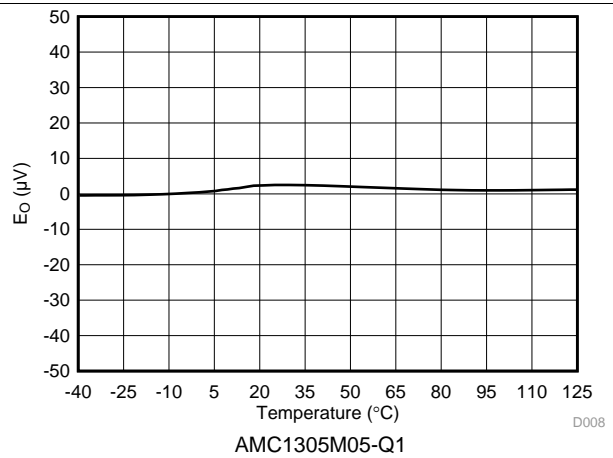

Figure 13. Offset Error vs Temperature

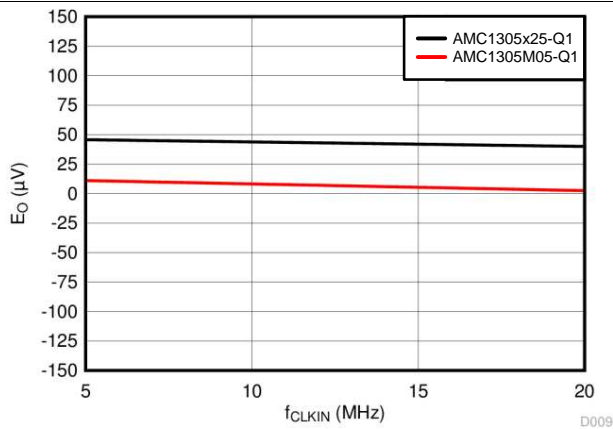

Figure 14. Offset Error vs Clock Frequency

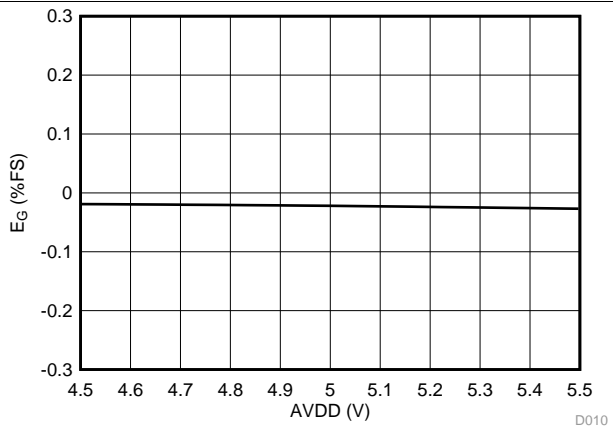

Figure 15. Gain Error vs High-Side Supply Voltage

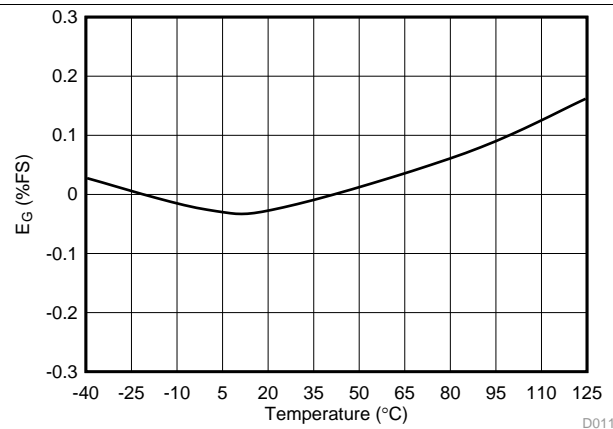

Figure 16. Gain Error vs Temperature

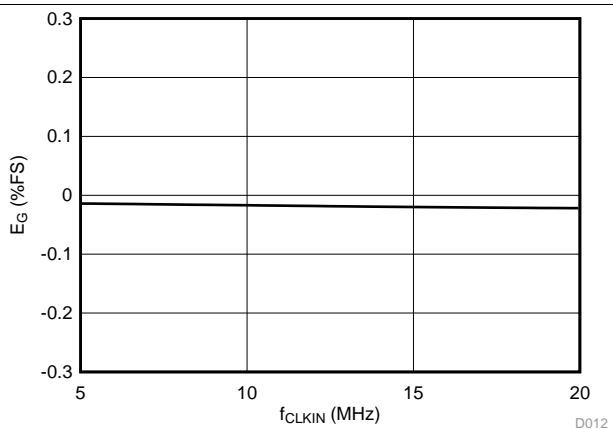

Figure 17. Gain Error vs Clock Frequency

Typical Characteristics (continued)

At $T_A = 25^\circ\text{C}$, $AVDD = 5.0\text{ V}$, $DVDD = 3.3\text{ V}$, $A\text{INP} = -250\text{ mV to }250\text{ mV}$, $A\text{INN} = 0\text{ V}$, $f_{\text{CLKIN}} = 20\text{ MHz}$, and sinc³ filter with OSR = 256, unless otherwise noted.

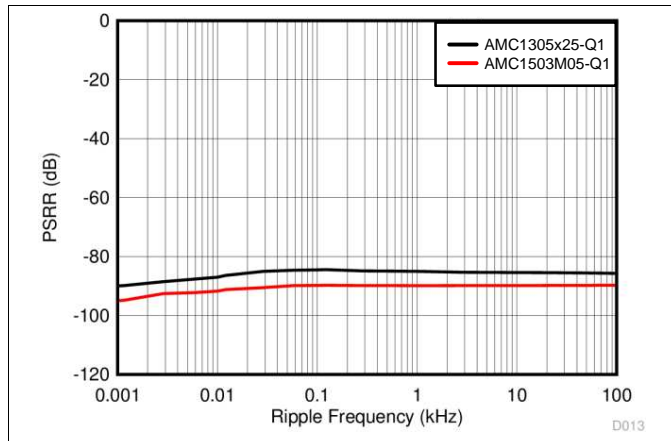

Figure 18. Power-Supply Rejection Ratio vs Ripple Frequency

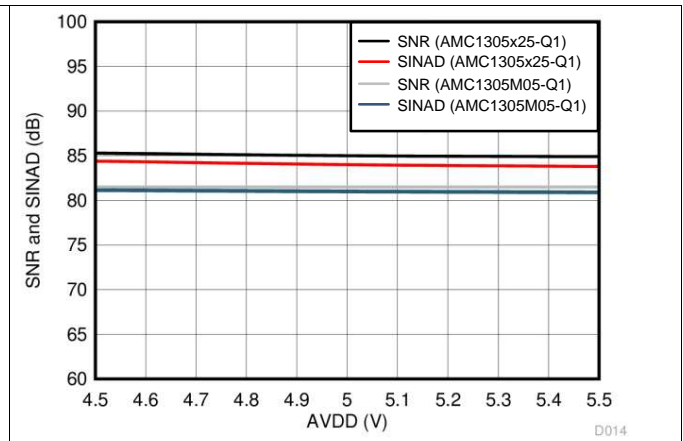

Figure 19. SNR and SINAD vs High-Side Supply Voltage

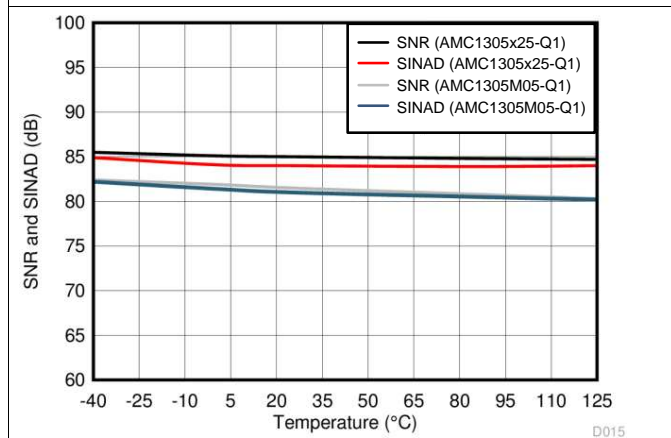

Figure 20. SNR and SINAD vs Temperature

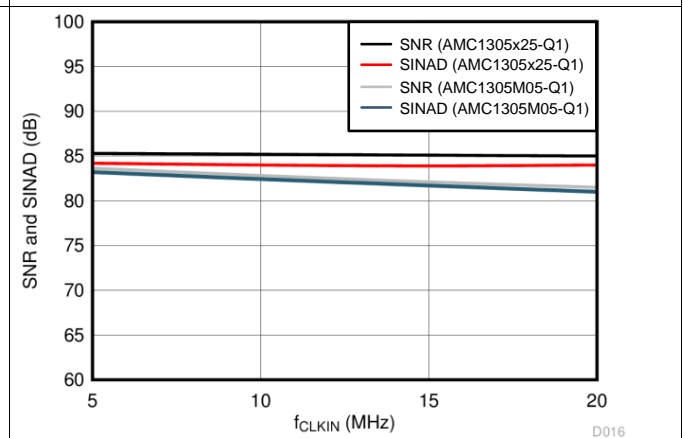

Figure 21. SNR and SINAD vs Clock Frequency

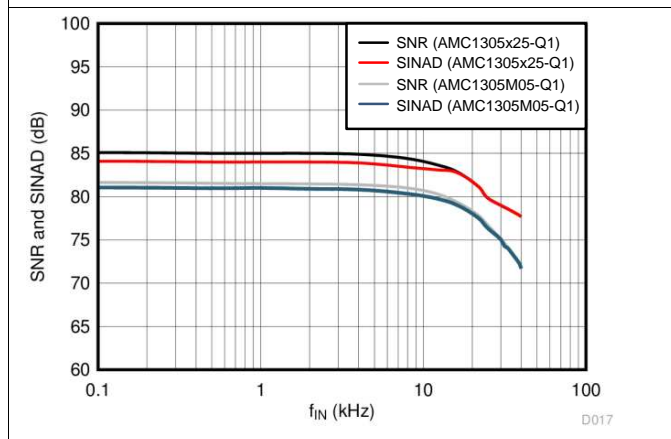

Figure 22. SNR and SINAD vs Input Signal Frequency

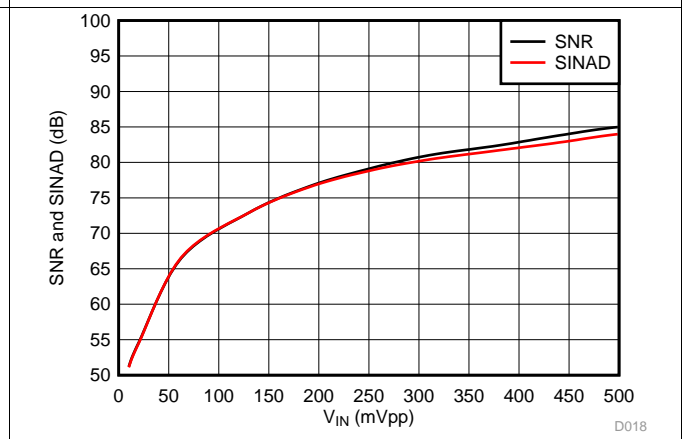
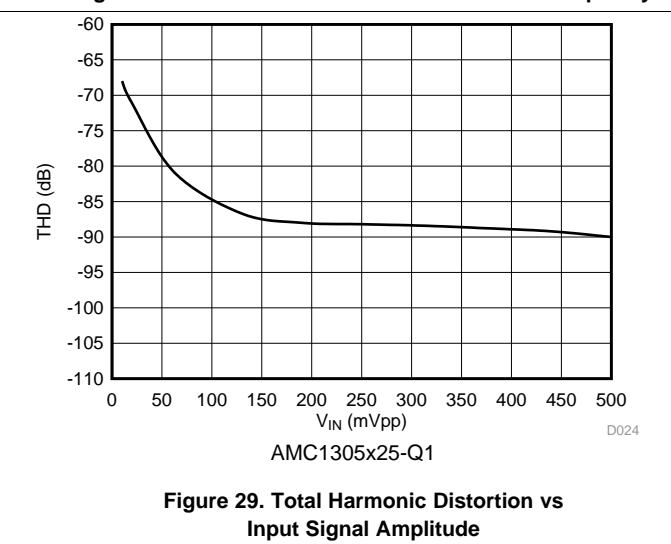
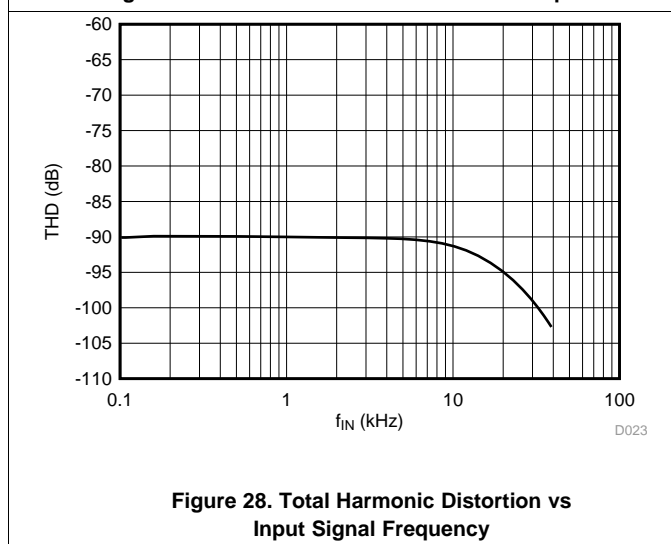
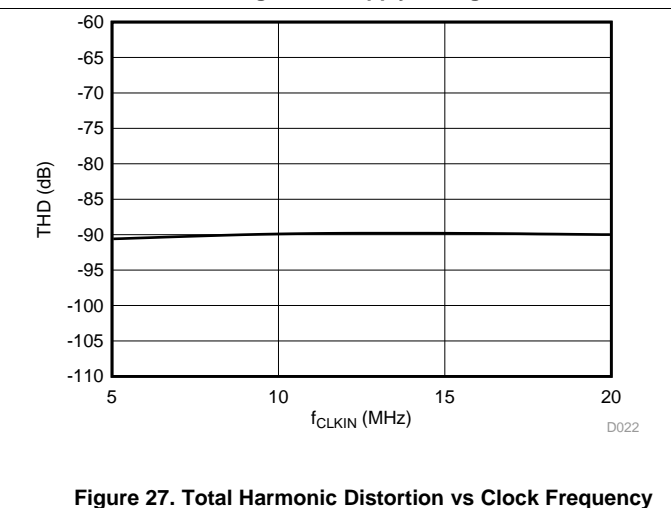
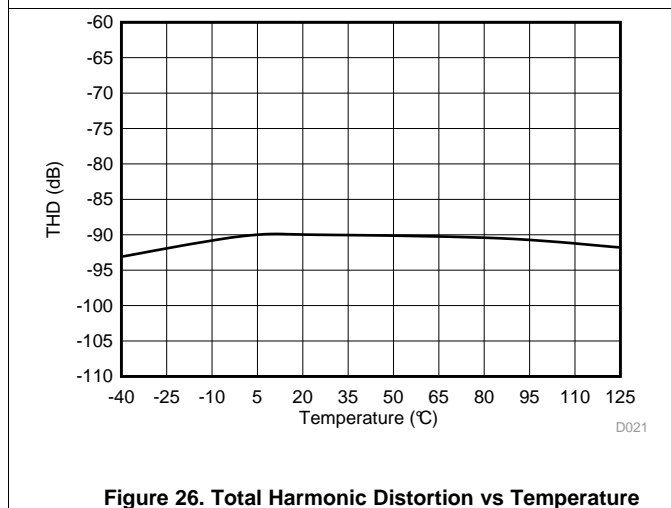
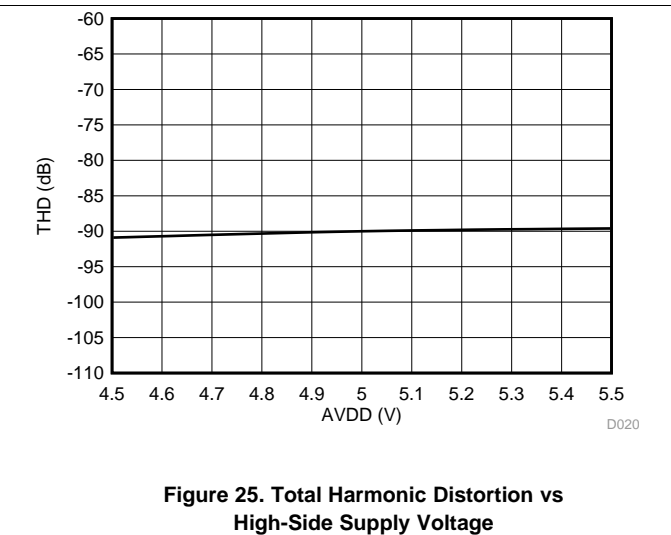
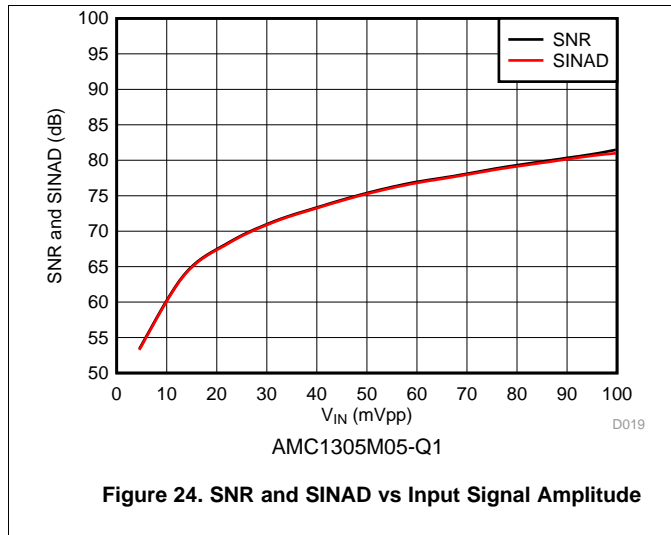

Figure 23. SNR and SINAD vs Input Signal Amplitude

Typical Characteristics (continued)

At $T_A = 25^\circ\text{C}$, $AV_{DD} = 5.0\text{ V}$, $DV_{DD} = 3.3\text{ V}$, $A_{INP} = -250\text{ mV to } 250\text{ mV}$, $A_{INN} = 0\text{ V}$, $f_{CLKIN} = 20\text{ MHz}$, and sinc³ filter with OSR = 256, unless otherwise noted.



Typical Characteristics (continued)

At $T_A = 25^\circ\text{C}$, $AV_{DD} = 5.0\text{ V}$, $DV_{DD} = 3.3\text{ V}$, $A_{INP} = -250\text{ mV to }250\text{ mV}$, $A_{INN} = 0\text{ V}$, $f_{CLKIN} = 20\text{ MHz}$, and sinc³ filter with OSR = 256, unless otherwise noted.

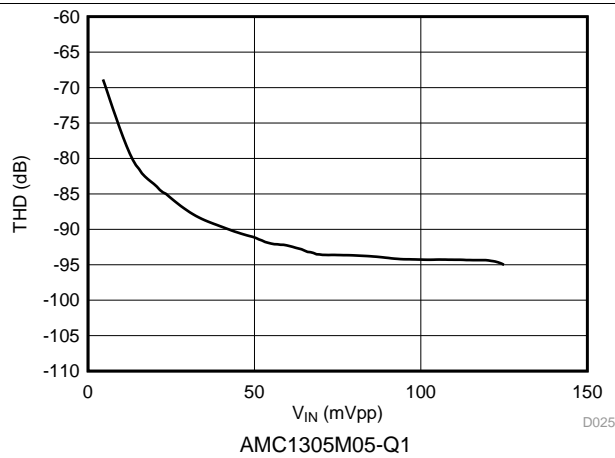

Figure 30. Total Harmonic Distortion vs Input Signal Amplitude

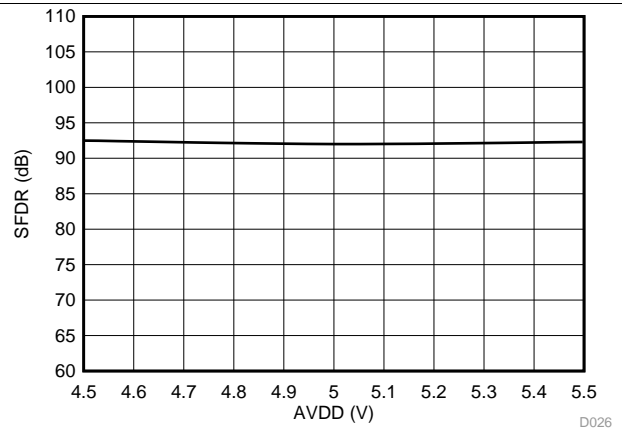

Figure 31. Spurious-Free Dynamic Range vs High-Side Supply Voltage

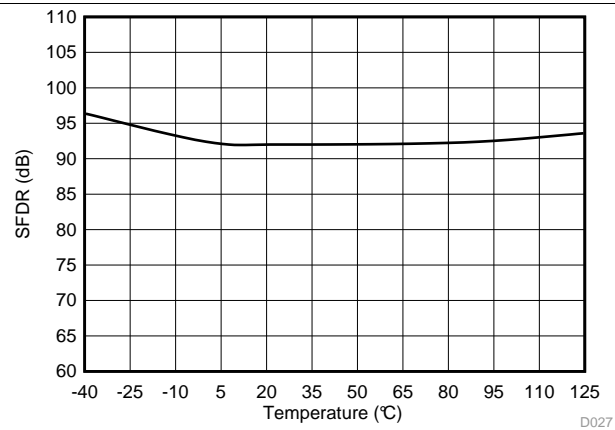

Figure 32. Spurious-Free Dynamic Range vs Temperature

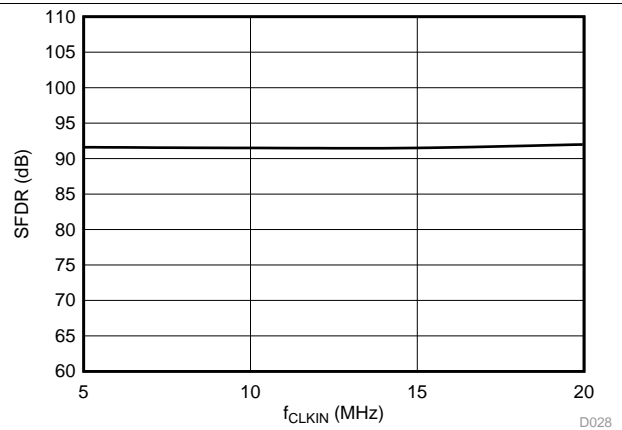

Figure 33. Spurious-Free Dynamic Range vs Clock Frequency

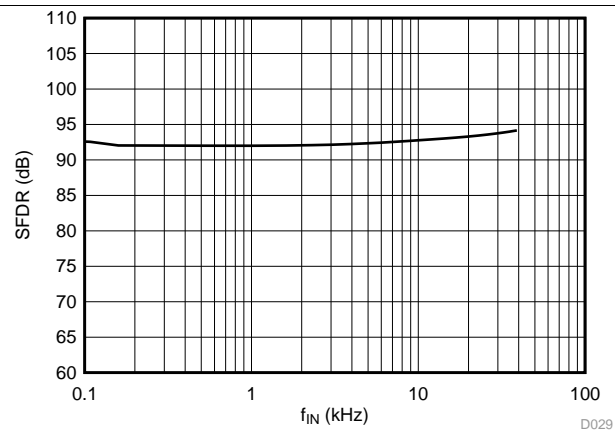

Figure 34. Spurious-Free Dynamic Range vs Input Signal Frequency

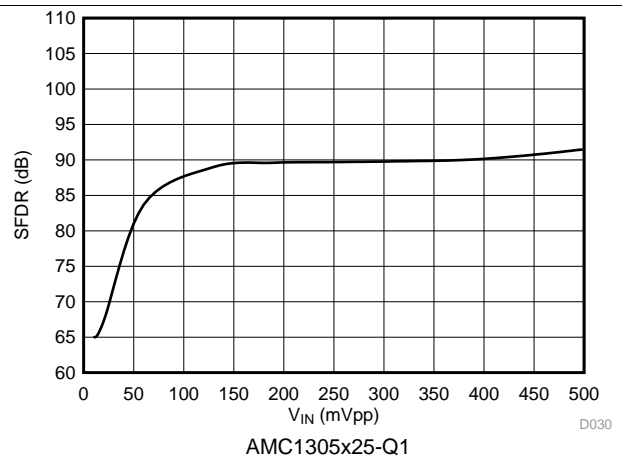
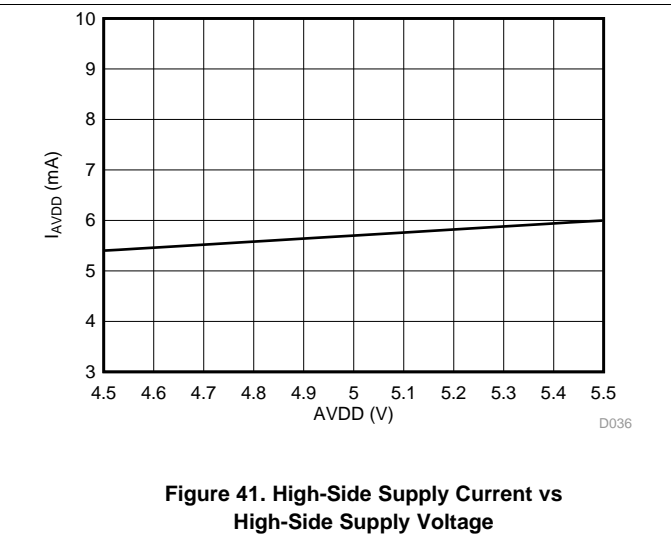
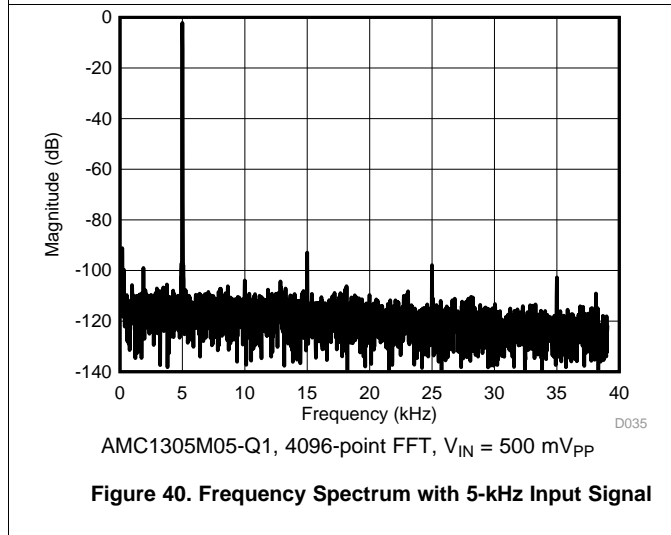
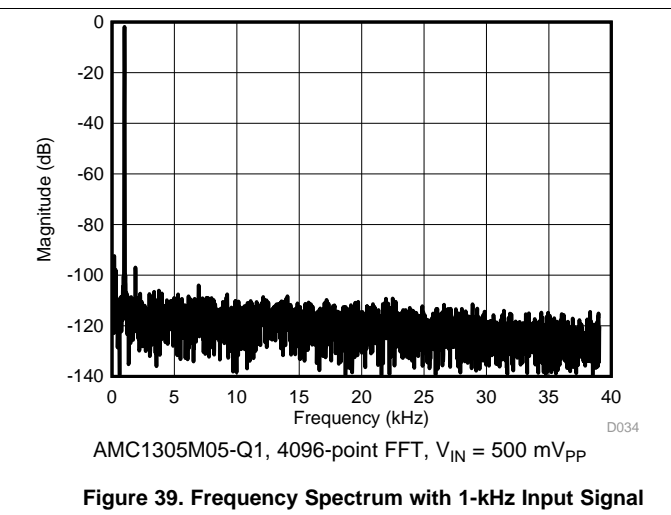
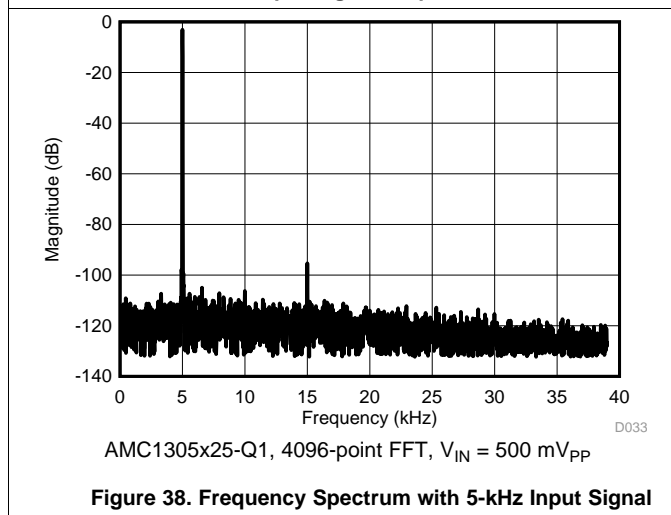
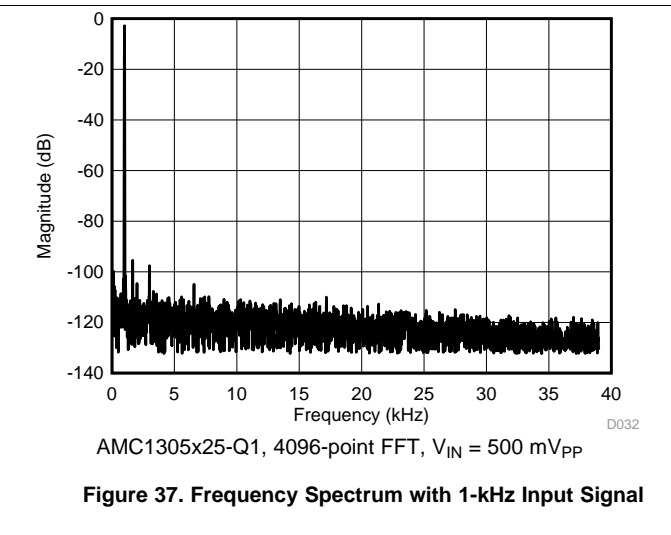
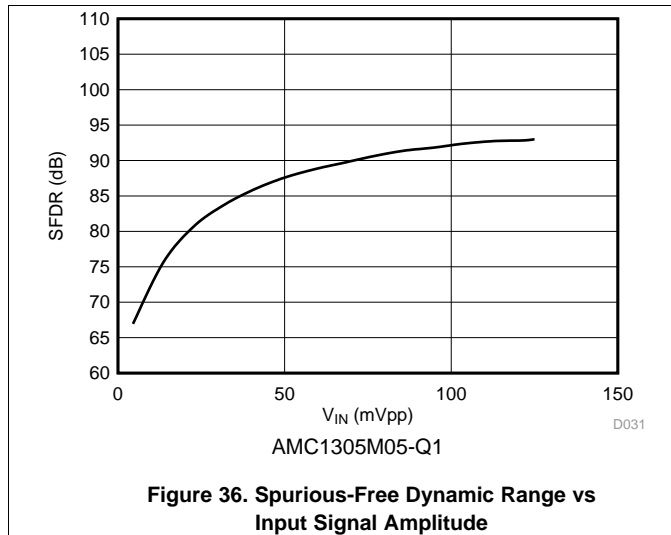

Figure 35. Spurious-Free Dynamic Range vs Input Signal Amplitude

Typical Characteristics (continued)

At $T_A = 25^\circ\text{C}$, $AV_{DD} = 5.0\text{ V}$, $DV_{DD} = 3.3\text{ V}$, $A_{INP} = -250\text{ mV to } 250\text{ mV}$, $A_{INN} = 0\text{ V}$, $f_{CLKIN} = 20\text{ MHz}$, and sinc³ filter with OSR = 256, unless otherwise noted.



Typical Characteristics (continued)

At $T_A = 25^\circ\text{C}$, $AVDD = 5.0\text{ V}$, $DVDD = 3.3\text{ V}$, $A\text{INP} = -250\text{ mV to }250\text{ mV}$, $A\text{INN} = 0\text{ V}$, $f_{\text{CLKIN}} = 20\text{ MHz}$, and sinc³ filter with OSR = 256, unless otherwise noted.

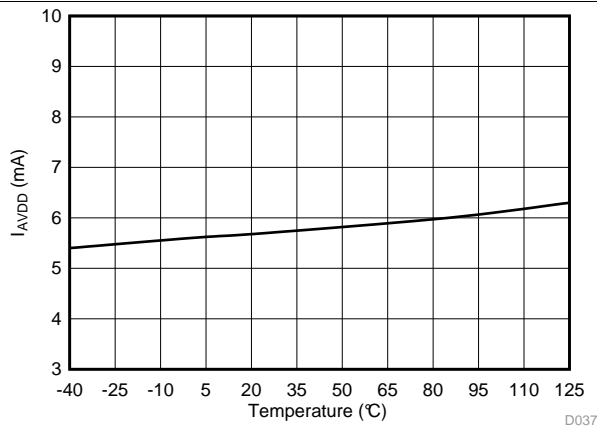

Figure 42. High-Side Supply Current vs Temperature

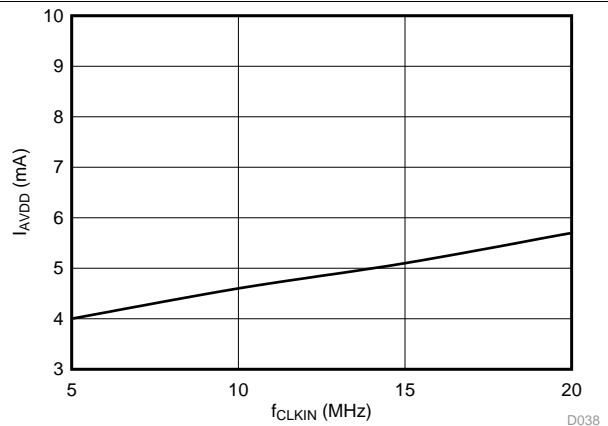

Figure 43. High-Side Supply Current vs Clock Frequency

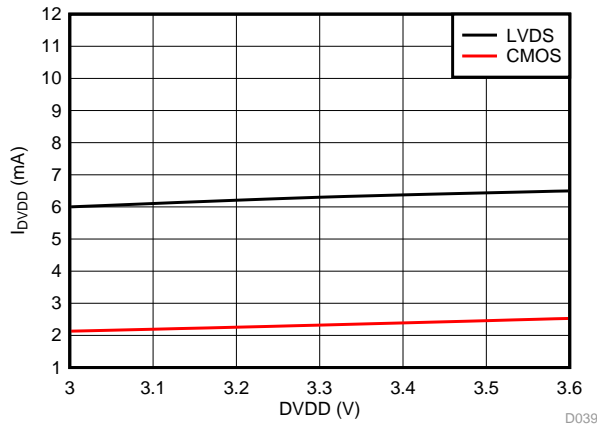

Figure 44. Controller-Side Supply Current vs Controller-Side Supply Voltage (3.3 V, nom)

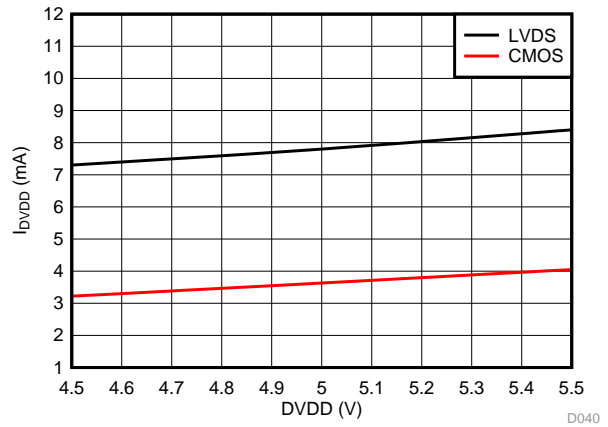

Figure 45. Controller-Side Supply Current vs Controller-Side Supply Voltage (5 V, nom)

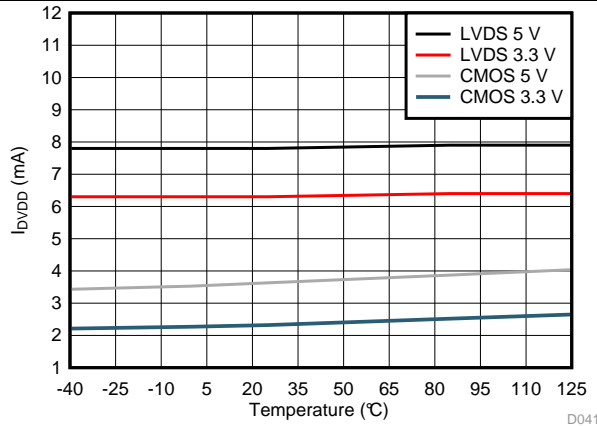

Figure 46. Controller-Side Supply Current vs Temperature

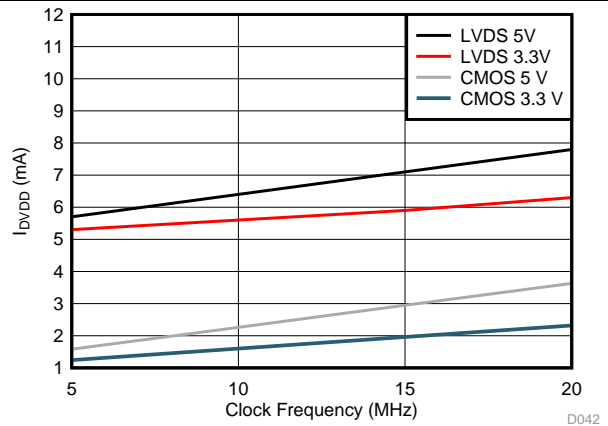

Figure 47. Controller-Side Supply Current vs Clock Frequency

8 Detailed Description

8.1 Overview

The differential analog input (AINP and AINN) of the AMC1305-Q1 is a fully-differential amplifier feeding the switched-capacitor input of a second-order delta-sigma ($\Delta\Sigma$) modulator stage that digitizes the input signal into a 1-bit output stream. The isolated data output (DOUT) of the converter provides a stream of digital ones and zeros synchronous to the externally-provided clock source at the CLKIN pin with a frequency in the range of 5 MHz to 20.1 MHz. The time average of this serial bit-stream output is proportional to the analog input voltage.

The *Functional Block Diagram* section shows a detailed block diagram of the AMC1305-Q1. The analog input range is tailored to directly accommodate a voltage drop across a shunt resistor used for current sensing. The SiO₂-based capacitive isolation barrier supports a high level of magnetic field immunity as described in the application report *ISO72x Digital Isolator Magnetic-Field Immunity* (SLLA181A), available for download at www.ti.com. The external clock input simplifies the synchronization of multiple current-sense channels on the system level. The extended frequency range of up to 20.1 MHz supports higher performance levels compared to other solutions available on the market.

8.2 Functional Block Diagram

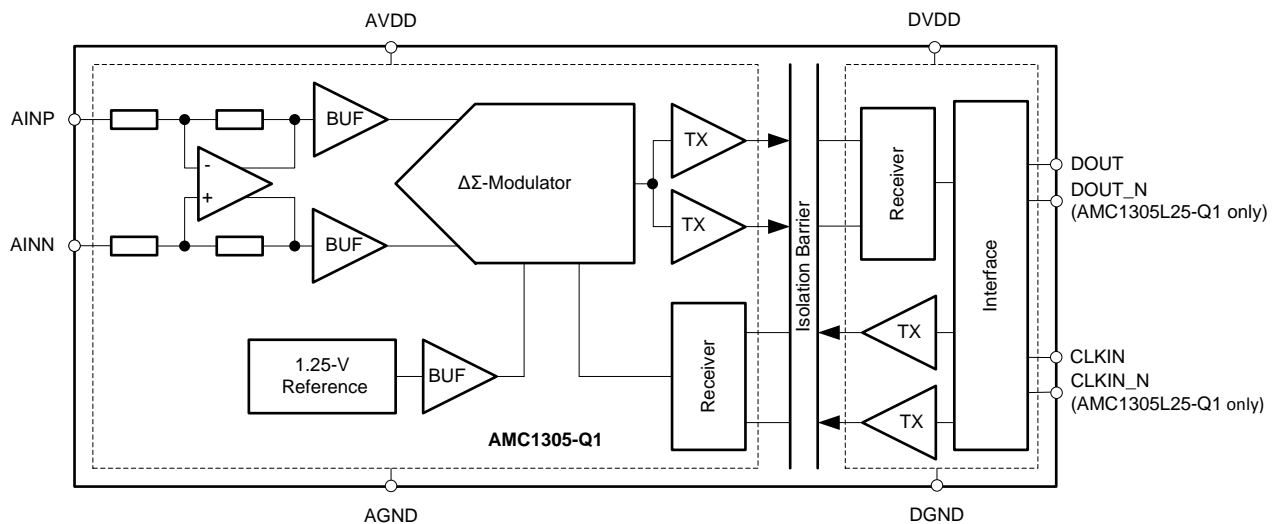

Copyright © 2016, Texas Instruments Incorporated

8.3 Feature Description

8.3.1 Analog Input

The AMC1305-Q1 incorporates front-end circuitry that contains a differential amplifier and sampling stage, followed by a $\Delta\Sigma$ modulator. The gain of the differential amplifier is set by internal precision resistors to a factor of 4 for devices with a specified input voltage range of ± 250 mV (for the AMC1305x25-Q1), or to a factor of 20 for devices with a ± 50 -mV input voltage range (for the AMC1305M05-Q1), resulting in a differential input impedance of 5 k Ω (for the AMC1305M05-Q1) or 25 k Ω (for the AMC1305x25-Q1).

Consider the input impedance of the AMC1305-Q1 in designs with high-impedance signal sources that can cause degradation of gain and offset specifications. The importance of this effect, however, depends on the desired system performance. Additionally, the input bias current caused by the internal common-mode voltage at the output of the differential amplifier causes an offset that depends on the actual amplitude of the input signal. See the [Isolated Voltage Sensing](#) section for more details on reducing these effects.

There are two restrictions on the analog input signals (AINP and AINN). First, if the input voltage exceeds the range of AGND – 6 V to AVDD + 0.5 V, the input current must be limited to 10 mA because the device input electrostatic discharge (ESD) protection diodes turn on. In addition, the linearity and noise performance of the device are ensured only when the differential analog input voltage remains within the specified linear full-scale range (FSR), that is ± 250 mV (for the AMC1305x25-Q1) or ± 50 mV (for the AMC1305M05-Q1), and within the specified input common-mode range.

8.3.2 Modulator

The modulator implemented in the AMC1305-Q1 is a second-order, switched-capacitor, feed-forward $\Delta\Sigma$ modulator, such as the one conceptualized in [Figure 48](#). The analog input voltage V_{IN} and the output V_5 of the 1-bit digital-to-analog converter (DAC) are differentiated, providing an analog voltage V_1 at the input of the first integrator stage. The output of the first integrator feeds the input of the second integrator stage, resulting in output voltage V_3 that is differentiated with the input signal V_{IN} and the output of the first integrator V_2 . Depending on the polarity of the resulting voltage V_4 , the output of the comparator is changed. In this case, the 1-bit DAC responds on the next clock pulse by changing its analog output voltage V_5 , causing the integrators to progress in the opposite direction while forcing the value of the integrator output to track the average value of the input.

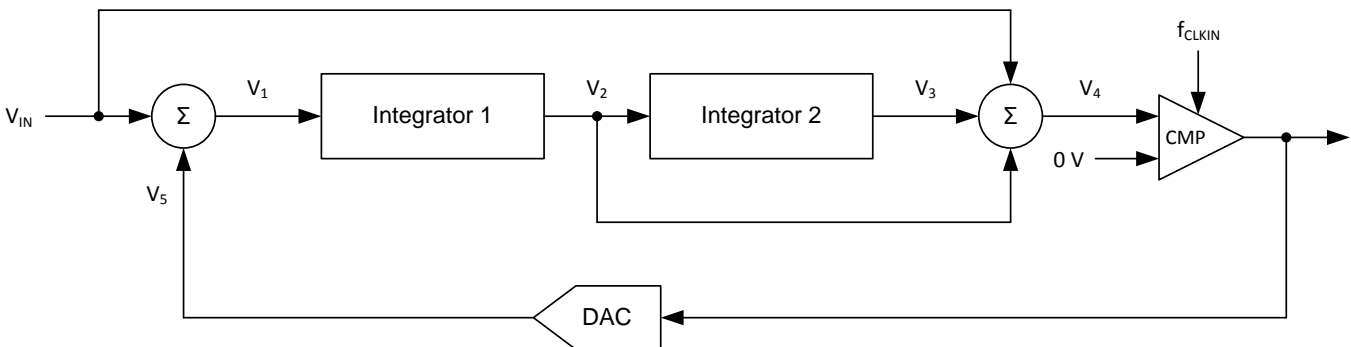

Figure 48. Block Diagram of a Second-Order Modulator

The modulator shifts the quantization noise to high frequencies; see [Figure 49](#). Therefore, use a low-pass digital filter at the output of the device to increase overall performance. This filter is also used to convert from the 1-bit data stream at a high sampling rate into a higher-bit data word at a lower rate (decimation). TI's microcontroller family [TMS320F2837x](#) offers a suitable programmable, hardwired filter structure termed a *sigma-delta filter module* (SDFM) optimized for usage with the AMC1305-Q1 family. Alternatively, a field-programmable gate array (FPGA) can be used to implement the digital filter.

Feature Description (continued)

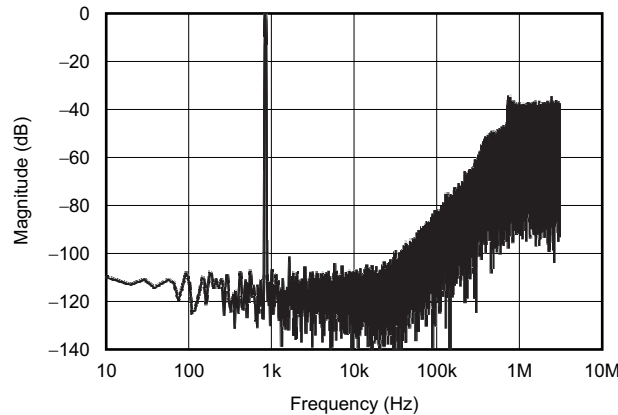

Figure 49. Quantization Noise Shaping

8.3.3 Digital Output

A differential input signal of 0 V ideally produces a stream of ones and zeros that are high 50% of the time. A differential input of 250 mV (for the AMC1305x25-Q1) or 50 mV (for the AMC1305M05-Q1) produces a stream of ones and zeros that are high 90% of the time. A differential input of –250 mV (–50 mV for the AMC1305M05-Q1) produces a stream of ones and zeros that are high 10% of the time. These input voltages are also the specified linear ranges of the different AMC1305-Q1 versions with performance as specified in this document. If the input voltage value exceeds these ranges, the output of the modulator shows non-linear behavior while the quantization noise increases. The output of the modulator would clip with a stream of only zeros with an input less than or equal to –312.5 mV (–62.5 mV for the AMC1305M05-Q1) or with a stream of only ones with an input greater than or equal to 312.5 mV (62.5 mV for the AMC1305M05-Q1). In this case, however, the AMC1305-Q1 generates a single 1 (if the input is at negative full-scale) or 0 every 128 clock cycles to indicate proper device function (see the [Fail-Safe Output](#) section for more details). The input voltage versus the output modulator signal is shown in [Figure 50](#).

The density of ones in the output bit-stream for any input voltage value (with the exception of a full-scale input signal as described in [Output Behavior in Case of Full-Scale Input](#)) can be calculated using [Equation 1](#):

$$\frac{V_{IN} + V_{Clipping}}{2 * V_{Clipping}} \tag{1}$$

The AMC1305-Q1 system clock is typically 20 MHz and is provided externally at the CLKIN pin. Data are synchronously provided at 20 MHz at the DOUT pin. Data change at the CLKIN falling edge. For more details, see the [Switching Characteristics](#) table.

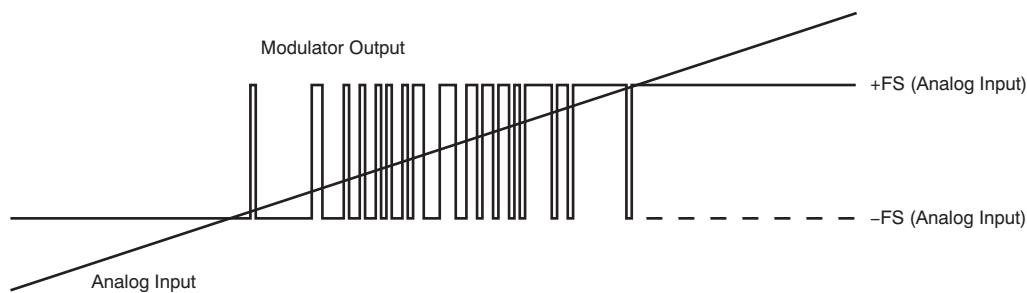

Figure 50. Analog Input versus AMC1305-Q1 Modulator Output

8.4 Device Functional Modes

8.4.1 Fail-Safe Output

In the case of a missing high-side supply voltage (AVDD), the output of a $\Delta\Sigma$ modulator is not defined and could cause a system malfunction. In systems with high safety requirements, this behavior is not acceptable. Therefore, the AMC1305-Q1 implements a fail-safe output function that ensures the device maintains its output level in case of a missing AVDD, as shown in Figure 51.

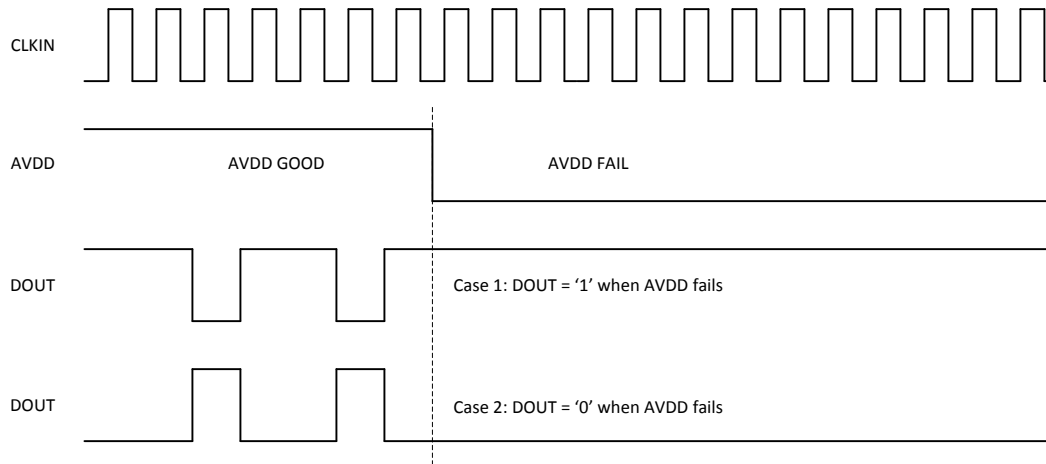

Figure 51. Fail-Safe Output of the AMC1305-Q1

8.4.2 Output Behavior in Case of Full-Scale Input

If a full-scale input signal is applied to the AMC1305-Q1 (that is, $V_{IN} \geq V_{Clipping}$), the device generates a single one or zero every 128 bits at DOUT, depending on the actual polarity of the signal being sensed, as shown in Figure 52.

In this way, differentiating between a missing AVDD and a full-scale input signal is possible on the system level.

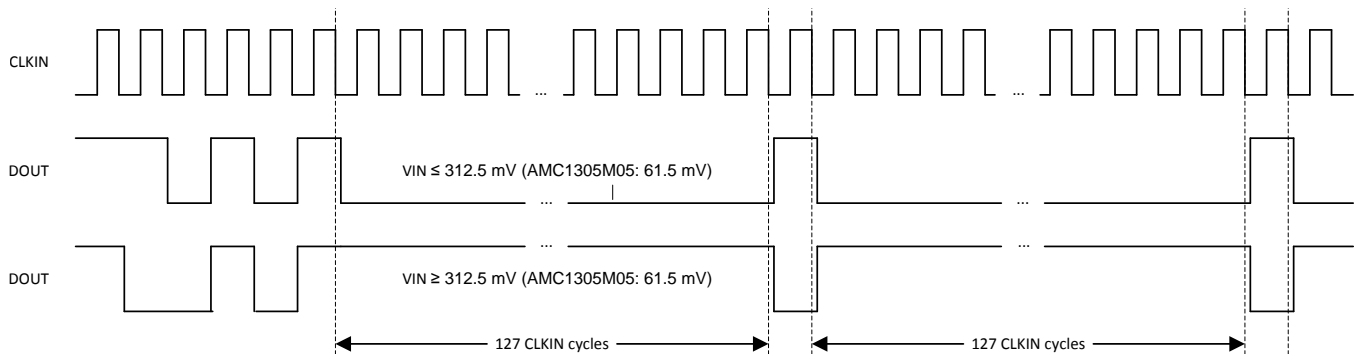

Figure 52. Overage Output of the AMC1305-Q1

9 Application and Implementation

NOTE

Information in the following applications sections is not part of the TI component specification, and TI does not warrant its accuracy or completeness. TI's customers are responsible for determining suitability of components for their purposes. Customers should validate and test their design implementation to confirm system functionality.

9.1 Application Information

9.1.1 Digital Filter Usage

The modulator generates a bit stream that is processed by a digital filter to obtain a digital word similar to a conversion result of a conventional analog-to-digital converter (ADC). A very simple filter, built with minimal effort and hardware, is a sinc³-type filter, as shown in [Equation 2](#):

$$H(z) = \left(\frac{1 - z^{-OSR}}{1 - z^{-1}} \right)^3 \quad (2)$$

This filter provides the best output performance at the lowest hardware size (count of digital gates) for a second-order modulator. All the characterization in this document is also done with a sinc³ filter with an over-sampling ratio (OSR) of 256 and an output word width of 16 bits.

$$SNR = 1.76dB + 6.02dB * ENOB \quad (3)$$

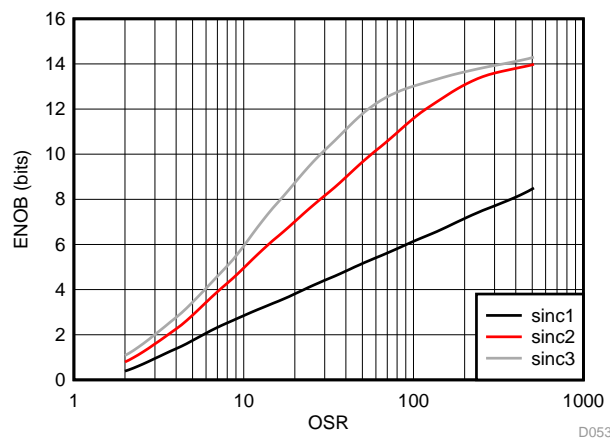

Figure 53. Measured Effective Number of Bits versus Oversampling Ratio

An example code for an implementation of a sinc³ filter in an FPGA, see the application note [Combining ADS1202 with FPGA Digital Filter for Current Measurement in Motor Control Applications \(SBAA094\)](#), available for download at www.ti.com.

9.2 Typical Applications

9.2.1 Traction Inverter Application

Because to their high ac and dc performance, isolated $\Delta\Sigma$ modulators are being widely used in new generation traction inverter designs. Traction inverters are critical parts of electrical and hybrid electrical vehicles. The input structure of the AMC1305-Q1 is optimized for use with low-impedance shunt resistors and is therefore tailored for isolated current sensing using shunts.

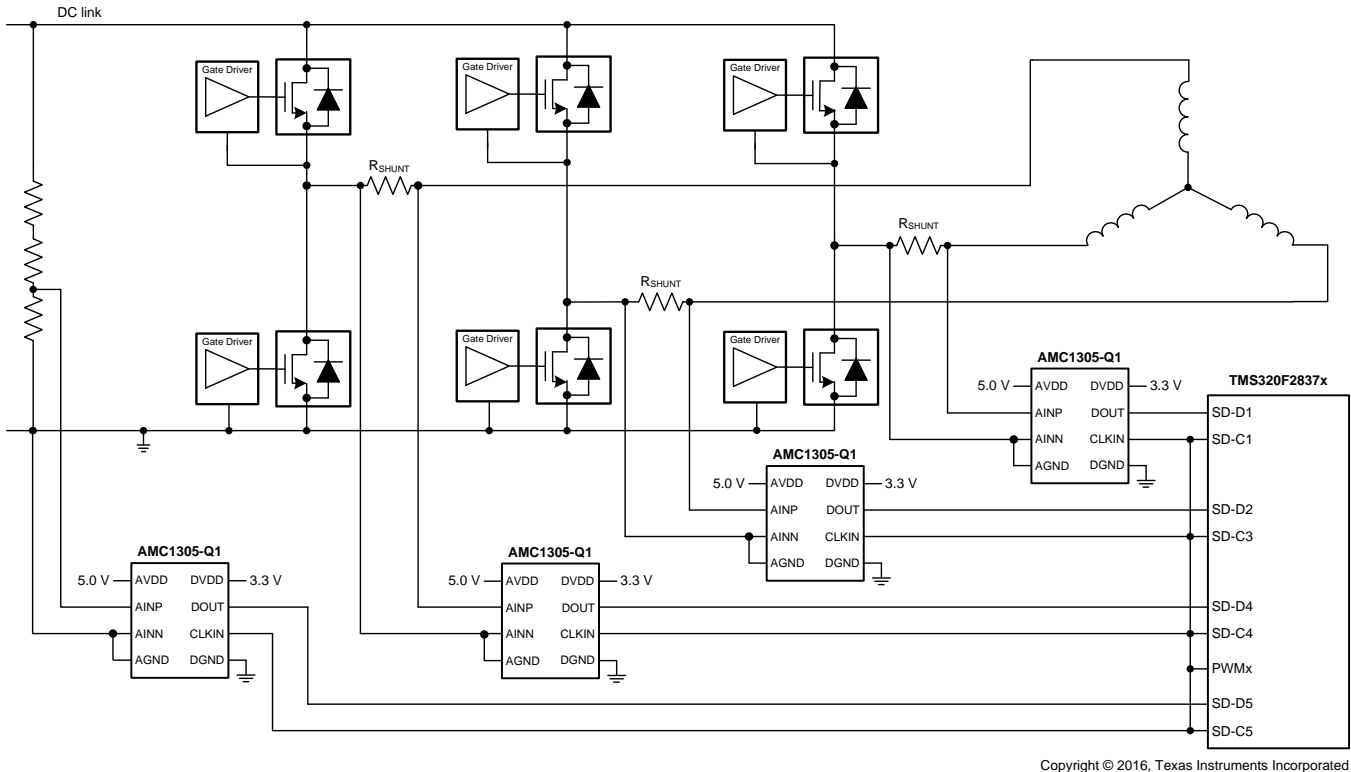

Copyright © 2016, Texas Instruments Incorporated

Figure 54. The AMC1305-Q1 in a Traction Inverter Application

9.2.1.1 Design Requirements

A typical operation of the device in a traction inverter application is shown in Figure 54. When the inverter stage is part of a motor drive system, measurement of the motor phase current is done via the shunt resistors (R_{SHUNT}). Depending on the system design, either all three or only two phase currents are sensed.

In this example, an additional fourth AMC1305-Q1 is used to support isolated voltage sensing of the dc link. This high voltage is reduced using a high-impedance resistive divider before being sensed by the device across a smaller resistor. The value of this resistor can degrade the performance of the measurement, as described in the [Isolated Voltage Sensing](#) section.

9.2.1.2 Detailed Design Procedure

The usually recommended RC filter in front of a $\Delta\Sigma$ modulator to improve signal-to-noise performance of the signal path, is not required for the AMC1305-Q1. By design, the input bandwidth of the analog front-end of the device is limited to 1 MHz.

For modulator output bit-stream filtering, a device from TI's [TMS320F2837x](#) family of dual-core MCUs is recommended. This family supports up to eight channels of dedicated hardwired filter structures that significantly simplify system level design by offering two filtering paths per channel: one providing high accuracy results for the control loop and one fast response path for overcurrent detection.

Typical Applications (continued)

9.2.1.3 Application Curve

In motor control applications, a very fast response time for overcurrent detection is required. The time for fully settling the filter in case of a step-signal at the input of the modulator depends on its order; that is, a sinc³ filter requires three data updates for full settling (with $f_{DATA} = f_{CLK} / OSR$). Therefore, for overcurrent protection, filter types other than sinc³ can be a better choice; an alternative is the sinc² filter. Figure 55 compares the settling times of different filter orders.

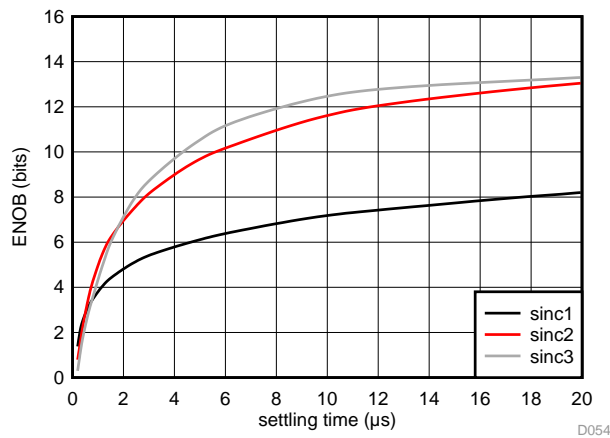

Figure 55. Measured Effective Number of Bits versus Settling Time

The delay time of the sinc filter with a continuous signal is half of its settling time.

Typical Applications (continued)

9.2.2 Isolated Voltage Sensing

The AMC1305-Q1 is optimized for usage in current-sensing applications using low-impedance shunts. However, the device can also be used in isolated voltage-sensing applications if the impact of the (usually higher) impedance of the resistor used in this case is considered.

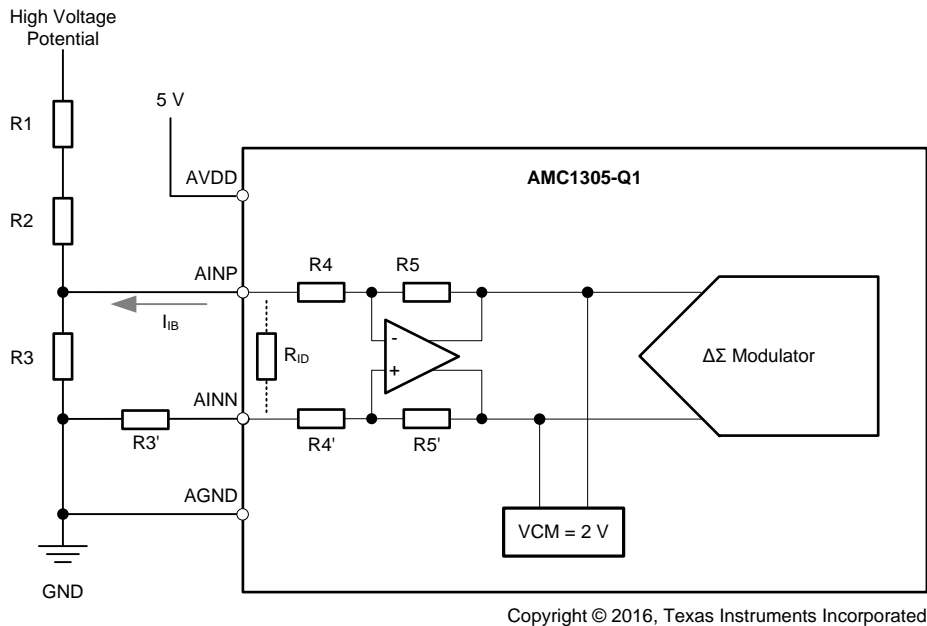

Figure 56. Using AMC1305-Q1 for Isolated Voltage Sensing

9.2.2.1 Design Requirements

Figure 56 shows a simplified circuit typically used in high-voltage sensing applications. The high impedance resistors (R1 and R2) are used as voltage dividers and dominate the current value definition. The resistance of the sensing resistor R3 is chosen to meet the input voltage range of the AMC1305-Q1. This resistor and the differential input impedance of the device (the AMC1305x25-Q1 is 25 kΩ, the AMC1305M05-Q1 is 5 kΩ) also create a voltage divider that results in an additional gain error. With the assumption of R1, R2, and R_{IN} having a considerably higher value than R3, the resulting total gain error can be estimated using Equation 4, with E_G being the gain error of the AMC1305-Q1.

$$|E_{G_{tot}}| = |E_G| + \frac{R_3}{R_{IN}} \quad (4)$$

This gain error can be easily minimized during the initial system level gain calibration procedure.

9.2.2.2 Detailed Design Procedure

As indicated in Figure 56, the output of the integrated differential amplifier is internally biased to a common-mode voltage of 2 V. This voltage results in a bias current I_{IB} through the resistive network R4 and R5 (or R4' and R5') used for setting the gain of the amplifier. The value range of this current is specified in the Electrical Characteristics table. This bias current generates additional offset error that depends on the value of the resistor R3. Because the value of this bias current depends on the actual common-mode amplitude of the input signal (as shown in Figure 57), the initial system offset calibration does not minimize its effect. Therefore, in systems with high accuracy requirements TI recommends using a series resistor at the negative input (AINN) of the AMC1305-Q1 with a value equal to the shunt resistor R3 (that is R3' = R3 in Figure 56) to eliminate the effect of the bias current.

Typical Applications (continued)

This additional series resistor ($R3'$) influences the gain error of the circuit. The effect can be calculated using Equation 5 with $R5 = R5' = 50 \text{ k}\Omega$ and $R4 = R4' = 2.5 \text{ k}\Omega$ (for the AMC1305M05-Q1) or $12.5 \text{ k}\Omega$ (for the AMC1305x25-Q1).

$$E_G(\%) = \left(1 - \frac{R4}{R4' + R3'} \right) * 100\% \quad (5)$$

9.2.2.3 Application Curve

Figure 57 shows the dependency of the input bias current on the common-mode voltage at the input of the AMC1305-Q1.

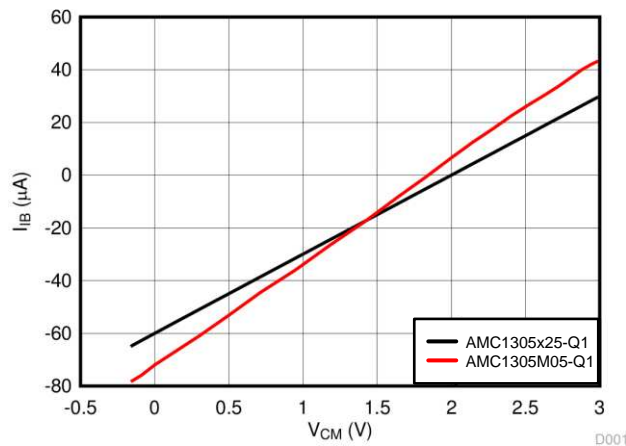

Figure 57. Input Current vs Input Common-Mode Voltage

10 Power-Supply Recommendations

In a typical traction inverter application, the high-side power supply (AVDD) for the device is derived from the floating power supply of the upper gate driver. For lowest cost, a Zener diode can be used to limit the voltage to $5\text{ V} \pm 10\%$. Alternatively a low-cost low-drop regulator (LDO), for example the [LP2951-xx-Q1](#), can be used to minimize noise on the power supply. A low-ESR decoupling capacitor of $0.1\ \mu\text{F}$ is recommended for filtering this power-supply path. Place this capacitor (C_2 in [Figure 58](#)) as close as possible to the AVDD pin of the AMC1305-Q1 for best performance. If better filtering is required, an additional $10\text{-}\mu\text{F}$ capacitor can be used. The floating ground reference (AGND) is derived from the end of the shunt resistor, which is connected to the negative input (AINN) of the device. If a four-pin shunt is used, the device inputs are connected to the inner leads, while AGND is connected to one of the outer leads of the shunt.

For decoupling of the digital power supply on controller side, TI recommends using a $0.1\text{-}\mu\text{F}$ capacitor assembled as close to the DVDD pin of the AMC1305-Q1 as possible, followed by an additional capacitor in the range of $1\ \mu\text{F}$ to $10\ \mu\text{F}$.

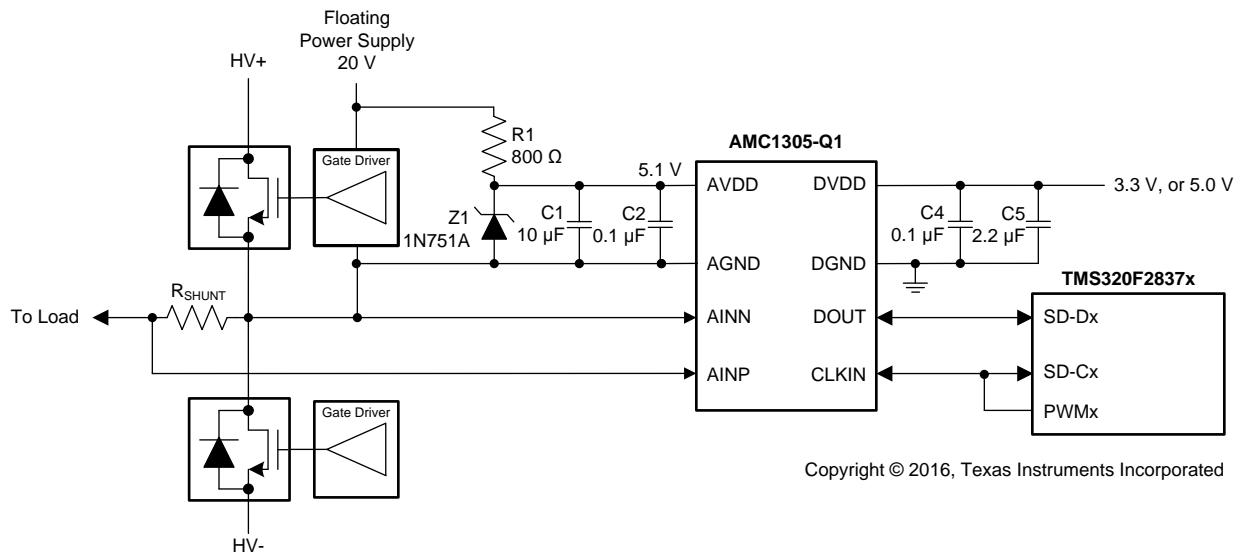

Figure 58. Zener-Diode-Based High-Side Power Supply

11 Layout

11.1 Layout Guidelines

A layout recommendation showing the critical placement of the decoupling capacitors (as close as possible to the AMC1305-Q1) and placement of the other components required by the device is shown in Figure 59.

For the AMC1305L25-Q1 version, place the 100-Ω termination resistor as close as possible to the CLKIN, CLKIN_N inputs of the device to achieve highest signal integrity. If not integrated, an additional termination resistor is required as close as possible to the LVDS data inputs of the MCU or filter device; see Figure 60.

11.2 Layout Examples

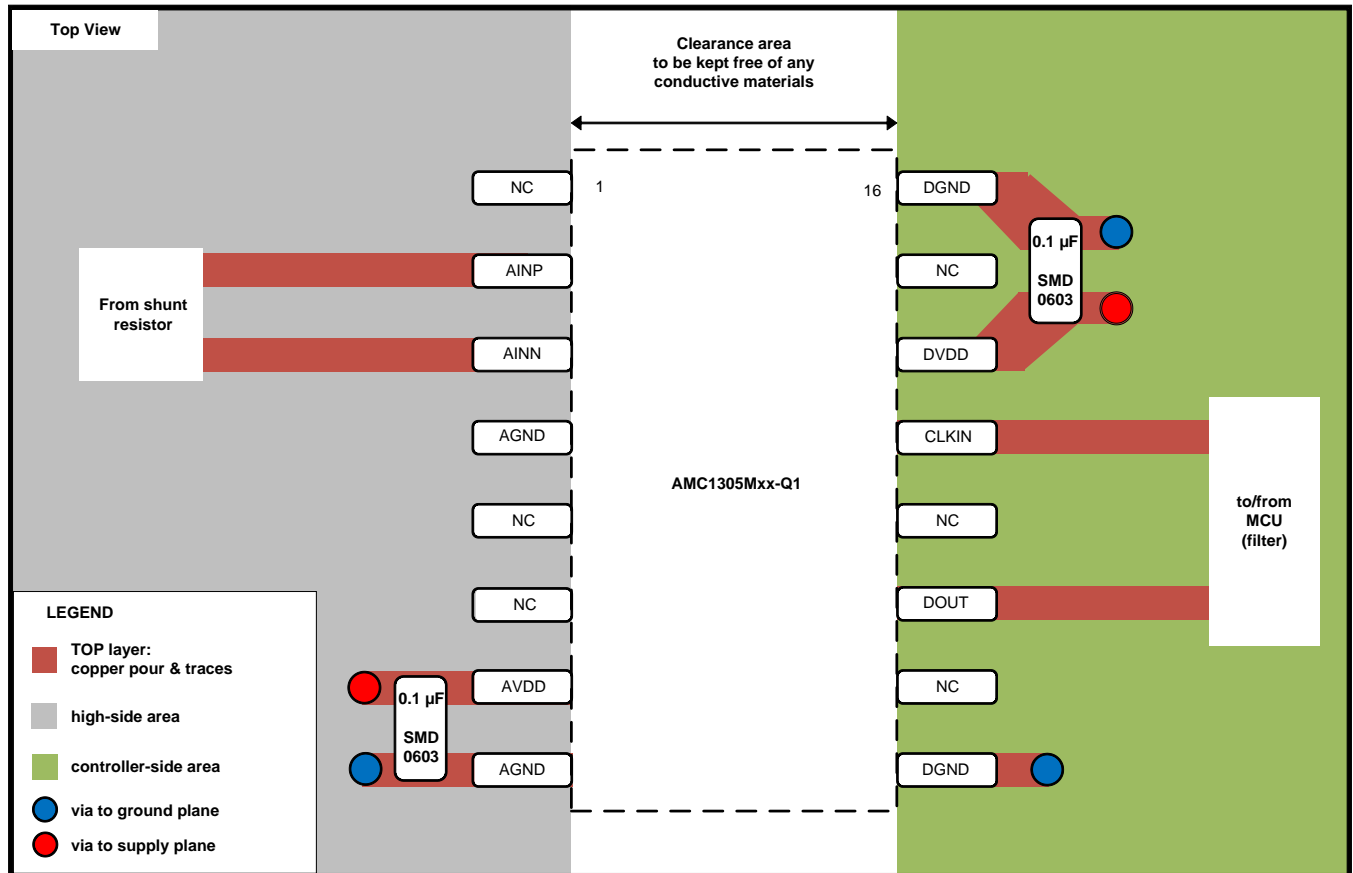

Copyright © 2016, Texas Instruments Incorporated

Figure 59. Recommended Layout of the AMC1305Mxx-Q1

Layout Examples (continued)

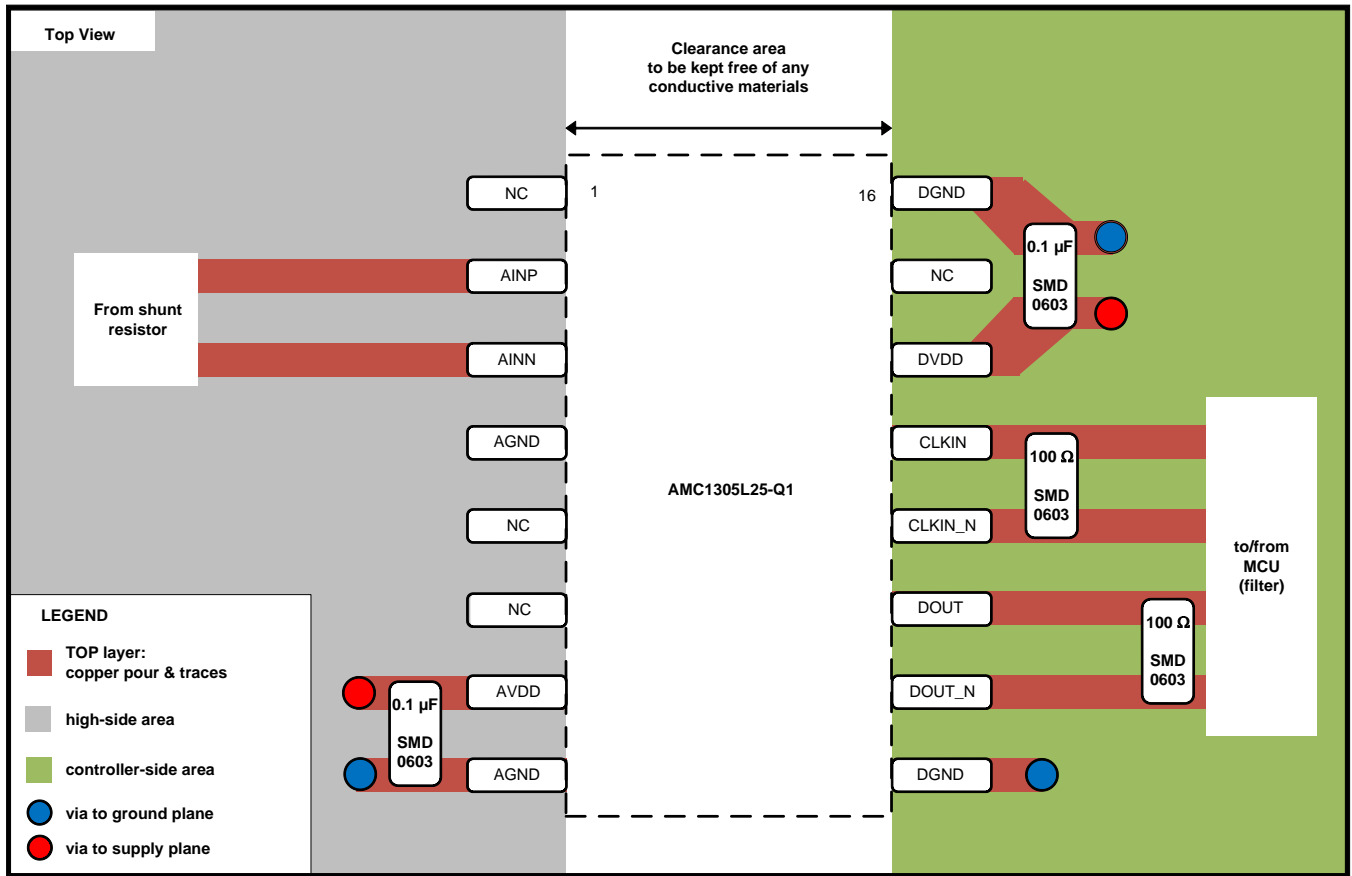

Copyright © 2016, Texas Instruments Incorporated

Figure 60. Recommended Layout of the AMC1305L25-Q1

12 器件和文档支持

12.1 文档支持

12.1.1 相关文档

相关文档请参阅以下部分：

- [隔离相关术语](#)
- [《ISO72x 数字隔离器磁场抗扰度》](#)
- [《使用 ADS1202 与 FPGA 数字滤波器的组合测量 测量》](#)
- [《LP2951-xx-Q1 具有关断功能的可调节低功耗稳压器》](#)
- [《TMS320F2837xD 双核 Delfino™ 微控制器》](#)

12.2 相关链接

下面的表格列出了快速访问链接。范围包括技术文档、支持与社区资源、工具和软件，并且可通过快速访问立刻订购。

表 1. 相关链接

器件	产品文件夹	立即订购	技术文档	工具与软件	支持与社区
AMC1305L25-Q1	请单击此处	请单击此处	请单击此处	请单击此处	请单击此处
AMC1305M05-Q1	请单击此处	请单击此处	请单击此处	请单击此处	请单击此处
AMC1305M25-Q1	请单击此处	请单击此处	请单击此处	请单击此处	请单击此处

12.3 接收文档更新通知

如需接收文档更新通知，请访问 www.ti.com.cn 网站上的器件产品文件夹。点击右上角的**提醒我 (Alert me)** 注册后，即可每周定期收到已更改的产品信息。有关更改的详细信息，请查阅已修订文档中包含的修订历史记录。

12.4 社区资源

The following links connect to TI community resources. Linked contents are provided "AS IS" by the respective contributors. They do not constitute TI specifications and do not necessarily reflect TI's views; see TI's [Terms of Use](#).

TI E2E™ Online Community *TI's Engineer-to-Engineer (E2E) Community*. Created to foster collaboration among engineers. At e2e.ti.com, you can ask questions, share knowledge, explore ideas and help solve problems with fellow engineers.

Design Support *TI's Design Support* Quickly find helpful E2E forums along with design support tools and contact information for technical support.

12.5 商标

E2E is a trademark of Texas Instruments.

All other trademarks are the property of their respective owners.

12.6 静电放电警告



ESD 可能会损坏该集成电路。德州仪器 (TI) 建议通过适当的预防措施处理所有集成电路。如果不遵守正确的处理措施和安装程序，可能会损坏集成电路。

ESD 的损坏小至导致微小的性能降级，大至整个器件故障。精密的集成电路可能更容易受到损坏，这是因为非常细微的参数更改都可能会导致器件与其发布的规格不相符。

12.7 Glossary

[SLYZ022](#) — *TI Glossary*.

This glossary lists and explains terms, acronyms, and definitions.

13 机械、封装和可订购信息

以下页中包括机械、封装和可订购信息。这些信息是针对指定器件可提供的最新数据。这些数据会在无通知且不对本文档进行修订的情况下发生改变。欲获得该数据表的浏览器版本，请查阅左侧的导航栏。

PACKAGING INFORMATION

Orderable Device	Status (1)	Package Type	Package Drawing	Pins	Package Qty	Eco Plan (2)	Lead finish/ Ball material (6)	MSL Peak Temp (3)	Op Temp (°C)	Device Marking (4/5)	Samples
AMC1305L25QDWQ1	ACTIVE	SOIC	DW	16	40	RoHS & Green	NIPDAU	Level-3-260C-168 HR	-40 to 125	1305L25Q1	Samples
AMC1305L25QDWRQ1	ACTIVE	SOIC	DW	16	2000	RoHS & Green	NIPDAU	Level-3-260C-168 HR	-40 to 125	1305L25Q1	Samples
AMC1305M05QDWQ1	ACTIVE	SOIC	DW	16	40	RoHS & Green	NIPDAU	Level-3-260C-168 HR	-40 to 125	1305M05Q1	Samples
AMC1305M05QDWRQ1	ACTIVE	SOIC	DW	16	2000	RoHS & Green	NIPDAU	Level-3-260C-168 HR	-40 to 125	1305M05Q1	Samples
AMC1305M25QDWQ1	ACTIVE	SOIC	DW	16	40	RoHS & Green	NIPDAU	Level-3-260C-168 HR	-40 to 125	1305M25Q1	Samples
AMC1305M25QDWRQ1	ACTIVE	SOIC	DW	16	2000	RoHS & Green	NIPDAU	Level-3-260C-168 HR	-40 to 125	1305M25Q1	Samples

(1) The marketing status values are defined as follows:

ACTIVE: Product device recommended for new designs.

LIFEBUY: TI has announced that the device will be discontinued, and a lifetime-buy period is in effect.

NRND: Not recommended for new designs. Device is in production to support existing customers, but TI does not recommend using this part in a new design.

PREVIEW: Device has been announced but is not in production. Samples may or may not be available.

OBSOLETE: TI has discontinued the production of the device.

(2) **RoHS:** TI defines "RoHS" to mean semiconductor products that are compliant with the current EU RoHS requirements for all 10 RoHS substances, including the requirement that RoHS substance do not exceed 0.1% by weight in homogeneous materials. Where designed to be soldered at high temperatures, "RoHS" products are suitable for use in specified lead-free processes. TI may reference these types of products as "Pb-Free".

RoHS Exempt: TI defines "RoHS Exempt" to mean products that contain lead but are compliant with EU RoHS pursuant to a specific EU RoHS exemption.

Green: TI defines "Green" to mean the content of Chlorine (Cl) and Bromine (Br) based flame retardants meet JS709B low halogen requirements of <=1000ppm threshold. Antimony trioxide based flame retardants must also meet the <=1000ppm threshold requirement.

(3) MSL, Peak Temp. - The Moisture Sensitivity Level rating according to the JEDEC industry standard classifications, and peak solder temperature.

(4) There may be additional marking, which relates to the logo, the lot trace code information, or the environmental category on the device.

(5) Multiple Device Markings will be inside parentheses. Only one Device Marking contained in parentheses and separated by a "~" will appear on a device. If a line is indented then it is a continuation of the previous line and the two combined represent the entire Device Marking for that device.

(6) Lead finish/Ball material - Orderable Devices may have multiple material finish options. Finish options are separated by a vertical ruled line. Lead finish/Ball material values may wrap to two lines if the finish value exceeds the maximum column width.

Important Information and Disclaimer: The information provided on this page represents TI's knowledge and belief as of the date that it is provided. TI bases its knowledge and belief on information provided by third parties, and makes no representation or warranty as to the accuracy of such information. Efforts are underway to better integrate information from third parties. TI has taken and continues to take reasonable steps to provide representative and accurate information but may not have conducted destructive testing or chemical analysis on incoming materials and chemicals. TI and TI suppliers consider certain information to be proprietary, and thus CAS numbers and other limited information may not be available for release.

In no event shall TI's liability arising out of such information exceed the total purchase price of the TI part(s) at issue in this document sold by TI to Customer on an annual basis.

GENERIC PACKAGE VIEW

DW 16

SOIC - 2.65 mm max height

7.5 x 10.3, 1.27 mm pitch

SMALL OUTLINE INTEGRATED CIRCUIT

This image is a representation of the package family, actual package may vary.
Refer to the product data sheet for package details.

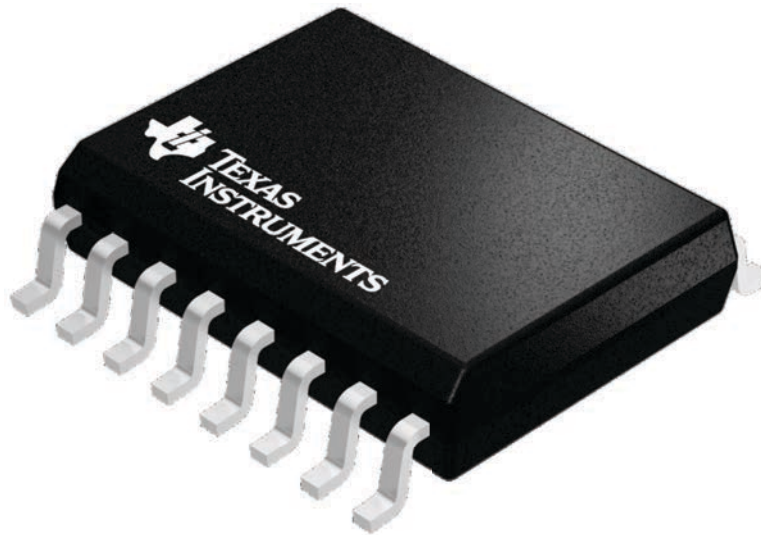

4224780/A



DW0016A

PACKAGE OUTLINE

SOIC - 2.65 mm max height

SOIC

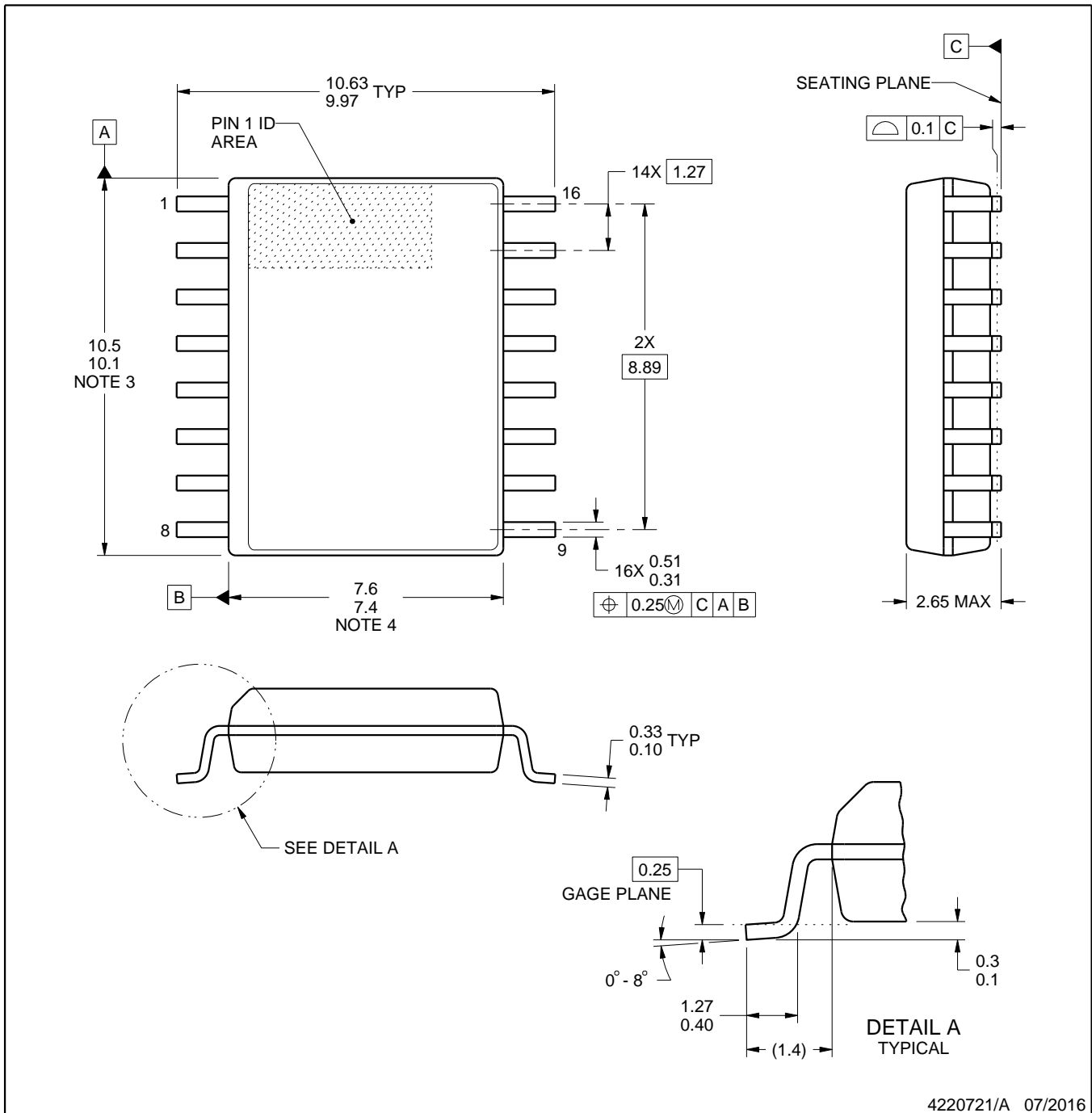

4220721/A 07/2016

NOTES:

1. All linear dimensions are in millimeters. Dimensions in parenthesis are for reference only. Dimensioning and tolerancing per ASME Y14.5M.
2. This drawing is subject to change without notice.
3. This dimension does not include mold flash, protrusions, or gate burrs. Mold flash, protrusions, or gate burrs shall not exceed 0.15 mm, per side.
4. This dimension does not include interlead flash. Interlead flash shall not exceed 0.25 mm, per side.
5. Reference JEDEC registration MS-013.

EXAMPLE STENCIL DESIGN

DW0016A

SOIC - 2.65 mm max height

SOIC

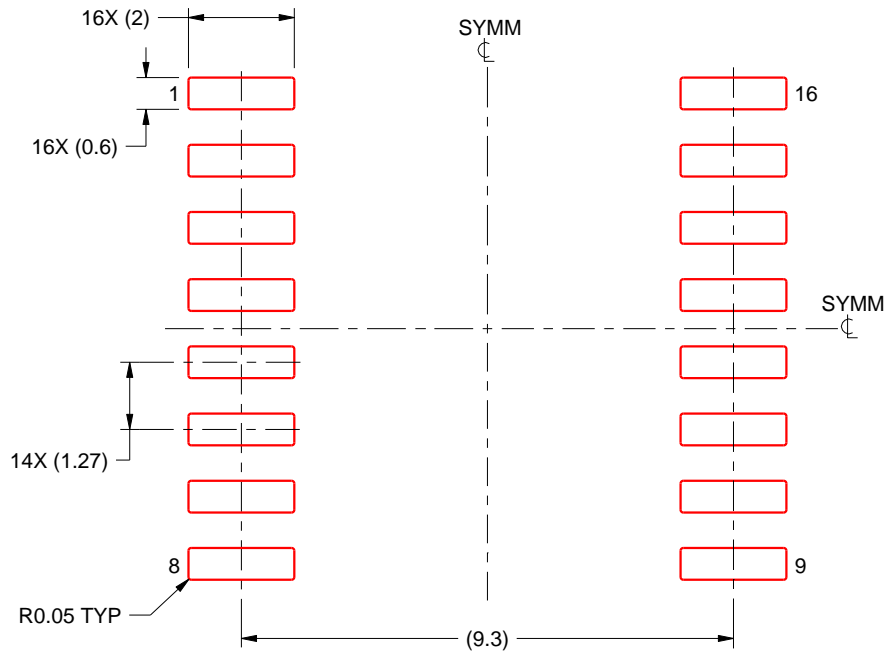

SOLDER PASTE EXAMPLE
BASED ON 0.125 mm THICK STENCIL
SCALE:7X

4220721/A 07/2016

NOTES: (continued)

8. Laser cutting apertures with trapezoidal walls and rounded corners may offer better paste release. IPC-7525 may have alternate design recommendations.
9. Board assembly site may have different recommendations for stencil design.



DW0016B

PACKAGE OUTLINE

SOIC - 2.65 mm max height

SOIC

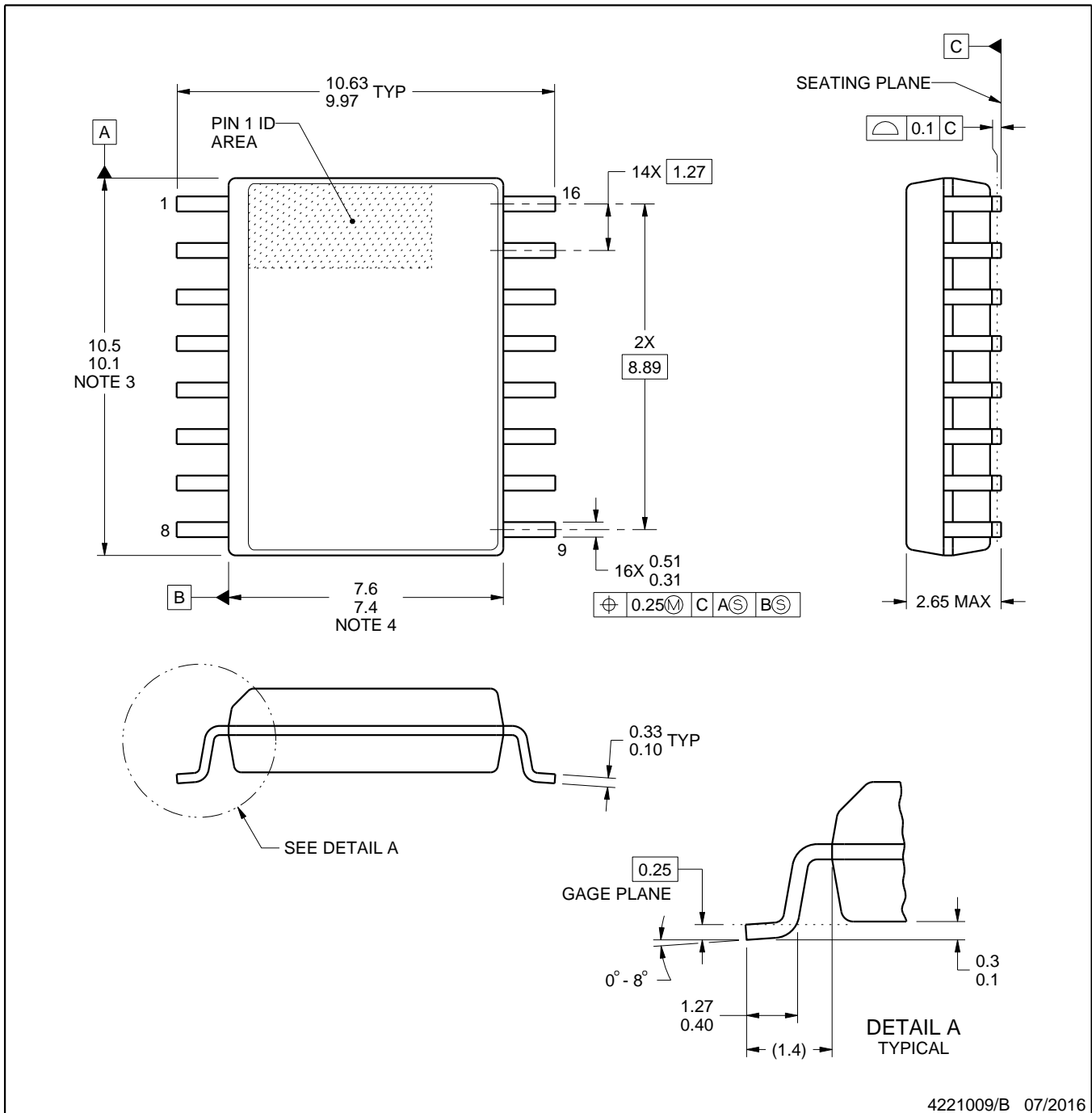

4221009/B 07/2016

NOTES:

1. All linear dimensions are in millimeters. Dimensions in parenthesis are for reference only. Dimensioning and tolerancing per ASME Y14.5M.
2. This drawing is subject to change without notice.
3. This dimension does not include mold flash, protrusions, or gate burrs. Mold flash, protrusions, or gate burrs shall not exceed 0.15 mm, per side.
4. This dimension does not include interlead flash. Interlead flash shall not exceed 0.25 mm, per side.
5. Reference JEDEC registration MS-013.

EXAMPLE BOARD LAYOUT

DW0016B

SOIC - 2.65 mm max height

SOIC

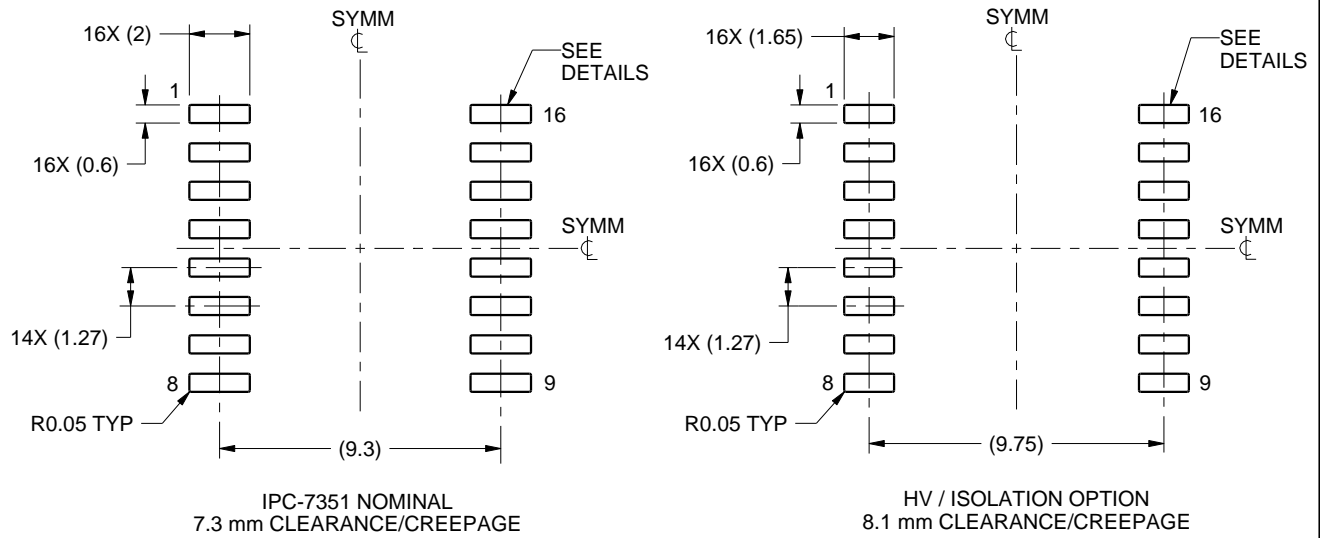

LAND PATTERN EXAMPLE
SCALE:4X

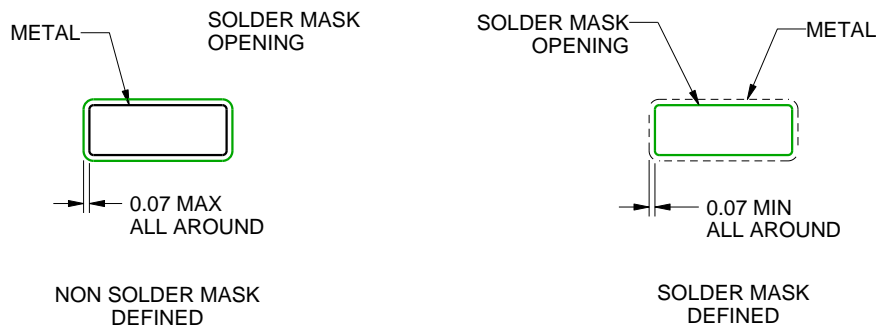

SOLDER MASK DETAILS

4221009/B 07/2016

NOTES: (continued)

- 6. Publication IPC-7351 may have alternate designs.
- 7. Solder mask tolerances between and around signal pads can vary based on board fabrication site.

EXAMPLE STENCIL DESIGN

DW0016B

SOIC - 2.65 mm max height

SOIC

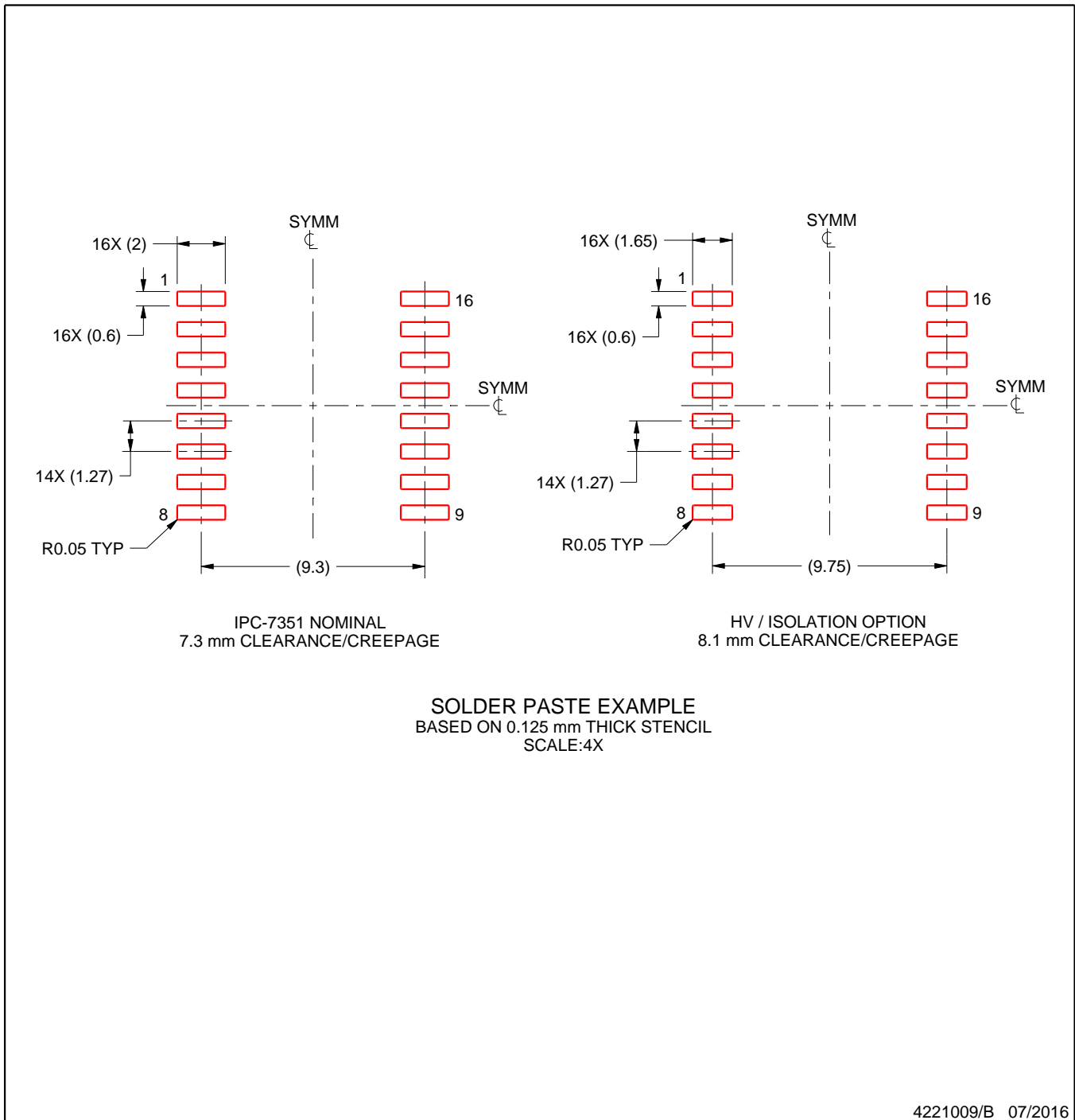

NOTES: (continued)

8. Laser cutting apertures with trapezoidal walls and rounded corners may offer better paste release. IPC-7525 may have alternate design recommendations.
9. Board assembly site may have different recommendations for stencil design.

重要声明和免责声明

TI 提供技术和可靠性数据（包括数据表）、设计资源（包括参考设计）、应用或其他设计建议、网络工具、安全信息和其他资源，不保证没有瑕疵且不做任何明示或暗示的担保，包括但不限于对适销性、某特定用途方面的适用性或不侵犯任何第三方知识产权的暗示担保。

这些资源可供使用 TI 产品进行设计的熟练开发人员使用。您将自行承担以下全部责任：(1) 针对您的应用选择合适的 TI 产品，(2) 设计、验证并测试您的应用，(3) 确保您的应用满足相应标准以及任何其他安全、安保或其他要求。这些资源如有变更，恕不另行通知。TI 授权您仅可将这些资源用于研发本资源所述的 TI 产品的应用。严禁对这些资源进行其他复制或展示。您无权使用任何其他 TI 知识产权或任何第三方知识产权。您应全额赔偿因在这些资源的使用中对 TI 及其代表造成的任何索赔、损害、成本、损失和债务，TI 对此概不负责。

TI 提供的产品受 TI 的销售条款 (<https://www.ti.com.cn/zh-cn/legal/termsofsale.html>) 或 [ti.com.cn](https://www.ti.com.cn) 上其他适用条款/TI 产品随附的其他适用条款的约束。TI 提供这些资源并不会扩展或以其他方式更改 TI 针对 TI 产品发布的适用的担保或担保免责声明。

邮寄地址：上海市浦东新区世纪大道 1568 号中建大厦 32 楼，邮政编码：200122
Copyright © 2021 德州仪器半导体技术（上海）有限公司