

# 具有 5V 和 3.3V 低压降稳压器 (LDO) 的超低静态 (ULQ™) 双通道同步降压控制器

查询样品: **TPS51285A, TPS51285B**

## 特性

- 输入电压范围: **5V 至 24V**
- 输出电压: **5V 和 3.3V** (可调范围  $\pm 10\%$ )
- 内置, **100mA, 5V 和 3.3V LDO**
- 用于电荷泵的时钟输出
- **$\pm 1\%$  基准精度**
- 自适应接通时间 **D-CAP™** 模式控制架构, 此架构的频率为 **400kHz** (通道 1) 和 **475kHz** (通道 2)
- 自动跳跃和 **ULQ™** 模式, 这些模式用于在系统待机模式中实现较长的电池使用寿命
- 内部 **0.8ms** 电压伺服器软启动
- 低侧 **R<sub>DS</sub>** (导通) 电流感应机制
- 内置输出放电功能
- 用于开关的独立使能输入
- 专用 **OC** 设置端子
- 电源正常指示器
- 过压 (**OVP**), 欠压 (**UVP**) 和过流 (**OCP**) 保护
- 非锁存欠压闭锁 (**UVLO**) 和过热 (**OTP**) 保护
- **20** 引脚, **3mm x 3mm**, 四方扁平无引线 (**QFN**)(**RUK**) 封装

## 应用范围

- 笔记本电脑
- 平板电脑

## 说明

TPS51285A 和 TPS51285B 是具有 5V 和 3.3V LDO 的成本有效双通道同步降压控制器, 此控制器针对笔记本电脑系统电源解决方案。此器件通过使用自动跳跃和 ULQ™ 模式来实现低功耗, 这有利于延长系统待机模式下的电池使用寿命。提供了 256kHz VCLK 输出以驱动一个外部电荷泵, 从而在主转换器中以最低功耗为负载开关生成栅极驱动电压。此器件采用自适应接通时间 D-CAP™ 模式控制, 从而在无需外部补偿网络的情况下实现快速负载瞬态响应。TPS51285A/B 运行电源输入电压范围介于 5V 至 24V 之间并且支持 5V 和 3.3V 的输出电压。TPS51285A 和 TPS51285B 采用 20 引脚, 3mm x 3mm, QFN 封装, 额定运行温度 -40°C 至 85°C。

## 订购信息<sup>(1)</sup>

可订购的器件号	常开模式 - LDO	输出电源	数量
TPS51285ARUKR	VREG3	卷带封装	3000
TPS51285ARUKT		小型卷带	250
TPS51285BRUKR	VREG3 和 VREG5	卷带封装	3000
TPS51285BRUKT		小型卷带	250

(1) 要获得最新的封装和订购信息, 请见本文档末尾的封装选项附录, 或者访问德州仪器 (TI) 的网站 [www.ti.com](http://www.ti.com)。



Please be aware that an important notice concerning availability, standard warranty, and use in critical applications of Texas Instruments semiconductor products and disclaimers thereto appears at the end of this data sheet.

D-CAP, ULQ are trademarks of Texas Instruments.

PRODUCTION DATA information is current as of publication date. Products conform to specifications per the terms of the Texas Instruments standard warranty. Production processing does not necessarily include testing of all parameters.

Copyright © 2013, Texas Instruments Incorporated  
English Data Sheet: **SLVSBX0**



These devices have limited built-in ESD protection. The leads should be shorted together or the device placed in conductive foam during storage or handling to prevent electrostatic damage to the MOS gates.

### TYPICAL APPLICATION DIAGRAMS

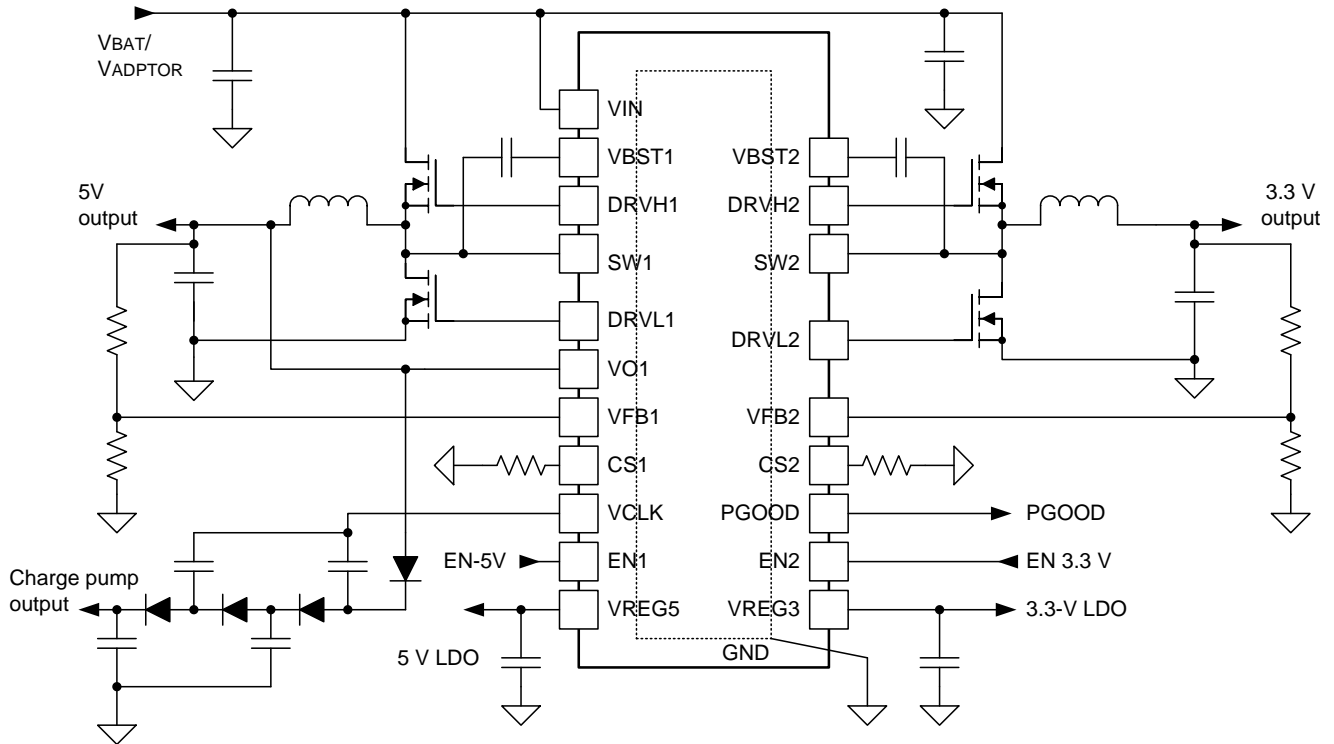

Figure 1. TYPICAL APPLICATION DIAGRAM (With Charge Pump)

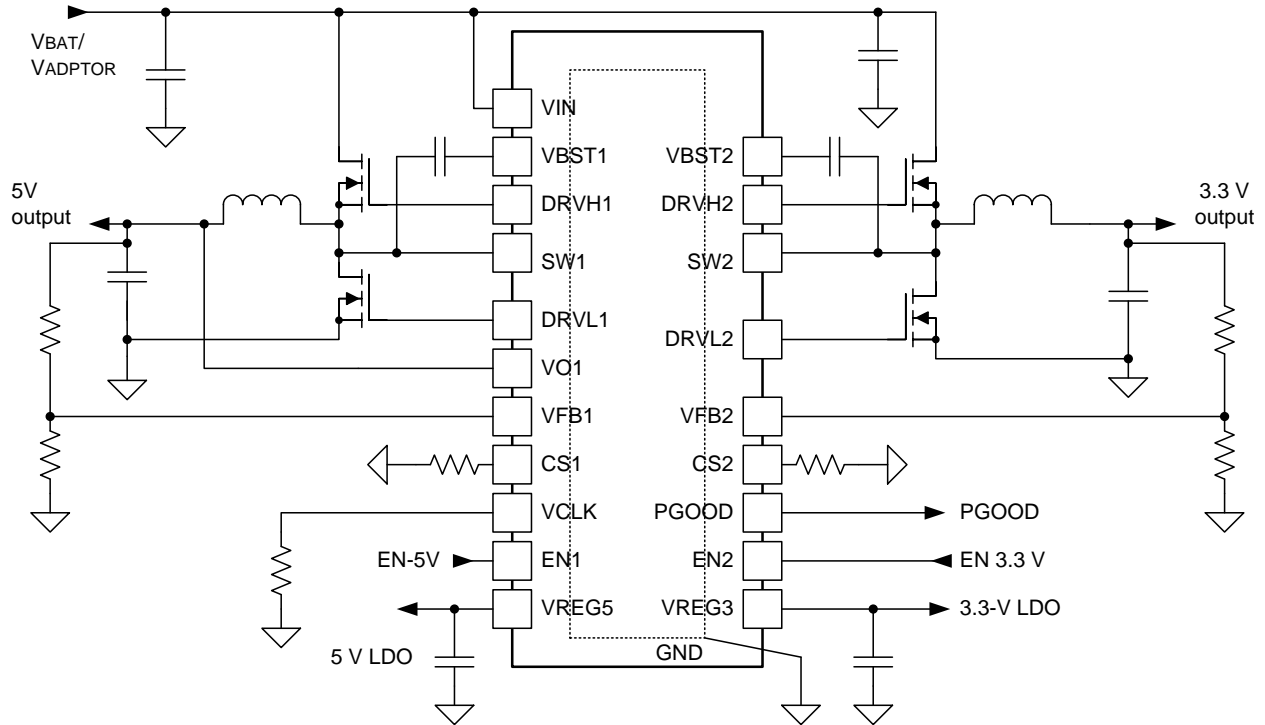

Figure 2. TYPICAL APPLICATION DIAGRAM (Without Charge Pump)

## ABSOLUTE MAXIMUM RATINGS<sup>(1)</sup>

over operating free-air temperature range (unless otherwise noted)

		VALUE		UNIT
		MIN	MAX	
Input voltage <sup>(2)</sup>	VBST1, VBST2	-0.3	32	V
	VBST1, VBST2 <sup>(3)</sup>	-0.3	6	
	SW1, SW2	-6	26	
	VIN	-0.3	26	
	EN1, EN2	-0.3	6	
	VFB1, VFB2	-0.3	3.6	
	VO1	-0.3	6	
Output voltage <sup>(2)</sup>	DRVH1, DRVH2	-6.0	32	V
	DRVH1, DRVH2 <sup>(3)</sup>	-0.3	6	
	DRVH1, DRVH2 <sup>(3)</sup> (duty cycle < 1%)	-2.5	6	
	DRVL1, DRVL2	-0.3	6	
	DRVL1, DRVL2 (duty cycle < 1%)	-2.5	6	
	PGOOD, VCLK, VREG5	-0.3	6	
	VREG3, CS1, CS2	-0.3	3.6	
Electrostatic discharge (ESD) ratings <sup>(4)</sup>	Human Body Model (HBM)		2	kV
	Charged Device Model (CDM)		0.5	
Junction temperature, T <sub>J</sub>			150	°C
Storage temperature, T <sub>ST</sub>		-55	150	°C

- (1) Stresses beyond those listed under "absolute maximum ratings" may cause permanent damage to the device. These are stress ratings only and functional operation of the device at these or any other conditions beyond those indicated under "recommended operating conditions" is not implied. Exposure to absolute-maximum-rated conditions for extended periods may affect device reliability.
- (2) All voltage values are with respect to the network ground terminal unless otherwise noted
- (3) Voltage values are with respect to SW terminals.
- (4) ESD testing is performed according to the respective JESD22 JEDEC standard.

## THERMAL INFORMATION

THERMAL METRIC <sup>(1)</sup>		TPS51285A TPS51285B	UNITS
		20-PIN RUK	
$\theta_{JA}$	Junction-to-ambient thermal resistance	46.2	°C/W
$\theta_{Jc\text{top}}$	Junction-to-case (top) thermal resistance	53.6	
$\theta_{JB}$	Junction-to-board thermal resistance	19.2	
$\psi_{JT}$	Junction-to-top characterization parameter	0.6	
$\psi_{JB}$	Junction-to-board characterization parameter	19.2	
$\theta_{Jc\text{bot}}$	Junction-to-case (bottom) thermal resistance	3.6	

- (1) For more information about traditional and new thermal metrics, see the IC Package Thermal Metrics application report, [SPRA953](#).

## RECOMMENDED OPERATING CONDITIONS

over operating free-air temperature range (unless otherwise noted)

		MIN	TYP	MAX	UNIT
Supply voltage	VIN	5		24	
Input voltage <sup>(1)</sup>	VBST1, VBST2	-0.1		30	V
	VBST1, VBST2 <sup>(2)</sup>	-0.1		5.5	
	SW1, SW2	-5.5		24	
	EN1, EN2	-0.1		5.5	
	VFB1, VFB2	-0.1		3.5	
	VO1	-0.1		5.5	
Output voltage <sup>(1)</sup>	DRVH1, DRVH2	-5.5		30	V
	DRVH1, DRVH2 <sup>(2)</sup>	-0.1		5.5	
	DRVL1, DRVL2	-0.1		5.5	
	PGOOD, VCLK, VREG5	-0.1		5.5	
	VREG3, CS1, CS2	-0.1		3.5	
Operating free-air temperature, T <sub>A</sub>		-40		85	°C

(1) All voltage values are with respect to the network ground terminal unless otherwise noted.

(2) Voltage values are with respect to the SW terminal.

## ELECTRICAL CHARACTERISTICS

over operating free-air temperature range,  $V_{VIN} = 12\text{ V}$ ,  $V_{VO1} = 5\text{ V}$ ,  $V_{VFB1} = V_{VFB2} = 2\text{ V}$ ,  $V_{EN1} = V_{EN2} = 3.3\text{ V}$ ,  $V_{CLK}: 200\ \Omega$  to GND

(unless otherwise noted)

PARAMETER		TEST CONDITION	MIN	TYP	MAX	UNIT
<b>SUPPLY CURRENT</b>						
$I_{VIN1}$	VIN supply current-1	$T_A = 25^\circ\text{C}$ , No load, $V_{VO1} = 0\text{ V}$ , $V_{VFB1} = V_{VFB2} = 2.06\text{ V}$		84		$\mu\text{A}$
$I_{VIN2}$	VIN supply current-2	$T_A = 25^\circ\text{C}$ , No load, $V_{VFB1} = V_{VFB2} = 2.06\text{ V}$		10		$\mu\text{A}$
$I_{VO1}$	VO1 supply current	$T_A = 25^\circ\text{C}$ , No load, $V_{VFB1} = V_{VFB2} = 2.06\text{ V}$		70		$\mu\text{A}$
$I_{VIN(STBY)}$	VIN stand-by current	TPS51285A		25		$\mu\text{A}$
		TPS51285B	$T_A = 25^\circ\text{C}$ , No load, $V_{VO1} = 0\text{ V}$ , $V_{EN1} = V_{EN2} = 0\text{ V}$		28	
<b>INTERNAL REFERENCE</b>						
$V_{FBx}$	VFB regulation voltage	$T_A = 25^\circ\text{C}$	1.99	2	2.01	V
			1.98	2	2.02	V
$I_{FBx}$	VFB Leakage Current	$T_A = 25^\circ\text{C}$			0.1	$\mu\text{A}$
<b>VREG5 OUTPUT</b>						
$V_{VREG5}$	VREG5 output voltage	$T_A = 25^\circ\text{C}$ , No load, $V_{VO1} = 0\text{ V}$	4.9	5	5.1	V
		$V_{VIN} > 7\text{ V}$ , $V_{VO1} = 0\text{ V}$ , $I_{VREG5} < 100\text{ mA}$	4.85	5	5.1	
		$V_{VIN} > 5.5\text{ V}$ , $V_{VO1} = 0\text{ V}$ , $I_{VREG5} < 35\text{ mA}$	4.85	5	5.1	
		$V_{VIN} > 5\text{ V}$ , $V_{VO1} = 0\text{ V}$ , $I_{VREG5} < 20\text{ mA}$	4.55	4.75	5.1	
$I_{VREG5}$	VREG5 current limit	$V_{VO1} = 0\text{ V}$ , $V_{VREG5} = 4.5\text{ V}$ , $V_{VIN} = 7\text{ V}$	100	140		mA
$R_{V5SW}$	5-V switch resistance	$T_A = 25^\circ\text{C}$ , $V_{VO1} = 5\text{ V}$ , $I_{VREG5} = 50\text{ mA}$		1.8		$\Omega$
<b>VREG3 OUTPUT</b>						
$V_{VREG3}$	VREG3 output voltage	$V_{VIN} > 7\text{ V}$ , $V_{VO1} = 0\text{ V}$ , $I_{VREG3} < 100\text{ mA}$	3.217	3.3	3.383	V
		$V_{VIN} > 5.5\text{ V}$ , $V_{VO1} = 0\text{ V}$ , $I_{VREG3} < 35\text{ mA}$	3.234	3.3	3.366	
		$0^\circ\text{C} \leq T_A \leq 85^\circ\text{C}$ , $V_{VIN} > 5.5\text{ V}$ , $V_{VO1} = 0\text{ V}$ , $I_{VREG3} < 35\text{ mA}$	3.267	3.3	3.333	
		$0^\circ\text{C} \leq T_A \leq 85^\circ\text{C}$ , $V_{VIN} > 5.5\text{ V}$ , $I_{VREG3} < 35\text{ mA}$	3.267	3.3	3.333	
		$V_{VIN} > 5\text{ V}$ , $V_{VO1} = 0\text{ V}$ , $I_{VREG3} < 35\text{ mA}$	3.217	3.3	3.366	
$I_{VREG3-1}$	VREG3 current limit-1	$V_{VO1} = 0\text{ V}$ , $V_{VREG3} = 3.15\text{ V}$ , $V_{VIN} = 7\text{ V}$	100	200		mA
$I_{VREG3-2}$	VREG3 current limit-2	$V_{VREG3} = 3.15\text{ V}$ , $V_{VIN} = 7\text{ V}$	100	200		
<b>DUTY CYCLE and FREQUENCY CONTROL</b>						
$f_{sw1}$	CH1 frequency <sup>(1)</sup>	$T_A = 25^\circ\text{C}$ , $V_{VIN} = 20\text{ V}$		400		kHz
$f_{sw2}$	CH2 frequency <sup>(1)</sup>	$T_A = 25^\circ\text{C}$ , $V_{VIN} = 20\text{ V}$		475		kHz
$t_{OFF(MIN)}$	Minimum off-time	$T_A = 25^\circ\text{C}$	200	300	400	ns
<b>MOSFET DRIVERS</b>						
$R_{DRVH}$	DRVH resistance	Source, $I_{DRVH} = -50\text{ mA}$ , $(V_{VBST} - V_{SW}) = 5\text{ V}$		3		$\Omega$
		Sink, $I_{DRVH} = 50\text{ mA}$ , $(V_{VBST} - V_{SW}) = 5\text{ V}$		1.9		
$R_{DRVL}$	DRVL resistance	Source, $I_{DRVL} = -50\text{ mA}$ , $V_{VREG5} = 5\text{ V}$		3		$\Omega$
		Sink, $I_{DRVL} = 50\text{ mA}$ , $V_{VREG5} = 5\text{ V}$		0.9		
$t_D$	Dead time	DRVH-off to DRVL-on		12		ns
		DRVL-off to DRVH-on		20		
<b>INTERNAL BOOT STRAP SWITCH</b>						
$R_{VBST(ON)}$	Boost switch on-resistance	$T_A = 25^\circ\text{C}$ , $I_{VBST} = 10\text{ mA}$		13		$\Omega$
$I_{VBSTLK}$	VBST leakage current	$T_A = 25^\circ\text{C}$			1	$\mu\text{A}$
<b>CLOCK OUTPUT</b>						
$R_{VCLK}$	VCLK on-resistance (pull-up)	$T_A = 25^\circ\text{C}$ , VCLK: Open		10		$\Omega$
	VCLK on-resistance (pull-down)	$T_A = 25^\circ\text{C}$ , VCLK: Open		10		
$f_{CLK}$	Clock frequency	$T_A = 25^\circ\text{C}$ , VCLK: Open		256		kHz

(1) Specified by design. Not production tested.

**ELECTRICAL CHARACTERISTICS (continued)**

over operating free-air temperature range,  $V_{VIN} = 12\text{ V}$ ,  $V_{VO1} = 5\text{ V}$ ,  $V_{VFB1} = V_{VFB2} = 2\text{ V}$ ,  $V_{EN1} = V_{EN2} = 3.3\text{ V}$ ,  $V_{CLK}: 200\ \Omega$  to GND

(unless otherwise noted)

PARAMETER		TEST CONDITION	MIN	TYP	MAX	UNIT
<b>OUTPUT DISCHARGE</b>						
$R_{DIS1}$	CH1 discharge resistance	$T_A = 25^\circ\text{C}$ , $V_{VO1} = 0.5\text{ V}$ $V_{EN1} = V_{EN2} = 0\text{ V}$		35		$\Omega$
$R_{DIS2}$	CH2 discharge resistance	TPS51285A		75		$\Omega$
		TPS51285B	$T_A = 25^\circ\text{C}$ , $V_{SW2} = 0.5\text{ V}$ , $V_{EN1} = V_{EN2} = 0\text{ V}$	70		
<b>SOFT START</b>						
$t_{SS}$	Soft-start time (From ENx Hi)	From ENx="Hi" and $V_{VREG5} > V_{UVLO5}$ to $V_{OUT} = 95\%$		0.91		ms
$t_{SSRAMP}$	Soft-start time (ramp-up)	$V_{OUT} = 0\%$ to $V_{OUT} = 95\%$ , $V_{VREG5} = 5\text{ V}$		0.78		ms
<b>POWER GOOD</b>						
$t_{PGDEL}$	PG start-up delay	From EN1 = "Hi", EN2 = "Hi", and $V_{VREG5} > V_{UVLO5}$		1.65		ms
$V_{PGTH}$	PG threshold	PGOOD in from lower (start-up)	87.5%	90%	92.5%	
$I_{PGMAX}$	PG sink current	$V_{PGOOD} = 0.5\text{ V}$		6.5		mA
$I_{PGLK}$	PG leak current	$V_{PGOOD} = 5.5\text{ V}$			1	$\mu\text{A}$
<b>CURRENT SENSING</b>						
$I_{CS}$	CS source current	$T_A = 25^\circ\text{C}$ , $V_{CS} = 0.4\text{ V}$	45	50	55	$\mu\text{A}$
$TC_{CS}$	CS current temperature coefficient <sup>(2)</sup>	On the basis of $25^\circ\text{C}$		4500		ppm/ $^\circ\text{C}$
$V_{CS}$	CS Current limit setting range		0.2		2	V
$V_{AZCADJ}$	Adaptive zero cross adjustable range	Positive	5	10		mV
		Negative		-10	-5	
<b>LOGIC THRESHOLD</b>						
$V_{ENX(ON)}$	EN threshold high-level	SMPS on level			1.6	V
$V_{ENX(OFF)}$	EN threshold low-level	SMPS off level	0.3			V
$I_{EN}$	EN input current	$V_{ENx} = 3.3\text{ V}$			1	$\mu\text{A}$
<b>OUTPUT OVERVOLTAGE PROTECTION</b>						
$V_{OVP}$	OVP trip threshold		112.5%	115%	117.5%	
$t_{OVPDLY}$	OVP propagation delay	$T_A = 25^\circ\text{C}$		0.5		$\mu\text{s}$
<b>OUTPUT UNDERVOLTAGE PROTECTION</b>						
$V_{UVP}$	UVP trip Threshold		55%	60%	65%	
$V_{UVP-ST}$	UVP trip Threshold	Start Up	87.5%	90%	92.5%	
$t_{UVPDLY}$	UVP prop delay			250		$\mu\text{s}$
$t_{UVPENDLY}$	UVP enable delay	From ENx = "Hi", $V_{VREG5} = 5\text{ V}$		1.1		ms
<b>UVLO</b>						
$V_{UVLOVIN}$	VIN UVLO Threshold	Wake up	4.2	4.58	4.95	V
		Shutdown	3.75	4.1	4.45	V
$V_{UVLO5}$	VREG5 UVLO Threshold	Wake up	4.08	4.38	4.55	V
		Shutdown	3.7	4	4.3	V
$V_{UVLO3}$	VREG3 UVLO Threshold	Wake up	3	3.15	3.26	V
		Shutdown	2.75	3	3.21	V

(2) Specified by design. Not production tested.

## DEVICE INFORMATION

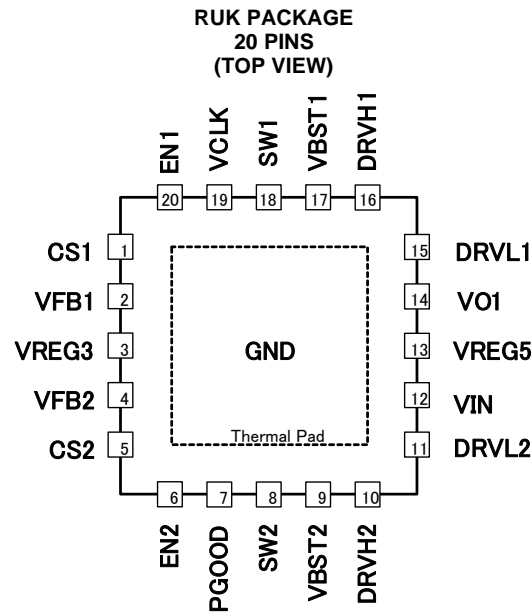

### PIN FUNCTIONS

NAME	PIN NO.	I/O	DESCRIPTION
CS1	1	O	Sets the channel 1 OCL trip level.
CS2	5	O	Sets the channel 2OCL trip level.
DRVH1	16	O	High-side driver output
DRVH2	10	O	High-side driver output
DRVL1	15	O	Low-side driver output
DRVL2	11	O	Low-side driver output
EN1	20	I	Channel 1 enable.
EN2	6	I	Channel 2 enable.
PGOOD	7	O	Power good output flag. Open drain output. Pull up to external rail via a resistor
SW1	18	O	Switch-node connection.
SW2	8	O	Switch-node connection.
VBST1	17	I	Supply input for high-side MOSFET (bootstrap terminal). Connect capacitor from this pin to SW terminal.
VBST2	9	I	
VCLK	19	O	Clock output for charge pump.
VFB1	2	I	Voltage feedback Input
VFB2	4	I	
VIN	12	I	Power conversion voltage input. Apply the same voltage as drain voltage of high-side MOSFETs of channel 1 and channel 2.
VO1	14	I	Output voltage input, 5-V input for switch-over.
VREG3	3	O	3.3-V LDO output.
VREG5	13	O	5-V LDO output.
Thermal pad (GND)			GND terminal, solder to the ground plane

FUNCTIONAL BLOCK DIAGRAM

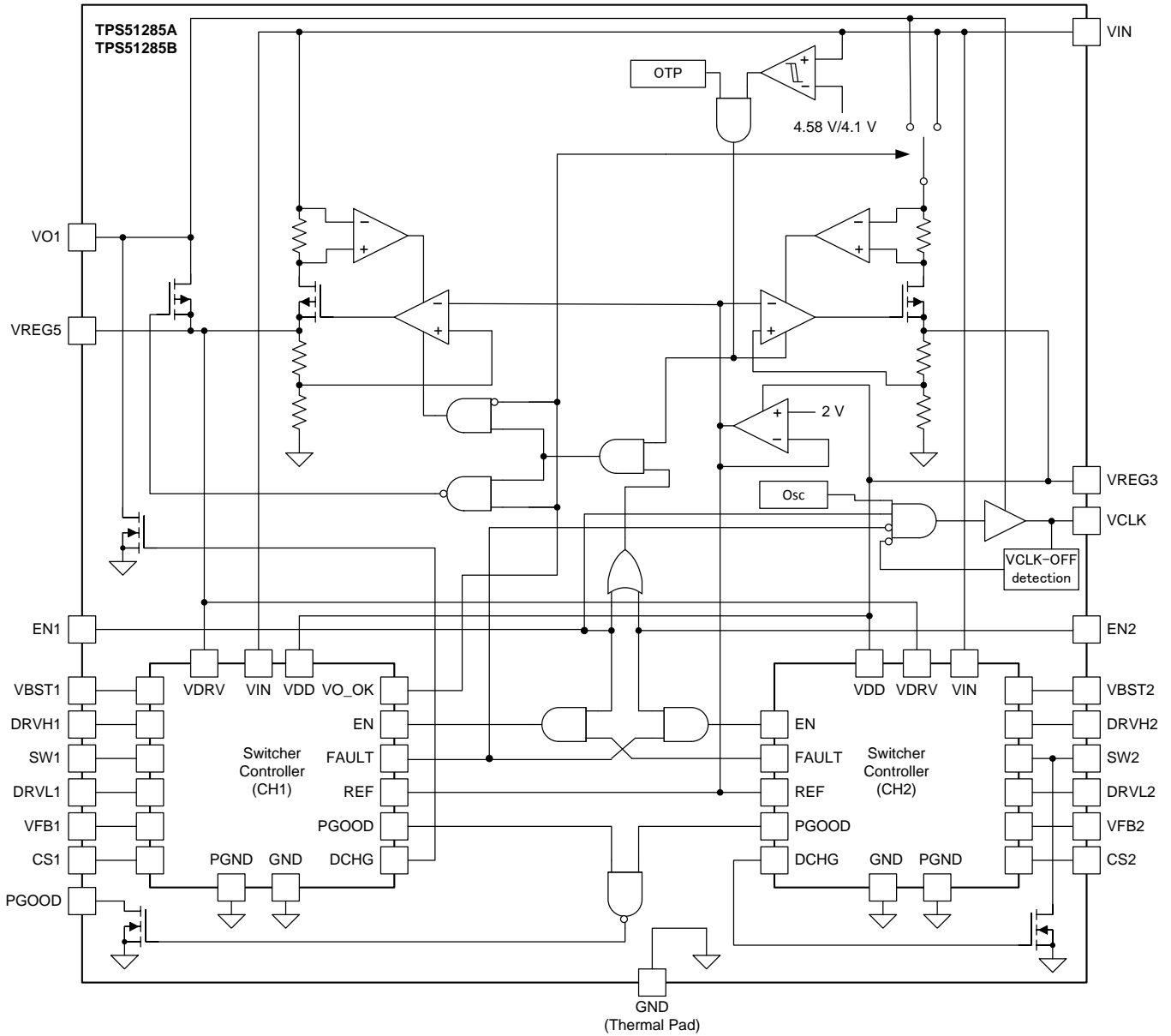

**SWITCHER CONTROLLER BLOCK DIAGRAM**

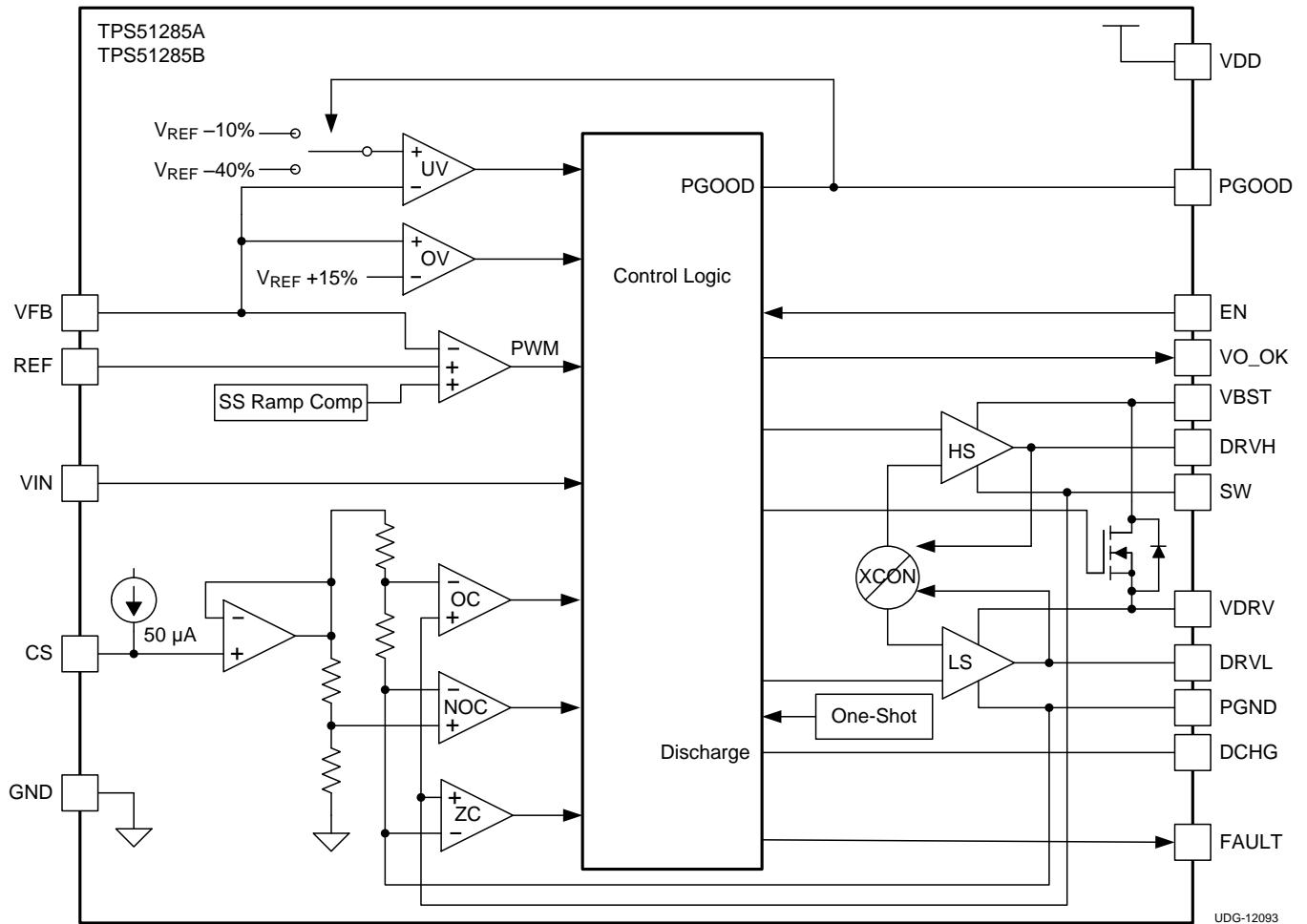

## DETAILED DESCRIPTION

### PWM Operations

The main control loop of the switch mode power supply (SMPS) is designed as an adaptive on-time pulse width modulation (PWM) controller. It supports a proprietary D-CAP™ mode. D-CAP™ mode does not require external compensation circuits and is suitable for low external component count configuration when used with appropriate amount of ESR at the output capacitor(s).

At the beginning of each cycle, the synchronous high-side MOSFET is turned on, or enters the ON state. This MOSFET is turned off, or enters the 'OFF state, after the internal, one-shot timer expires. The MOSFET is turned on again when the feedback point voltage,  $V_{VFB}$ , decreased to match the internal 2-V reference. The inductor current information is also monitored and should be below the overcurrent threshold to initiate this new cycle. By repeating the operation in this manner, the controller regulates the output voltage. The synchronous low-side (rectifying) MOSFET is turned on at the beginning of each OFF state to maintain a minimum of conduction loss. The low-side MOSFET is turned off before the high-side MOSFET turns on at next switching cycle or when the detecting inductor current decreases to zero. This enables seamless transition to the reduced frequency operation during light-load conditions so that high efficiency is maintained over a broad range of load current.

### Adaptive On-Time/ PWM Frequency Control

Because the device does not have a dedicated oscillator for control loop on board, switching cycle is controlled by the adaptive on-time circuit. The on-time is controlled to meet the target switching frequency by forwarding the input and output voltage into the on-time one-shot timer. To achieve higher duty operation for lower input voltage application (2-cell battery), the target switching frequency is varied according to the input voltage. The switching frequency of CH1 (5-V output) is 400kHz during continuous conduction mode (CCM) operation when  $V_{IN} = 20$  V. The CH2 (3.3-V output) is 475 kHz during CCM when  $V_{IN} = 20$  V.

To improve load transient performance and load regulation in lower input voltage condition, device can extend the on-time. The maximum on-time extension of CH1 is 5 times. For CH2, it is 2 times. To maintain a reasonable inductor ripple current during on-time extension, the inductor ripple current should be set to less than half of the OCL (valley) threshold. The on-time extension function provides high duty cycle operation and shows better DC (static) performance. AC performance is determined mostly by the output LC filter and resistive factor in the loop.

### Light Load Condition in Auto-Skip Operation

The device automatically reduces switching frequency during light-load conditions to maintain high efficiency. This reduction of frequency is achieved smoothly. A more detailed description of this operation is as follows. As the output current decreases from heavy-load condition, the inductor current is also reduced and eventually approaches valley zero current, which is the boundary between continuous conduction mode and discontinuous conduction mode. The rectifying MOSFET is turned off when this zero inductor current is detected. As the load current further decreases, the converter runs in discontinuous conduction mode and it takes longer and longer to discharge the output capacitor to the level that requires the next ON cycle. In reverse, when the output current increase from light load to heavy load, the switching frequency increases to the preset value as the inductor current reaches to the continuous conduction. The transition load point to the light load operation  $I_{OUT(LL)}$  (that is, the threshold between continuous and discontinuous conduction mode) can be calculated as shown in [Equation 1](#).

$$I_{OUT(LL)} = \frac{1}{2 \times L \times f_{SW}} \times \frac{(V_{IN} - V_{OUT}) \times V_{OUT}}{V_{IN}}$$

where

- $f_{SW}$  is the PWM switching frequency (1)

Switching frequency versus output current during light-load conditions is a function of inductance (L), input voltage ( $V_{IN}$ ) and output voltage ( $V_{OUT}$ ), but it decreases almost proportional to the output current from the  $I_{OUT(LL)}$ .

## ULQ™ Mode

To achieve longer battery life in system stand-by mode of mobile devices, the device implements Ultra Low Quiescent (ULQ) mode. In the ULQ mode, the device consumes low quiescent current (see the [ELECTRICAL CHARACTERISTICS](#) table). Therefore, high efficiency can be obtained in the system stand-by mode. The TPS51285A/B enters the ULQ mode automatically (no control input signal is required) when both high-side and low-side MOSFET drivers are OFF state in discontinuous conduction operation. It exits from the ULQ mode when the PWM comparator detects VFB drops to the internal 2-V VREF and turns on the high-side MOSFET. In the ULQ mode, all protection functions are active.

## D-CAP™ Mode

From small-signal loop analysis, a buck converter using D-CAP™ mode can be simplified as shown in [Figure 3](#).

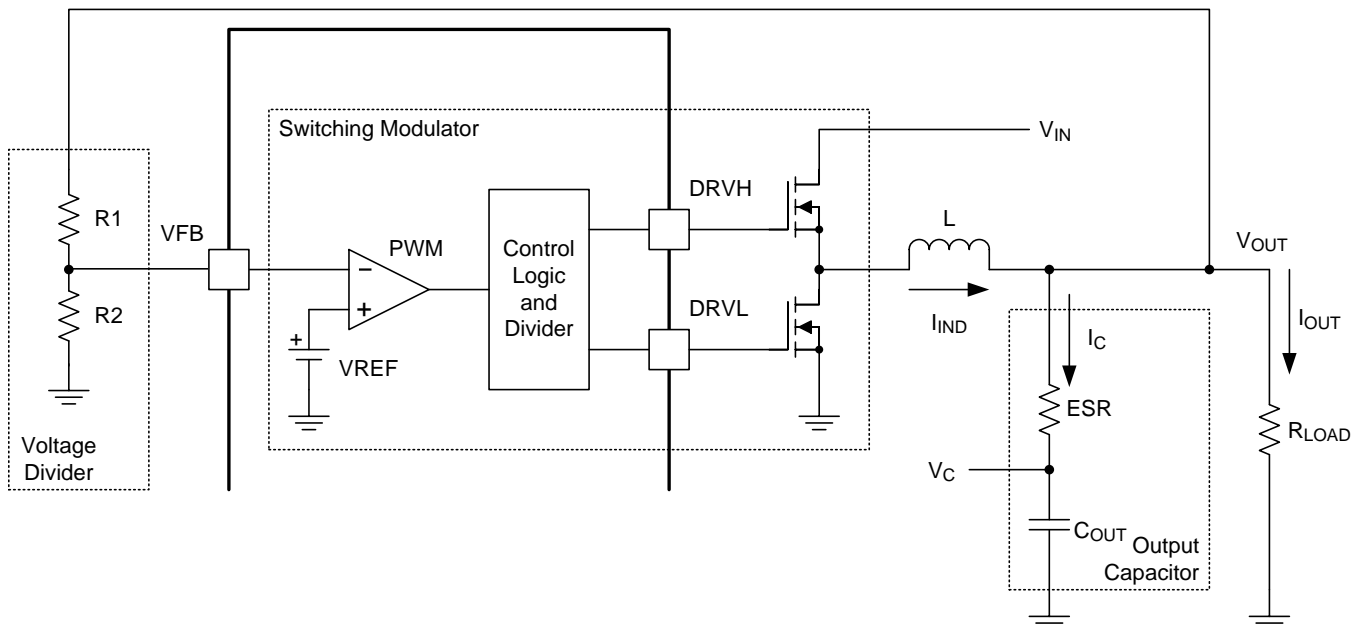

**Figure 3. Simplifying the Modulator**

The output voltage is compared with internal reference voltage after divider resistors, R1 and R2. The PWM comparator determines the timing to turn on the high-side MOSFET. The gain and speed of the comparator is high enough to keep the voltage at the beginning of each ON cycle substantially constant. For the loop stability, the 0 dB frequency,  $f_0$ , defined in [Equation 2](#) must be lower than 1/4 of the switching frequency.

$$f_0 = \frac{1}{2\pi \times \text{ESR} \times C_{\text{OUT}}} \leq \frac{f_{\text{SW}}}{4} \quad (2)$$

As  $f_0$  is determined solely by the output capacitor characteristics, the loop stability during D-CAP™ mode is determined by the capacitor chemistry. For example, specialty polymer capacitors have output capacitance in the order of several hundred micro-Farads and ESR in range of 10 milli-ohms. These yield an  $f_0$  value on the order of 100 kHz or less and the loop is stable. However, ceramic capacitors have  $f_0$  at more than 700 kHz, which is not suitable for this operational mode.

## Enable and Power Good

VREG3 is an always-on regulator (TPS51285A and TPS1285B), For TPS51285B, VREG5 is an always-on LDO, too (See [Table 1](#) and [Table 2](#)). When VIN exceeds the VIN-UVLO threshold VREG3 turns on. For TPS51285B, VREG5 turns on when VREG3 exceeds 2.4V. For TPS51285A, VREG5 turns on when either EN1 or EN2 enters ON state in addition to the above VREG3 threshold. CH1's or CH2's output starts ramping up when the corresponding EN pin is in the ON state and VREG5 is larger than the VREG5-UVLO. VCLK initiates switching when EN1 enters ON state. The state controls are shown in [Table 1](#) and [Table 2](#).

TPS51285A and TPS51285B have a PGOOD open drain output. During the start-up, if the feedback voltages for both CH1 and CH2 exceed 90% of the reference voltage, the PGOOD becomes high with defined PGOOD delay time. During the operation, if the feedback voltage rise beyond 115%(typ) for either switching regulator, PGOOD turns low. If the feedback voltage falls below 60%(typ), the PGOOD turns low.

**Table 1. Enabling and PGOOD State (TPS51285A; Always-on VREG3)**

EN1	EN2	VREG5	VREG3	CH1 (5Vout)	CH2 (3.3Vout)	VCLK	PGOOD
OFF	OFF	OFF	ON	OFF	OFF	OFF	Low
ON	OFF	ON	ON	ON	OFF	ON	Low
OFF	ON	ON	ON	OFF	ON	OFF	Low
ON	ON	ON	ON	ON	ON	ON	High

**Table 2. Enabling and PGOOD State (TPS51285B; Always-on VREG3 and VREG5)**

EN1	EN2	VREG5	VREG3	CH1 (5Vout)	CH2 (3.3Vout)	VCLK	PGOOD
OFF	OFF	ON	ON	OFF	OFF	OFF	Low
ON	OFF	ON	ON	ON	OFF	ON	Low
OFF	ON	ON	ON	OFF	ON	OFF	Low
ON	ON	ON	ON	ON	ON	ON	High

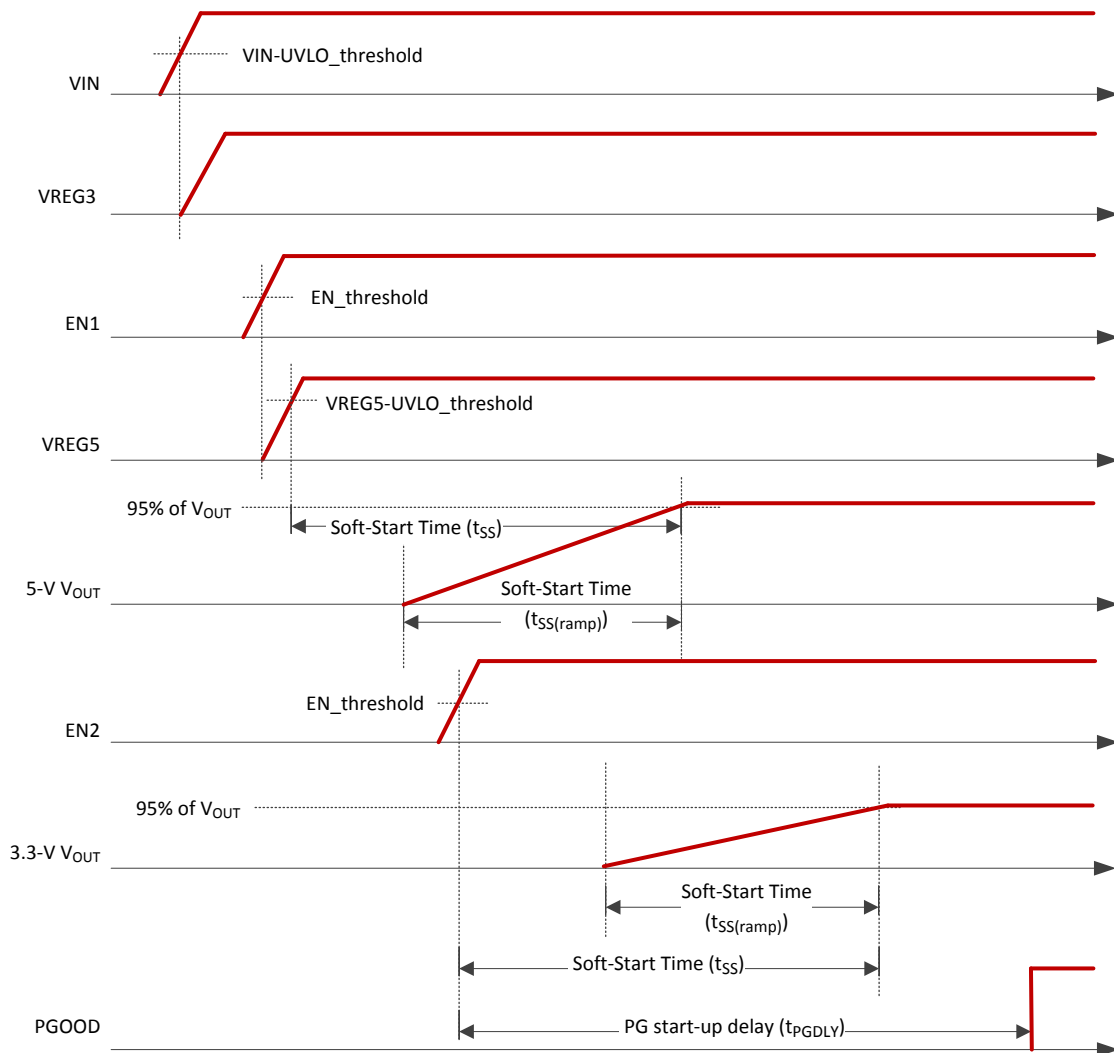

**Figure 4. TPS51285A Timing Diagram of Start-up**

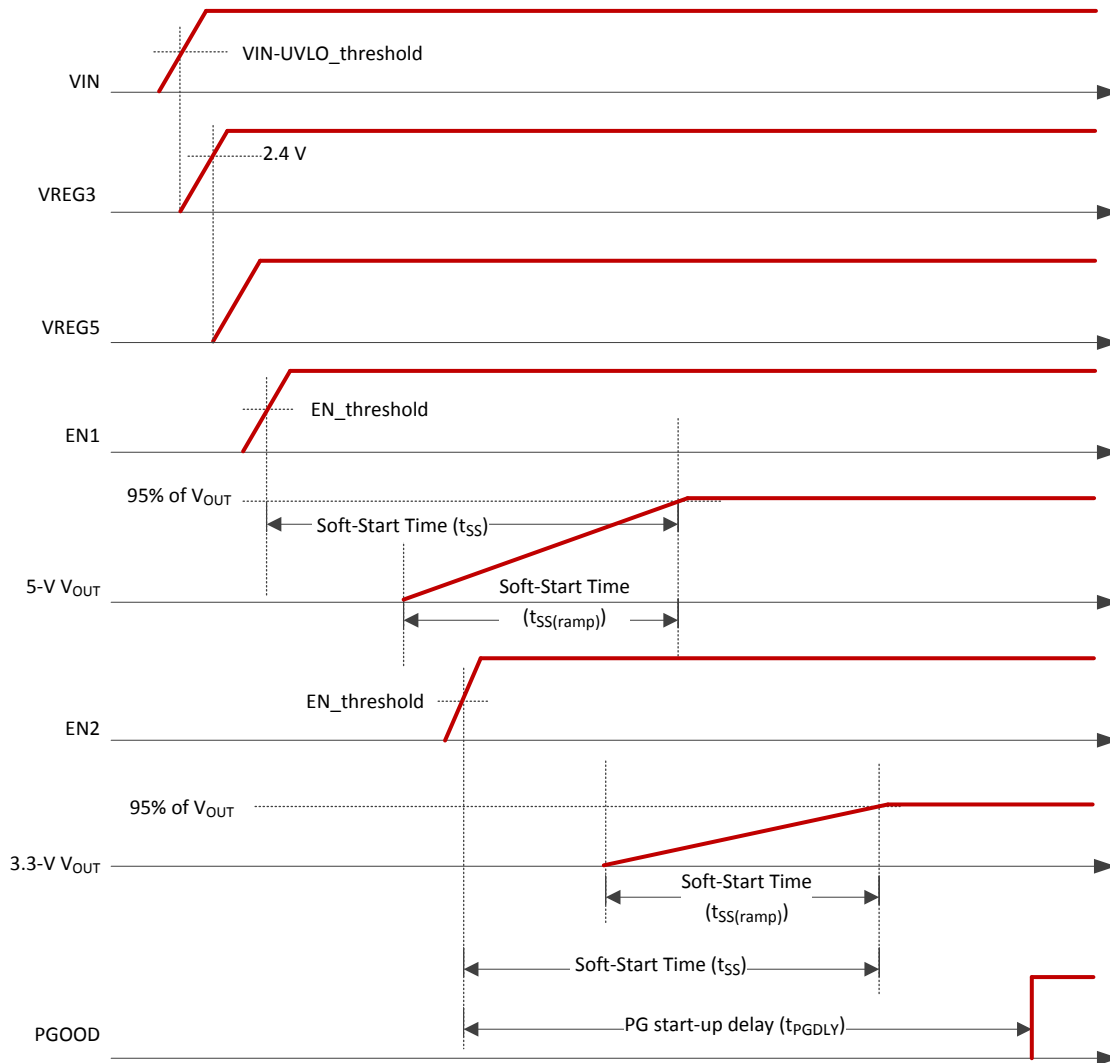

Figure 5. TPS51285B Timing Diagram of Start-up

## Soft-Start and Discharge

The TPS51285A and TPS51285B operates an internal, 0.8-ms, voltage servo soft-start for each channel. When the ENx pin becomes higher than the enable threshold voltage, an internal DAC begins ramping up the reference voltage to the target (2 V). Smooth control of the output voltage is maintained during start-up. When ENx becomes lower than the lower level of threshold voltage, the device discharges outputs using internal MOSFETs through VO1 (CH1) and SW2 (CH2).

## VREG5 and VREG3 Linear Regulators

There are two 100-mA standby linear regulators that output 5 V and 3.3 V, respectively. The VREG5 provides the current for gate drivers. VREG3 functions as the main power supply for the analog circuitry of the device.

A ceramic capacitor with a value of 4.7  $\mu\text{F}$  or larger (X5R grade or better) is required for each of VREG5 and VREG3. It should be placed close to the VREG5 pin and the VREG3 pin respectively to stabilize the LDOs.

The VREG5 pin switchover function is asserted when three conditions are present:

- CH1 is not in UVP/OVP condition
- CH1 is not in OCL condition
- VO1 voltage is higher than (VREG5 -1V)

In this switchover condition three things occur:

- the internal 5-V LDO regulator is shut off
- the VREG5 output is connected to VO1 by internal switchover MOSFET
- VREG3 input pass is changed from VIN to VO1

## VCLK for Charge Pump

A 256 kHz VCLK signal can be used for the external charge pump circuit. The VCLK signal becomes available when EN1 enters ON state. VCLK driver circuit is driven by VO1 voltage. In a design that does not require VCLK output, tie 200  $\Omega$  between VCLK pin and GND so that VCLK is turned off.

## Overcurrent Protection

TPS51285A and TPS51285B have cycle-by-cycle over current limiting control. The inductor current is monitored during the OFF state and the controller maintains the OFF state during the inductor current is larger than the overcurrent trip level. In order to provide both good accuracy and cost effective solution, the device supports temperature compensated MOSFET  $R_{\text{DS(on)}}$  sensing. The CSx pin should be connected to GND through the CS voltage setting resistor,  $R_{\text{CS}}$ . The CSx pin sources CS current ( $I_{\text{CS}}$ ) which is 50  $\mu\text{A}$  typically at room temperature, and the CSx terminal voltage ( $V_{\text{CS}} = R_{\text{CS}} \times I_{\text{CS}}$ ) should be in the range of 0.2 V to 2 V over all operation temperatures. The trip level is set to the OCL trip voltage ( $V_{\text{TRIP}}$ ) as shown in [Equation 3](#).

$$V_{\text{TRIP}} = \frac{R_{\text{CS}} \times I_{\text{CS}}}{8} + 1 \text{ mV} \quad (3)$$

The inductor current is monitored by the voltage between GND pin and SWx pin so that SWx pin should be connected to the drain terminal of the low-side MOSFET properly. The CS pin current has a 4500 ppm/ $^{\circ}\text{C}$  temperature slope to compensate the temperature dependency of the  $R_{\text{DS(on)}}$ . GND is used as the positive current sensing node so that GND should be connected to the source terminal of the low-side MOSFET.

As the comparison is done during the OFF state,  $V_{\text{TRIP}}$  sets the valley level of the inductor current. Thus, the load current at the overcurrent threshold,  $I_{\text{OCL(DC)}}$ , can be calculated as shown in [Equation 4](#).

$$I_{\text{OCL(DC)}} = \frac{V_{\text{TRIP}}}{R_{\text{DS(on)}}} + \frac{I_{\text{IND(ripple)}}}{2} = \frac{V_{\text{TRIP}}}{R_{\text{DS(on)}}} + \frac{1}{2 \times L \times f_{\text{SW}}} \times \frac{(V_{\text{IN}} - V_{\text{OUT}}) \times V_{\text{OUT}}}{V_{\text{IN}}} \quad (4)$$

In an overcurrent condition, the current to the load exceeds the current to the output capacitor thus the output voltage tends to fall down. Eventually, it ends up with crossing the undervoltage protection threshold and shutdown both channels.

## Output Overvoltage and Undervoltage Protection

TPS51285A and TPS51285B assert the overvoltage protection (OVP) when VFBx voltage reaches OVP trip threshold level. When an OVP event is detected, the controller changes the output target voltage to 0 V. This usually turns off DRVH and forces DRVL to be on. When the inductor current begins to flow through the low-side MOSFET and reaches the negative OCL, DRVL is turned off and DRVH is turned on. After the on-time expires, DRVH is turned off and DRVL is turned on again. This action minimizes the output node undershoot due to LC resonance. When the VFBx reaches 0 V, the driver output is latched as DRVH off and DRVL on. The undervoltage protection (UVP) latch is set when the VFBx voltage remains lower than UVP trip threshold voltage for 250  $\mu$ s or longer. In this fault condition, the controller latches DRVH low and DRVL low and discharges the outputs through VO1(CH1) and SW2 (CH2). UVP detection function is enabled after 1.1 ms of SMPS operation to ensure startup. Toggle ENx to clear the fault latch.

## Undervoltage Lockout (UVLO) Protection

TPS51285A and B have undervoltage lock out protection at VIN, VREG5 and VREG3. When each voltage is lower than their UVLO threshold voltage, both SMPS are shut-off. They are non-latch protections.

## Over-Temperature Protection

TPS51285A and TPS51285B features an internal temperature monitor. If the temperature exceeds the threshold value (typically 140°C), the device is shut off including LDOs. This is non-latch protection.

## REFERENCE DESIGN

### Application Schematic

This session describes a simplified design procedure for 5 V and 3.3 V outputs application using TPS1285A and TPS1285B. Figure 6 shows the application schematic.

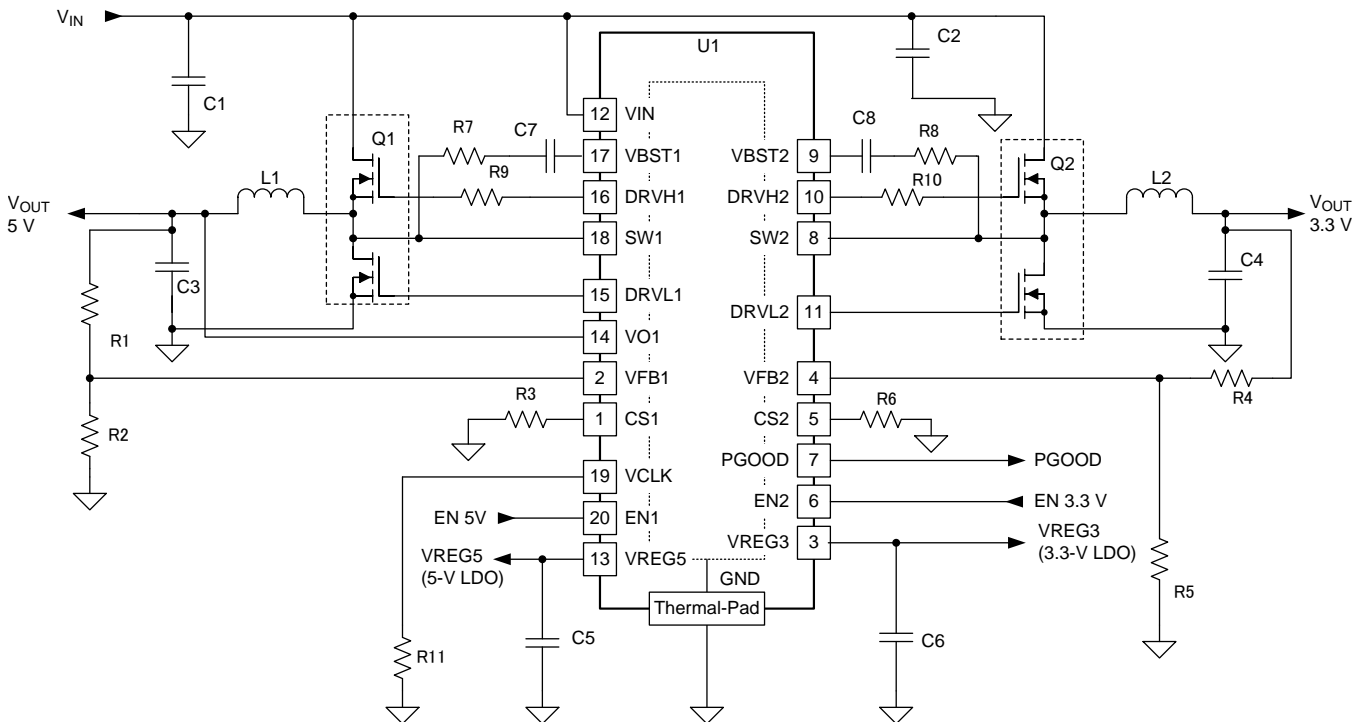

Figure 6. Application Schematic

**Table 3. Key External Components**

REFERENCE DESIGNATOR	FUNCTION	MANUFACTURER	PART NUMBER
L1	Output Inductor (5-Vout)	ALPS	GLMC3R303A
L2	Output Inductor (3.3-Vout)	ALPS	GLMC2R203A
C3	Output Capacitor (5-Vout)	SANYO	6TPS220MAZB x 2
C4	Output Capacitor (3.3-Vout)	SANYO	6TPS220MAZB x 2
Q1	MOSFET (5-Vout)	TI	CSD87330Q3D
Q2	MOSFET (3.3-Vout)	TI	CSD87330Q3D
C5	Decoupling Capacitance (VREG5)	MURATA	GRM188B30J475ME84
C6	Decoupling Capacitance (VREG3)	MURATA	GRM188B30J475ME84

## Design Procedure

### Step 1. Determine the Specifications:

- VIN range = 5.5 V to 20 V
- CH1 output: Vout1 = 5 V and Iout1 = 6 A
- CH2 output: Vout2 = 3.3 V and Iout2 = 7 A

### Step 2. Determine the Value of Voltage Divider Resistors

The output voltage is determined by 2-V internal voltage reference and the resistor dividers (R1 and R2/ R4 and R5). To achieve higher efficiency at light load condition, for 5 V output, select R2 = 100 kΩ and R1 = 150kΩ for 3.3V output R5 = 200 kΩ and R4 = 130 kΩ. Determine R1 using Equation 5. (for 3.3 V, replace R1 with R4 and R2 with R5). For applications where signal-to-noise performance is more valuable than light load efficiency, set R2 (R5) to 10kΩ.

$$R1 = \frac{(V_{OUT} - 0.5 \times V_{RIPPLE} - 2.0)}{2.0} \times R2 \quad (5)$$

### Step 3. Determine Inductance and Choose the Inductor

Smaller inductance yields better transient performance but the consequence is larger ripple and lower efficiency. Larger value has the opposite characteristics. It is the common practice to limit the inductor ripple current to 25% to 50% of the maximum output current. In this case, use 50% at VIN = 20 V.

$$L1 = \frac{1}{I_{IND(ripple)} \times f_{SW(CH1)}} \times \frac{(V_{IN(max)} - V_{OUT}) \times V_{OUT}}{V_{IN(max)}} = 3.13 \mu H \quad (6)$$

Where

- IIND(ripple) = 6 A x 0.5, VOUT = 5 V. VIN(MAX) = 20 V, fSW(CH2) = 400 kHz

$$L2 = \frac{1}{I_{IND(ripple)} \times f_{SW(CH2)}} \times \frac{(V_{IN(max)} - V_{OUT}) \times V_{OUT}}{V_{IN(max)}} = 1.66 \mu H \quad (7)$$

Where

- IIND(ripple) = 7 A x 0.5, VOUT = 3.3 V. VIN(MAX) = 20 V, fSW(CH2) = 475 kHz

For this design, L1 = 3.3 μH and L2 = 2.2 μH are chosen.

#### Step 4. Choose Output Capacitor(s)

For the loop stability, the 0 dB frequency,  $f_0$ , defined in Equation 8 must be lower than 1/4 of the switching frequency (entire  $V_{IN}$  range).

$$f_0 = \frac{1}{2\pi \times ESR \times C_O} \leq \frac{f_{SW}}{4} \quad (8)$$

Determine ESR to meet required ripple voltage below for better jitter performance. A quick approximation is as shown in Equation 9.

$$ESR = \frac{V_{OUT} \times 20[mV] \times (1-D)}{2[V] \times I_{IND(Ripple)}} = \frac{20[mV] \times L \times f_{SW}}{2[V]} \quad (9)$$

where

- D as the duty-cycle factor
- the required output ripple voltage slope is approximately 20 mV per  $t_{SW}$  (switching period) in terms of VFB terminal

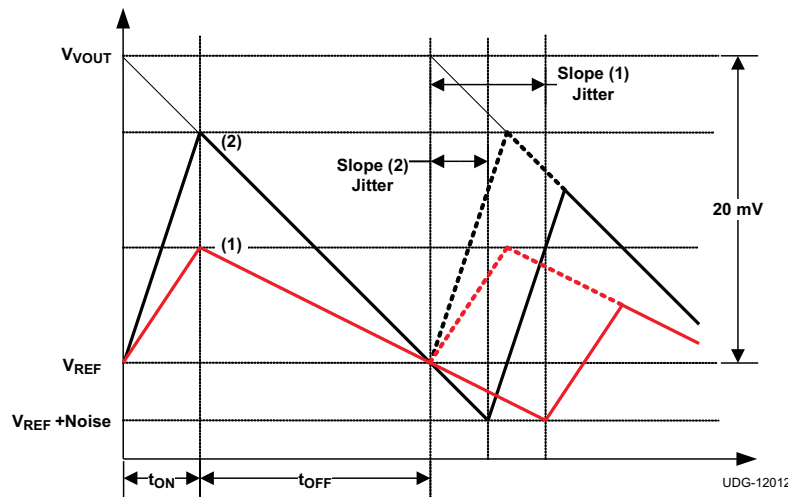

Figure 7. Ripple Voltage Slope and Jitter Performance

This design uses 2 x 220  $\mu$ F (35 m $\Omega$ ) for each output.

#### Step 5. Determine Over Current Limit (OCL) Setting Resistors

Use Equation 10 to determine the over current limit setting resistor ( $R_3$ /  $R_6$ ) which is connected from CS1/CS2 to GND.

$$R_{CS} = \frac{8}{I_{CS}} \times \left[ (I_{OCL(DC)} - I_{IND(ripple)} \times 0.5) \times R_{DS(ON)} - 1mV \right] \quad (10)$$

Confirm CS voltage is within the range of 0.2 V to 2 V over all operation temperature using Equation 11.

$$V_{CS} = R_{CS} \times I_{CS} \left[ (25^\circ C - T_A) \times TC_{CS} \times 10^{-6} + 1 \right] \quad (11)$$

Where

- $T_A$  is an operation temperature

Confirm inductor ripple current is less than half of OCL (valley) using Equation 12

$$I_{IND(ripple)} < \frac{I_{OCL(VALLEY)}}{2} = \frac{\left( \frac{R_{CS} \times I_{CS}}{8} + 1mV \right)}{2 \times R_{DS(ON)}} \quad (12)$$

This design uses CSD87330Q3D (low-side  $R_{DS(ON)}$  typ = 4.7 m $\Omega$ ) and  $R_3$  ( $R_{CS} - CH1$ ) = 6.19 k $\Omega$ ,  $R_6$  ( $R_{CS} - CH2$ ) = 6.65 k $\Omega$ .

### Step 6. Select Decoupling Capacitors

Use ceramic capacitors with a value of 4.7  $\mu\text{F}$  or larger (X5R grade or better) for C5 (VREG5) and C6 (VREG3). For the  $V_{\text{IN}}$  input capacitors (C1 and C2), 2 x 10  $\mu\text{F}$  (1206, 25V, X5R) MLCC per channel is used in the design. Tighter tolerances and higher voltage ratings are always appreciated.

### Step 7. Peripheral Components

For high-side N-channel MOSFET drive circuit, connect boot strap capacitor between  $\text{VBSTx}$  and  $\text{SWx}$ . To control gate driver strength, adding a resistor (reserved space) is recommended. This design uses 0.1  $\mu\text{F}$  (C7 and C8), 0  $\Omega$  (R7 and R8), 6.8  $\Omega$  (R9) and 8.2  $\Omega$  (R10).

### Step 8. Charge Pump Design

Figure 6 shows a circuit design without an external charge pump. Add R11 = 200 $\Omega$  from VCLK to GND to disable VCLK signal. Figure 8 shows the design with an external charge pump. D1 (4-in 1 Diode: BAS40DW-04) should be tied to the 5V switcher output and 4 x 0.1  $\mu\text{F}$  (C9, C10, C11 and C12) is used.

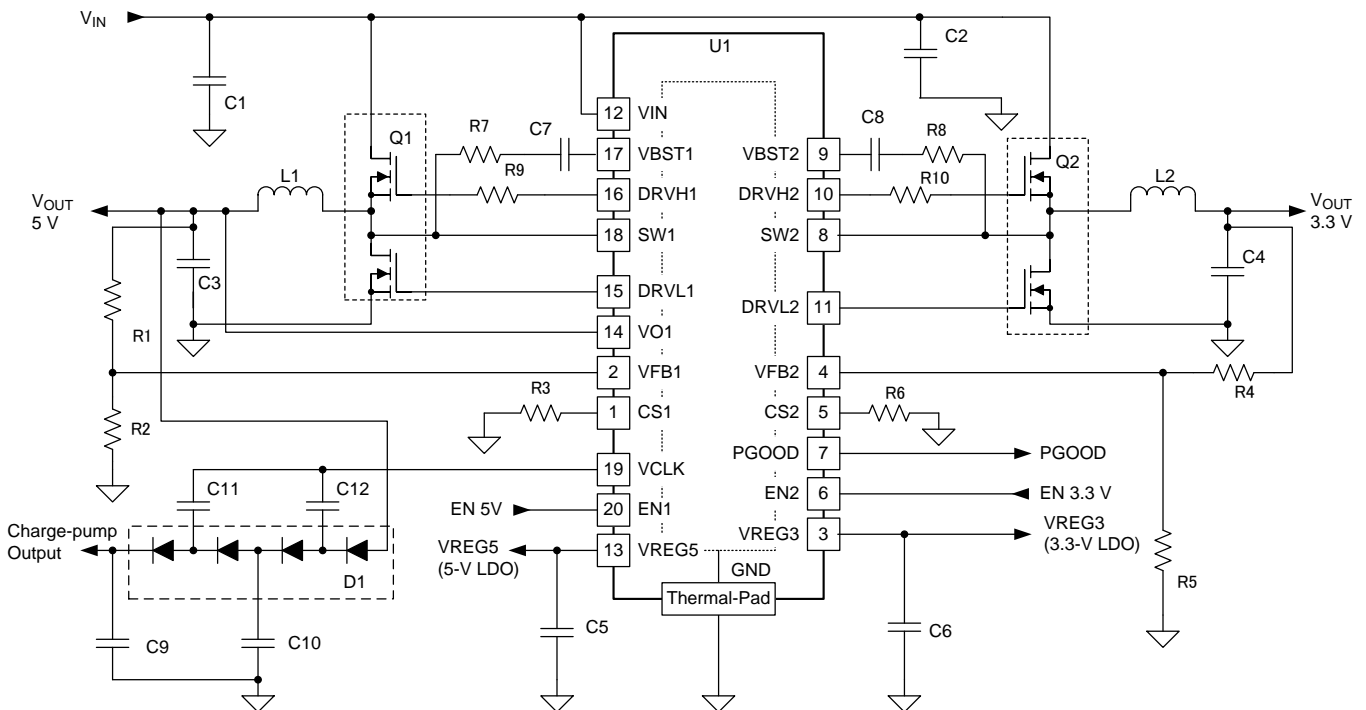

Figure 8. Application Schematic (with Charge pump)

## Layout Considerations

Good layout is essential for stable power supply operation. Follow these guidelines for an efficient PCB layout.

### Placement

- Place voltage setting resistors close to the device pins.
- Place bypass capacitors for VREG5 and VREG3 close to the device pins.

### Routing (Sensitive analog portion)

- Use small copper space for VFBx. There are short and narrow traces to avoid noise coupling.
- Connect VFB resistor trace to the positive node of the output capacitor. Routing inner layer away from power traces is recommended.
- Use short and wide trace from VFB resistor to vias to GND (internal GND plane).

### Routing (Power portion)

- Use wider/shorter traces of DRVL for low-side gate drivers to reduce stray inductance.
- Use the parallel traces of SW and DRVH for high-side MOSFET gate drive in a same layer or on adjoint layers, and keep them away from DRVL.
- Use wider/ shorter traces between the source terminal of the high-side MOSFET and the drain terminal of the low-side MOSFET
- Thermal pad is the GND terminal of this device. Five or more vias with 0.33-mm (13-mils) diameter connected from the thermal pad to the internal GND plane should be used to have strong GND connection and help heat dissipation.

TYPICAL CHARACTERISTICS

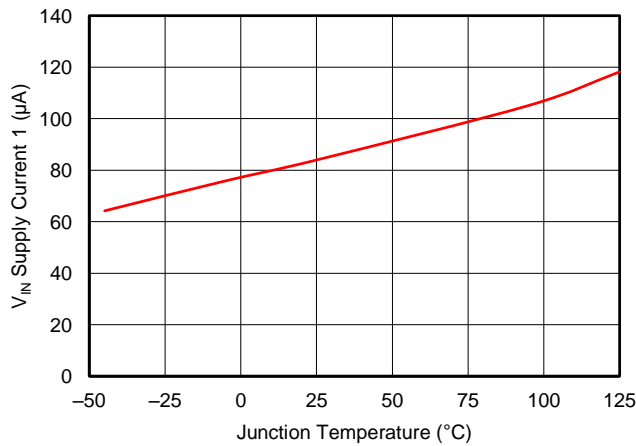

Figure 9. VIN Supply Current 1 vs. Junction Temperature

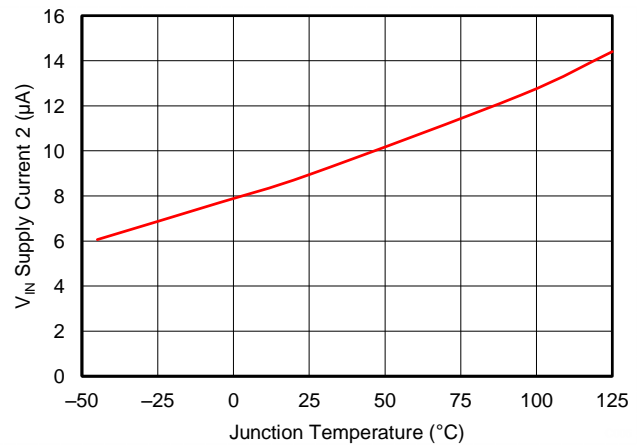

Figure 10. VIN Supply Current 2 vs. Junction Temperature

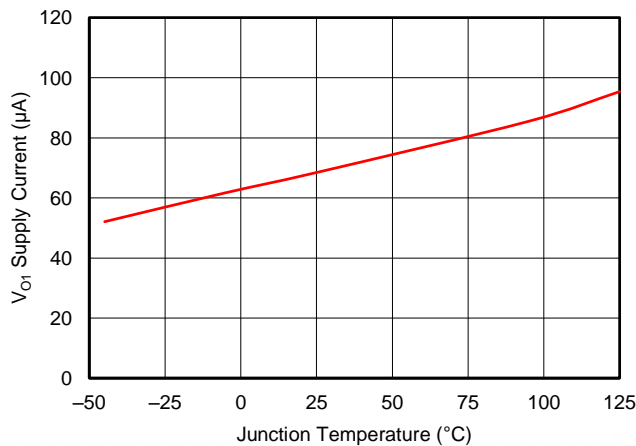

Figure 11. VO1 Supply Current 1 vs. Junction Temperature

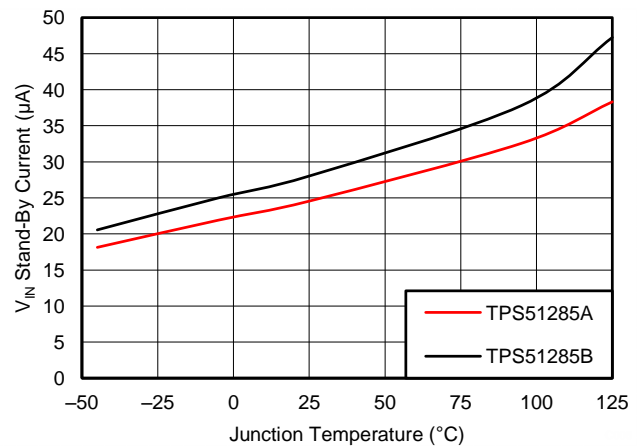

Figure 12. VIN Stand-By Current vs. Junction Temperature

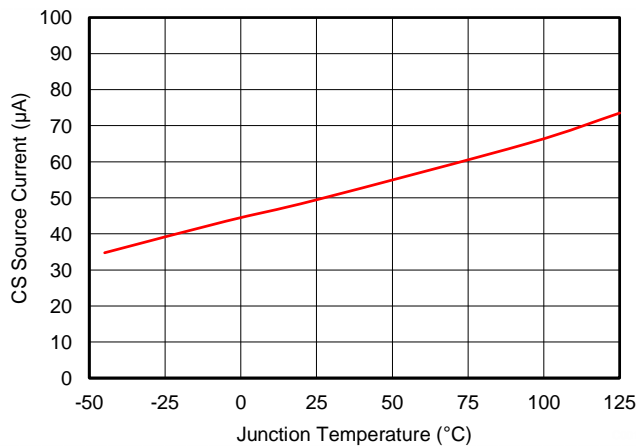

Figure 13. CS Source Current vs. Junction Temperature

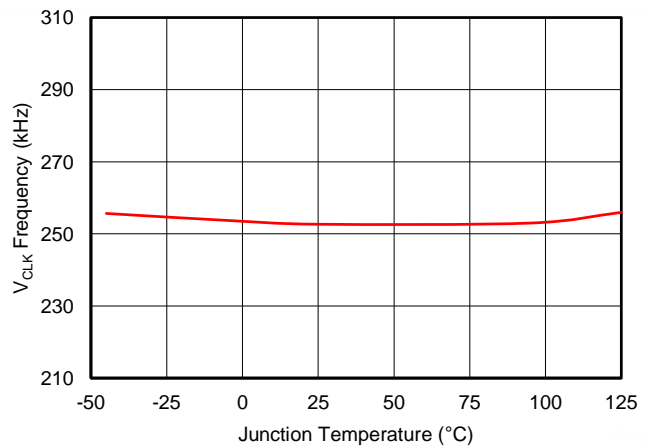

Figure 14. Clock Frequency vs. Junction Temperature

TYPICAL CHARACTERISTICS (continued)

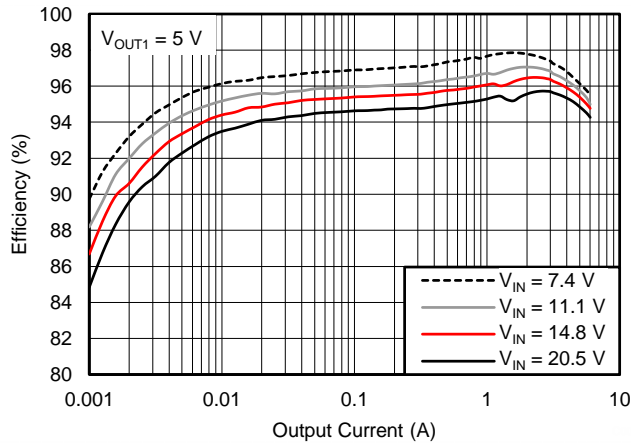

Figure 15. Efficiency vs. Output Current

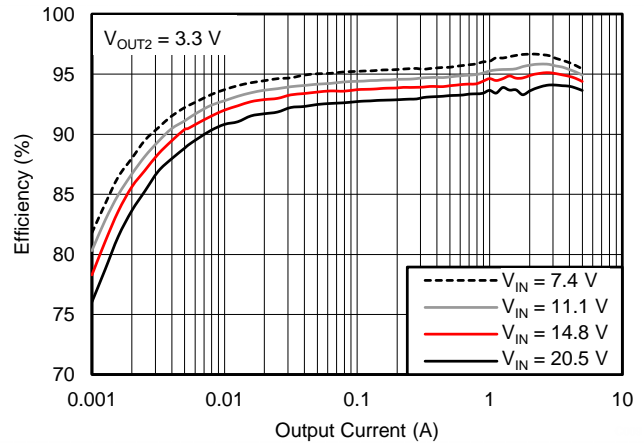

Figure 16. Efficiency vs. Output Current

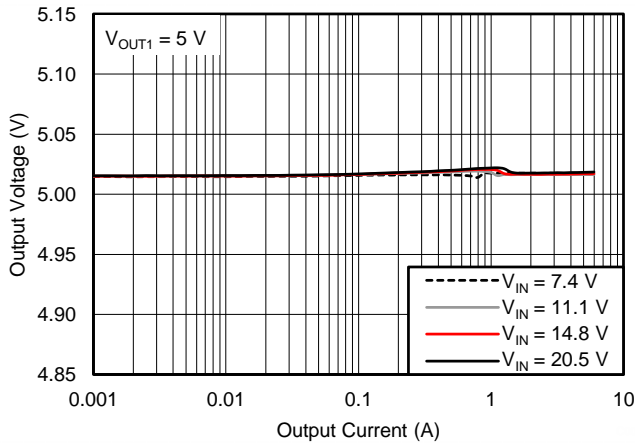

Figure 17. Load Regulation

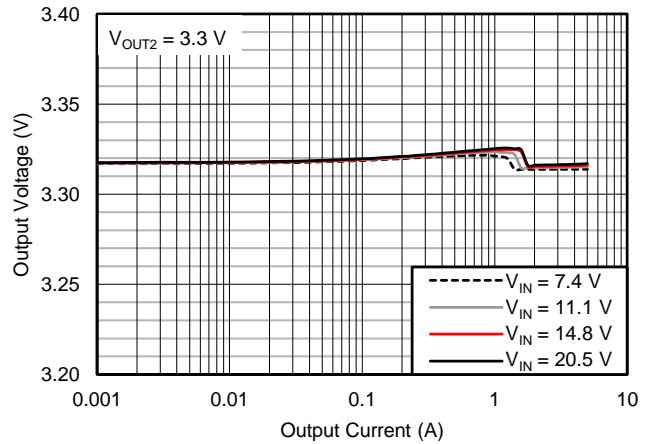

Figure 18. Load Regulation

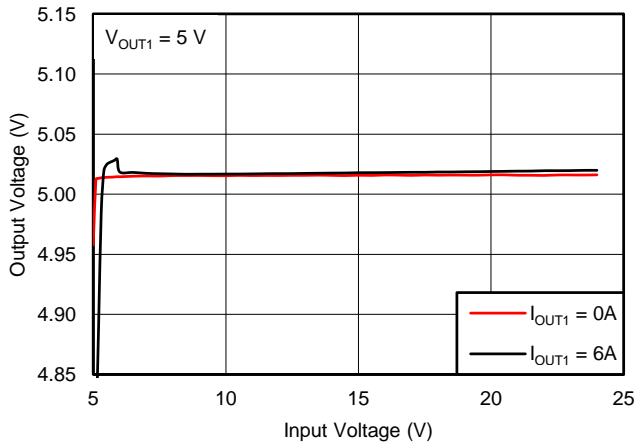

Figure 19. Line Regulation

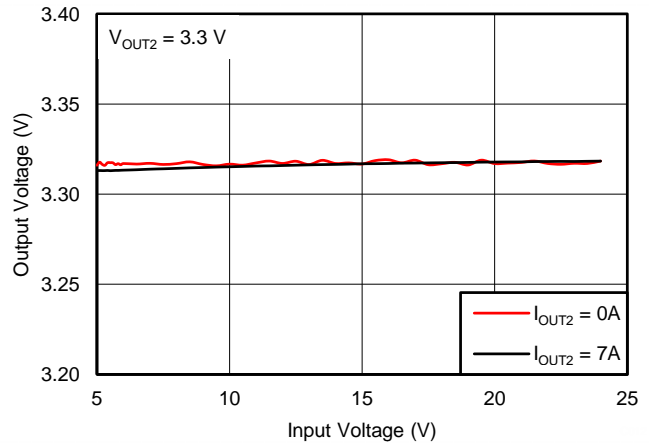

Figure 20. Line Regulation

TYPICAL CHARACTERISTICS (continued)

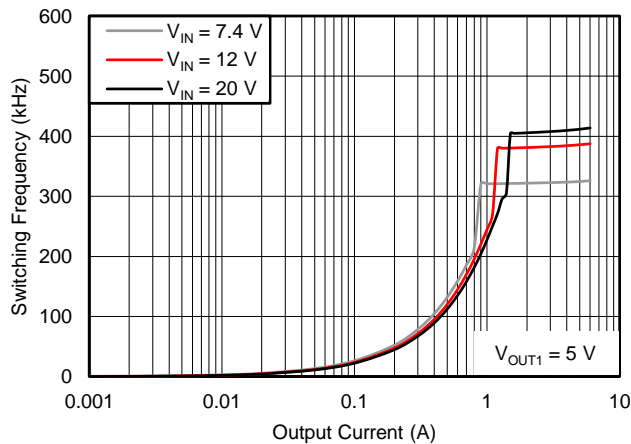

Figure 21. Switching Frequency vs. Output Current

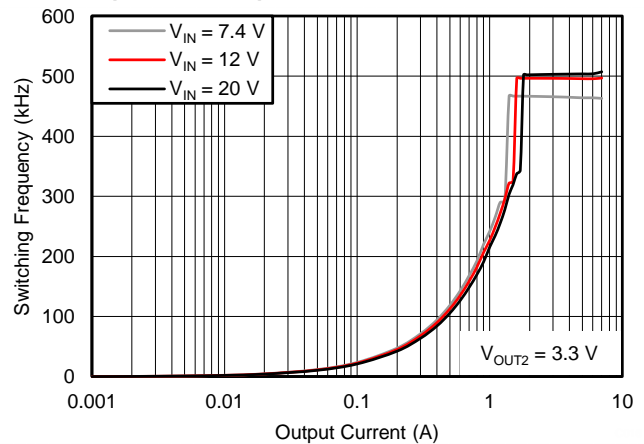

Figure 22. Switching Frequency vs. Output Current

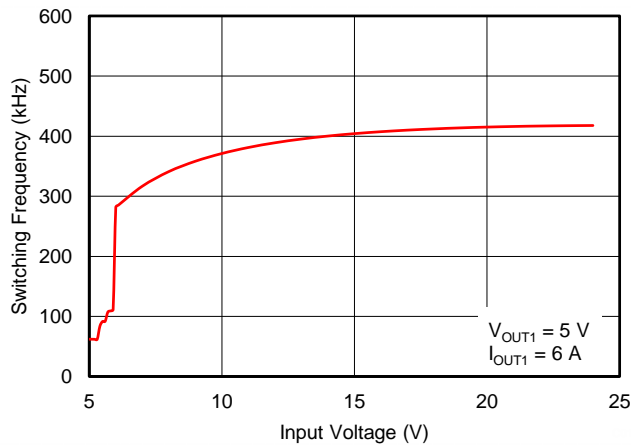

Figure 23. Switching Frequency vs. Input Voltage

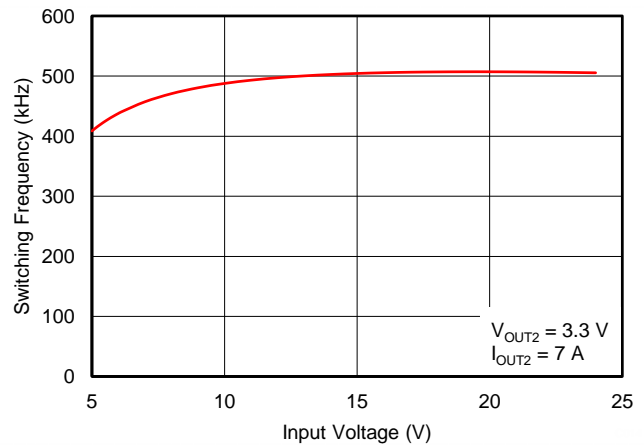

Figure 24. Switching Frequency vs. Input Voltage

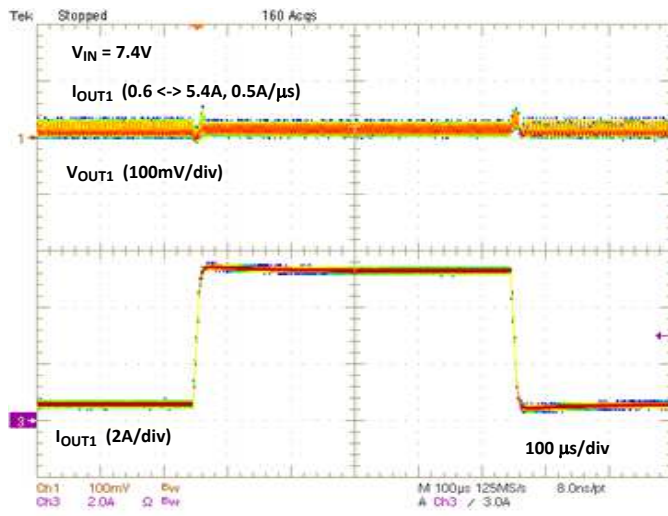

Figure 25. Load Transient

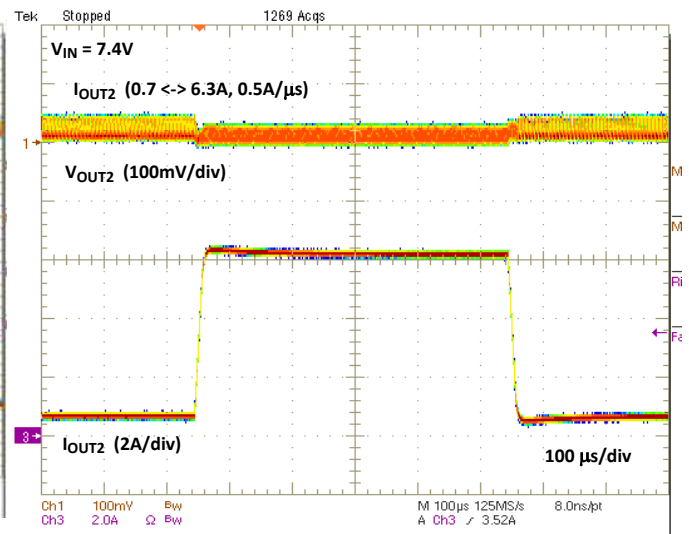

Figure 26. Load Transient

### TYPICAL CHARACTERISTICS (continued)

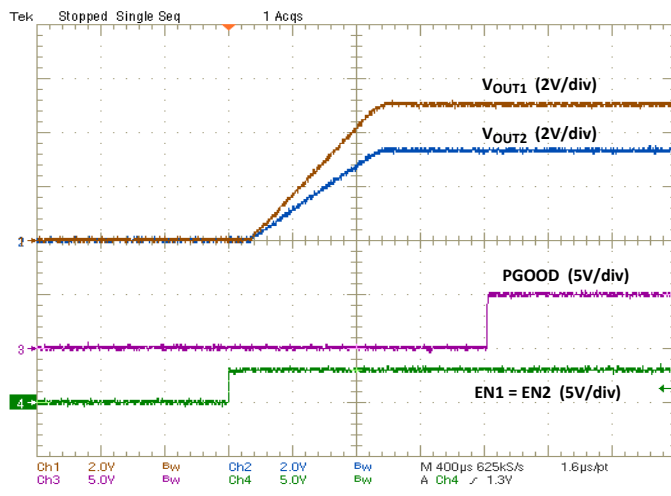

Figure 27. Start-Up

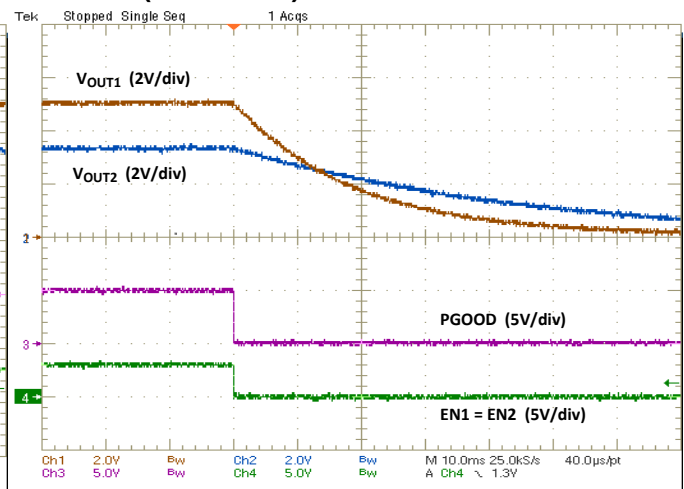

Figure 28. Output Discharge

**PACKAGING INFORMATION**

Orderable Device	Status (1)	Package Type	Package Drawing	Pins	Package Qty	Eco Plan (2)	Lead finish/ Ball material (6)	MSL Peak Temp (3)	Op Temp (°C)	Device Marking (4/5)	Samples
TPS51285ARUKR	ACTIVE	WQFN	RUK	20	3000	RoHS & Green	NIPDAU	Level-2-260C-1 YEAR	-40 to 85	1285A	<a href="#">Samples</a>
TPS51285ARUKT	ACTIVE	WQFN	RUK	20	250	RoHS & Green	NIPDAU	Level-2-260C-1 YEAR	-40 to 85	1285A	<a href="#">Samples</a>
TPS51285BRUKR	ACTIVE	WQFN	RUK	20	3000	RoHS & Green	NIPDAU	Level-2-260C-1 YEAR	-40 to 85	1285B	<a href="#">Samples</a>
TPS51285BRUKT	ACTIVE	WQFN	RUK	20	250	RoHS & Green	NIPDAU	Level-2-260C-1 YEAR	-40 to 85	1285B	<a href="#">Samples</a>

(1) The marketing status values are defined as follows:

**ACTIVE:** Product device recommended for new designs.

**LIFEBUY:** TI has announced that the device will be discontinued, and a lifetime-buy period is in effect.

**NRND:** Not recommended for new designs. Device is in production to support existing customers, but TI does not recommend using this part in a new design.

**PREVIEW:** Device has been announced but is not in production. Samples may or may not be available.

**OBSOLETE:** TI has discontinued the production of the device.

(2) **RoHS:** TI defines "RoHS" to mean semiconductor products that are compliant with the current EU RoHS requirements for all 10 RoHS substances, including the requirement that RoHS substance do not exceed 0.1% by weight in homogeneous materials. Where designed to be soldered at high temperatures, "RoHS" products are suitable for use in specified lead-free processes. TI may reference these types of products as "Pb-Free".

**RoHS Exempt:** TI defines "RoHS Exempt" to mean products that contain lead but are compliant with EU RoHS pursuant to a specific EU RoHS exemption.

**Green:** TI defines "Green" to mean the content of Chlorine (Cl) and Bromine (Br) based flame retardants meet JS709B low halogen requirements of <=1000ppm threshold. Antimony trioxide based flame retardants must also meet the <=1000ppm threshold requirement.

(3) MSL, Peak Temp. - The Moisture Sensitivity Level rating according to the JEDEC industry standard classifications, and peak solder temperature.

(4) There may be additional marking, which relates to the logo, the lot trace code information, or the environmental category on the device.

(5) Multiple Device Markings will be inside parentheses. Only one Device Marking contained in parentheses and separated by a "-" will appear on a device. If a line is indented then it is a continuation of the previous line and the two combined represent the entire Device Marking for that device.

(6) Lead finish/Ball material - Orderable Devices may have multiple material finish options. Finish options are separated by a vertical ruled line. Lead finish/Ball material values may wrap to two lines if the finish value exceeds the maximum column width.

**Important Information and Disclaimer:**The information provided on this page represents TI's knowledge and belief as of the date that it is provided. TI bases its knowledge and belief on information provided by third parties, and makes no representation or warranty as to the accuracy of such information. Efforts are underway to better integrate information from third parties. TI has taken and

continues to take reasonable steps to provide representative and accurate information but may not have conducted destructive testing or chemical analysis on incoming materials and chemicals. TI and TI suppliers consider certain information to be proprietary, and thus CAS numbers and other limited information may not be available for release.

In no event shall TI's liability arising out of such information exceed the total purchase price of the TI part(s) at issue in this document sold by TI to Customer on an annual basis.

# RUK0020B

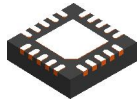

# PACKAGE OUTLINE

## WQFN - 0.8 mm max height

PLASTIC QUAD FLATPACK - NO LEAD

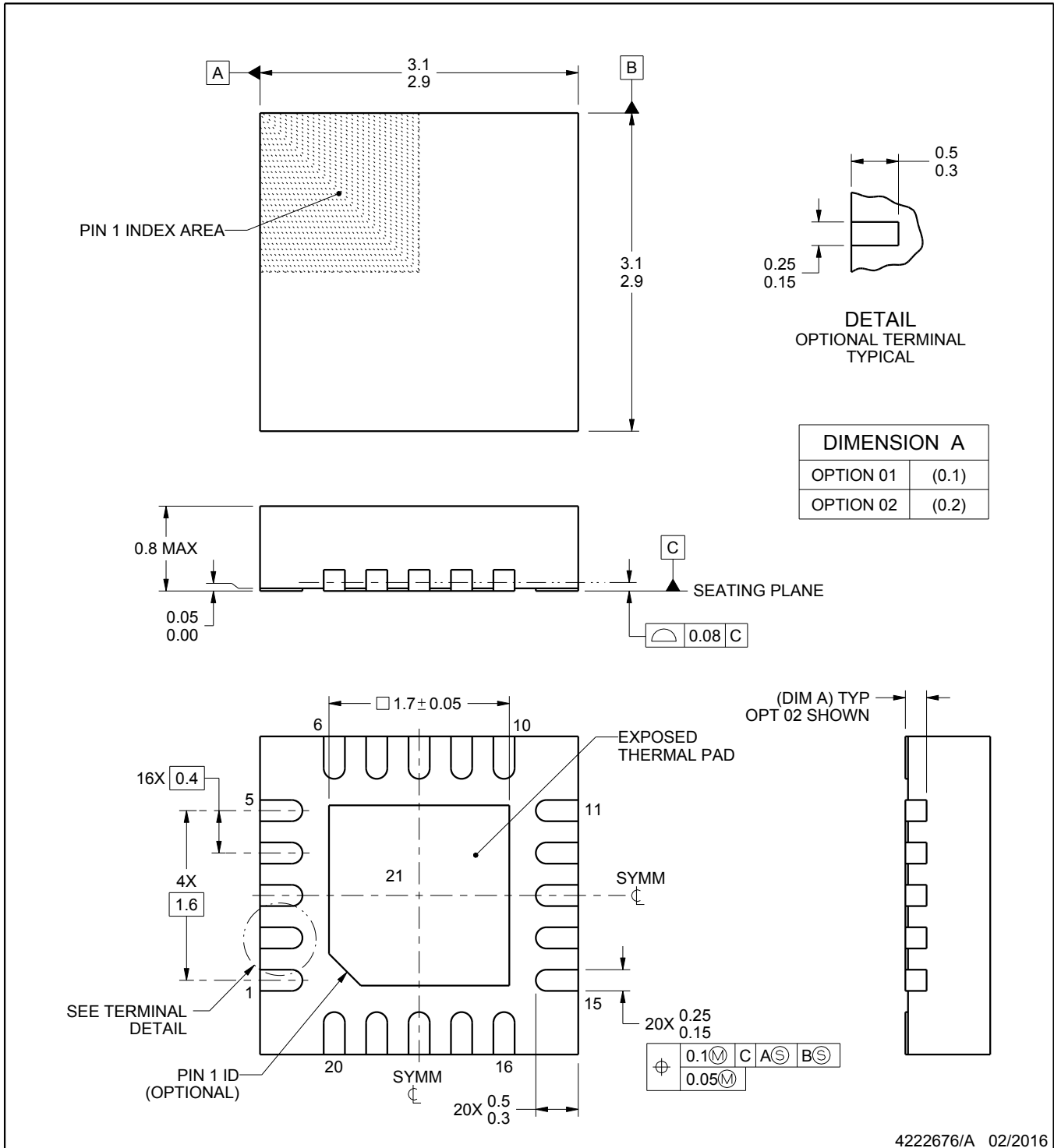

**NOTES:**

1. All linear dimensions are in millimeters. Any dimensions in parenthesis are for reference only. Dimensioning and tolerancing per ASME Y14.5M.
2. This drawing is subject to change without notice.
3. The package thermal pad must be soldered to the printed circuit board for thermal and mechanical performance.

# EXAMPLE BOARD LAYOUT

RUK0020B

WQFN - 0.8 mm max height

PLASTIC QUAD FLATPACK - NO LEAD

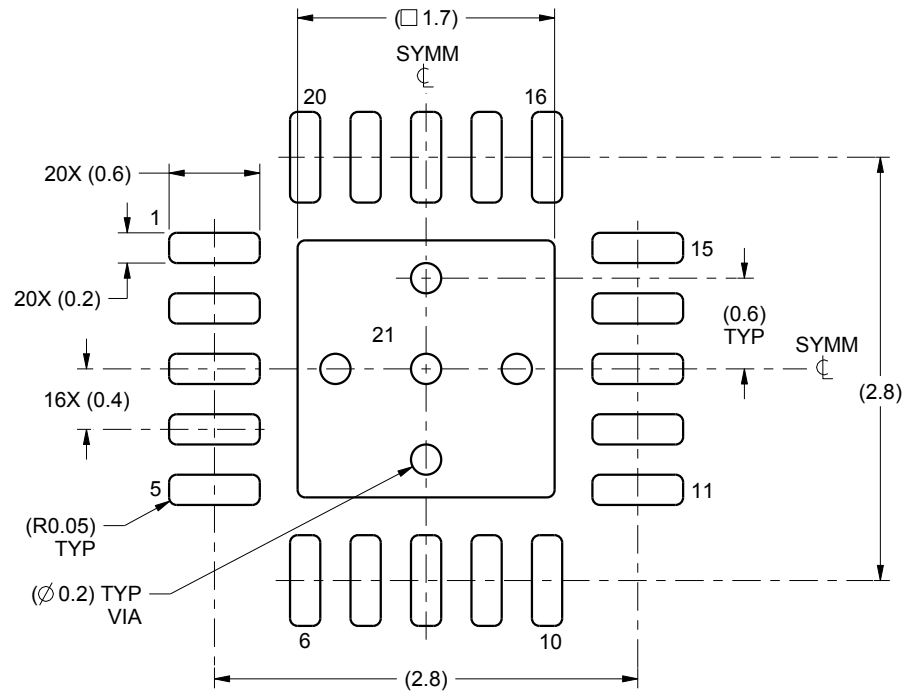

LAND PATTERN EXAMPLE  
SCALE:20X

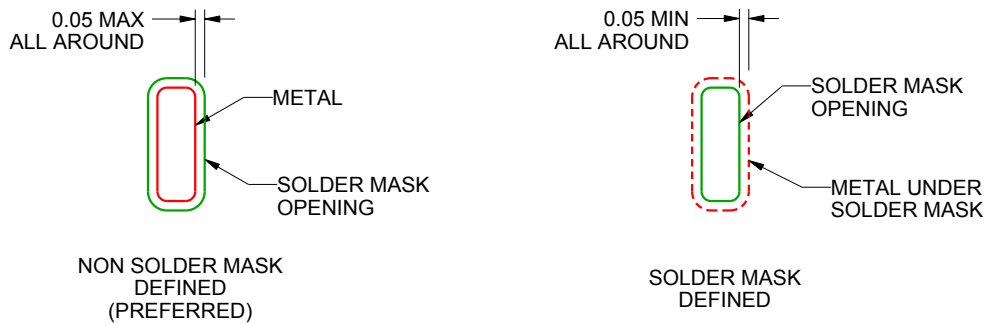

SOLDER MASK DETAILS

4222676/A 02/2016

NOTES: (continued)

4. This package is designed to be soldered to a thermal pad on the board. For more information, see Texas Instruments literature number SLUA271 ([www.ti.com/lit/slua271](http://www.ti.com/lit/slua271)).
5. Vias are optional depending on application, refer to device data sheet. If any vias are implemented, refer to their locations shown on this view. It is recommended that vias under paste be filled, plugged or tented.

# EXAMPLE STENCIL DESIGN

RUK0020B

WQFN - 0.8 mm max height

PLASTIC QUAD FLATPACK - NO LEAD

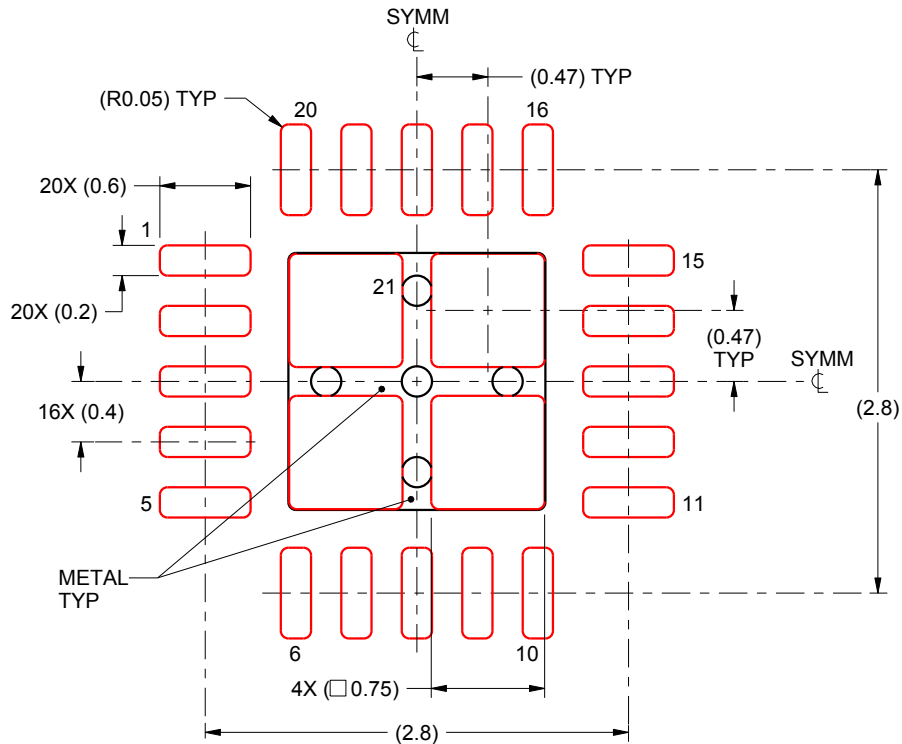

## SOLDER PASTE EXAMPLE BASED ON 0.1 mm THICK STENCIL

EXPOSED PAD 21:  
78% PRINTED SOLDER COVERAGE BY AREA UNDER PACKAGE  
SCALE:20X

4222676/A 02/2016

NOTES: (continued)

6. Laser cutting apertures with trapezoidal walls and rounded corners may offer better paste release. IPC-7525 may have alternate design recommendations.

## 重要声明和免责声明

TI“按原样”提供技术和可靠性数据（包括数据表）、设计资源（包括参考设计）、应用或其他设计建议、网络工具、安全信息和其他资源，不保证没有瑕疵且不做任何明示或暗示的担保，包括但不限于对适销性、某特定用途方面的适用性或不侵犯任何第三方知识产权的暗示担保。

这些资源可供使用 TI 产品进行设计的熟练开发人员使用。您将自行承担以下全部责任：(1) 针对您的应用选择合适的 TI 产品，(2) 设计、验证并测试您的应用，(3) 确保您的应用满足相应标准以及任何其他功能安全、信息安全、监管或其他要求。

这些资源如有变更，恕不另行通知。TI 授权您仅可将这些资源用于研发本资源所述的 TI 产品的应用。严禁对这些资源进行其他复制或展示。您无权使用任何其他 TI 知识产权或任何第三方知识产权。您应全额赔偿因在这些资源的使用中对 TI 及其代表造成的任何索赔、损害、成本、损失和债务，TI 对此概不负责。

TI 提供的产品受 [TI 的销售条款](#) 或 [ti.com](#) 上其他适用条款/TI 产品随附的其他适用条款的约束。TI 提供这些资源并不会扩展或以其他方式更改 TI 针对 TI 产品发布的适用的担保或担保免责声明。

TI 反对并拒绝您可能提出的任何其他或不同的条款。

邮寄地址：Texas Instruments, Post Office Box 655303, Dallas, Texas 75265  
Copyright © 2021，德州仪器 (TI) 公司