

LM48580 Boomer™ 音频功率放大器系列高效率 H 类、高电压、触觉压电驱动器/陶瓷扬声器驱动器

1 特性

- H 类驱动器
- 集成升压转换器
- 桥接式负载输出
- 差动输入
- 三个引脚可编程增益
- 低电源电流
- 最小外部组件数量
- 低功耗关断
- 热过载保护
- 采用节省空间的 12 凸点 DSBGA 封装

2 应用

- 触摸屏智能手机
- 平板电脑
- 便携式电子设备
- MP3 播放器
- 主要规格:
 - 输出电压 $V_{DD} = 3.6V$,
 $R_L = 6\mu F + 10\Omega$, $THD+N \leq 1\%$
 - $30V_{P-P}$ (典型值)
 - 3.6V 时的静态电源电流
 - 2.7mA (典型值)
 - $25V_{P-P}$ 时的功率损耗
 - 800mW (典型值)
 - 关断电流
 - 0.1 μA (典型值)

3 说明

LM48580 是一款全差动、高压驱动器，适用于便携式多媒体设备的压电式传动器和陶瓷扬声器。作为 TI 的 Powerwise™ 产品系列的一部分，LM48580 H 类架构与传统 AB 类放大器相比，可大幅节省功耗。该器件提供 $30V_{P-P}$ 输出驱动，同时仅消耗 15mW 的静态功率。

LM48580 是一款单电源驱动器，带有一个集成型升压转换器，该升压转换器支持器件通过 3.6V 的单电源提供 $30V_{P-P}$ 的输出。

LM48580 具有三种引脚可编程增益设置和一个低功耗关断模式，可将静态电流消耗降至 0.1 μA 。LM48580 采用超小型 12 凸点 DSBGA 封装。

器件信息(1)

器件型号	封装	封装尺寸 (标称值)
LM48580	DSBGA	2.00mm x 1.80mm

(1) 如需了解所有可用封装，请参阅数据表末尾的可订购产品附录。

典型应用

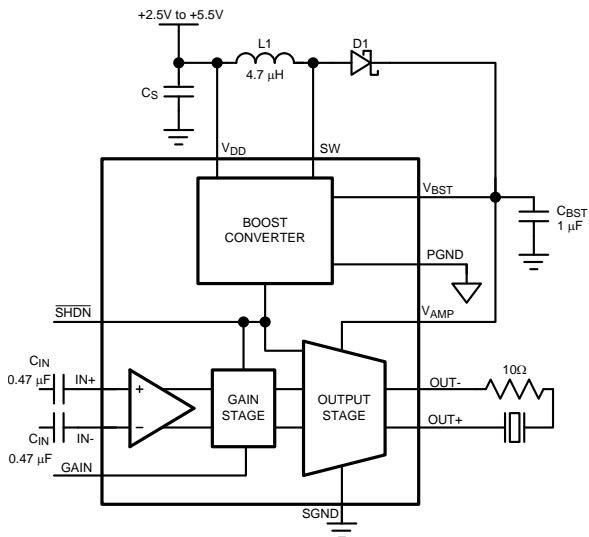

Copyright © 2018, Texas Instruments Incorporated



目录

1	特性	1	8.4	Device Functional Modes	10
2	应用	1	9	Application and Implementation	11
3	说明	1	9.1	Application Information	11
4	修订历史记录	2	9.2	Typical Application	11
5	Pin Configuration and Functions	3	10	Power Supply Recommendations	12
6	Specifications	4	11	Layout	13
6.1	Absolute Maximum Ratings	4	11.1	Layout Guidelines	13
6.2	ESD Ratings	4	11.2	Layout Example	13
6.3	Recommended Operating Conditions	4	12	器件和文档支持	14
6.4	Thermal Information	4	12.1	器件支持	14
6.5	Electrical Characteristics: $V_{DD} = 3.6\text{ V}$	5	12.2	接收文档更新通知	14
6.6	Typical Performance Characteristics	6	12.3	社区资源	14
7	Parameter Measurement Information	8	12.4	商标	14
8	Detailed Description	9	12.5	静电放电警告	14
8.1	Overview	9	12.6	Glossary	14
8.2	Functional Block Diagram	9	13	机械、封装和可订购信息	14
8.3	Feature Description	9			

4 修订历史记录

注：之前版本的页码可能与当前版本有所不同。

Changes from Revision A (May 2013) to Revision B	Page
• 添加了器件信息表、ESD 表、热性能信息表、参数测量信息、特性说明、器件功能模式、电源建议、布局部分、器件和文档支持以及机械、封装和可订购信息	1
• Deleted the <i>Demoboard Bill of Materials</i> section	12
• Deleted the <i>Demo Board Schematic</i> section	12

Changes from Original (February 2010) to Revision A	Page
• 已将美国国家半导体数据表的版面布局更改为 TI 格式。	1

5 Pin Configuration and Functions

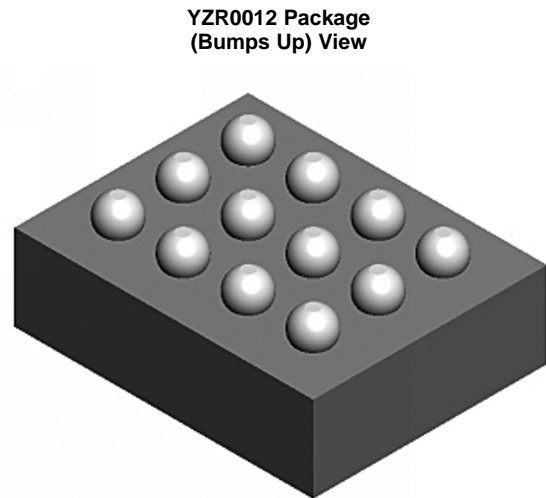
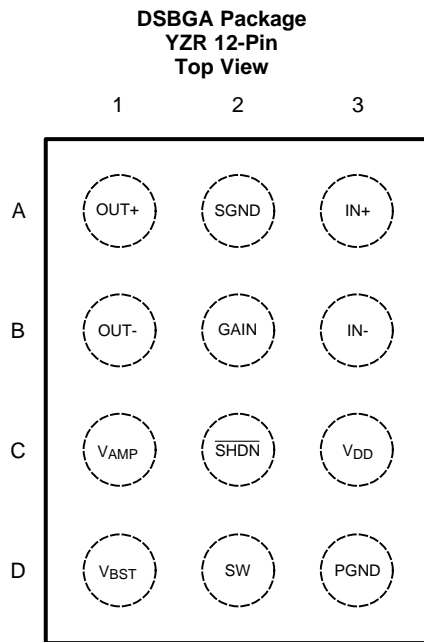

Pin Functions

Bump	Name	Description
A1	OUT+	Amplifier Non-Inverting Output
A2	SGND	Amplifier Ground
A3	IN+	Amplifier Non-Inverting Input
B1	OUT-	Amplifier Inverting Output
B2	GAIN	Gain Select: GAIN = float: A _V = 18dB GAIN = GND: A _V = 24dB GAIN = V _{DD} : A _V = 30dB
B3	IN-	Amplifier Inverting Input
C1	V _{AMP}	Amplifier Supply Voltage. Connect to V _{BST}
C2	$\overline{\text{SHDN}}$	Active Low Shutdown. Drive $\overline{\text{SHDN}}$ low to disable device. Connect $\overline{\text{SHDN}}$ to V _{DD} for normal operation.
C3	V _{DD}	Power Supply
D1	V _{BST}	Boost Converter Output
D2	SW	Boost Converter Switching Node
D3	PGND	Boost Converter Ground

6 Specifications

6.1 Absolute Maximum Ratings

 over operating free-air temperature range (unless otherwise noted)⁽¹⁾⁽²⁾

	MIN	MAX	UNIT
Supply Voltage		6	V
SW Voltage		25	V
VBST Voltage		21	V
V _{AMP}		17	V
Input Voltage	-0.3	V _{DD} + 0.3	V
Storage temperature, T _{stg}	-65	150	°C
Junction Temperature		150	°C

- Stresses beyond those listed under *Absolute Maximum Ratings* may cause permanent damage to the device. These are stress ratings only, which do not imply functional operation of the device at these or any other conditions beyond those indicated under *Recommended Operating Conditions*. Exposure to absolute-maximum-rated conditions for extended periods may affect device reliability.
- If Military/Aerospace specified devices are required, please contact the Texas Instruments Sales Office/Distributors for availability and specifications.

6.2 ESD Ratings

		VALUE	UNIT
V _(ESD) Electrostatic discharge	Human-body model (HBM), per ANSI/ESDA/JEDEC JS-001 ⁽¹⁾	±2000	V
	Charged-device model (CDM), per JEDEC specification JESD22-C101 ⁽²⁾	±750	

- JEDEC document JEP155 states that 500-V HBM allows safe manufacturing with a standard ESD control process.
- JEDEC document JEP157 states that 250-V CDM allows safe manufacturing with a standard ESD control process.

6.3 Recommended Operating Conditions

over operating free-air temperature range (unless otherwise noted)

	MIN	NOM	MAX	UNIT
Temperature Range	-40	T _A	85	°C
Supply Voltage	2.5	V _{DD}	5.5	V

6.4 Thermal Information

THERMAL METRIC ⁽¹⁾		LM48580	UNIT
		YZR (DSBGA)	
		12 PINS	
R _{θJA}	Junction-to-ambient thermal resistance	82.1	°C/W
R _{θJC(top)}	Junction-to-case (top) thermal resistance	0.6	°C/W
R _{θJB}	Junction-to-board thermal resistance	20.6	°C/W
ψ _{JT}	Junction-to-top characterization parameter	0.4	°C/W
ψ _{JB}	Junction-to-board characterization parameter	20.7	°C/W
R _{θJC(bot)}	Junction-to-case (bottom) thermal resistance	n/a	°C/W

- For more information about traditional and new thermal metrics, see the [Semiconductor and IC Package Thermal Metrics](#) application report.

6.5 Electrical Characteristics: $V_{DD} = 3.6\text{ V}^{(1)}$

The following specifications apply for $R_L = 6\ \mu\text{F} + 10\ \Omega$, $C_{BST} = 1\ \mu\text{F}$, $C_{IN} = 0.47\ \mu\text{F}$, $A_V = 24\ \text{dB}$ unless otherwise specified. Limits apply for $T_A = 25^\circ\text{C}$.

PARAMETER		TEST CONDITIONS	Min ⁽²⁾	Typ ⁽³⁾	Max ⁽²⁾	Unit
V_{DD}	Supply Voltage Range		2.5		5.5	V
I_{DD}	Quiescent Power Supply Current, $V_{IN} = 0\text{V}$, $R_L = \infty$	$V_{DD} = 3.6\text{V}$		2.7	4	mA
		$V_{DD} = 3\text{V}$		3		mA
P_D	Power Consumption $V_{OUT} = 25V_{P-P}$, $f = 200\ \text{Hz}$	$V_{DD} = 3.6\text{V}$		800		mW
		$V_{DD} = 3\text{V}$		830		mW
I_{SD}	Shutdown Current	Shutdown Enabled		0.5	2	μA
T_{WU}	Wake-up Time	From Shutdown	1	1.4	1.6	ms
V_{OS}	Differential Output Offset Voltage	$V_{DD} = 3.6\ \text{V}$		63	360	mV
A_V	Gain	GAIN = FLOAT	17.5	18	18.5	dB
		GAIN = GND	23.5	24	24.5	dB
		GAIN = V_{DD}	29.5	30	30.5	dB
R_{IN}	Input Resistance		46	52	58	k Ω
R_{IN}	Gain Input Resistance	to GND			575	k Ω
		to V_{DD}			131	k Ω
V_{IN}	Maximum Input Voltage Range	$A_V = 18\text{dB}$			3	V_{P-P}
V_{OUT}	Output Voltage $f = 200\ \text{Hz}$, THD+N = 1%	$V_{DD} = 3.6\ \text{V}$	25	30.5		V_{P-P}
		$V_{DD} = 3\ \text{V}$		30.5		V_{P-P}
	Output Voltage $f = 2\ \text{kHz}$, THD+N = 5%	$V_{DD} = 3.6\ \text{V}$		11		V_{P-P}
		$V_{DD} = 3\ \text{V}$		8.5		V_{P-P}
THD+N	Total Harmonic Distortion + Noise	$V_{OUT} = 25V_{P-P}$, $f = 200\text{Hz}$		0.16%		
PSRR	Power Supply Rejection Ratio $V_{DD} = 3.6\ \text{V} + 200\ \text{mV}_{P-P}$ sine, Inputs AC GND	$f_{RIPPLE} = 217\ \text{Hz}$,		75		dB
		$f_{RIPPLE} = 1\ \text{kHz}$		71		dB
CMRR	Common Mode Rejection Ratio $V_{CM} = 200\text{mV}_{P-P}$ sine	$f_{RIPPLE} = 217\ \text{Hz}$		56		dB
		$f_{RIPPLE} = 1\ \text{kHz}$		55		dB
f_{SW}	Boost Converter Switching Frequency			2.1		MHz
I_{LIMIT}	Boost Converter Current Limit				1100	mA
V_{IH}	Logic High Input Threshold	$\overline{\text{SHDN}}$	1.2			V
V_{IL}	Logic Low Input Threshold	$\overline{\text{SHDN}}$			0.45	V
I_{IN}	Input Leakage Current	$\overline{\text{SHDN}}$		0.1	1	μA

- (1) The *Electrical Characteristics* tables list ensured specifications under the listed *Recommended Operating Conditions* except as otherwise modified or specified by the *Electrical Characteristics Conditions* and/or Notes. Typical specifications are estimations only and are not ensured.
- (2) Datasheet min/max specification limits are specified by design, test, or statistical analysis.
- (3) Typical values represent most likely parametric norms at $T_A = +25^\circ\text{C}$, and at the *Recommended Operation Conditions* at the time of product characterization and are not specified.

6.6 Typical Performance Characteristics

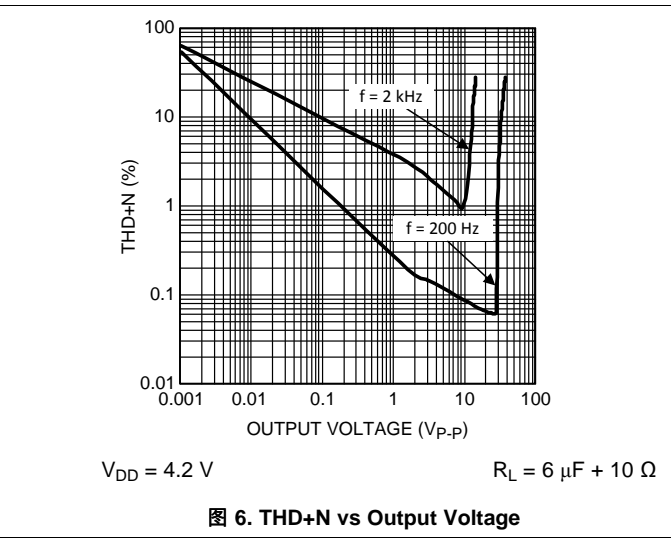
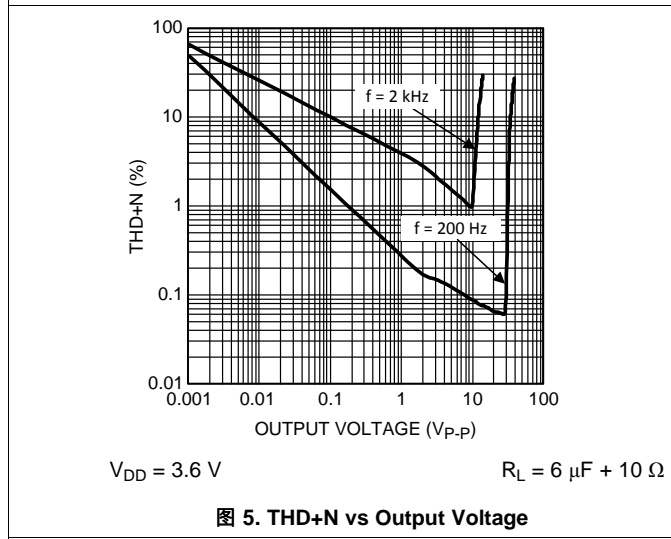
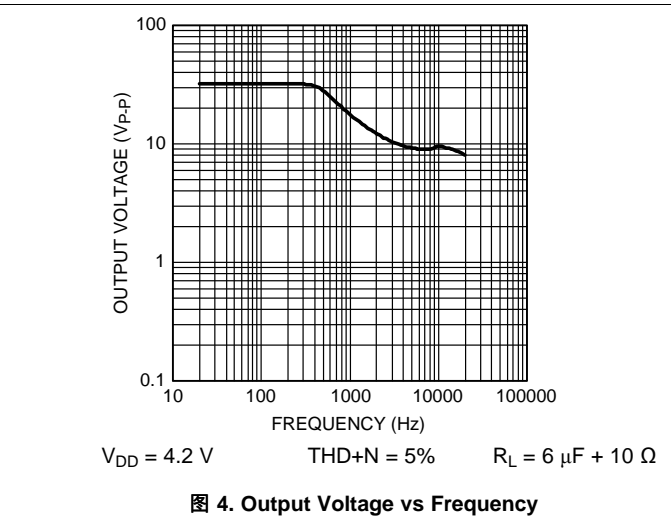
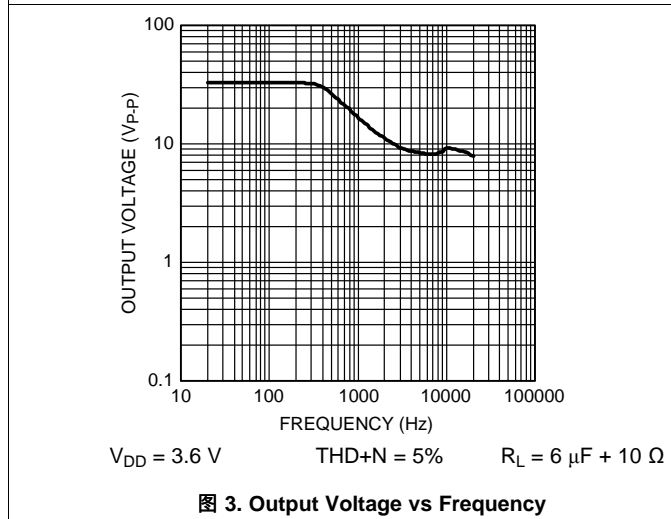
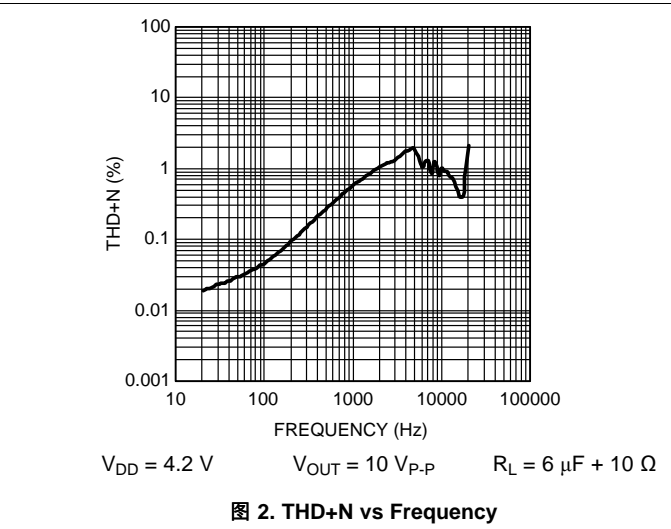
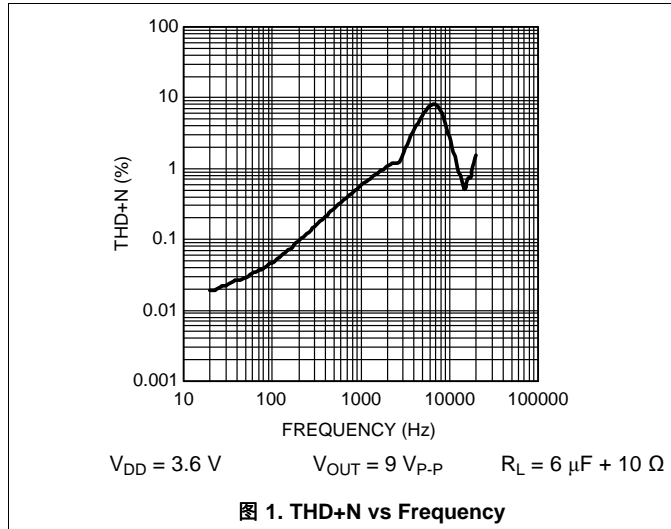

Typical Performance Characteristics (接下页)

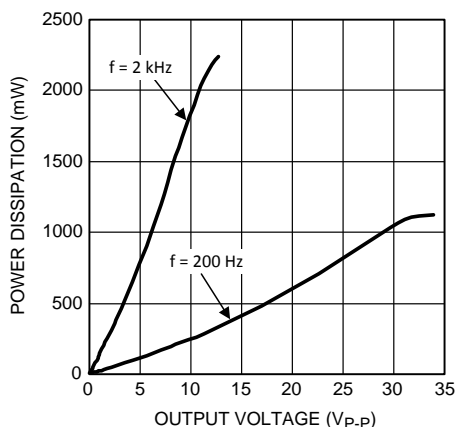

$V_{DD} = 3.6\text{ V}$ $R_L = 6\ \mu\text{F} + 10\ \Omega$

图 7. Power Consumption vs Output Voltage

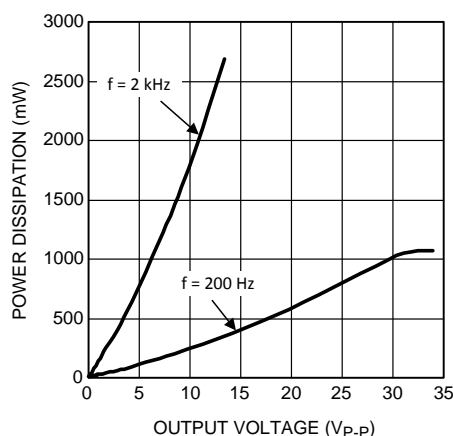

$V_{DD} = 4.2\text{ V}$ $R_L = 6\ \mu\text{F} + 10\ \Omega$

图 8. Power Consumption vs Output Voltage

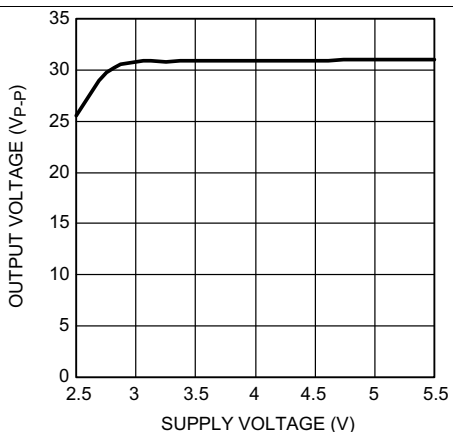

$R_L = 6\ \mu\text{F} + 10\ \Omega$, $f = 200\text{ Hz}$

图 9. Output Voltage vs Supply Voltage

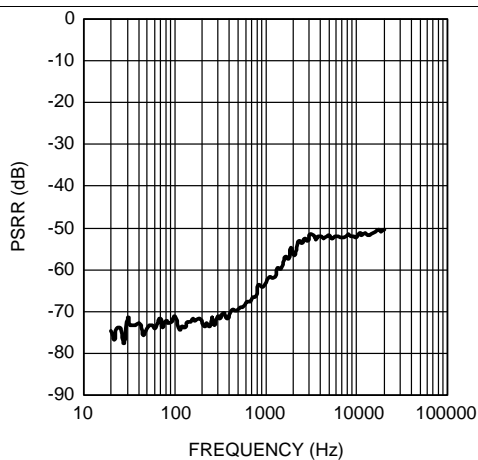

$V_{DD} = 3.6\text{ V}$ $f = 200\text{ Hz}$ $R_L = 6\ \mu\text{F} + 10\ \Omega$,
 $V_{RIPPLE} = 200\text{ mV}_{P-P}$

图 10. PSRR vs Frequency

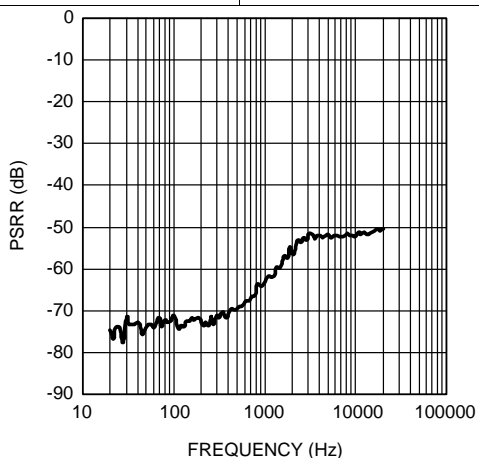

$V_{DD} = 3.6\text{ V}$ $V_{CM} = 1\text{ V}_{P-P}$ $R_L = 6\ \mu\text{F} + 10\ \Omega$

图 11. CMRR vs Frequency

7 Parameter Measurement Information

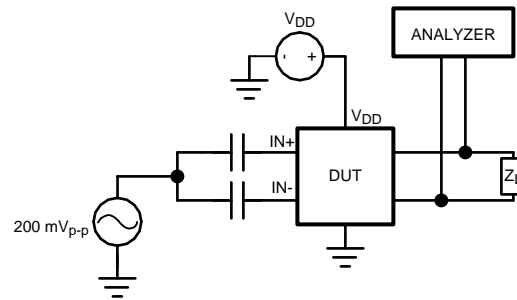

Copyright © 2018, Texas Instruments Incorporated

图 12. PSRR Test Circuit

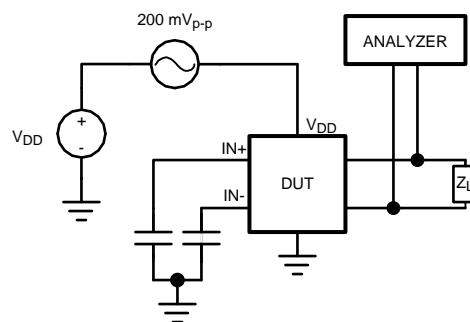

Copyright © 2018, Texas Instruments Incorporated

图 13. CMRR Test Circuit

8 Detailed Description

8.1 Overview

The LM48580 is a fully differential, Class H ceramic element driver for ceramic speakers and haptic actuators. The integrated, high efficiency boost converter dynamically adjusts the amplifier's supply voltage based on the output signal, increasing headroom and improving efficiency compared to a conventional Class AB driver. The fully differential amplifier takes advantage of the increased headroom and bridge-tied load (BTL) architecture, delivering significantly more voltage than a single-ended amplifier.

8.2 Functional Block Diagram

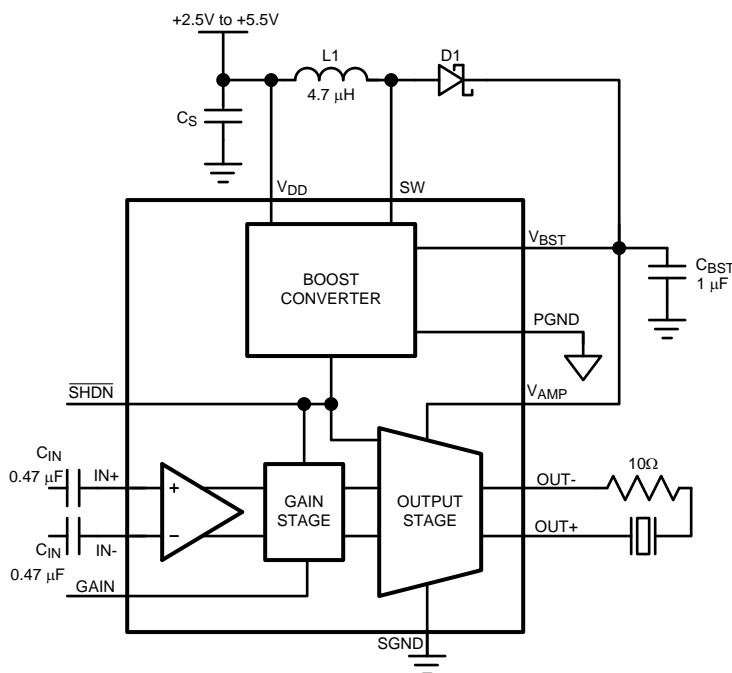

Copyright © 2018, Texas Instruments Incorporated

8.3 Feature Description

8.3.1 Class H Operation

Class H is a modification of another amplifier class (typically Class B or Class AB) to increase efficiency and reduce power dissipation. To decrease power dissipation, Class H uses a tracking power supply that monitors the output signal and adjusts the supply accordingly. When the amplifier output is below $3 V_{P-P}$, the nominal boost voltage is 6 V. As the amplifier output increases above $3 V_{P-P}$, the boost voltage tracks the amplifier output as shown in [Figure 14](#). When the amplifier output falls below $3 V_{P-P}$, the boost converter returns to its nominal output voltage. Power dissipation is greatly reduced compared to conventional Class AB drivers.



图 14. Class H Operation

Feature Description (接下页)

8.3.2 Properties of Piezoelectric Elements

Piezoelectric elements such as ceramic speakers or piezoelectric haptic actuators are capacitive in nature. Due to their capacitive nature, piezoelectric elements appear as low impedance loads at high frequencies (typically above 5 kHz). A resistor in series with the piezoelectric element is required to ensure the amplifier does not see a short at high frequencies.

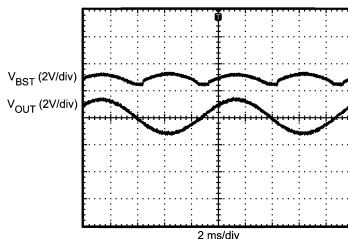
The value of the series resistor depends on the capacitance of the element, the frequency content of the output signal, and the desired frequency response. Higher valued resistors minimize power dissipation at high frequencies, but also impacts the frequency response. This configuration is suited for use with haptic actuators, where the majority of the signal content is typically below 2 kHz. Conversely, lower valued resistors maximize frequency response, while increasing power dissipation at high frequency. This configuration is ideal for ceramic speaker applications, where high frequency audio content needs to be reproduced. Resistor values are typically between 10 Ω and 20 Ω .

8.3.3 Differential Amplifier Explanation

The LM48580 features a fully differential amplifier. A differential amplifier amplifies the difference between the two input signals. A major benefit of the fully differential amplifier is the improved common mode rejection ratio (CMRR) over single ended input amplifiers. The increased CMRR of the differential amplifier reduces sensitivity to ground offset related noise injection, especially important in noisy systems.

8.3.4 Thermal Shutdown

The LM48580 features thermal shutdown that protects the device during thermal overload conditions. When the junction temperature exceeds +160°C, the device is disabled. The LM48580 remains disabled until the die temperature falls below the +160°C and SHDN is toggled.

8.3.5 Gain Setting

The LM48580 features three internally configured gain settings 18, 24, and 30 dB. The device gain is selected through a single pin (GAIN). The gain settings are shown in 表 1.

表 1. Gain Setting

Gain	Gain Setting
FLOAT	18 dB
GND	24 dB
VDD	30 dB

8.4 Device Functional Modes

8.4.1 Shutdown Function

The LM48580 features a low current shutdown mode. Set $\overline{SD} = \text{GND}$ to disable the amplifier and boost converter and reduce supply current to 0.01 μA .

9 Application and Implementation

注

Information in the following applications sections is not part of the TI component specification, and TI does not warrant its accuracy or completeness. TI's customers are responsible for determining suitability of components for their purposes. Customers should validate and test their design implementation to confirm system functionality.

9.1 Application Information

9.2 Typical Application

The LM48580 is compatible with single-ended sources. When configured for single-ended inputs, input capacitors must be used to block and DC component at the input of the device. 图 15 shows the typical single-ended applications circuit.

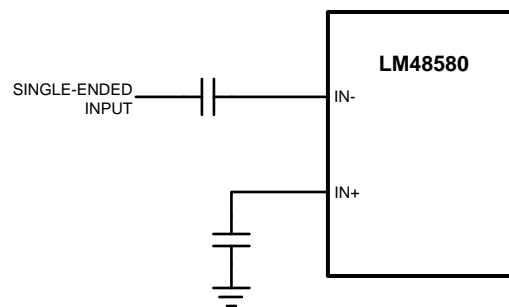

Copyright © 2018, Texas Instruments Incorporated

图 15. Single-Ended Configuration

9.2.1 Design Requirements

9.2.1.1 Proper Selection of External Components

9.2.1.1.1 Boost Converter Capacitor Selection

The LM48580 boost converter requires three external capacitors for proper operation: a 1 μF supply bypass capacitor, and 1 μF + 100 pF output reservoir capacitors. Place the supply bypass capacitor as close to V_{DD} as possible. Place the reservoir capacitors as close to V_{BST} and V_{AMP} as possible. Low ESR surface-mount multi-layer ceramic capacitors with X7R or X5R temperature characteristics are recommended. Select output capacitors with voltage rating of 25 V or higher. Tantalum, OS-CON and aluminum electrolytic capacitors are not recommended. See 表 2 for suggested capacitor manufacturers.

Typical Application (接下页)

9.2.2 Detailed Design Procedure

9.2.2.1 Boost Converter Output Capacitor Selection

9.2.2.1.1 Inductor Selection

The LM48580 boost converter is designed for use with a 4.7 μH inductor. 表 2 lists various inductors and their manufacturers. Choose an inductor with a saturation current rating greater than the maximum operating peak current of the LM48580 ($> 1 \text{ A}$). This ensures that the inductor does not saturate, preventing excess efficiency loss, over heating and possible damage to the inductor. Additionally, choose an inductor with the lowest possible DCR (series resistance) to further minimize efficiency losses.

表 2. Recommended Inductors⁽¹⁾

MANUFACTURER	PART#	INDUCTANCE/ISAT
Taiyo Yuden	BRL3225T4R7M	4.7 $\mu\text{H}/1.1 \text{ A}$
Coilcraft	LP3015	4.7 $\mu\text{H}/1.1 \text{ A}$

(1) See [开发支持](#)

9.2.2.1.2 Diode Selection

Use a Schottkey diode as shown in the *Functional Block Diagram*. A 20 V diode such as the NSR0520V2T1G from On Semiconductor is recommended. The NSR0520V2T1G is designed to handle a maximum average current of 500 mA.

9.2.2.2 Application Curves

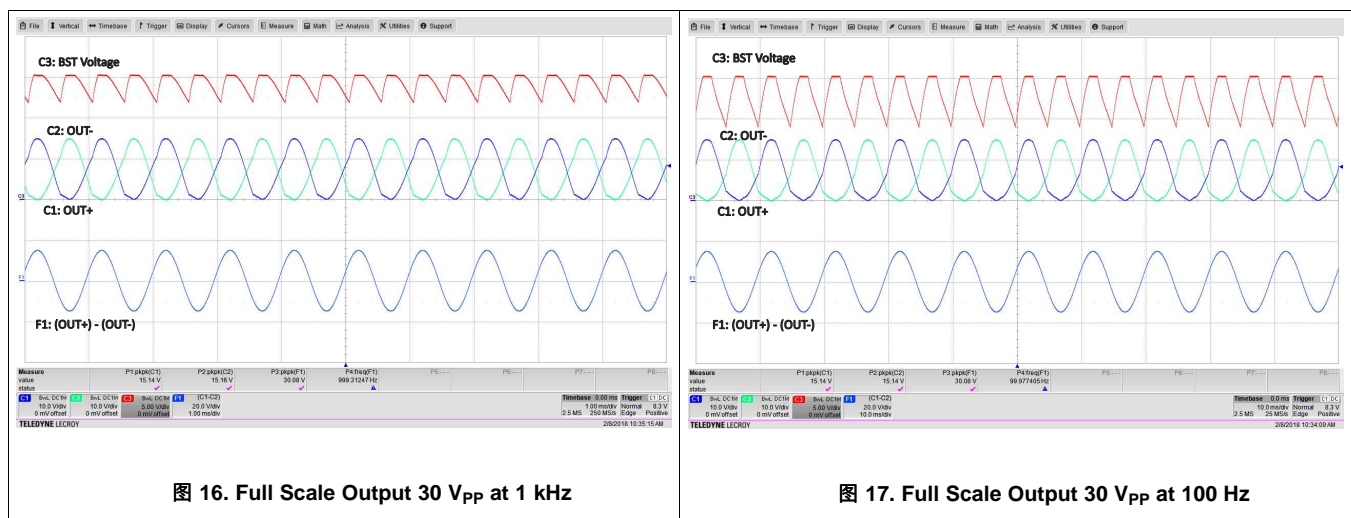

10 Power Supply Recommendations

The LM48580 device is designed to operate with a power supply between 2.5 V and 5.5 V. Proper power supply bypassing is critical for low noise performance and high PSRR. Place the supply bypass capacitors as close to the device as possible. Place a 1- μF ceramic capacitor from VDD to GND. Additional bulk capacitance may be added as required.

11 Layout

11.1 Layout Guidelines

- Minimize trace impedance of the power, ground and all output traces for optimum performance.
- Voltage loss due to trace resistance between the LM48580 and the load results in decreased output power and efficiency.
- Trace resistance between the power supply and ground has the same effect as a poorly regulated supply, increased ripple and reduced peak output power.
- Use wide traces for power supply inputs and amplifier outputs to minimize losses due to trace resistance, as well as route heat away from the device.
- Proper grounding improves audio performance, minimizes crosstalk between channels and prevents switching noise from interfering with the audio signal.
- Use of power and ground planes is recommended.

Place all digital components and route digital signal traces as far as possible from analog components and traces. Do not run digital and analog traces in parallel on the same PCB layer. If digital and analog signal lines must cross either over or under each other, ensure that they cross in a perpendicular fashion.

11.2 Layout Example



图 18. Example Layout

12 器件和文档支持

12.1 器件支持

12.1.1 开发支持

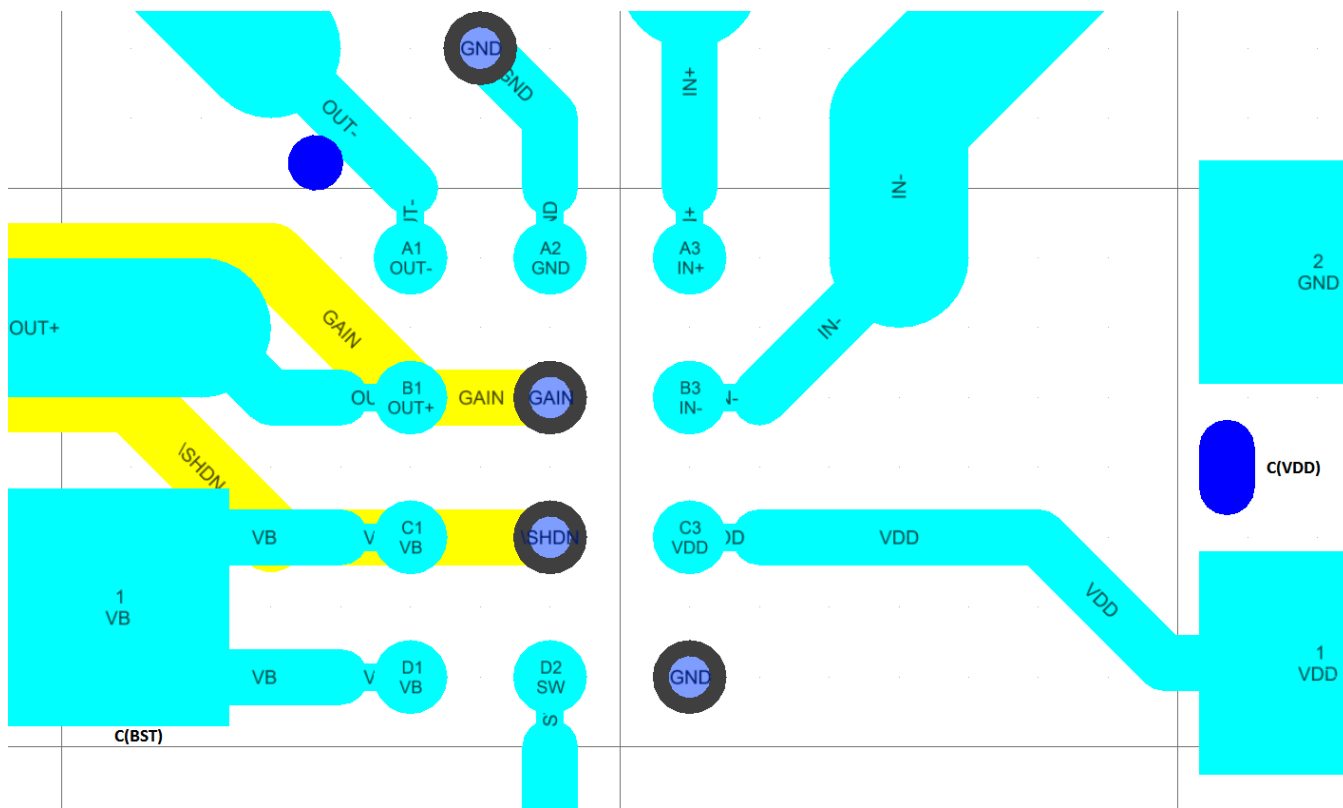
12.1.1.1 第三方产品免责声明

TI 发布的与第三方产品或服务有关的信息，不能构成与此类产品或服务或保修的适用性有关的认可，不能构成此类产品或服务单独或与任何 TI 产品或服务一起的表示或认可。

12.2 接收文档更新通知

要接收文档更新通知，请导航至 TI.com 上的器件产品文件夹。请单击右上角的提醒我 进行注册，即可每周接收产品信息更改摘要。有关更改的详细信息，请查看任何已修订文档中包含的修订历史记录。

12.3 社区资源

下列链接提供到 TI 社区资源的连接。链接的内容由各个分销商“按照原样”提供。这些内容并不构成 TI 技术规范，并且不一定反映 TI 的观点；请参阅 TI 的《使用条款》。

TI E2E™ 在线社区 *TI 的工程师对工程师 (E2E) 社区*。此社区的创建目的在于促进工程师之间的协作。在 e2e.ti.com 中，您可以咨询问题、分享知识、拓展思路并与同行工程师一道帮助解决问题。

设计支持 *TI 参考设计支持* 可帮助您快速查找有帮助的 E2E 论坛、设计支持工具以及技术支持的联系信息。

12.4 商标

Boomer, Powerwise, E2E are trademarks of Texas Instruments.
All other trademarks are the property of their respective owners.

12.5 静电放电警告



ESD 可能会损坏该集成电路。德州仪器 (TI) 建议通过适当的预防措施处理所有集成电路。如果不遵守正确的处理措施和安装程序，可能会损坏集成电路。

ESD 的损坏小至导致微小的性能降级，大至整个器件故障。精密的集成电路可能更容易受到损坏，这是因为非常细微的参数更改都可能会导致器件与其发布的规格不相符。

12.6 Glossary

SLYZ022 — *TI Glossary*.

This glossary lists and explains terms, acronyms, and definitions.

13 机械、封装和可订购信息

以下页面包含机械、封装和可订购信息。这些信息是指定器件的最新可用数据。数据如有变更，恕不另行通知和修订此文档。如欲获取此数据表的浏览器版本，请参阅左侧的导航。

PACKAGING INFORMATION

Orderable Device	Status (1)	Package Type	Package Drawing	Pins	Package Qty	Eco Plan (2)	Lead finish/ Ball material (6)	MSL Peak Temp (3)	Op Temp (°C)	Device Marking (4/5)	Samples
LM48580TL/NOPB	ACTIVE	DSBGA	YZR	12	250	RoHS & Green	SNAGCU	Level-1-260C-UNLIM	-40 to 85	GM3	Samples
LM48580TLX/NOPB	ACTIVE	DSBGA	YZR	12	3000	RoHS & Green	SNAGCU	Level-1-260C-UNLIM	-40 to 85	GM3	Samples

(1) The marketing status values are defined as follows:

ACTIVE: Product device recommended for new designs.

LIFEBUY: TI has announced that the device will be discontinued, and a lifetime-buy period is in effect.

NRND: Not recommended for new designs. Device is in production to support existing customers, but TI does not recommend using this part in a new design.

PREVIEW: Device has been announced but is not in production. Samples may or may not be available.

OBSOLETE: TI has discontinued the production of the device.

(2) **RoHS:** TI defines "RoHS" to mean semiconductor products that are compliant with the current EU RoHS requirements for all 10 RoHS substances, including the requirement that RoHS substance do not exceed 0.1% by weight in homogeneous materials. Where designed to be soldered at high temperatures, "RoHS" products are suitable for use in specified lead-free processes. TI may reference these types of products as "Pb-Free".

RoHS Exempt: TI defines "RoHS Exempt" to mean products that contain lead but are compliant with EU RoHS pursuant to a specific EU RoHS exemption.

Green: TI defines "Green" to mean the content of Chlorine (Cl) and Bromine (Br) based flame retardants meet JS709B low halogen requirements of <=1000ppm threshold. Antimony trioxide based flame retardants must also meet the <=1000ppm threshold requirement.

(3) MSL, Peak Temp. - The Moisture Sensitivity Level rating according to the JEDEC industry standard classifications, and peak solder temperature.

(4) There may be additional marking, which relates to the logo, the lot trace code information, or the environmental category on the device.

(5) Multiple Device Markings will be inside parentheses. Only one Device Marking contained in parentheses and separated by a "~" will appear on a device. If a line is indented then it is a continuation of the previous line and the two combined represent the entire Device Marking for that device.

(6) Lead finish/Ball material - Orderable Devices may have multiple material finish options. Finish options are separated by a vertical ruled line. Lead finish/Ball material values may wrap to two lines if the finish value exceeds the maximum column width.

Important Information and Disclaimer:The information provided on this page represents TI's knowledge and belief as of the date that it is provided. TI bases its knowledge and belief on information provided by third parties, and makes no representation or warranty as to the accuracy of such information. Efforts are underway to better integrate information from third parties. TI has taken and continues to take reasonable steps to provide representative and accurate information but may not have conducted destructive testing or chemical analysis on incoming materials and chemicals. TI and TI suppliers consider certain information to be proprietary, and thus CAS numbers and other limited information may not be available for release.

In no event shall TI's liability arising out of such information exceed the total purchase price of the TI part(s) at issue in this document sold by TI to Customer on an annual basis.

TAPE AND REEL INFORMATION

QUADRANT ASSIGNMENTS FOR PIN 1 ORIENTATION IN TAPE

*All dimensions are nominal

Device	Package Type	Package Drawing	Pins	SPQ	Reel Diameter (mm)	Reel Width W1 (mm)	A0 (mm)	B0 (mm)	K0 (mm)	P1 (mm)	W (mm)	Pin1 Quadrant
LM48580TL/NOPB	DSBGA	YZR	12	250	178.0	8.4	1.68	2.13	0.76	4.0	8.0	Q1
LM48580TLX/NOPB	DSBGA	YZR	12	3000	178.0	8.4	1.68	2.13	0.76	4.0	8.0	Q1

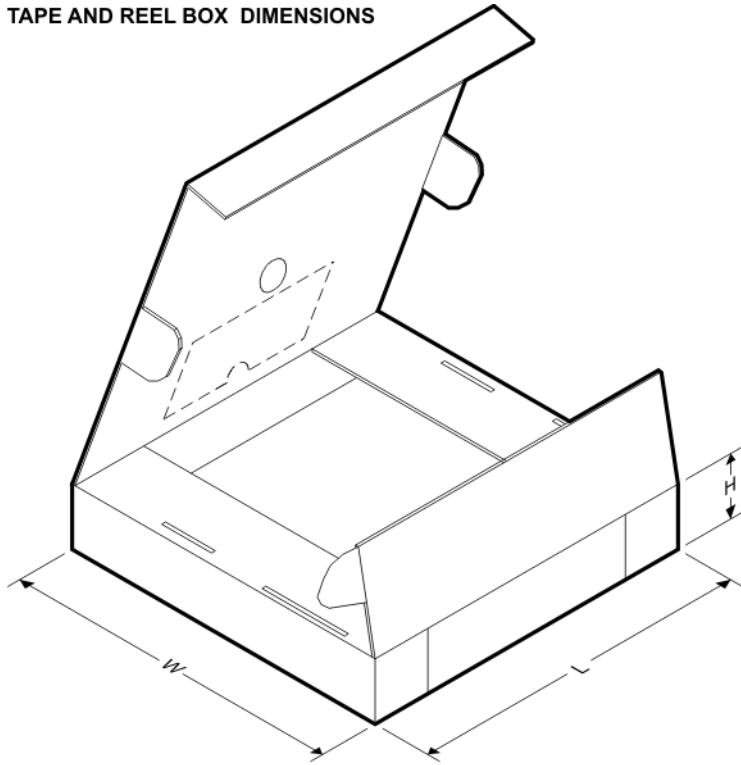
TAPE AND REEL BOX DIMENSIONS

*All dimensions are nominal

Device	Package Type	Package Drawing	Pins	SPQ	Length (mm)	Width (mm)	Height (mm)
LM48580TL/NOPB	DSBGA	YZR	12	250	208.0	191.0	35.0
LM48580TLX/NOPB	DSBGA	YZR	12	3000	208.0	191.0	35.0

重要声明和免责声明

TI“按原样”提供技术和可靠性数据（包括数据表）、设计资源（包括参考设计）、应用或其他设计建议、网络工具、安全信息和其他资源，不保证没有瑕疵且不做任何明示或暗示的担保，包括但不限于对适销性、某特定用途方面的适用性或不侵犯任何第三方知识产权的暗示担保。

这些资源可供使用 TI 产品进行设计的熟练开发人员使用。您将自行承担以下全部责任：(1) 针对您的应用选择合适的 TI 产品，(2) 设计、验证并测试您的应用，(3) 确保您的应用满足相应标准以及任何其他功能安全、信息安全、监管或其他要求。

这些资源如有变更，恕不另行通知。TI 授权您仅可将这些资源用于研发本资源所述的 TI 产品的应用。严禁对这些资源进行其他复制或展示。您无权使用任何其他 TI 知识产权或任何第三方知识产权。您应全额赔偿因在这些资源的使用中对 TI 及其代表造成的任何索赔、损害、成本、损失和债务，TI 对此概不负责。

TI 提供的产品受 [TI 的销售条款](#) 或 [ti.com](#) 上其他适用条款/TI 产品随附的其他适用条款的约束。TI 提供这些资源并不会扩展或以其他方式更改 TI 针对 TI 产品发布的适用的担保或担保免责声明。

TI 反对并拒绝您可能提出的任何其他或不同的条款。

邮寄地址：Texas Instruments, Post Office Box 655303, Dallas, Texas 75265
Copyright © 2021，德州仪器 (TI) 公司