

Dual output AMOLED Display Power Supply

Check for Samples: [TPS65138](#), [TPS65138A](#)

FEATURES

- 2.9V to 4.5V Input Voltage Range
- 0.8% Output Voltage Accuracy V_{POS}
- Excellent Line Transient Regulation
- 300mA Output Current
- Fixed 4.62V Positive Output Voltage
- Digitally Programmable V_{NEG}
 - TPS65138: -2.2V to -6.2V
 - TPS65138A: -2.2V to -5.2V
- -4.9V Default Value for V_{NEG}
- Short Circuit Protection
- Thermal Hhutdown
- 3-mm × 3-mm QFN Package

APPLICATIONS

- Active Matrix OLED

DESCRIPTION

The TPS65138 is designed to drive AMOLED displays (Active Matrix Organic Light Emitting Diode) requiring positive and negative supply rails. The device integrates boost converter and inverting buck boost converter designed suitable for battery operated products. The digital control pin (CTRL) allows programming the negative output voltage in digital steps. The TPS65138 uses a novel technology enabling excellent line and load regulation. This is required to avoid disturbance of the AMOLED display by the input voltage disturbances occurring during transmit periods in mobile phones.

TYPICAL APPLICATION SCHEMATIC

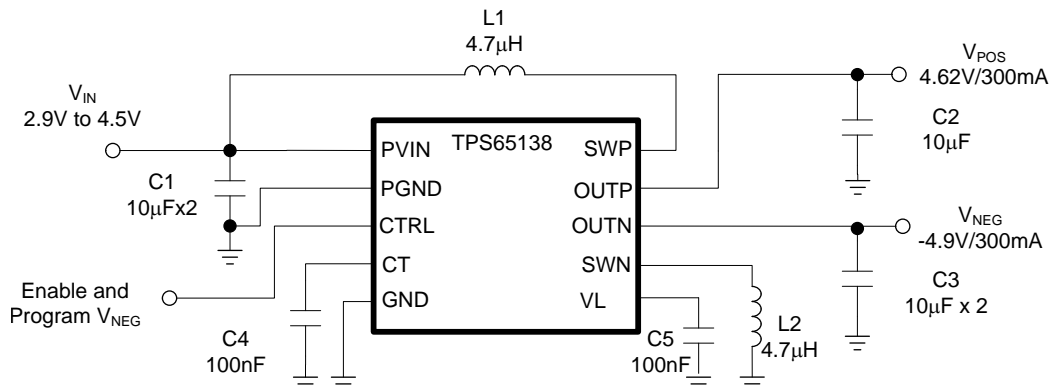

Please be aware that an important notice concerning availability, standard warranty, and use in critical applications of Texas Instruments semiconductor products and disclaimers thereto appears at the end of this data sheet.



These devices have limited built-in ESD protection. The leads should be shorted together or the device placed in conductive foam during storage or handling to prevent electrostatic damage to the MOS gates.

ORDERING INFORMATION⁽¹⁾

T _A	V _{NEG} PROGRAMMING RANGE	PACKAGE ⁽²⁾	ORDERABLE PART NUMBER	TOP-SIDE MARKING
-40°C to +85°	-2.2V ~ -6.2V	10-Pin 3x3 QFN	TPS65138DRCR	PUCC
	-2.2V ~ -5.2V		TPS65138ADRCR	PXJI

- (1) For the most current package and ordering information, see the Package Option Addendum at the end of this document, or see the TI website at www.ti.com.
 (2) Package drawings, thermal data, and symbolization are available at www.ti.com/packaging.

ABSOLUTE MAXIMUM RATINGS⁽¹⁾

over operating free-air temperature range (unless otherwise noted)

		VALUE		UNIT
		MIN	MAX	
Voltage range ⁽²⁾	PVIN, SWP, OUTP, CTRL, VL		5.5	V
	OUTN		-6.5	
	SWN	-6.5	4.8	
	CT		3.6	
ESD rating	HBM		±2	kV
	MM		±200	V
	CDM		±500	V
Operating junction temperature range, T _J		-40	50	°C
Operating ambient temperature range, T _A		-40	85	°C
Storage temperature range, T _{stg}		-65	150	°C

- (1) Stresses beyond those listed under “absolute maximum ratings” may cause permanent damage to the device. These are stress ratings only, and functional operation of the device at these or any other conditions beyond those indicated under “recommended operating conditions” is not implied. Exposure to absolute-maximum-rated conditions for extended periods may affect device reliability.
 (2) All voltage values are with respect to GND pin

THERMAL INFORMATION⁽¹⁾

THERMAL METRIC		DRC	UNITS
		10-PINS	
θ _{JA}	Junction-to-ambient thermal resistance	54.7	°C/W
θ _{JB}	Junction-to-board thermal resistance	16.9	
ψ _{JT}	Junction-to-top characterization parameter	4.2	
ψ _{JB}	Junction-to-board characterization parameter	19.5	

- (1) For more information about traditional and new thermal metrics, see the IC Package Thermal Metrics application report, [SPRA953](http://www.ti.com/lit/zip/Spra953)

RECOMMENDED OPERATING CONDITIONS

		MIN	NOM	MAX	UNIT
V_{IN}	Input voltage range	2.9	3.7	4.5	V
T_A	Operating ambient temperature	-40	25	95	°C
T_J	Operating junction temperature	-40	85	125	°C

ELECTRICAL CHARACTERISTICS

$V_{IN} = 3.7V$, $CTRL = V_{IN}$, $V_{POS} = 4.62V$, $V_{NEG} = -4.9V$, $T_A = -40^{\circ}C$ to $95^{\circ}C$, typical values are at $T_A = 25^{\circ}C$
(unless otherwise noted)

PARAMETER		TEST CONDITIONS	MIN	TYP	MAX	UNIT
Supply Current and Thermal Protection						
V_{IN}	Input voltage range		2.9		4.5	V
I_Q	Operating quiescent current into V_{IN}	V_{POS} and V_{NEG} have no load ⁽¹⁾		13		mA
I_{SD}	Shutdown current into V_{IN}	$CTRL = GND$		0.1		μA
V_L	Output of internal regulator			5		V
V_{UVLO}	Under-voltage lockout threshold	V_{IN} falling			2.1	V
		V_{IN} rising			2.4	V
	Thermal shutdown			145		°C
	Thermal shutdown hysteresis			10		°C
Output V_{POS}						
V_{POS}	Positive output voltage			4.62		V
	Positive output voltage regulation	$T_A = -40^{\circ}C$ to $85^{\circ}C$	-0.8%		0.8%	
$r_{DS(on)}$	SWP MOSFET on-resistance	$I_{SWP} = 200mA$		200		m Ω
	SWN MOSFET rectifier on-resistance	$I_{SWP} = 200mA$		250		m Ω
f_{SWP}	SWP Switching frequency	$I_{POS} = 0mA$		1.6		MHz
I_{SWP}	SWP switch current limit	Inductor valley current	0.8	1		A
$V_{P(SCP)}$	Short circuit threshold in operation	V_{POS} falling		3.7		V
$t_{P(SCP)}$	Short circuit detection time in operation			8		ms
	Short circuit detection time in operation			3		ms
I_{LKG}	Leakage current into V_{POS}	$CTRL = GND$		2	5	μA
	Line regulation	$I_{POS} = 400mA$		0		%/V
	Load regulation			0		%/A

(1) With Inductor DFE252012C 4.7 μH from TOKO

ELECTRICAL CHARACTERISTICS (continued)

$V_{IN} = 3.7V$, CTRL = V_{IN} , $V_{POS} = 4.62V$, $V_{NEG} = -4.9V$, $T_A = -40^{\circ}C$ to $95^{\circ}C$, typical values are at $T_A = 25^{\circ}C$ (unless otherwise noted)

PARAMETER		TEST CONDITIONS	MIN	TYP	MAX	UNIT
Output V_{NEG}						
V_{NEG}	Negative output voltage default			-0.94		V
	Negative output voltage range	TPS65138	-2.2		-6.2	V
		TPS65138A	-2.2		-5.2	V
	Negative output voltage regulation	TPS65138, $-6.2 \leq V_{NEG} \leq -4.2$	-1%		1%	
		TPS65138A, $-5.2 \leq V_{NEG} \leq -4.2$	-1%		1%	
	$-4.2 \leq V_{NEG} \leq -2.2$	-1.5%		1.5%		
$r_{DS(on)}$	SWN MOSFET on-resistance	$I_{SWN} = 200$ mA		200		m Ω
	SWN MOSFET rectifier on-resistance	$I_{SWN} = 200$ mA		300		m Ω
f_{SWN}	SWN Switching frequency	$I_{NEG} = 100$ mA		1.6		MHz
	SWN switch current limit	$V_{IN} = 2.9$ V	1.8	2.2		A
$V_{N(SCP)}$	Short circuit threshold in operation			-1		V
	Short circuit threshold in start-up		0.15	0.28	0.42	V
$t_{N(SCP)}$	Short circuit detection time in start-up			8		V
	Short circuit detection time in operation			3		ms
I_{LKG}	Leakage current out of V_{NEG}	CTRL = GND		2	5	μ A
$R_{N(PD)}$	V_{NEG} Pull down resistor before start up	$I_{NEG} = 1$ mA		270		Ω
	Line regulation			0		%/V
	Load regulation			0		%/A
CTRL Interface						
V_H	Logic high-level voltage		1.2			V
V_L	Logic low-level voltage				0.4	V
R	Pull down resistor		150	400	860	K Ω
t_{INIT}	Initialization time			300	400	μ s
t_{OFF}	Shutdown time period		30		80	μ s
t_{HIGH}	Pulse high level time period		2	10	25	μ s
t_{LOW}	Pulse low level time period		2	10	25	μ s
t_{STORE}	Data storage and accept time period		30		80	μ s
R_T	C_T pin output impedance		150	325	500	k Ω

PINOUT

(TOP VIEW)

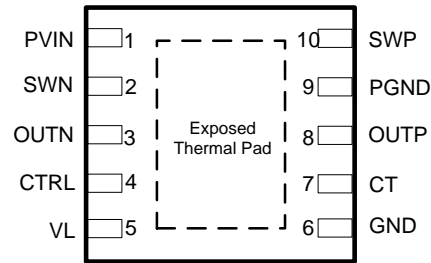

PIN FUNCTIONS

NUMBER	NAME	TYPE ⁽¹⁾	DESCRIPTION
1	PVIN	I	Input supply for the negative buck boost converter generating V_{NEG}
2,	SWN	I	Switch pin of the negative buck boost converter
3	OUTN	O	Output of the negative buck boost converter
4	CTRL	O	Combined enable and V_{NEG} program pin.
5	VL	O	Output of internal regulator
6	GND	G	Analog ground
7	CT	O	Sets the settling time for the voltage on V_{NEG} when programmed to a new value.
8	OUTP	O	Output of the boost converter
9	PGND	G	Power ground of the boost converter
10	SWP	I	Switch pin of the boost converter
	Exposed thermal pad	G	Connect this pad to analog GND.

(1) G = Ground, I = Input, O = Output

FUNCTIONAL BLOCK DIAGRAM

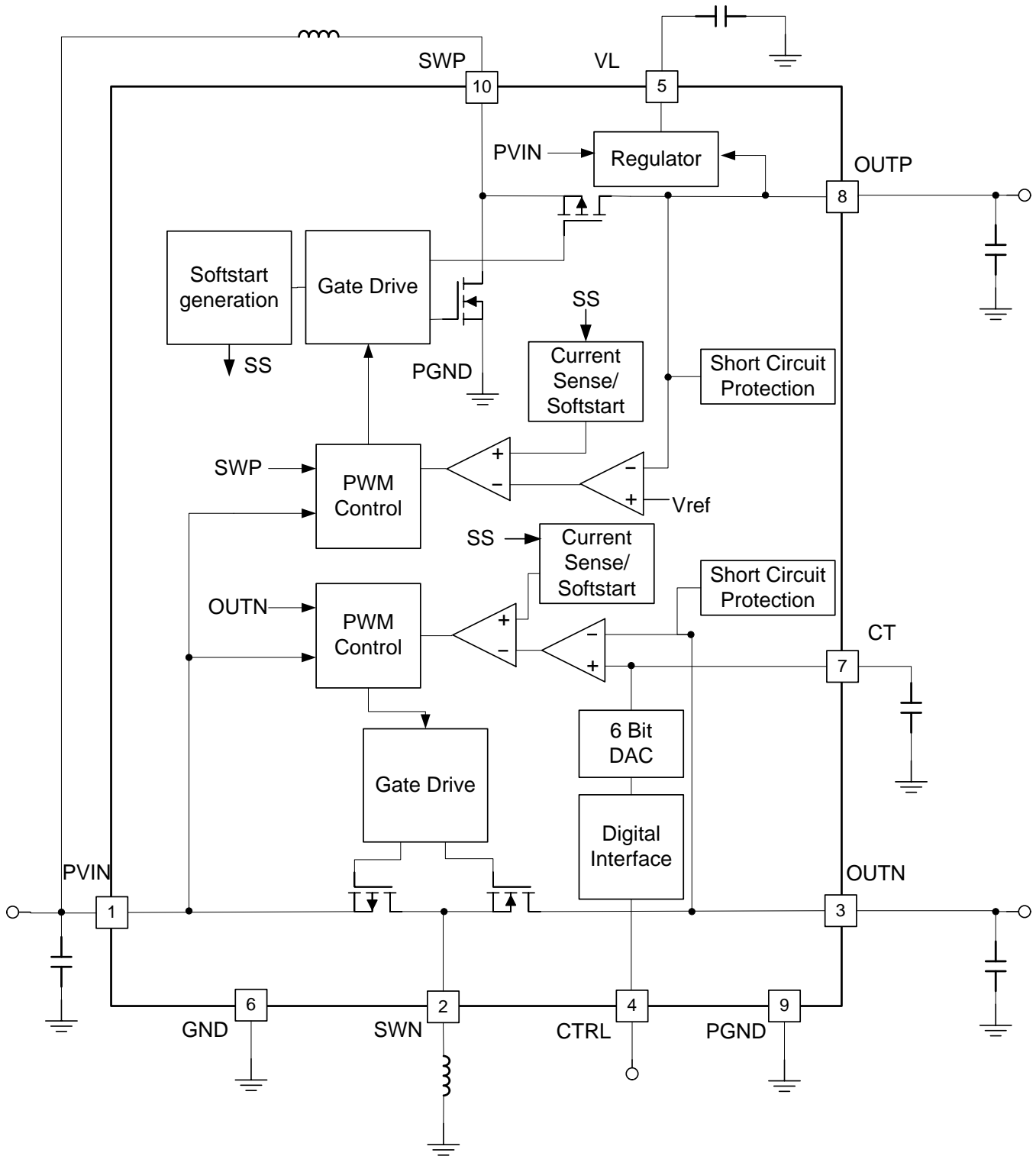

Table 1. TABLE OF GRAPHS

TITLE	TEST CONDITIONS	FIGURE
Efficiency versus Output current (Output current is from V_{POS} to V_{NEG} .)	V_{POS} 4.62 V, V_{NEG} -4.9 V	Figure 1
Start-up		Figure 2
Switch pins and output waveforms	I_{OUT} 100 mA, Boost and BuckBoost	Figure 3
	I_{OUT} 300 mA, Boost and BuckBoost	Figure 4
	I_{OUT} 300 mA, Boost	Figure 5
	I_{OUT} 300 mA, BuckBoost	Figure 6

TYPICAL CHARACTERISTICS

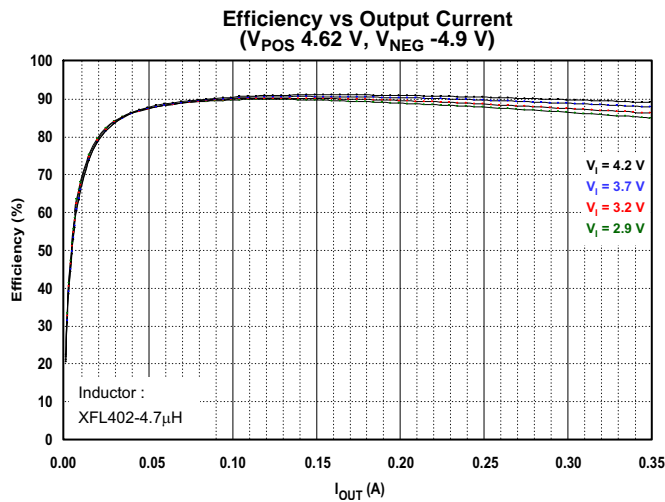

Figure 1.

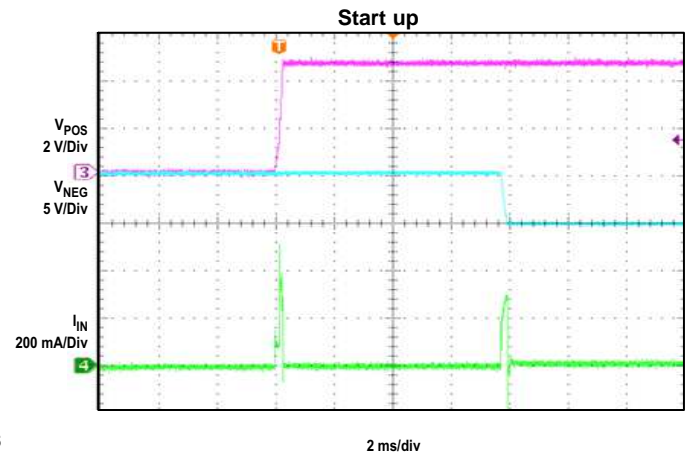

Figure 2.

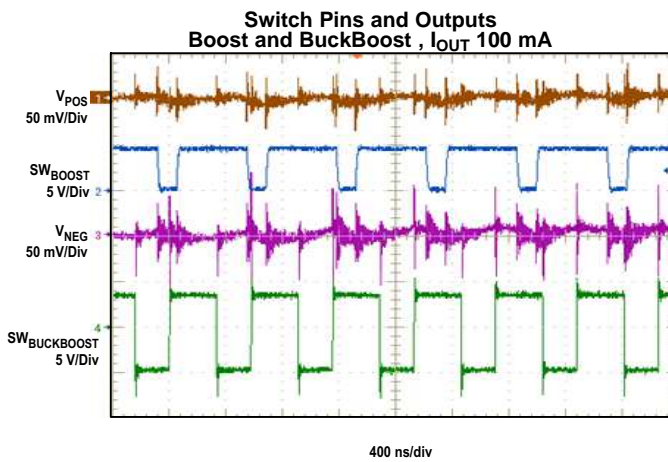

Figure 3.

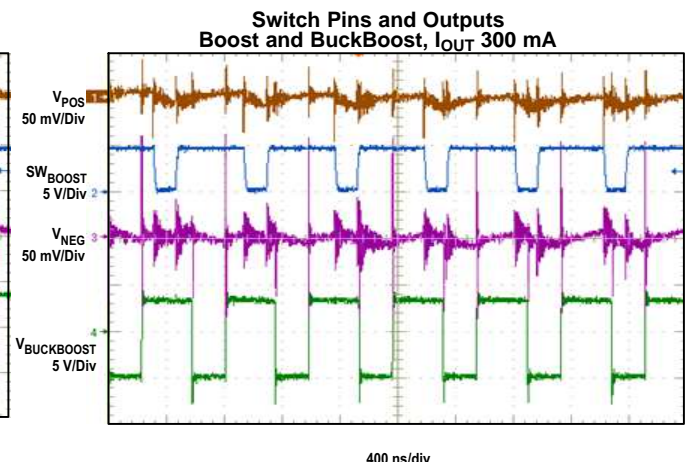
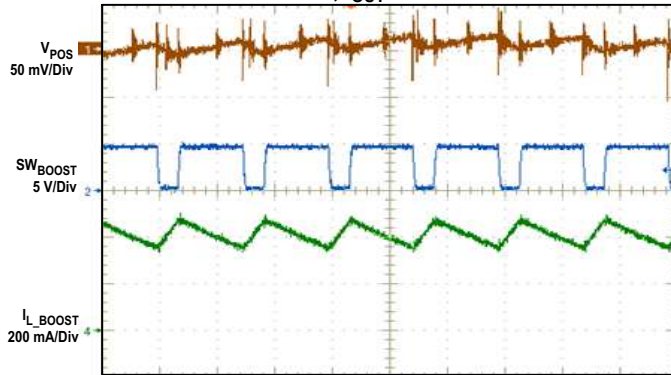

Figure 4.

TYPICAL CHARACTERISTICS (continued)

**Switch Pins and Outputs
Boost, I_{OUT} 300 mA**



400 ns/div
Figure 5.

**Switch Pins and Outputs
BuckBoost, I_{OUT} 300 mA**

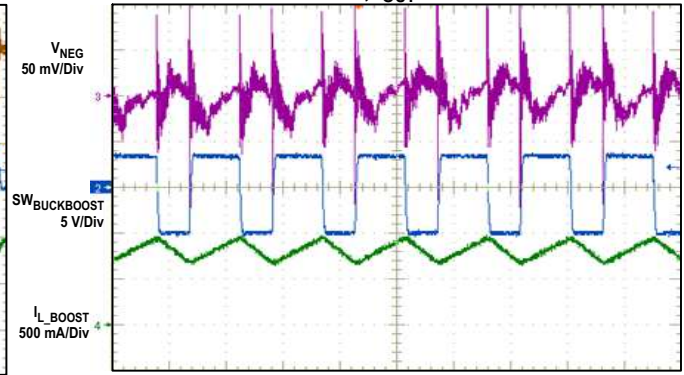

400 ns/div
Figure 6.

APPLICATION INFORMATION

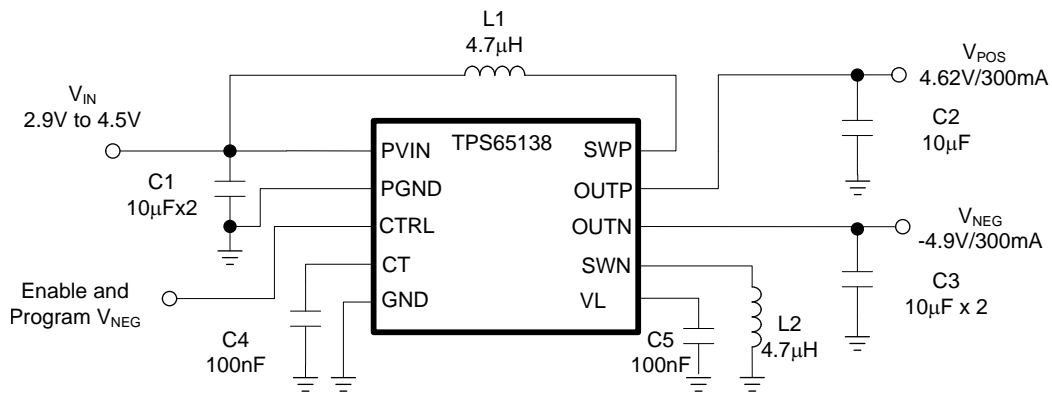

Figure 7. Application for Typical Characteristics

Table 2. Bill of Materials for Typical Characteristics

	Value	Part Number	Manufacturer
C1	10 µF, X7R	GRM21BR70J106KE76	Murata
C2A, C2B, C3A, C3B	4.7 µF, X7R	GRM21BR71A475KA73	Murata
C4, C5	100 nF, X7R	GRM21BR71E104KA01	Murata
L1, L2	4.7 µH	XFL4020-472M	Coil Craft

DETAIL DESCRIPTION

The TPS65138 consists of a boost converter and an inverting buck boost converter. The positive output is fixed at 4.62V. Negative output is programmable by a digital interface, and TPS65138 has the range of -2.2V to approximately -6.2V and TPS65138A has the range of -2.2V to approximately -5.2V. Both TPS65138 and TPS65138A have -4.9V of the default negative output. The transition time of the negative output is adjustable by the CT pin capacitor.

SOFT START and START-UP SEQUENCE

The device has soft start to limit inrush current. When the device is enabled by CTRL pin going HIGH, the boost converter starts with reduced switch current limit. 8 ms after CTRL HIGH, Buck boost converter starts with the default value. V_{NEG} default is -4.9 V. The typical start-up sequence is shown in [Figure 8](#).

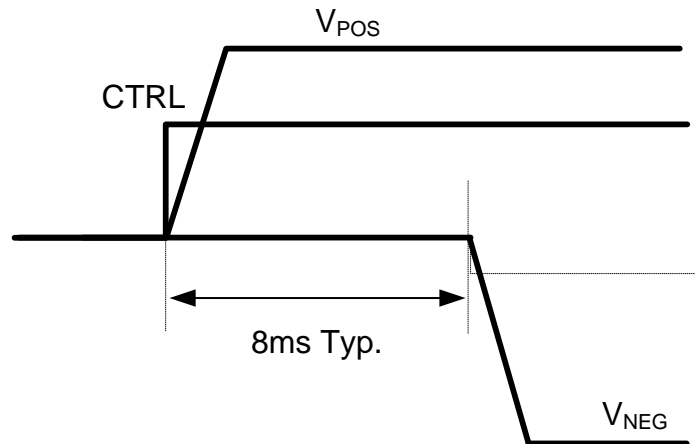

Figure 8. Start-up Sequence

SHORT CIRCUIT PROTECTION

The device is protected against short circuits of the outputs to ground and short circuit of the outputs each other. During normal operation, an error condition is detected if V_{POS} falls below 3.7 V for more than 3 ms or V_{NEG} is above -1 V for more than 3 ms. In either case, the device goes into shutdown and this state is latched. Input and outputs are disconnected. To resume normal operation, V_{IN} has to cycle below UVLO or CTRL has to toggle LOW and HIGH.

During start up, an error condition is detected in the following cases:

- V_{POS} is not in regulation 8ms after CTRL goes HIGH.
- V_{NEG} is higher than threshold level of 8ms after CTRL goes HIGH.
- V_{NEG} is not in regulation 16ms after CTRL goes HIGH.

For these cases, the device goes into shutdown and this state is latched. Input and outputs are disconnected. To resume normal operation, V_{IN} has to cycle below UVLO or CTRL has to toggle LOW and HIGH.

ENABLE (CTRL PIN)

The CTRL pin serves two functions. One is to enable and disable the device the other is the output voltage programming of the device. If the digital interface is not required the CTRL pin can be used as a standard enable pin for the device and the device will come up with its default value on V_{NEG} of -4.9V. When CTRL is pulled high, the device is enabled. The device is shut down with CTRL low.

DIGITAL INTERFACE (CTRL PIN)

The digital interface allows programming the negative output voltage V_{NEG} in digital steps. If the digital output voltage setting is not required then the CTRL pin can also be used as a standard enable pin. The digital output voltage programming of V_{NEG} is implemented by a simple digital interface with the timing shown in [Figure 9](#).

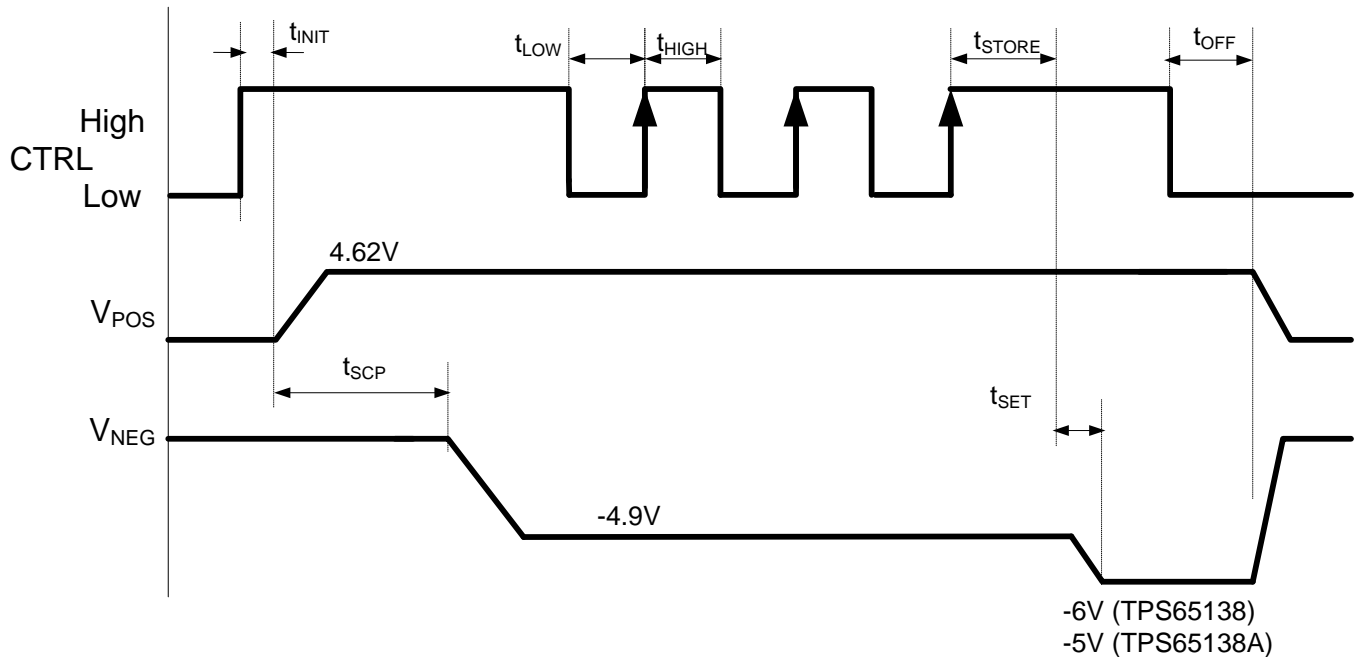

Figure 9. Digital Interface Using CTRL

Once CTRL is pulled high the device will come up with its default voltage of -4.9V. The device has a 6 bit DAC implemented with the corresponding output voltages as given in [Table 3](#) and [Table 4](#). The interface counts now the rising edges applied to CTRL pin once the device is enabled. For the timing table shown in [Table 3](#) and [Table 4](#), V_{NEG} is programmed to -6V in TPS65138 and -5V in TPS65138A, since 3 rising edges are detected. Other output voltages are programmed according to [Table 3](#) and [Table 4](#).

Table 3. TPS65138 Programming Table for V_{NEG}

Bit / rising edges	V_{NEG}	DAC Value	Bit / rising edges	V_{NEG}	DAC Value
0/ no pulse	-4.9V	000000	21	-4.2V	010101
1	-6.2V	000001	22	-4.1V	010110
2	-6.1V	000010	23	-4.0V	010111
3	-6.0V	000011	24	-3.9V	011000
4	-5.9V	000100	25	-3.8V	011001
5	-5.8V	000101	26	-3.7V	011010
6	-5.7V	000110	27	-3.6V	011011
7	-5.6V	000111	28	-3.5V	011100
8	-5.5V	001000	29	-3.4V	011101
9	-5.4V	001001	30	-3.3V	011110
10	-5.3V	001010	31	-3.2V	011111
11	-5.2V	001011	32	-3.1V	100000
12	-5.1V	001100	33	-3.0V	100001
13	-5.0V	001101	34	-2.9V	100010
14	-4.9V	001110	35	-2.8V	100011
15	-4.8V	001111	36	-2.7V	100100
16	-4.7V	010000	37	-2.6V	100101
17	-4.6V	010001	38	-2.5V	100110
18	-4.5V	010010	39	-2.4V	100111
19	-4.4V	010011	40	-2.3V	101000
20	-4.3V	010100	41	-2.2V	101001

Table 4. TPS65138A Programming Table for V_{NEG}

Bit / rising edges	V_{NEG}	DAC Value	Bit / rising edges	V_{NEG}	DAC Value
0/ no pulse	-4.9V	000000	16	-3.7V	010000
1	-5.2V	000001	17	-3.6V	010001
2	-5.1V	000010	18	-3.5V	010010
3	-5.0V	000011	19	-3.4V	010011
4	-4.9V	000100	20	-3.3V	010100
5	-4.8V	000101	21	-3.2V	010101
6	-4.7V	000110	22	-3.1V	010110
7	-4.6V	000111	23	-3.0V	010111
8	-4.5V	001000	24	-2.9V	011000
9	-4.4V	001001	25	-2.8V	011001
10	-4.3V	001010	26	-2.7V	011010
11	-4.2V	001011	27	-2.6V	011011
12	-4.1V	001100	28	-2.5V	011100
13	-4.0V	001101	29	-2.4V	011101
14	-3.9V	001110	30	-2.3V	011110
15	-3.8V	001111	31	-2.2V	011111

SETTING TRANSITION TIME t_{set} for V_{NEG}

The device allows setting the transition time t_{set} using an external capacitor connected to pin CT. The transition time is the time period required to move V_{NEG} from one voltage level to the next programmed voltage level. The capacitor connected to pin CT does not influence on the soft start time t_{ss} of V_{NEG} default value. When the CT pin is left open then the shortest possible transition time is programmed. When connecting a capacitor to the CT pin then the transition time is given by the R-C time constant. This is given by the output impedance of the CT pin typically 325 k Ω and the external capacitance. Within one τ the output voltage of V_{NEG} has reached 70% of its programmed value. An example is given when using 100nF for C_T .

$$\tau \approx t_{set\ 70\%} = 325k\Omega \times C_T = 325k\Omega \times 100nF = 32.5ms \quad (1)$$

The V_{NEG} programmed voltage is almost in nominal value after 3 τ .

PCB LAYOUT DESIGN GUIDELINES

Figure 10 and Figure 11 show the example of PCB layout design.

1. Place the input capacitor on PVIN and the output capacitor on OUTN as close as possible to device. Use short and wide traces to connect the input capacitor on PVIN and the output capacitor on OUTN.
2. Place the output capacitor on OUTP as close as possible to device. Use short and wide traces to connect the output capacitor on OUTP.
3. Connect the ground of CT capacitor with GND, pin 6, directly.
4. Connect input ground and output ground on the same board layer, not through via hole.

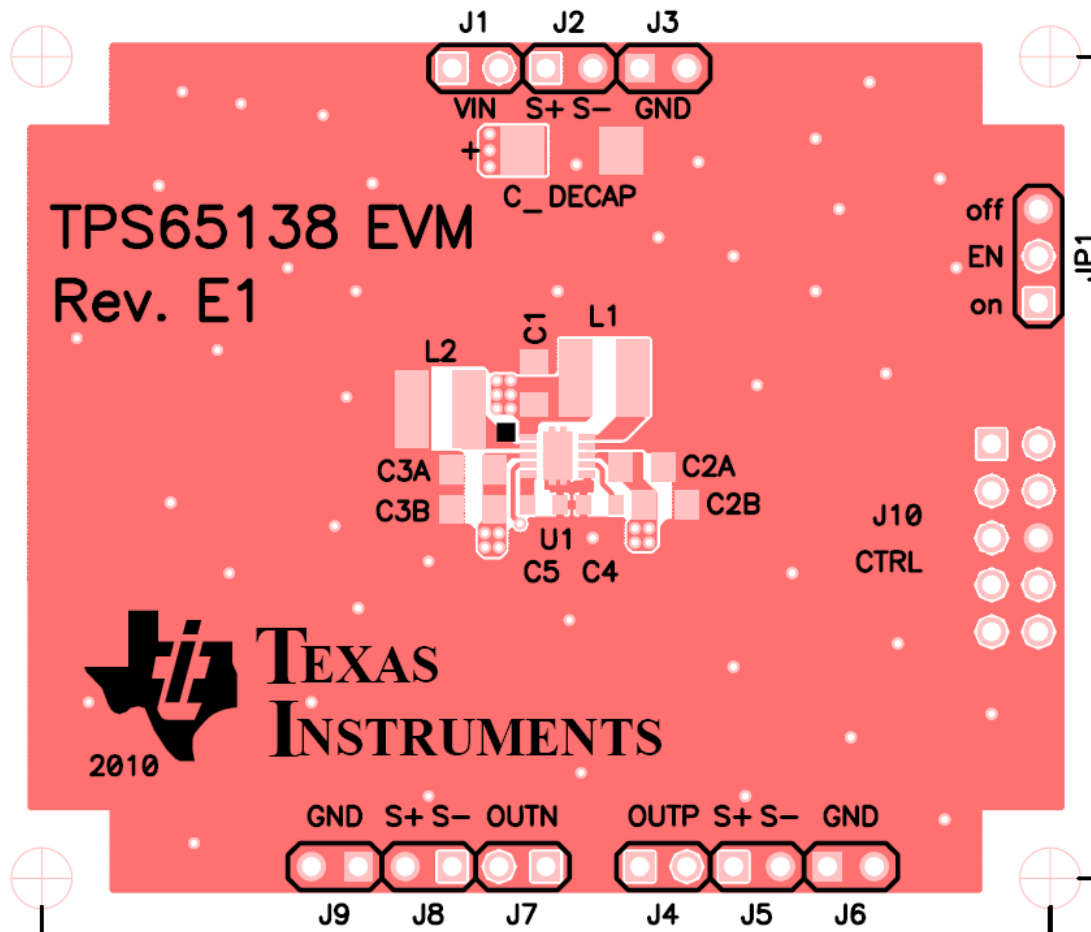

Figure 10. Example of Board Layout. Top Layer

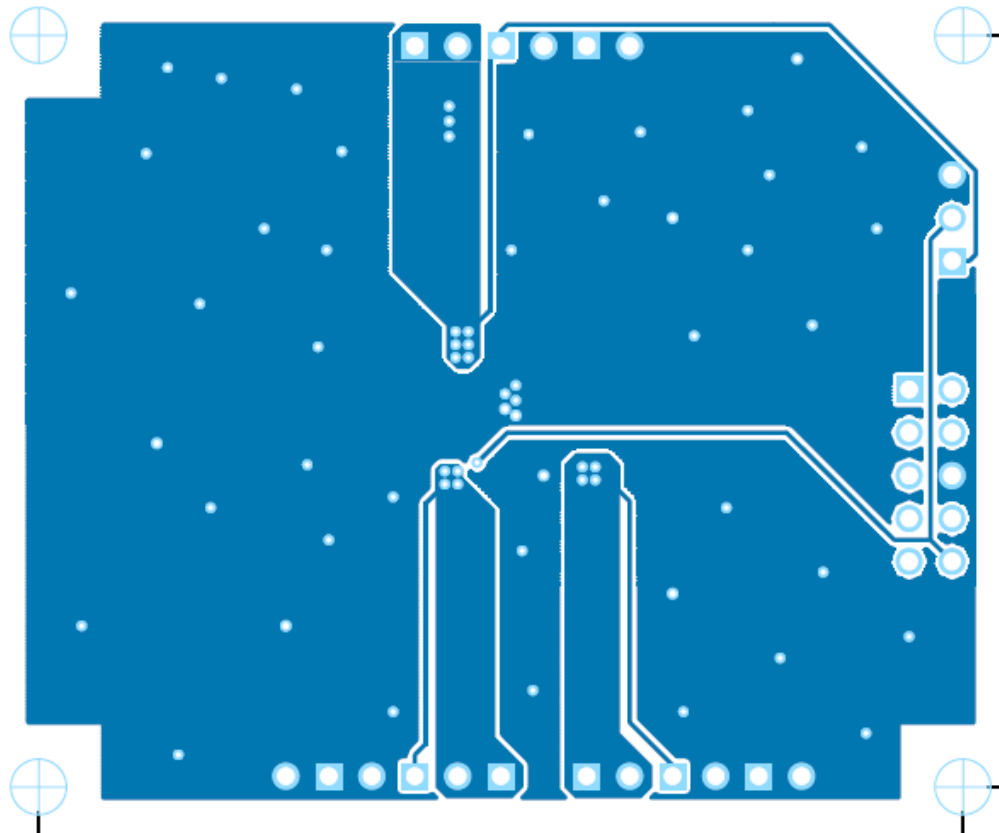

Figure 11. Example of Board Layout. Bottom Layer

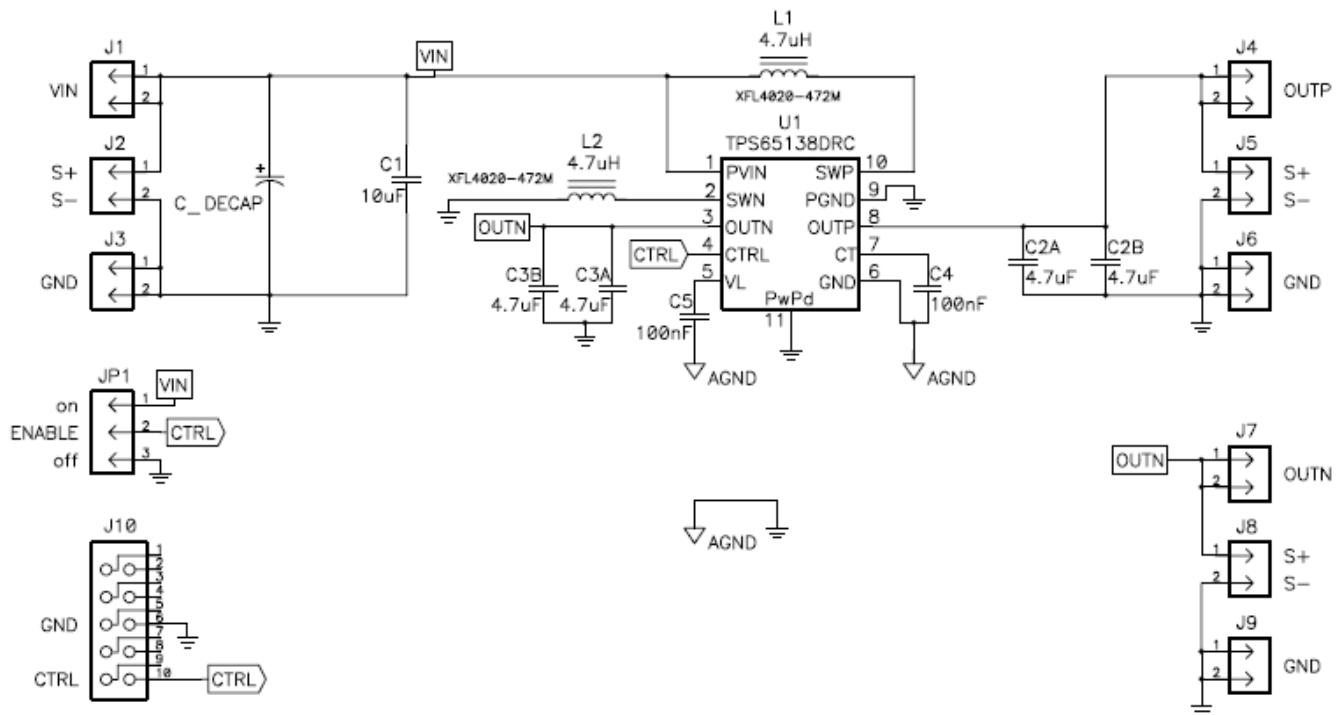

Figure 12. Schematic of Board Layout Example

REVISION HISTORY

Changes from Original (April 2011) to Revision A	Page
--	------

- Changed the TYPICAL CHARACTERISTICS. Deleted Figure 2, Figure 3, Figure 9 through Figure 12 7
-

Changes from Revision A (May 2011) to Revision B	Page
--	------

- Added Feature TPS65138A: -2.2V to -5.2V 1
 - Added V_{NEG} Negative output voltage range for TPS65138A, -2.2V to -5.2V 4
 - Added V_{NEG} programming range of TPS65138A, -2.2V to -5.2V to the Detailed Description 9
 - Changed [Figure 9](#) 10
-

Changes from Revision B (April 2012) to Revision C	Page
--	------

- Changed the device From: Product Preview To: Production 1
-

PACKAGING INFORMATION

Orderable Device	Status (1)	Package Type	Package Drawing	Pins	Package Qty	Eco Plan (2)	Lead finish/ Ball material (6)	MSL Peak Temp (3)	Op Temp (°C)	Device Marking (4/5)	Samples
TPS65138ADRCR	ACTIVE	VSON	DRC	10	3000	RoHS & Green	NIPDAU	Level-2-260C-1 YEAR	-40 to 85	PXJI	Samples
TPS65138DRRCR	ACTIVE	VSON	DRC	10	3000	RoHS & Green	NIPDAU	Level-2-260C-1 YEAR	-40 to 85	PUCG	Samples

(1) The marketing status values are defined as follows:

ACTIVE: Product device recommended for new designs.

LIFEBUY: TI has announced that the device will be discontinued, and a lifetime-buy period is in effect.

NRND: Not recommended for new designs. Device is in production to support existing customers, but TI does not recommend using this part in a new design.

PREVIEW: Device has been announced but is not in production. Samples may or may not be available.

OBSOLETE: TI has discontinued the production of the device.

(2) **RoHS:** TI defines "RoHS" to mean semiconductor products that are compliant with the current EU RoHS requirements for all 10 RoHS substances, including the requirement that RoHS substance do not exceed 0.1% by weight in homogeneous materials. Where designed to be soldered at high temperatures, "RoHS" products are suitable for use in specified lead-free processes. TI may reference these types of products as "Pb-Free".

RoHS Exempt: TI defines "RoHS Exempt" to mean products that contain lead but are compliant with EU RoHS pursuant to a specific EU RoHS exemption.

Green: TI defines "Green" to mean the content of Chlorine (Cl) and Bromine (Br) based flame retardants meet JS709B low halogen requirements of <=1000ppm threshold. Antimony trioxide based flame retardants must also meet the <=1000ppm threshold requirement.

(3) MSL, Peak Temp. - The Moisture Sensitivity Level rating according to the JEDEC industry standard classifications, and peak solder temperature.

(4) There may be additional marking, which relates to the logo, the lot trace code information, or the environmental category on the device.

(5) Multiple Device Markings will be inside parentheses. Only one Device Marking contained in parentheses and separated by a "~" will appear on a device. If a line is indented then it is a continuation of the previous line and the two combined represent the entire Device Marking for that device.

(6) Lead finish/Ball material - Orderable Devices may have multiple material finish options. Finish options are separated by a vertical ruled line. Lead finish/Ball material values may wrap to two lines if the finish value exceeds the maximum column width.

Important Information and Disclaimer:The information provided on this page represents TI's knowledge and belief as of the date that it is provided. TI bases its knowledge and belief on information provided by third parties, and makes no representation or warranty as to the accuracy of such information. Efforts are underway to better integrate information from third parties. TI has taken and continues to take reasonable steps to provide representative and accurate information but may not have conducted destructive testing or chemical analysis on incoming materials and chemicals. TI and TI suppliers consider certain information to be proprietary, and thus CAS numbers and other limited information may not be available for release.

In no event shall TI's liability arising out of such information exceed the total purchase price of the TI part(s) at issue in this document sold by TI to Customer on an annual basis.

TAPE AND REEL INFORMATION

QUADRANT ASSIGNMENTS FOR PIN 1 ORIENTATION IN TAPE

*All dimensions are nominal

Device	Package Type	Package Drawing	Pins	SPQ	Reel Diameter (mm)	Reel Width W1 (mm)	A0 (mm)	B0 (mm)	K0 (mm)	P1 (mm)	W (mm)	Pin1 Quadrant
TPS65138ADRCR	VSON	DRC	10	3000	330.0	12.4	3.3	3.3	1.1	8.0	12.0	Q2
TPS65138DRCR	VSON	DRC	10	3000	330.0	12.4	3.3	3.3	1.1	8.0	12.0	Q2

TAPE AND REEL BOX DIMENSIONS

*All dimensions are nominal

Device	Package Type	Package Drawing	Pins	SPQ	Length (mm)	Width (mm)	Height (mm)
TPS65138ADRCR	VSON	DRC	10	3000	552.0	367.0	36.0
TPS65138DRCR	VSON	DRC	10	3000	552.0	367.0	36.0

TUBE

*All dimensions are nominal

Device	Package Name	Package Type	Pins	SPQ	L (mm)	W (mm)	T (μm)	B (mm)
TPS65138ADRCR	DRC	VSON	10	3000	381	4.83	2286	0
TPS65138DRCR	DRC	VSON	10	3000	381	4.83	2286	0

GENERIC PACKAGE VIEW

DRC 10

VSON - 1 mm max height

3 x 3, 0.5 mm pitch

PLASTIC SMALL OUTLINE - NO LEAD

This image is a representation of the package family, actual package may vary.
Refer to the product data sheet for package details.

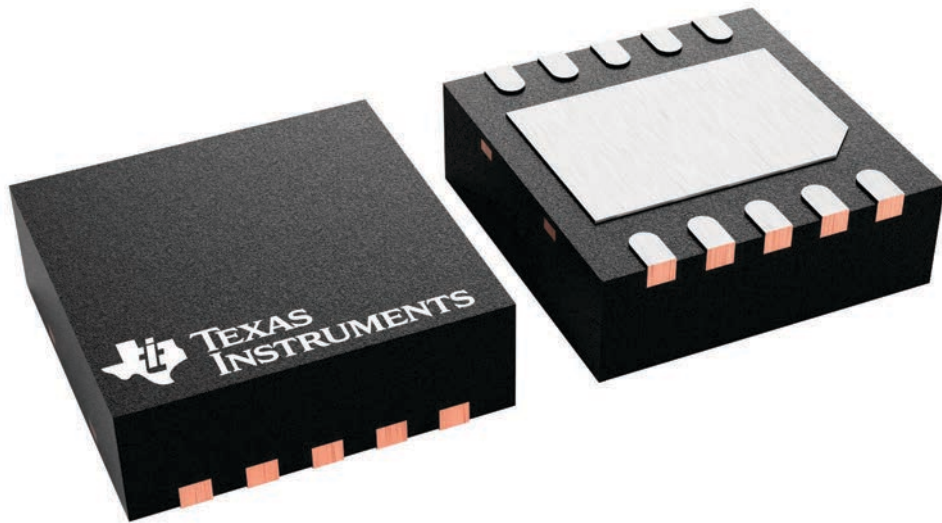

4226193/A

EXAMPLE BOARD LAYOUT

DRC0010J

VSON - 1 mm max height

PLASTIC SMALL OUTLINE - NO LEAD

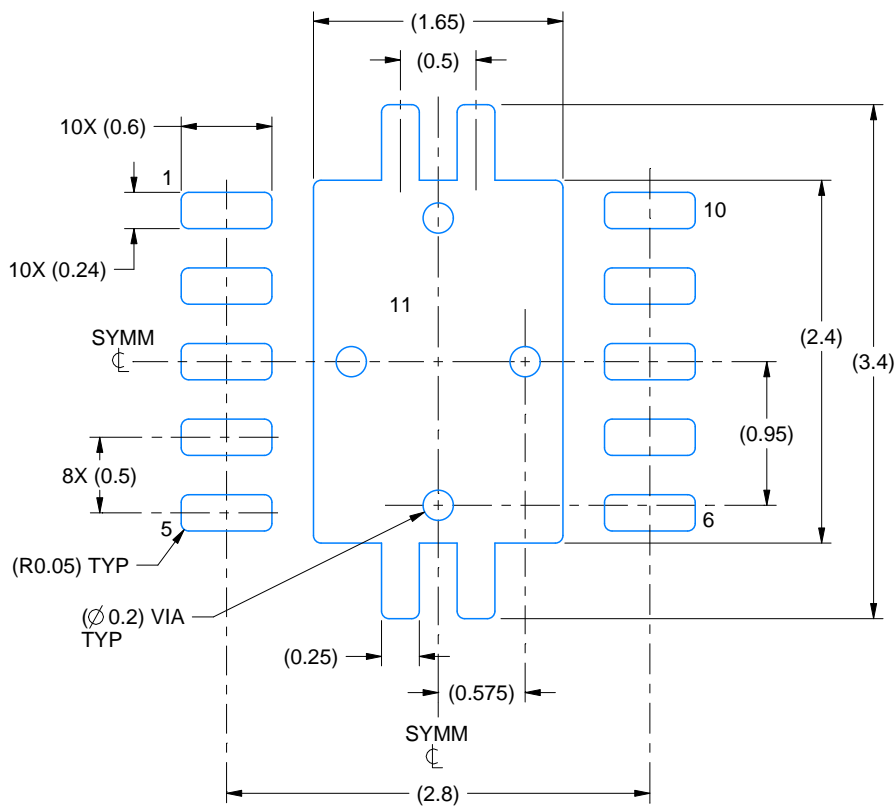

LAND PATTERN EXAMPLE
EXPOSED METAL SHOWN
SCALE:20X

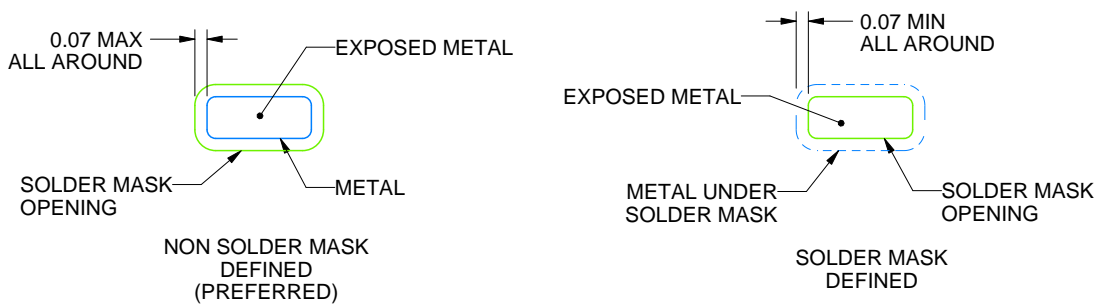

SOLDER MASK DETAILS

4218878/B 07/2018

NOTES: (continued)

4. This package is designed to be soldered to a thermal pad on the board. For more information, see Texas Instruments literature number SLUA271 (www.ti.com/lit/sluea271).
5. Vias are optional depending on application, refer to device data sheet. If any vias are implemented, refer to their locations shown on this view. It is recommended that vias under paste be filled, plugged or tented.

IMPORTANT NOTICE AND DISCLAIMER

TI PROVIDES TECHNICAL AND RELIABILITY DATA (INCLUDING DATA SHEETS), DESIGN RESOURCES (INCLUDING REFERENCE DESIGNS), APPLICATION OR OTHER DESIGN ADVICE, WEB TOOLS, SAFETY INFORMATION, AND OTHER RESOURCES "AS IS" AND WITH ALL FAULTS, AND DISCLAIMS ALL WARRANTIES, EXPRESS AND IMPLIED, INCLUDING WITHOUT LIMITATION ANY IMPLIED WARRANTIES OF MERCHANTABILITY, FITNESS FOR A PARTICULAR PURPOSE OR NON-INFRINGEMENT OF THIRD PARTY INTELLECTUAL PROPERTY RIGHTS.

These resources are intended for skilled developers designing with TI products. You are solely responsible for (1) selecting the appropriate TI products for your application, (2) designing, validating and testing your application, and (3) ensuring your application meets applicable standards, and any other safety, security, regulatory or other requirements.

These resources are subject to change without notice. TI grants you permission to use these resources only for development of an application that uses the TI products described in the resource. Other reproduction and display of these resources is prohibited. No license is granted to any other TI intellectual property right or to any third party intellectual property right. TI disclaims responsibility for, and you will fully indemnify TI and its representatives against, any claims, damages, costs, losses, and liabilities arising out of your use of these resources.

TI's products are provided subject to [TI's Terms of Sale](#) or other applicable terms available either on ti.com or provided in conjunction with such TI products. TI's provision of these resources does not expand or otherwise alter TI's applicable warranties or warranty disclaimers for TI products.

TI objects to and rejects any additional or different terms you may have proposed.

Mailing Address: Texas Instruments, Post Office Box 655303, Dallas, Texas 75265
Copyright © 2022, Texas Instruments Incorporated