

SN74F377A OCTAL D-TYPE FLIP-FLOP WITH CLOCK ENABLE

SDFS018D – D2932, MARCH 1987 – REVISED OCTOBER 1993

- Contains Eight D-Type Flip-Flops With Single-Rail Outputs
- Clock Enable Latched to Avoid False Clocking
- Applications Include:
 - Buffer/Storage Registers
 - Shift Registers
 - Pattern Generators
- Buffered Common Enable Input
- Package Options Include Plastic Small-Outline Packages and Standard Plastic 300-mil DIPs

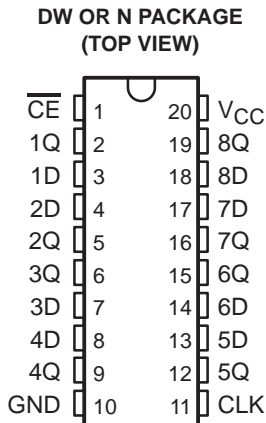

description

The SN74F377A is a monolithic, positive-edge-triggered, octal, D-type flip-flop with clock enable inputs. The SN74F377A features a latched clock enable (\overline{CE}) input.

Information at the data (D) inputs meeting the setup time requirements is transferred to the Q outputs on the positive-going edge of the clock pulse if \overline{CE} is low. Clock triggering occurs at a particular voltage level and is not directly related to the positive-going pulse. When the clock input is at either the high or low level, the D input signal has no effect at the output. The circuits are designed to prevent false clocking by transitions at the \overline{CE} input.

The SN74F377A is characterized for operation from 0°C to 70°C.

**FUNCTION TABLE
(each flip-flop)**

INPUTS			OUTPUT
\overline{CE}	CLK	D	Q
H	X	X	Q ₀
L	↑	H	H
L	↑	L	L
X	L	X	Q ₀

SN74F377A OCTAL D-TYPE FLIP-FLOP WITH CLOCK ENABLE

SDFS018D – D2932, MARCH 1987 – REVISED OCTOBER 1993

logic symbol†

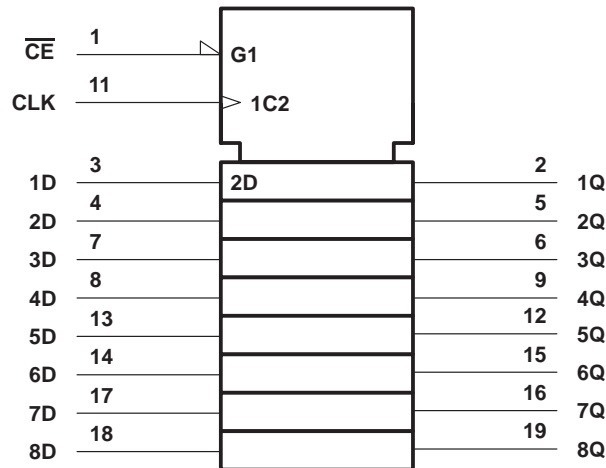

† This symbol is in accordance with ANSI/IEEE Std 91-1984 and IEC Publication 617-12.

logic diagram (positive logic)

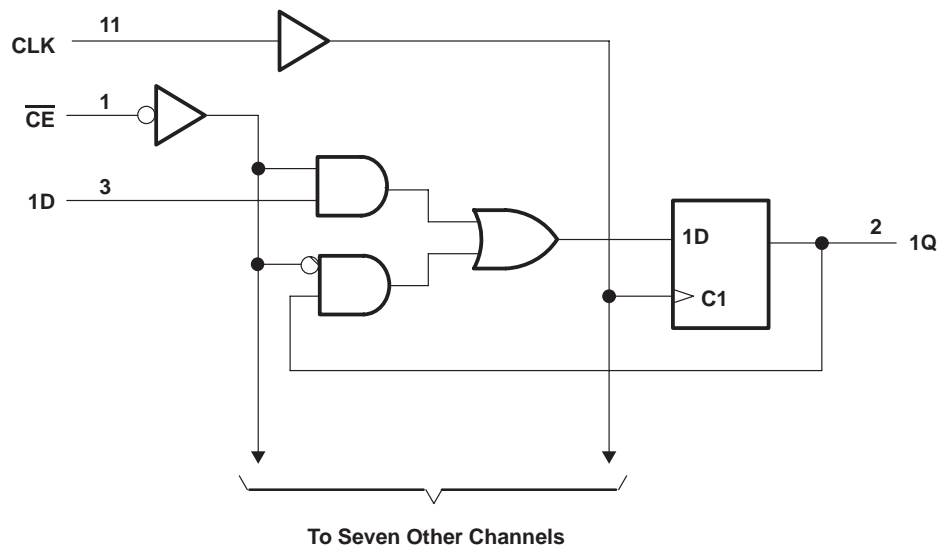

absolute maximum ratings over operating free-air temperature range (unless otherwise noted)‡

Supply voltage range, V_{CC}	-0.5 V to 7 V
Input voltage range, V_I (see Note 1)	-1.2 V to 7 V
Input current range	-30 mA to 5 mA
Voltage range applied to any output in the high state	-0.5 V to V_{CC}
Current into any output in the low state	40 mA
Operating free-air temperature range	0°C to 70°C
Storage temperature range	-65°C to 150°C

‡ Stresses beyond those listed under "absolute maximum ratings" may cause permanent damage to the device. These are stress ratings only, and functional operation of the device at these or any other conditions beyond those indicated under "recommended operating conditions" is not implied. Exposure to absolute-maximum-rated conditions for extended periods may affect device reliability.

NOTE 1: The input-voltage ratings may be exceeded provided the input-current ratings are observed.



POST OFFICE BOX 655303 • DALLAS, TEXAS 75265

SN74F377A OCTAL D-TYPE FLIP-FLOP WITH CLOCK ENABLE

SDFS018D – D2932, MARCH 1987 – REVISED OCTOBER 1993

recommended operating conditions

		MIN	NOM	MAX	UNIT
V_{CC}	Supply voltage	4.5	5	5.5	V
V_{IH}	High-level input voltage	2			V
V_{IL}	Low-level input voltage			0.8	V
I_{IK}	Input clamp current			-18	mA
I_{OH}	High-level output current			-1	mA
I_{OL}	Low-level output current			20	mA
T_A	Operating free-air temperature	0		70	°C

electrical characteristics over recommended operating free-air temperature range (unless otherwise noted)

PARAMETER	TEST CONDITIONS		MIN	TYP†	MAX	UNIT
V_{OH}	$V_{CC} = 4.5\text{ V}$,	$I_{OH} = -1\text{ mA}$	2.5	3.4		V
	$V_{CC} = 4.75\text{ V}$,	$I_{OH} = -1\text{ mA}$	2.7			
V_{OL}	$V_{CC} = 4.5\text{ V}$,	$I_{OL} = 20\text{ mA}$		0.3	0.5	V
I_I	$V_{CC} = 0$,	$V_I = 7\text{ V}$			0.1	mA
I_{IH}	$V_{CC} = 5.5\text{ V}$,	$V_I = 2.7\text{ V}$			20	μA
I_{IL}	$V_{CC} = 5.5\text{ V}$,	$V_I = 0.5\text{ V}$			-0.6	mA
$I_{OS}‡$	$V_{CC} = 5.5\text{ V}$,	$V_O = 0$	-60		-150	mA
I_{CCH}	$V_{CC} = 5.5\text{ V}$,	See Note 2		55	72	mA
I_{CCL}	$V_{CC} = 5.5\text{ V}$,	See Note 3		70	90	mA

† All typical values are at $V_{CC} = 5\text{ V}$, $T_A = 25^\circ\text{C}$.

‡ Not more than one output should be shorted at a time, and the duration of the short circuit should not exceed one second.

NOTES: 2. I_{CCH} is measured after applying a momentary ground, then 4.5 V, to the clock input with all data inputs at 4.5 V and the enable input at GND.

3. I_{CCL} is measured after applying a momentary ground, then 4.5 V, to the clock input with all data and enable inputs at GND.

timing requirements

		$V_{CC} = 5\text{ V}$, $T_A = 25^\circ\text{C}$		$V_{CC} = 4.5\text{ V to }5.5\text{ V}$, $T_A = \text{MIN to MAX}§$		UNIT
		MIN	MAX	MIN	MAX	
f_{clock}	Clock frequency	0	110	0	110	MHz
t_w	Pulse duration	4		5		ns
t_{su}	Setup time before $\text{CLK}\uparrow$	Data high or low	2	2		ns
		$\overline{\text{CE}}$ high	2.5	2.5		
		$\overline{\text{CE}}$ low	4	4.5		
t_h	Hold time after $\text{CLK}\uparrow$	Data high or low	1	1		ns
		$\overline{\text{CE}}$ high or low	0	0		

§ For conditions shown as MIN or MAX, use the appropriate value specified under recommended operating conditions.



SN74F377A

OCTAL D-TYPE FLIP-FLOP WITH CLOCK ENABLE

SDFS018D – D2932, MARCH 1987 – REVISED OCTOBER 1993

switching characteristics (see Note 4)

PARAMETER	FROM (INPUT)	TO (OUTPUT)	V _{CC} = 5 V, C _L = 50 pF, R _L = 500 Ω, T _A = 25°C			V _{CC} = 4.5 V to 5.5 V, C _L = 50 pF, R _L = 500 Ω, T _A = MIN to MAX †		UNIT
			MIN	TYP	MAX	MIN	MAX	
f _{max}			110	125		110		MHz
t _{PLH}	CLK	Any Q	4	6.5	8.5	4	10	ns
t _{PHL}			4	7	9	4	10.5	

† For conditions shown as MIN or MAX, use the appropriate value specified under recommended operating conditions.

NOTE 4: Load circuit and waveforms are shown in Section 1.

PACKAGING INFORMATION

Orderable Device	Status (1)	Package Type	Package Drawing	Pins	Package Qty	Eco Plan (2)	Lead finish/ Ball material (6)	MSL Peak Temp (3)	Op Temp (°C)	Device Marking (4/5)	Samples
SN74F377ADW	ACTIVE	SOIC	DW	20	25	RoHS & Green	NIPDAU	Level-1-260C-UNLIM	0 to 70	F377A	Samples
SN74F377ADWR	ACTIVE	SOIC	DW	20	2000	RoHS & Green	NIPDAU	Level-1-260C-UNLIM	0 to 70	F377A	Samples
SN74F377AN	ACTIVE	PDIP	N	20	20	RoHS & Non-Green	NIPDAU	N / A for Pkg Type	0 to 70	SN74F377AN	Samples

(1) The marketing status values are defined as follows:

ACTIVE: Product device recommended for new designs.

LIFEBUY: TI has announced that the device will be discontinued, and a lifetime-buy period is in effect.

NRND: Not recommended for new designs. Device is in production to support existing customers, but TI does not recommend using this part in a new design.

PREVIEW: Device has been announced but is not in production. Samples may or may not be available.

OBSOLETE: TI has discontinued the production of the device.

(2) **RoHS:** TI defines "RoHS" to mean semiconductor products that are compliant with the current EU RoHS requirements for all 10 RoHS substances, including the requirement that RoHS substance do not exceed 0.1% by weight in homogeneous materials. Where designed to be soldered at high temperatures, "RoHS" products are suitable for use in specified lead-free processes. TI may reference these types of products as "Pb-Free".

RoHS Exempt: TI defines "RoHS Exempt" to mean products that contain lead but are compliant with EU RoHS pursuant to a specific EU RoHS exemption.

Green: TI defines "Green" to mean the content of Chlorine (Cl) and Bromine (Br) based flame retardants meet JS709B low halogen requirements of <=1000ppm threshold. Antimony trioxide based flame retardants must also meet the <=1000ppm threshold requirement.

(3) MSL, Peak Temp. - The Moisture Sensitivity Level rating according to the JEDEC industry standard classifications, and peak solder temperature.

(4) There may be additional marking, which relates to the logo, the lot trace code information, or the environmental category on the device.

(5) Multiple Device Markings will be inside parentheses. Only one Device Marking contained in parentheses and separated by a "-" will appear on a device. If a line is indented then it is a continuation of the previous line and the two combined represent the entire Device Marking for that device.

(6) Lead finish/Ball material - Orderable Devices may have multiple material finish options. Finish options are separated by a vertical ruled line. Lead finish/Ball material values may wrap to two lines if the finish value exceeds the maximum column width.

Important Information and Disclaimer:The information provided on this page represents TI's knowledge and belief as of the date that it is provided. TI bases its knowledge and belief on information provided by third parties, and makes no representation or warranty as to the accuracy of such information. Efforts are underway to better integrate information from third parties. TI has taken and continues to take reasonable steps to provide representative and accurate information but may not have conducted destructive testing or chemical analysis on incoming materials and chemicals. TI and TI suppliers consider certain information to be proprietary, and thus CAS numbers and other limited information may not be available for release.

In no event shall TI's liability arising out of such information exceed the total purchase price of the TI part(s) at issue in this document sold by TI to Customer on an annual basis.

TAPE AND REEL INFORMATION

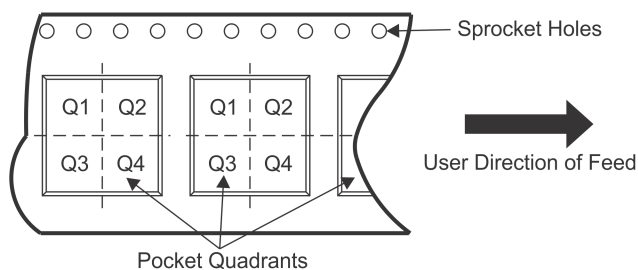
QUADRANT ASSIGNMENTS FOR PIN 1 ORIENTATION IN TAPE

*All dimensions are nominal

Device	Package Type	Package Drawing	Pins	SPQ	Reel Diameter (mm)	Reel Width W1 (mm)	A0 (mm)	B0 (mm)	K0 (mm)	P1 (mm)	W (mm)	Pin1 Quadrant
SN74F377ADWR	SOIC	DW	20	2000	330.0	24.4	10.8	13.3	2.7	12.0	24.0	Q1

TAPE AND REEL BOX DIMENSIONS

*All dimensions are nominal

Device	Package Type	Package Drawing	Pins	SPQ	Length (mm)	Width (mm)	Height (mm)
SN74F377ADWR	SOIC	DW	20	2000	367.0	367.0	45.0

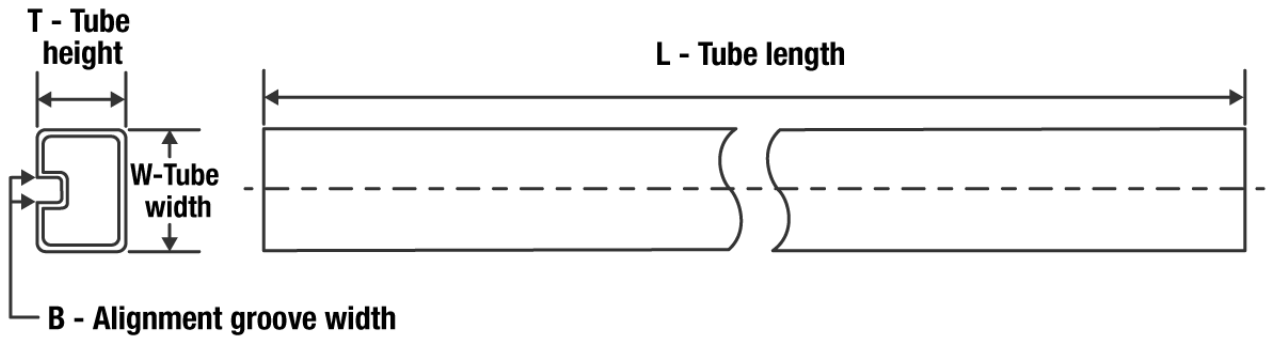
TUBE

*All dimensions are nominal

Device	Package Name	Package Type	Pins	SPQ	L (mm)	W (mm)	T (μm)	B (mm)
SN74F377ADW	DW	SOIC	20	25	507	12.83	5080	6.6
SN74F377AN	N	PDIP	20	20	506	13.97	11230	4.32

N (R-PDIP-T**)

PLASTIC DUAL-IN-LINE PACKAGE

16 PINS SHOWN



- NOTES:
- A. All linear dimensions are in inches (millimeters).
 - B. This drawing is subject to change without notice.
 - Falls within JEDEC MS-001, except 18 and 20 pin minimum body length (Dim A).
 - The 20 pin end lead shoulder width is a vendor option, either half or full width.

DW0020A



PACKAGE OUTLINE

SOIC - 2.65 mm max height

SOIC

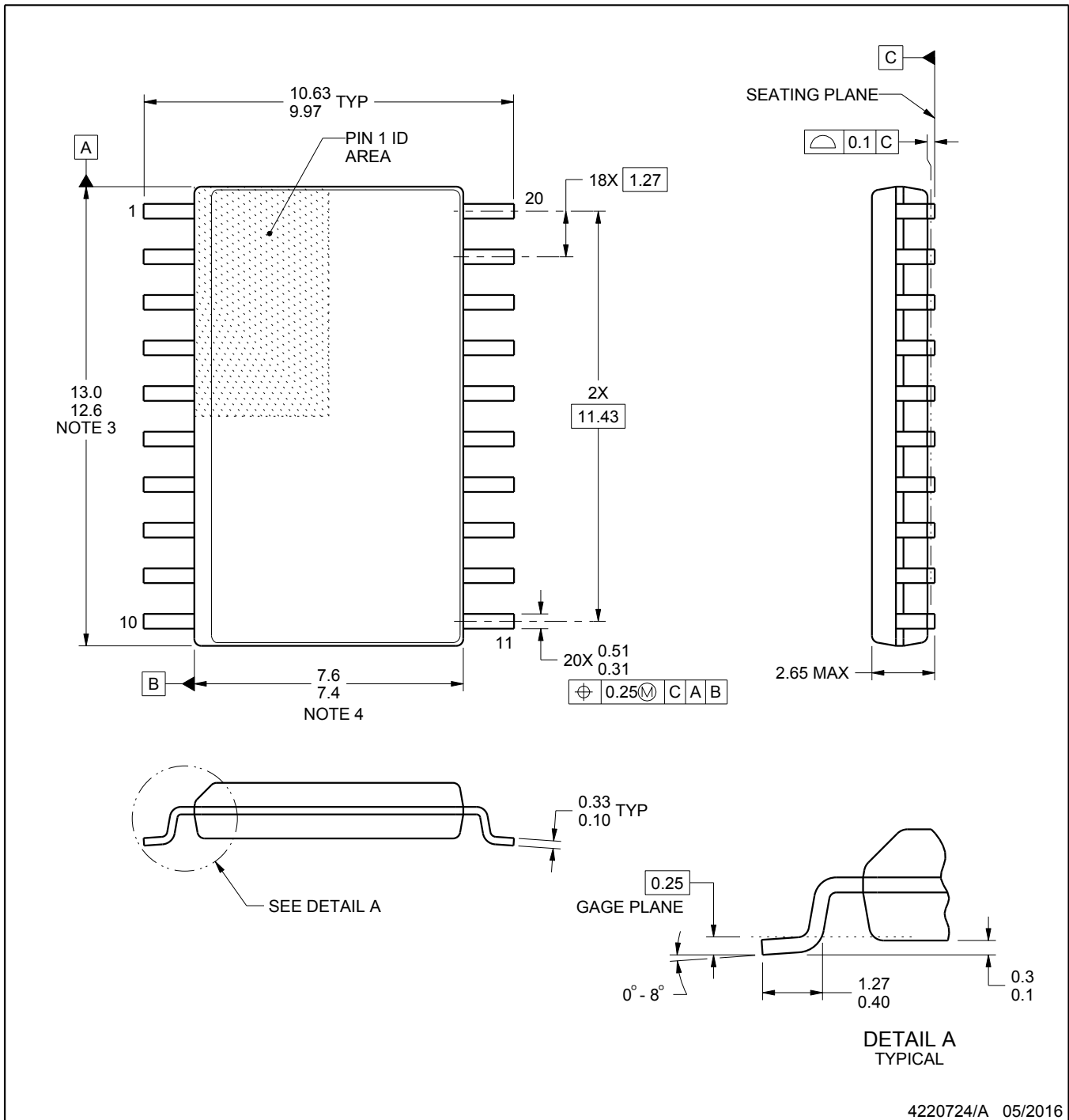

4220724/A 05/2016

NOTES:

- All linear dimensions are in millimeters. Dimensions in parenthesis are for reference only. Dimensioning and tolerancing per ASME Y14.5M.
- This drawing is subject to change without notice.
- This dimension does not include mold flash, protrusions, or gate burrs. Mold flash, protrusions, or gate burrs shall not exceed 0.15 mm per side.
- This dimension does not include interlead flash. Interlead flash shall not exceed 0.43 mm per side.
- Reference JEDEC registration MS-013.

EXAMPLE BOARD LAYOUT

DW0020A

SOIC - 2.65 mm max height

SOIC



LAND PATTERN EXAMPLE
SCALE:6X

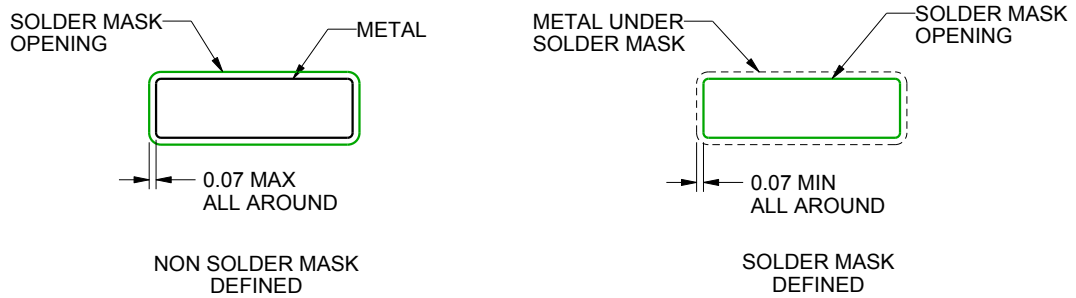

SOLDER MASK DETAILS

4220724/A 05/2016

NOTES: (continued)

- 6. Publication IPC-7351 may have alternate designs.
- 7. Solder mask tolerances between and around signal pads can vary based on board fabrication site.

EXAMPLE STENCIL DESIGN

DW0020A

SOIC - 2.65 mm max height

SOIC

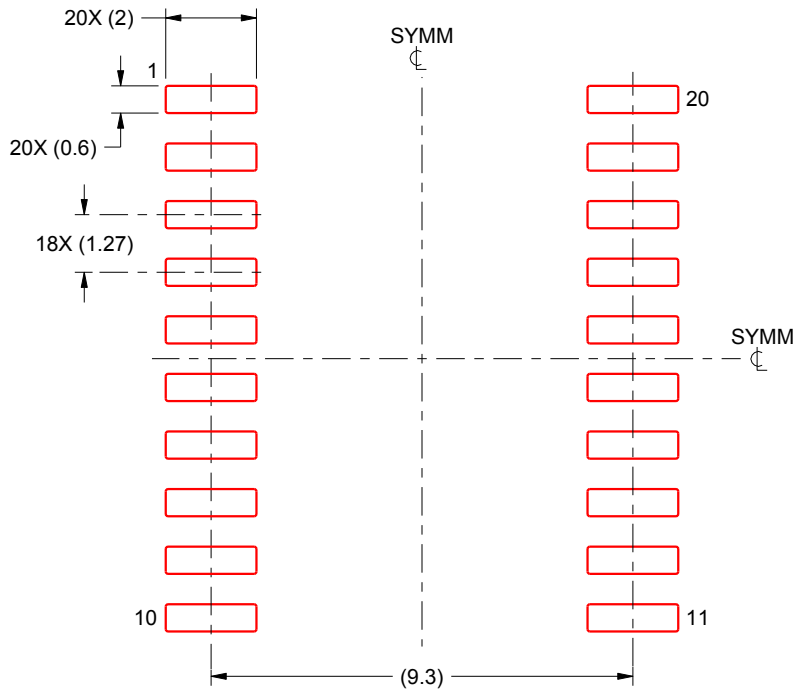

SOLDER PASTE EXAMPLE
BASED ON 0.125 mm THICK STENCIL
SCALE:6X

4220724/A 05/2016

NOTES: (continued)

8. Laser cutting apertures with trapezoidal walls and rounded corners may offer better paste release. IPC-7525 may have alternate design recommendations.
9. Board assembly site may have different recommendations for stencil design.

IMPORTANT NOTICE AND DISCLAIMER

TI PROVIDES TECHNICAL AND RELIABILITY DATA (INCLUDING DATA SHEETS), DESIGN RESOURCES (INCLUDING REFERENCE DESIGNS), APPLICATION OR OTHER DESIGN ADVICE, WEB TOOLS, SAFETY INFORMATION, AND OTHER RESOURCES "AS IS" AND WITH ALL FAULTS, AND DISCLAIMS ALL WARRANTIES, EXPRESS AND IMPLIED, INCLUDING WITHOUT LIMITATION ANY IMPLIED WARRANTIES OF MERCHANTABILITY, FITNESS FOR A PARTICULAR PURPOSE OR NON-INFRINGEMENT OF THIRD PARTY INTELLECTUAL PROPERTY RIGHTS.

These resources are intended for skilled developers designing with TI products. You are solely responsible for (1) selecting the appropriate TI products for your application, (2) designing, validating and testing your application, and (3) ensuring your application meets applicable standards, and any other safety, security, regulatory or other requirements.

These resources are subject to change without notice. TI grants you permission to use these resources only for development of an application that uses the TI products described in the resource. Other reproduction and display of these resources is prohibited. No license is granted to any other TI intellectual property right or to any third party intellectual property right. TI disclaims responsibility for, and you will fully indemnify TI and its representatives against, any claims, damages, costs, losses, and liabilities arising out of your use of these resources.

TI's products are provided subject to [TI's Terms of Sale](#) or other applicable terms available either on ti.com or provided in conjunction with such TI products. TI's provision of these resources does not expand or otherwise alter TI's applicable warranties or warranty disclaimers for TI products.

TI objects to and rejects any additional or different terms you may have proposed.

Mailing Address: Texas Instruments, Post Office Box 655303, Dallas, Texas 75265
Copyright © 2022, Texas Instruments Incorporated