

## 2.95V 至 6V 输入，5A 同步降压 SWIFT™ 转换器

### 特性

- 2 个用于在 5A 负载时获得高效率的 30mΩ (典型值) 金属氧化物半导体场效应晶体管 (MOSFET)
- 200kHz 至 2MHz 的开关频率
- 初始精度为 ±1% 的 0.6V 电压基准
- 可调节的缓启动/排序
- 欠压 (UV) 和过压 (OV) 电源正常输出
- 低运行和关断静态电流
- 安全启动至预偏置输出
- 逐周期电流限制、过温和频率折返保护
- -40°C 至 140°C 的工作结温范围
- 耐热增强型 3mm x 3mm 16 引脚四方扁平无引线 (QFN) 封装

### 应用范围

- 低压、高密度电源系统
- 针对高性能数字信号处理器 (DSP)，现场可编程栅极阵列 (FPGA)，特定用途集成电路 (ASIC)，和微处理器的负载点调节
- 宽带、网络互联及光纤通信基础设施

### 简化的电路原理图

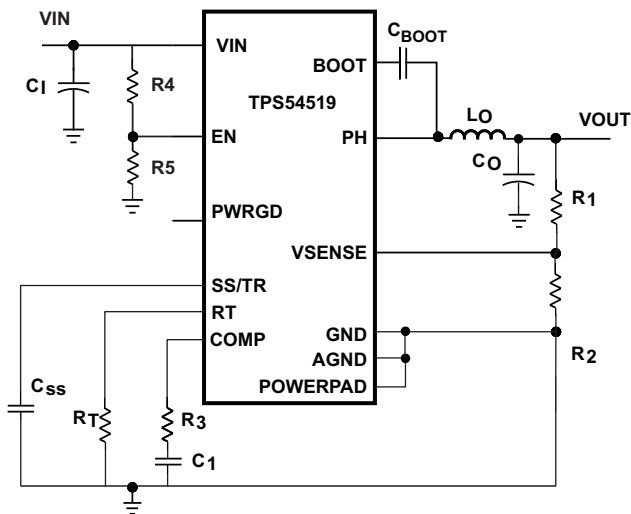

### 说明

TPS54519 器件是一款具有两个集成型 MOSFET 的全功能 6V, 5A, 同步降压电流模式转换器。

TPS54519 通过集成 MOSFET，执行电流模式控制来减少外部组件数量，启用高达 2MHz 的开关频率来减小电感器尺寸，并借助一个小型 3mm x 3mm 耐热增强型 QFN 封装来最大限度地降低 IC 封装尺寸，从而实现小型设计。

通过集成的 30mΩ MOSFET 和典型值为 350μA 的电源电流，效率得以大幅提升。通过使用使能引脚进入关断模式，关断电流可减少至 2μA。

欠压闭锁被内部设定在 2.6V，但是通过一个使能引脚上的电阻器网络来设定阈值可增加此电压值。输出电压启动斜坡由缓启动引脚控制。一个开漏电源正常信号表示输出处于其标称电压的 93% 至 107% 之内。

频率折返和热关断保护功能在过流情况下保护器件不受损坏。

TPS54519 由 SwitcherPro™ 软件工具提供技术支持，此软件工具可从 <http://www.ti.com/switcherpro> 网站内获得。

要获得更多 SWIFT™ 文档，请参见 TI 网站 [www.ti.com/swift](http://www.ti.com/swift)。

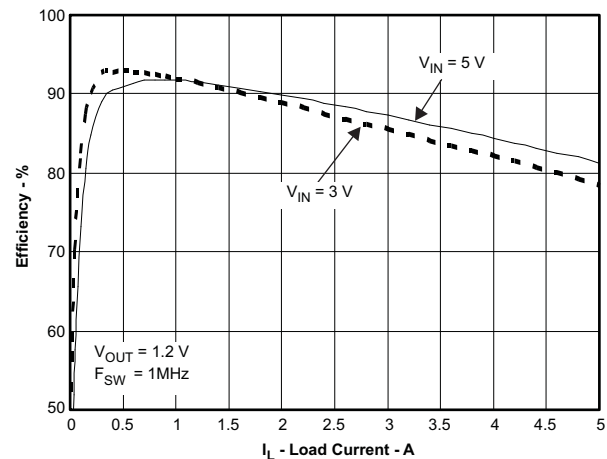

Please be aware that an important notice concerning availability, standard warranty, and use in critical applications of Texas Instruments semiconductor products and disclaimers thereto appears at the end of this data sheet.

SWIFT, SwitcherPro are trademarks of Texas Instruments.



This integrated circuit can be damaged by ESD. Texas Instruments recommends that all integrated circuits be handled with appropriate precautions. Failure to observe proper handling and installation procedures can cause damage.

ESD damage can range from subtle performance degradation to complete device failure. Precision integrated circuits may be more susceptible to damage because very small parametric changes could cause the device not to meet its published specifications.

### ORDERING INFORMATION

T <sub>J</sub>	PACKAGE	PART NUMBER
–40°C to 140°C	3 x 3 mm QFN	TPS54519RTE

### ABSOLUTE MAXIMUM RATINGS

		VALUE		UNIT
		MIN	MAX	
Input voltage	VIN	–0.3	7	V
	EN	–0.3	7	
	BOOT		PH + 8	
	VSENSE	–0.3	3	
	COMP	–0.3	3	
	PWRGD	–0.3	7	
	SS/TR	–0.3	3	
	RT	–0.3	6	
Output voltage	BOOT-PH		8	V
	PH	–0.6	7	
	PH 10 ns Transient	–2	7	
Source current	EN		100	μA
	RT		100	
Sink current	COMP		100	μA
	PWRGD		10	mA
	SS/TR		100	μA
Electrostatic discharge (HBM)			2	kV
Electrostatic discharge (CDM)			500	V
Operating Junction temperature, T <sub>j</sub>		–40	140	°C
Storage temperature, T <sub>stg</sub>		–65	150	°C

### THERMAL INFORMATION

THERMAL METRIC <sup>(1)(2)</sup>		TPS54519	UNITS
		RTE (16 PINS)	
θ <sub>JA</sub>	Junction-to-ambient thermal resistance (standard board)	49.1	°C/W
θ <sub>JA</sub>	Junction-to-ambient thermal resistance (custom board) <sup>(3)</sup>	37.0	
ψ <sub>JT</sub>	Junction-to-top characterization parameter	0.7	
ψ <sub>JB</sub>	Junction-to-board characterization parameter	21.8	
θ <sub>JC(top)</sub>	Junction-to-case(top) thermal resistance	50.7	
θ <sub>JC(bot)</sub>	Junction-to-case(bottom) thermal resistance	7.5	
θ <sub>JB</sub>	Junction-to-board thermal resistance	21.8	

- (1) For more information about traditional and new thermal metrics, see the *IC Package Thermal Metrics* application report, [SPRA953](#).
- (2) Power rating at a specific ambient temperature T<sub>A</sub> should be determined with a junction temperature of 140°C. This is the point where distortion starts to substantially increase. See power dissipation estimate in the application section of this data sheet for more information.
- (3) Test boards conditions:
  - (a) 2 inches x 2 inches, 4 layers, thickness: 0.062 inch
  - (b) 2 oz. copper traces located on the top of the PCB
  - (c) 2 oz. copper ground planes on the 2 internal layers and bottom layer
  - (d) 4 thermal vias (10mil) located under the device package

## ELECTRICAL CHARACTERISTICS

 $T_J = -40^{\circ}\text{C}$  to  $140^{\circ}\text{C}$ ,  $V_{IN} = 2.95$  to  $6$  V (unless otherwise noted)

DESCRIPTION	CONDITIONS	MIN	TYP	MAX	UNIT
<b>SUPPLY VOLTAGE (VIN PIN)</b>					
Operating input voltage		2.95		6	V
Internal under voltage lockout threshold	No voltage hysteresis, rising and falling		2.4	2.8	V
Shutdown supply current	$EN = 0$ V, $25^{\circ}\text{C}$ , $2.95$ V $\leq$ $V_{IN} \leq 6$ V		1	5	$\mu\text{A}$
Quiescent Current - $I_q$	$V_{SENSE} = 0.9$ V, $25^{\circ}\text{C}$ , $RT = 400$ k $\Omega$		455	500	$\mu\text{A}$
<b>ENABLE AND UVLO (EN PIN)</b>					
Enable threshold	Rising	1.16	1.25	1.37	V
	Falling		1.18		
Input current	Enable threshold + 50 mV		-3.6		$\mu\text{A}$
	Enable threshold – 50 mV		-0.7		
<b>VOLTAGE REFERENCE (VSENSE PIN)</b>					
Voltage Reference	$0$ A $\leq I_{OUT} \leq 5$ A, $25^{\circ}\text{C}$	0.594	0.600	0.606	V
<b>MOSFET</b>					
High side switch resistance	BOOT-PH= 5 V		30	60	m $\Omega$
	BOOT-PH= 2.95 V		35	70	
Low side switch resistance	VIN= 5 V		30	60	m $\Omega$
	VIN= 2.95 V		35	70	
<b>ERROR AMPLIFIER</b>					
Input current			50		nA
Error amplifier transconductance (gm)	$-2$ $\mu\text{A} < I(\text{COMP}) < 2$ $\mu\text{A}$ , $V(\text{COMP}) = 1$ V		250		$\mu\text{mhos}$
Error amplifier transconductance (gm) during slow start	$-2$ $\mu\text{A} < I(\text{COMP}) < 2$ $\mu\text{A}$ , $V(\text{COMP}) = 1$ V, $V_{sense} = 0.4$ V		85		$\mu\text{mhos}$
Error amplifier source/sink	$V(\text{COMP}) = 1$ V, 100 mV overdrive		$\pm 20$		$\mu\text{A}$
COMP to Iswitch gm			19.0		A/V
<b>CURRENT LIMIT</b>					
Current limit threshold		6.0	7.0	8.0	A
Low-side reverse current limit			-2.7		A
<b>THERMAL SHUTDOWN</b>					
Thermal Shutdown		150	155		$^{\circ}\text{C}$
Hysteresis			7.5		$^{\circ}\text{C}$
<b>TIMING RESISTOR (RT PIN)</b>					
Switching frequency range using RT mode		200		2000	kHz
Switching frequency	$R_t = 84$ k $\Omega$	400	490	600	kHz
<b>PH (PH PIN)</b>					
Minimum On time	Measured at 50% points on PH, $V_{IN} = 5$ V, $I_{OUT} = 500$ mA		100		ns
Minimum Off time	Prior to skipping off pulses, BOOT-PH = 2.95 V, $I_{OUT} = 4$ A		60		ns
Rise/Fall Time	$V_{IN} = 5$ V		1.5		V/ns

**ELECTRICAL CHARACTERISTICS (continued)**T<sub>J</sub> = –40°C to 140°C, V<sub>IN</sub> = 2.95 to 6 V (unless otherwise noted)

DESCRIPTION	CONDITIONS	MIN	TYP	MAX	UNIT
<b>BOOT (BOOT PIN)</b>					
BOOT Charge Resistance	V <sub>IN</sub> = 5 V		15		Ω
BOOT-PH UVLO	V <sub>IN</sub> = 2.95 V		2.1	2.75	V
<b>SLOW START / TRACKING (SS/TR PIN)</b>					
Charge Current	V(SS) = 0.3 V		2.4		μA
SS/TR to VSENSE matching	V <sub>SSTR</sub> = 0.3 V		73	115	mV
SS to reference crossover	98% nominal		0.87		V
SS discharge voltage (overload)	VSENSE = 0 V		80		μA
SS discharge current (UVLO, EN, Thermal Fault)	V <sub>IN</sub> = 5 V, V(SS) = 0.5 V		1.2		mA
<b>POWER GOOD (PWRGD PIN)</b>					
VSENSE threshold	VSENSE rising (Good)		93		% V <sub>ref</sub>
	VSENSE rising (Fault)		110		% V <sub>ref</sub>
Hysteresis	VSENSE falling		2		% V <sub>ref</sub>
Output high leakage	VSENSE = V <sub>REF</sub> , V(PWRGD) = 5.5 V		100		nA
On resistance			78		Ω
Output low	I(PWRGD) = 3.5 mA			0.5	V
Minimum V <sub>IN</sub> for valid output	V(PWRGD) < 0.5 V at 100 μA			0.8	V

**DEVICE INFORMATION**

**PIN CONFIGURATION**

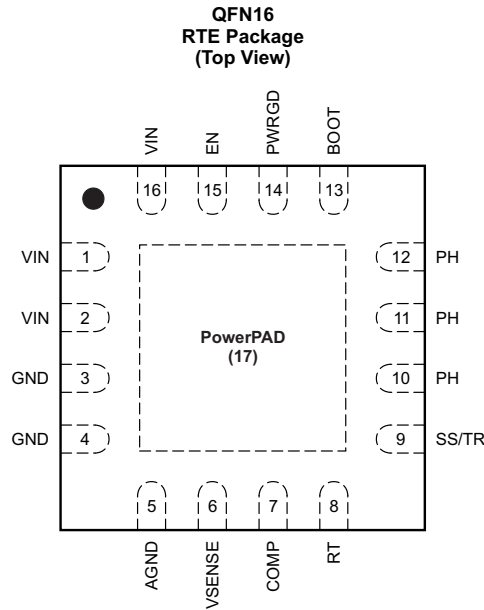

**PIN FUNCTIONS**

PIN		DESCRIPTION
NAME	NO.	
AGND	5	Analog Ground should be electrically connected to GND close to the device.
BOOT	13	A bootstrap capacitor is required between BOOT and PH. If the voltage on this capacitor is below the minimum required by the BOOT UVLO, the output is forced to switch off until the capacitor is refreshed.
COMP	7	Error amplifier output, and input to the output switch current comparator. Connect frequency compensation components to this pin.
EN	15	Enable pin, internal pull-up current source. Pull below 1.18 V to disable. Float to enable. Can be used to set the on/off threshold (adjust UVLO) with two additional resistors.
GND	3, 4	Power Ground. This pin should be electrically connected directly to the power pad under the IC.
PH	10, 11, 12	The source of the internal high side power MOSFET, and drain of the internal low side (synchronous) rectifier MOSFET.
Thermal Pad	17	GND pin should be connected to the exposed power pad for proper operation. This thermal pad should be connected to any internal PCB ground plane using multiple vias for good thermal performance.
PWRGD	14	An open drain output, asserts low if output voltage is low due to thermal shutdown, overcurrent, over/under-voltage or EN shut down.
RT	8	Resistor Timing.
SS/TR	9	Slow-start. An external capacitor connected to this pin sets the output voltage rise time. This pin can also be used for tracking.
VIN	1, 2, 16	Input supply voltage, 2.95 V to 6 V.
VSENSE	6	Inverting node of the transconductance (gm) error amplifier.

FUNCTIONAL BLOCK DIAGRAM

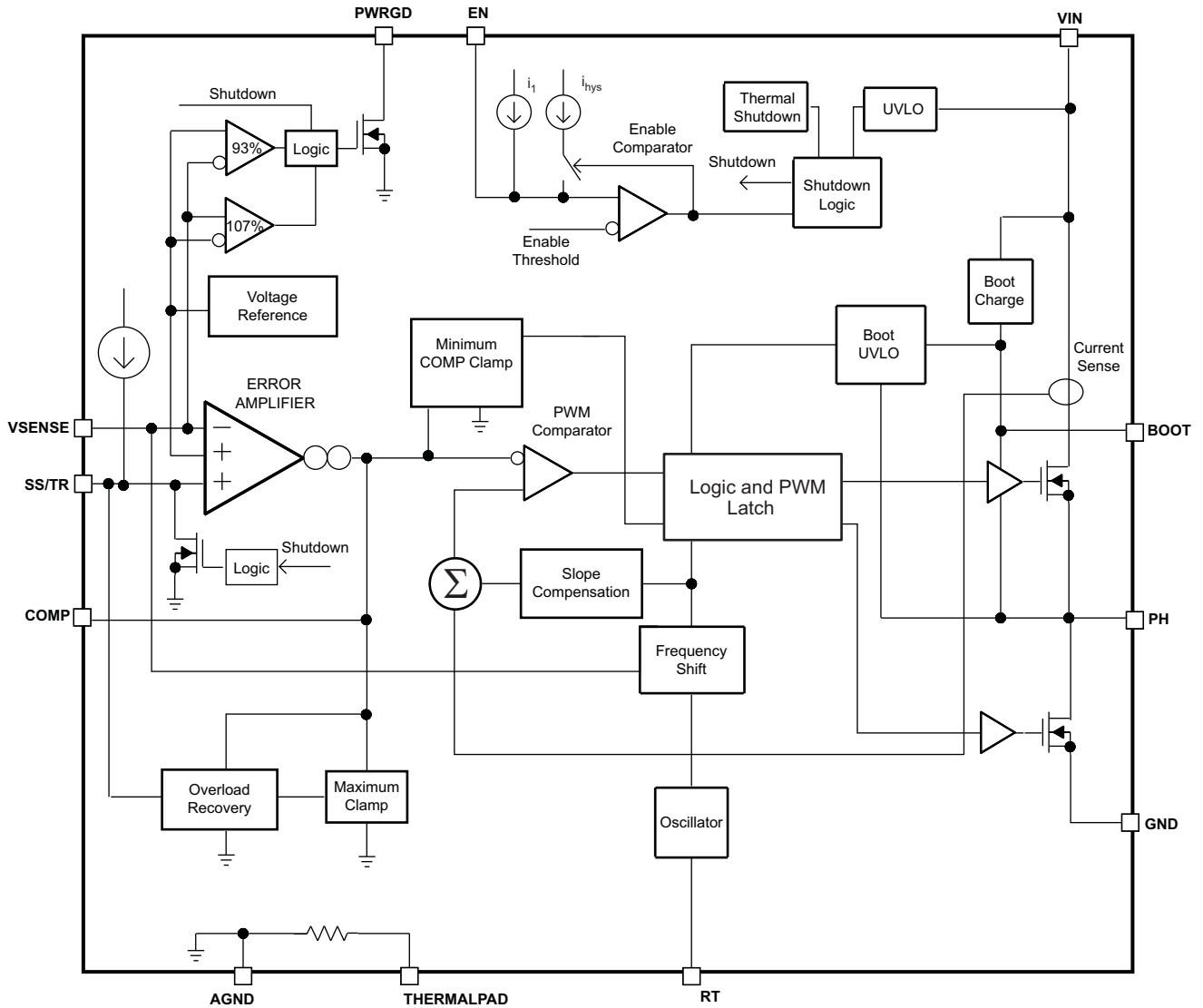

### TYPICAL CHARACTERISTICS CURVES

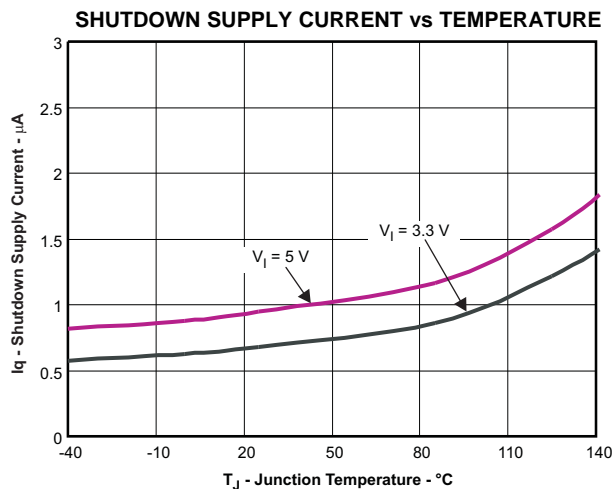

Figure 1.

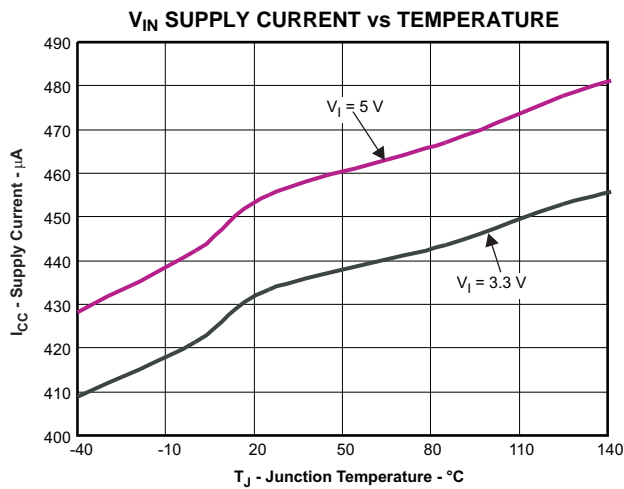

Figure 2.

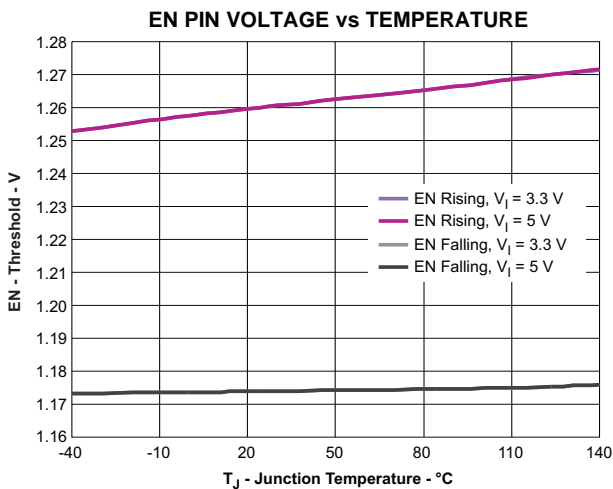

Figure 3.

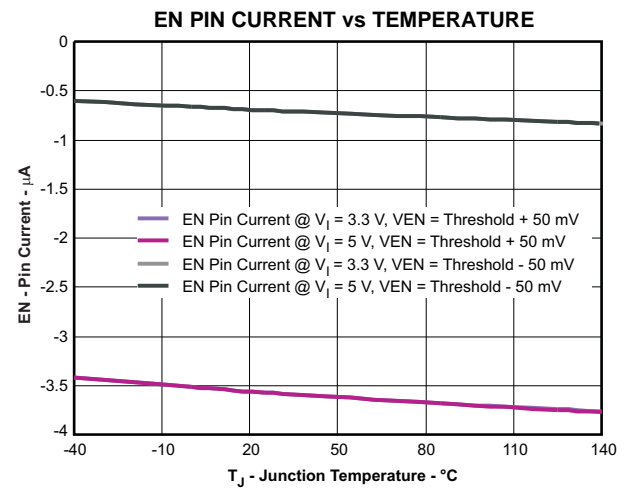

Figure 4.

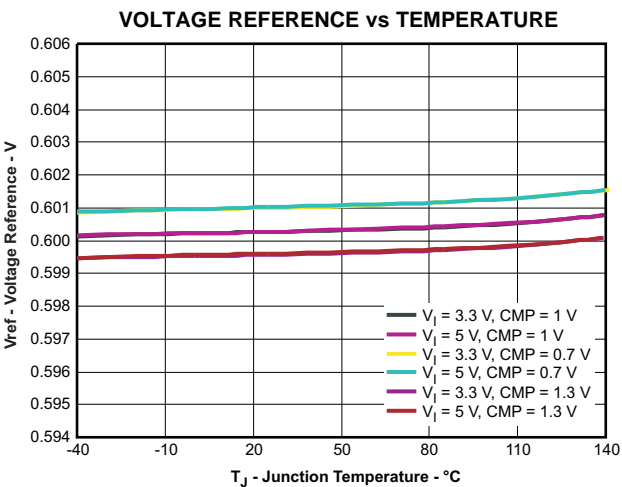

Figure 5.

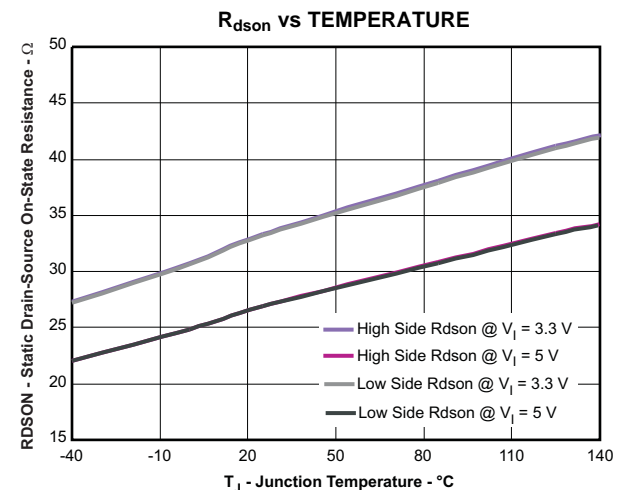

Figure 6.

**TYPICAL CHARACTERISTICS CURVES (continued)**

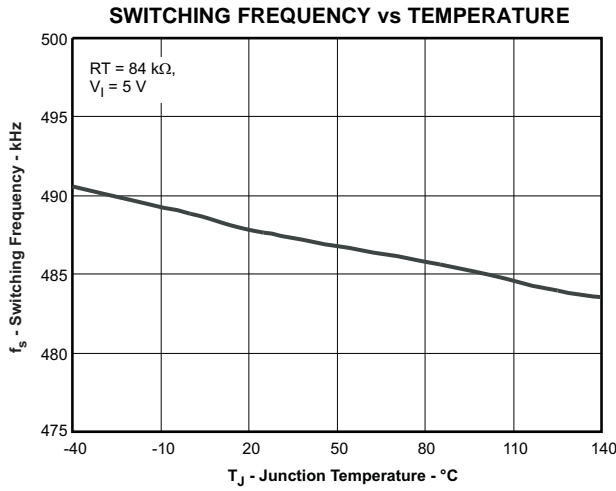

Figure 7.

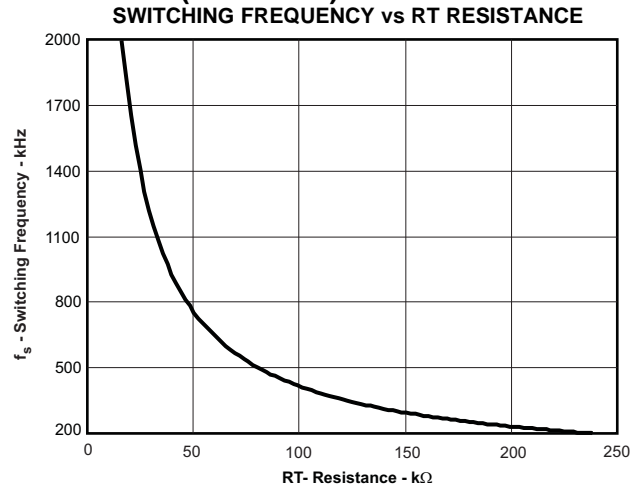

Figure 8.

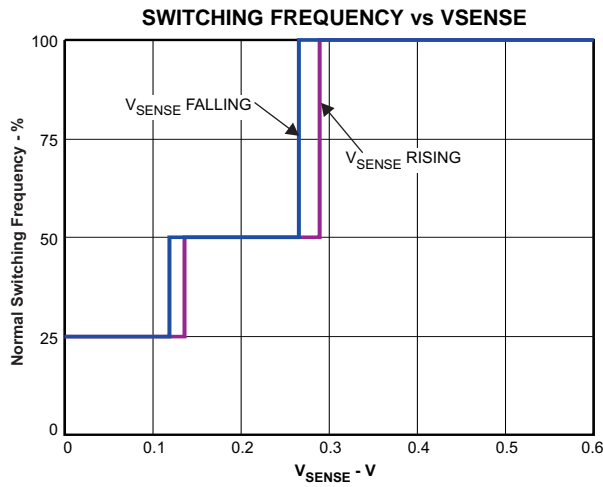

Figure 9.

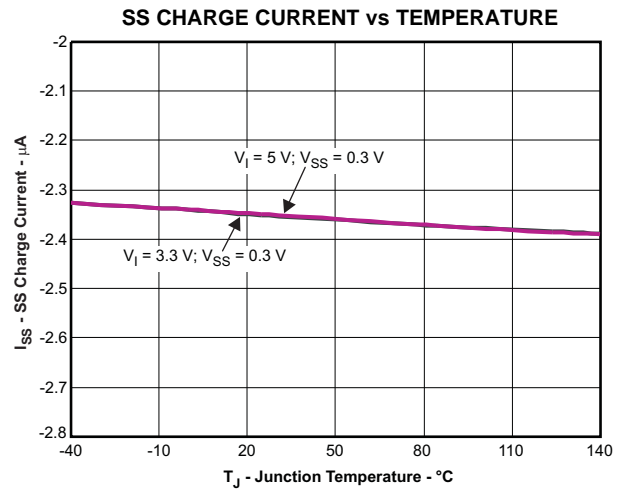

Figure 10.

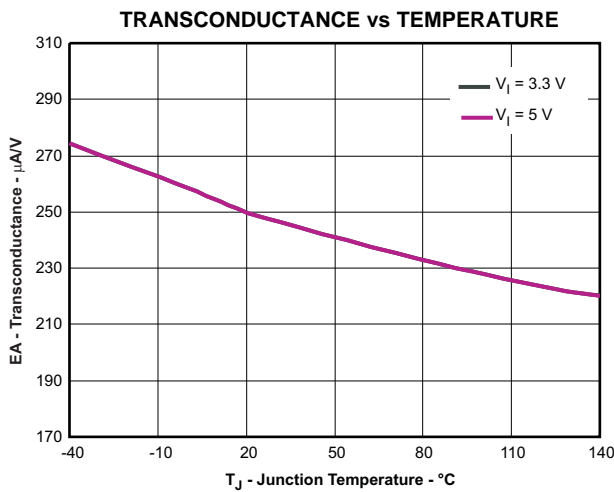

Figure 11.

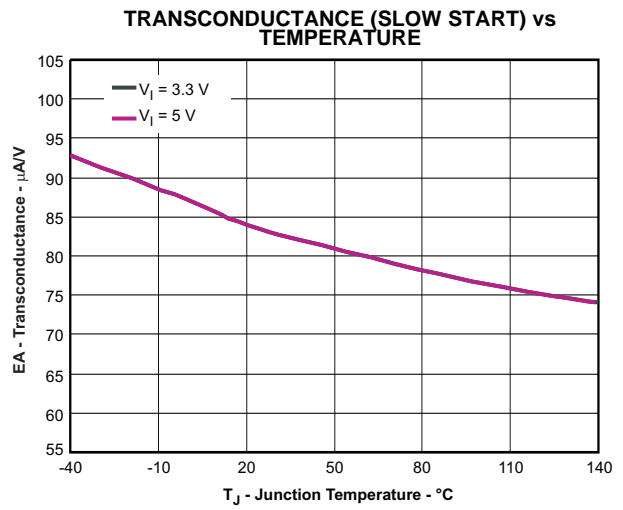

Figure 12.

**TYPICAL CHARACTERISTICS CURVES (continued)**

**HIGH-SIDE FET CURRENT LIMIT vs TEMPERATURE**

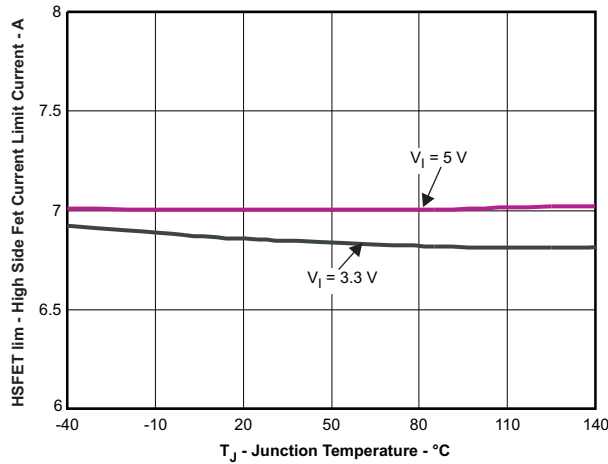

Figure 13.

**PWRGD Rds(on) vs TEMPERATURE**

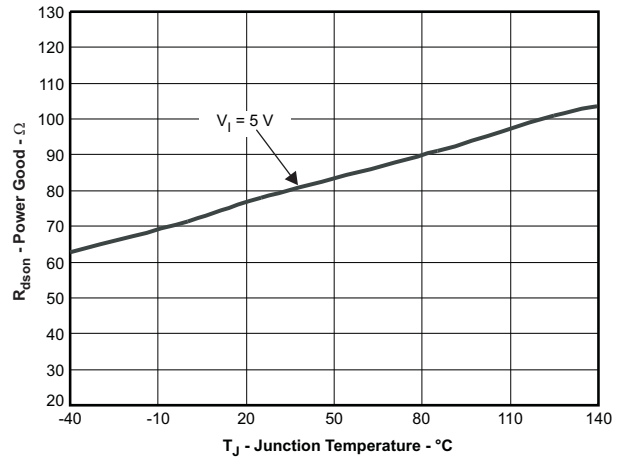

Figure 14.

**PWRGD THRESHOLD vs TEMPERATURE**

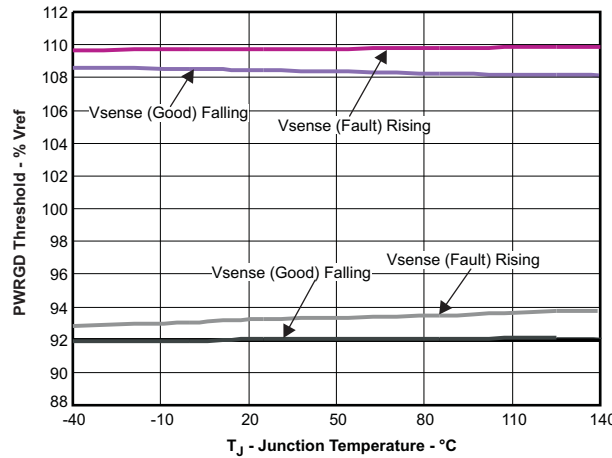

Figure 15.

**OVERVIEW**

The TPS54519 is a 6-V, 5-A, synchronous step-down (buck) converter with two integrated n-channel MOSFETs. To improve performance during line and load transients the device implements a constant frequency, peak current mode control which reduces output capacitance and simplifies external frequency compensation design. The wide switching frequency of 200 kHz to 2000 kHz allows for efficiency and size optimization when selecting the output filter components. The switching frequency is adjusted using a resistor to ground on the RT pin.

The TPS54519 has a typical default start up voltage of 2.6 V. The EN pin has an internal pull-up current source that can be used to adjust the input voltage under voltage lockout (UVLO) with two external resistors. In addition, the pull up current provides a default condition when the EN pin is floating for the device to operate. The total operating current for the TPS54519 is 455  $\mu$ A when not switching and under no load. When the device is disabled, the supply current is less than 5  $\mu$ A.

The integrated 30 m $\Omega$  MOSFETs allow for high efficiency power supply designs with continuous output currents up to 5 amperes.

The TPS54519 reduces the external component count by integrating the boot recharge diode. The bias voltage for the integrated high side MOSFET is supplied by a capacitor on the BOOT to PH pin. The boot capacitor voltage is monitored by an UVLO circuit and turns off the high side MOSFET when the voltage falls below a preset threshold. This BOOT circuit allows the TPS54519 to operate approaching 100%. The output voltage can be stepped down to as low as the 0.6 V reference.

The TPS54519 has a power good comparator (PWRGD) with 2% hysteresis.

The TPS54519 minimizes excessive output overvoltage transients by taking advantage of the overvoltage power good comparator. When the regulated output voltage is greater than 107% of the nominal voltage, the overvoltage comparator is activated, and the high side MOSFET is turned off and masked from turning on until the output voltage is lower than 105%.

The SS/TR pin is used to minimize inrush currents or provide power supply sequencing during power up. A small value capacitor should be coupled to the pin for slow start. The SS/TR pin is discharged before the output power up to ensure a repeatable restart after an over-temperature fault, UVLO fault or disabled condition.

The use of a frequency foldback circuit reduces the switching frequency during startup and over current fault conditions to help limit the inductor current.

## DETAILED DESCRIPTION

### FIXED FREQUENCY PWM CONTROL

The TPS54519 uses an adjustable fixed frequency, peak current mode control. The output voltage is compared through external resistors on the VSENSE pin to an internal voltage reference by an error amplifier which drives the COMP pin. An internal oscillator initiates the turn on of the high side power switch. The error amplifier output is compared to the high side power switch current. When the power switch current reaches the COMP voltage level the high side power switch is turned off and the low side power switch is turned on. The COMP pin voltage increases and decreases as the output current increases and decreases. The device implements a current limit by clamping the COMP pin voltage to a maximum level and also implements a minimum clamp for improved transient response performance.

### SLOPE COMPENSATION AND OUTPUT CURRENT

The TPS54519 adds a compensating ramp to the switch current signal. This slope compensation prevents sub-harmonic oscillations as duty cycle increases. The available peak inductor current remains constant over the full duty cycle range.

### BOOTSTRAP VOLTAGE (BOOT) AND LOW DROPOUT OPERATION

The TPS54519 has an integrated boot regulator and requires a small ceramic capacitor between the BOOT and PH pin to provide the gate drive voltage for the high side MOSFET. The value of the ceramic capacitor should be 0.1  $\mu\text{F}$ . A ceramic capacitor with an X7R or X5R grade dielectric with a voltage rating of 10 V or higher is recommended because of the stable characteristics over temperature and voltage.

To improve drop out, the TPS54519 is designed to operate at 100% duty cycle as long as the BOOT to PH pin voltage is greater than 2.1 V, typically. The high side MOSFET is turned off using an UVLO circuit, allowing for the low side MOSFET to conduct when the voltage from BOOT to PH drops below 2.1 V. Since the supply current sourced from the BOOT pin is very low, the high side MOSFET can remain on for more switching cycles than are required to refresh the capacitor, thus the effective duty cycle of the switching regulator is very high.

### ERROR AMPLIFIER

The TPS54519 has a transconductance amplifier. The error amplifier compares the VSENSE voltage to the lower of the SS/TR pin voltage or the internal 0.6 V voltage reference. The transconductance of the error amplifier is 250  $\mu\text{A/V}$  during normal operation. When the voltage of VSENSE pin is below 0.6 V and the device is regulating using the SS/TR voltage, the gm is 85  $\mu\text{A/V}$ . The frequency compensation components are placed between the COMP pin and ground.

### VOLTAGE REFERENCE

The voltage reference system produces 0.6 V Voltage Reference at the non-inverting input of the error amplifier.

### ADJUSTING THE OUTPUT VOLTAGE

The output voltage is set with a resistor divider from the output node to the VSENSE pin. It is recommended to use divider resistors with 1% tolerance or better. Start with a 100 k $\Omega$  for the R1 resistor and use the [Equation 1](#) to calculate R2. To improve efficiency at very light loads consider using larger value resistors. If the values are too high the regulator is more susceptible to noise and voltage errors from the VSENSE input current are noticeable.

$$R2 = R1 \times \left( \frac{0.6 \text{ V}}{V_o - 0.6 \text{ V}} \right) \quad (1)$$

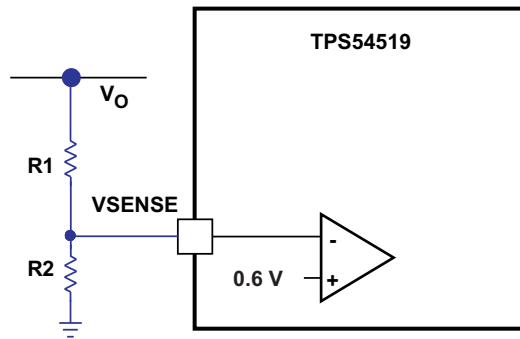

Figure 16. Voltage Divider Circuit

**ENABLE AND ADJUSTING UNDER-VOLTAGE LOCKOUT**

The TPS54519 is disabled when the VIN pin voltage falls below 2.6 V. If an application requires a higher under-voltage lockout (UVLO), use the EN pin as shown in Figure 17 to adjust the input voltage UVLO by using two external resistors. It is recommended to use the enable resistors to set the UVLO falling threshold (V\_STOP) above 2.7 V. The rising threshold (V\_START) should be set to provide enough hysteresis to allow for any input supply variations. The EN pin has an internal pull-up current source that provides the default condition of the TPS54519 operating when the EN pin floats. Once the EN pin voltage exceeds 1.25 V, an additional 2.9 μA of hysteresis is added. When the EN pin is pulled below 1.18 V, the 2.9 μA is removed. This additional current facilitates input voltage hysteresis.

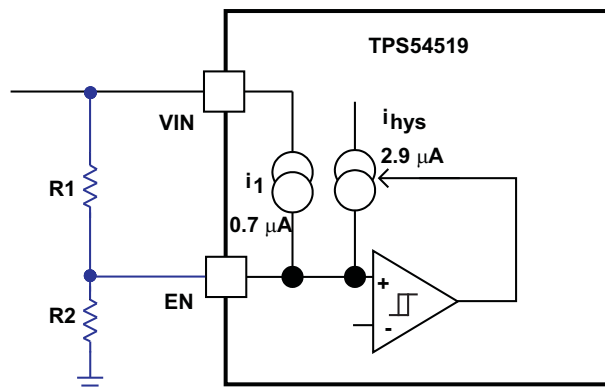

Figure 17. Adjustable Under Voltage Lock Out

$$R1 = \frac{V_{START} \left( \frac{V_{ENFALLING}}{V_{ENRISING}} \right) - V_{STOP}}{I_P \left( 1 - \frac{V_{ENFALLING}}{V_{ENRISING}} \right) + I_h} \tag{2}$$

$$R2 = \frac{R1 \times V_{ENFALLING}}{V_{STOP} - V_{ENFALLING} + R1(I_P + I_h)} \tag{3}$$

where:

- $I_h = 2.9 \mu A$
- $I_P = 0.7 \mu A$
- $V_{ENRISING} = 1.25 V$
- $V_{ENFALLING} = 1.18 V$

## SLOW START / TRACKING PIN

The TPS54519 regulates to the lower of the SS/TR pin and the internal reference voltage. A capacitor on the SS/TR pin to ground implements a slow start time. The TPS54519 has an internal pull-up current source of 2.4µA which charges the external slow start capacitor. Equation 4 calculates the required slow start capacitor value where Tss is the desired slow start time in ms, Iss is the internal slow start charging current of 2.4 µA, and Vref is the internal voltage reference of 0.6 V.

$$C_{ss}(nF) = \frac{T_{ss}(mS) \times I_{ss}(\mu A)}{V_{ref}(V)} \quad (4)$$

If during normal operation, the VIN goes below the UVLO, EN pin pulled below 1.18 V, or a thermal shutdown event occurs, the TPS54519 stops switching and the SS/TR is discharged to 0 volts before reinitiating a powering up sequence.

## SEQUENCING

Many of the common power supply sequencing methods can be implemented using the SS/TR, EN and PWRGD pins. The sequential method can be implemented using an open drain or collector output of a power on reset pin of another device. Figure 18 shows the sequential method. The power good is coupled to the EN pin on the TPS54519 which enables the second power supply once the primary supply reaches regulation.

Ratio-metric start up can be accomplished by connecting the SS/TR pins together. The regulator outputs ramp up and reach regulation at the same time. When calculating the slow start time the pull up current source must be doubled in Equation 4. The ratio metric method is illustrated in Figure 20.

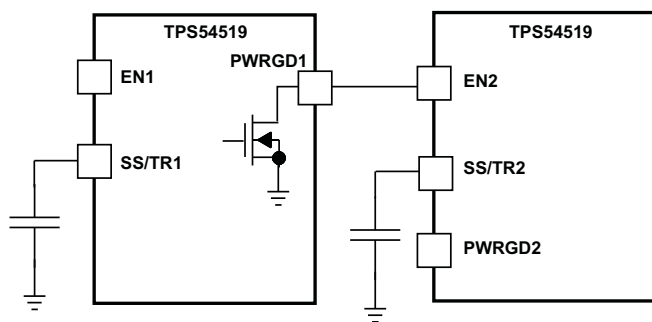

Figure 18. Sequential Start-Up Sequence

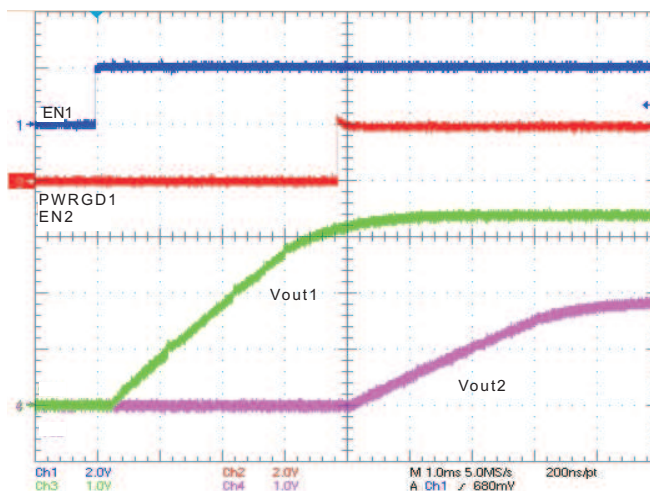

Figure 19. Sequential Startup using EN and PWRGD

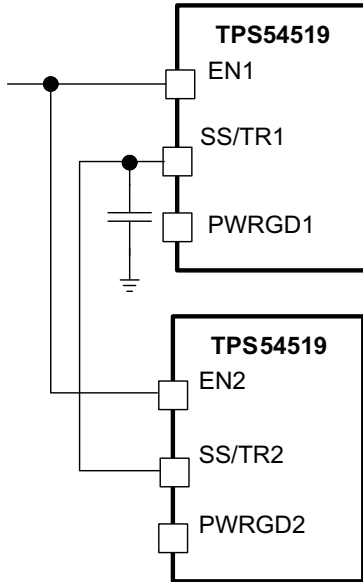

Figure 20. Schematic for Ratio-metric Startup Sequence

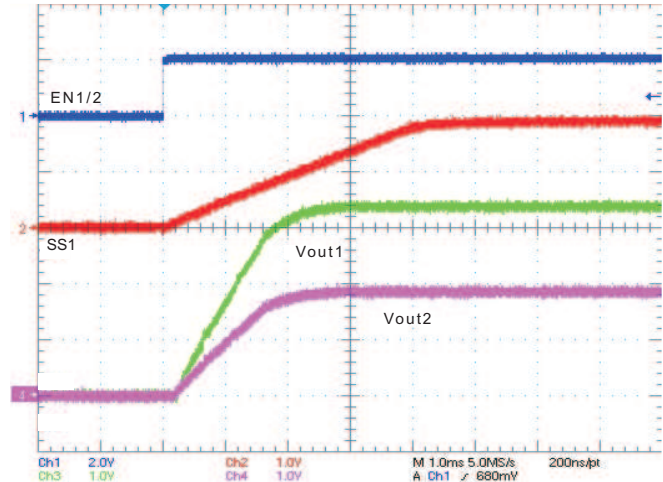

Figure 21. Ratio-metric Startup with Vout1 Leading Vout2

Ratio-metric and simultaneous power supply sequencing can be implemented by connecting the resistor network of R1 and R2 shown in Figure 22 to the output of the power supply that needs to be tracked or another voltage reference source. Using Equation 5 and Equation 6, the tracking resistors can be calculated to initiate the Vout2 slightly before, after or at the same time as Vout1. Equation 7 is the voltage difference between Vout1 and Vout2. The  $\Delta V$  variable is zero volts for simultaneous sequencing. To minimize the effect of the inherent SS/TR to VSENSE offset ( $V_{ssoffset}$ ) in the slow start circuit and the offset created by the pullup current source ( $I_{ss}$ ) and tracking resistors, the  $V_{ssoffset}$  and  $I_{ss}$  are included as variables in the equations. To design a ratio-metric start up in which the Vout2 voltage is slightly greater than the Vout1 voltage when Vout2 reaches regulation, use a negative number in Equation 5 through Equation 7 for  $\Delta V$ . Equation 7 will result in a positive number for applications which the Vout2 is slightly lower than Vout1 when Vout2 regulation is achieved. Since the SS/TR pin must be pulled below 40mV before starting after an EN, UVLO or thermal shutdown fault, careful selection of the tracking resistors is needed to ensure the device will restart after a fault. Make sure the calculated R1 value from Equation 5 is greater than the value calculated in Equation 8 to ensure the device can recover from a fault. As the SS/TR voltage becomes more than 85% of the nominal reference voltage the  $V_{ssoffset}$  becomes larger as the slow start circuits gradually handoff the regulation reference to the internal voltage reference. The SS/TR pin voltage needs to be greater than 0.87 V for a complete handoff to the internal voltage reference as shown in Figure 21.

$$R1 = \frac{V_{out2} + \Delta V}{V_{ref}} \times \frac{V_{ssoffset}}{I_{ss}} \tag{5}$$

$$R2 = \frac{V_{ref} \times R1}{V_{out2} + \Delta V - V_{ref}} \tag{6}$$

$$\Delta V = V_{out1} - V_{out2} \tag{7}$$

$$R1 > 2930 \times V_{out1} - 145 \times \Delta V \tag{8}$$

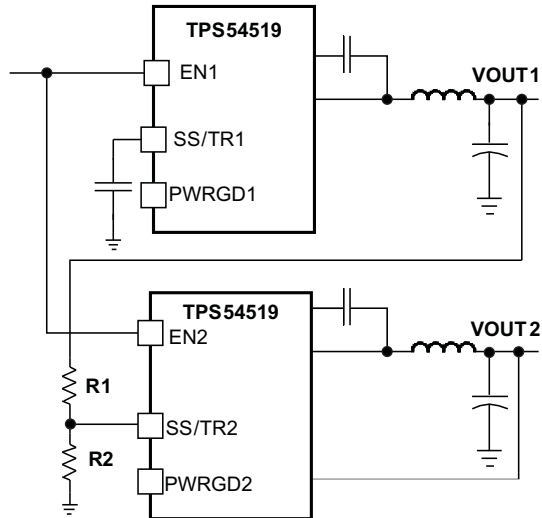

Figure 22. Schematic for Ratio-metric Start-Up Sequence

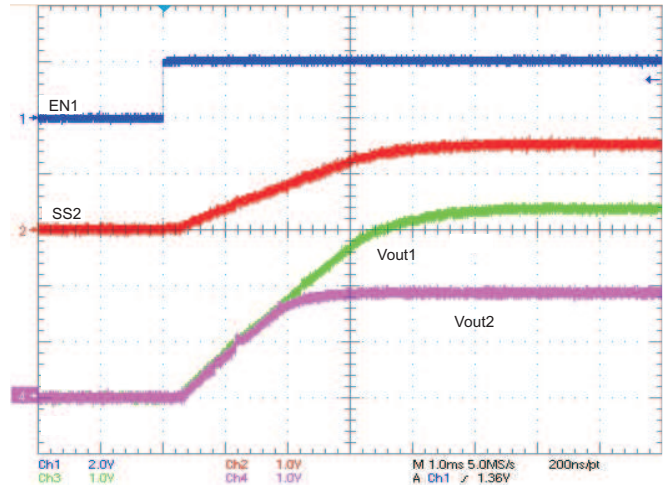

Figure 23. Ratio-metric Start-Up using Coupled SS/TR Pins

### CONSTANT SWITCHING FREQUENCY and TIMING RESISTOR (RT Pin)

The switching frequency of the TPS54519 is adjustable over a wide range from 200 kHz to 2000 kHz by placing a maximum of 218 kΩ and minimum of 16.9 kΩ, respectively, on the RT pin. An internal amplifier holds this pin at a fixed voltage when using an external resistor to ground to set the switching frequency. The RT is typically 0.5 V. To determine the timing resistance for a given switching frequency, use the curve in [Figure 8](#) and [Figure 9](#), or [Equation 9](#).

$$RT \text{ (k}\Omega\text{)} = 84145 \times F_{SW} \text{ (kHz)}^{-1.121} \quad (9)$$

$$F_{sw} \text{ (kHz)} = 24517 \times RT \text{ (k}\Omega\text{)}^{-0.89} \quad (10)$$

To reduce the solution size one would typically set the switching frequency as high as possible, but tradeoffs of the efficiency, maximum input voltage and minimum controllable on time should be considered.

The minimum controllable on time is typically 60 ns at full current load and 100 ns at no load, and limits the maximum operating input voltage or output voltage.

### OVERCURRENT PROTECTION

The TPS54519 implements a cycle by cycle current limit. During each switching cycle the high side switch current is compared to the voltage on the COMP pin. When the instantaneous switch current intersects the COMP voltage, the high side switch is turned off. During overcurrent conditions that pull the output voltage low, the error amplifier responds by driving the COMP pin high, increasing the switch current. The error amplifier output is clamped internally. This clamp functions as a switch current limit.

### FREQUENCY SHIFT

To operate at high switching frequencies and provide protection during overcurrent conditions, the TPS54519 implements a frequency shift. If frequency shift was not implemented, during an overcurrent condition the low side MOSFET may not be turned off long enough to reduce the current in the inductor, causing a current runaway. With frequency shift, during an overcurrent condition the switching frequency is reduced from 100%, then 50%, then 25% as the voltage decreases from 0.6 to 0 volts on VSENSE pin to allow the low side MOSFET to be off long enough to decrease the current in the inductor. During start-up, the switching frequency increases as the voltage on VSENSE increases from 0 to 0.6 volts. See [Figure 7](#) for details.

## REVERSE OVERCURRENT PROTECTION

The TPS54519 implements low side current protection by detecting the voltage across the low side MOSFET. When the converter sinks current through its low side FET, the control circuit turns off the low side MOSFET if the reverse current is more than 2.7 A. By implementing this additional protection scheme, the converter is able to protect itself from excessive current during power cycling and start-up into pre-biased outputs.

## POWER GOOD (PWRGD PIN)

The PWRGD pin output is an open drain MOSFET. The output is pulled low when the VSENSE voltage enters the fault condition by falling below 91% or rising above 107% of the nominal internal reference voltage. There is a 2% hysteresis on the threshold voltage, so when the VSENSE voltage rises to the good condition above 93% or falls below 105% of the internal voltage reference the PWRGD output MOSFET is turned off. It is recommended to use a pull-up resistor between the values of 1k $\Omega$  and 100k $\Omega$  to a voltage source that is 6 V or less. The PWRGD is in a valid state once the VIN input voltage is greater than 0.8 V, typically.

## OVERVOLTAGE TRANSIENT PROTECTION

The TPS54519 incorporates an overvoltage transient protection (OVTP) circuit to minimize voltage overshoot when recovering from output fault conditions or strong unload transients. The OVTP feature minimizes the output overshoot by implementing a circuit to compare the VSENSE pin voltage to the OVTP threshold which is 109% of the internal voltage reference. If the VSENSE pin voltage is greater than the OVTP threshold, the high side MOSFET is disabled preventing current from flowing to the output and minimizing output overshoot. When the VSENSE voltage drops lower than the OVTP threshold the high side MOSFET is allowed to turn on the next clock cycle.

## THERMAL SHUTDOWN

The device implements an internal thermal shutdown to protect itself if the junction temperature exceeds 155°C. The thermal shutdown forces the device to stop switching when the junction temperature exceeds the thermal trip threshold. Once the die temperature decreases below 155°C, the device reinitiates the power up sequence by discharging the SS/TR pin to 0 volts. The thermal shutdown hysteresis is 7.5°C.

## SMALL SIGNAL MODEL FOR LOOP RESPONSE

Figure 24 shows an equivalent model for the TPS54519 control loop which can be modeled in a circuit simulation program to check frequency response and dynamic load response. The error amplifier is a transconductance amplifier with a  $g_m$  of 250  $\mu\text{A}/\text{V}$ . The error amplifier can be modeled using an ideal voltage controlled current source. The resistor  $R_o$  and capacitor  $C_o$  model the open loop gain and frequency response of the amplifier. The 1-mV AC voltage source between the nodes a and b effectively breaks the control loop for the frequency response measurements. Plotting a/c shows the small signal response of the frequency compensation. Plotting a/b shows the small signal response of the overall loop. The dynamic loop response can be checked by replacing the  $R_L$  with a current source with the appropriate load step amplitude and step rate in a time domain analysis.

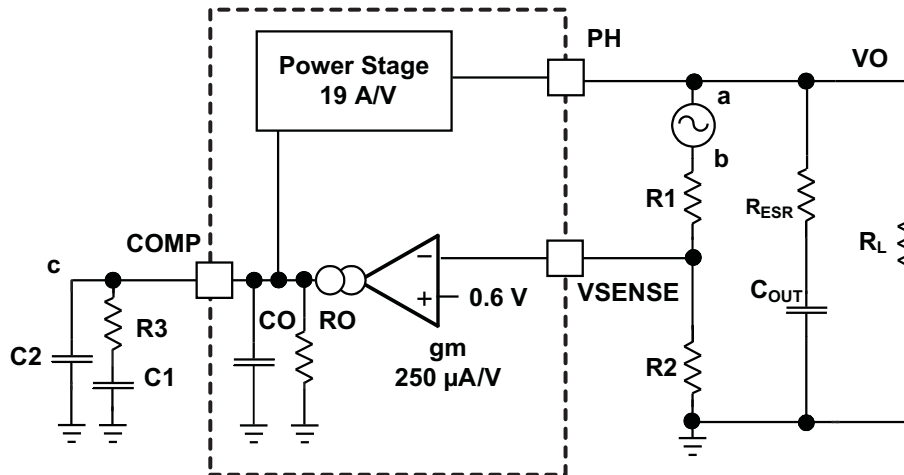

Figure 24. Small Signal Model for Loop Response

### SIMPLE SMALL SIGNAL MODEL FOR PEAK CURRENT MODE CONTROL

Figure 24 is a simple small signal model that can be used to understand how to design the frequency compensation. The TPS54519 power stage can be approximated to a voltage controlled current source (duty cycle modulator) supplying current to the output capacitor and load resistor. The control to output transfer function is shown in Equation 11 and consists of a dc gain, one dominant pole and one ESR zero. The quotient of the change in switch current and the change in COMP pin voltage (node c in Figure 24) is the power stage transconductance. The  $g_m$  for the TPS54519 is 19 A/V. The low frequency gain of the power stage frequency response is the product of the transconductance and the load resistance as shown in Equation 12. As the load current increases and decreases, the low frequency gain decreases and increases, respectively. This variation with load may seem problematic at first glance, but the dominant pole moves with load current [see Equation 13]. The combined effect is highlighted by the dashed line in the right half of Figure 25. As the load current decreases, the gain increases and the pole frequency lowers, keeping the 0-dB crossover frequency the same for the varying load conditions which makes it easier to design the frequency compensation.

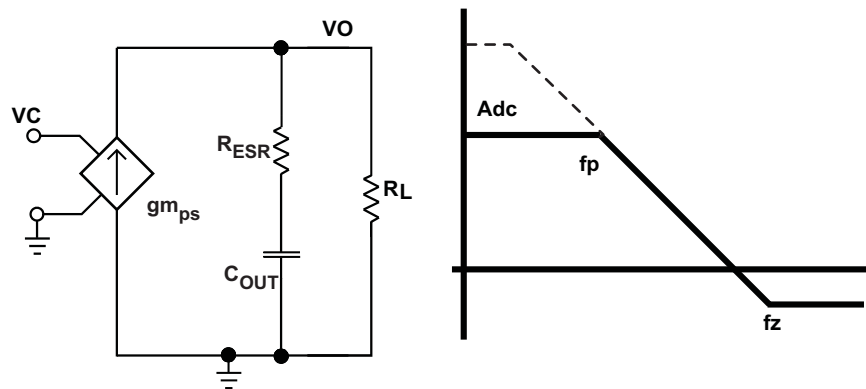

Figure 25. Simple Small Signal Model and Frequency Response for Peak Current Mode Control

$$\frac{v_o}{v_c} = A_{dc} \times \frac{\left(1 + \frac{s}{2\pi \times f_z}\right)}{\left(1 + \frac{s}{2\pi \times f_p}\right)} \quad (11)$$

$$A_{dc} = g_{m_{ps}} \times R_L \quad (12)$$

$$f_p = \frac{1}{C_{OUT} \times R_L \times 2\pi} \tag{13}$$

$$f_z = \frac{1}{C_{OUT} \times R_{ESR} \times 2\pi} \tag{14}$$

**SMALL SIGNAL MODEL FOR FREQUENCY COMPENSATION**

The TPS54519 uses a transconductance amplifier for the error amplifier and readily supports two of the commonly used frequency compensation circuits. The compensation circuits are shown in Figure 26. The Type 2 circuits are most likely implemented in high bandwidth power supply designs using low ESR output capacitors. In Type 2A, one additional high frequency pole is added to attenuate high frequency noise.

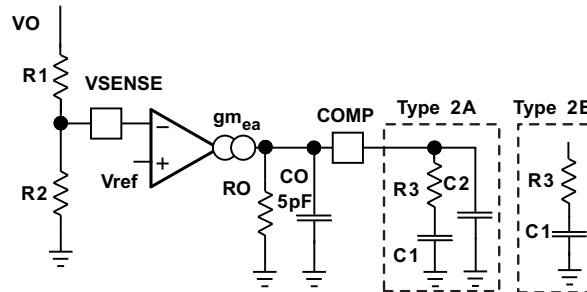

Figure 26. Types of Frequency Compensation

The design guidelines for TPS54519 loop compensation are as follows:

1. The modulator pole,  $f_{p\text{mod}}$ , and the esr zero,  $f_{z1}$  must be calculated using Equation 15 and Equation 16. Derating the output capacitor ( $C_{OUT}$ ) may be needed if the output voltage is a high percentage of the capacitor rating. Use the capacitor manufacturer information to derate the capacitor value. Use Equation 17 and Equation 18 to estimate a starting point for the crossover frequency,  $f_c$ . Equation 17 is the geometric mean of the modulator pole and the esr zero and Equation 18 is the mean of modulator pole and the switching frequency. Use the lower value of Equation 17 or Equation 18 as the maximum crossover frequency.

$$f_{p\text{ mod}} = \frac{I_{out\text{ max}}}{2\pi \times V_{out} \times C_{out}} \tag{15}$$

$$f_{z\text{ mod}} = \frac{1}{2\pi \times R_{esr} \times C_{out}} \tag{16}$$

$$f_c = \sqrt{f_{p\text{ mod}} \times f_{z\text{ mod}}} \tag{17}$$

$$f_c = \sqrt{f_{p\text{ mod}} \times \frac{f_{sw}}{2}} \tag{18}$$

2.  $R_3$  can be determined by

$$R_3 = \frac{2\pi \times f_c \times V_o \times C_{OUT}}{g_{m_{ea}} \times V_{ref} \times g_{m_{ps}}} \tag{19}$$

Where  $g_{m_{ea}}$  is the amplifier gain (250  $\mu\text{A/V}$ ),  $g_{m_{ps}}$  is the power stage gain (19  $\text{A/V}$ ).

3. Place a compensation zero at the dominant pole  $f_p = \frac{1}{C_{OUT} \times R_L \times 2\pi}$ .  $C_1$  can be determined by

$$C_1 = \frac{R_L \times C_{OUT}}{R_3} \tag{20}$$

4.  $C_2$  is optional. It can be used to cancel the zero from  $C_o$ 's ESR.

$$C_2 = \frac{R_{esr} \times C_{OUT}}{R_3} \tag{21}$$

## APPLICATION INFORMATION

### DESIGN GUIDE – STEP-BY-STEP DESIGN PROCEDURE

This example details the design of a high frequency switching regulator design using ceramic output capacitors. This design is available as the PWR037-002 evaluation module (EVM). A few parameters must be known in order to start the design process. These parameters are typically determined on the system level. For this example, we start with the following known parameters:

Output Voltage	1.8 V
Transient Response 1.25 to 3.75 A load step	$\Delta V_{out} = 4\%$
Maximum Output Current	5 A
Input Voltage	3 V - 6 V
Output Voltage Ripple	< 30 mV p-p
Start Input Voltage (rising VIN)	2.9 V
Stop Input Voltage (falling VIN)	2.66 V
Switching Frequency (Fsw)	1000 kHz

### SELECTING THE SWITCHING FREQUENCY

The first step is to decide on a switching frequency for the regulator. Typically, you want to choose the highest switching frequency possible since this produces the smallest solution size. The high switching frequency allows for lower valued inductors and smaller output capacitors compared to a power supply that switches at a lower frequency. However, the highest switching frequency causes extra switching losses, which hurt the converter's performance. The converter is capable of running from 200 kHz to 2 MHz. Unless a small solution size is an ultimate goal, a moderate switching frequency of 1MHz is selected to achieve both a small solution size and a high efficiency operation. Using Equation 9, R4 is calculated to be 35.4 k $\Omega$ . A standard 1% 35.7 k $\Omega$  value was chosen in the design.

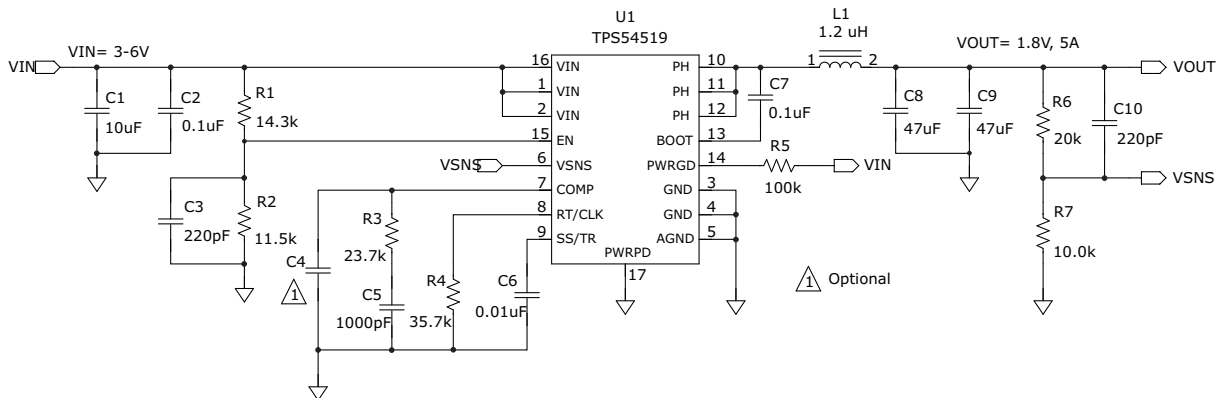

Figure 27. High Frequency, 1.8 V Output Power Supply Design with Adjusted UVLO

### OUTPUT INDUCTOR SELECTION

The inductor selected works for the entire TPS54519 input voltage range. To calculate the value of the output inductor, use Equation 22.  $K_{IND}$  is a coefficient that represents the amount of inductor ripple current relative to the maximum output current. The inductor ripple current is filtered by the output capacitor. Therefore, choosing high inductor ripple currents impacts the selection of the output capacitor since the output capacitor must have a ripple current rating equal to or greater than the inductor ripple current. In general, the inductor ripple value is at the discretion of the designer; however,  $K_{IND}$  is normally from 0.1 to 0.3 for the majority of applications.

For this design example, use  $K_{IND} = 0.3$  and the minimum inductor value is calculated to be 0.84  $\mu\text{H}$ . For this design, a larger standard value was chosen: 1.2  $\mu\text{H}$ . For the output filter inductor, it is important that the RMS current and saturation current ratings not be exceeded. The RMS and peak inductor current can be found from Equation 24 and Equation 25.

For this design, the RMS inductor current is 5.009 A and the peak inductor current is 5.525 A. The chosen inductor is a Coilcraft XAL5030-122ME. It has a saturation current rating of 11.8 A (20% inductance loss) and an RMS current rating of 8.7 A (20 °C temperature rise). The series resistance is 6,78 mΩ typical.

The current flowing through the inductor is the inductor ripple current plus the output current. During power up, faults or transient load conditions, the inductor current can increase above the calculated peak inductor current level calculated above. In transient conditions, the inductor current can increase up to the switch current limit of the device. For this reason, the most conservative approach is to specify an inductor with a saturation current rating equal to or greater than the switch current limit rather than the peak inductor current.

$$L1 = \frac{V_{inmax} - V_{out}}{I_o \times K_{ind}} \times \frac{V_{out}}{V_{inmax} \times f_{sw}} \quad (22)$$

$$I_{ripple} = \frac{V_{inmax} - V_{out}}{L1} \times \frac{V_{out}}{V_{inmax} \times f_{sw}} \quad (23)$$

$$I_{Lrms} = \sqrt{I_o^2 + \frac{1}{12} \times \left( \frac{V_o \times (V_{inmax} - V_o)}{V_{inmax} \times L1 \times f_{sw}} \right)^2} \quad (24)$$

$$I_{Lpeak} = I_{out} + \frac{I_{ripple}}{2} \quad (25)$$

## OUTPUT CAPACITOR

There are three primary considerations for selecting the value of the output capacitor. The output capacitor determines the modulator pole, the output voltage ripple, and how the regulator responds to a large change in load current. The output capacitance needs to be selected based on the more stringent of these three criteria.

The desired response to a large change in the load current is the first criteria. The output capacitor needs to supply the load with current when the regulator can not. This situation would occur if there are desired hold-up times for the regulator where the output capacitor must hold the output voltage above a certain level for a specified amount of time after the input power is removed. The regulator is temporarily not able to supply sufficient output current if there is a large, fast increase in the current needs of the load such as transitioning from no load to a full load. The regulator usually needs two or more clock cycles for the control loop to see the change in load current and output voltage and adjust the duty cycle to react to the change. The output capacitor must be sized to supply the extra current to the load until the control loop responds to the load change. The output capacitance must be large enough to supply the difference in current for 2 clock cycles while only allowing a tolerable amount of droop in the output voltage. Equation 26 shows the minimum output capacitance necessary to accomplish this.

For this example, the transient load response is specified as a 4% change in  $V_{out}$  for a load step from 1.25 A (25% load) to 3.75 A (75%). For this example,  $\Delta I_{out} = 3.75 - 1.25 = 2.5$  A and  $\Delta V_{out} = 0.04 \times 1.8 = 0.072$  V. Using these numbers gives a minimum capacitance of 69.4 μF. This value does not take the ESR of the output capacitor into account in the output voltage change. For ceramic capacitors, the ESR is usually small enough to ignore in this calculation.

Equation 27 calculates the minimum output capacitance needed to meet the output voltage ripple specification. Where  $f_{sw}$  is the switching frequency,  $V_{ripple}$  is the maximum allowable output voltage ripple, and  $I_{ripple}$  is the inductor ripple current. In this case, the maximum output voltage ripple is 30 mV. Under this requirement, Equation 27 yields 4.38μF.

$$C_o > \frac{2 \times \Delta I_{out}}{f_{sw} \times \Delta V_{out}} \quad (26)$$

$$C_o > \frac{1}{8 \times f_{sw}} \times \frac{1}{\frac{V_{ripple}}{I_{ripple}}}$$

Where  $\Delta I_{out}$  is the change in output current,  $f_{sw}$  is the regulators switching frequency and  $\Delta V_{out}$  is the allowable change in the output voltage. (27)

[Equation 28](#) calculates the maximum ESR an output capacitor can have to meet the output voltage ripple specification. [Equation 28](#) indicates the ESR should be less than 28.6 mΩ. In this case, the ESR of the ceramic capacitor is much less than 28.6 mΩ.

Additional capacitance de-ratings for aging, temperature and DC bias should be factored in which increases this minimum value. For this example, two 47 μF 10 V X5R ceramic capacitors with 3 mΩ of ESR are used.

Capacitors generally have limits to the amount of ripple current they can handle without failing or producing excess heat. An output capacitor that can support the inductor ripple current must be specified. Some capacitor data sheets specify the RMS (Root Mean Square) value of the maximum ripple current. [Equation 29](#) can be used to calculate the RMS ripple current the output capacitor needs to support. For this application, [Equation 29](#) yields 303 mA.

$$\text{Resr} < \frac{V_{\text{ripple}}}{I_{\text{ripple}}} \quad (28)$$

$$I_{\text{corms}} = \frac{V_{\text{out}} \times (V_{\text{inmax}} - V_{\text{out}})}{\sqrt{12} \times V_{\text{inmax}} \times L1 \times f_{\text{sw}}} \quad (29)$$

## INPUT CAPACITOR

The TPS54519 requires a high quality ceramic, type X5R or X7R, input decoupling capacitor of at least 4.7 μF of effective capacitance and in some applications a bulk capacitance. The effective capacitance includes any DC bias effects. The voltage rating of the input capacitor must be greater than the maximum input voltage. The capacitor must also have a ripple current rating greater than the maximum input current ripple of the TPS54519. The input ripple current can be calculated using [Equation 30](#).

The value of a ceramic capacitor varies significantly over temperature and the amount of DC bias applied to the capacitor. The capacitance variations due to temperature can be minimized by selecting a dielectric material that is stable over temperature. X5R and X7R ceramic dielectrics are usually selected for power regulator capacitors because they have a high capacitance to volume ratio and are fairly stable over temperature. The output capacitor must also be selected with the DC bias taken into account. The capacitance value of a capacitor decreases as the DC bias across a capacitor increases.

For this example design, a ceramic capacitor with at least a 10 V voltage rating is required to support the maximum input voltage. For this example, one 10 μF and one 0.1 μF 10 V capacitors in parallel have been selected. The input capacitance value determines the input ripple voltage of the regulator. The input voltage ripple can be calculated using [Equation 31](#). Using the design example values,  $I_{\text{outmax}}=4$  A,  $C_{\text{in}}=10$  μF,  $f_{\text{sw}}=1$  MHz, yields an input voltage ripple of 124 mV and a rms input ripple current of 2.45 A.

$$I_{\text{cirms}} = I_{\text{out}} \times \sqrt{\frac{V_{\text{out}}}{V_{\text{inmin}}} \times \frac{(V_{\text{inmin}} - V_{\text{out}})}{V_{\text{inmin}}}} \quad (30)$$

$$\Delta V_{\text{in}} = \frac{I_{\text{outmax}} \times 0.25}{C_{\text{in}} \times f_{\text{sw}}} \quad (31)$$

## SLOW START CAPACITOR

The slow start capacitor determines the minimum amount of time it takes for the output voltage to reach its nominal programmed value during power up. This is useful if a load requires a controlled voltage slew rate. This is also used if the output capacitance is very large and would require large amounts of current to quickly charge the capacitor to the output voltage level. The large currents necessary to charge the capacitor may make the TPS54519 reach the current limit or excessive current draw from the input power supply may cause the input voltage rail to sag. Limiting the output voltage slew rate solves both of these problems.

The slow start capacitor value can be calculated using [Equation 4](#). For the example circuit, the slow start time is not too critical since the output capacitor value is 2 x 47μF which does not require much current to charge to 1.8 V. The example circuit has the slow start time set to an arbitrary value of 2.5 ms which requires a 10 nF capacitor. In TPS54519,  $I_{\text{ss}}$  is 2.4 μA and  $V_{\text{ref}}$  is 0.6 V.

## BOOTSTRAP CAPACITOR SELECTION

A 0.1  $\mu\text{F}$  ceramic capacitor must be connected between the BOOT to PH pin for proper operation. It is recommended to use a ceramic capacitor with X5R or better grade dielectric. The capacitor should have 10 V or higher voltage rating.

## UNDER VOLTAGE LOCK OUT SET POINT

The Under Voltage Lock Out (UVLO) can be adjusted using an external voltage divider on the EN pin of the TPS54519. The UVLO has two thresholds, one for power up when the input voltage is rising and one for power down or brown outs when the input voltage is falling. For the example design, the supply should turn on and start switching once the input voltage increases above 2.794 V ( $V_{\text{START}}$ ). After the regulator starts switching, it should continue to do so until the input voltage falls below 2.595 V ( $V_{\text{STOP}}$ ).

The programmable UVLO and enable voltages are set using a resistor divider between  $V_{\text{in}}$  and ground to the EN pin. [Equation 2](#) and [Equation 3](#) can be used to calculate the resistance values necessary. From [Equation 2](#) and [Equation 3](#), a 14.3 k $\Omega$  between  $V_{\text{in}}$  and EN and a 11.5 k $\Omega$  between EN and ground are required to produce the 2.794 and 2.595 volt start and stop voltages.

## OUTPUT VOLTAGE AND FEEDBACK RESISTORS SELECTION

For the example design, 100 k $\Omega$  was selected for R6. Using [Equation 32](#), R7 is calculated as 80 k $\Omega$ . The nearest standard 1% resistor is 80.5 k $\Omega$ .

$$R7 = \frac{V_{\text{ref}}}{V_{\text{o}} - V_{\text{ref}}} R6 \quad (32)$$

Due to the internal design of the TPS54519, there is a minimum output voltage limit for any given input voltage. The output voltage can never be lower than the internal voltage reference of 0.6 V. Above 0.6 V, the output voltage may be limited by the minimum controllable on time. The minimum output voltage in this case is given by [Equation 33](#)

$$V_{\text{outmin}} = \left( \text{Ontimemin} \times F_{\text{smax}} \times \left( V_{\text{inmax}} - \left( I_{\text{outmin}} \times (2 \times R_{\text{DS}}) \right) \right) \right) - \left( I_{\text{outmin}} \times (R_{\text{L}} + R_{\text{DS}}) \right)$$

Where:

$V_{\text{outmin}}$  = minimum achievable output voltage

$\text{Ontimemin}$  = minimum controllable on-time (60 ns typical. 110 nsec no load)

$F_{\text{smax}}$  = maximum switching frequency including tolerance

$V_{\text{inmax}}$  = maximum input voltage

$I_{\text{outmin}}$  = minimum load current

$R_{\text{DS}}$  = minimum high side MOSFET on resistance (30 - 44 m $\Omega$ )

$R_{\text{L}}$  = series resistance of output inductor

(33)

There is also a maximum achievable output voltage which is limited by the minimum off time. The maximum output voltage is given by [Equation 34](#)

$$V_{outmax} = (1 - (Off_{time} \times F_{smax})) \times (V_{inmin} - (I_{outmax} \times (2 \times R_{DS}))) - I_{outmax} \times (R_L + R_{DS})$$

Where:

$V_{outmax}$  = maximum achievable output voltage

$Off_{time}$  = maximum off time (60 nsec typical)

$F_{smax}$  = maximum switching frequency including tolerance

$V_{inmin}$  = minimum input voltage

$I_{outmax}$  = maximum load current

$R_{DS}$  = maximum high side MOSFET on resistance (60 - 70 mΩ)

$R_L$  = series resistance of output inductor

(34)

## COMPENSATION

There are several possible methods to design closed loop compensation for dc/dc converters. For the ideal current mode control, the design equations can be easily simplified. The power stage gain is constant at low frequencies, and rolls off at -20 dB/decade above the modulator pole frequency. The power stage phase is 0 degrees at low frequencies and starts to fall one decade above the modulator pole frequency reaching a minimum of -90 degrees one decade above the modulator pole frequency. The modulator pole is a simple pole shown in [Equation 35](#)

$$f_{p \text{ mod}} = \frac{I_{outmax}}{2\pi \times V_{out} \times C_{out}} \quad (35)$$

For the TPS54519 most circuits will have relatively high amounts of slope compensation. As more slope compensation is applied, the power stage characteristics will deviate from the ideal approximations. The phase loss of the power stage will now approach -180 degrees, making compensation more difficult. The power stage transfer function can be solved but it is a tedious hand calculation that does not lend itself to simple approximations. It is best to use Pspice or TINA-TI to accurately model the power stage gain and phase so that a reliable compensation circuit can be designed. That is the technique used in this design procedure. Using the pspice model of ([insert link here](#)). Apply the values calculated previously to the output filter components of L1, C8 and C9. Set  $R_{load}$  to the appropriate value. For this design,  $L1 = 1.2 \mu\text{H}$ . C8 and C9 use the derated capacitance value of  $43 \mu\text{F}$ , and the ESR is set to 3 mohm. The  $R_{load}$  resistor is  $1.8 / 5 = 21.6 \text{ m}\Omega$ . Now the power stage characteristic can be plotted as shown in [Figure 28](#)

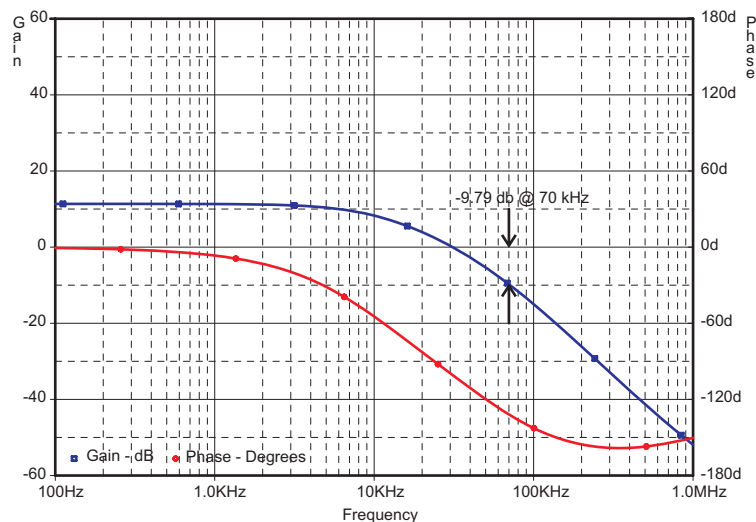

Figure 28. Power Stage Gain and Phase Characteristics

For this design, the intended crossover frequency is 70 kHz. From the power stage gain and phase plots, the gain at 70 kHz is -9.79 dB and the phase is -131.87 degrees. For 60 degrees of phase margin, additional phase boost from a feed forward capacitor in parallel with the upper resistor of the voltage set point divider will be required. R3 sets the gain of the compensated error amplifier to be equal and opposite the power stage gain at crossover. The required value of R3 can be calculated from [Equation 36](#).

$$R3 = \frac{10^{-\frac{G_{PWRSTG}}{20}}}{g_{mEA}} \cdot \sqrt{\frac{V_{out}}{V_{REF}}} \quad (36)$$

To maximize phase gain, the compensator zero is placed one decade below the crossover frequency of 70 kHz. The required value for C5 is given by [Equation 37](#).

$$C5 = \frac{1}{2 \cdot \pi \cdot R3 \cdot \frac{F_{CO}}{10}} \quad (37)$$

To maximize phase gain the high frequency pole is not implemented and C4 is not populated. The pole can be useful to offset the ESR of aluminum electrolytic output capacitors. If desired the value for C4 can be calculated from [Equation 38](#).

$$C4 = \frac{1}{2 \cdot \pi \cdot R3 \cdot F_P} \quad (38)$$

For maximum phase boost, the pole frequency  $F_P$  will typically be one decade above the intended crossover frequency  $F_{CO}$ .

The feed forward capacitor C10, is used to increase the phase boost at crossover above what is normally available from Type II compensation. It places an additional zero/pole pair located at [Equation 39](#) and [Equation 40](#).

$$F_Z = \frac{1}{2 \cdot \pi \cdot C10 \cdot R6} \quad (39)$$

$$F_P = \frac{1}{2 \cdot \pi \cdot C10 \cdot R6 \parallel R7} \quad (40)$$

This zero and pole pair is not independent. Once the zero location is chosen, the pole is fixed as well. For optimum performance, the zero and pole should be located symmetrically about the intended crossover frequency. The required value for C10 can be calculated from [Equation 41](#).

$$C10 = \frac{1}{2 \cdot \pi \cdot R6 \cdot F_{CO} \cdot \sqrt{\frac{V_{REF}}{V_{OUT}}}} \quad (41)$$

For this design the calculated values for the compensation components are  $R3 = 23.8 \text{ k}\Omega$ ,  $C5 = 959 \text{ pF}$  and  $C10 = 197 \text{ pF}$ . Using standard values, the compensation components are  $R3 = 23.7 \text{ k}\Omega$ ,  $C5 = 1000 \text{ pF}$  and  $C10 = 220 \text{ pF}$ .

## APPLICATION CURVES

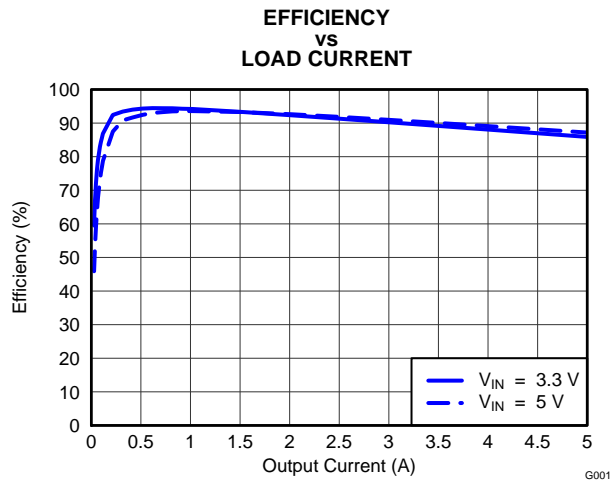

Figure 29.

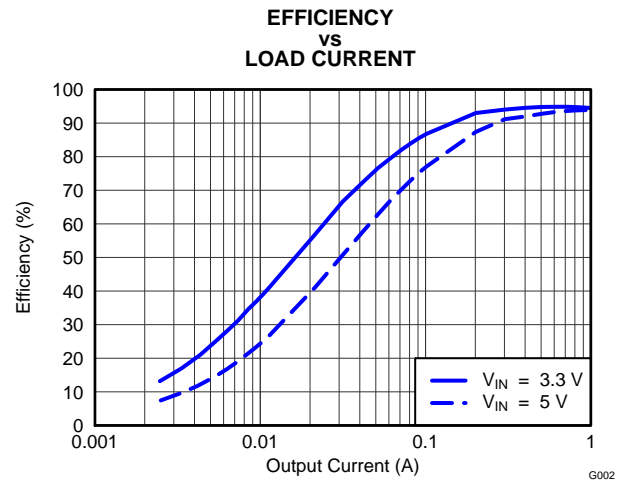

Figure 30.

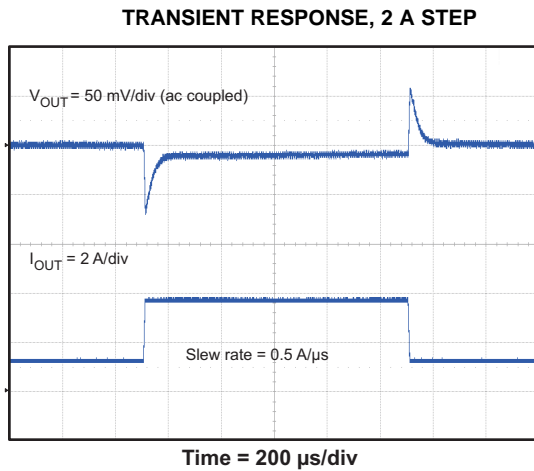

Figure 31.

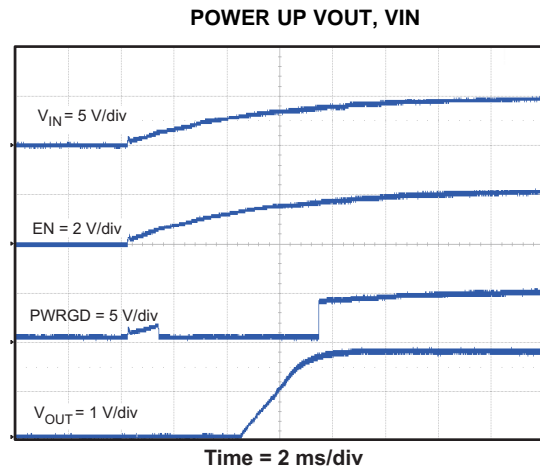

Figure 32.

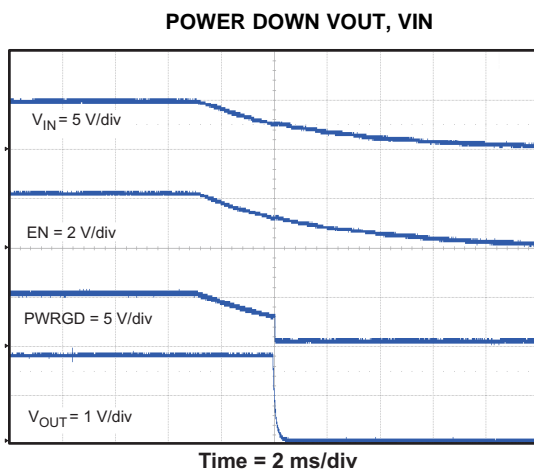

Figure 33.

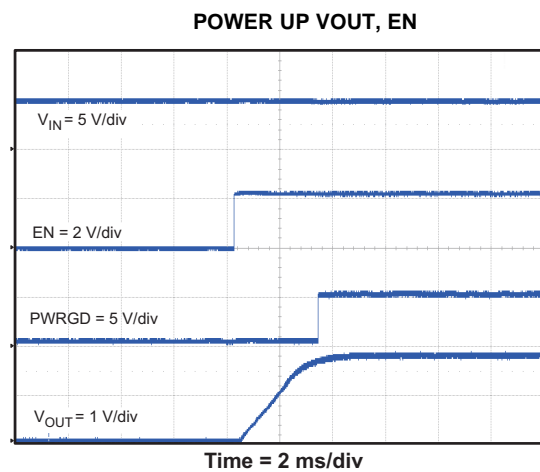
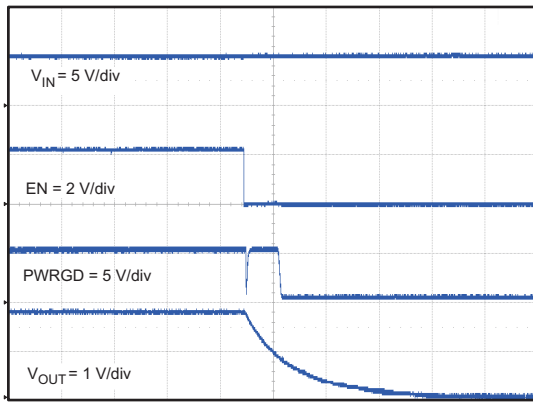

Figure 34.

**POWER DOWN VOUT, EN**



Time = 100  $\mu$ s/div

**Figure 35.**

**OUTPUT RIPPLE, 5 A**

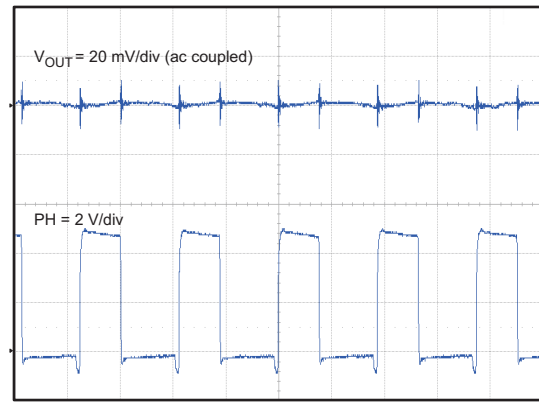

Time = 500 ns/div

**Figure 36.**

**INPUT RIPPLE, 5 A**

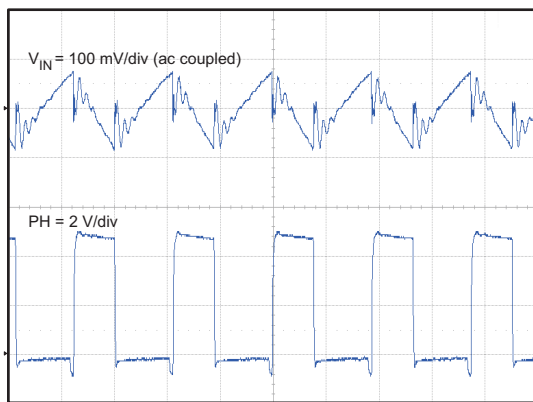

Time = 500 ns/div

**Figure 37.**

**CLOSED LOOP RESPONSE, VIN (3.3 V), 4 A**

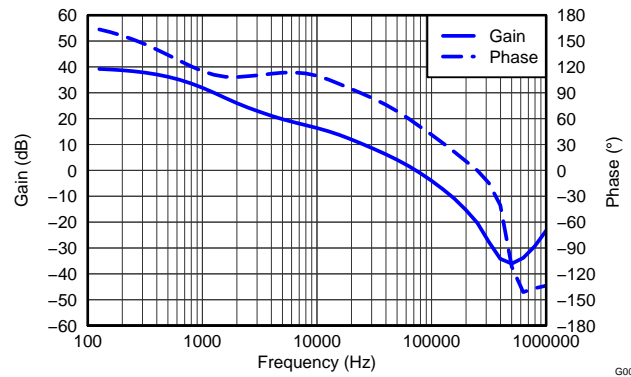

G005

**Figure 38.**

**LOAD REGULATION vs LOAD CURRENT**

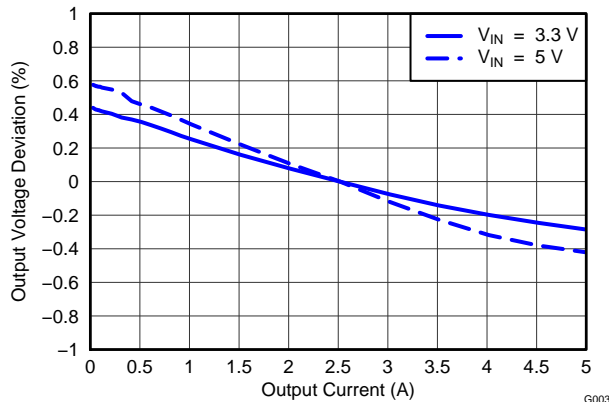

G003

**Figure 39.**

**REGULATION vs INPUT VOLTAGE**

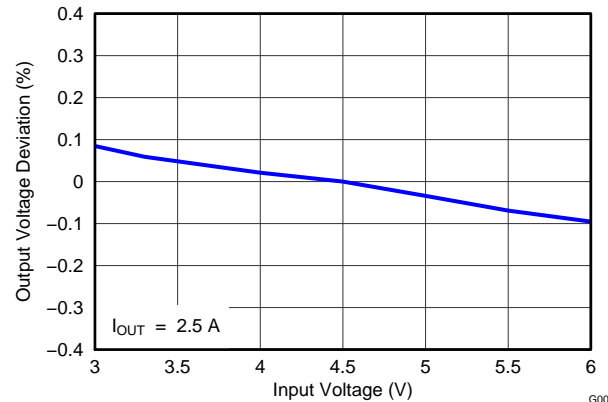

G004

**Figure 40.**

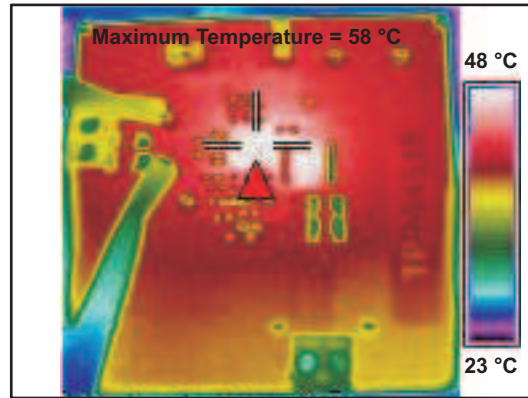

$I_{OUT} = 5\text{ A}$

Figure 41. Thermal Image

## POWER DISSIPATION ESTIMATE

The following formulas show how to estimate the IC power dissipation under continuous conduction mode (CCM) operation. The power dissipation of the IC ( $P_{tot}$ ) includes conduction loss ( $P_{con}$ ), dead time loss ( $P_d$ ), switching loss ( $P_{sw}$ ), gate drive loss ( $P_{gd}$ ) and supply current loss ( $P_q$ ).

$$P_{con} = I_{out}^2 \times R_{dson\_temp}$$

$$P_d = f_{sw} \times I_{out} \times 0.7 \times 40 \times 10^{-9}$$

$$P_{sw} = 0.5 \times V_{in} \times I_o \times f_{sw} \times 7 \times 10^{-9}$$

$$P_{gd} = 2 \times V_{in} \times 6 \times 10^{-9} \times f_{sw}$$

$$P_q = 455 \times 10^{-6} \times V_{in}$$

Where:

$I_{OUT}$  is the output current (A).

$R_{dson}$  is the on-resistance of the high-side MOSFET ( $\Omega$ ).

$V_{OUT}$  is the output voltage (V).

$V_{IN}$  is the input voltage (V).

$f_{sw}$  is the switching frequency (Hz).

So

$$P_{tot} = P_{con} + P_d + P_{sw} + P_{gd} + P_q$$

For given  $T_A$ ,

$$T_J = T_A + R_{th} \times P_{tot}$$

For given  $T_{JMAX} = 140^\circ\text{C}$

$$T_{Amax} = T_{Jmax} - R_{th} \times P_{tot}$$

Where:

$P_{tot}$  is the total device power dissipation (W).

$T_A$  is the ambient temperature ( $^\circ\text{C}$ ).

$T_J$  is the junction temperature ( $^\circ\text{C}$ ).

$R_{th}$  is the thermal resistance of the package ( $^\circ\text{C}/\text{W}$ ).

$T_{JMAX}$  is maximum junction temperature ( $^\circ\text{C}$ ).

$T_{AMAX}$  is maximum ambient temperature ( $^\circ\text{C}$ ).

There are additional power losses in the regulator circuit due to the inductor AC and DC losses and trace resistance that impact the overall efficiency of the regulator.

## LAYOUT

Layout is a critical portion of good power supply design. There are several signal paths that conduct fast changing currents or voltages that can interact with stray inductance or parasitic capacitance to generate noise or degrade the power supplies performance. Care should be taken to minimize the loop area formed by the bypass capacitor connections and the VIN pins. See [Figure 42](#) for a PCB layout example. The GND pins and AGND pin should be tied directly to the power pad under the IC. The power pad should be connected to any internal PCB ground planes using multiple vias directly under the IC. Additional vias can be used to connect the top side ground area to the internal planes near the input and output capacitors. For operation at full rated load, the top side ground area along with any additional internal ground planes must provide adequate heat dissipating area.

Locate the input bypass capacitor as close to the IC as possible. The PH pin should be routed to the output inductor. Since the PH connection is the switching node, the output inductor should be located very close to the PH pins, and the area of the PCB conductor minimized to prevent excessive capacitive coupling. The boot capacitor must also be located close to the device. The sensitive analog ground connections for the feedback voltage divider, compensation components, slow start capacitor and frequency set resistor should be connected to a separate analog ground trace as shown. The RT pin is particularly sensitive to noise so the RT resistor should be located as close as possible to the IC and routed with minimal lengths of trace. The additional external components can be placed approximately as shown. It may be possible to obtain acceptable performance with alternate PCB layouts, however this layout has been shown to produce good results and is meant as a guideline.

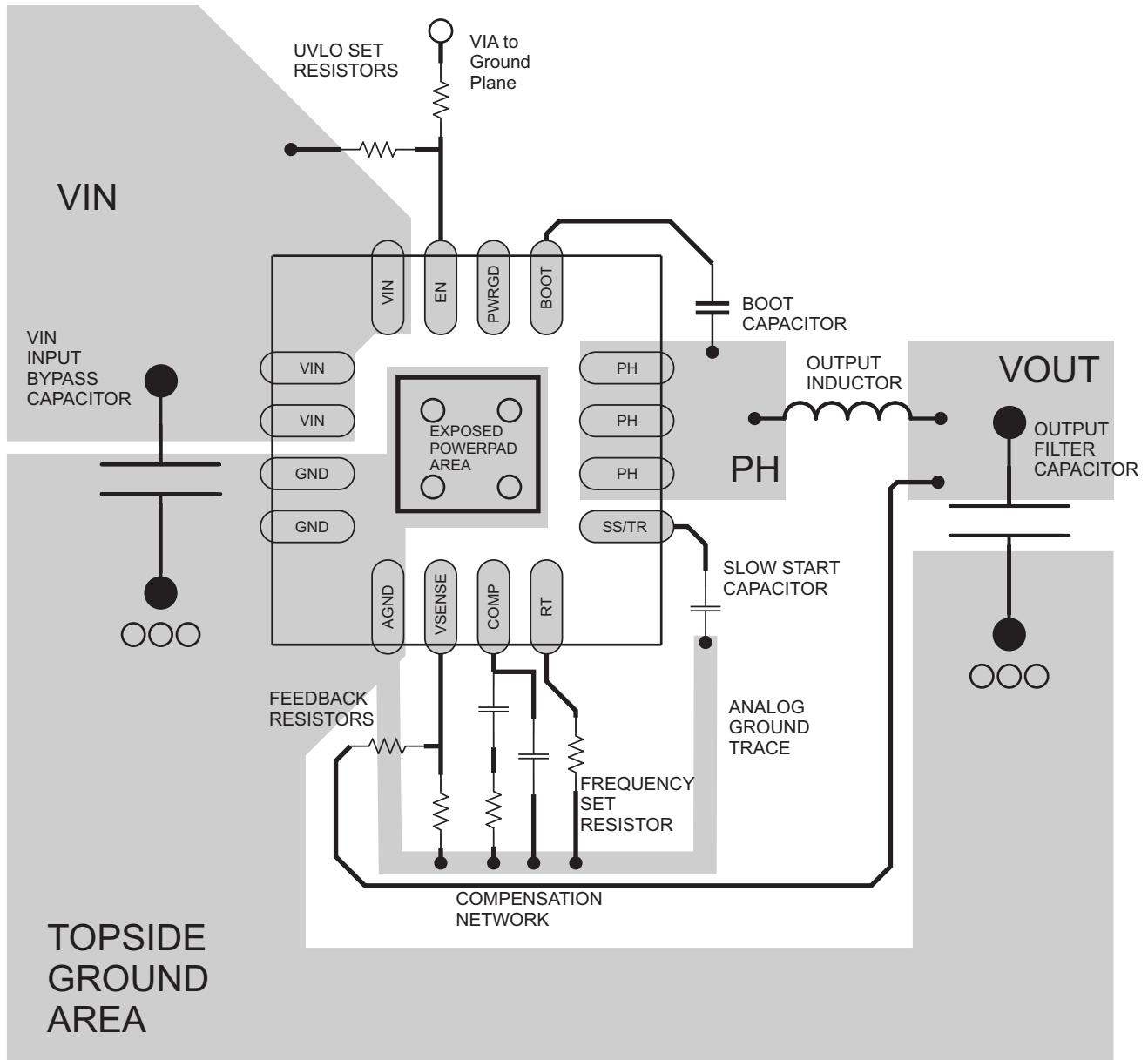

○ VIA to Ground Plane

Figure 42. PCB Layout Example

### REVISION HISTORY

NOTE: Page numbers of current revision may differ from previous versions.

Changes from Original (September 2011) to Revision A	Page
• Added Voltage Reference spec for Condition "0 A ≤ I <sub>OUT</sub> ≤ 5 A, 25°C " .....	3

**PACKAGING INFORMATION**

Orderable Device	Status (1)	Package Type	Package Drawing	Pins	Package Qty	Eco Plan (2)	Lead finish/ Ball material (6)	MSL Peak Temp (3)	Op Temp (°C)	Device Marking (4/5)	Samples
TPS54519RTER	ACTIVE	WQFN	RTE	16	3000	RoHS & Green	NIPDAU	Level-2-260C-1 YEAR	-40 to 140	54519	<a href="#">Samples</a>
TPS54519RTET	ACTIVE	WQFN	RTE	16	250	RoHS & Green	NIPDAU	Level-2-260C-1 YEAR	-40 to 140	54519	<a href="#">Samples</a>

(1) The marketing status values are defined as follows:

**ACTIVE:** Product device recommended for new designs.

**LIFEBUY:** TI has announced that the device will be discontinued, and a lifetime-buy period is in effect.

**NRND:** Not recommended for new designs. Device is in production to support existing customers, but TI does not recommend using this part in a new design.

**PREVIEW:** Device has been announced but is not in production. Samples may or may not be available.

**OBsolete:** TI has discontinued the production of the device.

(2) **RoHS:** TI defines "RoHS" to mean semiconductor products that are compliant with the current EU RoHS requirements for all 10 RoHS substances, including the requirement that RoHS substance do not exceed 0.1% by weight in homogeneous materials. Where designed to be soldered at high temperatures, "RoHS" products are suitable for use in specified lead-free processes. TI may reference these types of products as "Pb-Free".

**RoHS Exempt:** TI defines "RoHS Exempt" to mean products that contain lead but are compliant with EU RoHS pursuant to a specific EU RoHS exemption.

**Green:** TI defines "Green" to mean the content of Chlorine (Cl) and Bromine (Br) based flame retardants meet JS709B low halogen requirements of <=1000ppm threshold. Antimony trioxide based flame retardants must also meet the <=1000ppm threshold requirement.

(3) MSL, Peak Temp. - The Moisture Sensitivity Level rating according to the JEDEC industry standard classifications, and peak solder temperature.

(4) There may be additional marking, which relates to the logo, the lot trace code information, or the environmental category on the device.

(5) Multiple Device Markings will be inside parentheses. Only one Device Marking contained in parentheses and separated by a "~" will appear on a device. If a line is indented then it is a continuation of the previous line and the two combined represent the entire Device Marking for that device.

(6) Lead finish/Ball material - Orderable Devices may have multiple material finish options. Finish options are separated by a vertical ruled line. Lead finish/Ball material values may wrap to two lines if the finish value exceeds the maximum column width.

**Important Information and Disclaimer:**The information provided on this page represents TI's knowledge and belief as of the date that it is provided. TI bases its knowledge and belief on information provided by third parties, and makes no representation or warranty as to the accuracy of such information. Efforts are underway to better integrate information from third parties. TI has taken and continues to take reasonable steps to provide representative and accurate information but may not have conducted destructive testing or chemical analysis on incoming materials and chemicals. TI and TI suppliers consider certain information to be proprietary, and thus CAS numbers and other limited information may not be available for release.

In no event shall TI's liability arising out of such information exceed the total purchase price of the TI part(s) at issue in this document sold by TI to Customer on an annual basis.



**TAPE AND REEL INFORMATION**

**QUADRANT ASSIGNMENTS FOR PIN 1 ORIENTATION IN TAPE**

\*All dimensions are nominal

Device	Package Type	Package Drawing	Pins	SPQ	Reel Diameter (mm)	Reel Width W1 (mm)	A0 (mm)	B0 (mm)	K0 (mm)	P1 (mm)	W (mm)	Pin1 Quadrant
TPS54519RTER	WQFN	RTE	16	3000	330.0	12.4	3.3	3.3	1.1	8.0	12.0	Q2
TPS54519RTET	WQFN	RTE	16	250	180.0	12.4	3.3	3.3	1.1	8.0	12.0	Q2

**TAPE AND REEL BOX DIMENSIONS**

\*All dimensions are nominal

Device	Package Type	Package Drawing	Pins	SPQ	Length (mm)	Width (mm)	Height (mm)
TPS54519RTER	WQFN	RTE	16	3000	367.0	367.0	35.0
TPS54519RTET	WQFN	RTE	16	250	210.0	185.0	35.0

## GENERIC PACKAGE VIEW

**RTE 16**

**WQFN - 0.8 mm max height**

3 x 3, 0.5 mm pitch

PLASTIC QUAD FLATPACK - NO LEAD

This image is a representation of the package family, actual package may vary.  
Refer to the product data sheet for package details.

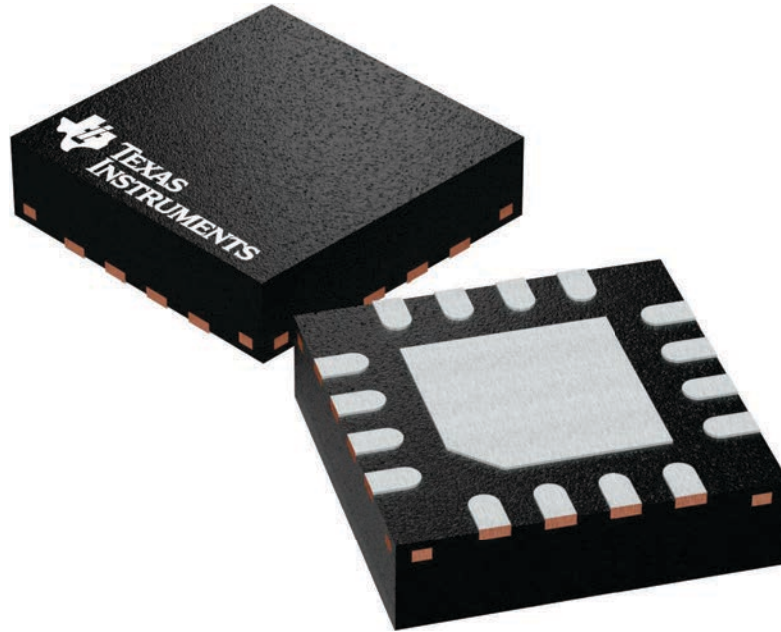

4225944/A

## 重要声明和免责声明

TI“按原样”提供技术和可靠性数据（包括数据表）、设计资源（包括参考设计）、应用或其他设计建议、网络工具、安全信息和其他资源，不保证没有瑕疵且不做任何明示或暗示的担保，包括但不限于对适销性、某特定用途方面的适用性或不侵犯任何第三方知识产权的暗示担保。

这些资源可供使用 TI 产品进行设计的熟练开发人员使用。您将自行承担以下全部责任：(1) 针对您的应用选择合适的 TI 产品，(2) 设计、验证并测试您的应用，(3) 确保您的应用满足相应标准以及任何其他功能安全、信息安全、监管或其他要求。

这些资源如有变更，恕不另行通知。TI 授权您仅可将这些资源用于研发本资源所述的 TI 产品的应用。严禁对这些资源进行其他复制或展示。您无权使用任何其他 TI 知识产权或任何第三方知识产权。您应全额赔偿因在这些资源的使用中对 TI 及其代表造成的任何索赔、损害、成本、损失和债务，TI 对此概不负责。

TI 提供的产品受 [TI 的销售条款](#) 或 [ti.com](#) 上其他适用条款/TI 产品随附的其他适用条款的约束。TI 提供这些资源并不会扩展或以其他方式更改 TI 针对 TI 产品发布的适用的担保或担保免责声明。

TI 反对并拒绝您可能提出的任何其他或不同的条款。

邮寄地址：Texas Instruments, Post Office Box 655303, Dallas, Texas 75265

Copyright © 2022，德州仪器 (TI) 公司