

# LM5175-Q1 42V 宽 $V_{IN}$ 同步 4 开关降压-升压控制器

## 1 特性

- 适用于汽车电子 应用
- 具有符合 AEC-Q100 标准的下列结果：
  - 器件温度 1 级：-40°C 至 +125°C 的环境运行温度范围
  - 器件人体模型 (HBM) 静电放电 (ESD) 分类等级 2
  - 器件组件充电模式 (CDM) ESD 分类等级 C4B
- 单电感降压-升压控制器，用于升压/降压 DC/DC 转换
- 宽  $V_{IN}$  范围：3.5V 至 42V，最大值为 60V
- 灵活的  $V_{OUT}$  范围：0.8V 至 55V
- $V_{OUT}$  短路保护
- 高效降压-升压转换
- 可调开关频率
- 可选频率同步和抖动
- 集成 2A 金属氧化物半导体场效应晶体管 (MOSFET) 栅极驱动器
- 逐周期电流限制和可选断续模式
- 可选输入或输出平均电流限制
- 可编程的输入欠压闭锁 (UVLO) 和软启动
- 电源正常和输出过压保护
- 可利用脉冲跳跃来选择连续导通模式 (CCM) 或断续导通模式 (DCM)
- 薄型小外形尺寸 (HTSSOP)-28 封装

## 2 应用

- 汽车起停系统
- 备用电池和超级电容充电
- 工业 PC 用电源
- USB 供电
- LED 照明

## 3 说明

LM5175-Q1 是一款同步四开关降压-升压 DC/DC 控制器，能够将输出电压稳定在输入电压、高于输入电压或者低于输入电压的某一电压值上。LM5175-Q1 可在 3.5V 至 42V 的宽输入电压范围内运行（最大值为 60V），支持各类应用。

LM5175-Q1 在降压和升压工作模式下均采用电流模式控制，以提供出色的负载和线路调节性能。开关频率可通过外部电阻进行编程，并且可与外部时钟信号同步。

该器件还具有可编程软启动功能，并且提供诸如逐周期电流限制、输入欠压锁定 (UVLO)、输出过压保护 (OVP) 和热关断等各类保护特性。此外，LM5175-Q1 特有可选择的连续导通模式 (CCM) 或断续导通模式 (DCM)、可选平均输入或输出电流限制、可降低峰值电磁干扰 (EMI) 的可选扩展频谱以及应对持续过载情况的可选断续模式保护。

### 器件信息<sup>(1)</sup>

订货编号	封装	封装尺寸
LM5175-Q1	HTSSOP-28	9.7mm x 4.4mm

(1) 要了解所有可用封装，请见数据表末尾的可订购产品附录。

## 4 简化电路原理图

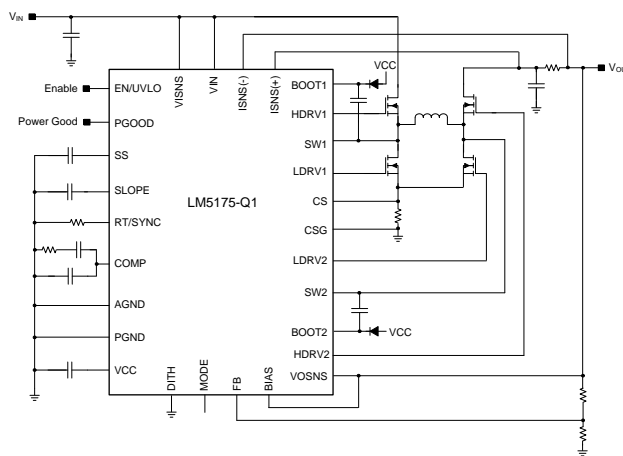

Copyright © 2016, Texas Instruments Incorporated



## 目录

<b>1</b>	特性 .....	<b>1</b>	8.3	Feature Description .....	<b>14</b>
<b>2</b>	应用 .....	<b>1</b>	8.4	Device Functional Modes .....	<b>19</b>
<b>3</b>	说明 .....	<b>1</b>	<b>9</b>	<b>Application and Implementation</b> .....	<b>20</b>
<b>4</b>	简化电路原理图 .....	<b>1</b>	9.1	Application Information .....	<b>20</b>
<b>5</b>	修订历史记录 .....	<b>2</b>	9.2	Typical Application .....	<b>20</b>
<b>6</b>	<b>Pin Configuration and Functions</b> .....	<b>3</b>	<b>10</b>	<b>Power Supply Recommendations</b> .....	<b>27</b>
<b>7</b>	<b>Specifications</b> .....	<b>4</b>	<b>11</b>	<b>Layout</b> .....	<b>27</b>
7.1	Absolute Maximum Ratings .....	<b>4</b>	11.1	Layout Guidelines .....	<b>27</b>
7.2	ESD Ratings .....	<b>5</b>	11.2	Layout Example .....	<b>28</b>
7.3	Recommended Operating Conditions .....	<b>5</b>	<b>12</b>	器件和文档支持 .....	<b>29</b>
7.4	Thermal Information .....	<b>5</b>	12.1	文档支持 .....	<b>29</b>
7.5	Electrical Characteristics .....	<b>6</b>	12.2	社区资源 .....	<b>29</b>
7.6	Typical Characteristics .....	<b>9</b>	12.3	商标 .....	<b>29</b>
<b>8</b>	<b>Detailed Description</b> .....	<b>12</b>	12.4	静电放电警告 .....	<b>29</b>
8.1	Overview .....	<b>12</b>	12.5	Glossary .....	<b>29</b>
8.2	Functional Block Diagram .....	<b>13</b>	<b>13</b>	机械、封装和可订购信息 .....	<b>29</b>
			13.1	Package Option Addendum .....	<b>30</b>

## 5 修订历史记录

日期	修订版本	注释
2016 年 4 月	*	最初发布版本

## 6 Pin Configuration and Functions

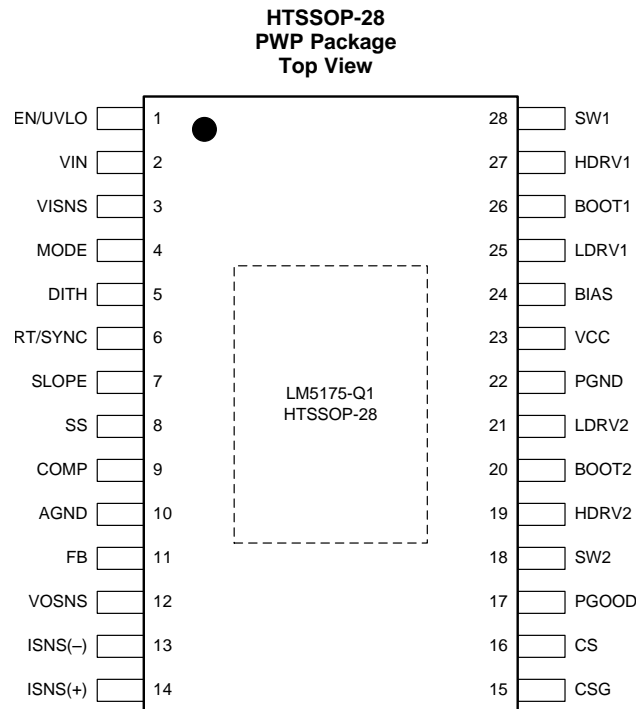

### Pin Functions

PIN		DESCRIPTION
NO.	NAME	
1	EN/UVLO	Enable pin. For EN/UVLO < 0.4 V, the LM5175-Q1 is in a low current shutdown mode. For 0.7 V < EN/UVLO < 1.23 V, the controller operates in standby mode in which the VCC regulator is enabled but the PWM controller is not switching. For EN/UVLO > 1.23 V, the PWM function is enabled, provided VCC exceeds the VCC UV threshold.
2	VIN	The input supply pin to the IC. Connect V <sub>IN</sub> to a supply voltage between 3.5 V and 42 V.
3	VISNS	V <sub>IN</sub> sense input. Connect to the input capacitor.
4	MODE	<p>Mode = GND, DCM, Hiccup Disabled (Set R<sub>MODE</sub> resistor to GND = 0 Ω)</p> <p>Mode = 1.00 V, DCM, Hiccup Enabled (Set R<sub>MODE</sub> resistor to GND = 49.9 kΩ)</p> <p>Mode = 1.85 V, CCM, Hiccup Enabled (Set R<sub>MODE</sub> resistor to GND = 93.1 kΩ)</p> <p>Mode = VCC, CCM, Hiccup Disabled (Set R<sub>MODE</sub> resistor to VCC = 0 Ω)</p>
5	DITH	A capacitor connected between the DITH pin and AGND is charged and discharged with a 10 uA current source. As the voltage on the DITH pin ramps up and down the oscillator frequency is modulated between -5% and +5% of the nominal frequency set by the RT resistor. Grounding the DITH pin will disable the dithering feature. In the external Sync mode, the DITH pin voltage is ignored.
6	RT/SYNC	Switching frequency programming pin. An external resistor is connected to the RT/SYNC pin and AGND to set the switching frequency. This pin can also be used to synchronize the PWM controller to an external clock.
7	SLOPE	A capacitor connected between the SLOPE pin and AGND provides the slope compensation ramp for stable current mode operation in both buck and boost mode.
8	SS	Soft-start programming pin. A capacitor between the SS pin and AGND pin programs soft-start time.
9	COMP	Output of the error amplifier. An external RC network connected between COMP and AGND compensates the regulator feedback loop.
10	AGND	Analog ground of the IC.
11	FB	Feedback pin for output voltage regulation. Connect a resistor divider network from the output of the converter to the FB pin.

**Pin Functions (continued)**

PIN		DESCRIPTION
NO.	NAME	
12	VOSNS	$V_{OUT}$ sense input. Connect to the output capacitor.
13 14	ISNS(-) ISNS(+)	Input or Output Current Sense Amplifier inputs. An optional current sense resistor connected between ISNS(+) and ISNS(-) can be located either on the input side or on the output side of the converter. If the sensed voltage across the ISNS(+) and ISNS(-) pins reaches 50 mV, a slow Constant Current (CC) control loop becomes active and starts discharging the soft-start capacitor to regulated the drop across ISNS(+) and ISNS(-) to 50 mV. Short ISNS(+) and ISNS(-) together to disable this feature.
15	CSG	The negative or ground input to the PWM current sense amplifier. Connect directly to the low-side (ground) of the current sense resistor.
16	CS	The positive input to the PWM current sense amplifier.
17	PGOOD	Power Good open drain output. PGOOD is pulled low when FB is outside a 0.8 V $\pm$ 10% regulation window.
18 28	SW2 SW1	The boost and the buck side switching nodes respectively.
19 27	HDRV2 HDRV1	Output of the high-side gate drivers. Connect directly to the gates of the high-side MOSFETs.
20 26	BOOT2 BOOT1	An external capacitor is required between the BOOT1, BOOT2 pins and the SW1, SW2 pins respectively to provide bias to the high-side MOSFET gate drivers.
21 25	LDRV2 LDRV1	Output of the low-side gate drivers. Connect directly to the gates of the low-side MOSFETs.
22	PGND	Power ground of the IC. The high current ground connection to the low-side gate drivers.
23	VCC	Output of the VCC bias regulator. Connect capacitor to ground.
24	BIAS	Optional input to the VCC bias regulator. Powering VCC from an external supply instead of $V_{IN}$ can reduce power loss at high $V_{IN}$ . For $V_{BIAS} > 8$ V, the VCC regulator draws power from the BIAS pin. The BIAS pin voltage must not exceed 40 V.
-	PowerPAD™	The PowerPAD should be soldered to the analog ground. If possible, use thermal vias to connect to a PCB ground plane for improved power dissipation.

## 7 Specifications

### 7.1 Absolute Maximum Ratings<sup>(1)</sup>

	MIN	MAX	UNIT
VIN, EN/UVLO, VISNS, VOSNS, ISNS(+), ISNS(-)	-0.3	60	V
BIAS	-0.3	40	
FB, SS, DITH, SLOPE, COMP	-0.3	3.6	
RT/SYNC	-0.3	6	
SW1, SW2	-1	60	
SW1, SW2 (20 ns transient)	-3.0	65	
VCC, MODE, PGOOD	-0.3	8.5	
LDRV1, LDRV2	-0.3	8.5	
BOOT1, HDRV1 with respect to SW1	-0.3	8.5	
BOOT2, HDRV2 with respect to SW2	-0.3	8.5	
BOOT1, BOOT2	-0.3	68	
CS, CSG	-0.3	0.3	
Maximum junction temperature <sup>(2)</sup>	-40	150	
Storage temperature, T <sub>stg</sub>	-65	150	

(1) Stresses beyond those listed under *Absolute Maximum Ratings* may cause permanent damage to the device. These are stress ratings only, which do not imply functional operation of the device at these or any other conditions beyond those indicated under *Recommended Operating Conditions*. Exposure to absolute-maximum-rated conditions for extended periods may affect device reliability.

(2) High junction temperatures degrade operating lifetimes. Operating lifetime is de-rated for junction temperatures greater than 125°C.

## 7.2 ESD Ratings

			VALUE	UNIT
V <sub>(ESD)</sub> Electrostatic discharge	Human-body model (HBM), per AEC Q100-002 <sup>(1)</sup>		±2000	V
	Charged-device model (CDM), per AEC Q100-011	All pins	±500	
		Corner pins	±750	

(1) AEC Q100-002 indicates that HBM stressing shall be in accordance with the ANSI/ESDA/JEDEC JS-001 specification.

## 7.3 Recommended Operating Conditions

over operating free-air temperature range (unless otherwise noted)<sup>(1)</sup>

		MIN	NOM	MAX	UNIT
V <sub>IN</sub>	Input voltage range	3.5		42	V
BIAS	Bias supply voltage range	8		36	
V <sub>OUT</sub>	Output voltage range	0.8		55	
EN/UVLO	Enable voltage range	0		42	
ISNS(+), ISNS(-)	Average current sense common mode range	0		55	
T <sub>J</sub>	Operating temperature range <sup>(2)</sup>	-40		150	°C
F <sub>sw</sub>	Operating frequency range	100		600	kHz

(1) *Recommended Operating Conditions* are conditions under the device is intended to be functional. For specifications and test conditions, see [Electrical Characteristics](#).

(2) High junction temperatures degrade operating lifetimes. Operating lifetime is de-rated for junction temperatures greater than 125°C.

## 7.4 Thermal Information

THERMAL METRIC <sup>(1)</sup>		LM5175-Q1	UNIT
		HTSSOP (PWP)	
		28 PINS	
R <sub>θJA</sub>	Junction-to-ambient thermal resistance	33.1	°C/W
R <sub>θJC(top)</sub>	Junction-to-case (top) thermal resistance	17.7	
R <sub>θJB</sub>	Junction-to-board thermal resistance	14.9	
ψ <sub>JT</sub>	Junction-to-top characterization parameter	0.4	
ψ <sub>JB</sub>	Junction-to-board characterization parameter	14.7	
R <sub>θJC(bot)</sub>	Junction-to-case (bottom) thermal resistance	1.1	

(1) For more information about traditional and new thermal metrics, see the IC Package Thermal Metrics application report, [SPRA953](#).

## 7.5 Electrical Characteristics

Typical values correspond to  $T_J = 25^\circ\text{C}$ . Minimum and maximum limits apply over the  $T_J = -40^\circ\text{C}$  to  $125^\circ\text{C}$  junction temperature range unless otherwise stated.  $V_{IN} = 24\text{ V}$  unless otherwise stated.<sup>(1)(2)</sup>

PARAMETER		TEST CONDITION	MIN	TYP	MAX	UNIT
<b>SUPPLY CURRENT</b>						
$I_Q$	$V_{IN}$ shutdown current	$V_{EN/UVLO} = 0\text{ V}$		1.4	10	$\mu\text{A}$
	$V_{IN}$ operating current	$V_{EN/UVLO} = 2\text{ V}$ , $V_{FB} = 0.9\text{ V}$		1.65	4	$\text{mA}$
<b>VCC</b>						
$V_{VCC(VIN)}$	Regulation voltage	$V_{BIAS} = 0\text{ V}$ , VCC open	6.95	7.35	7.88	V
$V_{UV(VCC)}$	VCC Undervoltage lockout	VCC increasing	3.11	3.27	3.43	
	Undervoltage hysteresis			160		mV
$I_{VCC}$	VCC current limit	$V_{VCC} = 0\text{ V}$	65			$\text{mA}$
$R_{OUT(VCC)}$	VCC regulator output impedance	$I_{VCC} = 30\text{ mA}$ , $V_{IN} = 3.5\text{ V}$		9.3	16	$\Omega$
<b>BIAS</b>						
$V_{BIAS(SW)}$	BIAS switchover voltage	$V_{IN} = 24\text{ V}$	7.25	8	8.75	V
<b>EN/UVLO</b>						
$V_{EN(STBY)}$	Standby threshold	EN/UVLO rising	0.55	0.79	0.97	V
$I_{EN(STBY)}$	Standby source current	$V_{EN/UVLO} = 1.1\text{ V}$	1	2	3	$\mu\text{A}$
$V_{EN(OP)}$	Operating threshold	EN/UVLO rising	1.15	1.23	1.29	V
$\Delta I_{HYS(OP)}$	Operating hysteresis current	$V_{EN/UVLO} = 1.5\text{ V}$	1.5	3.5	5.5	$\mu\text{A}$
<b>SS</b>						
$I_{SS}$	Soft-start pull up current	$V_{SS} = 0\text{ V}$	4.0	5.65	7.25	$\mu\text{A}$
$V_{SS(CL)}$	SS clamp voltage	SS open		1.27		V
$V_{FB} - V_{SS}$	FB to SS offset	$V_{SS} = 0\text{ V}$		-15		mV
<b>EA (ERROR AMPLIFIER)</b>						
$V_{REF}$	Feedback reference voltage	FB = COMP	0.788	0.800	0.812	V
$g_{mEA}$	Error amplifier gm			1.27		mS
$I_{SINK}/I_{SOURCE}$	COMP sink/source current	$V_{FB} = V_{REF} \pm 300\text{ mV}$		280		$\mu\text{A}$
$R_{OUT}$	Amplifier output resistance			20		$\text{M}\Omega$
BW	Unity gain bandwidth			2		MHz
$I_{BIAS(FB)}$	Feedback pin input bias current	FB in regulation			100	nA
<b>FREQUENCY</b>						
$f_{SW(1)}$	Switching Frequency 1	$R_T = 133\text{ k}\Omega$	180	200	220	kHz
$f_{SW(2)}$	Switching Frequency 2	$R_T = 47\text{ k}\Omega$	430	500	565	

- (1) All minimum and maximum limits are specified by correlating the electrical characteristics to process and temperature variations and applying statistical process control.
- (2) The junction temperature ( $T_J$  in  $^\circ\text{C}$ ) is calculated from the ambient temperature ( $T_A$  in  $^\circ\text{C}$ ) and power dissipation ( $P_D$  in Watts) as follows:  $T_J = T_A + (P_D \cdot R_{\theta JA})$  where  $R_{\theta JA}$  (in  $^\circ\text{C}/\text{W}$ ) is the package thermal impedance provided in the [Thermal Information](#) section.

## Electrical Characteristics (continued)

Typical values correspond to  $T_J = 25^\circ\text{C}$ . Minimum and maximum limits apply over the  $T_J = -40^\circ\text{C}$  to  $125^\circ\text{C}$  junction temperature range unless otherwise stated.  $V_{IN} = 24\text{ V}$  unless otherwise stated.<sup>(1)(2)</sup>

PARAMETER		TEST CONDITION	MIN	TYP	MAX	UNIT
<b>DITHER</b>						
$I_{DITHER}$	Dither source/sink current			10.5		$\mu\text{A}$
$V_{DITHER}$	Dither high threshold			1.27		V
	Dither low threshold			1.16		
<b>SYNC</b>						
$V_{SYNC}$	Sync input high threshold		2.1			V
	Sync input low threshold				1.2	
$PW_{SYNC}$	Sync input pulse width		75		500	ns
<b>CURRENT LIMIT</b>						
$V_{CS(BUCK)}$	Buck current limit threshold (Valley)	$V_{IN} = V_{VISNS} = 24\text{ V}$ , $V_{VOSNS} = 12\text{ V}$ , $V_{SLOPE} = 0\text{ V}$ , $T_J = 25^\circ\text{C}$	53.2	76	98	mV
$V_{CS(BOOST)}$	Boost current limit threshold (Peak)	$V_{IN} = V_{VISNS} = 12\text{ V}$ , $V_{VOSNS} = 24\text{ V}$ , $V_{SLOPE} = 0\text{ V}$ , $T_J = 25^\circ\text{C}$	114	160	202	
$I_{BIAS(CS/CSG)}$	CS/CSG pin bias current	$V_{CS} = V_{CSG} = 0\text{ V}$		-75		$\mu\text{A}$
$I_{OFFSET(CS/CSG)}$	CSG pin bias current	$V_{CS} = V_{CSG} = 0\text{ V}$			14	
<b>CONSTANT CURRENT LOOP</b>						
$V_{SNS}$	Average current loop regulation target	$V_{ISNS(-)} = 24\text{ V}$ , sweep $ISNS(+)$ , $V_{SS} = 0.8\text{ V}$	43	50	57	mV
$I_{SNS}$	$ISNS(+)$ / $ISNS(-)$ pin bias currents	$V_{ISNS(+)} = V_{ISNS(-)} = V_{IN} = 24\text{ V}$		7		$\mu\text{A}$
Gm	gm of soft-start pull down amplifier	$V_{ISNS(+)} - V_{ISNS(-)} = 50\text{ mV}$ , $V_{SS} = 0.5\text{ V}$		1		mS
<b>SLOPE</b>						
$I_{SLOPE}$	Buck adaptive slope current	$V_{VISNS} = 24\text{ V}$ , $V_{VOSNS} = 12\text{ V}$ , $V_{SLOPE} = 0\text{ V}$	24	30	35	$\mu\text{A}$
	Boost adaptive slope current	$V_{VISNS} = 12\text{ V}$ , $V_{VOSNS} = 18\text{ V}$ , $V_{SLOPE} = 0\text{ V}$	13	17	21	
$gm_{SLOPE}$	Slope compensation amplifier gm			2		$\mu\text{S}$
<b>MODE</b>						
$I_{MODE}$	Source current out of MODE pin		17	20	23	$\mu\text{A}$
$V_{DCM\_HIC}$	DCM with hiccup threshold		0.60	0.7	0.76	V
$V_{CCM\_HIC}$	CCM with hiccup threshold		1.18	1.28	1.38	
$V_{CCM}$	CCM no hiccup threshold		2.22	2.4	2.6	

**Electrical Characteristics (continued)**

Typical values correspond to  $T_J = 25^\circ\text{C}$ . Minimum and maximum limits apply over the  $T_J = -40^\circ\text{C}$  to  $125^\circ\text{C}$  junction temperature range unless otherwise stated.  $V_{IN} = 24\text{ V}$  unless otherwise stated.<sup>(1)(2)</sup>

PARAMETER		TEST CONDITION	MIN	TYP	MAX	UNIT
<b>PGOOD</b>						
$V_{PGD}$	PGOOD trip threshold for falling FB	Measured with respect to $V_{REF}$		-9%		
	PGOOD trip threshold for rising FB	Measured with respect to $V_{REF}$		10%		
	Hysteresis			2%		
$I_{LEAK(PGD)}$	PGOOD leakage current				100	nA
$I_{SINK(PGD)}$	PGOOD sink current	$V_{PGOOD} = 0.4\text{ V}$	2	4.2	6.5	mA
<b>OUTPUT OVP</b>						
$V_{OVP}$	Output overvoltage threshold	At the FB pin		0.86		V
	Hysteresis			21		mV
<b>NMOS DRIVERS</b>						
$I_{HDRV1,2}$	Driver peak source current	$V_{BOOT} - V_{SW} = 7\text{ V}$		1.8		A
	Driver peak sink current	$V_{BOOT} - V_{SW} = 7\text{ V}$		2.2		
$I_{LDRV1,2}$	Driver peak source current			1.8		
	Driver peak sink current			2.2		
$R_{HDRV1,2}$	Driver pull up resistance	$V_{BOOT} - V_{SW} = 7\text{ V}$		1.9		$\Omega$
	Driver pull down resistance	$V_{BOOT} - V_{SW} = 7\text{ V}$		1.3		
$V_{UV(BOOT1,2)}$	BOOT1,2 to SW1,2 UVLO threshold	HDRV1,2 shut off		2.73		V
	BOOT1,2 to SW1,2 UVLO hysteresis	HDRV1,2 start switching		280		mV
	BOOT1,2 to SW1,2 threshold for refresh pulse			4.45		V
$R_{LDRV1,2}$	Driver pull up resistance			2		$\Omega$
	Driver pull down resistance			1.5		
$t_{DT1}$	Dead time HDRV1,2 off to LDRV1,2 on			55		ns
$t_{DT2}$	Dead time LDRV1,2 off to HDRV1,2 on			55		
<b>THERMAL SHUTDOWN</b>						
$T_{SD}$	Thermal shutdown temperature			165		$^\circ\text{C}$
$T_{SD(HYS)}$	Thermal shutdown hysteresis			15		

## 7.6 Typical Characteristics

At  $T_A = 25^\circ\text{C}$ , unless otherwise stated.

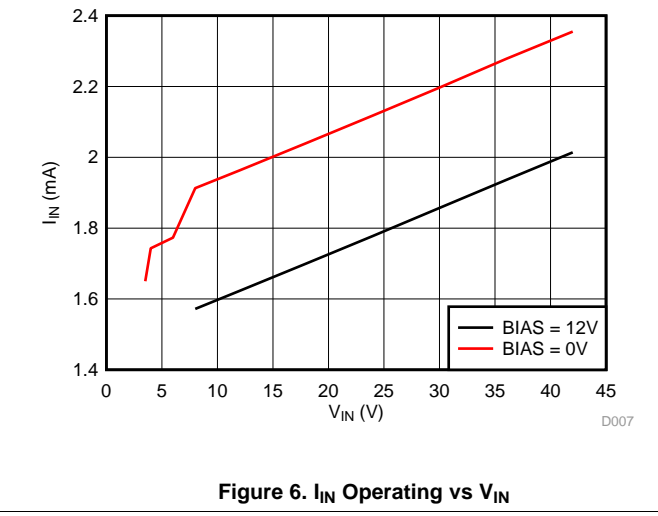
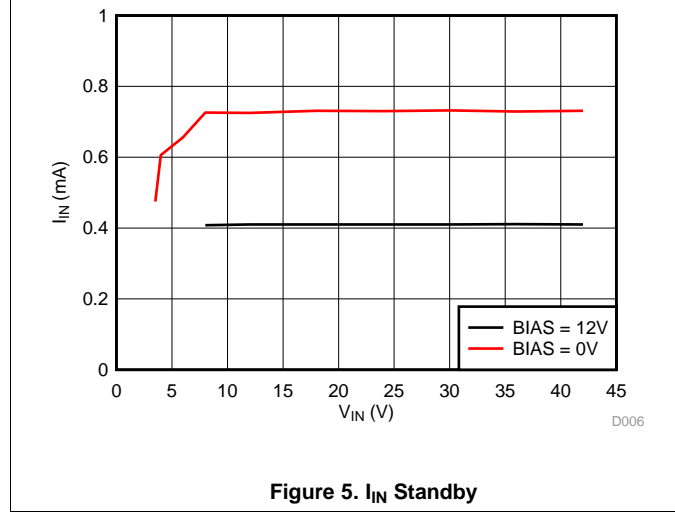
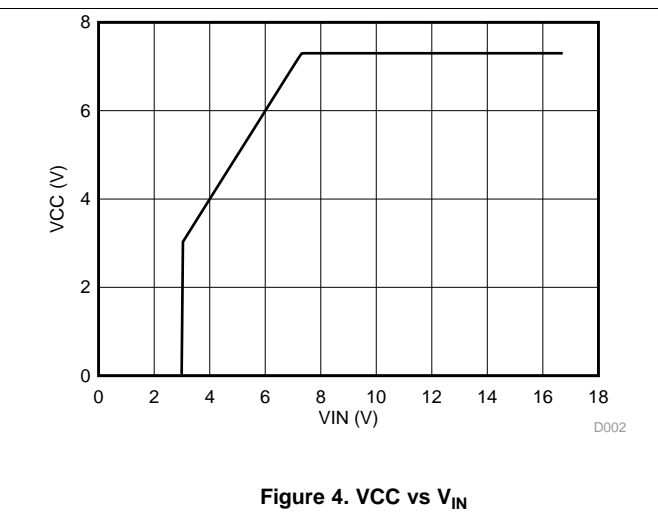
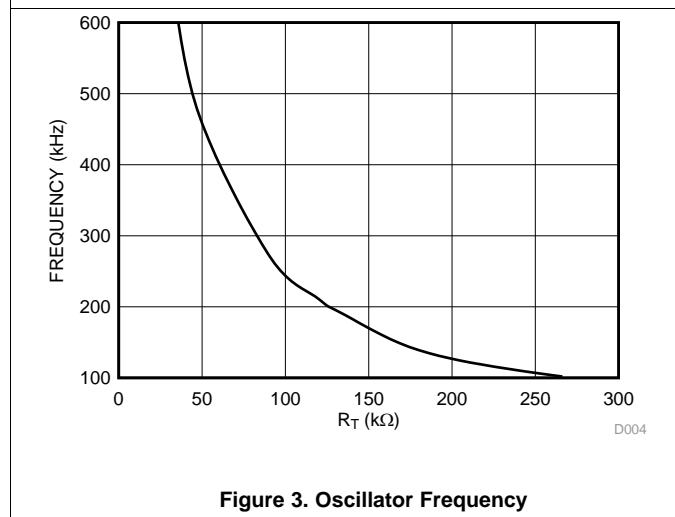
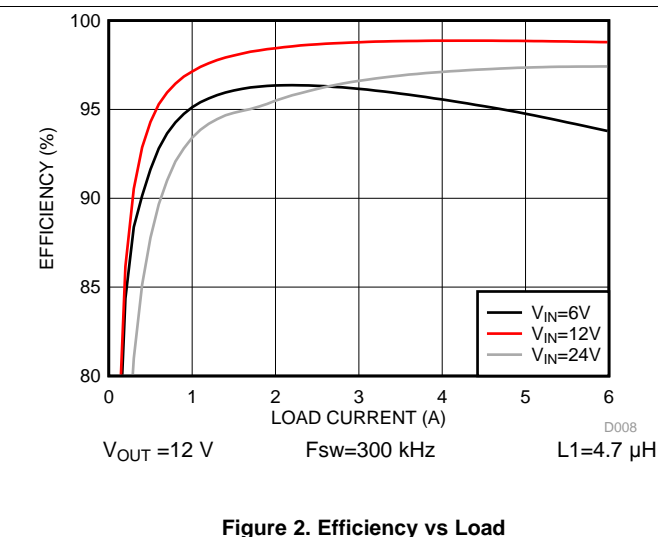
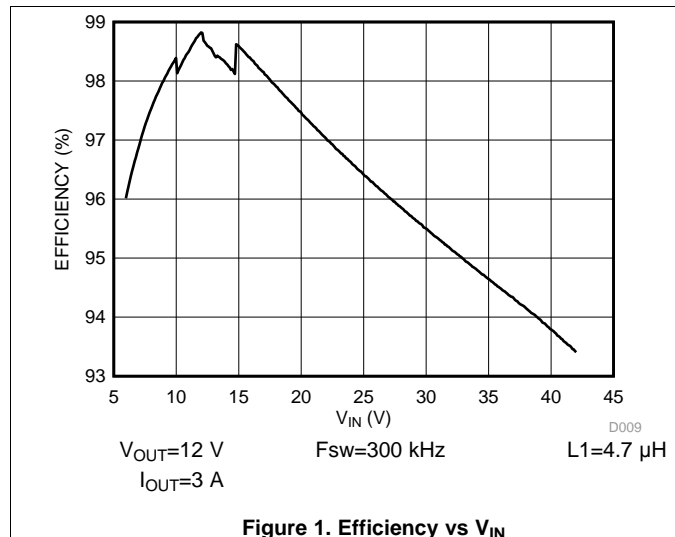

Typical Characteristics (continued)

At  $T_A = 25^\circ\text{C}$ , unless otherwise stated.

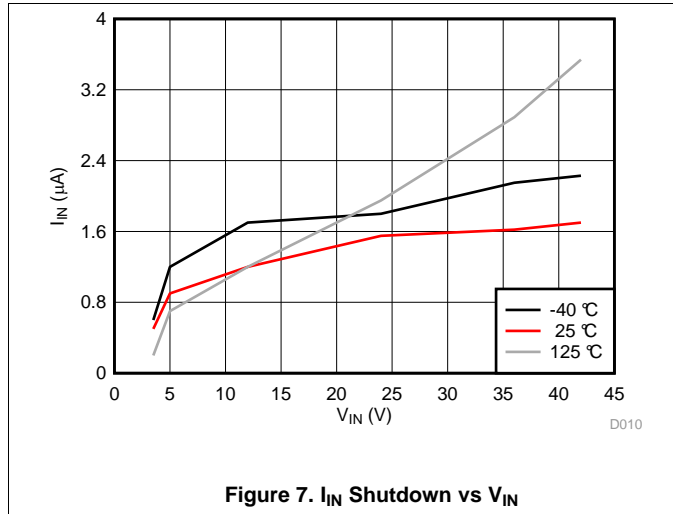

Figure 7.  $I_{IN}$  Shutdown vs  $V_{IN}$

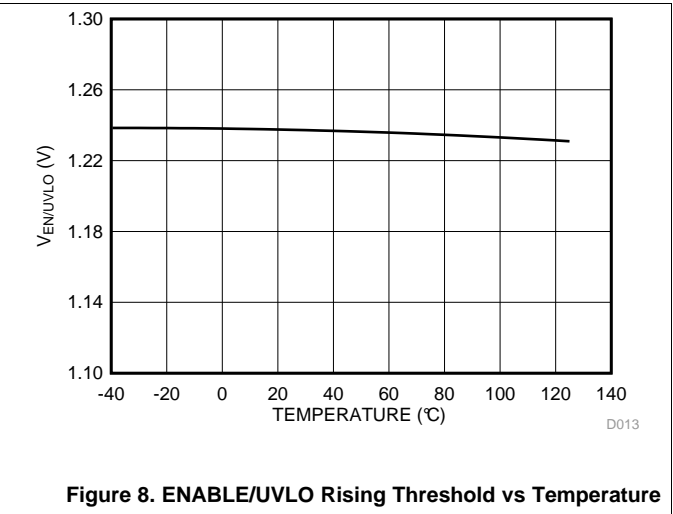

Figure 8. ENABLE/UVLO Rising Threshold vs Temperature

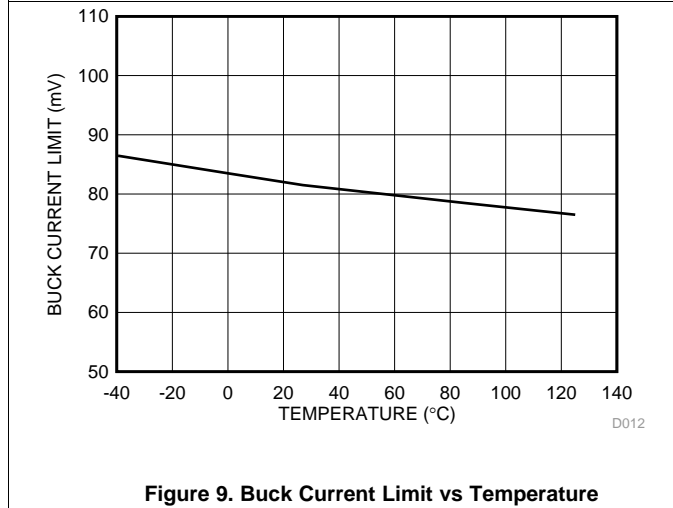

Figure 9. Buck Current Limit vs Temperature

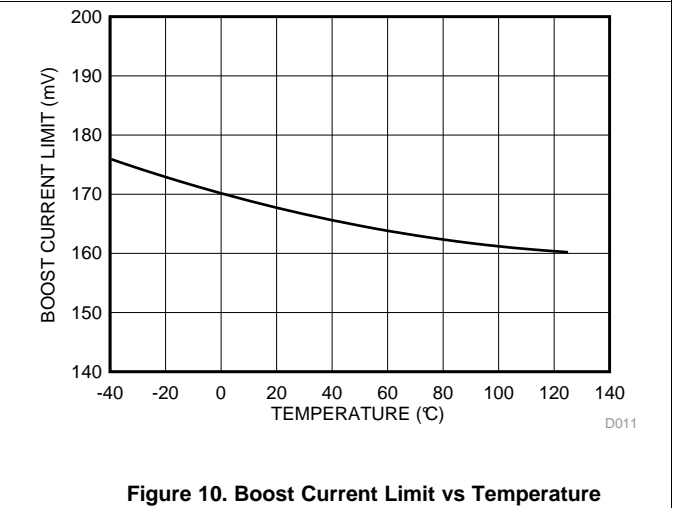

Figure 10. Boost Current Limit vs Temperature

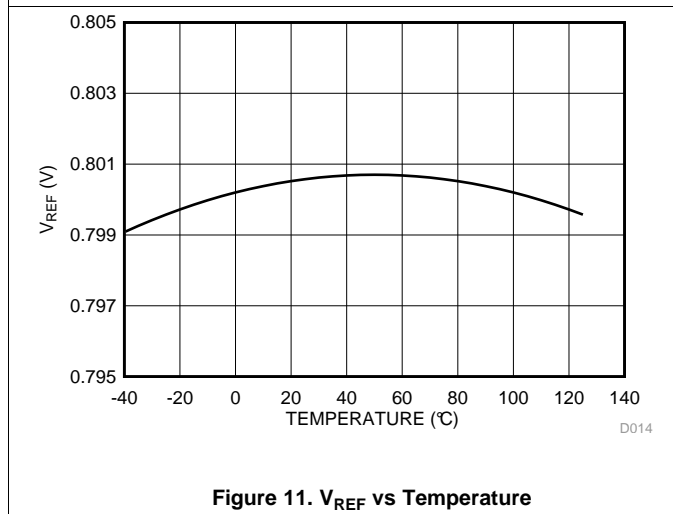

Figure 11.  $V_{REF}$  vs Temperature

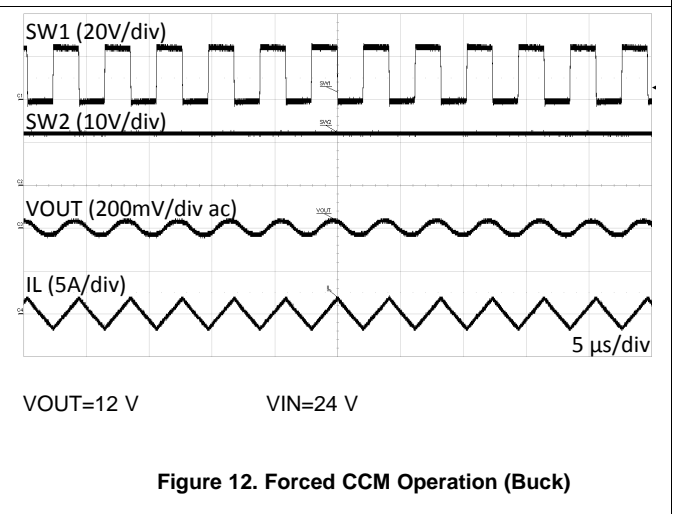
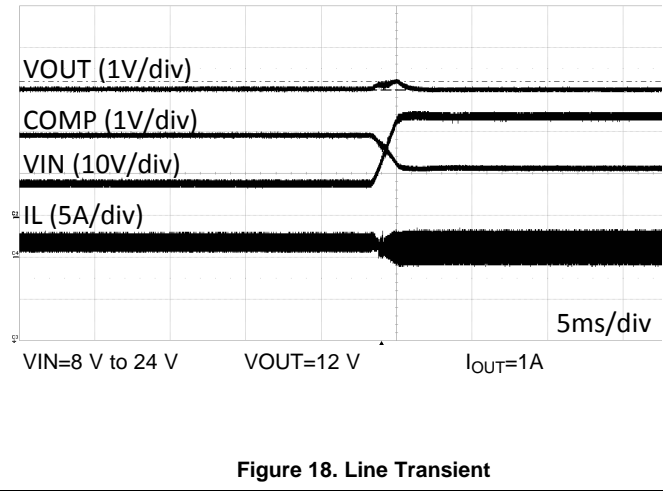
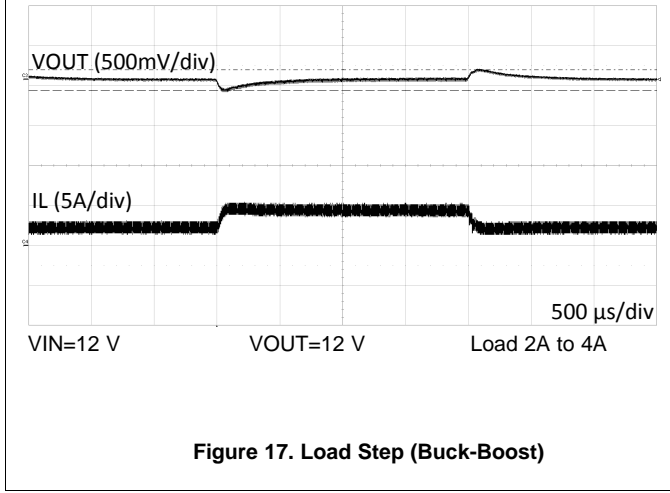
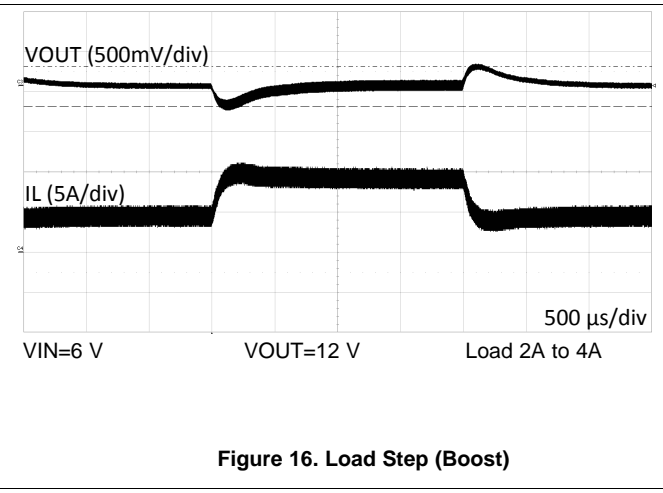
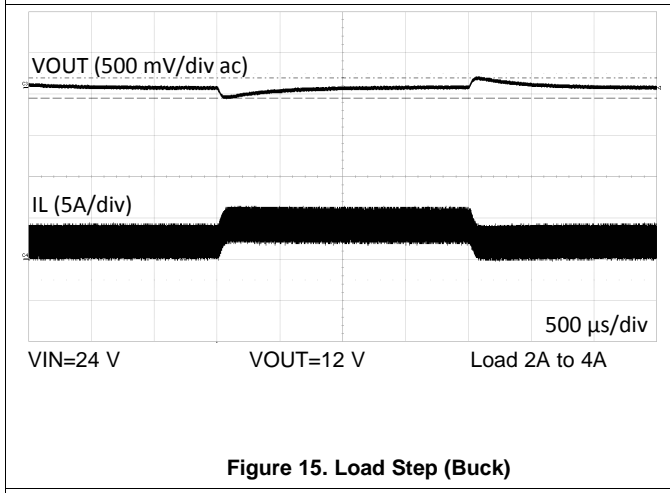
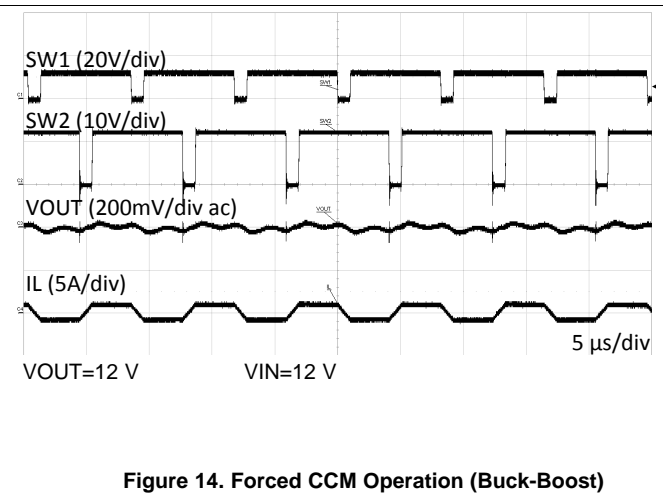
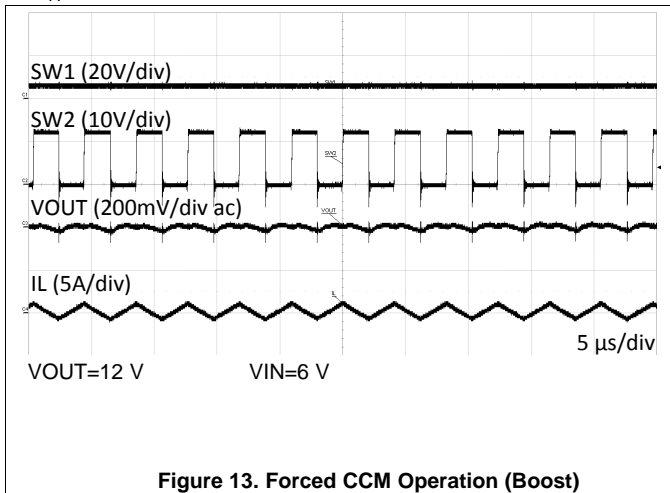

Figure 12. Forced CCM Operation (Buck)

### Typical Characteristics (continued)

At  $T_A = 25^\circ\text{C}$ , unless otherwise stated.



## Typical Characteristics (continued)

At  $T_A = 25^\circ\text{C}$ , unless otherwise stated.

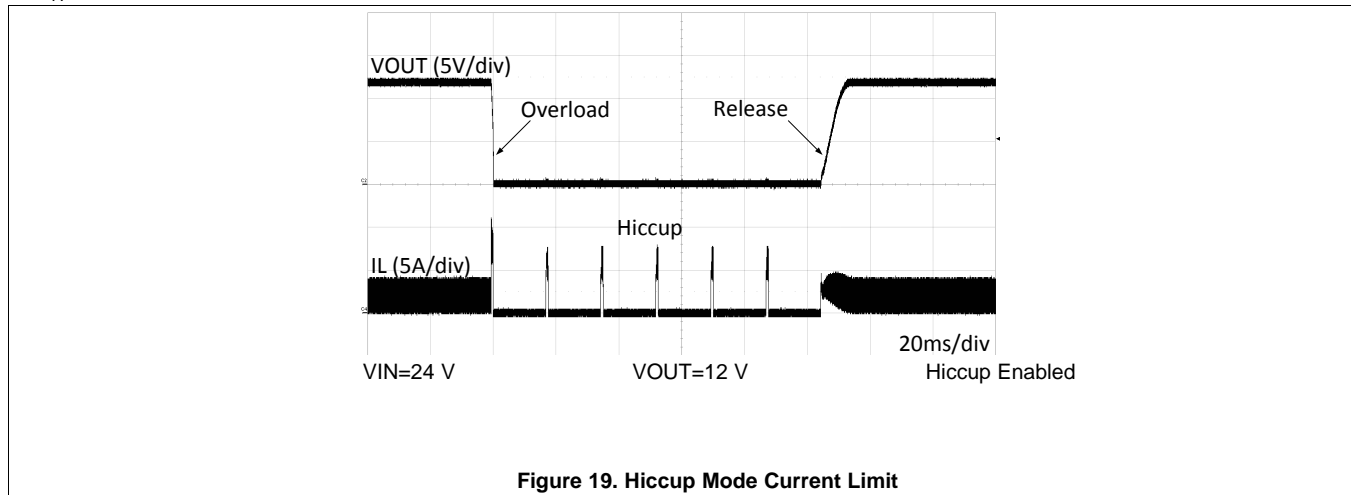

## 8 Detailed Description

### 8.1 Overview

The LM5175-Q1 is a wide input voltage four-switch buck-boost controller IC with integrated drivers for N-channel MOSFETs. It operates in the buck mode when  $V_{IN}$  is greater than  $V_{OUT}$  and in the boost mode when  $V_{IN}$  is less than  $V_{OUT}$ . When  $V_{IN}$  is close to  $V_{OUT}$ , the device operates in a proprietary transition buck or boost mode. The control scheme provides smooth operation for any input/output combination within the specified operating range. The buck or boost transition control scheme provides a low ripple output voltage when  $V_{IN}$  equals  $V_{OUT}$  without compromising the efficiency.

The LM5175-Q1 integrates four N-Channel MOSFET drivers including two low-side drivers and two high-side drivers, eliminating the need for external drivers or floating bias supplies. The internal VCC regulator supplies internal bias rails as well as the MOSFET gate drivers. The VCC regulator is powered either from the input voltage through the VIN pin or from the output or an external supply through the BIAS pin for improved efficiency.

The PWM control scheme is based on valley current mode control for buck operation and peak current mode control for boost operation. The inductor current is sensed through a single sense resistor in series with the low-side MOSFETs. The sensed current is also monitored for cycle-by-cycle current limit. The behavior of the LM5175-Q1 during an overload condition is dependent on the MODE pin programming (see [MODE Pin Configuration](#)). If hiccup mode fault protection is selected, the controller turns off after a fixed number of switching cycles in cycle-by-cycle current limit and restarts after another fixed number of clock cycles. The hiccup mode reduces the heating in the power components in a sustained overload condition. If hiccup mode is disabled through the MODE pin, the controller remains in a cycle-by-cycle current limit condition until the overload is removed. The MODE pin also selects continuous conduction mode (CCM) for noise sensitive applications or discontinuous conduction mode (DCM) for higher light load efficiency.

In addition to the cycle-by-cycle current limiting, the LM5175-Q1 also provides an optional average current regulation loop that can be configured for either input or output current limiting. This is useful for battery charging or other applications where a constant current behavior may be required.

The soft-start time of LM5175-Q1 is programmed by a capacitor connected to the SS pin to minimize the inrush current and overshoot during startup.

The precision EN/UVLO pin supports programmable input undervoltage lockout (UVLO) with hysteresis. The output overvoltage protection (OVP) feature turns off the high-side drivers when the voltage at the FB pin is 7.5% above the nominal 0.8-V  $V_{REF}$ . The PGOOD output indicates when the FB voltage is inside a  $\pm 10\%$  regulation window centered at  $V_{REF}$ .

## 8.2 Functional Block Diagram

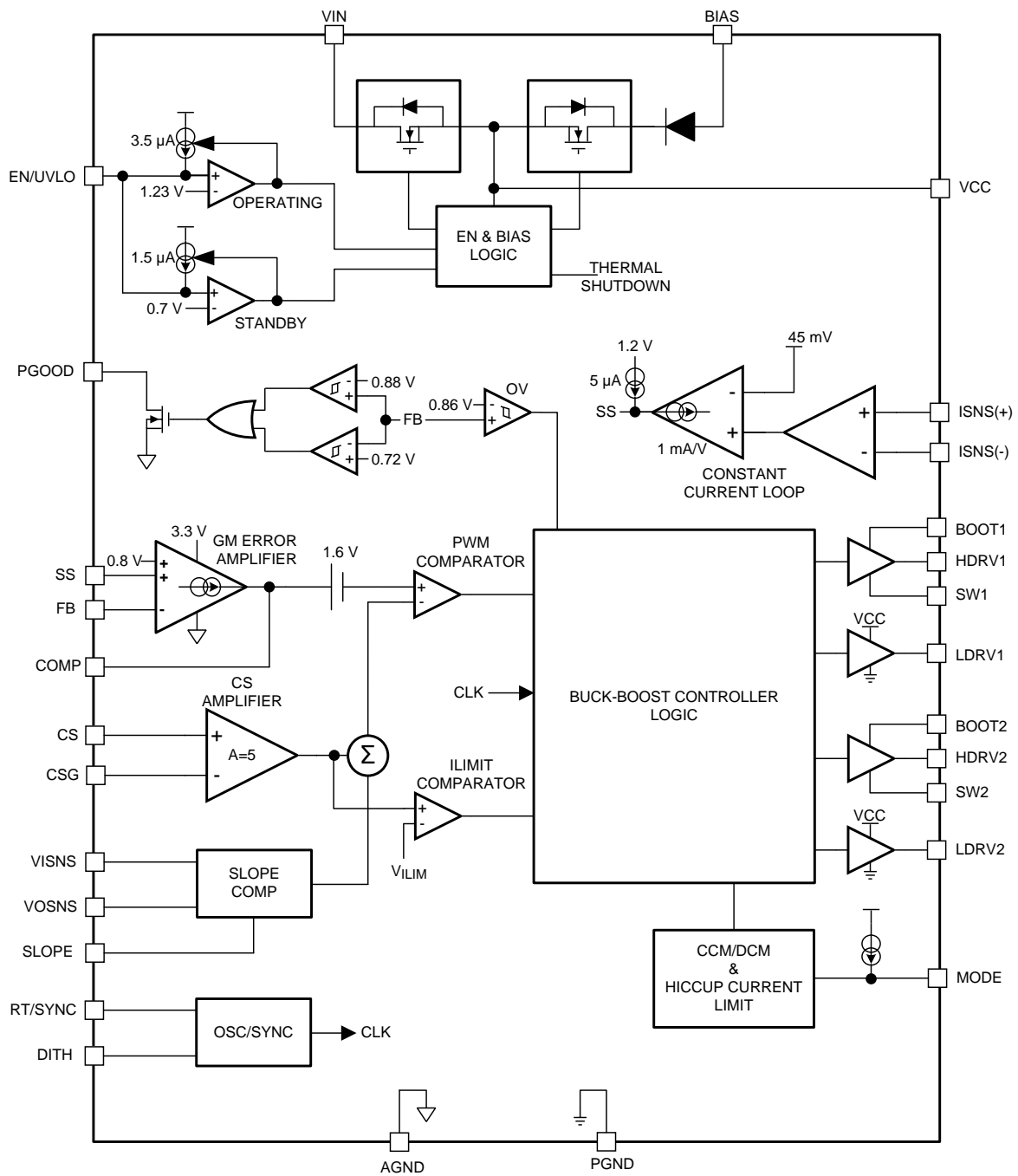

Copyright © 2016, Texas Instruments Incorporated

### 8.3 Feature Description

#### 8.3.1 Fixed Frequency Valley/Peak Current Mode Control with Slope Compensation

The LM5175-Q1 implements a fixed frequency current mode control of both the buck and boost switches. The output voltage, scaled down by the feedback resistor divider, appears at the FB pin and is compared to the internal reference ( $V_{REF}$ ) by an internal error amplifier. The error amplifier produces an error voltage by driving the COMP pin. An adaptive slope compensation signal based on  $V_{IN}$ ,  $V_{OUT}$ , and the capacitor at the SLOPE pin is added to the current sense signal measured across the CS and CSG pins. The result is compared to the COMP error voltage by the PWM comparator.

The LM5175-Q1 regulates the output using valley current mode control in buck mode and peak current mode control in boost mode. For valley current mode control, the high-side buck MOSFET controlled by HDRV1 is turned on by the PWM comparator at the valley of the inductor ripple current and turned off by the oscillator clock signal. Valley current mode control is advantageous for buck converters where the PWM controller must resolve very short on-times. For peak current mode control in the boost mode, the low-side boost MOSFET controlled by LDRV2 is turned on by the clock signal in each switching cycle and turned off by the PWM comparator at the peak of the inductor ripple current.

The low-side gate drive LDRV1, complementary to the HDRV1 drive signal, controls the synchronous rectification MOSFET of the buck stage. The high-side gate drive HDRV2, complementary to the low-side gate drive LDRV2, controls the high-side synchronous rectifier of the boost stage. For operation with  $V_{IN}$  close to  $V_{OUT}$ , the LM5175-Q1 uses a proprietary buck or boost transition scheme to achieve smooth, low ripple transition zone behavior.

Peak and valley current mode controllers require slope compensation for stable current loop operation at duty cycle greater than 50% in peak current mode control and less than 50% in valley current mode control. The LM5175-Q1 provides a SLOPE pin to program optimum slope for any  $V_{IN}$  and  $V_{OUT}$  combination using an external capacitor.

#### 8.3.2 VCC Regulator and Optional BIAS Input

The VCC regulator provides a regulated 7.5-V bias supply to the gate drivers. When EN/UVLO is above the 0.7-V (typical) standby threshold, the VCC regulator is turned on. For  $V_{IN}$  less than 7.5 V, the VCC voltage tracks  $V_{IN}$  with a small voltage drop as shown in Figure 4. If the EN/UVLO input is above the 1.23 V operating threshold and VCC exceeds the 3.3 V (typical) VCC UV threshold, the controller is enabled and switching begins.

The VCC regulator draws power from  $V_{IN}$  when there is no supply voltage connected to the BIAS pin. If the BIAS pin is connected to an external voltage source that exceeds VCC by one diode drop, the VCC regulator draws power from the BIAS input instead of  $V_{IN}$ . Connecting the BIAS pin to  $V_{OUT}$  in applications with  $V_{OUT}$  greater than 8.5 V improves the efficiency of the regulator in the buck mode. The BIAS pin voltage should not exceed 36 V.

For low  $V_{IN}$  operation, ensure that the VCC voltage is sufficient to fully enhance the MOSFETs. Use an external bias supply if  $V_{IN}$  dips below the voltage required to sustain the VCC voltage. For these conditions, use a series blocking diode between the input supply and the VIN pin (Figure 20). This prevents VCC from back-feeding into  $V_{IN}$  through the body diode of the VCC regulator.

A 1- $\mu$ F capacitor to PGND is required to supply the VCC regulator load transients.

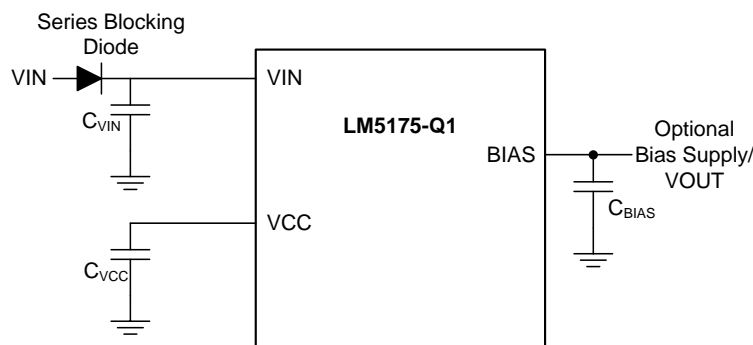

Copyright © 2016, Texas Instruments Incorporated

Figure 20. VCC Regulator

## Feature Description (continued)

### 8.3.3 Enable/UVLO

The LM5175-Q1 has a dual function enable and undervoltage lockout (UVLO) circuit. The EN/UVLO pin has three distinct voltage ranges: shutdown, standby, and operating (see [Shutdown, Standby, and Operating Modes](#)). When the EN/UVLO pin is below the standby threshold (0.7 V typical), the converter is held in a low power shutdown mode. When EN/UVLO voltage is greater than the standby threshold but less than the 1.23 V operating threshold, the internal bias rails and the VCC regulator are enabled but the soft-start (SS) pin is held low and the PWM controller is disabled. A 1.5  $\mu\text{A}$  pull-up current is sourced out of the EN/UVLO pin in standby mode to provide hysteresis between the shutdown mode and the standby mode. When EN/UVLO is greater than the 1.23 V operating threshold, the controller commences operation if VCC is above VCC UV threshold (3.3 V). A hysteresis current of 3.5  $\mu\text{A}$  is sourced into the EN/UVLO pin when the EN/UVLO input exceeds the 1.23 V operation threshold to provide hysteresis that prevents on/off chattering in the presence of noise with a slowly changing input voltage.

The  $V_{\text{IN}}$  undervoltage lockout turn-on threshold is typically set by a resistor divider from the VIN pin to AGND with the mid-point of the divider connected to EN/UVLO. The turn-on threshold  $V_{\text{IN(UV)}}$  is calculated using [Equation 1](#) where  $R_{\text{UV2}}$  is the upper resistor and  $R_{\text{UV1}}$  is the lower resistor in the EN/UVLO resistor divider:

$$V_{\text{IN(UV)}} = 1.23 \text{ V} \times \left( 1 + \frac{R_{\text{UV2}}}{R_{\text{UV1}}} \right) - R_{\text{UV2}} \times 1.5 \mu\text{A} \quad (1)$$

The hysteresis between the UVLO turn-on threshold and turn-off threshold is set by the upper resistor in the EN/UVLO resistor divider and is given by:

$$\Delta V_{\text{HYS(UV)}} = 3.5 \mu\text{A} \times R_{\text{UV2}} \quad (2)$$

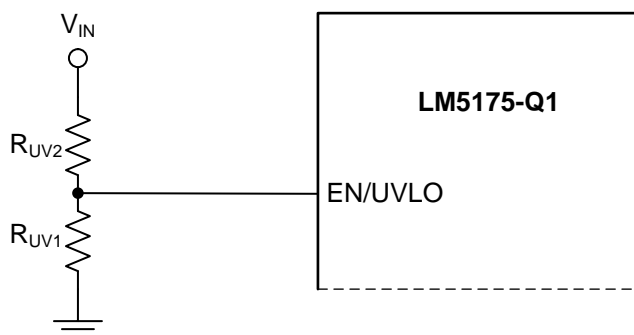

Copyright © 2016, Texas Instruments Incorporated

**Figure 21. UVLO Threshold Programming**

### 8.3.4 Soft-Start

The LM5175-Q1 soft-start time is programmed using a soft-start capacitor from the SS pin to AGND. When the converter is enabled, an internal 5- $\mu\text{A}$  current source charges the soft-start capacitor. When the SS pin voltage is below the 0.8-V feedback reference voltage  $V_{\text{REF}}$ , the soft-start pin controls the regulated FB voltage. Once SS exceeds  $V_{\text{REF}}$ , the soft-start interval is complete and the error amplifier is referenced to  $V_{\text{REF}}$ . The soft-start time is given by [Equation 3](#):

$$t_{\text{ss}} = \frac{C_{\text{SS}} \times 0.8 \text{ V}}{5 \mu\text{A}} \quad (3)$$

The soft-start capacitor is internally discharged when the converter is disabled because of EN/UVLO falling below the operation threshold or VCC falling below the VCC UV threshold. The soft-start pin is also discharged when the converter is in hiccup mode current limiting or in thermal shutdown. When average input or output current limiting is active, the soft-start capacitor is discharged by the constant current loop transconductance (gm) amplifier to limit either input or output current.

## Feature Description (continued)

### 8.3.5 Overcurrent Protection

The LM5175-Q1 provides cycle-by-cycle current limit to protect against overcurrent and short circuit conditions. In buck operation, the sensed valley voltage across the CSG and CS pins is limited to 76 mV. The high-side buck switch skips a cycle if the sensed voltage does not fall below this threshold during the buck switch off time. In boost operation, the maximum peak voltage across CS and CSG is limited to 160 mV. If the peak current in the low-side boost switch causes the CS pin to exceed this threshold voltage, the boost switch is turned off for the remainder of the clock cycle.

Applying the appropriate voltage to the MODE pin of the LM5175-Q1 enables hiccup mode fault protection (see [MODE Pin Configuration](#)). In the hiccup mode, the controller shuts down after detecting cycle-by-cycle current limiting for 128 consecutive cycles and the soft-start capacitor is discharged. The soft-start capacitor is automatically released after 4000 oscillator clock cycles and the controller restarts. If hiccup mode protection is not enabled through the MODE pin, the LM5175-Q1 will operate in cycle-by-cycle current limiting as long as the overload condition persists.

### 8.3.6 Average Input/Output Current Limiting

The LM5175-Q1 provides optional average current limiting capability to limit either the input or the output current of the DC/DC converter. The average current limiting circuit uses an additional current sense resistor connected in series with the input supply or output voltage of the converter. A current sense gm amplifier with inputs at the ISNS(+) and ISNS(-) pins monitors the voltage across the sense resistor and compares it with an internal 50 mV reference. If the drop across the sense resistor is greater than 50 mV, the gm amplifier gradually discharges the soft-start capacitor. When the soft-start capacitor discharges below the 0.8-V feedback reference voltage  $V_{REF}$ , the output voltage of the converter decreases to limit the input or output current. The average current limiting feature can be used in applications requiring a regulated current from the input supply or into the load. The target constant current is given by [Equation 4](#):

$$I_{CL(AVG)} = \frac{50 \text{ mV}}{R_{SNS}} \quad (4)$$

The average current loop can be disabled by shorting the ISNS(+) and ISNS(-) pins together.

### 8.3.7 CCM/DCM Operation

The LM5175-Q1 allows selection of continuous conduction mode (CCM) or discontinuous conduction mode (DCM) operation using the MODE pin (see [MODE Pin Configuration](#)). In CCM operation the inductor current can flow in either direction and the controller switches at a fixed frequency regardless of the load current. This mode is useful for noise-sensitive applications where a fixed switching eases filter design. In DCM operation the synchronous rectifier MOSFETs emulate diodes as LDRV1 or HDRV2 turn-off for the remainder of the PWM cycle when the inductor current reaches zero. The DCM mode results in reduced frequency operation at light loads, which lowers switching losses and increases light load efficiency of the converter.

### 8.3.8 Frequency and Synchronization (RT/SYNC)

The LM5175-Q1 switching frequency can be programmed between 100 kHz and 600 kHz using a resistor from the RT/SYNC pin to AGND. The  $R_T$  resistor is related to the nominal switching frequency ( $F_{sw}$ ) by the following equation:

$$R_T = \frac{\left(\frac{1}{F_{sw}}\right) - 200 \text{ ns}}{37 \text{ pF}} \quad (5)$$

[Figure 3](#) in the [Typical Characteristics](#) shows the relationship between the programmed switching frequency ( $F_{sw}$ ) and the  $R_T$  resistor.

### Feature Description (continued)

The RT/SYNC pin can also be used for synchronizing the internal oscillator to an external clock signal. The external synchronization pulse is ac coupled using a capacitor to the RT/SYNC pin. The voltage at the RT/SYNC pin must not exceed 3.3 V peak. The external synchronization pulse frequency should be higher than the internally set oscillator frequency and the pulse width should be between 75 ns and 500 ns.

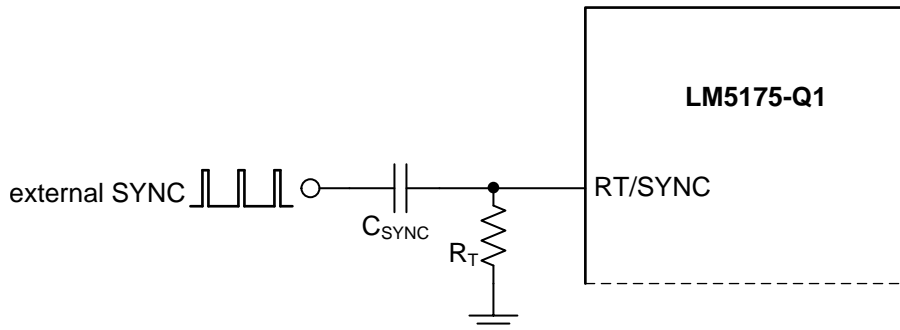

Copyright © 2016, Texas Instruments Incorporated

Figure 22. Using External SYNC

### 8.3.9 Frequency Dithering

The LM5175-Q1 provides an optional frequency dithering function that is enabled by connecting a capacitor from DITH to AGND. Figure 23 illustrates the dithering circuit. A triangular waveform centered at 1.22 V is generated across the C<sub>DITH</sub> capacitor. This triangular waveform modulates the oscillator frequency by ±5% of the nominal frequency set by the R<sub>T</sub> resistor. The C<sub>DITH</sub> capacitance value sets the rate of the low frequency modulation. A lower C<sub>DITH</sub> capacitance will modulate the oscillator frequency at a faster rate than a higher capacitance. For the dithering circuit to effectively reduce peak EMI, the modulation rate must be much less than the oscillator frequency (F<sub>sw</sub>). Equation 6 calculates the DITH pin capacitance required to set the modulation frequency, F<sub>MOD</sub>. Connecting the DITH pin directly to AGND disables frequency dithering, and the internal oscillator operates at a fixed frequency set by the RT resistor. Dither is disabled when external SYNC is used.

$$C_{DITH} = \frac{10 \mu A}{F_{MOD} \times 0.24 V} \quad (6)$$

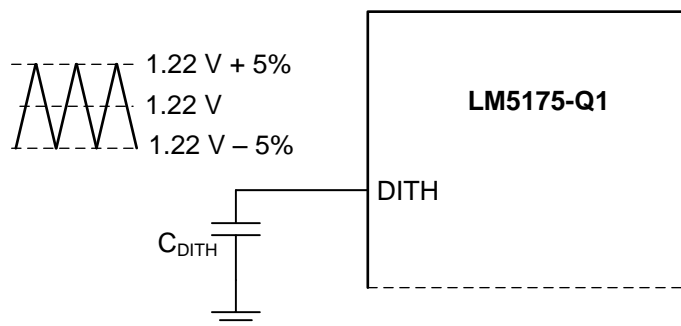

Copyright © 2016, Texas Instruments Incorporated

Figure 23. Dither Operation

### 8.3.10 Output Overvoltage Protection (OVP)

The LM5175-Q1 provides an output overvoltage protection (OVP) circuit that turns off the gate drives when the feedback voltage is 7.5% above the 0.8 V feedback reference voltage V<sub>REF</sub>. Switching resumes once the output falls within 5% of V<sub>REF</sub>.

## Feature Description (continued)

### 8.3.11 Power Good (PGOOD)

PGOOD is an open drain output that is pulled low when the voltage at the FB pin is outside  $-9\%$  /  $+10\%$  of the nominal 0.8-V reference voltage. The PGOOD internal N-Channel MOSFET pull-down strength is typically 4.2 mA. This pin can be connected to a voltage supply of up to 8 V through a pull-up resistor.

### 8.3.12 Gm Error Amplifier

The LM5175-Q1 has a gm error amplifier for loop compensation. The gm amplifier output (COMP) range is 0.3 V to 3 V. Connect an  $R_{c1}$ - $C_{c1}$  compensation network between COMP and ground for type II (PI) compensation (see [Figure 24](#)). Another pole is usually added using  $C_{c2}$  to suppress higher frequency noise.

The COMP output voltage ( $V_{COMP}$ ) range limits the possible  $V_{IN}$  and  $I_{OUT}$  range for a given design. In buck mode, the maximum  $V_{IN}$  for which the converter can regulate the output at no load is when  $V_{COMP}$  reaches 0.3 V. [Equation 7](#) gives  $V_{COMP}$  as a function of  $V_{IN}$  at no load in CCM buck mode:

$$V_{COMP(BUCK)} = 1.6 \text{ V} - A_{CS} \cdot R_{SENSE} \cdot \frac{V_{OUT}}{2 \cdot L1 \cdot F_{SW}} \cdot (1 - D_{BUCK}) - \frac{2 \mu\text{S} \cdot (V_{IN} - V_{OUT}) + 6 \mu\text{A}}{C_{SLOPE} \cdot F_{SW}} \cdot (1 - D_{BUCK}) \quad (7)$$

Where  $D_{BUCK}$  in the equation [Equation 7](#) is the buck duty cycle given by:

$$D_{BUCK} = \frac{V_{OUT}}{V_{IN}} \quad (8)$$

A larger L1, lower slope ripple (higher  $C_{SLOPE}$ ), smaller sense resistor ( $R_{SENSE}$ ), and higher frequency can increase the maximum  $V_{IN}$  range for buck operation.

For boost mode, the minimum  $V_{IN}$  for which the converter can regulate the output at full load is when  $V_{COMP}$  reaches 3 V. [Equation 9](#) gives  $V_{COMP}$  as a function of  $V_{IN}$  in boost mode:

$$V_{COMP(BOOST)} = 1.6 \text{ V} + A_{CS} \cdot R_{SENSE} \cdot \left( I_{OUT} \cdot \frac{V_{OUT}}{V_{IN}} + \frac{V_{IN}}{2 \cdot L1 \cdot F_{SW}} \cdot D_{BOOST} \right) + \frac{2 \mu\text{S} \cdot (V_{OUT} - V_{IN}) + 5 \mu\text{A}}{C_{SLOPE} \cdot F_{SW}} \cdot D_{BOOST} \quad (9)$$

Where  $D_{BOOST}$  in the [Equation 9](#) is the boost duty cycle given by:

$$D_{BOOST} = 1 - \frac{V_{IN}}{V_{OUT}} \quad (10)$$

A larger L1, lower slope ripple (higher  $C_{SLOPE}$ ), smaller sense resistor ( $R_{SENSE}$ ), and higher frequency can extend the minimum  $V_{IN}$  range for boost operation.

### 8.3.13 Integrated Gate Drivers

The LM5175-Q1 provides four N-channel MOSFET gate drivers: two floating high-side gate drivers at the HDRV1 and HDRV2 pins, and two ground referenced low-side drivers at the LDRV1 and LDRV2 pins. Each driver is capable of sourcing 1.5 A and sinking 2 A peak current. In buck operation, LDRV1 and HDRV1 are switched by the PWM controller while HDRV2 remains continuously on. In boost operation, LDRV2 and HDRV2 are switched while HDRV1 remains continuously on.

In DCM buck operation, LDRV1 and HDRV2 turn off when the inductor current drops to zero (diode emulation). In a DCM boost operation, HDRV2 turns off when inductor current drops to zero.

The gate drive output HDRV2 remains off during soft-start to prevent reverse current flow from a pre-biased output.

The low-side gate drivers are powered from VCC and the high-side gate drivers HDRV1 and HDRV2 are powered from bootstrap capacitors  $C_{BOOT1}$  (between BOOT1 and SW1) and  $C_{BOOT2}$  (between BOOT2 and SW2) respectively. The  $C_{BOOT1}$  and  $C_{BOOT2}$  capacitors are charged through external Schottky diodes connected to the VCC pin as shown in [Figure 24](#).

## Feature Description (continued)

### 8.3.14 Thermal Shutdown

The LM5175-Q1 is protected by a thermal shutdown circuit that shuts down the device when the internal junction temperature exceeds 165°C (typical). The soft-start capacitor is discharged when thermal shutdown is triggered and the gate drivers are disabled. The converter automatically restarts when the junction temperature drops by the thermal shutdown hysteresis of 15°C below the thermal shutdown threshold.

## 8.4 Device Functional Modes

Please refer to [Enable/UVLO](#) section for the description of EN/UVLO pin function. [Shutdown, Standby, and Operating Modes](#) section lists the shutdown, standby, and operating modes for LM5175-Q1 as a function of EN/UVLO and VCC voltages.

### 8.4.1 Shutdown, Standby, and Operating Modes

EN/UVLO	VCC	DEVICE MODE
EN/UVLO < 0.7 V	—	Shutdown: VCC off, No switching
0.7 V < EN/UVLO < 1.23 V	—	Standby: VCC on, No switching
EN/UVLO > 1.23 V	VCC < 3.3 V	Standby: VCC on, No switching
EN/UVLO > 1.23 V	VCC > 3.3 V	Operating: VCC on, Switching enabled

### 8.4.2 MODE Pin Configuration

The MODE pin is used to select CCM/DCM operation and hiccup mode current limit. Mode is latched at startup.

MODE PIN CONNECTION	LIGHT LOAD MODE	HICCUP FAULT PROTECTION
Connect to VCC	CCM	No Hiccup
RMODE to AGND = 93.1 kΩ	CCM	Hiccup Enabled
RMODE to AGND = 49.9 kΩ	DCM	Hiccup Enabled
Connect to AGND	DCM	No Hiccup

## 9 Application and Implementation

### NOTE

Information in the following applications sections is not part of the TI component specification, and TI does not warrant its accuracy or completeness. TI's customers are responsible for determining suitability of components for their purposes. Customers should validate and test their design implementation to confirm system functionality.

### 9.1 Application Information

The LM5175-Q1 is a four-switch buck-boost controller. A quick-start tool on the LM5175-Q1 product webpage can be used to design a buck-boost converter using the LM5175-Q1. Alternatively, Webench® software can create a complete buck-boost design using the LM5175-Q1 and generate bill of materials, estimate efficiency, solution size, and cost of the complete solution. The following sections describe a detailed step-by-step design procedure for a typical application circuit.

### 9.2 Typical Application

A typical application example is a buck-boost converter operating from a wide input voltage range of 6 V to 36 V and providing a stable 12 V output voltage with current capability of 6 A.

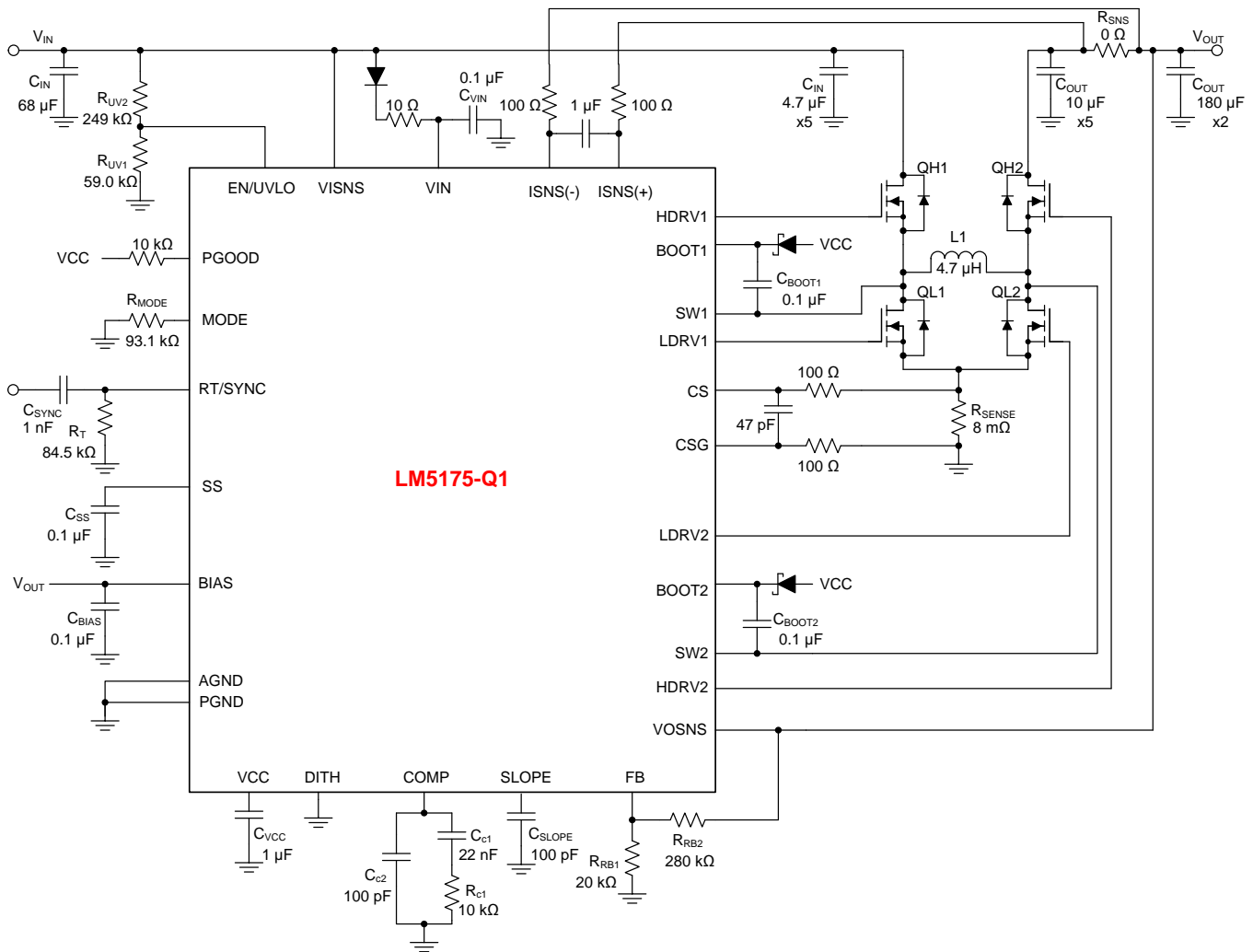

Copyright © 2016, Texas Instruments Incorporated

Figure 24. LM5175-Q1 Four-Switch Buck Boost Application Schematic

## Typical Application (continued)

### 9.2.1 Design Requirements

For this design example, the following are used as the input parameters.

DESIGN PARAMETER	EXAMPLE VALUE
Input Voltage Range	6 V to 36 V
Output	12 V
Load Current	6 A
Switching Frequency	300 kHz
Mode	CCM, Hiccup

### 9.2.2 Detailed Design Procedure

#### 9.2.2.1 Frequency

The switching frequency of LM5175-Q1 is set by an  $R_T$  resistor connected from RT/SYNC pin to AGND. The  $R_T$  resistor required to set the desired frequency is calculated using Equation 5 or Figure 3. A 1% standard resistor of 84.5 k $\Omega$  is selected for  $F_{sw} = 300$  kHz.

#### 9.2.2.2 $V_{OUT}$

The output voltage is set using a resistor divider to the FB pin. The internal reference voltage is 0.8 V. Normally the bottom resistor in the resistor divider is selected to be in the 1 k $\Omega$  to 100 k $\Omega$  range. Select

$$R_{FB1} = 20 \text{ k}\Omega \quad (11)$$

The top resistor in the feedback resistor divider is selected using Equation 12:

$$R_{FB2} = \frac{V_{OUT} - 0.8 \text{ V}}{0.8 \text{ V}} \times R_{FB1} = 280 \text{ k}\Omega \quad (12)$$

#### 9.2.2.3 Inductor Selection

The inductor selection is based on consideration of both buck and boost modes of operation. For the buck mode, inductor selection is based on limiting the peak to peak current ripple  $\Delta I_L$  to ~40% of the maximum inductor current at the maximum input voltage. The target inductance for the buck mode is:

$$L_{BUCK} = \frac{(V_{IN(MAX)} - V_{OUT}) \times V_{OUT}}{0.4 \times I_{OUT(MAX)} \times F_{sw} \times V_{IN(MAX)}} = 11.1 \mu\text{H} \quad (13)$$

For the boost mode, the inductor selection is based on limiting the peak to peak current ripple  $\Delta I_L$  to ~40% of the maximum inductor current at the minimum input voltage. The target inductance for the boost mode is:

$$L_{BOOST} = \frac{V_{IN(MIN)}^2 \times (V_{OUT} - V_{IN(MIN)})}{0.4 \times I_{OUT(MAX)} \times F_{sw} \times V_{OUT}^2} = 2.1 \mu\text{H} \quad (14)$$

In this particular application, the buck inductance is larger. Choosing a larger inductance reduces the ripple current but also increases the size of the inductor. A larger inductor also reduces the achievable bandwidth of the converter by moving the right half plane zero to lower frequencies. Therefore a judicious compromise should be made based on the application requirements. For this design a 4.7- $\mu\text{H}$  inductor is selected. With this inductor selection, the inductor current ripple is 5.7 A, 4.3 A, and 2.1 A, at  $V_{IN}$  of 36 V, 24 V, and 6 V respectively.

The maximum average inductor current occurs at the minimum input voltage and maximum load current:

$$I_{L(MAX)} = \frac{V_{OUT} \times I_{OUT(MAX)}}{0.9 \times V_{IN(MIN)}} = 13.3 \text{ A} \quad (15)$$

where a 90% efficiency is assumed. The peak inductor current occurs at minimum input voltage and is given by:

$$I_{L(PEAK)} = I_{L(MAX)} + \frac{V_{IN(MIN)} \times (V_{OUT} - V_{IN(MIN)})}{2 \times L1 \times F_{sw} \times V_{OUT}} = 14.4 \text{ A} \quad (16)$$

To ensure sufficient output current, the current limit threshold must be set to allow the maximum load current in boost operation. To ensure that the inductor does not saturate in current limit, the peak saturation current of the inductor should be higher than the maximum current limit. Adjusting for a  $\pm 20\%$  current limit threshold tolerance, the peak inductor current limit is:

$$I_{L(SAT)} = \frac{1.2 \times I_{L(PEAK)}}{0.8} = 21.6 \text{ A} \quad (17)$$

Therefore, the inductor saturation current should be greater than 21.6 A. If hiccup mode protection is not enabled, the RMS current rating of the inductor should be sufficient to tolerate continuous operation in cycle-by-cycle current limiting.

#### 9.2.2.4 Output Capacitor

In the boost mode, the output capacitor conducts high ripple current. The output capacitor RMS ripple current is given by Equation 18 where the minimum  $V_{IN}$  corresponds to the maximum capacitor current.

$$I_{COUT(RMS)} = I_{OUT} \times \sqrt{\frac{V_{OUT}}{V_{IN}} - 1} \quad (18)$$

In this example the maximum output ripple RMS current is  $I_{COUT(RMS)} = 6 \text{ A}$ . A 5-m $\Omega$  output capacitor ESR causes an output ripple voltage of 60 mV as given by:

$$\Delta V_{RIPPLE(ESR)} = \frac{I_{OUT} \times V_{OUT}}{V_{IN(MIN)}} \times ESR \quad (19)$$

A 400  $\mu\text{F}$  output capacitor causes a capacitive ripple voltage of 25 mV as given by:

$$\Delta V_{RIPPLE(COUT)} = \frac{I_{OUT} \times \left(1 - \frac{V_{IN(MIN)}}{V_{OUT}}\right)}{C_{OUT} \times F_{sw}} \quad (20)$$

Typically a combination of ceramic and bulk capacitors is needed to provide low ESR and high ripple current capacity. The complete schematic in Figure 24 at the end of this section shows a good starting point for  $C_{OUT}$  for typical applications.

#### 9.2.2.5 Input Capacitor

In the buck mode, the input capacitor supplies high ripple current. The RMS current in the input capacitor is given by:

$$I_{CIN(RMS)} = I_{OUT} \sqrt{D \times (1-D)} \quad (21)$$

The maximum RMS current occurs at  $D = 0.5$ , which gives  $I_{CIN(RMS)} = I_{OUT}/2 = 3 \text{ A}$ . A combination of ceramic and bulk capacitors should be used to provide short path for high di/dt current and to reduce the output voltage ripple. The complete schematic in Figure 24 is a good starting point for  $C_{IN}$  for typical applications.

#### 9.2.2.6 Sense Resistor ( $R_{SENSE}$ )

The current sense resistor between the CS and CSG pins should be selected to ensure that current limit is set high enough for both buck and boost modes of operation. For the buck operation, the current limit resistor is given by:

$$R_{SENSE(BUCK)} = \frac{76 \text{ mV} \times 70\%}{I_{OUT(MAX)}} = 8.8 \text{ m}\Omega \quad (22)$$

For the boost mode of operation, the current limit resistor is given by:

$$R_{SENSE(BOOST)} = \frac{160 \text{ mV} \times 70\%}{I_{L(PEAK)}} = 7.7 \text{ m}\Omega \quad (23)$$

The closest standard value of  $R_{SENSE} = 8 \text{ m}\Omega$  is selected based on the boost mode operation.

The maximum power dissipation in  $R_{\text{SENSE}}$  happens at  $V_{\text{IN(MIN)}}$ :

$$P_{\text{RSENSE(MAX)}} = \left( \frac{160 \text{ mV}}{R_{\text{SENSE}}} \right)^2 \cdot R_{\text{SENSE}} \cdot \left( 1 - \frac{V_{\text{IN(MIN)}}}{V_{\text{OUT}}} \right) = 1.7 \text{ W} \quad (24)$$

Based on this, select the current sense resistor with power rating of 2 W or higher.

For some application circuits, it may be required to add a filter network to attenuate noise in the CS and CSG sense lines. Please see [Figure 24](#) for typical values. The filter resistance should not exceed 100  $\Omega$ .

### 9.2.2.7 Slope Compensation

For stable current loop operation and to avoid sub-harmonic oscillations, the slope capacitor should be selected based on [Equation 25](#):

$$C_{\text{SLOPE}} = g_{\text{mSLOPE}} \times \frac{L_1}{R_{\text{SENSE}} \times A_{\text{CS}}} = 2 \mu\text{S} \times \frac{4.7 \mu\text{H}}{8 \text{ m}\Omega \times 5} = 235 \text{ pF} \quad (25)$$

This slope compensation results in “dead-beat” operation, in which the current loop disturbances die out in one switching cycle. Theoretically a current mode loop is stable with half the “dead-beat” slope (twice the calculated slope capacitor value in [Equation 25](#)). A smaller slope capacitor results in larger slope signal which is better for noise immunity in the transition region ( $V_{\text{IN}} \sim V_{\text{OUT}}$ ). A larger slope signal, however, restricts the achievable input voltage range for a given output voltage, switching frequency, and inductor. For this design  $C_{\text{SLOPE}} = 100 \text{ pF}$  is selected for better transition region behavior while still providing the required  $V_{\text{IN}}$  range. This selection of slope capacitor, inductor, switching frequency, and inductor satisfies the COMP range limitation explained in [Gm Error Amplifier](#) section.

### 9.2.2.8 UVLO

The UVLO resistor divider must be designed for turn-on below 6V. Selecting a  $R_{\text{UV2}} = 249 \text{ k}\Omega$  gives a UVLO hysteresis of 0.8 V. The lower UVLO resistor is the selected using [Equation 26](#):

$$R_{\text{UV1}} = \frac{R_{\text{UV2}} \times 1.23 \text{ V}}{V_{\text{IN(UV)}} + 1.5 \mu\text{A} \times R_{\text{UV2}} - 1.23 \text{ V}} = 59.5 \text{ k}\Omega \quad (26)$$

A standard value of 59.0 k $\Omega$  is selected for  $R_{\text{UV1}}$ .

When programming the UVLO threshold for lower input voltage operation, it is important to choose MOSFETs with gate (Miller) plateau voltage lower than the minimum  $V_{\text{IN}}$ .

### 9.2.2.9 Soft-Start Capacitor

The soft-start time is programmed using the soft-start capacitor. The relationship between  $C_{\text{SS}}$  and the soft-start time is given by:

$$t_{\text{SS}} = \frac{0.8 \text{ V} \times C_{\text{SS}}}{5 \mu\text{A}} \quad (27)$$

$C_{\text{SS}} = 0.1 \mu\text{F}$  gives a soft-start time of 16 ms.

### 9.2.2.10 Dither Capacitor

The dither capacitor sets the modulation frequency of the frequency dithering around the nominal switching frequency. A larger  $C_{\text{DITH}}$  results in lower modulation frequency. For proper operation the modulation frequency ( $F_{\text{MOD}}$ ) must be much lower than the switching frequency. Use [Equation 28](#) to select  $C_{\text{DITH}}$  for the target modulation frequency.

$$C_{\text{DITH}} = \frac{10 \mu\text{A}}{F_{\text{MOD}} \times 0.24 \text{ V}} \quad (28)$$

For the current design dithering is not being implemented. Therefore a 0  $\Omega$  resistor from the DITH pin to AGND disables this feature.

### 9.2.2.11 MOSFETs QH1 and QL1

The input side MOSFETs QH1 and QL1 need to withstand the maximum input voltage of 36 V. In addition they must withstand the transient spikes at SW1 during switching. Therefore QH1 and QL1 should be rated for 60 V. The gate plateau voltages of the MOSFETs should be smaller than the minimum input voltage of the converter, otherwise the MOSFETs may not fully enhance during startup or overload conditions.

The power loss in QH1 in the boost mode of operation is approximated by:

$$P_{\text{COND}(QH1)} = \left( I_{\text{OUT}} \cdot \frac{V_{\text{OUT}}}{V_{\text{IN}}} \right)^2 \cdot R_{\text{DSON}(QH1)} \quad (29)$$

The power loss in QH1 in the buck mode of operation consists of both conduction and switching loss components given by Equation 30 and Equation 31 respectively:

$$P_{\text{COND}(QH1)} = \left( \frac{V_{\text{OUT}}}{V_{\text{IN}}} \right) \cdot I_{\text{OUT}}^2 \cdot R_{\text{DSON}(QH1)} \quad (30)$$

$$P_{\text{SW}(QH1)} = \frac{1}{2} \cdot V_{\text{IN}} \cdot I_{\text{OUT}} \cdot (t_r + t_f) \cdot F_{\text{sw}} \quad (31)$$

The rise ( $t_r$ ) and the fall ( $t_f$ ) times are based on the MOSFET datasheet information or measured in the lab. Typically a MOSFET with smaller  $R_{\text{DSON}}$  (smaller conduction loss) will have longer rise and fall times (larger switching loss).

The power loss in QL1 in the buck mode of operation is given by the following equation:

$$P_{\text{COND}(QL1)} = \left( 1 - \frac{V_{\text{OUT}}}{V_{\text{IN}}} \right) \cdot I_{\text{OUT}}^2 \cdot R_{\text{DSON}(QL1)} \quad (32)$$

### 9.2.2.12 MOSFETs QH2 and QL2

The output side MOSFETs QH2 and QL2 see the output voltage of 12 V and additional transient spikes at SW2 during switching. Therefore QH2 and QL2 should be rated for 20 V or more. The gate plateau voltages of the MOSFETs should be smaller than the minimum input voltage of the converter, otherwise the MOSFETs may not fully enhance during startup or overload conditions.

The power loss in QH2 in the buck mode of operation is approximated by:

$$P_{\text{COND}(QH2)} = I_{\text{OUT}}^2 \cdot R_{\text{DSON}(QH2)} \quad (33)$$

The power loss in QL2 in the boost mode of operation consists of both conduction and switching loss components given by Equation 34 and Equation 35 respectively:

$$P_{\text{COND}(QL2)} = \left( 1 - \frac{V_{\text{IN}}}{V_{\text{OUT}}} \right) \cdot \left( I_{\text{OUT}} \cdot \frac{V_{\text{OUT}}}{V_{\text{IN}}} \right)^2 \cdot R_{\text{DSON}(QL2)} \quad (34)$$

$$P_{\text{SW}(QL2)} = \frac{1}{2} \cdot V_{\text{OUT}} \cdot \left( I_{\text{OUT}} \cdot \frac{V_{\text{OUT}}}{V_{\text{IN}}} \right) \cdot (t_r + t_f) \cdot F_{\text{sw}} \quad (35)$$

The rise ( $t_r$ ) and the fall ( $t_f$ ) times can be based on the MOSFET datasheet information or measured in the lab. Typically a MOSFET with smaller  $R_{\text{DSON}}$  (lower conduction loss) has longer rise and fall times (larger switching loss).

The power loss in QH2 in the boost mode of operation is given by the following equation:

$$P_{\text{COND}(QH2)} = \frac{V_{\text{IN}}}{V_{\text{OUT}}} \cdot \left( I_{\text{OUT}} \cdot \frac{V_{\text{OUT}}}{V_{\text{IN}}} \right)^2 \cdot R_{\text{DSON}(QH2)} \quad (36)$$

### 9.2.2.13 Frequency Compensation

This section presents the control loop compensation design procedure for the LM5175-Q1 buck-boost controller. The LM5175-Q1 operates mainly in buck or boost modes, separated by a transition region, and therefore the control loop design is done for both buck and boost operating modes. Then a final selection of compensation is made based on the mode that is more restrictive from a loop stability point of view. Typically for a converter designed to go deep into both buck and boost operating regions, the boost compensation design is more restrictive due to the presence of a right half plane zero (RHPZ) in the boost mode.

The boost power stage output pole location is given by:

$$f_{p1(\text{boost})} = \frac{1}{2\pi} \left( \frac{2}{R_{\text{OUT}} \times C_{\text{OUT}}} \right) = 398 \text{ Hz} \quad (37)$$

where  $R_{\text{OUT}} = 2 \Omega$  corresponds to the maximum load of 6 A.

The boost power stage ESR zero location is given by:

$$f_{z1} = \frac{1}{2\pi} \left( \frac{1}{R_{\text{ESR}} \times C_{\text{OUT}}} \right) = 79.6 \text{ kHz} \quad (38)$$

The boost power stage RHP zero location is given by:

$$f_{\text{RHP}} = \frac{1}{2\pi} \left( \frac{R_{\text{OUT}} \times (1 - D_{\text{MAX}})^2}{L1} \right) = 16.9 \text{ kHz} \quad (39)$$

where  $D_{\text{MAX}}$  is the maximum duty cycle at the minimum  $V_{\text{IN}}$ .

The buck power stage output pole location is given by:

$$f_{p1(\text{buck})} = \frac{1}{2\pi} \left( \frac{1}{R_{\text{OUT}} \times C_{\text{OUT}}} \right) = 199 \text{ Hz} \quad (40)$$

The buck power stage ESR zero location is the same as the boost power stage ESR zero.

It is clear from [Equation 39](#) that RHP zero is the main factor limiting the achievable bandwidth. For a robust design the crossover frequency should be less than 1/3 of the RHP zero frequency. Given the position of the RHP zero, a reasonable target bandwidth in boost operation is around 4 kHz:

$$f_{\text{bw}} = 4 \text{ kHz} \quad (41)$$

For some power stages, the boost RHP zero might not be as restrictive. This happens when the boost maximum duty cycle ( $D_{\text{MAX}}$ ) is small, or when a really small inductor is used. In those cases, compare the limits posed by the RHP zero ( $f_{\text{RHP}}/3$ ) with 1/20 of the switching frequency and use the smaller of the two values as the achievable bandwidth.

The compensation zero can be placed at 1.5 times the boost output pole frequency. Keep in mind that this locates the zero at 3 times the buck output pole frequency which results in approximately 30 degrees of phase loss before crossover of the buck loop and 15 degrees of phase loss at intermediate frequencies for the boost loop:

$$f_{\text{zc}} = 600 \text{ Hz} \quad (42)$$

If the crossover frequency is well below the RHP zero and the compensation zero is placed well below the crossover, the compensation gain resistor  $R_{\text{c1}}$  is calculated using the approximation:

$$R_{\text{c1}} = \frac{2\pi \times f_{\text{bw}}}{g_{\text{mEA}}} \times \frac{R_{\text{FB1}} + R_{\text{FB2}}}{R_{\text{FB1}}} \times \frac{A_{\text{CS}} \times R_{\text{SENSE}} \times C_{\text{OUT}}}{1 - D_{\text{MAX}}} = 9.49 \text{ k}\Omega \quad (43)$$

where  $D_{\text{MAX}}$  is the maximum duty cycle at the minimum  $V_{\text{IN}}$  in boost mode and  $A_{\text{CS}}$  is the current sense amplifier gain. The compensation capacitor  $C_{\text{c1}}$  is then calculated from:

$$C_{\text{c1}} = \frac{1}{2 \times \pi \times f_{\text{zc}} \times R_{\text{c1}}} = 27.9 \text{ nF} \quad (44)$$

The standard values of compensation components are selected to be  $R_{\text{c1}} = 10 \text{ k}\Omega$  and  $C_{\text{c1}} = 22 \text{ nF}$ .

A high frequency pole is added to suppress switching noise using a 100 pF capacitor ( $C_{c2}$ ) in parallel with  $R_{c1}$  and  $C_{c1}$ . These values provide a good starting point for the compensation design. Each design should be tuned in the lab to achieve the desired balance between stability margin across the operating range and transient response time.

### 9.2.3 Application Curves

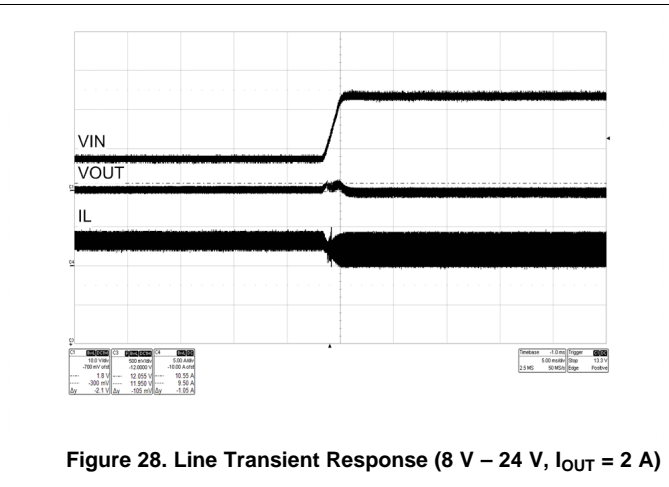
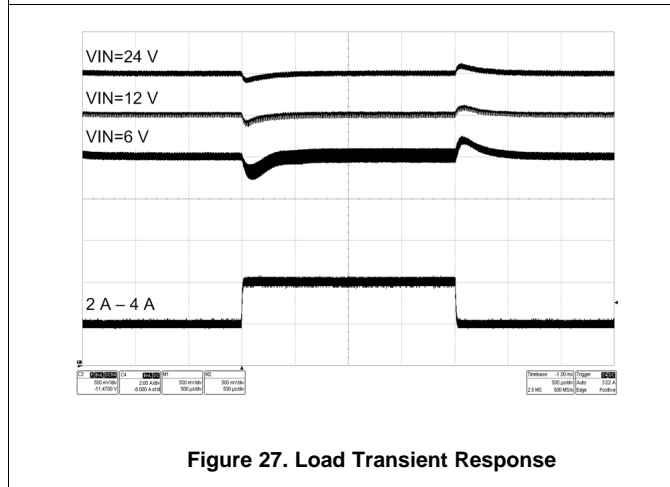
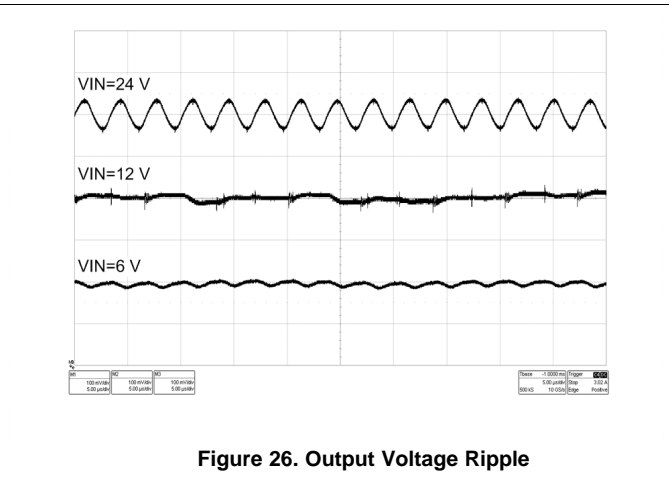
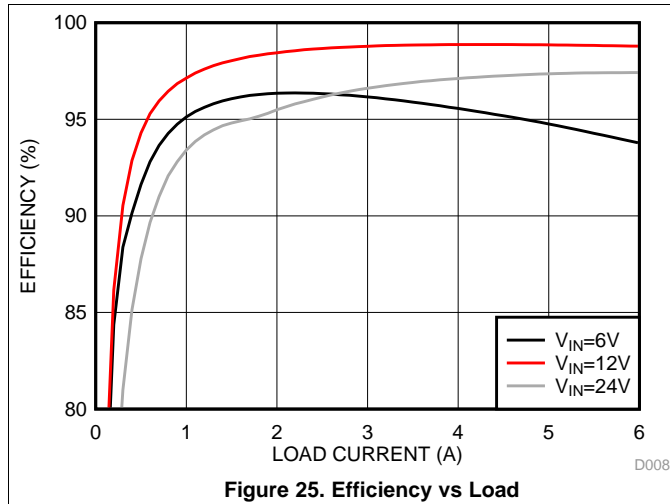

## 10 Power Supply Recommendations

The LM5175-Q1 is a power management device. The power supply for the device is any dc voltage source within the specified input range. The supply should also be capable of supplying sufficient current based on the maximum inductor current in boost mode operation. The input supply should be bypassed with additional electrolytic capacitor at the input of the application board to avoid ringing due to parasitic impedance of the connecting cables.

## 11 Layout

### 11.1 Layout Guidelines

The basic PCB board layout requires separation of sensitive signal and power paths. The following checklist should be followed to get good performance for a well designed board.

- Place the power components including the input filter capacitor  $C_{IN}$ , the power MOSFETs QL1 and QH1, and the sense resistor  $R_{SENSE}$  close together to minimize the loop area for input switching current in buck operation.
- Place the power components including the output filter capacitor  $C_{OUT}$ , the power MOSFETs QL2 and QH2, and the sense resistor  $R_{SENSE}$  close together to minimize the loop area for output switching current in boost operation.
- Use a combination of bulk capacitors and smaller ceramic capacitors with low series impedance for the input and output capacitors. Place the smaller capacitors closer to the IC to provide a low impedance path for high di/dt switching currents.
- Minimize the SW1 and SW2 loop areas as these are high dv/dt nodes.
- Layout the gate drive traces and return paths as directly as possible. Layout the forward and return traces close together, either running side by side or on top of each other on adjacent layers to minimize the inductance of the gate drive path.
- Use Kelvin connections to  $R_{SENSE}$  for the current sense signals CS and CSG and run lines in parallel from the  $R_{SENSE}$  terminals to the IC pins. Avoid crossing noisy areas such as SW1 and SW2 nodes or high-side gate drive traces. Place the filter capacitor for the current sense signal as close to the IC pins as possible.
- Place the  $C_{IN}$ ,  $C_{OUT}$ , and  $R_{SENSE}$  ground pins as close as possible with thick ground trace and/or planes on multiple layers.
- Place the VCC bypass capacitor close to the controller IC, between the VCC and PGND pins. A 1- $\mu$ F ceramic capacitor is typically used.
- Place the BIAS bypass capacitor close to the controller IC, between the BIAS and PGND pins. A 0.1- $\mu$ F ceramic capacitor is typically used.
- Place the BOOT1 bootstrap capacitor close to the IC and connect directly to the BOOT1 to SW1 pins.
- Place the BOOT2 bootstrap capacitor close to the IC and connect directly to the BOOT2 to SW2 pins.
- Bypass the  $V_{IN}$  pin to AGND with a low ESR ceramic capacitor located close to the controller IC. A 0.1  $\mu$ F ceramic capacitor is typically used. When using external BIAS, use a diode between input rails and  $V_{IN}$  pins to prevent reverse conduction when  $V_{IN} < V_{CC}$ .
- Connect the feedback resistor divider between the  $C_{OUT}$  positive terminal and AGND pin of the IC. Place the components close to the FB pin.
- Use care to separate the power and signal paths so that no power or switching current flows through the AGND connections which can either corrupt the COMP, SLOPE, or SYNC signals, or cause dc offset in the FB sense signal. The PGND and AGND traces can be connected near the PGND pin, near the VCC capacitor PGND connection, or near the PGND connection of the CS, CSG pin current sense resistor.
- When using the average current loop, divide the overall capacitor ( $C_{IN}$  or  $C_{OUT}$ ) between the two sides of the sense resistor to ensure small cycle-by-cycle ripple. Place the average current loop filter capacitor close to the IC between the ISNS(+) and ISNS(-) pins.

## 11.2 Layout Example

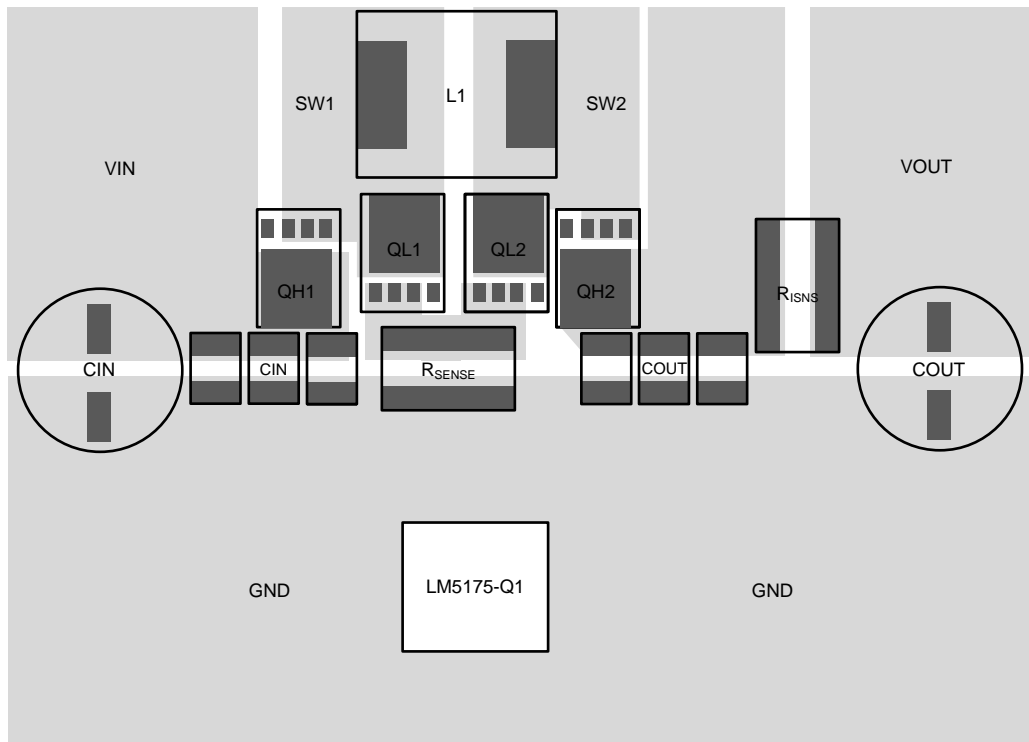

Figure 29. LM5175-Q1 Power Stage Layout

## 12 器件和文档支持

### 12.1 文档支持

#### 12.1.1 相关文档

请访问德州仪器 (TI) 主页以获取最新技术文档，包括应用笔记、用户指南和参考设计。

应用报告《IC 封装热指标》，[SPRA953](#)。

### 12.2 社区资源

The following links connect to TI community resources. Linked contents are provided "AS IS" by the respective contributors. They do not constitute TI specifications and do not necessarily reflect TI's views; see TI's [Terms of Use](#).

**TI E2E™ Online Community** *TI's Engineer-to-Engineer (E2E) Community*. Created to foster collaboration among engineers. At [e2e.ti.com](http://e2e.ti.com), you can ask questions, share knowledge, explore ideas and help solve problems with fellow engineers.

**Design Support** *TI's Design Support* Quickly find helpful E2E forums along with design support tools and contact information for technical support.

### 12.3 商标

PowerPAD, E2E are trademarks of Texas Instruments.  
Webench is a registered trademark of Texas Instruments.  
All other trademarks are the property of their respective owners.

### 12.4 静电放电警告



这些装置包含有限的内置 ESD 保护。存储或装卸时，应将导线一起截短或将装置放置于导电泡棉中，以防止 MOS 门极遭受静电损伤。

### 12.5 Glossary

[SLYZ022](#) — *TI Glossary*.

This glossary lists and explains terms, acronyms, and definitions.

## 13 机械、封装和可订购信息

以下页中包括机械、封装和可订购信息。这些信息是针对指定器件可提供的最新数据。这些数据会在无通知且不对本文档进行修订的情况下发生改变。欲获得该数据表的浏览器版本，请查阅左侧的导航栏。

## 13.1 Package Option Addendum

### 13.1.1 Packaging Information

Orderable Device	Status <sup>(1)</sup>	Package Type	Package Drawing	Pins	Package Qty	Eco Plan <sup>(2)</sup>	Lead/Ball Finish	MSL Peak Temp <sup>(3)</sup>	Op Temp (°C)	Device Marking <sup>(4)(5)</sup>
LM5175QPWRQ1	PREVIEW	HTSSOP	PWP	28	2000	Green (RoHS & no Sb/Br)	CU NIPDAU	Level-3-260C-168 HR	-40 to 125	LM5175Q
LM5175QPWPTQ1	PREVIEW	HTSSOP	PWP	28	250	Green (RoHS & no Sb/Br)	CU NIPDAU	Level-3-260C-168 HR	-40 to 125	LM5175Q

- (1) The marketing status values are defined as follows:  
**ACTIVE:** Product device recommended for new designs.  
**LIFEBUY:** TI has announced that the device will be discontinued, and a lifetime-buy period is in effect.  
**NRND:** Not recommended for new designs. Device is in production to support existing customers, but TI does not recommend using this part in a new design.  
**PRE\_PROD** Unannounced device, not in production, not available for mass market, nor on the web, samples not available.  
**PREVIEW:** Device has been announced but is not in production. Samples may or may not be available.  
**OBSOLETE:** TI has discontinued the production of the device.
- (2) Eco Plan - The planned eco-friendly classification: Pb-Free (RoHS), Pb-Free (RoHS Exempt), or Green (RoHS & no Sb/Br) - please check <http://www.ti.com/productcontent> for the latest availability information and additional product content details.  
**TBD:** The Pb-Free/Green conversion plan has not been defined.  
**Pb-Free (RoHS):** TI's terms "Lead-Free" or "Pb-Free" mean semiconductor products that are compatible with the current RoHS requirements for all 6 substances, including the requirement that lead not exceed 0.1% by weight in homogeneous materials. Where designed to be soldered at high temperatures, TI Pb-Free products are suitable for use in specified lead-free processes.  
**Pb-Free (RoHS Exempt):** This component has a RoHS exemption for either 1) lead-based flip-chip solder bumps used between the die and package, or 2) lead-based die adhesive used between the die and leadframe. The component is otherwise considered Pb-Free (RoHS compatible) as defined above.  
**Green (RoHS & no Sb/Br):** TI defines "Green" to mean Pb-Free (RoHS compatible), and free of Bromine (Br) and Antimony (Sb) based flame retardants (Br or Sb do not exceed 0.1% by weight in homogeneous material)
- (3) MSL, Peak Temp. -- The Moisture Sensitivity Level rating according to the JEDEC industry standard classifications, and peak solder temperature.
- (4) There may be additional marking, which relates to the logo, the lot trace code information, or the environmental category on the device
- (5) Multiple Device markings will be inside parentheses. Only on Device Marking contained in parentheses and separated by a "-" will appear on a device. If a line is indented then it is a continuation of the previous line and the two combined represent the entire Device Marking for that device.

**Important Information and Disclaimer:** The information provided on this page represents TI's knowledge and belief as of the date that it is provided. TI bases its knowledge and belief on information provided by third parties, and makes no representation or warranty as to the accuracy of such information. Efforts are underway to better integrate information from third parties. TI has taken and continues to take reasonable steps to provide representative and accurate information but may not have conducted destructive testing or chemical analysis on incoming materials and chemicals. TI and TI suppliers consider certain information to be proprietary, and thus CAS numbers and other limited information may not be available for release.

In no event shall TI's liability arising out of such information exceed the total purchase price of the TI part(s) at issue in this document sold by TI to Customer on an annual basis.

## 重要声明

德州仪器(TI)及其下属子公司有权根据 JESD46 最新标准,对所提供的产品和服务进行更正、修改、增强、改进或其它更改,并有权根据 JESD48 最新标准中止提供任何产品和服务。客户在下订单前应获取最新的相关信息,并验证这些信息是否完整且是最新的。所有产品的销售都遵循在订单确认时所提供的TI 销售条款与条件。

TI 保证其所销售的组件的性能符合产品销售时 TI 半导体产品销售条件与条款的适用规范。仅在 TI 保证的范围内,且 TI 认为有必要时才会使用测试或其它质量控制技术。除非适用法律做出了硬性规定,否则没有必要对每种组件的所有参数进行测试。

TI 对应用帮助或客户产品设计不承担任何义务。客户应对其使用 TI 组件的产品和应用自行负责。为尽量减小与客户产品和应用相关的风险,客户应提供充分的设计与操作安全措施。

TI 不对任何 TI 专利权、版权、屏蔽作品权或其它与使用了 TI 组件或服务的组合设备、机器或流程相关的 TI 知识产权中授予的直接或隐含权限作出任何保证或解释。TI 所发布的与第三方产品或服务有关的信息,不能构成从 TI 获得使用这些产品或服务的许可、授权、或认可。使用此类信息可能需要获得第三方的专利权或其它知识产权方面的许可,或是 TI 的专利权或其它知识产权方面的许可。

对于 TI 的产品手册或数据表中 TI 信息的重要部分,仅在没有对内容进行任何篡改且带有相关授权、条件、限制和声明的情况下才允许进行复制。TI 对此类篡改过的文件不承担任何责任或义务。复制第三方的信息可能需要服从额外的限制条件。

在转售 TI 组件或服务时,如果对该组件或服务参数的陈述与 TI 标明的参数相比存在差异或虚假成分,则会失去相关 TI 组件或服务的所有明示或暗示授权,且这是不正当的、欺诈性商业行为。TI 对任何此类虚假陈述均不承担任何责任或义务。

客户认可并同意,尽管任何应用相关信息或支持仍可能由 TI 提供,但他们将独立负责满足与其产品及其在应用中使用的 TI 产品相关的所有法律、法规和安全相关要求。客户声明并同意,他们具备制定与实施安全措施所需的全部专业技术和知识,可预见故障的危险后果、监测故障及其后果、降低有可能造成人身伤害的故障的发生机率并采取适当的补救措施。客户将全额赔偿因在此类安全关键应用中使用任何 TI 组件而对 TI 及其代理造成的任何损失。

在某些场合中,为了推进安全相关应用有可能对 TI 组件进行特别的促销。TI 的目标是利用此类组件帮助客户设计和创立其特有的可满足适用的功能安全性标准和要求的终端产品解决方案。尽管如此,此类组件仍然服从这些条款。

TI 组件未获得用于 FDA Class III (或类似的生命攸关医疗设备)的授权许可,除非各方授权官员已经达成了专门管控此类使用的特别协议。

只有那些 TI 特别注明属于军用等级或“增强型塑料”的 TI 组件才是设计或专门用于军事/航空应用或环境的。购买者认可并同意,对并非指定面向军事或航空航天用途的 TI 组件进行军事或航空航天方面的应用,其风险由客户单独承担,并且由客户独立负责满足与此类使用相关的所有法律和法规要求。

TI 已明确指定符合 ISO/TS16949 要求的产品,这些产品主要用于汽车。在任何情况下,因使用非指定产品而无法达到 ISO/TS16949 要求, TI 不承担任何责任。

	产品		应用
数字音频	<a href="http://www.ti.com.cn/audio">www.ti.com.cn/audio</a>	通信与电信	<a href="http://www.ti.com.cn/telecom">www.ti.com.cn/telecom</a>
放大器和线性器件	<a href="http://www.ti.com.cn/amplifiers">www.ti.com.cn/amplifiers</a>	计算机及周边	<a href="http://www.ti.com.cn/computer">www.ti.com.cn/computer</a>
数据转换器	<a href="http://www.ti.com.cn/dataconverters">www.ti.com.cn/dataconverters</a>	消费电子	<a href="http://www.ti.com.cn/consumer-apps">www.ti.com.cn/consumer-apps</a>
DLP® 产品	<a href="http://www.dlp.com">www.dlp.com</a>	能源	<a href="http://www.ti.com.cn/energy">www.ti.com.cn/energy</a>
DSP - 数字信号处理器	<a href="http://www.ti.com.cn/dsp">www.ti.com.cn/dsp</a>	工业应用	<a href="http://www.ti.com.cn/industrial">www.ti.com.cn/industrial</a>
时钟和计时器	<a href="http://www.ti.com.cn/clockandtimers">www.ti.com.cn/clockandtimers</a>	医疗电子	<a href="http://www.ti.com.cn/medical">www.ti.com.cn/medical</a>
接口	<a href="http://www.ti.com.cn/interface">www.ti.com.cn/interface</a>	安防应用	<a href="http://www.ti.com.cn/security">www.ti.com.cn/security</a>
逻辑	<a href="http://www.ti.com.cn/logic">www.ti.com.cn/logic</a>	汽车电子	<a href="http://www.ti.com.cn/automotive">www.ti.com.cn/automotive</a>
电源管理	<a href="http://www.ti.com.cn/power">www.ti.com.cn/power</a>	视频和影像	<a href="http://www.ti.com.cn/video">www.ti.com.cn/video</a>
微控制器 (MCU)	<a href="http://www.ti.com.cn/microcontrollers">www.ti.com.cn/microcontrollers</a>		
RFID 系统	<a href="http://www.ti.com.cn/rfidsys">www.ti.com.cn/rfidsys</a>		
OMAP应用处理器	<a href="http://www.ti.com/omap">www.ti.com/omap</a>		
无线连通性	<a href="http://www.ti.com.cn/wirelessconnectivity">www.ti.com.cn/wirelessconnectivity</a>	德州仪器在线技术支持社区	<a href="http://www.deyisupport.com">www.deyisupport.com</a>

邮寄地址: 上海市浦东新区世纪大道1568号, 中建大厦32楼邮政编码: 200122  
Copyright © 2016, 德州仪器半导体技术(上海)有限公司

**PACKAGING INFORMATION**

Orderable Device	Status (1)	Package Type	Package Drawing	Pins	Package Qty	Eco Plan (2)	Lead finish/ Ball material (6)	MSL Peak Temp (3)	Op Temp (°C)	Device Marking (4/5)	Samples
LM5175QPWPRQ1	ACTIVE	HTSSOP	PWP	28	2000	RoHS & Green	NIPDAU	Level-3-260C-168 HR	-40 to 125	LM5175Q	<a href="#">Samples</a>
LM5175QPWPTQ1	ACTIVE	HTSSOP	PWP	28	250	RoHS & Green	NIPDAU	Level-3-260C-168 HR	-40 to 125	LM5175Q	<a href="#">Samples</a>

(1) The marketing status values are defined as follows:

**ACTIVE:** Product device recommended for new designs.

**LIFEBUY:** TI has announced that the device will be discontinued, and a lifetime-buy period is in effect.

**NRND:** Not recommended for new designs. Device is in production to support existing customers, but TI does not recommend using this part in a new design.

**PREVIEW:** Device has been announced but is not in production. Samples may or may not be available.

**OBSOLETE:** TI has discontinued the production of the device.

(2) **RoHS:** TI defines "RoHS" to mean semiconductor products that are compliant with the current EU RoHS requirements for all 10 RoHS substances, including the requirement that RoHS substance do not exceed 0.1% by weight in homogeneous materials. Where designed to be soldered at high temperatures, "RoHS" products are suitable for use in specified lead-free processes. TI may reference these types of products as "Pb-Free".

**RoHS Exempt:** TI defines "RoHS Exempt" to mean products that contain lead but are compliant with EU RoHS pursuant to a specific EU RoHS exemption.

**Green:** TI defines "Green" to mean the content of Chlorine (Cl) and Bromine (Br) based flame retardants meet JS709B low halogen requirements of <=1000ppm threshold. Antimony trioxide based flame retardants must also meet the <=1000ppm threshold requirement.

(3) MSL, Peak Temp. - The Moisture Sensitivity Level rating according to the JEDEC industry standard classifications, and peak solder temperature.

(4) There may be additional marking, which relates to the logo, the lot trace code information, or the environmental category on the device.

(5) Multiple Device Markings will be inside parentheses. Only one Device Marking contained in parentheses and separated by a "~" will appear on a device. If a line is indented then it is a continuation of the previous line and the two combined represent the entire Device Marking for that device.

(6) Lead finish/Ball material - Orderable Devices may have multiple material finish options. Finish options are separated by a vertical ruled line. Lead finish/Ball material values may wrap to two lines if the finish value exceeds the maximum column width.

**Important Information and Disclaimer:**The information provided on this page represents TI's knowledge and belief as of the date that it is provided. TI bases its knowledge and belief on information provided by third parties, and makes no representation or warranty as to the accuracy of such information. Efforts are underway to better integrate information from third parties. TI has taken and continues to take reasonable steps to provide representative and accurate information but may not have conducted destructive testing or chemical analysis on incoming materials and chemicals. TI and TI suppliers consider certain information to be proprietary, and thus CAS numbers and other limited information may not be available for release.

In no event shall TI's liability arising out of such information exceed the total purchase price of the TI part(s) at issue in this document sold by TI to Customer on an annual basis.





# EXAMPLE BOARD LAYOUT

PWP0028C

PowerPAD™ TSSOP - 1.2 mm max height

SMALL OUTLINE PACKAGE

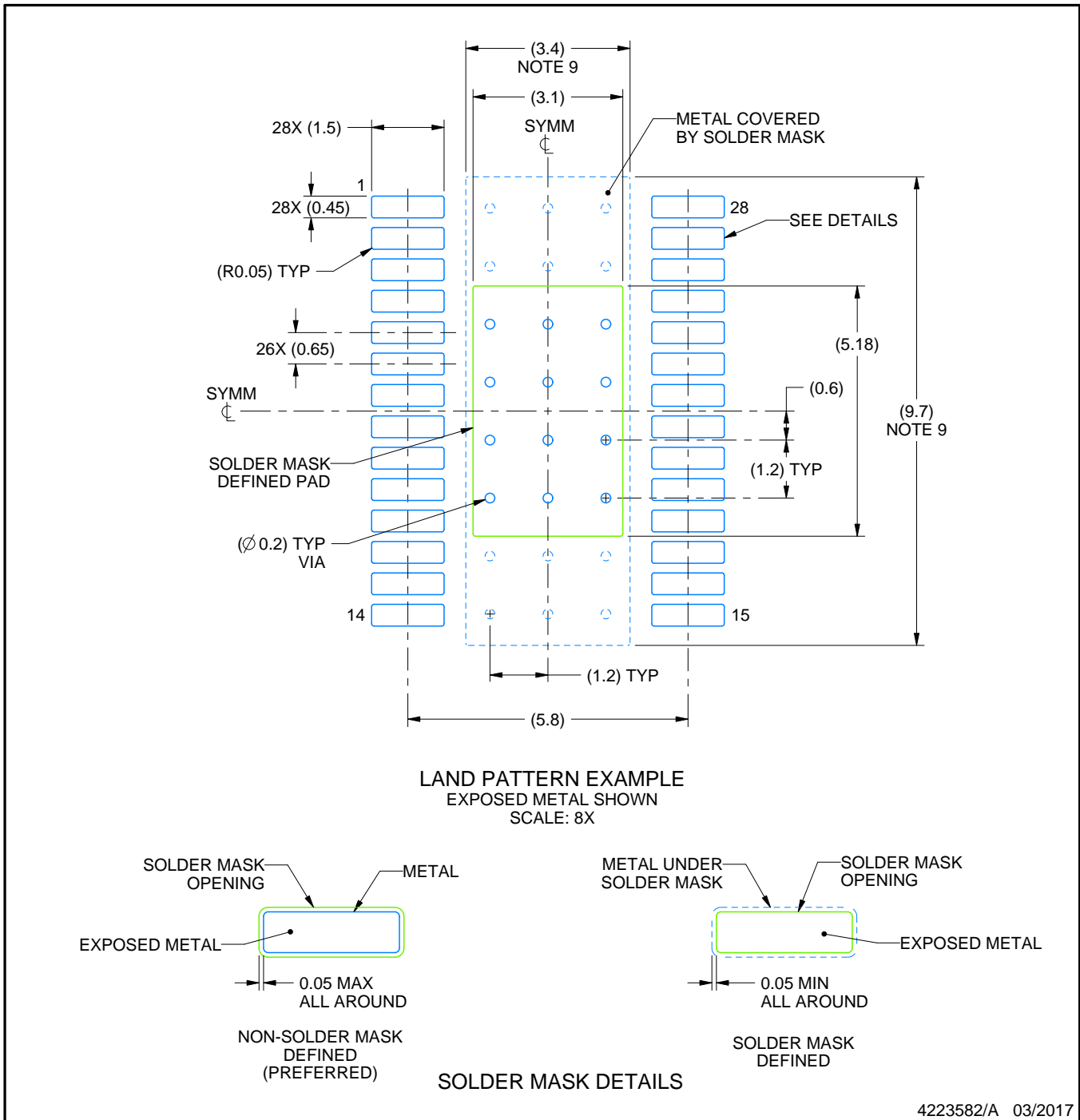

NOTES: (continued)

6. Publication IPC-7351 may have alternate designs.
7. Solder mask tolerances between and around signal pads can vary based on board fabrication site.
8. This package is designed to be soldered to a thermal pad on the board. For more information, see Texas Instruments literature numbers SLMA002 ([www.ti.com/lit/slma002](http://www.ti.com/lit/slma002)) and SLMA004 ([www.ti.com/lit/slma004](http://www.ti.com/lit/slma004)).
9. Size of metal pad may vary due to creepage requirement.
10. Vias are optional depending on application, refer to device data sheet. It is recommended that vias under paste be filled, plugged or tented.

# EXAMPLE STENCIL DESIGN

PWP0028C

PowerPAD™ TSSOP - 1.2 mm max height

SMALL OUTLINE PACKAGE

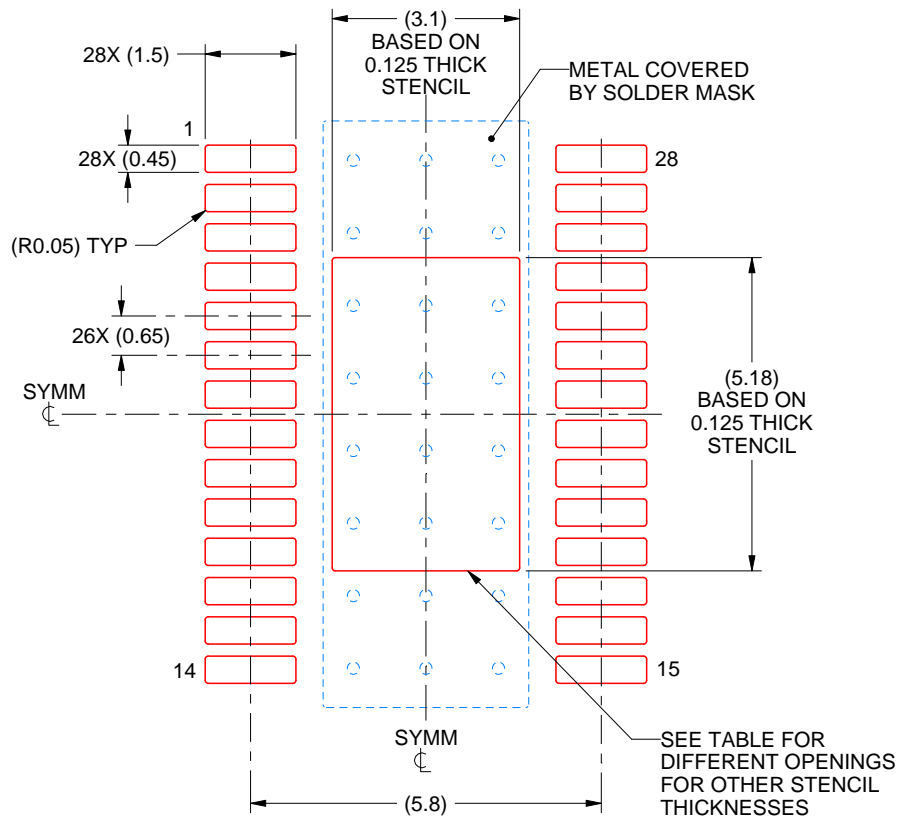

**SOLDER PASTE EXAMPLE**  
 BASED ON 0.125 mm THICK STENCIL  
 SCALE: 8X

STENCIL THICKNESS	SOLDER STENCIL OPENING
0.1	3.47 X 5.79
0.125	3.10 X 5.18 (SHOWN)
0.15	2.83 X 4.73
0.175	2.62 X 4.38

4223582/A 03/2017

NOTES: (continued)

11. Laser cutting apertures with trapezoidal walls and rounded corners may offer better paste release. IPC-7525 may have alternate design recommendations.
12. Board assembly site may have different recommendations for stencil design.

## 重要声明和免责声明

TI 均以“原样”提供技术性及其可靠性数据（包括数据表）、设计资源（包括参考设计）、应用或其他设计建议、网络工具、安全信息和其他资源，不保证其中不含任何瑕疵，且不做任何明示或暗示的担保，包括但不限于对适销性、适合某特定用途或不侵犯任何第三方知识产权的暗示担保。

所述资源可供专业开发人员应用TI 产品进行设计使用。您将对以下行为独自承担全部责任：(1) 针对您的应用选择合适的TI 产品；(2) 设计、验证并测试您的应用；(3) 确保您的应用满足相应标准以及任何其他安全、安保或其他要求。所述资源如有变更，恕不另行通知。TI 对您使用所述资源的授权仅限于开发资源所涉及TI 产品的相关应用。除此之外不得复制或展示所述资源，也不提供其它TI 或任何第三方的知识产权授权许可。如因使用所述资源而产生任何索赔、赔偿、成本、损失及债务等，TI 对此概不负责，并且您须赔偿由此对TI 及其代表造成的损害。

TI 所提供产品均受TI 的销售条款 (<http://www.ti.com.cn/zh-cn/legal/termsofsale.html>) 以及ti.com.cn上或随附TI产品提供的其他可适用条款的约束。TI提供所述资源并不扩展或以其他方式更改TI 针对TI 产品所发布的可适用的担保范围或担保免责声明。

邮寄地址：上海市浦东新区世纪大道 1568 号中建大厦 32 楼，邮政编码：200122

Copyright © 2020 德州仪器半导体技术（上海）有限公司