

TPS53317A 用于 DDR 存储器终端的 6A 输出、D-CAP+ 模式、同步降压集成 FET 转换器

1 特性

- 采用 TI 专有的集成金属氧化物半导体场效应晶体管 (MOSFET) 和封装技术
- 支持 DDR 内存终止，具有高达 6A 的持续输出源电流或者吸收电流
- 外部跟踪
- 最少的外部组件数
- 0.9V 至 6V 转换电压
- D-CAP+™ 模式架构
- 支持所有多层片式陶瓷输出电容器和 SP/POSCAP
- 可选跳跃 (SKIP) 模式或者强制 CCM
- 轻量级负载与重负载下的优化效率
- 可选 600kHz 或者 1MHz 开关频率
- 可选过流限制 (OCL)
- 过压、过温和断续欠压保护
- 可调输出电压范围为 0.45V 至 2V
- 3.5mm × 4mm 20 引脚超薄四方扁平无引线 (VQFN) 封装

2 应用

- 用于 DDR、DDR2、DDR3 和 DDR4 的存储器终端稳压器
- VTT 终止
- 用于 0.9V 至 6V 输入电源轨的低电压应用

3 说明

TPS53317A 器件是一款设计为主要用于 DDR 终端的集成场效应晶体管 (FET) 同步降压稳压器。它能够提供一个值为 $\frac{1}{2} V_{DDQ}$ 的经稳压输出，此输出具有吸收电流和源电流功能。TPS53317A 器件采用 D-CAP+ 运行模式，简单易用，所需外部组件数较少并可提供快速瞬态响应。该器件还可用于其他电流要求高达 6A 的负载点 (POL) 稳压应用。此外，该器件支持具有严格电压调节功能的 6A 完整灌电流输出。

该器件具有两种开关频率设定值 (600kHz 和 1MHz)，可提供集成压降支持、外部跟踪功能、预偏置启动、输出软放电、集成自举开关、电源正常功能、V5IN 引脚欠压锁定 (UVLO) 保护功能，支持采用陶瓷和 SP/POSCAP 电容。该器件支持的输入电压最高可达 6V，而输出电压在 0.45V 至 2.0V 范围内可调。

TPS53317A 器件采用 3.5mm × 4mm 20 引脚超薄四方扁平无引线 (VQFN) 封装 (绿色环保，符合 RoHS 标准并且无铅)，其中应用了 TI 专有的集成 MOSFET 和封装技术，其额定运行温度范围为 -40°C 至 85°C 。

器件信息⁽¹⁾

器件型号	封装	封装尺寸 (标称值)
TPS53317A	VQFN (20)	3.50mm × 4.00mm

(1) 要了解所有可用封装，请见数据表末尾的可订购产品附录。

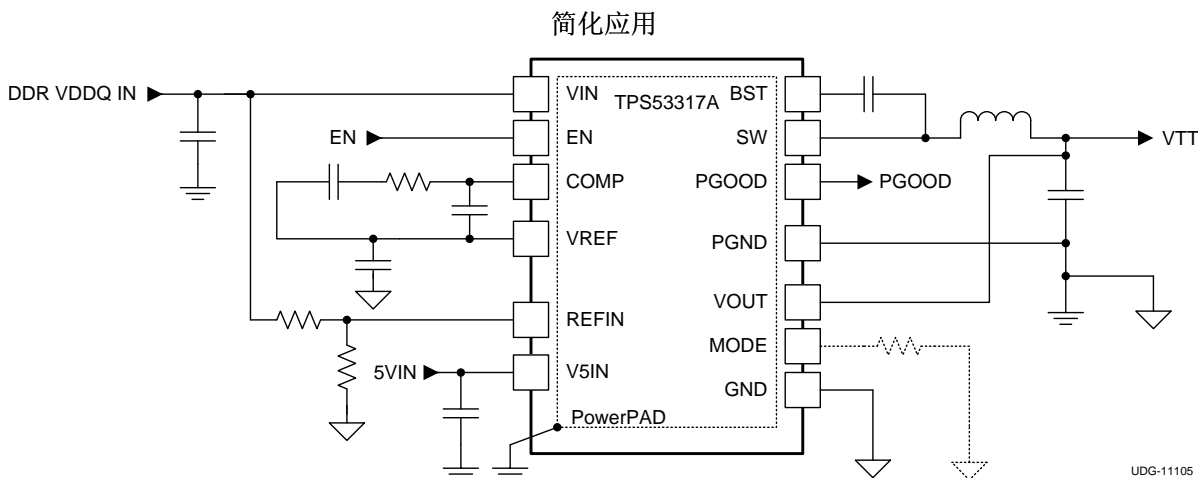

目录

1	特性	1	7.3	Feature Description	11
2	应用	1	7.4	Device Functional Modes	15
3	说明	1	8	Application and Implementation	19
4	修订历史记录	2	8.1	Application Information	19
5	Pin Configuration and Functions	3	8.2	Typical Applications	19
6	Specifications	4	9	Power Supply Recommendations	25
6.1	Absolute Maximum Ratings	4	10	Layout	25
6.2	ESD Ratings	4	10.1	Layout Guidelines	25
6.3	Recommended Operating Conditions	4	10.2	Layout Example	25
6.4	Thermal Information	5	11	器件和文档支持	26
6.5	Electrical Characteristics	5	11.1	社区资源	26
6.6	Typical Characteristics	7	11.2	商标	26
7	Detailed Description	10	11.3	静电放电警告	26
7.1	Overview	10	11.4	Glossary	26
7.2	Functional Block Diagram	10	12	机械、封装和可订购信息	26

4 修订历史记录

Changes from Original (November 2015) to Revision A

Page

•	文档状态已由产品预览更改为量产数据。	1
---	--------------------------	----------

5 Pin Configuration and Functions

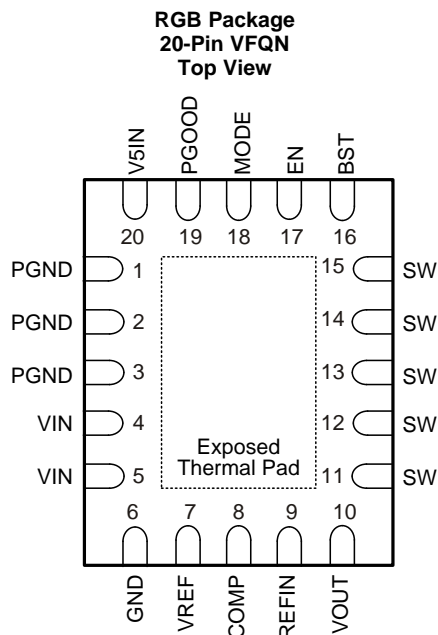

Pin Functions

PIN		I/O ⁽¹⁾	DESCRIPTION
NAME	NO.		
BST	16	I	Power supply for internal high-side gate driver. Connect a 0.1- μ F bootstrap capacitor between this pin and the SW pin. Include a series boot resistor when the voltage spike on switching node is above 7 V.
COMP	8	O	Connect an R-C-C network between this pin and VREF for loop compensation.
EN	17	I	Enable pin (3.3-V logic compatible).
GND	6	–	Analog ground.
MODE	18	I	Allows selection of different operation modes. (See 表 1)
PGND	1	G	Power ground.
	2		
	3		
PGOOD	19	O	Open drain power good output. Connect pullup resistor.
REFIN	9	I	External tracking reference input. Apply voltage between 0.45 V to 2.0 V. For non-tracking mode, connect REFIN to VREF via resistor divider.
SW	11	I/O	Switching node output.
	12		
	13		
	14		
	15		
V5IN	20	I	5-V power supply for analog circuits and gate drive.
VIN	4	I	Power supply input pin.
	5		
VOUT	10	I	Output voltage monitor input pin.
VREF	7	O	2.0-V reference output. Connect a ceramic capacitor with a value of 0.22- μ F or greater between this pin and GND.

(1) I = Input, O = Output, G = Ground

6 Specifications

6.1 Absolute Maximum Ratings

over operating free-air temperature range (unless otherwise noted) ⁽¹⁾

		MIN	MAX	UNIT
Input voltage range	BST (with respect to SW), V5IN, VIN	-0.3	7	V
	BST	-0.3	14	
	EN	-0.3	7	
	MODE, REFIN	-0.3	3.6	
	VOUT	-1	3.6	
Output voltage range	SW	-2	7	V
	SW (transient 20 ns and E = 5 µJ)	-3		
	COMP, VREF	-0.3	3.6	
	PGOOD	-0.3	7	
	PGND	-0.3	0.3	
Operating junction temperature, T _J		-40	150	°C
Lead temperature 1,6 mm (1/16 inch) from case for 10 seconds			300	°C
Storage temperature, T _{stg}		-55	150	°C

- (1) Stresses beyond those listed under *Absolute Maximum Ratings* may cause permanent damage to the device. These are stress ratings only, which do not imply functional operation of the device at these or any other conditions beyond those indicated under *Recommended Operating Conditions*. Exposure to absolute-maximum-rated conditions for extended periods may affect device reliability.

6.2 ESD Ratings

			VALUE	UNIT
V _(ESD)	Electrostatic discharge	Human-body model (HBM), per ANSI/ESDA/JEDEC JS-001 ⁽¹⁾	±2000	V
		Charged-device model (CDM), per JEDEC specification JESD22-C101 ⁽²⁾	±500	

- (1) JEDEC document JEP155 states that 500-V HBM allows safe manufacturing with a standard ESD control process. Manufacturing with less than 500-V HBM is possible with the necessary precautions. Pins listed as ±2000 V may actually have higher performance.
- (2) JEDEC document JEP157 states that 250-V CDM allows safe manufacturing with a standard ESD control process. Manufacturing with less than 250-V CDM is possible with the necessary precautions. Pins listed as ±500 V may actually have higher performance.

6.3 Recommended Operating Conditions

over operating free-air temperature range (unless otherwise noted)

		MIN	NOM	MAX	UNIT
Input voltage range	BST (with respect to SW), EN, VIN	-0.1		6.5	V
	V5IN	4.5		6.5	
	BST	-0.1		13.5	
	SW	-1.0		6.5	
	VOUT, MODE, REFIN	-0.1		3.5	
Output voltage range	COMP	-0.1		3.5	V
	VREF		2		
	PGOOD	-0.1		6.5	
	PGND	-0.1		0.1	
Operating temperature range, T _A		-40		85	°C

6.4 Thermal Information

THERMAL METRIC ⁽¹⁾		TPS53317A	UNIT
		RGB (VQFN)	
		20 PINS	
R _{θJA}	Junction-to-ambient thermal resistance	35.5	°C/W
R _{θJC(top)}	Junction-to-case (top) thermal resistance	39.6	°C/W
R _{θJB}	Junction-to-board thermal resistance	12.4	°C/W
ψ _{JT}	Junction-to-top characterization parameter	0.5	°C/W
ψ _{JB}	Junction-to-board characterization parameter	12.5	°C/W
R _{θJC(bot)}	Junction-to-case (bottom) thermal resistance	3.7	°C/W

(1) For more information about traditional and new thermal metrics, see the *Semiconductor and IC Package Thermal Metrics* application report, [SPRA953](#).

6.5 Electrical Characteristics

over recommended free-air temperature range, V_{V5IN} = 5.0 V, PGND = GND (unless otherwise noted)

PARAMETER	TEST CONDITIONS	MIN	TYP	MAX	UNIT	
SUPPLY: VOLTAGE, CURRENTS AND 5-V UVLO						
I _{VINSD}	VIN shutdown current	EN = 'LO'	0.02	5	μA	
V _{V5IN}	V5IN supply voltage	V5IN voltage range	4.5	5.0	6.5	V
I _{V5IN}	V5IN supply current	EN = 'HI', V5IN supply current, f _{SW} = 600 kHz	1.1	2	mA	
I _{V5INSD}	V5IN shutdown current	EN = 'LO', V5IN shutdown current	0.2	7.0	μA	
V _{V5UVLO}	V5IN UVLO	Ramp up; EN = 'HI'	4.20	4.37	4.50	V
V _{V5UVHYS}	V5IN UVLO hysteresis	Falling hysteresis	440		mV	
V _{VREFUVLO}	REF UVLO ⁽¹⁾	Rising edge of VREF, EN = 'HI'	1.8		V	
V _{VREFUVHYS}	REF UVLO hysteresis ⁽¹⁾		100		mV	
V _{POR5VFILT}	Reset	OVP latch is reset by V5IN falling below the reset threshold	1.5	2.3	3.1	V
VOLTAGE FEEDBACK LOOP: VREF, VOUT, AND VOLTAGE GM AMPLIFIER						
V _{OUTTOL}	Output voltage accuracy	V _{REFIN} = 1 V, No droop	-1%	0%	1%	
		V _{REFIN} = 0.6 V, No droop	-1%	0%	1%	
V _{VREF}	VREF	I _{VREF} = 0 μA	1.98	2.00	2.02	V
		I _{VREF} = 50 μA	1.975	2.000	2.025	
I _{REFSNK}	VREF sink current	V _{VREF} = 2.05 V	2.5		mA	
g _M	Transconductance		1.00		mS	
V _{CM}	Common mode input voltage range ⁽¹⁾		0	2	V	
V _{DM}	Differential mode input voltage		0	80	mV	
I _{COMPSNK}	COMP pin maximum sinking current	V _{COMP} = 2 V, (V _{REFIN} - V _{OUT}) = 80 mV	80		μA	
I _{COMPSRC}	COMP pin maximum sourcing current	V _{COMP} = 2 V	-80		μA	
V _{OFFSET}	Input offset voltage	T _A = 25°C	0		mV	
R _{DSCH}	Output voltage discharge resistance		42		Ω	
f _{-3dBVL}	-3dB Frequency ⁽¹⁾		4.5	6.0	7.5	MHz
CURRENT SENSE: CURRENT SENSE AMPLIFIER, OVERCURRENT AND ZERO CROSSING						
A _{CSINT}	Internal current sense gain	Gain from the current of the low-side FET to PWM comparator when PWM = "OFF"	43	53	57	mV/A
I _{OCL}	Positive overcurrent limit (valley)		7.6		A	
I _{OCL(neg)}	Negative overcurrent limit (valley)		-9.3		A	
V _{ZXOFF}	Zero crossing comp internal offset		0		mV	

(1) Ensured by design, not production tested.

Electrical Characteristics (continued)

 over recommended free-air temperature range, $V_{V5IN} = 5.0\text{ V}$, PGND = GND (unless otherwise noted)

PARAMETER		TEST CONDITIONS	MIN	TYP	MAX	UNIT
PROTECTION: OVP, UVP, PGOOD, and THERMAL SHUTDOWN						
V_{PGDLL}	PGOOD deassert to lower (PGOOD → Low)	Measured at the VOUT pin wrt/ V_{REFIN}		84%		
$V_{PGHYSHL}$	PGOOD high hysteresis			8%		
V_{PGDLH}	PGOOD de-assert to higher (PGOOD → Low)	Measured at the VOUT pin wrt/ V_{REFIN}		116%		
$V_{PGHYSHH}$	PGOOD high hysteresis			-8%		
$V_{INMINPG}$	Minimum VIN voltage for valid PGOOD	Measured at the VIN pin with a 2-mA sink current on PGOOD pin. V5IN is grounded here. ⁽²⁾	0.9	1.3	1.5	V
V_{OVP}	OVP threshold	Measured at the VOUT pin wrt/ V_{REFIN} , $V_{REFIN} = 1\text{ V}$	117%	120%	123%	
V_{UVP}	UVP threshold	Measured at the VOUT pin wrt/ V_{REFIN} , device latches OFF, begins soft-stop, $V_{REFIN} = 1\text{ V}$	65%	68%	71%	
TH_{SD}	Thermal shutdown ⁽¹⁾	Latch off controller, attempt soft-stop.		145		°C
$TH_{SD(hys)}$	Thermal Shutdown hysteresis ⁽¹⁾	Controller re-starts after temperature has dropped		10		°C
DRIVERS: BOOT STRAP SWITCH						
$R_{DSONBST}$	Internal BST switch on-resistance	$I_{BST} = 10\text{ mA}$, $T_A = 25^\circ\text{C}$			10	Ω
I_{BSTLK}	Internal BST switch leakage current	$V_{BST} = 14\text{ V}$, $V_{SW} = 7\text{ V}$			1	μA
TIMERS: ON-TIME, MINIMUM OFF-TIME, SS, AND I/O TIMINGS						
$t_{ONESHOTC}$	PWM one-shot ⁽¹⁾	$V_{VIN} = 5\text{ V}$, $V_{VOUT} = 1.05\text{ V}$, $f_{SW} = 1\text{ MHz}$		210		ns
		$V_{VIN} = 5\text{ V}$, $V_{VOUT} = 1.05\text{ V}$, $f_{SW} = 600\text{ kHz}$		310		
$t_{MIN(off)}$	Minimum OFF time	$V_{VIN} = 5\text{ V}$, $V_{VOUT} = 1.05\text{ V}$, $f_{SW} = 1\text{ MHz}$, DRVL on, SW = PGND, $V_{VOUT} < V_{REFIN}$		270		ns
$t_{INT(SS)}$	Soft-start time	From V_{OUT} ramp starting to $V_{OUT} = 95\%$, default setting		1.6		ms
$t_{INT(SSDLY)}$	Internal soft-start delay time	From $V_{VREF} = 2\text{ V}$ to V_{OUT} is ready to ramp up		260		μs
t_{PGDPLY}	PGOOD startup delay time	At external tracking, the time from VOUT is ready to ramp up		8		ms
$t_{PGDPDLYH}$	PGOOD high propagation delay time	50 mV over drive, rising edge	0.8	1	1.2	ms
$t_{PGDPDLYL}$	PGOOD low propagation delay time	50 mV over drive, falling edge		10		μs
t_{OVPDLY}	OVP delay time	Time from the VOUT pin out of +20% of V_{REFIN} to OVP fault		10		μs
$t_{UVDLYEN}$	Undervoltage fault enable delay	Time from EN_INT going high to undervoltage fault is ready		2		ms
		External tracking from VOUT ramp starts		8		
t_{UVPDLY}	UVP delay time	Time from the VOUT pin out of -32% of V_{REFIN} to UVP fault		256		μs
LOGIC PINS: I/O VOLTAGE AND CURRENT						
	PGOOD pull-down voltage	PGOOD low impedance, $I_{SINK} = 4\text{ mA}$, $V_{V5IN} = 4.5\text{ V}$			0.3	V
	PGOOD leakage current	PGOOD high impedance, forced to 5.5 V	-1	0	1	μA
	EN logic high	EN, VCCP logic	2			V
	EN logic low	EN, VCCP logic			0.5	V
	EN input current				1	μA

(2) If V_{V5IN} is higher than 1.5 V, PGOOD is valid regardless of the voltage applied at VIN. This is based on bench testing.

Electrical Characteristics (continued)

over recommended free-air temperature range, $V_{VIN} = 5.0\text{ V}$, PGND = GND (unless otherwise noted)

PARAMETER	TEST CONDITIONS	MIN	TYP	MAX	UNIT
MODE threshold voltage ⁽³⁾	Threshold 1	80	130	180	mV
	Threshold 2	200	250	300	
	Threshold 3	370	420	470	
	Threshold 4	550	600	650	
	Threshold 5	830	880	930	
	Threshold 6	1200	1250	1300	
	Threshold 7	1765	1800	1850	
MODE current			15		μA

(3) See 表 1 for descriptions of MODE parameters.

6.6 Typical Characteristics

Characterization data tested using the TPS53317AEVM-726 where the external tracking input sets the output voltage and operates in non-droop mode. See SLUUBD2 for detailed configuration.



图 1. Efficiency vs. Output Current



图 2. Efficiency vs. Output Current

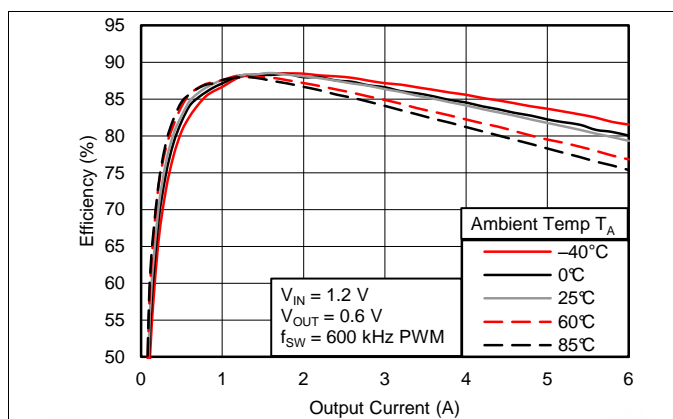

图 3. Efficiency vs. Output Current

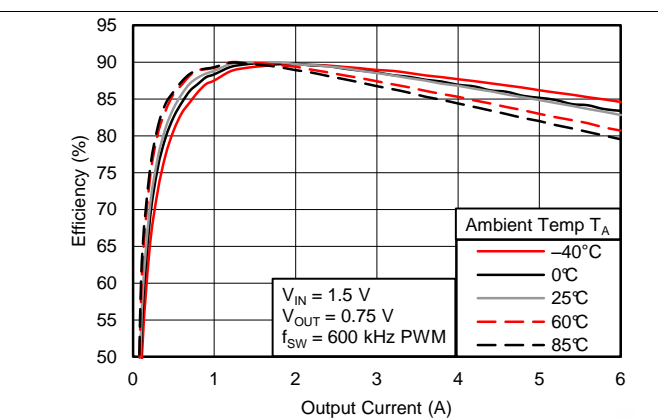

图 4. Efficiency vs. Output Current

Typical Characteristics (接下页)

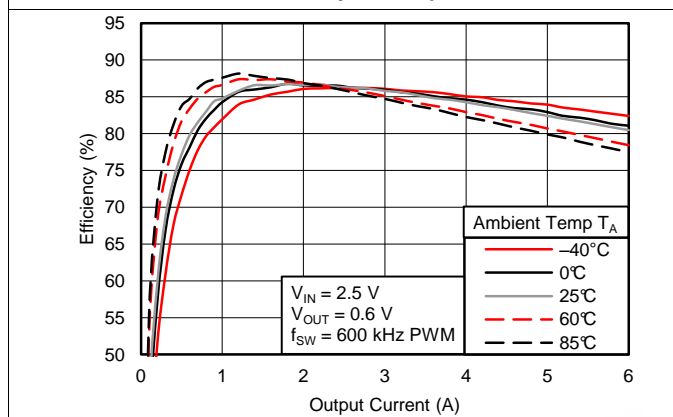
Characterization data tested using the TPS53317A EVM-726 where the external tracking input sets the output voltage and operates in non-droop mode. See [SLUUBD2](#) for detailed configuration.

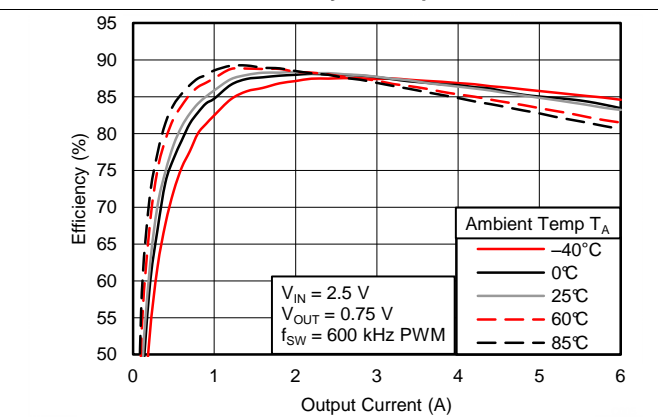

图 5. Efficiency vs. Output Current

图 6. Efficiency vs. Output Current

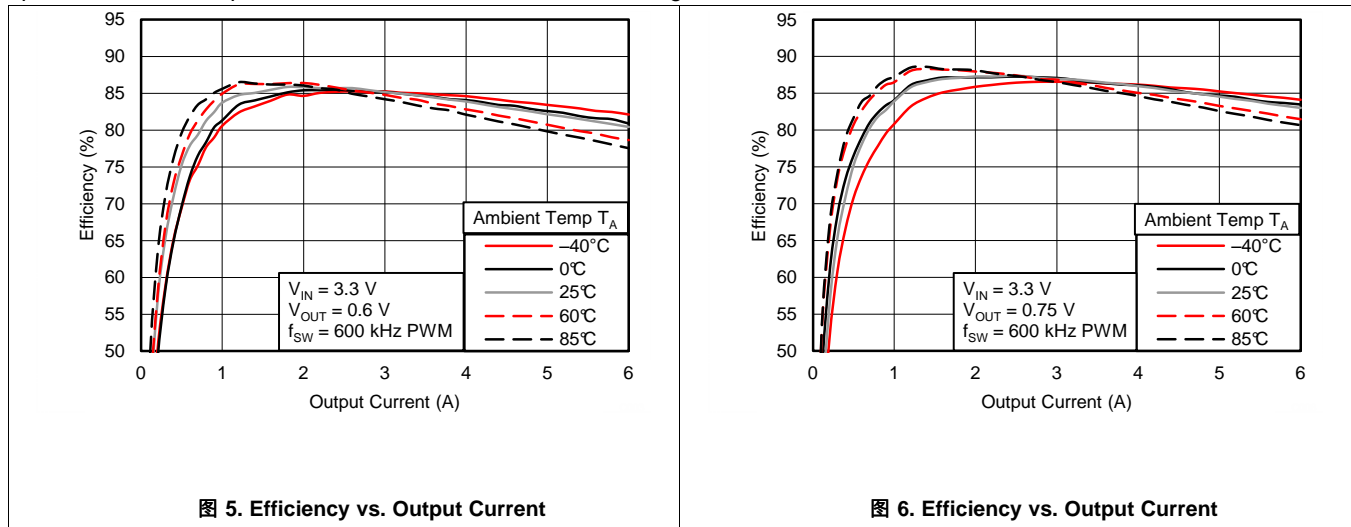

图 7. Load Regulation

图 8. Load Regulation

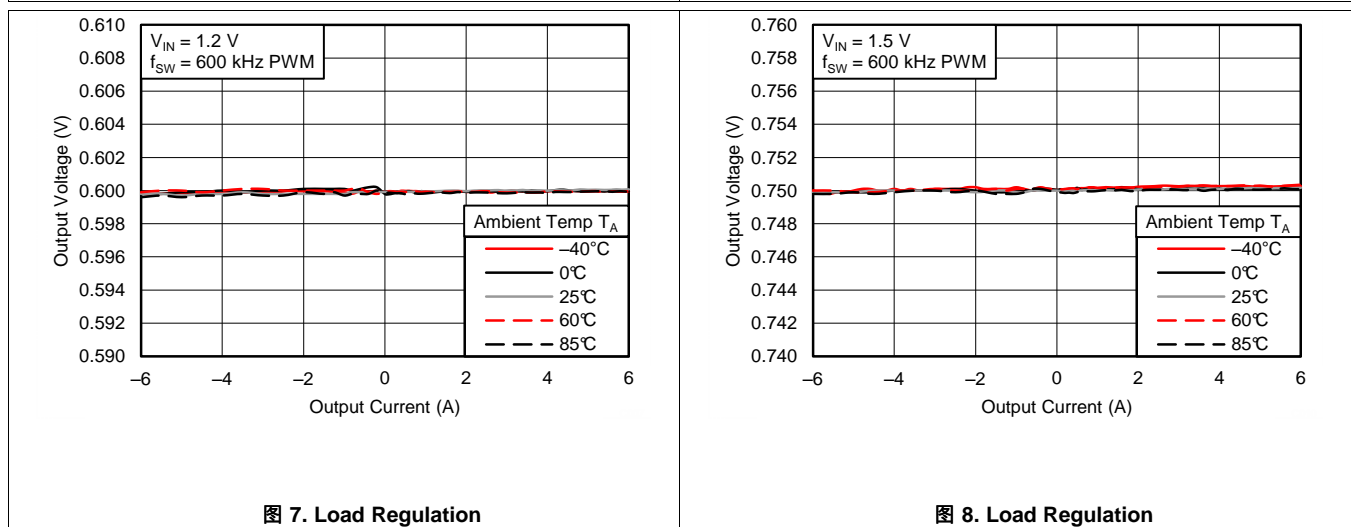

图 9. Load Regulation

图 10. Load Regulation

Typical Characteristics (接下页)

Characterization data tested using the TPS53317A-EVM-726 where the external tracking input sets the output voltage and operates in non-droop mode. See [SLUUBD2](#) for detailed configuration.

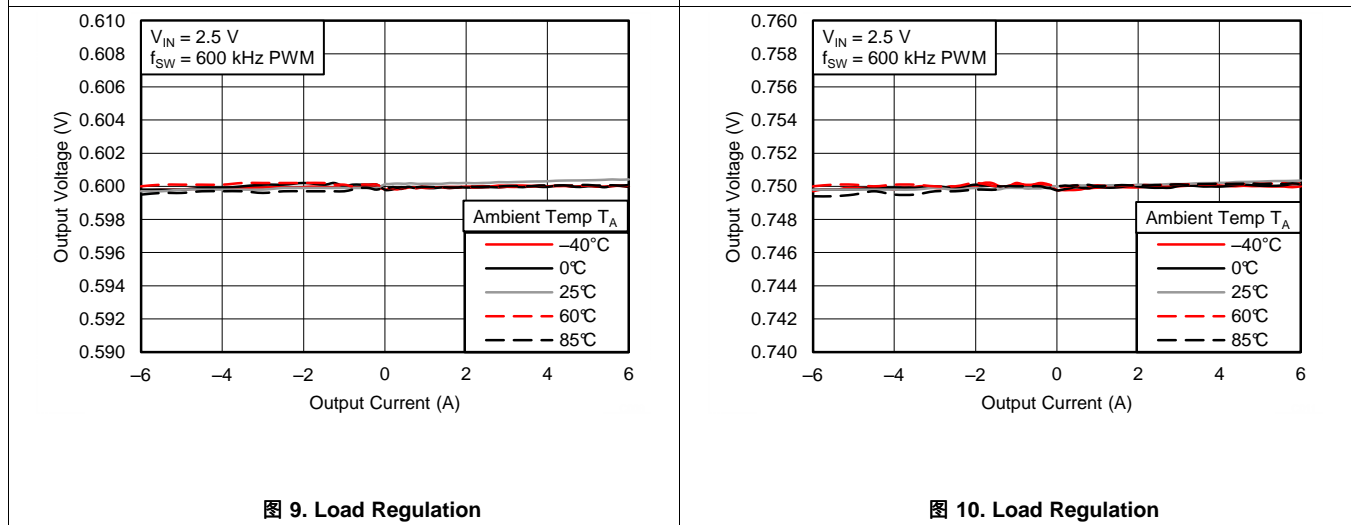
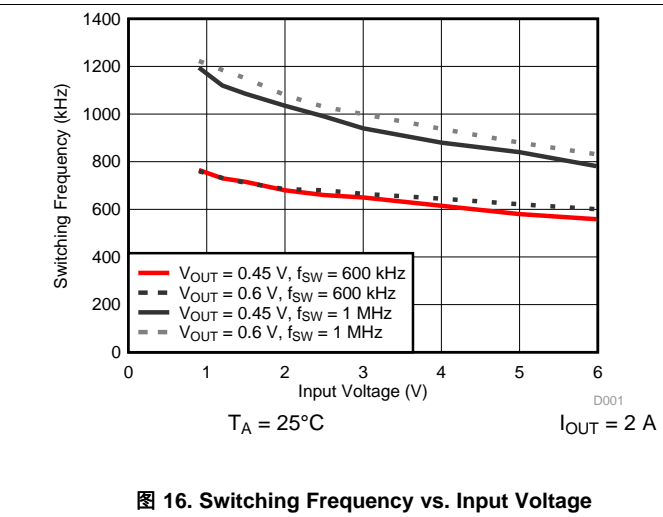
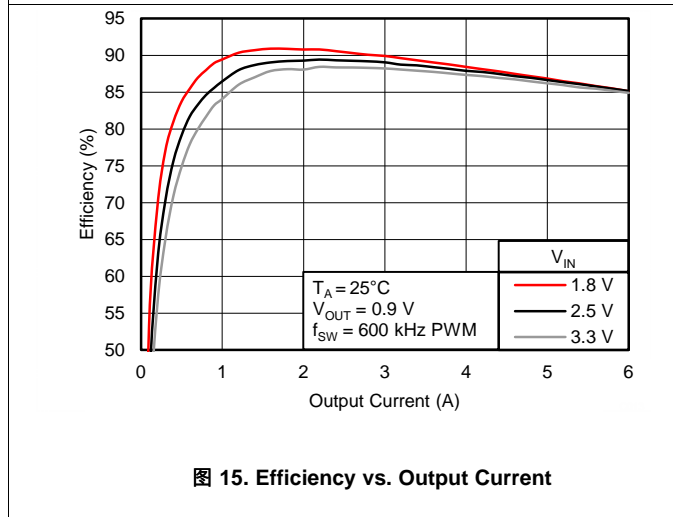
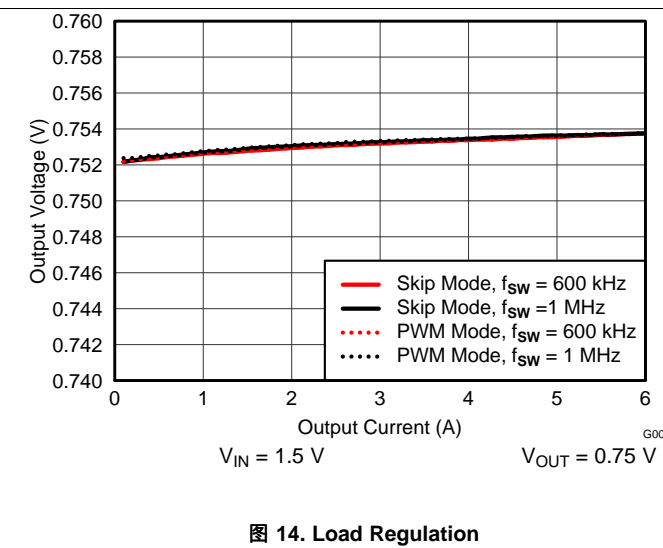
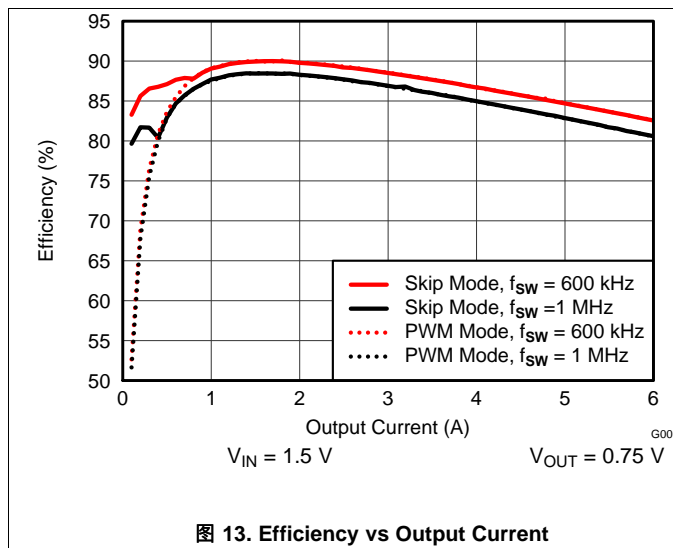
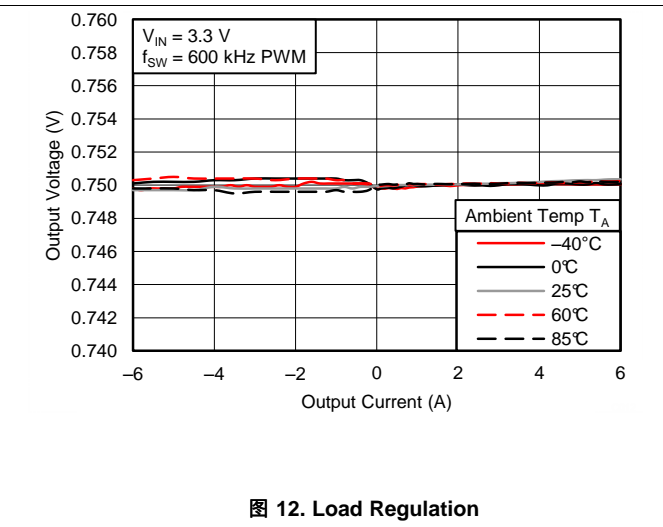
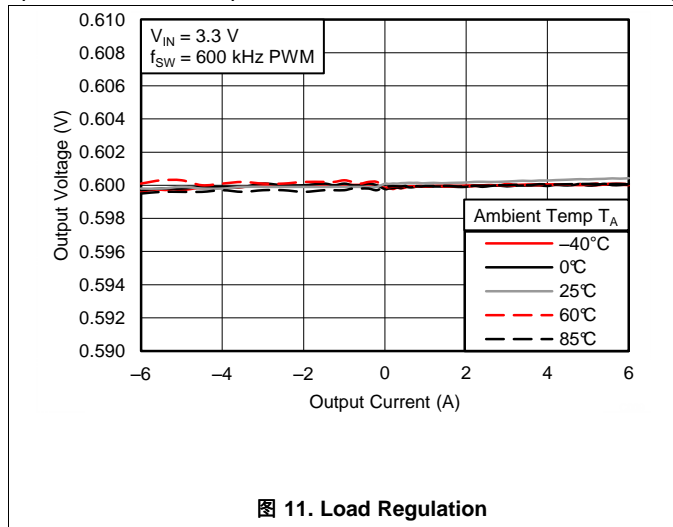

7 Detailed Description

7.1 Overview

The TPS53317A device is a D-CAP+™ mode adaptive on-time converter. Integrated high-side and low-side FETs support a maximum of 6-A DC output current. The converter automatically operates in discontinuous conduction mode (DCM) to optimize light-load efficiency. Multiple switching frequencies are provided to enable optimization of the power train for the cost, size and efficiency requirements of the design (see 表 1).

In adaptive on-time converters, the controller varies the on-time as a function of input and output voltage to maintain a nearly constant frequency during steady-state conditions. In conventional constant on-time converters, each cycle begins when the output voltage crosses to a fixed reference level. However, in the TPS53317A device, the cycle begins when the current feedback reaches an error voltage level which is the amplified difference between the reference voltage and the feedback voltage.

7.2 Functional Block Diagram

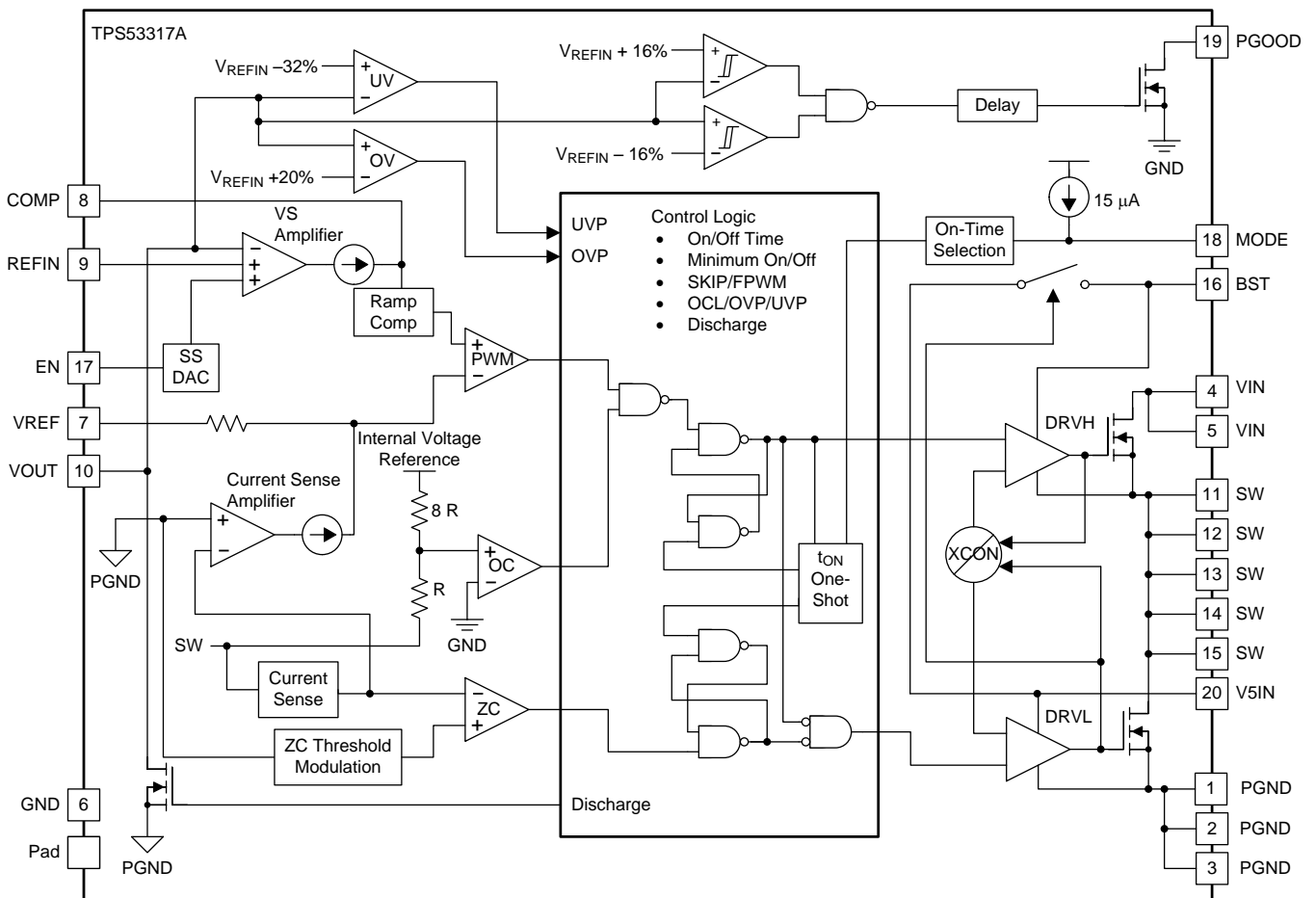

UDG-11106

7.3 Feature Description

7.3.1 PWM Operation

Referring to [图 17](#), in steady state, continuous conduction mode, the converter operates in the following way.

Starting with the condition that the top FET is off and the bottom FET is on, the current feedback (V_{CS}) is higher than the error amplifier output (V_{COMP}). V_{CS} falls until it hits V_{COMP} , which contains a component of the output ripple voltage. V_{CS} is not directly accessible by measuring signals on pins of TPS53317A device. The PWM comparator senses where the two waveforms cross and triggers the on-time generator.

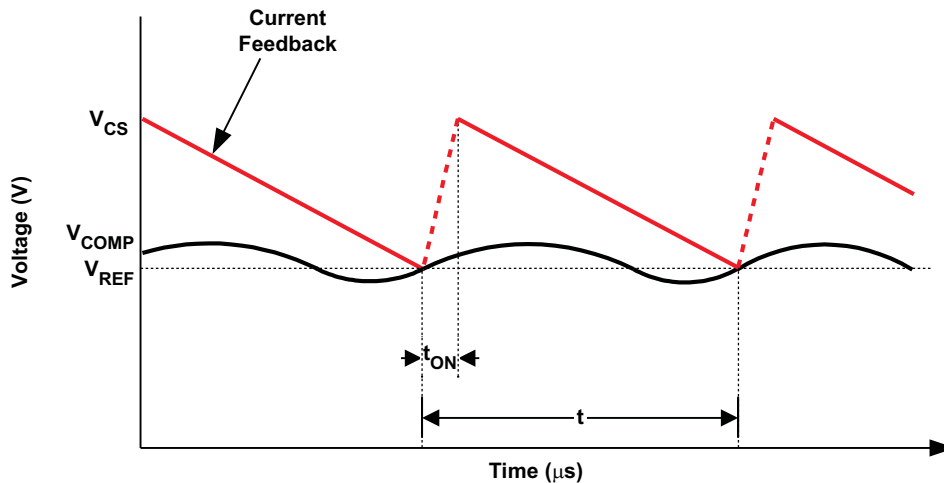

UDG-10187

图 17. D-CAP+™ Mode Basic Waveforms

The current feedback is an amplified and filtered version of the voltage between PGND and SW during low-side FET on-time. The device also provides a single-ended voltage (V_{OUT}) feedback to increase the system accuracy and reduce the dependence of circuit performance on layout.

7.3.2 PWM Frequency and Adaptive On-Time Control

In general, the on-time (at the SW node) can be estimated by [公式 1](#).

$$t_{ON} = \frac{V_{OUT}}{V_{IN}} \times \frac{1}{f_{SW}}$$

where

- f_{SW} is the frequency selected by the connection of the MODE pin (1)

The on-time pulse is sent to the top FET. The inductor current and the current feedback rises to peak value. Each ON pulse is latched to prevent double pulsing. Switching frequency settings are shown in [表 1](#).

7.3.3 Light-Load Power Saving Features

The TPS53317A device has an automatic pulse-skipping mode to provide excellent efficiency over a wide load range. The converter senses inductor current and prevents negative flow by shutting off the low-side gate driver. This saves power by eliminating re-circulation of the inductor current. Further, when the bottom FET shuts off, the converter enters discontinuous mode, and the switching frequency decreases, thus reducing switching losses as well.

The device also provides a special light-load power saving feature, called ripple reduction. Essentially, it reduces the on-time in SKIP mode to effectively reduce the output voltage ripple associated with using an all MLCC capacitor output power stage design.

Feature Description (接下页)

7.3.4 Power Sequences

7.3.4.1 Non-Tracking Startup

The TPS53317A device can be configured for non-tracking application. When non-tracking is configured, output voltage is regulated to the REFIN voltage which taps off the voltage dividers from the 2-V reference voltage. Either the EN pin or the V5IN pin can be used to start up the device. The device uses internal voltage servo DAC to provide a 1.6-ms soft-start time during soft-start initialization. (See [图 19](#).)

In a non-tracking application, the output voltage is determined by the resistive divider between the VREF pin and the REFIN pin.

$$V_{OUT} = V_{REF} \times \frac{R2}{R1 + R2} \quad (2)$$



图 18. Non-Tracking Configuration



图 19. Non-Tracking Startup Timing

Feature Description (接下页)

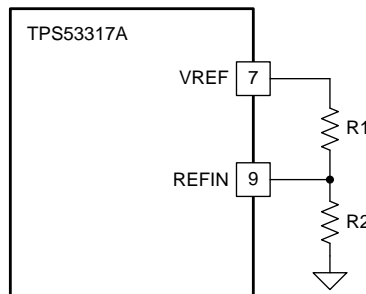
7.3.4.2 Tracking Startup

The TPS53317A device can also be configured for tracking application. When tracking configuration is desired, output voltage is also regulated to the REFIN voltage which comes from an external power source. In order for the device to differentiate between a non-tracking configuration or a tracking configuration, there is a minimum delay time of 260 μs required between the time when VREF reaches 2 V to the time when the REFIN pin voltage can be applied, in order for the device to track properly (see 图 22). The valid REFIN voltage range is between 0.45 V and 2 V.

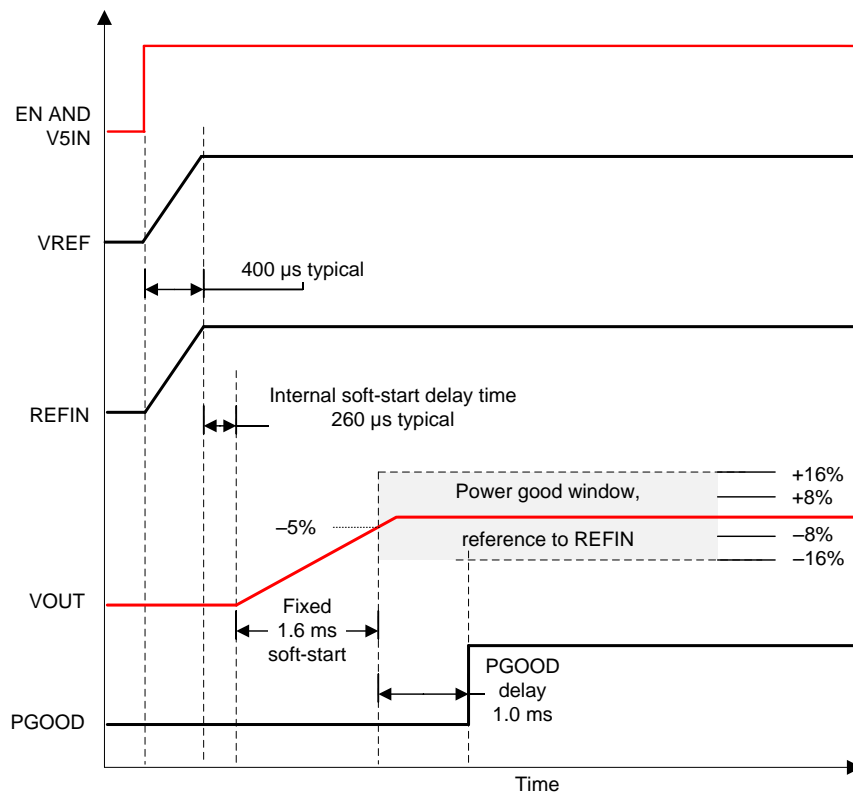
In a tracking application, the output voltage should be one half of the VDDQ voltage. VDDQ can be VIN or it can be an additional voltage rail. Thus, R1= R2 both in 图 20 and 图 21.

$$V_{OUT} = \frac{1}{2} \times V_{VDDQ} \tag{3}$$



图 20. Tracking Configuration 1



图 21. Tracking Configuration 2

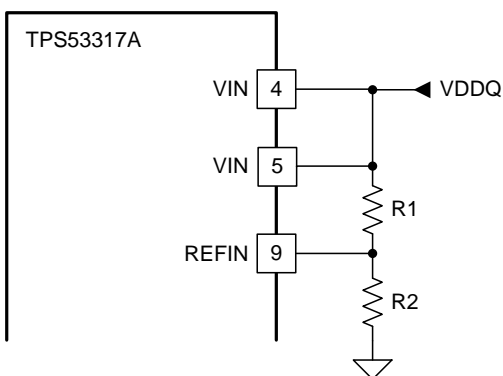

图 22. Tracking Startup Timing

Select PWM mode for an application that requires external tracking, because the output voltage can not be decreased during a no-load condition when the device operates in SKIP mode.

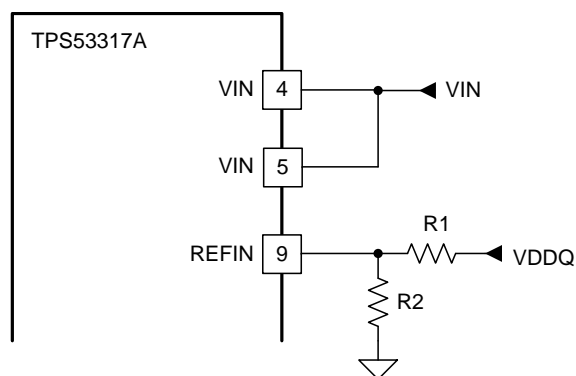
Feature Description (接下页)

7.3.5 Protection Features

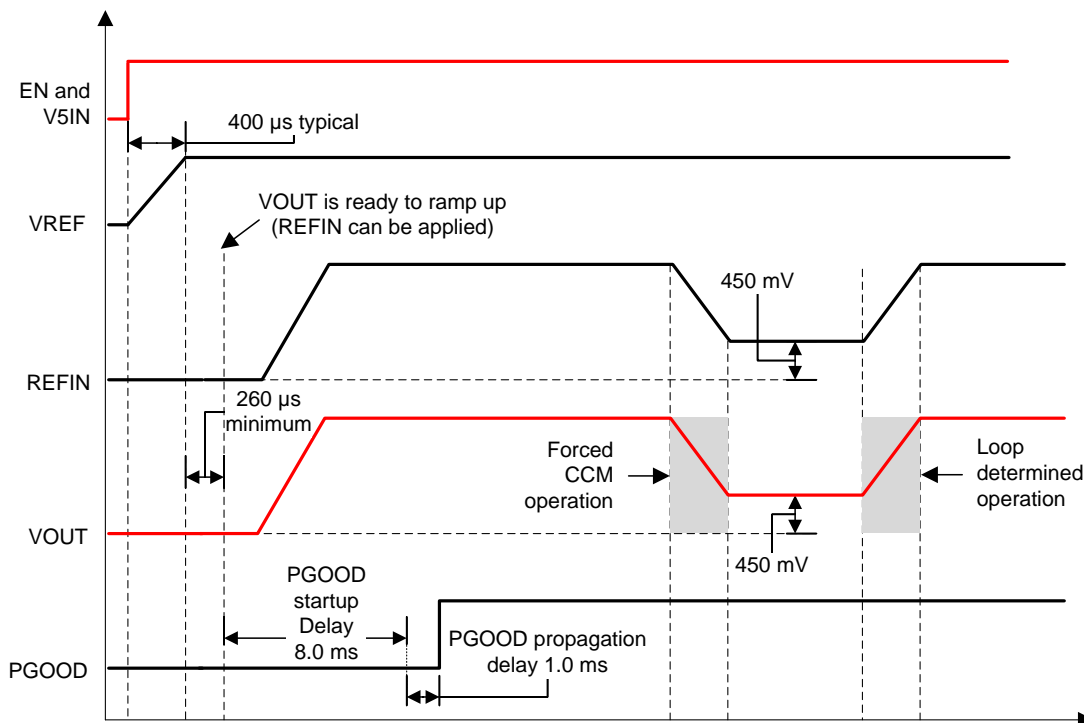
The TPS53317A device offers many features to protect the converter power train as well as the system electronics.

7.3.5.1 5-V Undervoltage Protection (UVLO)

The TPS53317A device continuously monitors the voltage on the V5IN pin to ensure that the voltage level is high enough to bias the device properly and to provide sufficient gate drive potential to maintain high efficiency. The converter starts with approximately 4.3 V and has a nominal 440 mV of hysteresis. If the 5-V UVLO limit is reached, the converter transitions the phase node into an off function, and the converter remains in the off state until the device is reset by cycling the 5-V supply until the 5-V POR is reached (2.3-V nominal). The power input does not have a UVLO function.

7.3.5.2 Power Good Signals

The TPS53317A device has one open-drain *power good* (PGOOD) pin. During startup, there is a 1-ms power good high propagation delay. The PGOOD pin de-asserts as soon as the EN pin is pulled low or an undervoltage condition on V5IN or any other fault is detected.

7.3.5.3 Output Overvoltage Protection (OVP)

In addition to the power good function described above, the TPS53317A device has additional OVP and UVP thresholds and protection circuits.

An OVP condition is detected when the output voltage is approximately $120\% \times V_{REFIN}$. In this case, the converter de-asserts the PGOOD signals and performs the overvoltage protection function. During OVP, the low-side FET is always on before triggering a negative overcurrent. When a negative OC is also tripped, the low-side FET is no longer continuously on, and pulsed signals are generated to limit the negative inductor current. When the VOUT pin voltage drops below 250 mV, the low-side FET turns off and the converter latches off. The converter remains in the off state until the device is reset by cycling the 5-V supply until the 5-V POR is reached (2.3-V nominal) or when the EN pin is toggled off and on.

7.3.5.4 Output Undervoltage Protection (UVP)

Output undervoltage protection works in conjunction with the current protection described in the [Overcurrent Protection](#) and [Overcurrent Limit](#) sections. If the output voltage drops below 68% of V_{REFIN} , after approximately a 250- μ s delay, the device stops switching and enters hiccup mode. After a hiccup waiting time, a restart is attempted. If the fault condition is not cleared, hiccup mode operation may continue indefinitely.

7.3.5.5 Overcurrent Protection

Both positive and negative overcurrent protection are provided in the TPS53317A device.

- Overcurrent Limit (OCL)
- Negative OCL

7.3.5.5.1 Overcurrent Limit

If the sensed current value is above the OCL setting, the converter delays the next ON pulse until the current drops below the OCL limit. Current limiting occurs on a pulse-by-pulse basis. The device uses a valley current limiting scheme where the DC OCL trip point is the OCL limit plus half of the inductor ripple current. The typical valley OCL threshold is 7.6 A or 5.4 A (depending on mode selection). The average output current limit calculation is shown in [公式 4](#).

During the overcurrent protection event, the output voltage droops if the duty cycle cannot satisfy output voltage requirements and continues to droop until the UVP limit is reached. Then, the converter de-asserts the PGOOD pin, and then enters hiccup mode after a 250- μ s delay. The converter remains in hiccup mode until the fault is cleared.

$$I_{OCL(dc)} = I_{OCL(valley)} + \frac{1}{2} \times I_{P-P} \quad (4)$$

Feature Description (接下页)

7.3.5.5.2 Negative OCL

The negative OCL circuit acts when the converter is sinking current from the output capacitor(s). The converter continues to act in a *valley* mode, the typical value of the negative OCL set point is -9.3 A or -6.5 A (depending on mode selection).

7.3.6 Thermal Protection

The TPS53317A device has an internal temperature sensor. When the temperature reaches a nominal 145°C , the device shuts down until the temperature decreases by approximately 10°C , when the converter restarts.

7.4 Device Functional Modes

7.4.1 Non-Droop Configuration

The TPS53317A device can be configured as a non-droop solution. The benefit of a non-droop approach is that load regulation is flat, therefore, in a system where tight DC tolerance is desired, the non-droop approach is recommended. For the Intel system agent application, non-droop is recommended as the standard configuration.

The non-droop approach can be implemented by connecting a resistor and a capacitor between the COMP and the VREF pins. The purpose of the type II compensation is to obtain high DC feedback gain while minimizing the phase delay at unity gain cross over frequency of the converter.

The value of the resistor (R_C) can be calculated using the desired unity gain bandwidth of the converter, and the value of the capacitor (C_C) can be calculated by knowing where the zero location is desired. The capacitor C_P is optional, but recommended. Its appropriate capacitance value can be calculated using the desired pole location.

图 23 shows the basic implementation of the non-droop mode using the device



图 23. Non-Droop Mode Basic Implementation

Device Functional Modes (接下页)

图 24 shows shows the load regulation using non-droop configuration.

图 25 shows the transient response of the device using non-droop configuration, where $C_{OUT} = 3 \times 47 \mu\text{F}$. The applied step load is from 0 A to 2 A.

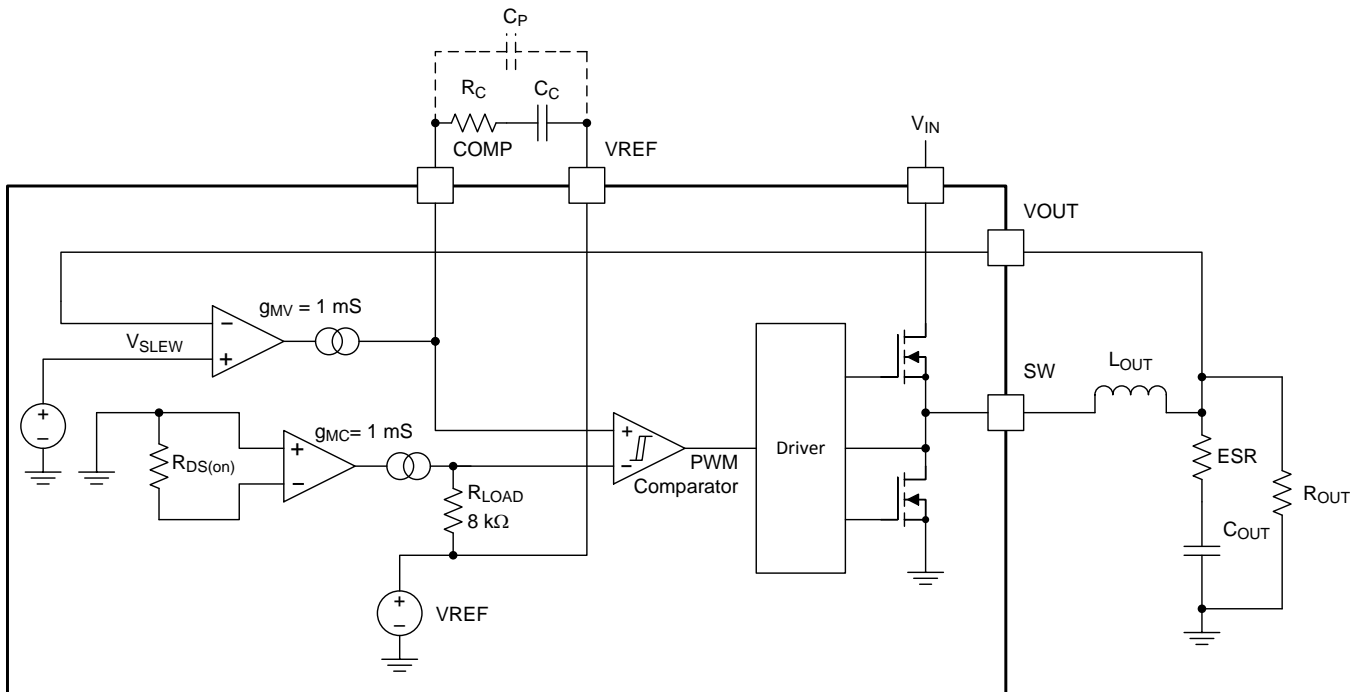
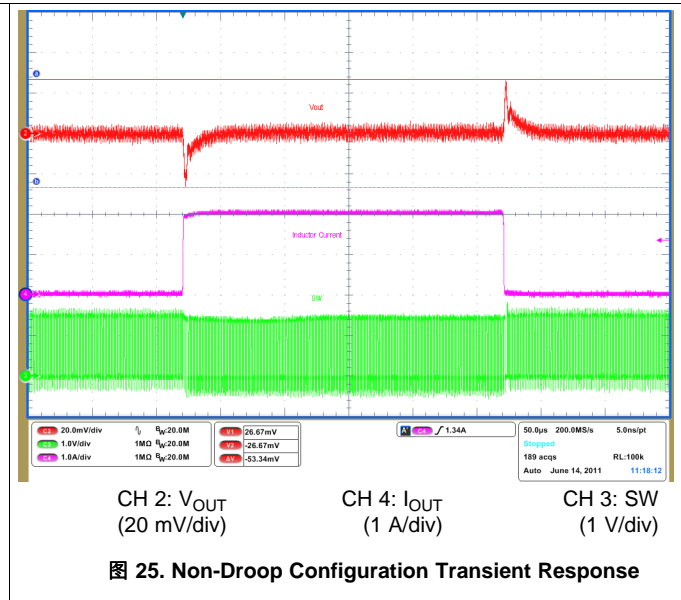
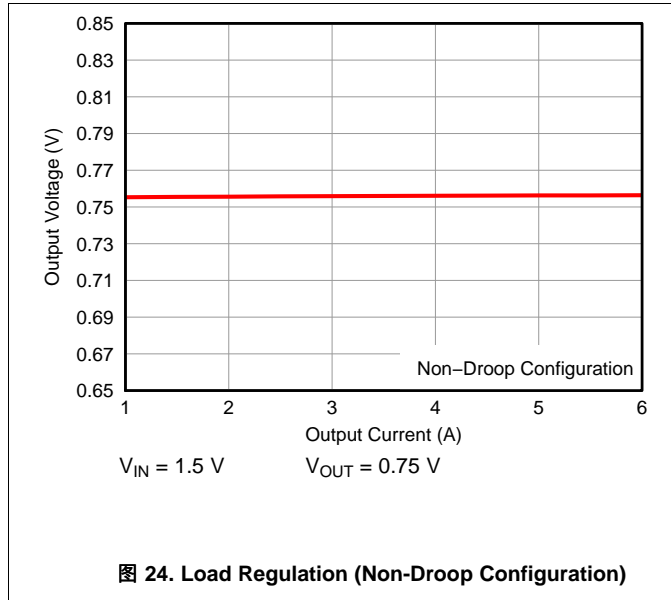

7.4.2 Droop Configuration

The terminology for droop is the same as *load line* or *voltage positioning* as defined in the Intel CPU V_{CORE} specification. Based on the actual tolerance requirement of the application, load-line set points can be defined to maximize either cost savings (by reducing output capacitors) or power reduction benefits.

Accurate droop voltage response is provided by the finite gain of the droop amplifier. The equation for droop voltage is shown in 公式 5.

$$V_{DROOP} = \frac{A_{CSINT} \times I_{OUT}}{R_{DROOP} \times g_M}$$

where

- low-side on-resistance is used as the current sensing element
 - A_{CSINT} is a constant, which nominally is 53 mV/A.
 - I_{OUT} is the DC current of the inductor, or the load current
 - R_{DROOP} is the value of resistor from the COMP pin to the VREF pin
 - g_M is the transconductance of the droop amplifier with nominal value of 1 mS
- (5)

公式 6 can be used to easily derive R_{DROOP} for any load line slope/droop design target.

$$R_{LOAD_LINE} = \frac{V_{DROOP}}{I_{OUT}} = \frac{A_{CSINT}}{R_{DROOP} \times g_M} \therefore R_{DROOP} = \frac{A_{CSINT}}{R_{LOAD_LINE} \times g_M}$$

(6)

Choose a value for the R_{DROOP} resistor that is below 20 kΩ. More than 20 kΩ of droop resistance may cause the loop to become unstable.

Device Functional Modes (接下页)

图 26 shows the basic implementation of the droop mode using the TPS53317A device.



图 26. DROOP Mode Basic Implementation

The droop (voltage positioning) method was originally recommended to reduce the number of external output capacitors required. The effective transient voltage range is increased because of the active voltage positioning (see 图 27).

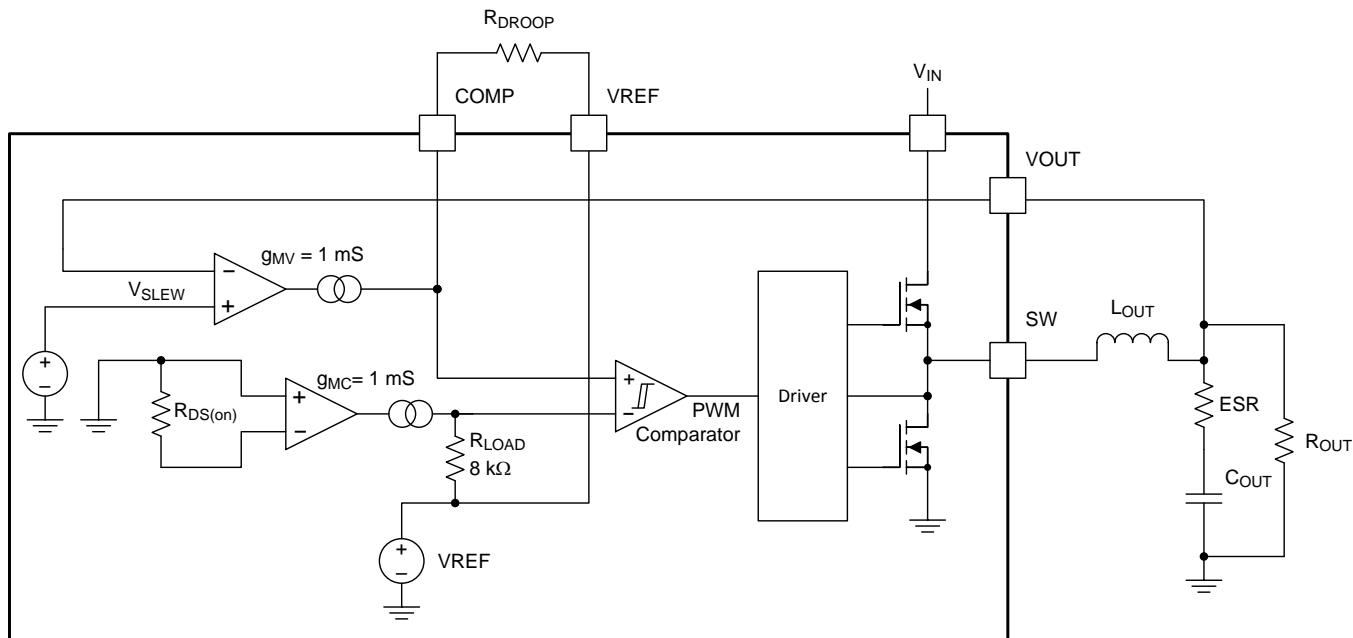

图 27. DROOP vs Non-DROOP in Transient Voltage Window

Device Functional Modes (接下页)

In applications where the DC and the AC tolerances are not separated, (meaning that there is no strict DC tolerance requirement) the droop method can be used.

表 1. Mode Definitions

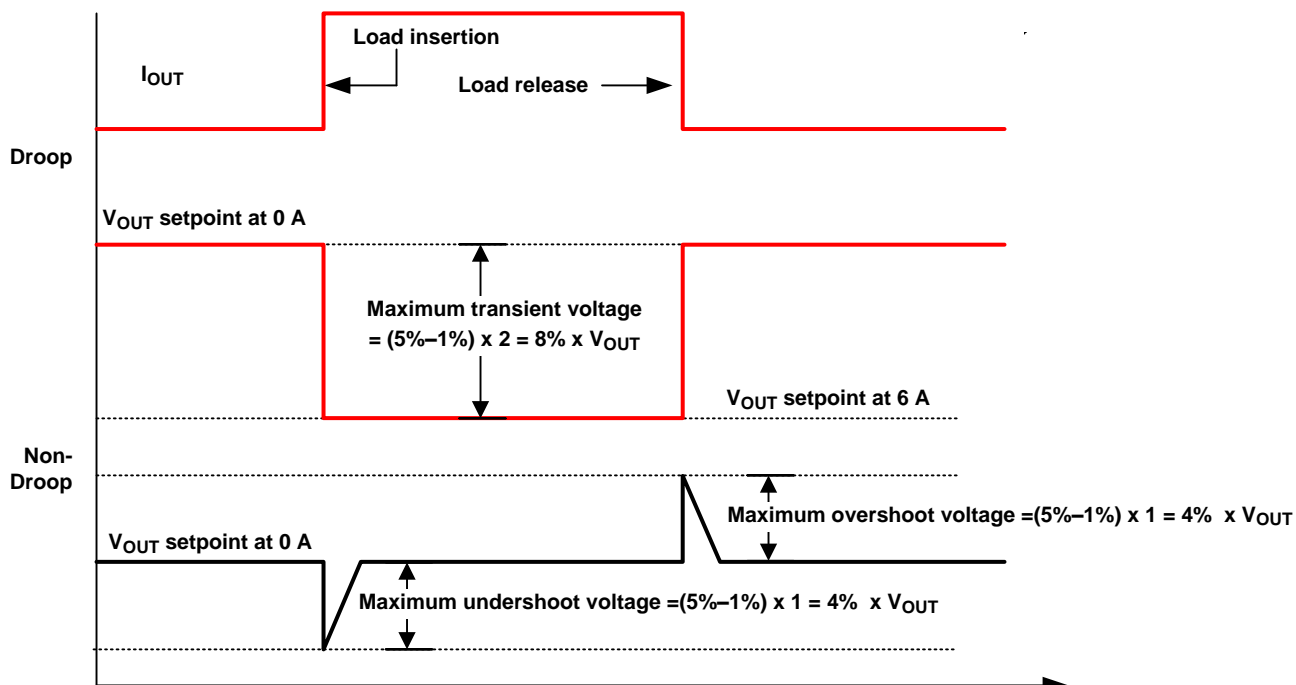
MODE	MODE RESISTANCE (kΩ)	LIGHT-LOAD POWER SAVING MODE	SWITCHING FREQUENCY (f _{sw})	OVERCURRENT LIMIT (OCL) VALLEY (A)
1	0	SKIP	600 kHz	7.6
2	12		600 kHz	5.4
3	22		1 MHz	5.4
4	33		1 MHz	7.6
5	47	PWM	600 kHz	7.6
6	68		600 kHz	5.4
7	100		1 MHz	5.4
8	OPEN		1 MHz	7.6

图 28 shows the load regulation of the 1.5-V rail using an R_{DRPOOP} value of 6.8 kΩ.

图 29 shows the transient response of the TPS53317A device using droop configuration and C_{OUT} = 3 × 47 μF. The applied step load is from 0 A to 2 A.

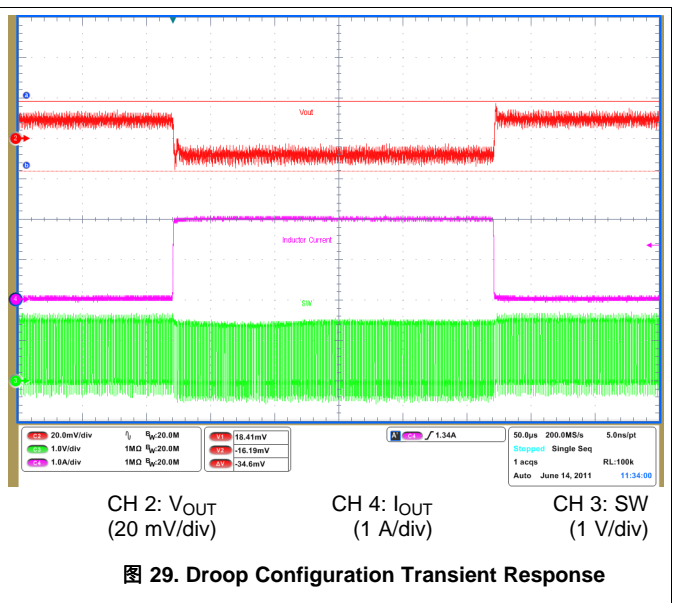
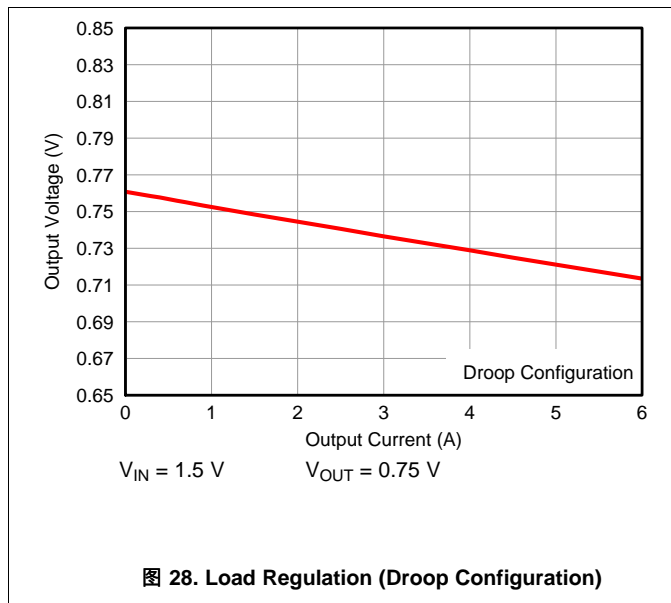

8 Application and Implementation

注

Information in the following applications sections is not part of the TI component specification, and TI does not warrant its accuracy or completeness. TI's customers are responsible for determining suitability of components for their purposes. Customers should validate and test their design implementation to confirm system functionality.

8.1 Application Information

The TPS53317A device is a FET-integrated synchronous buck regulator designed mainly for DDR termination. It can provide a regulated output at $\frac{1}{2}$ VDDQ with both sink and source capability. The device employs D-CAP+ mode operation that provides ease-of-use, low external component count and fast transient response.

8.2 Typical Applications

8.2.1 DDR4 SDRAM Application

This DDR4 application requires a tight load tolerance, fast transient response, and sinking current capability, the design uses a non-droop PWM configuration.



图 30. DDR4 SDRAM Application

8.2.1.1 Design Requirements

- Input voltage : $V_{IN} = 1.2$ V
- Output voltage: $V_{OUT} = 0.6$ V
- Maximum load step size of 3 A @ slew rate 7 A/ μ s (–1.5 A to 1.5 A)
- DC +AC + Ripple voltage regulation limit at sense point: ± 42 mV (0.642 V overshoot, 0.558 V undershoot)
- Maximum load: $I_{MAX} = 2.5$ A

Typical Applications (接下页)

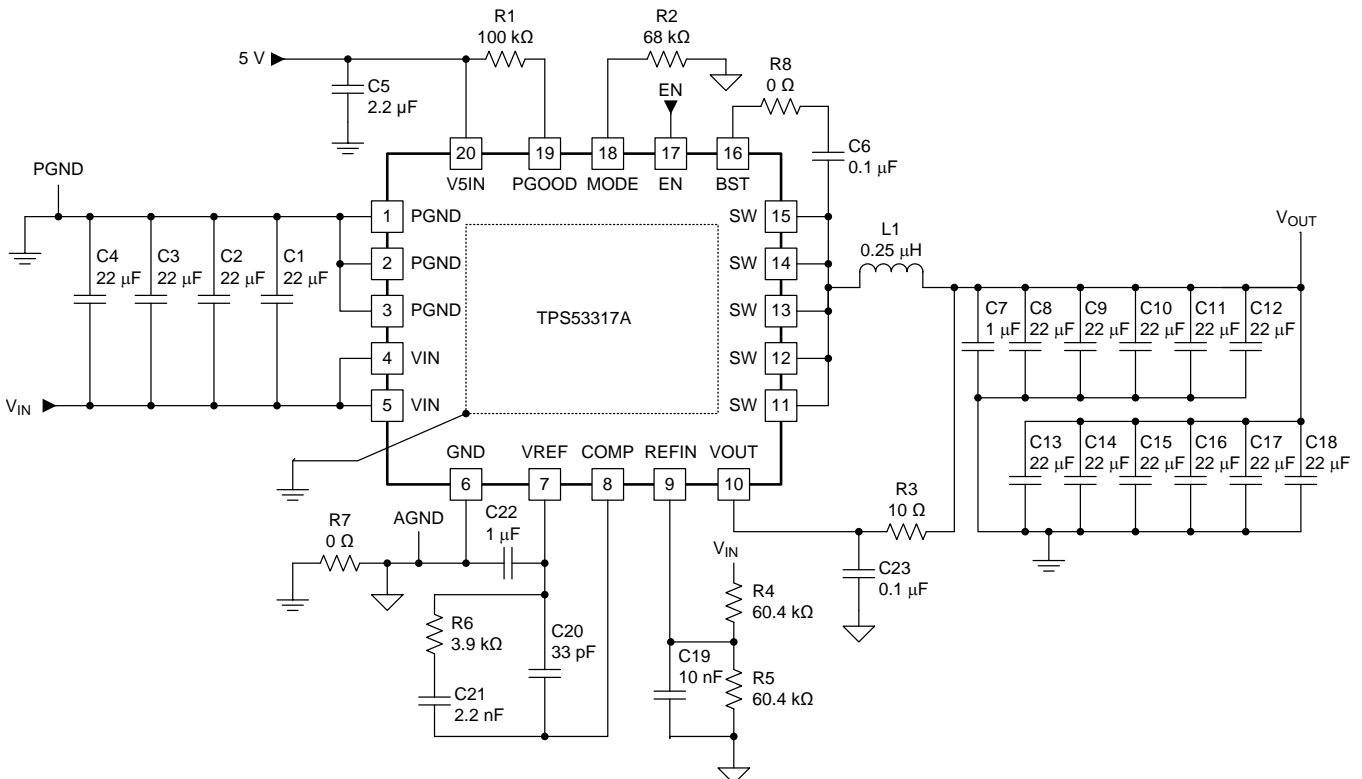
8.2.1.2 Detailed Design Procedure

8.2.1.2.1 Step 1. Determine Configuration

Because this DDR4 application requires a tight load tolerance, fast transient response, and sinking current capability, the design uses a non-droop PWM configuration. Choose 600-kHz switching frequency due to the duty cycle and minimum off-time of the device, and set an overcurrent (OC) valley limit of 5.4 A due to the maximum load requirement of 2.5 A. Referring to 表 1 select an R_{MODE} value of 68 k Ω .

8.2.1.2.2 Step 2. Select Inductor

Smaller inductor values have better transient performance but higher ripple and lower efficiency. High values have the opposite characteristics. It is common practice to limit the ripple current to 30% to 50% of the maximum current. Choose 50% to allow use of a smaller inductor for faster transient performance.

$$\Delta I_{P-P} = 2.5 \text{ A} \times 0.5 = 1.25 \text{ A} \quad (7)$$

$$L = \frac{1}{f_{SW} \times \Delta I_{P-P}} \times V_{OUT} \times (1 - D)$$

where

- D = duty cycle (8)

Because this device operates in DCAP+ mode, the frequency and duty cycle vary based on the input voltage, the output voltage and load. With a 2.5-A load, a 1.2-V input voltage and 0.60 V output voltage, f_{SW} is experimentally measured at approximately 800 kHz and duty cycle of 0.55. Therefore L is calculated as shown in 公式 10.

$$L = \frac{1}{(800 \text{ kHz} \times 1.25 \text{ A})} \times 0.6 \text{ V} \times 0.45 = 0.270 \mu\text{H} \quad (9)$$

Choose the closest standard value, 0.25 μH .

8.2.1.2.3 Step 3. Determine Output Capacitance

Use 公式 10 to calculate the output capacitance for a desired maximum overshoot.

$$C_{OUT(min),OS} = \frac{\Delta I_{OUT}^2 \times L}{2 \times V_{OUT} \times V_{OS}}$$

where

- $C_{OUT(min),OS}$ is the minimum output capacitance for a desired overshoot
- ΔI_{OUT} is the maximum output current change in the application
- V_{OUT} = desired output voltage
- V_{OS} is the desired output voltage change due to overshoot (10)

Choose a value of 30 mV to account for normal output voltage ripple.

$$C_{OUT(min),OS} = \frac{(3 \text{ A})^2 \times 0.25 \mu\text{H}}{2 \times 0.6 \text{ V} \times 0.03 \text{ V}} = 62.5 \mu\text{F} \quad (11)$$

Use 公式 12 to calculate the necessary output capacitance for a desired maximum undershoot.

$$C_{OUT(min),US} = \frac{\Delta I_{OUT}^2 \times L \times \left(\frac{V_{OUT}}{V_{IN}} \times t_{SW} + t_{MIN(off)} \right)}{2 \times V_{OUT} \times V_{US} \times \left(\frac{V_{IN} - V_{OUT}}{V_{IN}} \times t_{SW} - t_{MIN(off)} \right)}$$

where

- $C_{OUT(min),US}$ is the minimum output capacitance for a desired undershoot
- V_{US} is the desired output voltage change due to overshoot
- t_{SW} is the period of switch node
- $t_{MIN(off)}$ is the minimum off-time (270 ns) (12)

Typical Applications (接下页)

Again, choose 30 mV to account for normal output voltage ripple.

$$C_{OUT(min),US} = \frac{(3\text{ A})^2 \times 0.25\ \mu\text{H} \times \left(\frac{0.6\text{ V}}{1.2\text{ V}} \times \frac{1}{800\text{ kHz}} + 270\text{ ns}\right)}{2 \times 0.6\text{ V} \times 0.03\text{ V} \times \left(\frac{1.2\text{ V} - 0.6\text{ V}}{1.2\text{ V}} \times \frac{1}{800\text{ kHz}} - 270\text{ ns}\right)} = 157.6\ \mu\text{F} \quad (13)$$

The undershoot requirements determine, so there must be a minimum of 157.6 μF . Because this is a DDR application where size is also a consideration, this design uses only ceramic capacitors. To account for voltage de-rating of capacitors and provide additional margin, this design includes eleven 22- μF output capacitors.

8.2.1.2.4 Step 4. Input Capacitance

This design requires sufficient input capacitance to filter the input current from the host source. Use [公式 14](#) to calculate the necessary input capacitance.

$$C_{IN(min)} = I_{out} \times \frac{D \times (1 - D)}{\Delta V_{IN(P-P)} \times f_{SW}}$$

where

- $\Delta V_{IN(P-P)}$ is the desired input voltage ripple (typically 1% of the input voltage) (14)

$$C_{IN(min)} = 2.5\text{ A} \times \frac{0.55 \times (1 - 0.55)}{12\text{ mV} \times 800\text{ kHz}} = 64.45\ \mu\text{F} \quad (15)$$

As with the output capacitance selection, this design accounts for voltage de-rating of capacitors and provides additional margin, using four 22- μF input capacitors.

8.2.1.2.5 Step 5. Compensation Network

In order to achieve stable operation, the crossover frequency should be less than 1/5 of the switching frequency.

$$f_{CO} = \frac{1}{2\pi} \times \frac{g_M}{C_{OUT}} \times \frac{R_C}{R_S} = 80\text{ kHz}$$

where

- $R_S = 53\text{ m}\Omega$ (16)

Account for capacitor de-rating here and set the value of C_{OUT} to 160 μF , so that [公式 17](#) is true.

$$R_C = \frac{f_{CO} \times R_S \times 2\pi \times C_{OUT}}{g_M} = \frac{80\text{ kHz} \times 53\text{ m}\Omega \times 2\pi \times 160\ \mu\text{F}}{1\text{ mS}} = 4.26\text{ k}\Omega \quad (17)$$

Choose an R_C value of 3.9 $\text{k}\Omega$. Determine C_C by choosing the value of the zero created by R_C and C_C . Using the relationship described in [公式 18](#).

$$f_z = \frac{f_{CO}}{5} = \frac{1}{2\pi \times R_C \times C_C} \quad (18)$$

[公式 18](#) yields a C_C value of 2.55 nF. Choose the closest common capacitor value of 2.2 nF. To determine a value for C_P , first consider the relationship described in [公式 19](#).

$$f_p = \frac{1}{2\pi \times R_C \times \frac{C_C \times C_P}{C_C + C_P}} \approx \frac{1}{2\pi \times R_C \times C_P} \quad (19)$$

- $C_C \gg C_P$

Because $C_C \gg C_P$, set the pole to be two times the switching frequency as described in [公式 20](#).

$$C_P \cong \frac{1}{2\pi \times R_C \times 2f_{SW}} = \frac{1}{2\pi \times 3.9\text{ k}\Omega \times 2 \times 800\text{ kHz}} = 25.5\text{ pF} \quad (20)$$

To boost the gain margin, set C_P to 33 pF.

Typical Applications (接下页)



图 31. Compensation Network Circuit

8.2.1.2.6 Peripheral Component Selection

As described in 表 1, connect a 0.22- μF capacitor from the VREF pin to GND and connect a 0.1- μF bootstrap capacitor from the SW pin to the BST pin. Because the PGOOD pin is open drain, connect a pullup resistor between it and the 5-V rail.

8.2.1.3 Application Curves

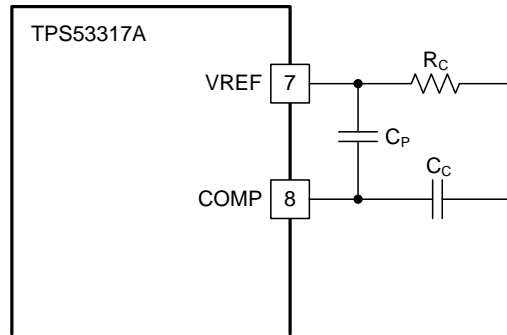

图 32. Efficiency



图 33. Load Transient

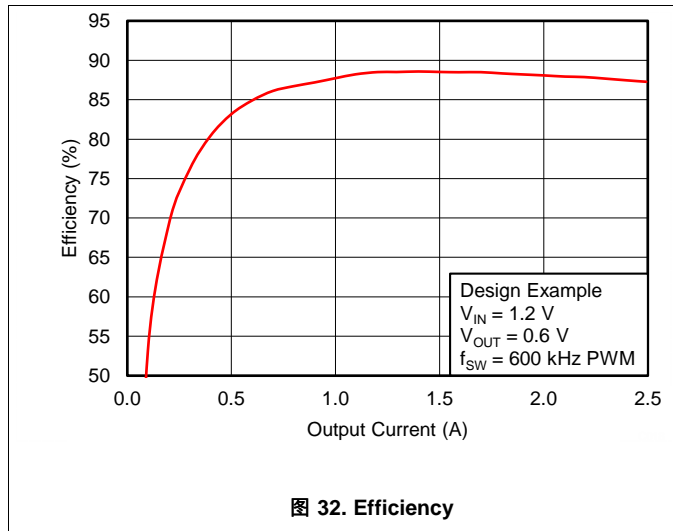

图 34. Bode Plot, No Load

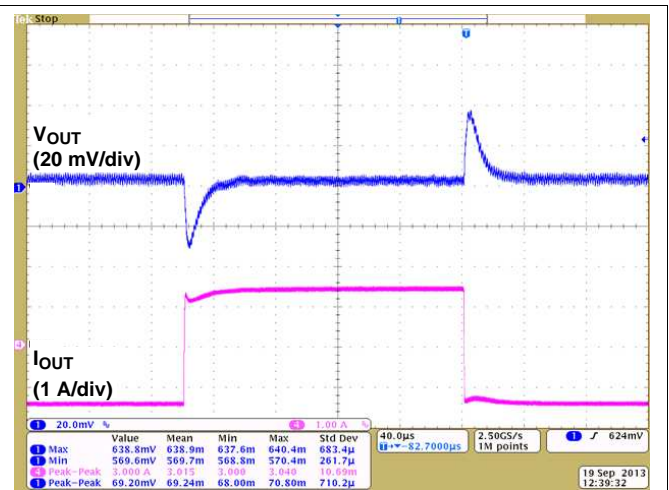

图 35. Bode Plot, Full Load

Typical Applications (接下一页)

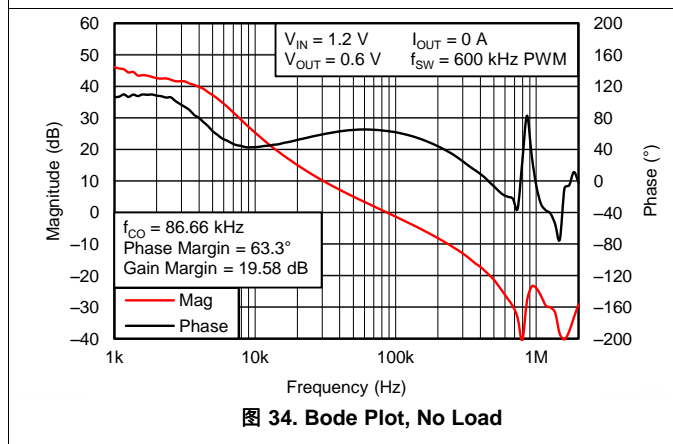

8.2.2 DDR3 SDRAM Application

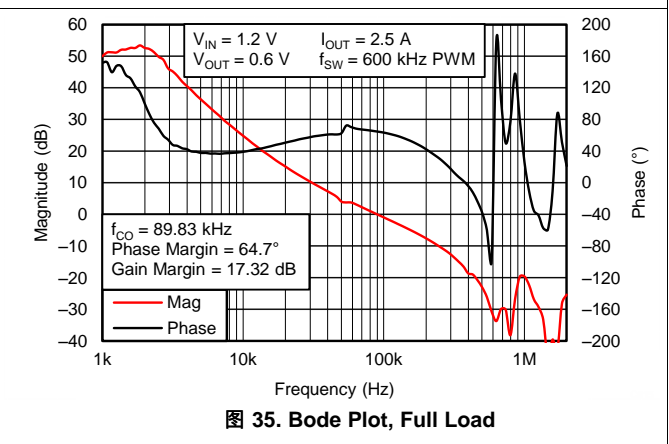
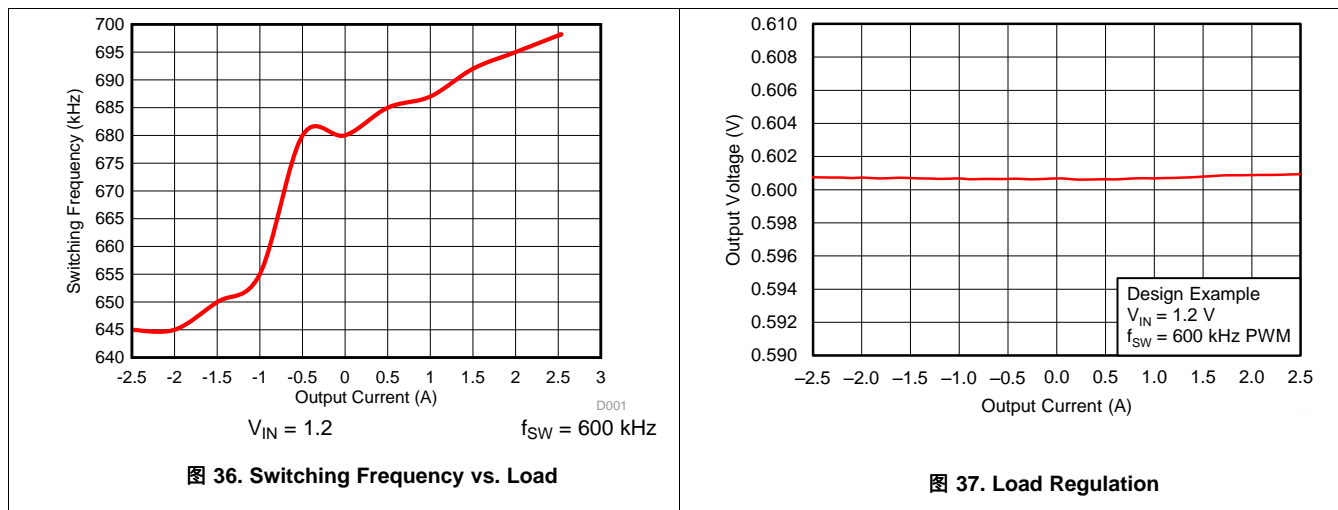

图 38. Typical Application Schematic, DDR3

8.2.2.1 Design Requirements

- $V_{IN} = 1.5\text{ V}$
- $V_{OUT} = 0.75\text{ V}$

Typical Applications (接下页)

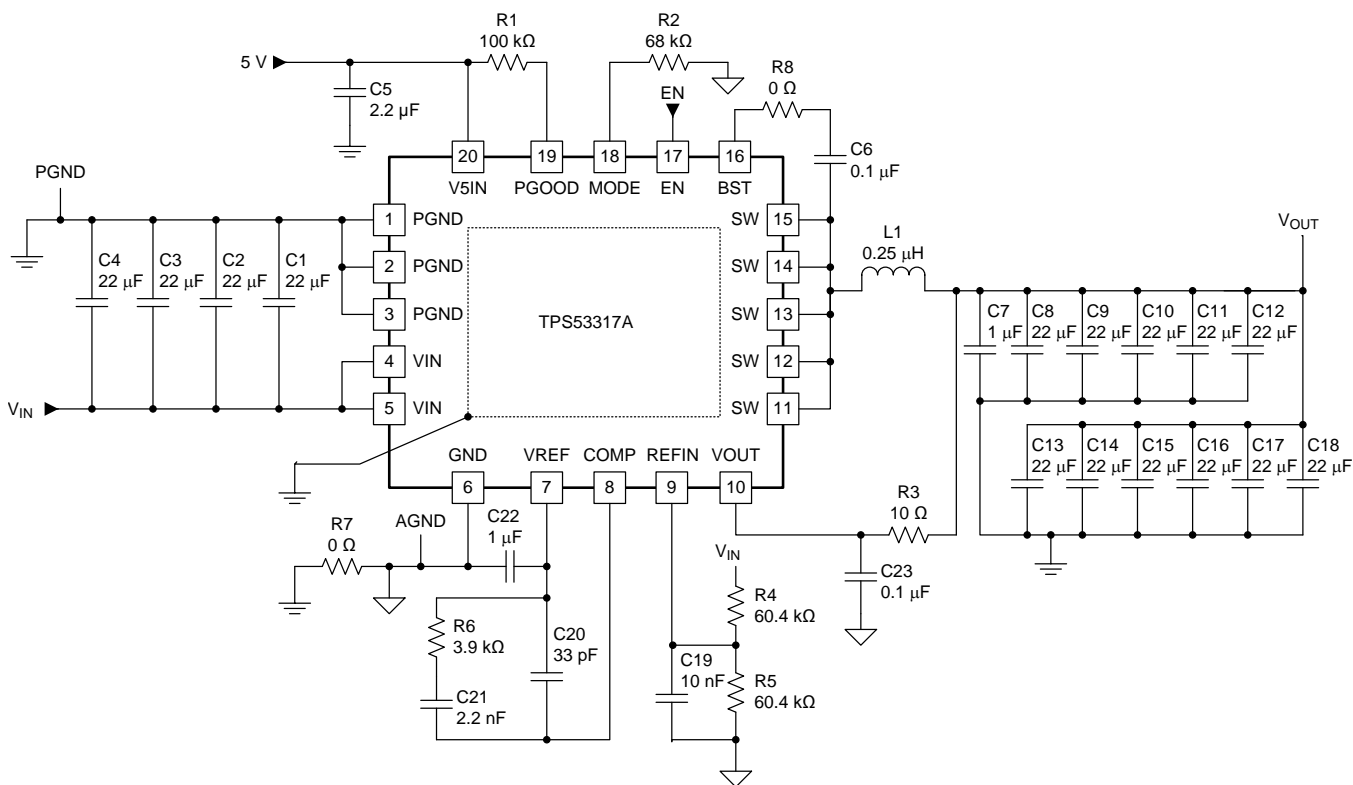
8.2.3 Non-Tracking Point-of-Load (POL) Application



图 39. Typical Application Schematic, Non-Tracking Point-of-Load (POL)

8.2.3.1 Design Requirements

- $V_{IN} = 3.3\text{ V}$
- $V_{OUT} = 1.2\text{ V}$

8.2.3.2 Application Curves

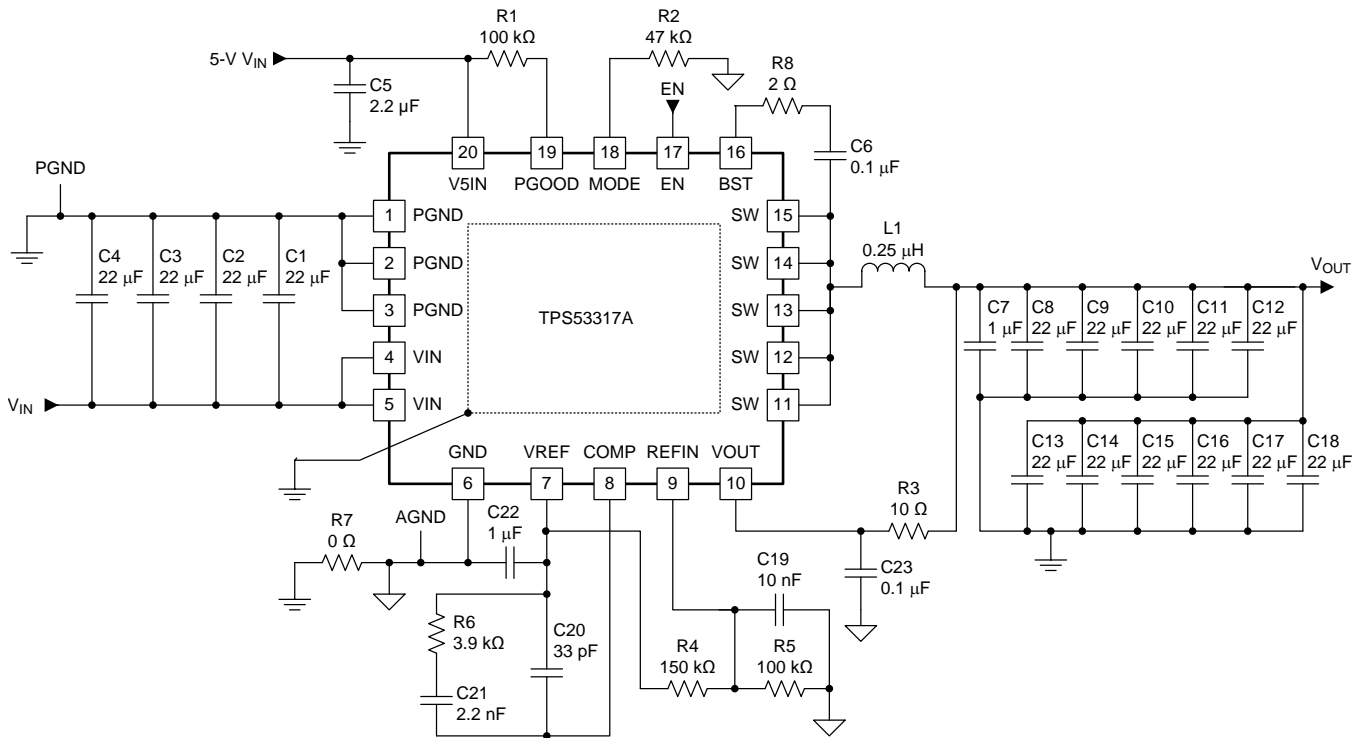

图 40. Bode Plot No Load



图 41. Bode Plot Full Load

9 Power Supply Recommendations

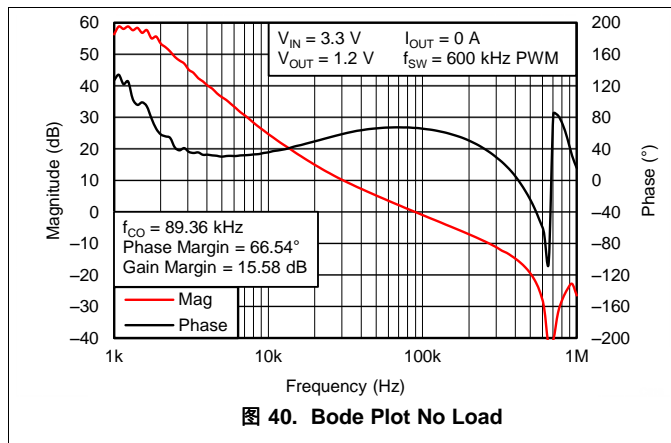
This device operates from an input voltage supply between 0.9 V and 6 V. This device requires a separate 5-V power supply for analog circuits and gate drive. Use the proper bypass capacitors for both the input supply and the 5-V supply in order to filter noise and to ensure proper device operation.

10 Layout

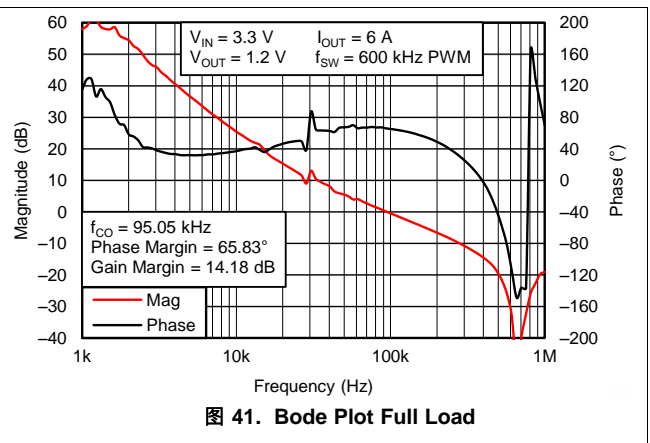
10.1 Layout Guidelines

Stable power supply operation depends on proper layout. Follow these guidelines for an optimized PCB layout.

- Connect PGND pins to the thermal pad underneath the device. Use four vias to connect the thermal pad to internal ground planes.
- Place VIN, V5IN and VREF decoupling capacitors as close to the device as possible.
- Use wide traces for the VIN, PGND and SW pins. These nodes carry high current and also serve as heat sinks.
- Place feedback and compensation components as close to the device as possible.
- Place COMP and VOUT analog signal traces away from noisy signals (SW, BST).
- The GND pin should connect to the PGND in only one place, through a via or a 0-Ω resistor.

10.2 Layout Example



图 42. TPS53317A Board Layout

11 器件和文档支持

11.1 社区资源

The following links connect to TI community resources. Linked contents are provided "AS IS" by the respective contributors. They do not constitute TI specifications and do not necessarily reflect TI's views; see TI's [Terms of Use](#).

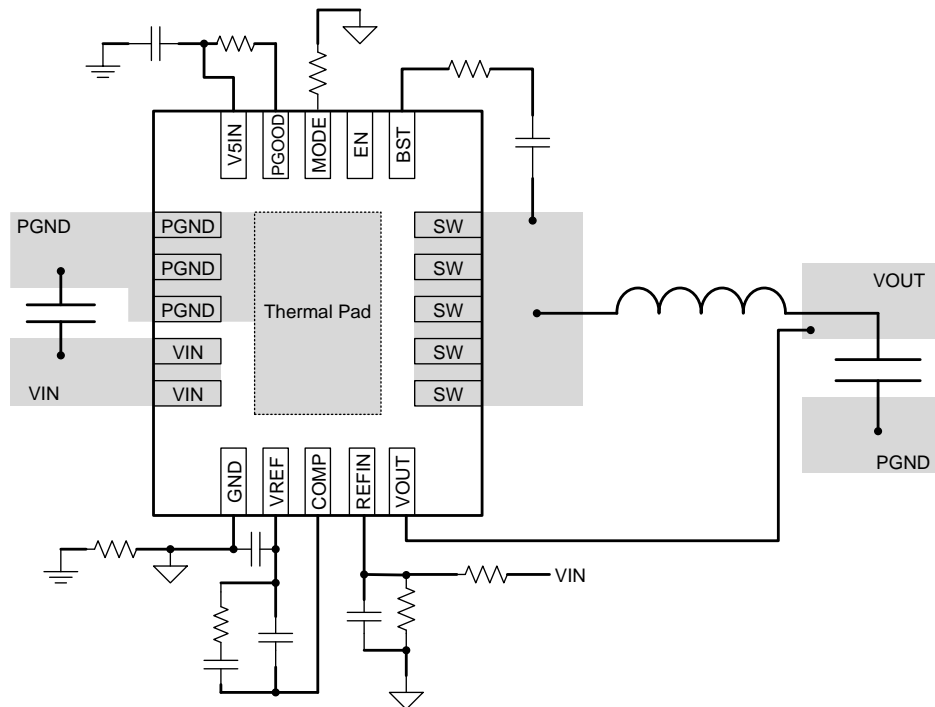
TI E2E™ Online Community *TI's Engineer-to-Engineer (E2E) Community*. Created to foster collaboration among engineers. At e2e.ti.com, you can ask questions, share knowledge, explore ideas and help solve problems with fellow engineers.

Design Support *TI's Design Support* Quickly find helpful E2E forums along with design support tools and contact information for technical support.

11.2 商标

D-CAP+, E2E are trademarks of Texas Instruments.
All other trademarks are the property of their respective owners.

11.3 静电放电警告



这些装置包含有限的内置 ESD 保护。存储或装卸时，应将导线一起截短或将装置放置于导电泡棉中，以防止 MOS 门极遭受静电损伤。

11.4 Glossary

[SLYZ022](#) — *TI Glossary*.

This glossary lists and explains terms, acronyms, and definitions.

12 机械、封装和可订购信息

以下页中包括机械、封装和可订购信息。 这些信息是针对指定器件可提供的最新数据。 这些数据会在无通知且不
对本文档进行修订的情况下发生改变。 欲获得该数据表的浏览器版本， 请查阅左侧的导航栏。

重要声明

德州仪器(TI)及其下属子公司有权根据 JESD46 最新标准,对所提供的产品和服务进行更正、修改、增强、改进或其它更改,并有权根据 JESD48 最新标准中止提供任何产品和服务。客户在下订单前应获取最新的相关信息,并验证这些信息是否完整且是最新的。所有产品的销售都遵循在订单确认时所提供的TI 销售条款与条件。

TI 保证其所销售的组件的性能符合产品销售时 TI 半导体产品销售条件与条款的适用规范。仅在 TI 保证的范围内,且 TI 认为有必要时才会使用测试或其它质量控制技术。除非适用法律做出了硬性规定,否则没有必要对每种组件的所有参数进行测试。

TI 对应用帮助或客户产品设计不承担任何义务。客户应对其使用 TI 组件的产品和应用自行负责。为尽量减小与客户产品和应用相关的风险,客户应提供充分的设计与操作安全措施。

TI 不对任何 TI 专利权、版权、屏蔽作品权或其它与使用了 TI 组件或服务的组合设备、机器或流程相关的 TI 知识产权中授予的直接或隐含权限作出任何保证或解释。TI 所发布的与第三方产品或服务有关的信息,不能构成从 TI 获得使用这些产品或服务的许可、授权、或认可。使用此类信息可能需要获得第三方的专利权或其它知识产权方面的许可,或是 TI 的专利权或其它知识产权方面的许可。

对于 TI 的产品手册或数据表中 TI 信息的重要部分,仅在没有对内容进行任何篡改且带有相关授权、条件、限制和声明的情况下才允许进行复制。TI 对此类篡改过的文件不承担任何责任或义务。复制第三方的信息可能需要服从额外的限制条件。

在转售 TI 组件或服务时,如果对该组件或服务参数的陈述与 TI 标明的参数相比存在差异或虚假成分,则会失去相关 TI 组件或服务的所有明示或暗示授权,且这是不正当的、欺诈性商业行为。TI 对任何此类虚假陈述均不承担任何责任或义务。

客户认可并同意,尽管任何应用相关信息或支持仍可能由 TI 提供,但他们将独立负责满足与其产品及其在应用中使用的 TI 产品相关的所有法律、法规和安全相关要求。客户声明并同意,他们具备制定与实施安全措施所需的全部专业技术和知识,可预见故障的危险后果、监测故障及其后果、降低有可能造成人身伤害的故障的发生机率并采取适当的补救措施。客户将全额赔偿因在此类安全关键应用中使用任何 TI 组件而对 TI 及其代理造成的任何损失。

在某些场合中,为了推进安全相关应用有可能对 TI 组件进行特别的促销。TI 的目标是利用此类组件帮助客户设计和创立其特有的可满足适用的功能安全性标准和要求的终端产品解决方案。尽管如此,此类组件仍然服从这些条款。

TI 组件未获得用于 FDA Class III (或类似的生命攸关医疗设备)的授权许可,除非各方授权官员已经达成了专门管控此类使用的特别协议。

只有那些 TI 特别注明属于军用等级或“增强型塑料”的 TI 组件才是设计或专门用于军事/航空应用或环境的。购买者认可并同意,对并非指定面向军事或航空航天用途的 TI 组件进行军事或航空航天方面的应用,其风险由客户单独承担,并且由客户独立负责满足与此类使用相关的所有法律和法规要求。

TI 已明确指定符合 ISO/TS16949 要求的产品,这些产品主要用于汽车。在任何情况下,因使用非指定产品而无法达到 ISO/TS16949 要求, TI 不承担任何责任。

	产品		应用
数字音频	www.ti.com.cn/audio	通信与电信	www.ti.com.cn/telecom
放大器和线性器件	www.ti.com.cn/amplifiers	计算机及周边	www.ti.com.cn/computer
数据转换器	www.ti.com.cn/dataconverters	消费电子	www.ti.com.cn/consumer-apps
DLP® 产品	www.dlp.com	能源	www.ti.com.cn/energy
DSP - 数字信号处理器	www.ti.com.cn/dsp	工业应用	www.ti.com.cn/industrial
时钟和计时器	www.ti.com.cn/clockandtimers	医疗电子	www.ti.com.cn/medical
接口	www.ti.com.cn/interface	安防应用	www.ti.com.cn/security
逻辑	www.ti.com.cn/logic	汽车电子	www.ti.com.cn/automotive
电源管理	www.ti.com.cn/power	视频和影像	www.ti.com.cn/video
微控制器 (MCU)	www.ti.com.cn/microcontrollers		
RFID 系统	www.ti.com.cn/rfidsys		
OMAP应用处理器	www.ti.com/omap		
无线连通性	www.ti.com.cn/wirelessconnectivity	德州仪器在线技术支持社区	www.deyisupport.com

邮寄地址: 上海市浦东新区世纪大道1568号, 中建大厦32楼邮政编码: 200122
Copyright © 2015, 德州仪器半导体技术(上海)有限公司

PACKAGING INFORMATION

Orderable Device	Status (1)	Package Type	Package Drawing	Pins	Package Qty	Eco Plan (2)	Lead finish/ Ball material (6)	MSL Peak Temp (3)	Op Temp (°C)	Device Marking (4/5)	Samples
TPS53317ARGBR	ACTIVE	VQFN	RGB	20	3000	RoHS & Green	NIPDAU	Level-2-260C-1 YEAR	-40 to 125	53317A	Samples
TPS53317ARGBT	ACTIVE	VQFN	RGB	20	250	RoHS & Green	NIPDAU	Level-2-260C-1 YEAR	-40 to 125	53317A	Samples

(1) The marketing status values are defined as follows:

ACTIVE: Product device recommended for new designs.

LIFEBUY: TI has announced that the device will be discontinued, and a lifetime-buy period is in effect.

NRND: Not recommended for new designs. Device is in production to support existing customers, but TI does not recommend using this part in a new design.

PREVIEW: Device has been announced but is not in production. Samples may or may not be available.

OBSELETE: TI has discontinued the production of the device.

(2) **RoHS:** TI defines "RoHS" to mean semiconductor products that are compliant with the current EU RoHS requirements for all 10 RoHS substances, including the requirement that RoHS substance do not exceed 0.1% by weight in homogeneous materials. Where designed to be soldered at high temperatures, "RoHS" products are suitable for use in specified lead-free processes. TI may reference these types of products as "Pb-Free".

RoHS Exempt: TI defines "RoHS Exempt" to mean products that contain lead but are compliant with EU RoHS pursuant to a specific EU RoHS exemption.

Green: TI defines "Green" to mean the content of Chlorine (Cl) and Bromine (Br) based flame retardants meet JS709B low halogen requirements of <=1000ppm threshold. Antimony trioxide based flame retardants must also meet the <=1000ppm threshold requirement.

(3) MSL, Peak Temp. - The Moisture Sensitivity Level rating according to the JEDEC industry standard classifications, and peak solder temperature.

(4) There may be additional marking, which relates to the logo, the lot trace code information, or the environmental category on the device.

(5) Multiple Device Markings will be inside parentheses. Only one Device Marking contained in parentheses and separated by a "~" will appear on a device. If a line is indented then it is a continuation of the previous line and the two combined represent the entire Device Marking for that device.

(6) Lead finish/Ball material - Orderable Devices may have multiple material finish options. Finish options are separated by a vertical ruled line. Lead finish/Ball material values may wrap to two lines if the finish value exceeds the maximum column width.

Important Information and Disclaimer:The information provided on this page represents TI's knowledge and belief as of the date that it is provided. TI bases its knowledge and belief on information provided by third parties, and makes no representation or warranty as to the accuracy of such information. Efforts are underway to better integrate information from third parties. TI has taken and continues to take reasonable steps to provide representative and accurate information but may not have conducted destructive testing or chemical analysis on incoming materials and chemicals. TI and TI suppliers consider certain information to be proprietary, and thus CAS numbers and other limited information may not be available for release.

In no event shall TI's liability arising out of such information exceed the total purchase price of the TI part(s) at issue in this document sold by TI to Customer on an annual basis.

RGB (R-PVQFN-N20)

PLASTIC QUAD FLATPACK NO-LEAD

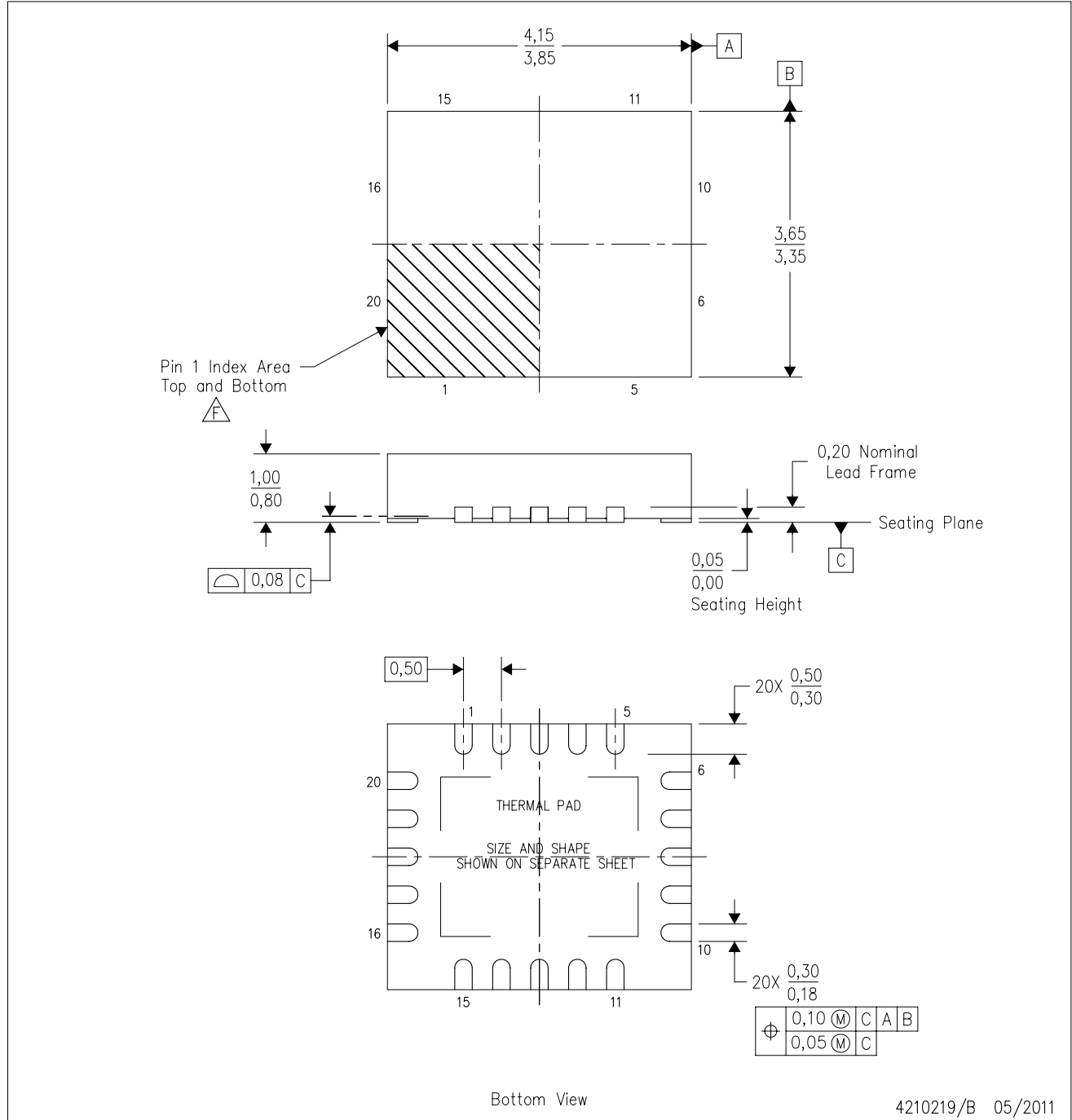

4210219/B 05/2011

- NOTES:
- A. All linear dimensions are in millimeters. Dimensioning and tolerancing per ASME Y14.5M-1994.
 - B. This drawing is subject to change without notice.
 - C. QFN (Quad Flatpack No-Lead) package configuration.
 - D. The package thermal pad must be soldered to the board for thermal and mechanical performance.
 - E. See the additional figure in the Product Data Sheet for details regarding the exposed thermal pad features and dimensions.
- F** Pin 1 identifiers are located on both top and bottom of the package and within the zone indicated. The Pin 1 identifiers are either a molded, marked, or metal feature.

THERMAL PAD MECHANICAL DATA

RGB (R-PVQFN-N20)

PLASTIC QUAD FLATPACK NO-LEAD

THERMAL INFORMATION

This package incorporates an exposed thermal pad that is designed to be attached directly to an external heatsink. The thermal pad must be soldered directly to the printed circuit board (PCB). After soldering, the PCB can be used as a heatsink. In addition, through the use of thermal vias, the thermal pad can be attached directly to the appropriate copper plane shown in the electrical schematic for the device, or alternatively, can be attached to a special heatsink structure designed into the PCB. This design optimizes the heat transfer from the integrated circuit (IC).

For information on the Quad Flatpack No-Lead (QFN) package and its advantages, refer to Application Report, QFN/SON PCB Attachment, Texas Instruments Literature No. SLUA271. This document is available at www.ti.com.

The exposed thermal pad dimensions for this package are shown in the following illustration.

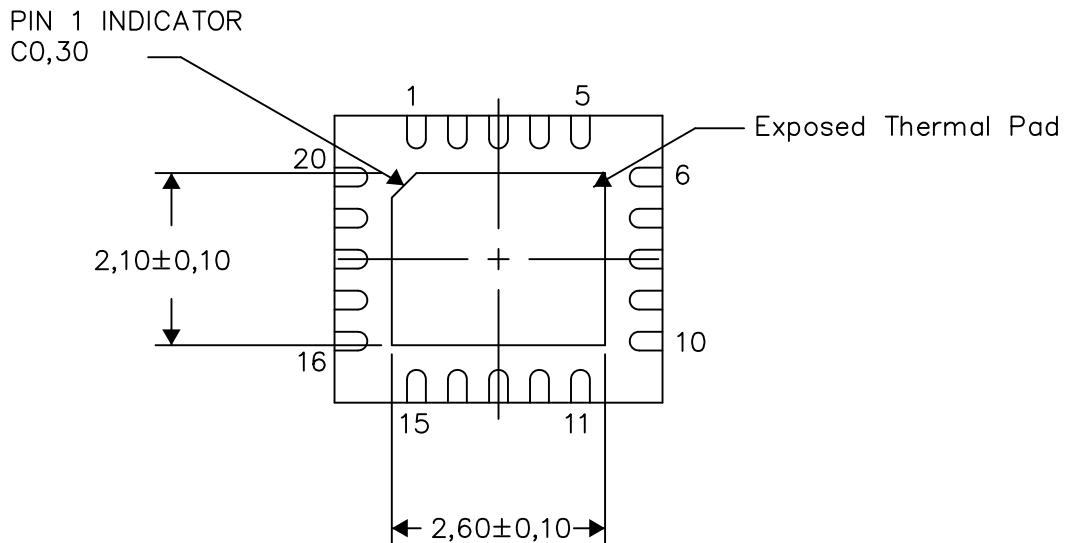

Bottom View

Exposed Thermal Pad Dimensions

4210242/C 05/12

NOTE: All linear dimensions are in millimeters

RGB (R-PVQFN-N20)

PLASTIC QUAD FLATPACK NO-LEAD

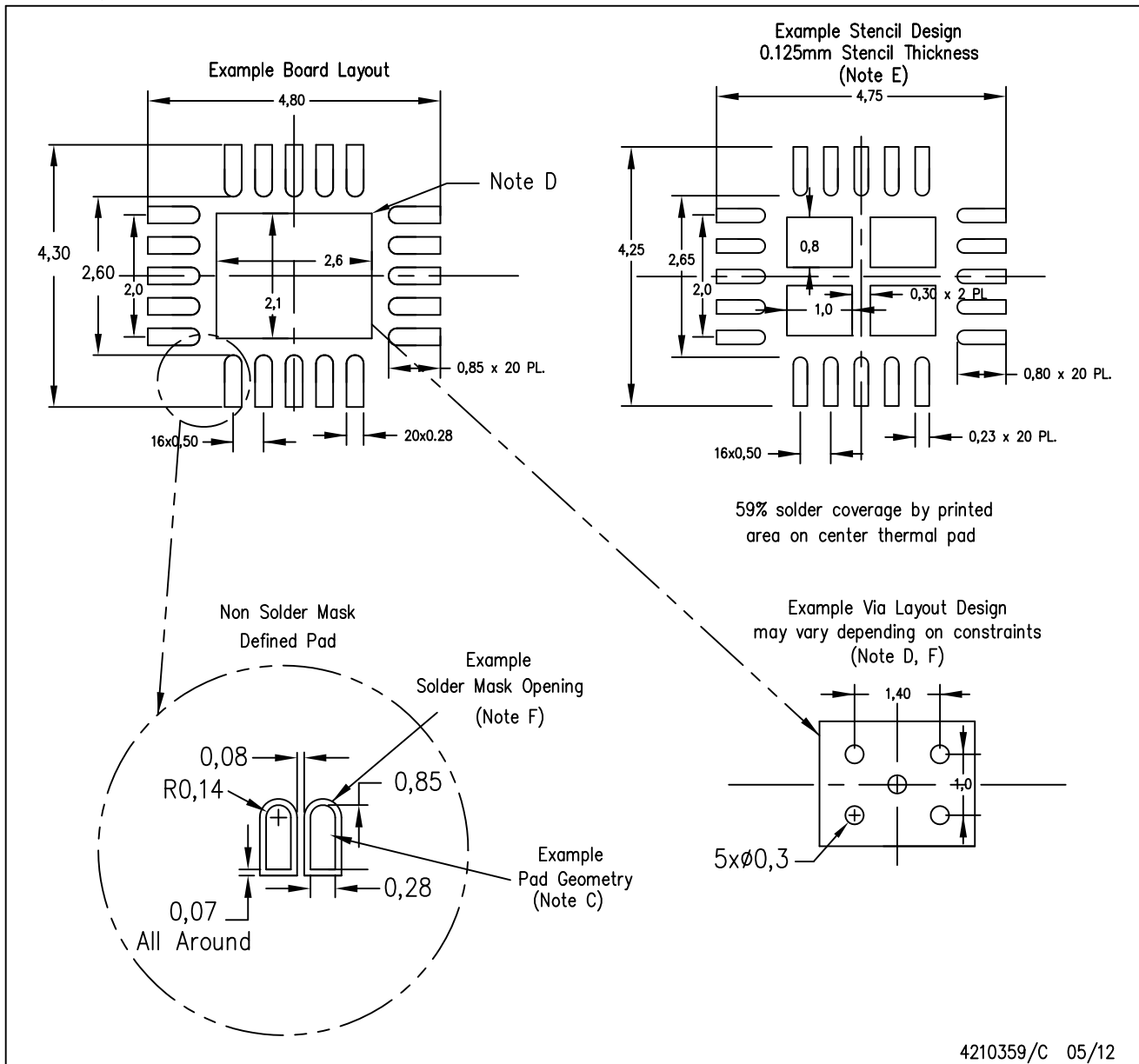

4210359/C 05/12

- NOTES:
- A. All linear dimensions are in millimeters.
 - B. This drawing is subject to change without notice.
 - C. Publication IPC-7351 is recommended for alternate designs.
 - D. This package is designed to be soldered to a thermal pad on the board. Refer to Application Note, Quad Flat-Pack QFN/SON PCB Attachment, Texas Instruments Literature No. SLUA271, and also the Product Data Sheets for specific thermal information, via requirements, and recommended board layout. These documents are available at www.ti.com <<http://www.ti.com>>.
 - E. Laser cutting apertures with trapezoidal walls and also rounding corners will offer better paste release. Customers should contact their board assembly site for stencil design recommendations. Refer to IPC 7525 for stencil design considerations.
 - F. Customers should contact their board fabrication site for minimum solder mask web tolerances between signal pads.

重要声明和免责声明

TI 均以“原样”提供技术性及其可靠性数据（包括数据表）、设计资源（包括参考设计）、应用或其他设计建议、网络工具、安全信息和其他资源，不保证其中不含任何瑕疵，且不做任何明示或暗示的担保，包括但不限于对适销性、适合某特定用途或不侵犯任何第三方知识产权的暗示担保。

所述资源可供专业开发人员应用TI 产品进行设计使用。您将对以下行为独自承担全部责任：(1) 针对您的应用选择合适的TI 产品；(2) 设计、验证并测试您的应用；(3) 确保您的应用满足相应标准以及任何其他安全、安保或其他要求。所述资源如有变更，恕不另行通知。TI 对您使用所述资源的授权仅限于开发资源所涉及TI 产品的相关应用。除此之外不得复制或展示所述资源，也不提供其它TI 或任何第三方的知识产权授权许可。如因使用所述资源而产生任何索赔、赔偿、成本、损失及债务等，TI 对此概不负责，并且您须赔偿由此对TI 及其代表造成的损害。

TI 所提供产品均受TI 的销售条款 (<http://www.ti.com.cn/zh-cn/legal/termsofsale.html>) 以及ti.com.cn上或随附TI产品提供的其他可适用条款的约束。TI提供所述资源并不扩展或以其他方式更改TI 针对TI 产品所发布的可适用的担保范围或担保免责声明。

邮寄地址：上海市浦东新区世纪大道 1568 号中建大厦 32 楼，邮政编码：200122

Copyright © 2020 德州仪器半导体技术（上海）有限公司