

带有集成场效应晶体管 (FET) 的 3.1V 至 5.5V 输入, 3A 输出, 同步, 降压稳压器

 查询样品: [TPS51312](#)

特性

- **D-CAP2™** 模式支持快速瞬态响应
- 无需外部补偿
- 输入电压 **V_{IN}** 范围: **3.1V 至 5.5V**
- 偏置电压 **V_{CC}** 范围: **3.1V 至 5.5V**
- 输出电压范围: **0.6V 至 3.3V**
- **0.6V, 1%** 电压基准精度
- 固定电压伺服器软启动功能
- 自动跳跃, **Eco-mode™** 用于在轻负载时实现高效率
- 开关频率: **900kHz**
- 欠压闭锁 (**UVLO**), 欠压保护 (**UVP**), 过热保护 (**OTP**) 和过压保护 (**OVP**) 电源正常输出
- 逐周期电流限制, 锁存过流保护 (**OCP**)
- 耐热增强型 **3mm x 3mm, 10 引脚小外形尺寸无引线 (SON) (DRC)** 封装

应用范围

- 电池供电类设备
- 笔记本电脑

说明

TPS51312 是一款高效、同步、降压 DC/DC 转换器。它在输出电压范围为 0.6V 至 3.3V 时的输出电流为 3A (最大值)。D-CAP2 适应启动时间控制可在使用全陶瓷输出电容器设计时实现小封装尺寸并提供低外部组件数量。此器件还特有轻负载条件下的自动跳跃功能、预偏置启动和内部固定软启动时间。当器件被禁用时, 输出电容器通过内部电阻器放电。

TPS51312 采用 3mm x 3mm, 10 引脚 DRC 封装 (符合 RoHs 绿色环保标准且无铅), 额定温度范围为 -40°C 至 85°C。

简化的应用

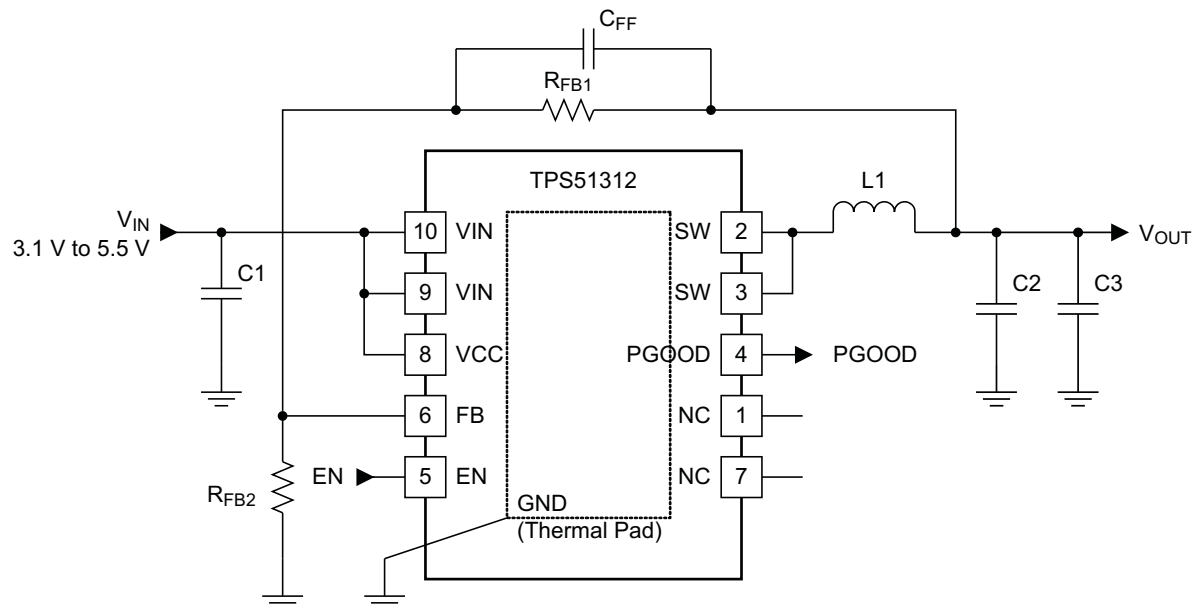

UDG-12125



Please be aware that an important notice concerning availability, standard warranty, and use in critical applications of Texas Instruments semiconductor products and disclaimers thereto appears at the end of this data sheet.

D-CAP2, Eco-mode are trademarks of Texas Instruments.
All other trademarks are the property of their respective owners.

TPS51312

ZHCSAE3 –SEPTEMBER 2012

www.ti.com.cn



This integrated circuit can be damaged by ESD. Texas Instruments recommends that all integrated circuits be handled with appropriate precautions. Failure to observe proper handling and installation procedures can cause damage.

ESD damage can range from subtle performance degradation to complete device failure. Precision integrated circuits may be more susceptible to damage because very small parametric changes could cause the device not to meet its published specifications.

ORDERING INFORMATION⁽¹⁾

T _A	PACKAGE	ORDERABLE DEVICE NUMBER	PINS	OUTPUT SUPPLY	MINIMUM QUANTITY	ECO PLAN
-40°C to 85°C	Plastic SON (DRC)	TPS51312DRCR	10	Tape and reel	3000	Green (RoHS and no Pb/Br)
		TPS51312DRCT		Mini reel	250	

(1) For the most current package and ordering information see the Package Option Addendum at the end of this document, or see the TI web site at www.ti.com.

ABSOLUTE MAXIMUM RATINGS⁽¹⁾

		VALUE		UNIT
		MIN	MAX	
Input voltage range ⁽²⁾	VIN, VCC, EN	-0.3	6.0	V
	SW	-2.0	6.0	
	SW (transient 20 ns)	-3.0	8.5	
	FB	-1	3.6	
Output voltage range ⁽²⁾	PGOOD	-0.3	6.0	V
Junction temperature, T _J			125	°C
Storage temperature, T _{stg}		-55	150	°C

- (1) Stresses beyond those listed under "absolute maximum ratings" may cause permanent damage to the device. These are stress ratings only and functional operation of the device at these or any other conditions beyond those indicated under "recommended operating conditions" is not implied. Exposure to absolute-maximum-rated conditions for extended periods may affect device reliability.
- (2) All voltage values are with respect to the network ground terminal unless otherwise noted.

THERMAL INFORMATION

THERMAL METRIC ⁽¹⁾		TPS51312	UNITS
		DRC (10-PIN)	
θ _{JA}	Junction-to-ambient thermal resistance	42.4	°C/W
θ _{JCtop}	Junction-to-case (top) thermal resistance	53.9	
θ _{JB}	Junction-to-board thermal resistance	18.1	
ψ _{JT}	Junction-to-top characterization parameter	1.1	
ψ _{JB}	Junction-to-board characterization parameter	18.3	
θ _{JCbot}	Junction-to-case (bottom) thermal resistance	6.3	

(1) 有关传统和新的热 度量的更多信息，请参阅 IC 封装热度量应用报告，SPRA953。

RECOMMENDED OPERATING CONDITIONS

		MIN	MAX	UNIT
Input voltage range	VIN, VCC, SW, EN	-0.1	5.5	V
	FB	-0.1	3.5	
Output voltage range	PGOOD	-0.1	5.5	V
Operating free-air temperature, T _A		-40	85	°C

ELECTRICAL CHARACTERISTICS

Over operating free-air temperature range, $V_{IN} = 5\text{ V}$, $V_{CC} = 5\text{ V}$, $V_{EN} = 3.3\text{ V}$ (unless otherwise noted).

PARAMETER		TEST CONDITION	MIN	TYP	MAX	UNIT
SUPPLY VOLTAGE						
V_{IN}	Supply voltage		3.1		5.5	V
V_{CC}	Supply voltage		3.1		5.5	V
SUPPLY CURRENT						
I_{IN}	Input voltage supply current	EN = High			100	μA
I_{SD}	Input voltage shutdown current	EN = Low			12	μA
$I_{VCC(in)}$	VCC supply current	EN = High		700		μA
$I_{VCC(sd)}$	VCC shutdown current	EN = Low, $T_A = 25^\circ\text{C}$			20	μA
VFB REFERENCE VOLTAGE						
V_{FBREF}	Reference voltage			0.6		V
$V_{FBREFTOL}$	Reference voltage tolerance	$T_A = 25^\circ\text{C}$	-1%		1%	
I_{FB}	Feedback pin leakage current		-100		100	nA
SMPS FREQUENCY						
f_{SW}	Switching frequency			0.9		MHz
$t_{OFF(min)}$	Minimum off-time		110	190	270	ns
t_{DEAD}	Dead time ⁽¹⁾	SW node high, $V_{IN} = 5\text{ V}$		9		ns
		SW node low, $V_{IN} = 5\text{ V}$		10		
LOGIC THRESHOLD AND CURRENT						
V_{LL}	EN low-level voltage				0.8	V
V_{LH}	EN high-level voltage		1.5			V
I_{LLK}	EN input leakage current	$V_{IN} = V_{CC} = 3.3\text{ V}$	-3	1	3	μA
MOSFET						
$R_{DS(on)_H}$	On-resistance ⁽¹⁾	$V_{IN} = 5\text{ V}$		81		m Ω
		$V_{IN} = 5\text{ V}$		41		
SOFT-START						
t_{SS}	Soft-start time ⁽¹⁾	V_{FB} rising from 0 V to 0.6 V		300		μs
PGOOD COMPARATOR						
V_{PGTH}	PGOOD threshold	PGOOD out to higher w/r/t V_{FB}		130%		
		PGOOD out to lower w/r/t V_{FB}		50%		
t_{PGDLY}	PGOOD high delay time	Delay for PGOOD in, after EN = Hi		1.3		ms
I_{PGLK}	PGOOD leakage current		-1	0	1	μA
PROTECTIONS						
I_{OCL}	Current limit threshold	Valley current limit, $V_{IN} = V_{CC} = 3.3\text{ V}$, $T_A = 25^\circ\text{C}$	4.8			A
V_{IN_UVLO}	VIN UVLO threshold voltage	Wake-up	2.85	2.95	3.05	V
		Shutdown	2.6	2.7	2.8	
V_{CC_UVLO}	VCC UVLO threshold voltage	Wake-up	2.85	2.95	3.05	V
		Shutdown	2.6	2.7	2.8	
V_{OVP}	OVP threshold voltage	OVP detect		130%		
t_{OVP}	OVP delay time	Overdrive = 100 mV		1.9		μs
V_{UVP}	UVP threshold voltage	UVP detect		50%		
t_{UVPDLY}	UVP delay time	Overdrive = 100 mV		2.4		μs

(1) Specified by design. Not production tested.

TPS51312

ZHCSAE3 –SEPTEMBER 2012

www.ti.com.cn

ELECTRICAL CHARACTERISTICS (continued)

Over operating free-air temperature range, $V_{IN} = 5\text{ V}$, $V_{CC} = 5\text{ V}$, $V_{EN} = 3.3\text{ V}$ (unless otherwise noted).

PARAMETER	TEST CONDITION	MIN	TYP	MAX	UNIT
SW PULL-DOWN RESISTANCE					
R_{SWPD}	SW pull-down resistance	EN = Lo		260	Ω
THERMAL SHUTDOWN					
T_{SDN}	Thermal shutdown threshold ⁽²⁾	Shutdown temperature		145	$^{\circ}\text{C}$
		Hysteresis		20	

(2) Specified by design. Not production tested.

DEVICE INFORMATION FUNCTIONAL BLOCK DIAGRAM

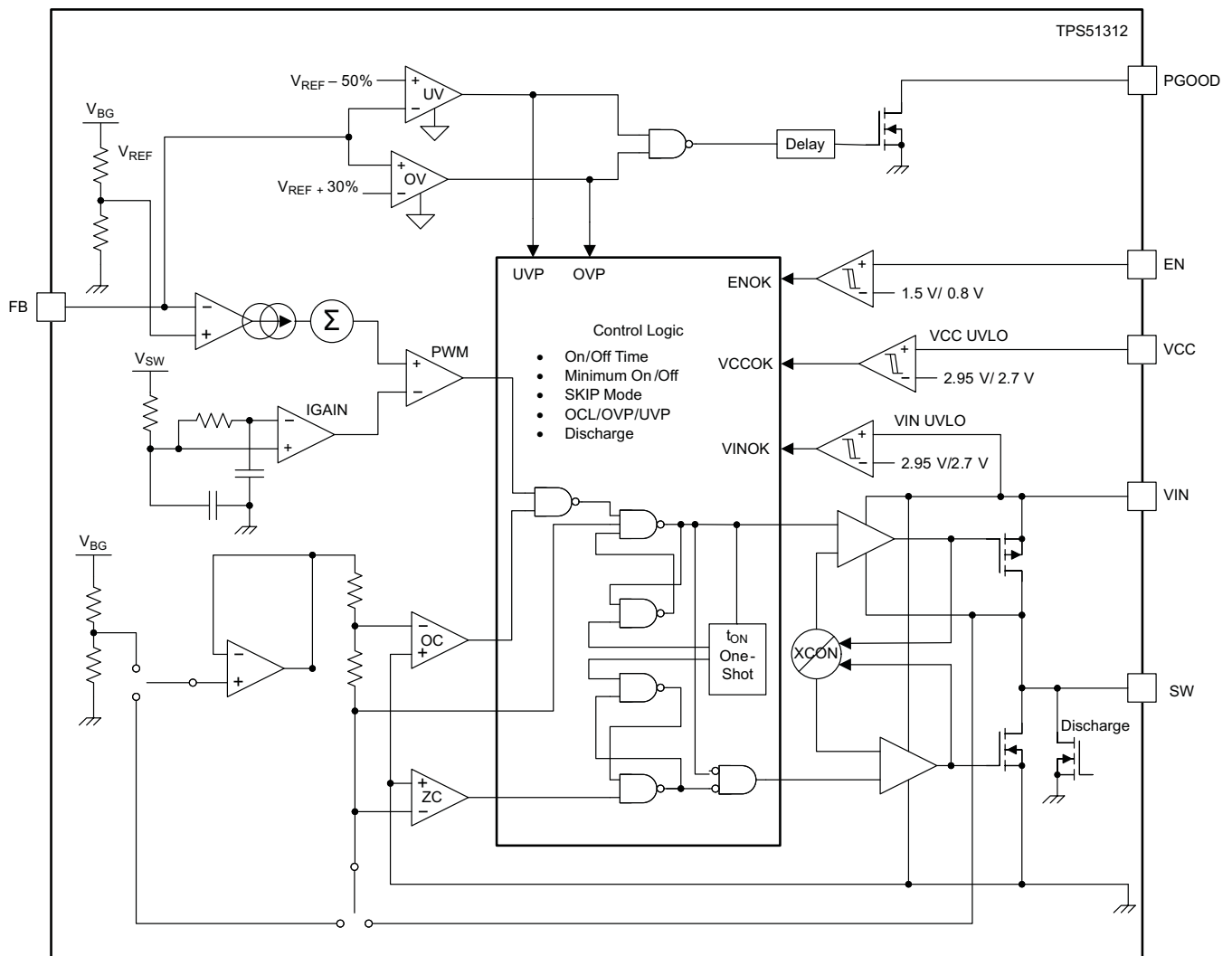

UDG-12124

**DRC PACKAGE
10 PINS
(TOP VIEW)**

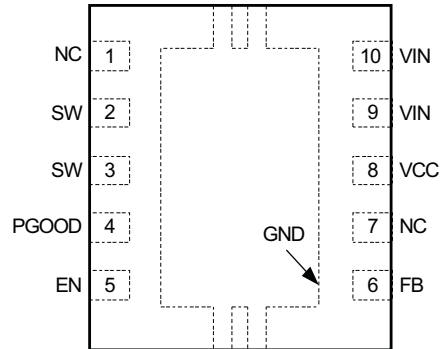

PIN FUNCTIONS

PIN		I/O	DESCRIPTION
NAME	NO.		
EN	5	I	Enable function for the switched-mode power supply (SMPS) (3.3-V logic compatible)
FB	6	I	Voltage feedback. Also used for OVP, UVP and PGOOD determination.
NC	1 7	–	No connection. Make no external connection to this pin.
PGOOD	4	O	Power good indicator. Requires external pull-up resistor.
SW	2 3	I	Switching node output. Connect to external inductor. Also serve as current sensing negative input for over current protection purpose
VCC	8	I	Power supply for analog circuit.
VIN	9 10	I	Main power conversion input and gate-drive voltage supply for output FETs.
Thermal Pad		I	Ground terminal.

TYPICAL CHARACTERISTICS

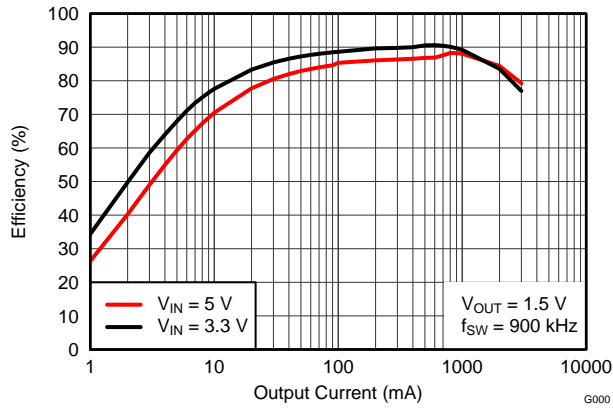

Figure 1. Efficiency vs. Output Current

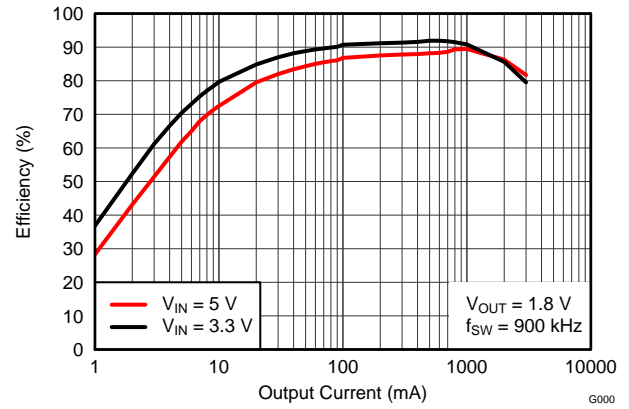

Figure 2. Efficiency vs. Output Current

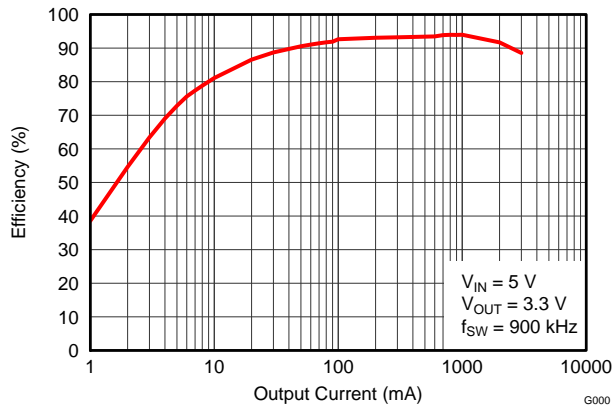

Figure 3. Efficiency vs. Output Current

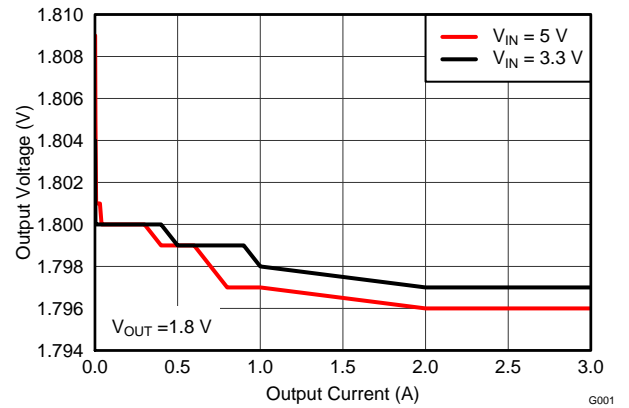

Figure 4. DC Load Regulation

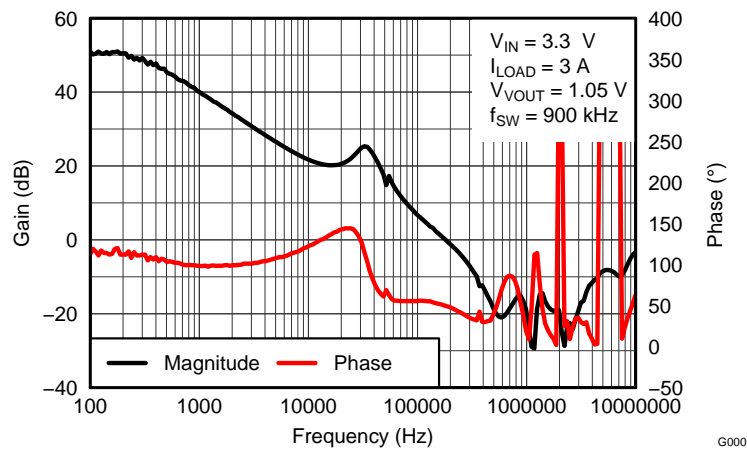

Figure 5. Bode Plot

TYPICAL CHARACTERISTICS (continued)

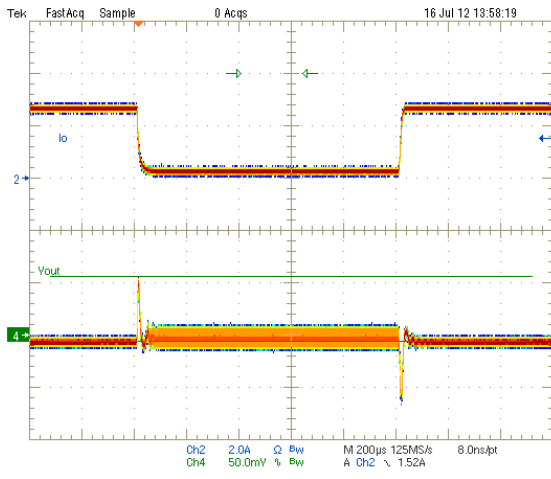

Figure 6. 3.3-V Input, 1.8-V Output from 0 A to 3 A

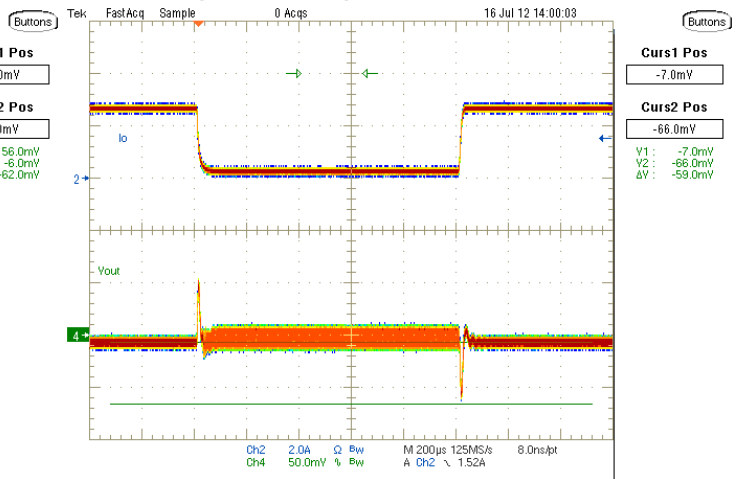

Figure 7. 5-V Input, 1.8-V Output from 0 A to 3 A

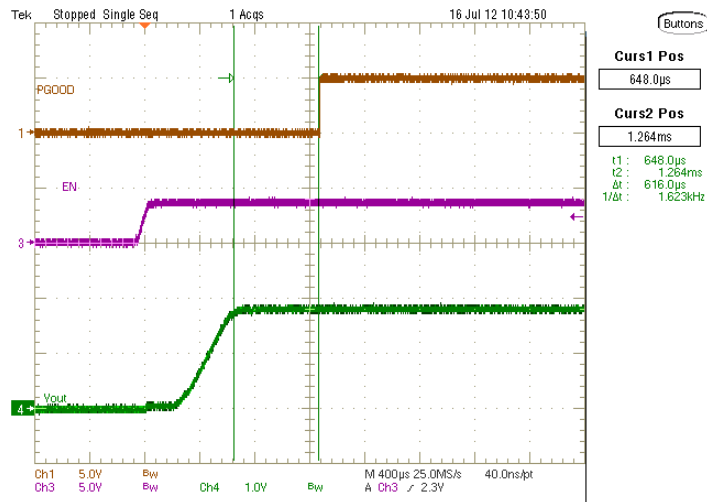

Figure 8. 5-V Input, 1.8-V Output Start-Up

APPLICATION INFORMATION

Functional Overview

TPS51312 is a D-CAP2 mode adaptive on time converter with internal integrator. Monolithically integrate high side and low side FET supports output current to a maximum of 3-ADC. The converter automatically runs in discontinuous conduction mode to optimize light load efficiency. A switching frequency of 900 kHz enables optimization of the power train for the cost, size and efficiency performance of the design.

PWM Operation

The PWM operation is comprised of three separate loops, A, B and C as shown in Figure 9.

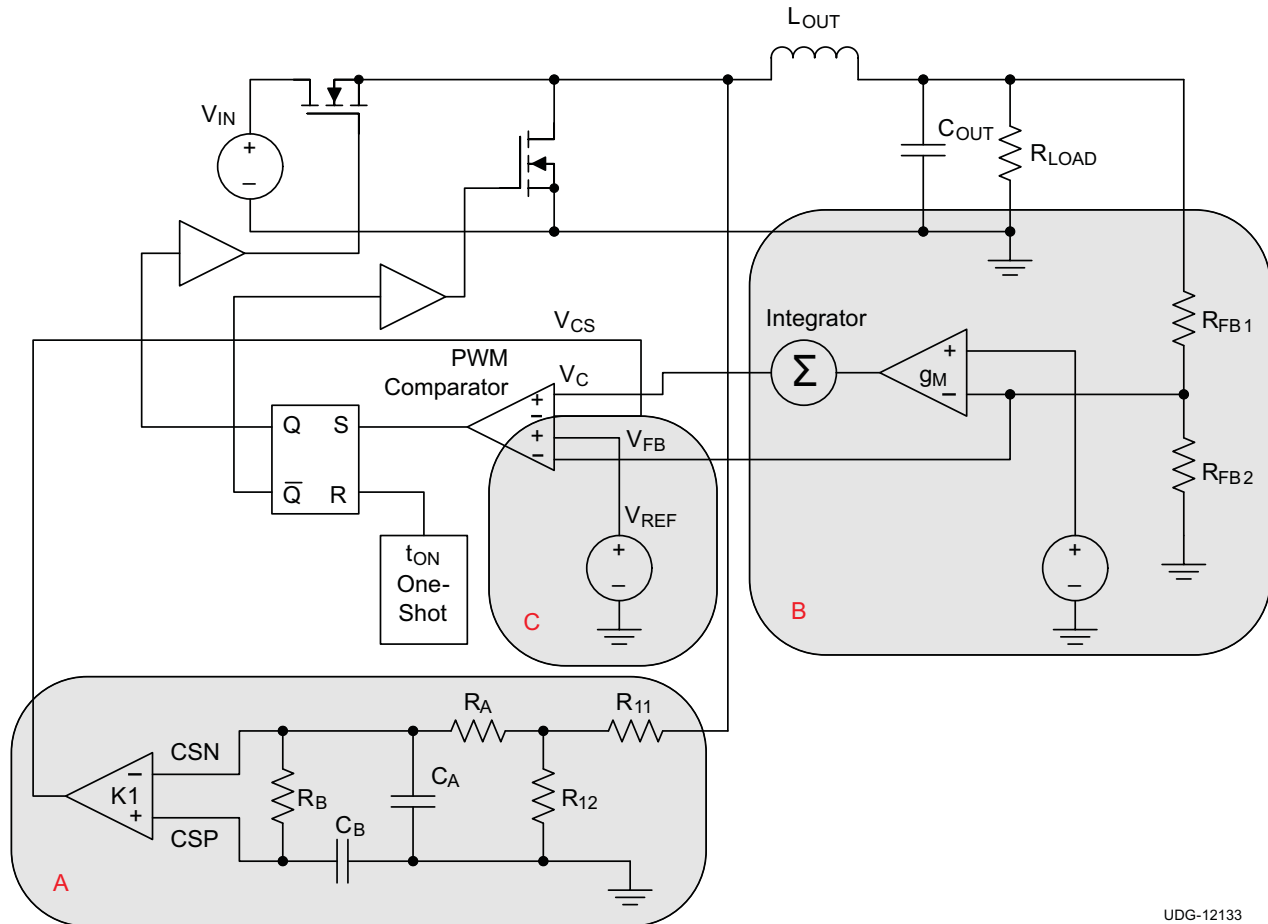

UDG-12133

Figure 9. $\frac{3}{4}$ PWM Operation

Internal Current Loop (A)

Loop A is the internal current loop. The current information is sampled, divided and averaged at the SW node. The RC time constant and the gain of the current sense amplifier is chosen to cover the wide range of power stage design intended for this application.

Internal Voltage Loop (B)

Loop B is the internal voltage loop. The feedback voltage information is compared to the voltage reference at the input of the g_M amplifier, the internal integrator is designed to provide a zero at the double pole location to boost phase margin at the desired crossover frequency.

Fast Feedforward Loop (C)

Loop C is the additional loop that acts a direct fast feedforward loop to enhance the transient response.

In steady state operation as shown in Figure 10, the on time is initiated by the interaction of the three loops mentioned above. When the $(V_C - V_{CS})$ is rising above threshold defined by $(V_{FB} - V_{REF})$, the PWM comparator issues the on time pulse after the propagation delay. The demand of on time occurs when the artificial current has reached the valley point. The load regulation is maintained by the integrator provided by the g_M amplifier and integrator.

In transient operation as shown in Figure 11, the benefit of this topology is becoming evident. In an all MLCC output configuration, especially when the output capacitance is low, when the load step is applied, the output voltage is immediately discharged to try to keep the load demand. The immediate reflection of the load demand is instantly reflected in the FB voltage. The $(V_{FB} - V_{REF})$ is thus served as a termination voltage level for the $(V_C - V_{CS})$, thus modulating the initiation of the on time. The transient response can be improved further by amplifying the difference between V_{FB} and the V_{REF} reference.

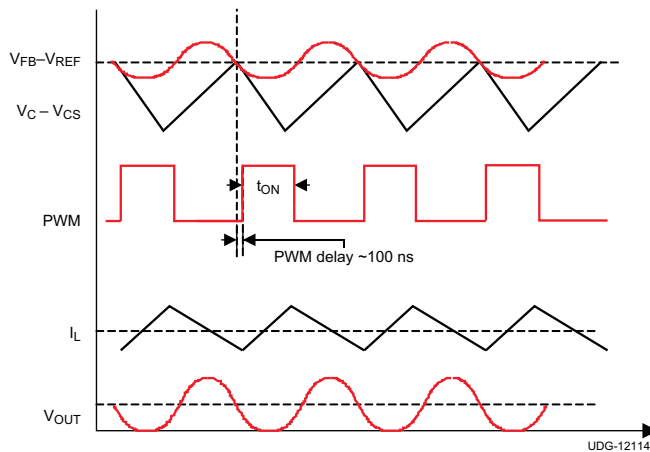

Figure 10. Steady-State Operation

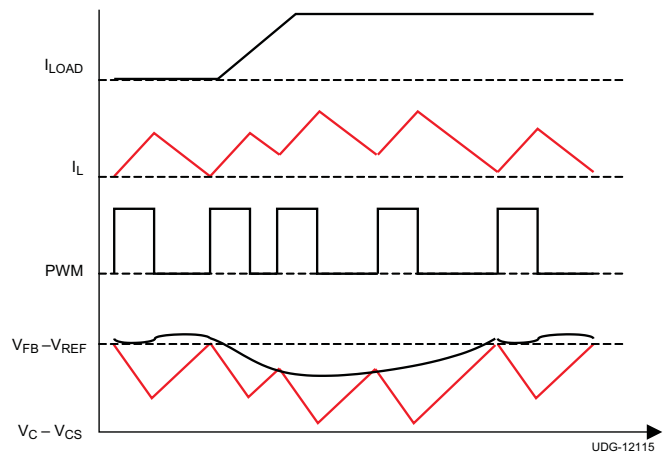

Figure 11. Transient Operation

PWM Frequency

The TPS51312 operates at a switching frequency of 900 kHz.

Light Load Power Saving Features

The TPS51312 offers an automatic pulse-skipping feature to provide excellent efficiency over the entire load range. The converter senses the current during low side FET on and prevents negative current flow by turning off the low side FET. This saves power by eliminating re-circulation of the inductor current. When the bottom FET is turned off, the converter enters discontinuous mode, and the switching frequency decreases, reducing switching loss.

Power Sequences

TPS51312 initiates the soft-start process when the EN, VIN and VCC pins are ready. The soft-start time 300 μ s when the reference voltage is between 0 V and 0.6 V (V_{REF}). The actual voltage ramp up time is the same as that of the V_{REF} start-up time, which is 300 μ s.

Power Good Signal

The TPS51312 has one open-drain power good (PGOOD) pin. During initial startup, there is a 1.3-ms power good high propagation delay after EN goes high. The PGOOD de-asserts when the EN is pulled low or an undervoltage condition on VCC or VIN or any other faults (such as V_{OUT} , UVP, OCP, OVP) that require latch off action is detected.

Protection Features

The TPS51312 offers many features to protect the converter power chain as well as the system electronics.

Input Undervoltage Protection on V_{CC} and V_{IN} (UVLO)

The TPS51312 continuously monitor the voltage on the V_{CC} and V_{IN} to ensure the voltage level is high enough to bias the converter properly and to provide sufficient gate drive potential to maintain high efficiency for the converter. The converter starts with V_{CC} and V_{IN} approximately 2.95 V and has a nominal of 250 mV of hysteresis, assuming EN is above the logic threshold level. If the UVLO level is reached for either V_{CC} or V_{IN} , the converter transitions the SW node into a tri-state and remains off until the device is reset by both V_{CC} and V_{IN} reaches 2.95 V (nominal). The PGOOD is deasserted when UVLO is detected and remains low until the device is reset.

Output Overvoltage Protection (OVP)

The TPS51312 has OVP protection circuit. An OVP event is detected when the FB voltage is approximately $130\% \times 0.6V_{REF}$. In this case, the converter de-asserts the PGOOD signal and performs the overvoltage protection function. The converter latches off both high-side and low-side FET and remains in this state after a delay of 1.9 μ s (typ) until the device is reset by EN, or V_{CC} or V_{IN} .

Output Undervoltage Protection (UVP)

Output undervoltage protection works in conjunction with the current protection described in the [Overcurrent and Current Limit Protection](#) section. If the FB voltage drops below $50\% \times 0.6 V_{REF}$, after a delay of 2.4 μ s (typ), the converter latches off. Undervoltage protection can be reset by EN, V_{CC} or V_{IN} .

Overcurrent and Current Limit Protection

The TPS51312 provides an overcurrent protection function. The nominal OCP is 4.8-A DC. When the current limit is exceeded for consecutive 9 cycles, the converter latches off and remains latched off until it is reset by EN, V_{CC} or V_{IN} .

The TPS51312 also provides current limit protection function. If the sense current is above the OCL setting, the converter delays the next on pulse until the current level drops below the OCL limit. Current limiting occurs on a pulse-by-pulse basis. During a fast or very fast overcurrent event, the output voltage tends to droop until the UVP limit is reached. Then the converter de-asserts the PGOOD signal, and latches off after a typical delay time of 2.4 μ s. The converter remains in this state until the device is reset by EN, V_{CC} or V_{IN} .

Thermal Protection

The TPS51312 has an internal temperature sensor. When the die temperature reaches a nominal of 145°C, the device shuts down until the temperature cools by approximately 20°C. Then the converter restarts. The thermal shutdown is a non-latched behavior.

REFERENCE DESIGN

Application Schematic

Figure 12 shows the application schematic..

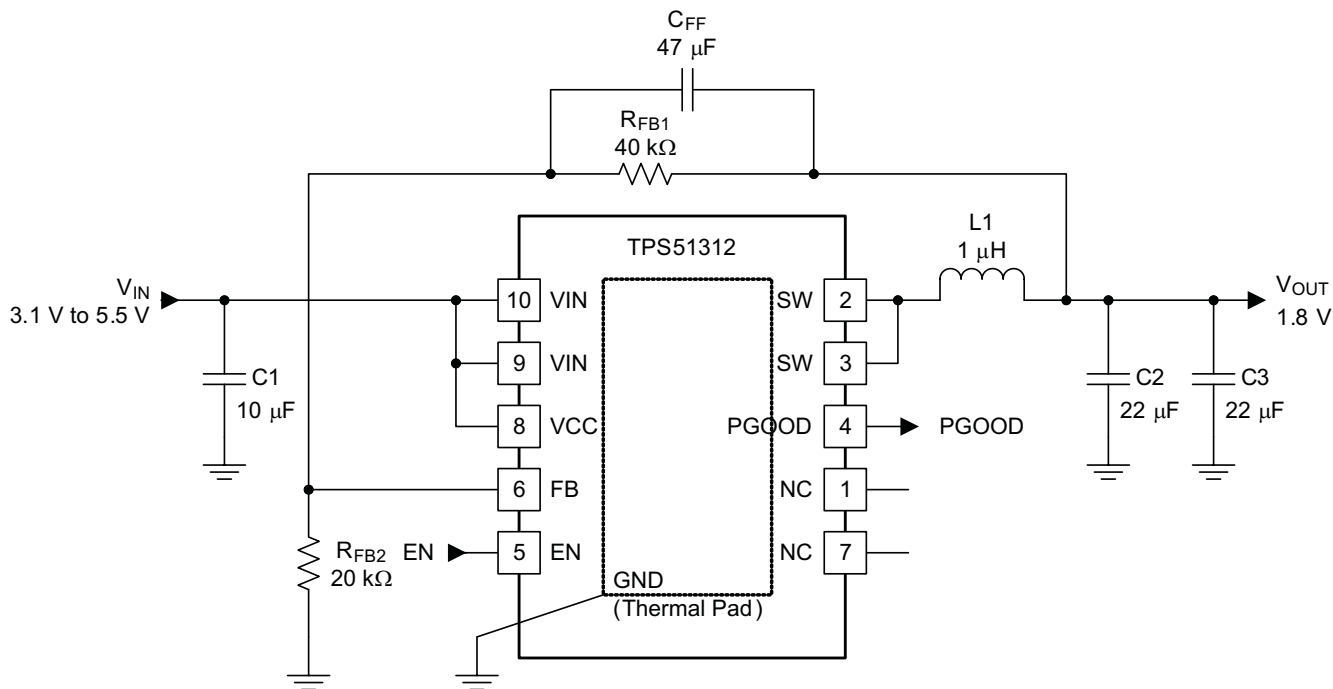

UDG-12145

Figure 12. Reference Design Schematic

Table 1. Reference Design List of Materials

FUNCTION	MANUFACTURER	PART NUMBER
Output Inductor	Vishay	IHLP-2020BZ-01
Ceramic Output Capacitors	Panasonic	ECJ2FB0J226M
	Murata	GRM21BR60J226ME39L

Design Procedure

Step One. Determine the specifications.

- $V_{OUT} = 1.8\text{ V}$
- $I_{CC(max)} = 3\text{ A}$
- $di/dt = 2.5\text{ A}/\mu\text{s}$

Step Two. Determine the system parameters.

The input voltage range and operating frequency are of primary interest. For example,

- $V_{IN} = V_{CC} = 5\text{ V}$
- $f_{SW} = 900\text{ kHz}$.

Step Three. Set the output voltage.

Use Equation 1 to determine the output voltage.

$$V_{OUT} = V_{REF} \times \left(\frac{R_{FB1} + R_{FB2}}{R_{FB2}} \right) \quad (1)$$

The output voltage is determined by VREF (0.6 V) and the resistor dividers (R_{FB1} and R_{FB2}). The output voltage is regulated to the FB pin. For the current reference design of 1.8 V, select 40 kΩ as the value for R_{FB1} and 20 kΩ as the value of R_{FB2} (see Figure 12). As a recommendation, choose a value of less 50 kΩ both resistors. Place a 47-pF, feedforward capacitor in parallel with R_{FB1} to help reduce the output voltage ripple during the transition from DCM to CCM.

Step Four. Determine inductor value and choose inductor.

Smaller inductance yields better transient performance but the consequence is higher ripple and lower efficiency. Higher values have the opposite characteristics. It is common practice to limit the ripple current to 25% to 50% of the maximum current. In this case, use 40%:

$$I_{p-p} = 3A \times 0.4 = 1.2A$$

where

- f_{SW} = 900 kHz
 - V_{IN} = 5 V
 - V_{OUT} = 1.8 V
- (2)

$$L = \frac{V \times dT}{I_{p-p}} = \left(\frac{V_{IN} - V_{OUT}}{I_{p-p}} \right) \times \left(\frac{V_{OUT}}{f_{SW} \times V_{IN}} \right) = 1\mu H \quad (3)$$

For this application, choose a 1-μH, 18.9-mΩ inductor from Vishay part number IHLP-2020BZ-01.

Step Five. Determine the output capacitance.

To determine C_{OUT} based on transient and stability requirement, first calculate the minimum output capacitance for a given transient.

Equation 4 and Equation 5 calculate the minimum output capacitance for meeting the transient requirement.

$$C_{OUT(min_under)} = \frac{L \times \Delta I_{LOAD(max)}^2 \times \left(\frac{V_{VOUT} \times t_{SW}}{V_{IN(min)}} + t_{MIN(off)} \right)}{2 \times \Delta V_{LOAD(insert)} \times \left(\left(\frac{V_{IN(min)} - V_{VOUT}}{V_{IN(min)}} \right) \times t_{SW} - t_{MIN(off)} \right) \times V_{VOUT}} \quad (4)$$

$$C_{OUT(min_over)} = \frac{L_{OUT} \times (\Delta I_{LOAD(max)})^2}{2 \times \Delta V_{LOAD(release)} \times V_{VOUT}} \quad (5)$$

Table 2. Choosing Output Inductors and Output Capacitors

TEMPERATURE	OUTPUT VOLTAGE V _{OUT} (V)	INDUCTANCE L _{OUT} (μH)	OUTPUT CAPACITORS		FAST FEEDFORWARD CAPACITOR C _{FF} (pF)
			NUMBER	VALUE (μF)	
-10°C ≤ T _A ≤ 85°C	1.5	1	1	22	47
	1.8	1	1		
	3.3	2.2	2		
-40°C ≤ T _A ≤ 85°C	1.5	1	2		
	1.8	1	2		
	3.3	2.2	3		

Step Six. Establishing the internal compensation loop.

The TPS51312 is designed with an internal compensation loop. The internal integrator zero location is approximately 60 kHz. During the time that the power stage double pole frequency contributed by the L_{OUT} and C_{OUT} is less than or equal to that of the zero location, the converter is stable with sufficient margin.

Step Seven. Select decoupling and peripheral components.

For TPS51312 peripheral capacitors use the following minimum value of ceramic capacitance, X5R or better temperature coefficient is recommended. Tighter tolerances and higher voltage ratings are always appropriate.

V_{CC} and V_{IN} decoupling $\geq 2 \times 10 \mu\text{F}$, 6.3 V

Pull up resistor on PGOOD = 100 k Ω

Layout Considerations

Good layout is essential for stable power supply operation. Follow these guidelines for an efficient PCB layout.

- Place V_{IN} , V_{CC} decoupling capacitors as close to the device as possible.
- Use wide traces for the VIN, SW and GND pins. These nodes carry high current and also serve as heat sinks.
- Place FB and voltage setting dividers as close to the device as possible.
- Place an R-C network from SW to GND to help to reduce the voltage spikes on the SW pin.

PACKAGING INFORMATION

Orderable Device	Status (1)	Package Type	Package Drawing	Pins	Package Qty	Eco Plan (2)	Lead finish/ Ball material (6)	MSL Peak Temp (3)	Op Temp (°C)	Device Marking (4/5)	Samples
TPS51312DRCR	ACTIVE	VSON	DRC	10	3000	RoHS & Green	NIPDAU	Level-2-260C-1 YEAR	-40 to 85	S51312	Samples
TPS51312DRCT	ACTIVE	VSON	DRC	10	250	RoHS & Green	NIPDAU	Level-2-260C-1 YEAR	-40 to 85	S51312	Samples

(1) The marketing status values are defined as follows:

ACTIVE: Product device recommended for new designs.

LIFEBUY: TI has announced that the device will be discontinued, and a lifetime-buy period is in effect.

NRND: Not recommended for new designs. Device is in production to support existing customers, but TI does not recommend using this part in a new design.

PREVIEW: Device has been announced but is not in production. Samples may or may not be available.

OBSOLETE: TI has discontinued the production of the device.

(2) **RoHS:** TI defines "RoHS" to mean semiconductor products that are compliant with the current EU RoHS requirements for all 10 RoHS substances, including the requirement that RoHS substance do not exceed 0.1% by weight in homogeneous materials. Where designed to be soldered at high temperatures, "RoHS" products are suitable for use in specified lead-free processes. TI may reference these types of products as "Pb-Free".

RoHS Exempt: TI defines "RoHS Exempt" to mean products that contain lead but are compliant with EU RoHS pursuant to a specific EU RoHS exemption.

Green: TI defines "Green" to mean the content of Chlorine (Cl) and Bromine (Br) based flame retardants meet JS709B low halogen requirements of <=1000ppm threshold. Antimony trioxide based flame retardants must also meet the <=1000ppm threshold requirement.

(3) MSL, Peak Temp. - The Moisture Sensitivity Level rating according to the JEDEC industry standard classifications, and peak solder temperature.

(4) There may be additional marking, which relates to the logo, the lot trace code information, or the environmental category on the device.

(5) Multiple Device Markings will be inside parentheses. Only one Device Marking contained in parentheses and separated by a "~" will appear on a device. If a line is indented then it is a continuation of the previous line and the two combined represent the entire Device Marking for that device.

(6) Lead finish/Ball material - Orderable Devices may have multiple material finish options. Finish options are separated by a vertical ruled line. Lead finish/Ball material values may wrap to two lines if the finish value exceeds the maximum column width.

Important Information and Disclaimer:The information provided on this page represents TI's knowledge and belief as of the date that it is provided. TI bases its knowledge and belief on information provided by third parties, and makes no representation or warranty as to the accuracy of such information. Efforts are underway to better integrate information from third parties. TI has taken and continues to take reasonable steps to provide representative and accurate information but may not have conducted destructive testing or chemical analysis on incoming materials and chemicals. TI and TI suppliers consider certain information to be proprietary, and thus CAS numbers and other limited information may not be available for release.

In no event shall TI's liability arising out of such information exceed the total purchase price of the TI part(s) at issue in this document sold by TI to Customer on an annual basis.

GENERIC PACKAGE VIEW

DRC 10

VSON - 1 mm max height

3 x 3, 0.5 mm pitch

PLASTIC SMALL OUTLINE - NO LEAD

This image is a representation of the package family, actual package may vary.
Refer to the product data sheet for package details.

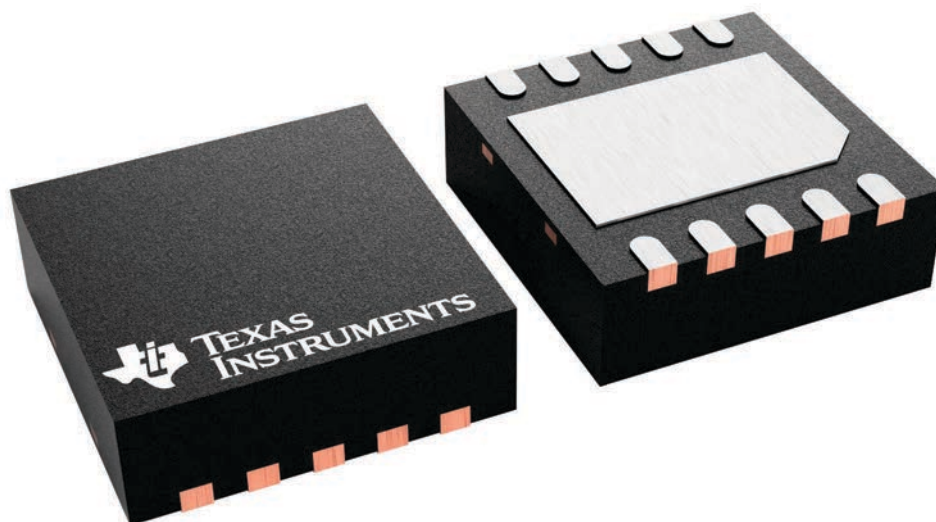

4226193/A

EXAMPLE BOARD LAYOUT

DRC0010J

VSON - 1 mm max height

PLASTIC SMALL OUTLINE - NO LEAD

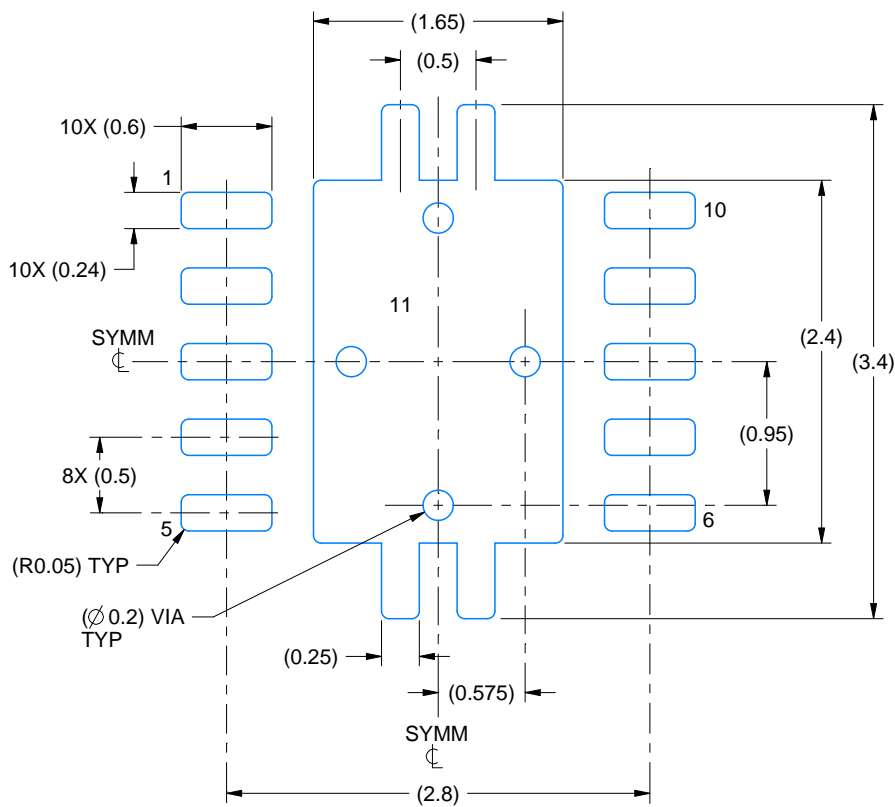

LAND PATTERN EXAMPLE
EXPOSED METAL SHOWN
SCALE:20X

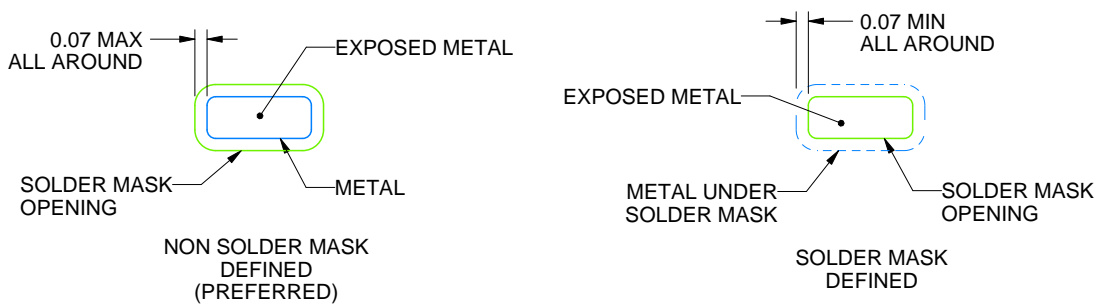

SOLDER MASK DETAILS

4218878/B 07/2018

NOTES: (continued)

4. This package is designed to be soldered to a thermal pad on the board. For more information, see Texas Instruments literature number SLUA271 (www.ti.com/lit/sluea271).
5. Vias are optional depending on application, refer to device data sheet. If any vias are implemented, refer to their locations shown on this view. It is recommended that vias under paste be filled, plugged or tented.

EXAMPLE STENCIL DESIGN

DRC0010J

VSON - 1 mm max height

PLASTIC SMALL OUTLINE - NO LEAD

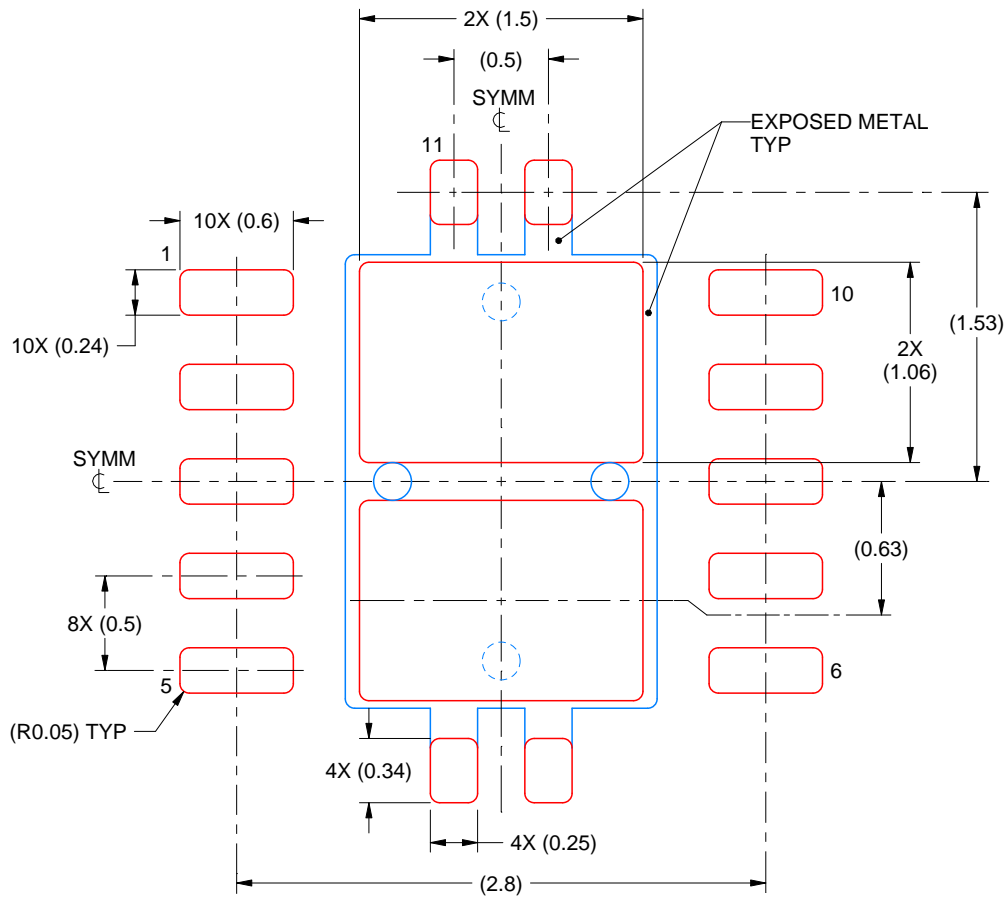

SOLDER PASTE EXAMPLE
BASED ON 0.125 mm THICK STENCIL

EXPOSED PAD 11:
80% PRINTED SOLDER COVERAGE BY AREA
SCALE:25X

4218878/B 07/2018

NOTES: (continued)

6. Laser cutting apertures with trapezoidal walls and rounded corners may offer better paste release. IPC-7525 may have alternate design recommendations.

重要声明和免责声明

TI 均以“原样”提供技术性及其可靠性数据（包括数据表）、设计资源（包括参考设计）、应用或其他设计建议、网络工具、安全信息和其他资源，不保证其中不含任何瑕疵，且不做任何明示或暗示的担保，包括但不限于对适销性、适合某特定用途或不侵犯任何第三方知识产权的暗示担保。

所述资源可供专业开发人员应用TI 产品进行设计使用。您将对以下行为独自承担全部责任：(1) 针对您的应用选择合适的TI 产品；(2) 设计、验证并测试您的应用；(3) 确保您的应用满足相应标准以及任何其他安全、安保或其他要求。所述资源如有变更，恕不另行通知。TI 对您使用所述资源的授权仅限于开发资源所涉及TI 产品的相关应用。除此之外不得复制或展示所述资源，也不提供其它TI 或任何第三方的知识产权授权许可。如因使用所述资源而产生任何索赔、赔偿、成本、损失及债务等，TI 对此概不负责，并且您须赔偿由此对TI 及其代表造成的损害。

TI 所提供产品均受TI 的销售条款 (<http://www.ti.com.cn/zh-cn/legal/termsofsale.html>) 以及 [ti.com.cn](http://www.ti.com.cn) 上或随附TI 产品提供的其他可适用条款的约束。TI 提供所述资源并不扩展或以其他方式更改TI 针对TI 产品所发布的可适用的担保范围或担保免责声明。

邮寄地址：上海市浦东新区世纪大道 1568 号中建大厦 32 楼，邮政编码：200122

Copyright © 2020 德州仪器半导体技术（上海）有限公司