

12-Bit, Sampling A/D Converter with I²C™ INTERFACE

FEATURES

- 50kHz SAMPLING RATE
- NO MISSING CODES
- 2.7V TO 5V OPERATION
- FOUR-WORD FILO
- A0, A1 ADDRESS PINS
- I²C INTERFACE SUPPORTS:
Standard, Fast, and High-Speed Modes
- MSOP-8 PACKAGE

DESCRIPTION

The ADS7823 is a single-supply, low-power, 12-bit data acquisition device that features a serial I²C interface. The Analog-to-Digital (A/D) converter features a sample-and-hold amplifier and internal, asynchronous clock. The combination of an I²C serial two-wire interface and micropower consumption makes the ADS7823 ideal for applications requiring the A/D converter to be close to the input source in remote locations and for applications requiring isolation. The ADS7823 is available in an MSOP-8 package.

APPLICATIONS

- VOLTAGE SUPPLY MONITORING
- ISOLATED DATA ACQUISITION
- TRANSDUCER INTERFACE
- BATTERY-OPERATED SYSTEMS
- REMOTE DATA ACQUISITION

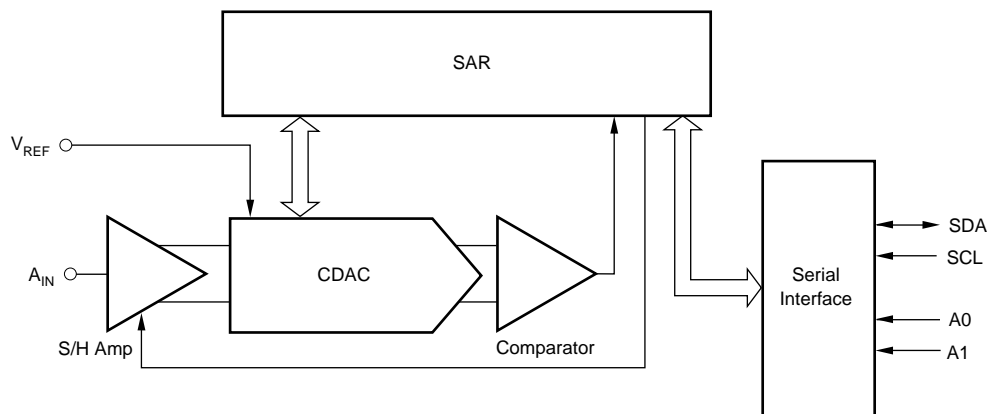

Please be aware that an important notice concerning availability, standard warranty, and use in critical applications of Texas Instruments semiconductor products and disclaimers thereto appears at the end of this data sheet.

All trademarks are the property of their respective owners.

ABSOLUTE MAXIMUM RATINGS⁽¹⁾

+V _{DD} to GND	-0.3V to +6V
Digital Input Voltage to GND	-0.3V to +V _{DD} + 0.3V
Analog Input Voltage to GND	-0.3V to +6.0V
Operating Temperature Range	-40°C to +85°C
Storage Temperature Range	-65°C to +150°C
Junction Temperature (T _J max)	+150°C
TSSOP Package	
Power Dissipation	(T _J max - T _A)/θ _{JA}
θ _{JA} Thermal Impedance	+240°C/W
Lead Temperature, Soldering	
Vapor Phase (60s)	+215°C
Infrared (15s)	+220°C

NOTE: (1) Stresses above those listed under "Absolute Maximum Ratings" may cause permanent damage to the device. Exposure to absolute maximum conditions for extended periods may affect device reliability.



ELECTROSTATIC DISCHARGE SENSITIVITY

This integrated circuit can be damaged by ESD. Texas Instruments recommends that all integrated circuits be handled with appropriate precautions. Failure to observe proper handling and installation procedures can cause damage.

ESD damage can range from subtle performance degradation to complete device failure. Precision integrated circuits may be more susceptible to damage because very small parametric changes could cause the device not to meet its published specifications.

PACKAGE/ORDERING INFORMATION

PRODUCT	MAXIMUM INTEGRAL LINEARITY ERROR (LSB)	SPECIFIED TEMPERATURE RANGE	PACKAGE-LEAD	PACKAGE DESIGNATOR ⁽¹⁾	PACKAGE MARKING	ORDERING NUMBER	TRANSPORT MEDIA, QUANTITY
ADS7823E	±2	-40°C to +85°C	MSOP-8	DGK	B23	ADS7823E/250	Tape and Reel, 250
"	"	"	"	"	"	ADS7823E/2K5	Tape and Reel, 2500
ADS7823EB	±1	-40°C to +85°C	MSOP-8	DGK	B23	ADS7823EB/250	Tape and Reel, 250
"	"	"	"	"	"	ADS7823EB/2K5	Tape and Reel, 2500

NOTE: (1) For the most current specifications and package information, refer to our web site at www.ti.com.

ELECTRICAL CHARACTERISTICS: +2.7V

At T_A = -40°C to +85°C, +V_{DD} = +2.7V, V_{REF} = +2.5V, SCL Clock Frequency = 3.4MHz (High Speed Mode) unless otherwise noted.

PARAMETER	CONDITIONS	ADS7823E			ADS7823EB			UNITS
		MIN	TYP	MAX	MIN	TYP	MAX	
RESOLUTION				12			*	Bits
ANALOG INPUT								
Full-Scale Input Range		0		V _{REF}	*		*	V
Input Capacitance			25			*		pF
Input Leakage Current			±1			*		µA
SYSTEM PERFORMANCE								
No Missing Codes		12			*			Bits
Integral Linearity Error			±1.0	±2		±0.5	±1	LSB ⁽¹⁾
Differential Linearity Error			-0.5, +1.0	-1.0, +3.0		±0.5	*	LSB
Offset Error			±1.0	±4		±0.75	±3	LSB
Gain Error			±1.0	±4		±0.75	±3	LSB
Noise			33			*		µVrms
Power Supply Rejection			82			*		dB
SAMPLING DYNAMICS								
Throughput Frequency	High Speed Mode: SCL = 3.4MHz Fast Mode: SCL = 400kHz Standard Mode, SCL = 100kHz			50 8 2			*	kHz
Conversion Time			8			*		µs
AC ACCURACY								
Total Harmonic Distortion	V _{IN} = 2.5V _{pp} at 10kHz		-82			*		dB ⁽²⁾
Signal-to-Ratio	V _{IN} = 2.5V _{pp} at 10kHz		72			*		dB
Signal-to-(Noise+Distortion) Ratio	V _{IN} = 2.5V _{pp} at 10kHz		71			*		dB
Spurious Free Dynamic Range	V _{IN} = 2.5V _{pp} at 10kHz		86			*		dB
VOLTAGE REFERENCE INPUT								
Range		0.05		V _{DD}	*		*	V
Resistance	All Modes		1.0			*		GΩ
Current Drain	At Code 800H, HS Mode: SCL = 3.4MHz		9.0			*		µA

ELECTRICAL CHARACTERISTICS: +2.7V (Cont.)

At $T_A = -40^{\circ}\text{C}$ to $+85^{\circ}\text{C}$, $+V_{DD} = +2.7\text{V}$, $V_{REF} = +2.5\text{V}$, SCL Clock Frequency = 3.4MHz (High Speed Mode) unless otherwise noted.

PARAMETER	CONDITIONS	ADS7823E			ADS7823EB			UNITS
		MIN	TYP	MAX	MIN	TYP	MAX	
DIGITAL INPUT/OUTPUT Logic Family Logic Levels: V_{IH} V_{IL} V_{OL} Input Leakage: I_{IH} I_{IL} Data Format	At min 3mA Sink Current $V_{IH} = +V_{DD} + 0.5$ $V_{IL} = -0.3$	$+V_{DD} \cdot 0.7$ -0.3	CMOS	$+V_{DD} + 0.5$ $+V_{DD} \cdot 0.3$ 0.4 10	*	*	*	V V V μA μA
ADS7823 HARDWARE ADDRESS			10010			*		Binary
POWER SUPPLY REQUIREMENTS Power Supply Voltage, $+V_{DD}$ Quiescent Current Power Dissipation Powerdown Mode w/Wrong Address Selected Full Powerdown	Specified Performance High Speed Mode: SCL = 3.4MHz Fast Mode: SCL = 400kHz Standard Mode: SCL = 100kHz High Speed Mode: SCL = 3.4MHz Fast Mode: SCL = 400kHz Standard Mode: SCL = 100kHz High Speed Mode: SCL = 3.4MHz Fast Mode: SCL = 400kHz Standard Mode: SCL = 100kHz SCL Pulled HIGH, SDA Pulled HIGH	2.7		3.6 250 137 109 680 370 290 60 23 5.4 2			*	V μA μA μA μW μW μW μA μA μA nA
TEMPERATURE RANGE Specified Performance		-40		85	*		*	$^{\circ}\text{C}$

* Specifications same as ADS7823E.

NOTES: (1) LSB means Least Significant Bit. With V_{REF} equal to 2.5V, 1LSB is 610 μV . (2) THD measured out to the 9th-harmonic.

ELECTRICAL CHARACTERISTICS: +5V

At $T_A = -40^{\circ}\text{C}$ to $+85^{\circ}\text{C}$, $+V_{DD} = +5.0\text{V}$, $V_{REF} = +5.0\text{V}$, SCL Clock Frequency = 3.4MHz (High Speed Mode) unless otherwise noted.

PARAMETER	CONDITIONS	ADS7823E			ADS7823EB			UNITS
		MIN	TYP	MAX	MIN	TYP	MAX	
RESOLUTION				12			*	Bits
ANALOG INPUT Full-Scale Input Range Input Capacitance Input Leakage Current		0	25 ± 1	V_{REF}	*	*	*	V pF μA
SYSTEM PERFORMANCE No Missing Codes Integral Linearity Error Differential Linearity Error Offset Error Gain Error Noise Power Supply Rejection		12	± 1.0 -0.5, +1.0 ± 1.0 ± 1.0 33 82	± 2 -1, +3 ± 4 ± 4	*	± 0.5 ± 0.75 ± 0.75 *	± 1 * ± 3 ± 3 *	Bits LSB ⁽¹⁾ LSB LSB LSB μV_{rms} dB
SAMPLING DYNAMICS Throughput Frequency Conversion Time	High Speed Mode: SCL = 3.4MHz Fast Mode: SCL = 400kHz Standard Mode: SCL = 100kHz		8	50 8 2			*	kHz kHz kHz μs
AC ACCURACY Total Harmonic Distortion Signal-to-Ratio Signal-to-(Noise+Distortion) Ratio Spurious Free Dynamic Range	$V_{IN} = 2.5V_{PP}$ at 10kHz $V_{IN} = 2.5V_{PP}$ at 10kHz $V_{IN} = 2.5V_{PP}$ at 10kHz $V_{IN} = 2.5V_{PP}$ at 10kHz		-82 72 71 86			*	*	dB ⁽²⁾ dB dB dB
VOLTAGE REFERENCE INPUT Range Resistance Current Drain	All Modes At Code 800H, HS Mode: SCL = 3.4MHz	0.05	1.0 20	V_{DD}	*	*	*	V G Ω μA

ELECTRICAL CHARACTERISTICS: +5V (Cont.)

At $T_A = -40^{\circ}\text{C}$ to $+85^{\circ}\text{C}$, $+V_{DD} = +5.0\text{V}$, $V_{REF} = +5.0\text{V}$, SCL Clock Frequency = 3.4MHz (High Speed Mode) unless otherwise noted.

PARAMETER	CONDITIONS	ADS7823E			ADS7823EB			UNITS
		MIN	TYP	MAX	MIN	TYP	MAX	
DIGITAL INPUT/OUTPUT								
Logic Family		CMOS				*		V
Logic Levels: V_{IH}		$+V_{DD} \bullet 0.7$		$+V_{DD} + 0.5$	*		*	V
V_{IL}		-0.3		$+V_{DD} \bullet 0.3$	*		*	V
V_{OL}				0.4			*	V
Input Leakage: I_{IH}	At min 3mA Sink Current			10			*	μA
I_{IL}	$V_{IH} = +V_{DD} + 0.5$ $V_{IL} = -0.3$	-10			*		*	μA
Data Format			Straight Binary			*		
ADS7823 HARDWARE ADDRESS			10010			*		Binary
POWER SUPPLY REQUIREMENTS								
Power Supply Voltage, $+V_{DD}$	Specified Performance	4.75	5	5.25	*		*	V
Quiescent Current	High Speed Mode: SCL= 3.4MHz		0.72	1.0		*	*	mA
	Fast Mode: SCL= 400kHz		380			*		μA
	Standard Mode, SCL=100kHz		240			*		μA
Power Dissipation	High Speed Mode: SCL= 3.4MHz		3.6	5.0		*	*	mW
	Fast Mode: SCL= 400kHz		1.9			*		mW
	Standard Mode, SCL=100kHz		1.2			*		mW
Powerdown Mode	High Speed Mode: SCL= 3.4MHz		346			*		μA
w/Wrong Address Selected	Fast Mode: SCL= 400kHz		136			*		μA
	Standard Mode, SCL=100kHz		34			*		μA
Full Powerdown	SCL Pulled HIGH, SDA Pulled HIGH		3	3000		*	*	nA
TEMPERATURE RANGE								
Specified Performance		-40		85	*		*	$^{\circ}\text{C}$

* Specifications same as ADS7823E.

NOTES: (1) LSB means Least Significant Bit. With V_{REF} equal to 2.5V, 1LSB is 610 μV . (2) THD measured out to the 9th-harmonic.

PIN CONFIGURATION

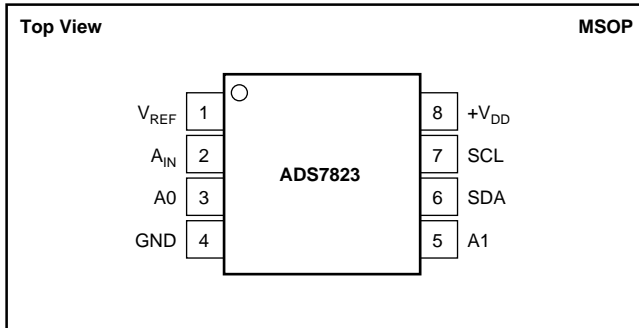

PIN DESCRIPTIONS

PIN	NAME	DESCRIPTION
1	V_{REF}	Reference Input, 2.5V Nominal
2	A_{IN}	Analog Input.
3	A0	Slave Address Bit 0
4	GND	Ground
5	A1	Slave Address Bit 1
6	SDA	Serial Data
7	SCL	Serial Clock
8	$+V_{DD}$	Power Supply, 3.3V Nominal

TIMING DIAGRAM

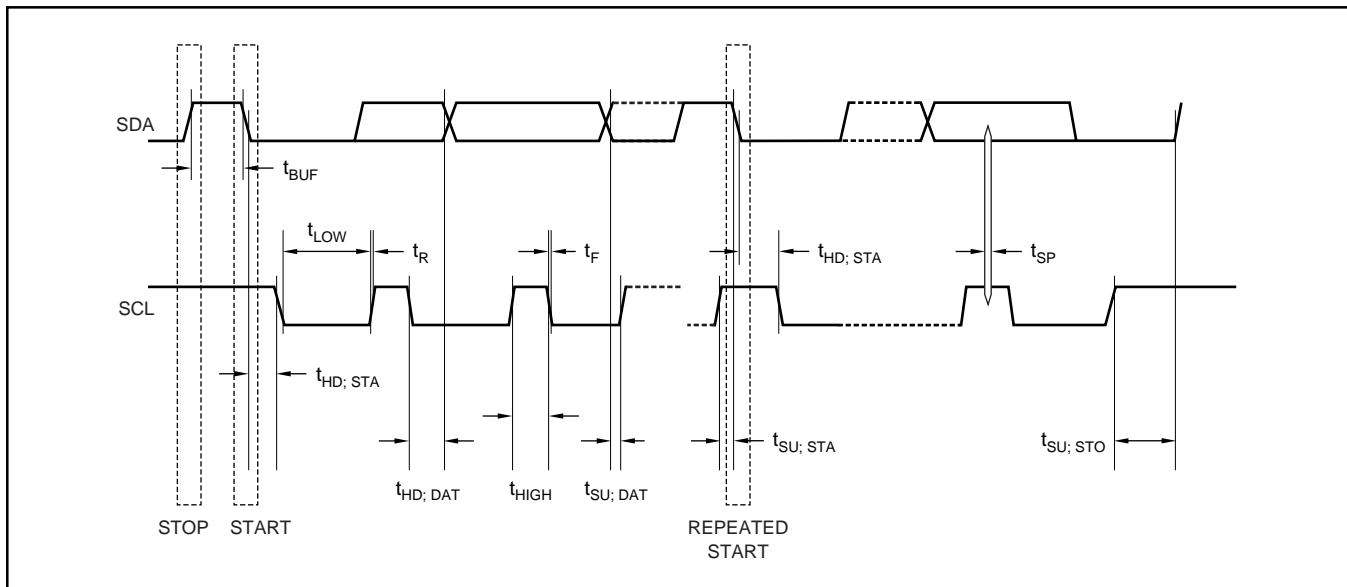

TIMING CHARACTERISTICS⁽¹⁾

At $T_A = -40^\circ\text{C}$ to $+85^\circ\text{C}$, $+V_{DD} = +2.7\text{V}$, unless otherwise noted.

PARAMETER	SYMBOL	CONDITIONS	MIN	MAX	UNITS
SCL Clock Frequency	f_{SCL}	Standard Mode Fast Mode High-Speed Mode, $C_B = 100\text{pF}$ max High-Speed Mode, $C_B = 400\text{pF}$ max		100 400 3.4 1.7	kHz kHz MHz MHz
Bus Free Time Between a STOP and START Condition	t_{BUF}	Standard Mode Fast Mode	4.7 1.3		μs μs
Hold Time (Repeated) START Condition	$t_{\text{HD:STA}}$	Standard Mode Fast Mode High-Speed Mode	4.0 600 160		μs ns ns
LOW Period of the SCL Clock	t_{LOW}	Standard Mode Fast Mode High-Speed Mode, $C_B = 100\text{pF}$ max ⁽²⁾ High-Speed Mode, $C_B = 400\text{pF}$ max ⁽²⁾	4.7 1.3 160 320		μs μs ns ns
HIGH Period of the SCL Clock	t_{HIGH}	Standard Mode Fast Mode High-Speed Mode, $C_B = 100\text{pF}$ max ⁽²⁾ High-Speed Mode, $C_B = 400\text{pF}$ max ⁽²⁾	4.0 600 60 120		μs ns ns ns
Setup Time for a Repeated START Condition	$t_{\text{SU:STA}}$	Standard Mode Fast Mode High-Speed Mode	4.7 600 160		μs ns ns
Data Setup Time	$t_{\text{SU:DAT}}$	Standard Mode Fast Mode High-Speed Mode	250 100 10		ns ns ns
Data Hold Time	$t_{\text{HD:DAT}}$	Standard Mode Fast Mode High-Speed Mode, $C_B = 100\text{pF}$ max ⁽²⁾ High-Speed Mode, $C_B = 400\text{pF}$ max ⁽²⁾	0 0 0 ⁽³⁾ 0 ⁽³⁾	3.45 0.9 70 150	μs μs ns ns
Rise Time of SCL Signal	t_{RCL}	Standard Mode Fast Mode High-Speed Mode, $C_B = 100\text{pF}$ max ⁽²⁾ High-Speed Mode, $C_B = 400\text{pF}$ max ⁽²⁾	$20 + 0.1C_B$ 10 10 20	1000 300 40 80	ns ns ns ns
Rise Time of SCL Signal After a Repeated START Condition and After an Acknowledge Bit	t_{RCL1}	Standard Mode Fast Mode High-Speed Mode, $C_B = 100\text{pF}$ max ⁽²⁾ High-Speed Mode, $C_B = 400\text{pF}$ max ⁽²⁾	$20 + 0.1C_B$ 10 10 20	1000 300 80 160	ns ns ns ns
Fall Time of SCL Signal	t_{FCL}	Standard Mode Fast Mode High-Speed Mode, $C_B = 100\text{pF}$ max ⁽²⁾ High-Speed Mode, $C_B = 400\text{pF}$ max ⁽²⁾	$20 + 0.1C_B$ 10 10 20	300 300 40 80	ns ns ns ns
Rise Time of SDA Signal	t_{RDA}	Standard Mode Fast Mode High-Speed Mode, $C_B = 100\text{pF}$ max ⁽²⁾ High-Speed Mode, $C_B = 400\text{pF}$ max ⁽²⁾	$20 + 0.1C_B$ 10 10 20	1000 300 80 160	ns ns ns ns
Fall Time of SDA Signal	t_{FDA}	Standard Mode Fast Mode High-Speed Mode, $C_B = 100\text{pF}$ max ⁽²⁾ High-Speed Mode, $C_B = 400\text{pF}$ max ⁽²⁾	$20 + 0.1C_B$ 10 10 20	300 300 80 160	ns ns ns ns
Setup Time for STOP Condition	$t_{\text{SU:STO}}$	Standard Mode Fast Mode High-Speed Mode	4.0 600 160		μs ns ns
Capacitive Load for SDA and SCL Line	C_B			400	pF
Pulse Width of Spike Suppressed	t_{SP}	Fast Mode High-Speed Mode		50 10	ns ns
Noise Margin at the HIGH Level for Each Connected Device (Including Hysteresis)	V_{NH}	Standard Mode Fast Mode High-Speed Mode	$0.2V_{\text{DD}}$		V
Noise Margin at the LOW Level for Each Connected Device (Including Hysteresis)	V_{NL}	Standard Mode Fast Mode High-Speed Mode	$0.1V_{\text{DD}}$		V

NOTES: (1) All values referred to V_{IHMIN} and V_{ILMAX} levels. (2) For bus line loads C_B between 100pF and 400pF the timing parameters must be linearly interpolated. (3) A device must internally provide a data hold time to bridge the undefined part between V_{IH} and V_{IL} of the falling edge of the SCLH signal. An input circuit with a threshold as low as possible for the falling edge of the SCLH signal minimizes this hold time.

TYPICAL CHARACTERISTICS

At $T_A = +25^\circ\text{C}$, $+V_{DD} = +2.7\text{V}$, $V_{REF} = \text{External } +2.5\text{V}$, $f_{\text{SAMPLE}} = 50\text{kHz}$, unless otherwise noted.

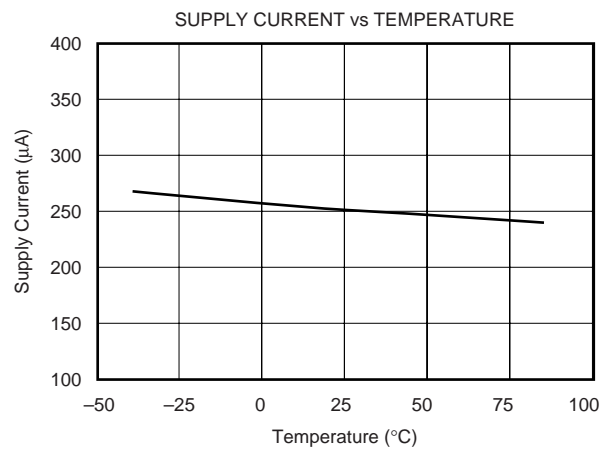
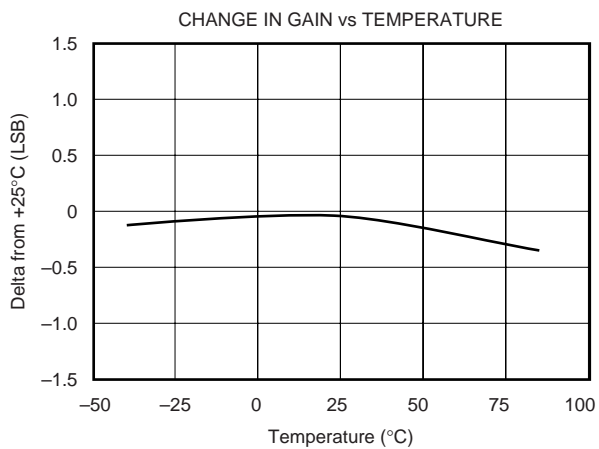
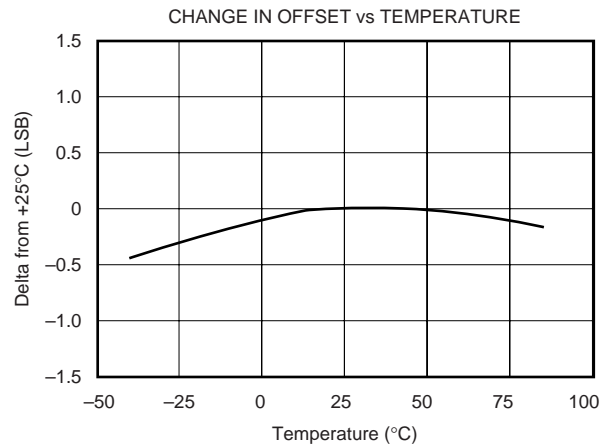
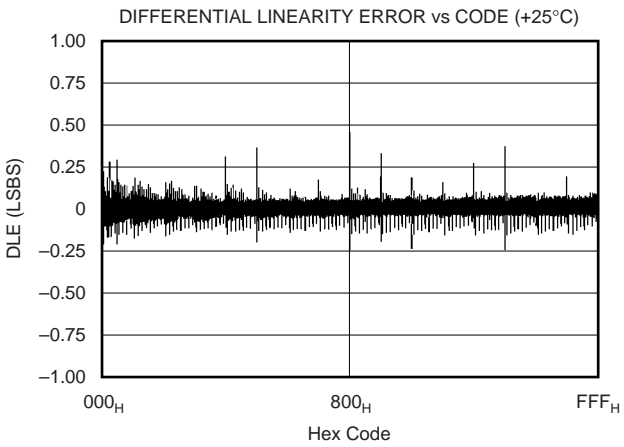
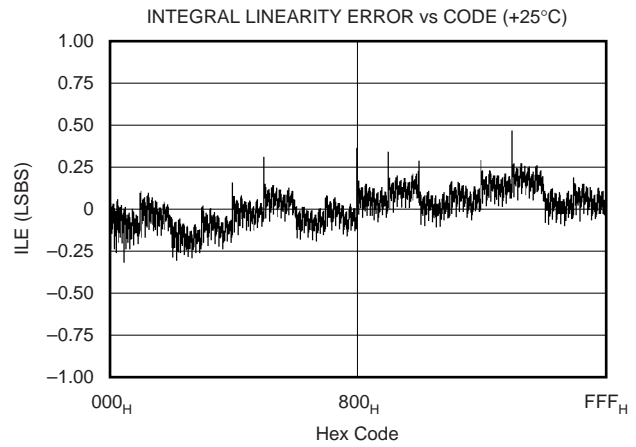
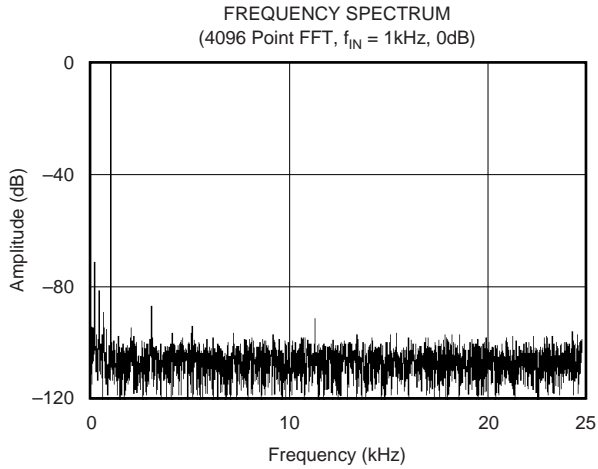

TYPICAL CHARACTERISTICS (Cont.)

At $T_A = +25^\circ\text{C}$, $+V_{DD} = +2.7\text{V}$, $V_{REF} = \text{External } +2.5\text{V}$, $f_{\text{SAMPLE}} = 50\text{kHz}$, unless otherwise noted.

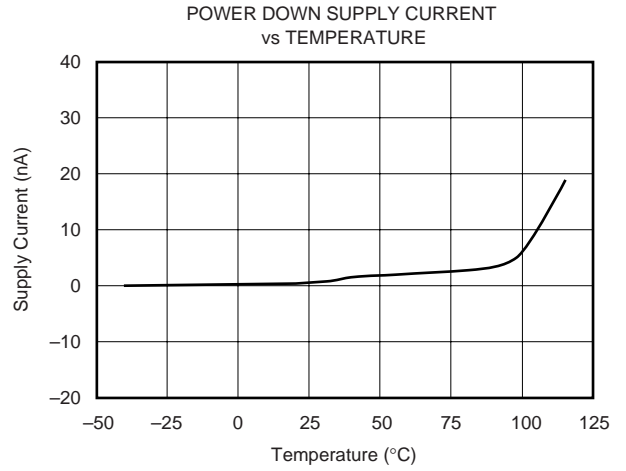
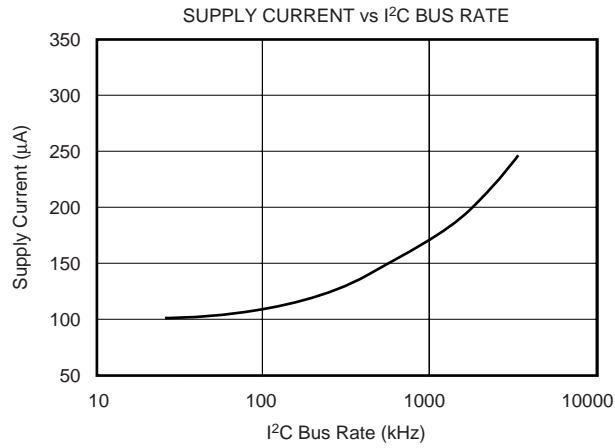

THEORY OF OPERATION

The ADS7823 is a classic Successive Approximation Register (SAR) A/D converter. The architecture is based on capacitive redistribution which inherently includes a sample-and-hold function. The converter is fabricated on a 0.6 μ m CMOS process.

The ADS7823 core is controlled by an internally-generated free-running clock. When the ADS7823 is not performing conversions or being addressed, it keeps the A/D converter core powered off, and the internal clock does not operate.

The ADS7823 has an internal 4-word first-in last-out buffer (FILO) that stores the results of up to four conversions while they are waiting to be read out over the I²C bus.

The simplified diagram of input and output for the ADS7823 is shown in Figure 1.

ANALOG INPUT

When the converter enters the hold mode, the voltage on the A_{IN} pin is captured on the internal capacitor array. The input current on the analog inputs depends on the conversion rate of the device. During the sample period, the source must charge the internal sampling capacitor (typically 25pF). After the capacitor has been fully charged, there is no further input current. The amount of charge transfer from the analog source to the converter is a function of conversion rate.

REFERENCE INPUT

The external reference sets the analog input range. The ADS7823 will operate with a reference in the range of 50mV to V_{DD}. There are several important implications of this.

As the reference voltage is reduced, the analog voltage weight of each digital output code is reduced. This is often referred to as the LSB (least significant bit) size and is equal to the reference voltage divided by 4096. This means that any offset or gain error inherent in the A/D converter will appear to increase, in terms of LSB size, as the reference voltage is reduced.

The noise inherent in the converter will also appear to increase with lower LSB size. With a 2.5V reference, the internal noise of the converter typically contributes only 0.32LSB peak-to-peak of potential error to the output code. When the external reference is 50mV, the potential error contribution from the internal noise will be 50 times larger—16LSBs. The errors due to the internal noise are Gaussian in nature and can be reduced by averaging consecutive conversion results.

DIGITAL INTERFACE

The ADS7823 supports the I²C serial bus and data transmission protocol, in all three defined modes: standard, fast, and high-speed. A device that sends data onto the bus is defined as a transmitter, and a device receiving data as a receiver.

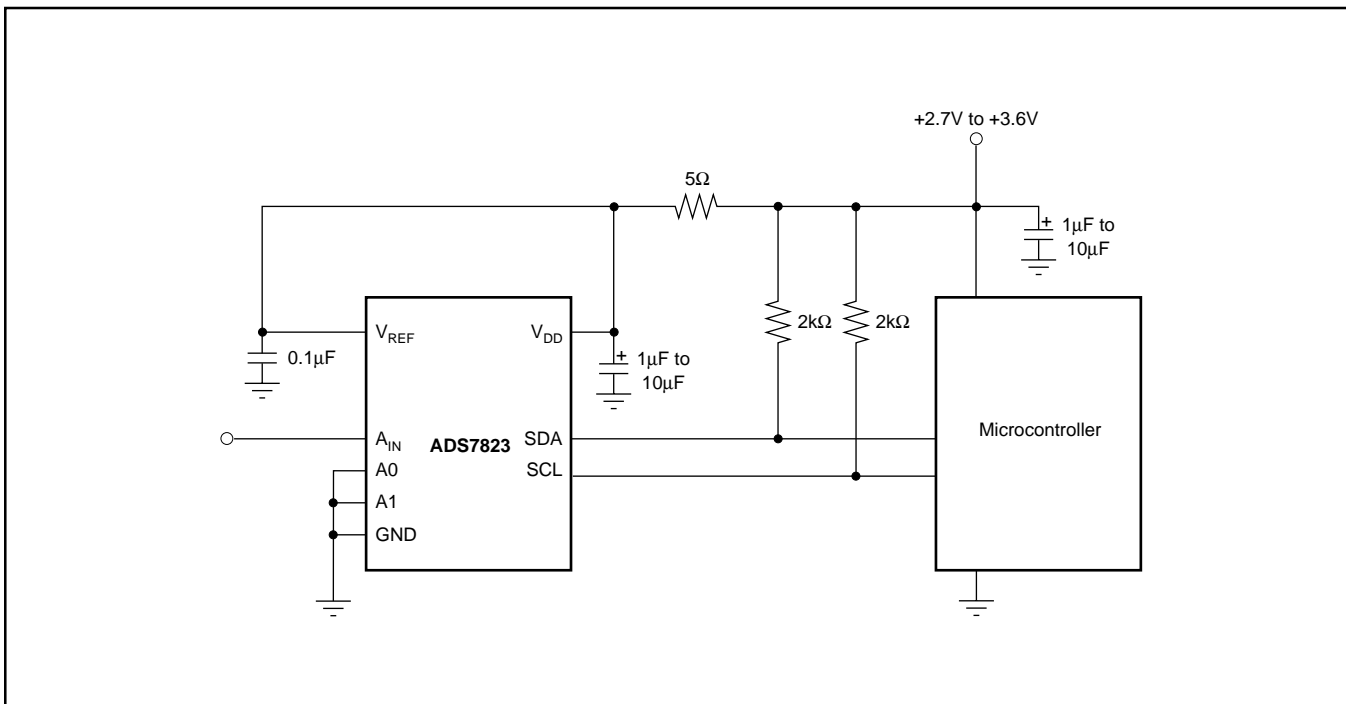

FIGURE 1. Simplified I/O of the ADS7823.

The device that controls the message is called a “master.” The devices that are controlled by the master are “slaves.” The bus must be controlled by a master device that generates the serial clock (SCL), controls the bus access, and generates the START and STOP conditions. The ADS7823 operates as a slave on the I²C bus. Connections to the bus are made via the open-drain I/O lines SDA and SCL.

The following bus protocol has been defined (as shown in Figure 2):

- Data transfer may be initiated only when the bus is not busy.
- During data transfer, the data line must remain stable whenever the clock line is HIGH. Changes in the data line while the clock line is HIGH will be interpreted as control signals.

Accordingly, the following bus conditions have been defined:

Bus Not Busy: Both data and clock lines remain HIGH.

Start Data Transfer: A change in the state of the data line, from HIGH to LOW, while the clock is HIGH, defines a START condition.

Stop Data Transfer: A change in the state of the data line, from LOW to HIGH, while the clock line is HIGH, defines the STOP condition.

Data Valid: The state of the data line represents valid data, when, after a START condition, the data line is stable for the duration of the HIGH period of the clock signal. There is one clock pulse per bit of data.

Each data transfer is initiated with a START condition and terminated with a STOP condition. The number of data bytes transferred between START and STOP conditions is not limited and is determined by the master device. The information is transferred byte-wise and each receiver acknowledges with a ninth bit.

Within the I²C bus specifications a standard mode (100kHz clock rate), a fast mode (400kHz clock rate), and a high-speed mode (3.4MHz clock rate) are defined. The ADS7823 works in all three modes.

Acknowledge: Each receiving device, when addressed, is obliged to generate an acknowledge after the reception of each byte. The master device must generate an extra clock pulse that is associated with this acknowledge bit.

A device that acknowledges must pull down the SDA line during the acknowledge clock pulse in such a way that the SDA line is stable LOW during the HIGH period of the acknowledge clock pulse. Of course, setup and hold times must be taken into account. A master must signal an end of data to the slave by not generating an acknowledge bit on the last byte that has been clocked out of the slave. In this case, the slave must leave the data line HIGH to enable the master to generate the STOP condition.

Figure 2 details how data transfer is accomplished on the I²C bus. Depending upon the state of the R/W bit, two types of data transfer are possible:

- 1. Data transfer from a master transmitter to a slave receiver.** The first byte transmitted by the master is the slave address. Next follows a number of data bytes. The slave returns an acknowledge bit after the slave address and each received byte.
- 2. Data transfer from a slave transmitter to a master receiver.** The first byte, the slave address, is transmitted by the master. The slave then returns an acknowledge bit. Next, a number of data bytes are transmitted by the slave to the master. The master returns an acknowledge bit after all received bytes other than the last byte. At the end of the last received byte, a not-acknowledge is returned.

The master device generates all of the serial clock pulses and the START and STOP conditions. A transfer is ended with a STOP condition or a repeated START condition. Since a repeated START condition is also the beginning of the next serial transfer, the bus will not be released.

The ADS7823 may operate in the following two modes:

- **Slave Receiver Mode:** Serial data and clock are received through SDA and SCL. After each byte is received, an acknowledge bit is transmitted. START and STOP conditions are recognized as the beginning and end of a serial transfer. Address recognition is performed by hardware after reception of the slave address and direction bit.
- **Slave Transmitter Mode:** The first byte (the slave address) is received and handled as in the slave receiver mode. However, in this mode the direction bit will indicate that the transfer direction is reversed. Serial data is transmitted on SDA by the ADS7823 while the serial clock is input on SCL. START and STOP conditions are recognized as the beginning and end of a serial transfer.

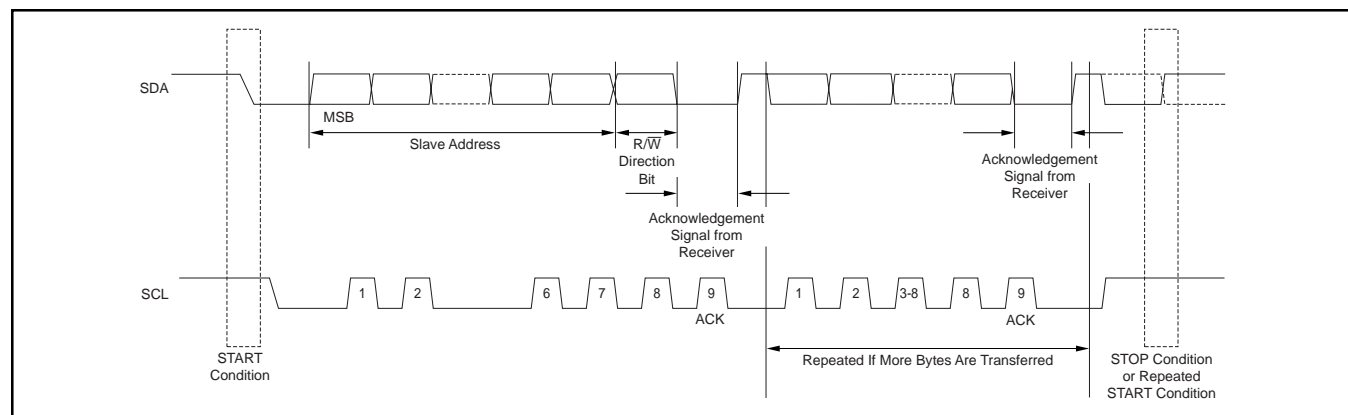

FIGURE 2. Basic Operation of the ADS7823.

ADDRESS BYTE

MSB	6	5	4	3	2	1	LSB
1	0	0	1	0	A1	A0	R/ \bar{W}

The address byte is the first byte received following the START condition from the master device. The first five bits (MSBs) of the slave address are factory pre-set to 10010. The next two bits of the address byte are the device select bits, A1 and A0. Input pins (A1-A0) on the ADS7823 determine these two bits of the device address for a particular ADS7823. A maximum of four devices with the same pre-set code can therefore be connected on the same bus at one time.

The A1-A0 Address Inputs can be connected to V_{DD} or digital ground. The device address is set by the state of these pins upon power-up of the ADS7823.

The last bit of the address byte (R/\bar{W}) defines the operation to be performed. When set to a "1" a read operation is selected; when set to a "0" a write operation is selected. Following the START condition the ADS7823 monitors the SDA bus, checking the device type identifier being transmitted. Upon receiving the 10010 code, the appropriate device select bits, and the R/\bar{W} bit, the slave device outputs an acknowledge signal on the SDA line.

COMMAND BYTE

MSB	6	5	4	3	2	1	LSB
0	0	0	X	X	X	X	X

The ADS7823 operating mode is determined by a command byte.

The ADS7823 command byte simply consists of three zeros in the most significant bits, while the remaining 5 bits are don't cares.

INITIATING CONVERSION

Provided the master has write-addressed it, the ADS7823 turns on the A/D converter section and begins conversions when it receives bit 5 of the command byte shown in the Command Byte. If the command byte is correct, the ADS7823 will return an ACK condition.

The converter will ignore any wrong command byte (that is, setting any of the top three MSBs to 1), remain in the A/D converter power-down mode, and reset the internal 4-word stack.

The ADS7823 will ignore a second valid command byte if two valid commands are issued consecutively. The ADS7823 will respond with a not-acknowledge, and will go to the A/D converter power-down mode after the responded not-acknowledge.

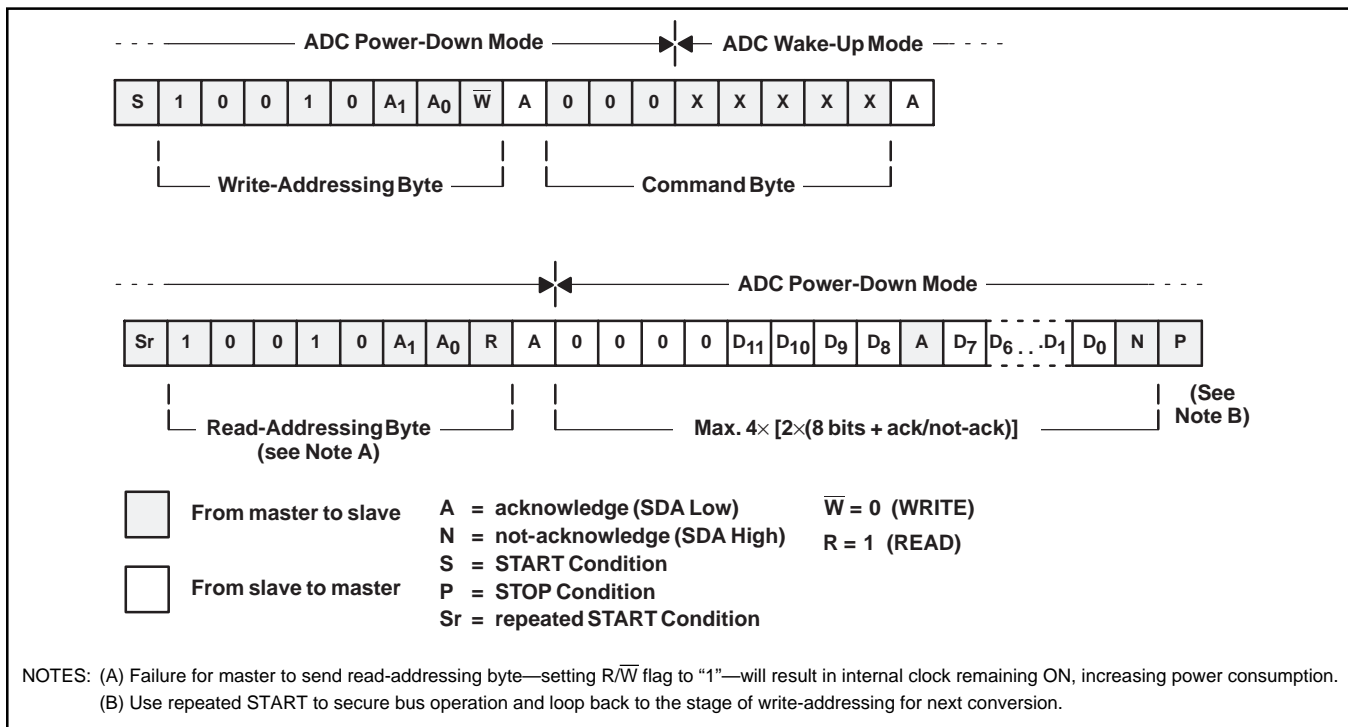

FIGURE 3. Typical Read Sequence in F/S Mode.

READING DATA

Data can be read from the ADS7823 by read-addressing the part (LSB of address byte set to 1) and receiving the transmitted bytes. Converted data can only be read from the ADS7823 once a conversion has been initiated as described in the preceding section.

Each 12-bit data word is returned in two bytes, as shown below, where D11 is the MSB of the data word, and D0 is the LSB. Byte 0 is sent first, followed by Byte 1.

	MSB	6	5	4	3	2	1	LSB
BYTE0	0	0	0	0	D11	D10	D9	D8
BYTE1	D7	D6	D5	D4	D3	D2	D1	D0

READING IN F/S MODE

In Fast and Standard (F/S) modes, the A/D converter has time to make four complete conversions between the reception of bit 5 of the command byte and the complete reception of the read address, even when operating in Fast mode.

Because the ADS7823 can perform these conversions much faster than they can be transmitted in F/S mode, data is stored in a four-level FILO. During the read operation, the A/D converter is powered down and the contents of the stack are read out one by one in the correct order.

A typical transfer sequence for reading four words of data in F/S mode (see Figure 3). Note that the master sends a not-

acknowledge after the fourth data word has been read. This tells the ADS7823 that no further reads will be performed. No more than four data words should be read at a time; further reads will return undefined data.

Although a STOP condition is shown at the end of the figure, it is permissible to issue a repeated START; this will have the same effect.

READING IN HS MODE

High Speed (HS) mode is fast enough that codes can be read out one at a time, without employing the FILO. In HS mode there is not enough time for a single conversion to complete between the reception of command bit 5 and the read address byte, so the ADS7823 stretches the clock after the command byte has been fully received, holding it LOW until the conversion is complete.

A typical read sequence for HS mode is shown in Figure 4. Included in the read sequence is the shift from F/S to HS modes. It may be desirable to remain in HS mode after reading a code; to do this, issue a repeated START instead of a STOP at the end of the read sequence, since a STOP causes the part to return to F/S mode.

It is very important not to read more than one code at a time from the ADS7823 during HS mode. If codes are read out more than one at a time, as in F/S mode, the results for all codes (except the first) are undefined, and the data stream will be corrupt.

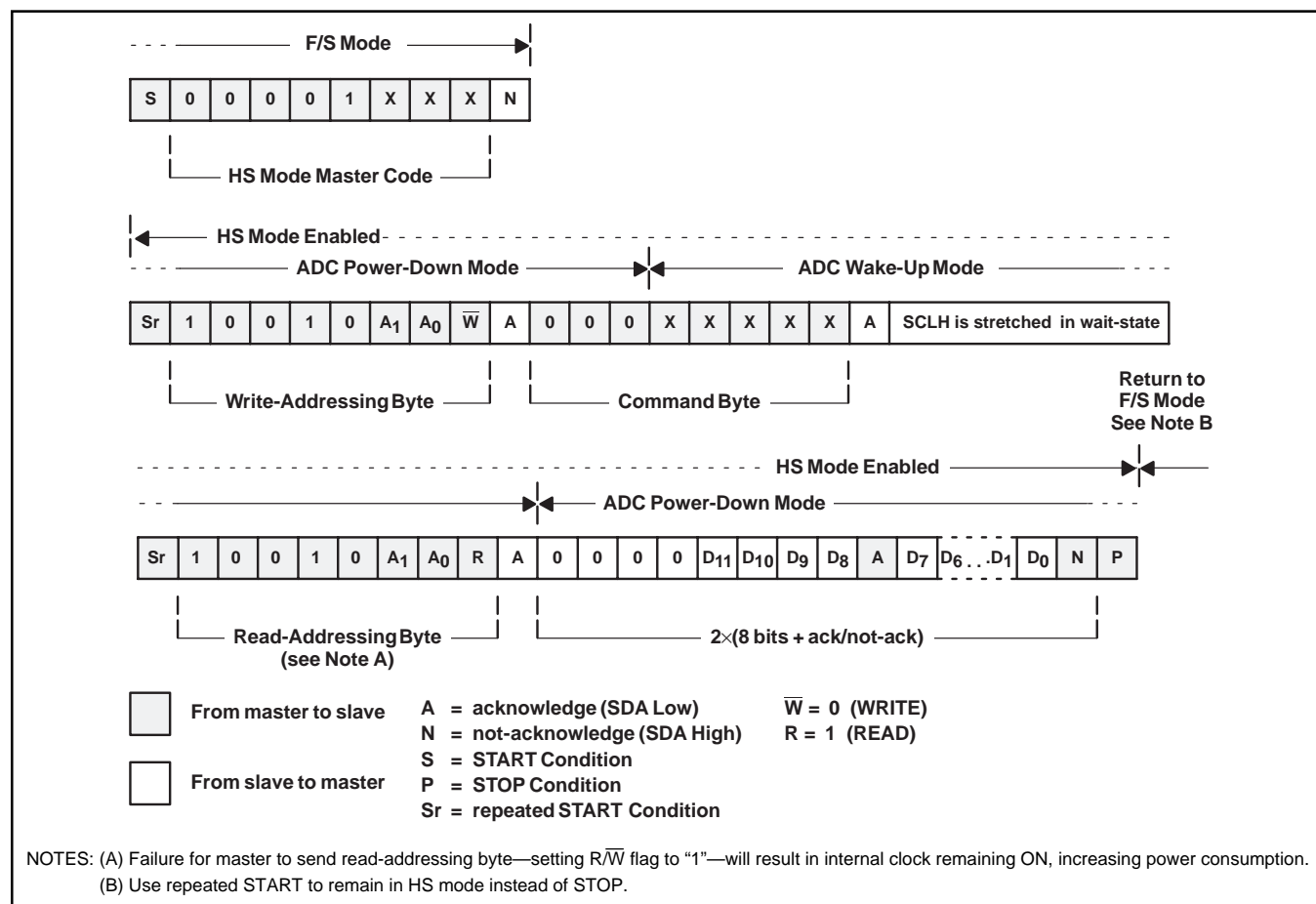

FIGURE 4. Typical Read Sequence in HS Mode.

TERMINATING A CONVERSION

There are three methods to terminate the conversion of the A/D converter in the ADS7823 after the master initiates conversion:

- 1) In normal operation sequence (see Figures 3 and 4). The conversion is terminated after the read-addressing has been received.
- 2) A STOP condition will always terminate a conversion. It will also terminate the HS mode returning the ADS7823 to the F/S mode.
- 3) A not-acknowledge by the ADS7823 following a second command byte will end a conversion.

LAYOUT

For optimum performance, care should be taken with the physical layout of the ADS7823 circuitry. The basic SAR architecture is sensitive to glitches or sudden changes on the power supply, reference, ground connections, and digital inputs that occur just prior to latching the output of the analog comparator. Therefore, during any single conversion for an “n-bit” SAR converter, there are n “windows” in which large

external transient voltages can easily affect the conversion result. Such glitches might originate from switching power supplies, nearby digital logic, and high-power devices.

With this in mind, power to the ADS7823 should be clean and well bypassed. A 0.1 μ F ceramic bypass capacitor should be placed as close to the device as possible. A 1 μ F to 10 μ F capacitor may also be needed if the impedance of the connection between +V_{DD} and the power supply is high.

The ADS7823 architecture offers no inherent rejection of noise or voltage variation in regards to using an external reference input. This is of particular concern when the reference input is tied to the power supply. Any noise and ripple from the supply will appear directly in the digital results. While high-frequency noise can be filtered out, voltage variation due to line frequency (50Hz or 60Hz) can be difficult to remove.

The GND pin should be connected to a clean ground point. In many cases, this will be the “analog” ground. Avoid connections that are too near the grounding point of a microcontroller or digital signal processor. The ideal layout will include an analog ground plane dedicated to the converter and associated analog circuitry.

PACKAGING INFORMATION

Orderable Device	Status (1)	Package Type	Package Drawing	Pins	Package Qty	Eco Plan (2)	Lead finish/ Ball material (6)	MSL Peak Temp (3)	Op Temp (°C)	Device Marking (4/5)	Samples
ADS7823E/250	ACTIVE	VSSOP	DGK	8	250	RoHS & Green	Call TI	Level-2-260C-1 YEAR	-40 to 85	B23	Samples
ADS7823E/2K5	ACTIVE	VSSOP	DGK	8	2500	RoHS & Green	Call TI	Level-2-260C-1 YEAR		B23	Samples
ADS7823EB/250	ACTIVE	VSSOP	DGK	8	250	RoHS & Green	Call TI	Level-2-260C-1 YEAR		B23	Samples
ADS7823EB/250G4	ACTIVE	VSSOP	DGK	8	250	RoHS & Green	Call TI	Level-2-260C-1 YEAR		B23	Samples
ADS7823EB/2K5	ACTIVE	VSSOP	DGK	8	2500	RoHS & Green	Call TI	Level-2-260C-1 YEAR		B23	Samples

(1) The marketing status values are defined as follows:

ACTIVE: Product device recommended for new designs.

LIFEBUY: TI has announced that the device will be discontinued, and a lifetime-buy period is in effect.

NRND: Not recommended for new designs. Device is in production to support existing customers, but TI does not recommend using this part in a new design.

PREVIEW: Device has been announced but is not in production. Samples may or may not be available.

OBSELETE: TI has discontinued the production of the device.

(2) **RoHS:** TI defines "RoHS" to mean semiconductor products that are compliant with the current EU RoHS requirements for all 10 RoHS substances, including the requirement that RoHS substance do not exceed 0.1% by weight in homogeneous materials. Where designed to be soldered at high temperatures, "RoHS" products are suitable for use in specified lead-free processes. TI may reference these types of products as "Pb-Free".

RoHS Exempt: TI defines "RoHS Exempt" to mean products that contain lead but are compliant with EU RoHS pursuant to a specific EU RoHS exemption.

Green: TI defines "Green" to mean the content of Chlorine (Cl) and Bromine (Br) based flame retardants meet JS709B low halogen requirements of <=1000ppm threshold. Antimony trioxide based flame retardants must also meet the <=1000ppm threshold requirement.

(3) MSL, Peak Temp. - The Moisture Sensitivity Level rating according to the JEDEC industry standard classifications, and peak solder temperature.

(4) There may be additional marking, which relates to the logo, the lot trace code information, or the environmental category on the device.

(5) Multiple Device Markings will be inside parentheses. Only one Device Marking contained in parentheses and separated by a "~" will appear on a device. If a line is indented then it is a continuation of the previous line and the two combined represent the entire Device Marking for that device.

(6) Lead finish/Ball material - Orderable Devices may have multiple material finish options. Finish options are separated by a vertical ruled line. Lead finish/Ball material values may wrap to two lines if the finish value exceeds the maximum column width.

Important Information and Disclaimer: The information provided on this page represents TI's knowledge and belief as of the date that it is provided. TI bases its knowledge and belief on information provided by third parties, and makes no representation or warranty as to the accuracy of such information. Efforts are underway to better integrate information from third parties. TI has taken and continues to take reasonable steps to provide representative and accurate information but may not have conducted destructive testing or chemical analysis on incoming materials and chemicals. TI and TI suppliers consider certain information to be proprietary, and thus CAS numbers and other limited information may not be available for release.

In no event shall TI's liability arising out of such information exceed the total purchase price of the TI part(s) at issue in this document sold by TI to Customer on an annual basis.

TAPE AND REEL INFORMATION
REEL DIMENSIONS

TAPE DIMENSIONS

A0	Dimension designed to accommodate the component width
B0	Dimension designed to accommodate the component length
K0	Dimension designed to accommodate the component thickness
W	Overall width of the carrier tape
P1	Pitch between successive cavity centers

TAPE AND REEL INFORMATION

*All dimensions are nominal

Device	Package Type	Package Drawing	Pins	SPQ	Reel Diameter (mm)	Reel Width W1 (mm)	A0 (mm)	B0 (mm)	K0 (mm)	P1 (mm)	W (mm)	Pin1 Quadrant
ADS7823E/250	VSSOP	DGK	8	250	180.0	12.4	5.3	3.4	1.4	8.0	12.0	Q1
ADS7823E/2K5	VSSOP	DGK	8	2500	330.0	12.4	5.3	3.4	1.4	8.0	12.0	Q1
ADS7823EB/250	VSSOP	DGK	8	250	180.0	12.4	5.3	3.4	1.4	8.0	12.0	Q1
ADS7823EB/2K5	VSSOP	DGK	8	2500	330.0	12.4	5.3	3.4	1.4	8.0	12.0	Q1

TAPE AND REEL BOX DIMENSIONS

*All dimensions are nominal

Device	Package Type	Package Drawing	Pins	SPQ	Length (mm)	Width (mm)	Height (mm)
ADS7823E/250	VSSOP	DGK	8	250	210.0	185.0	35.0
ADS7823E/2K5	VSSOP	DGK	8	2500	367.0	367.0	35.0
ADS7823EB/250	VSSOP	DGK	8	250	210.0	185.0	35.0
ADS7823EB/2K5	VSSOP	DGK	8	2500	367.0	367.0	35.0

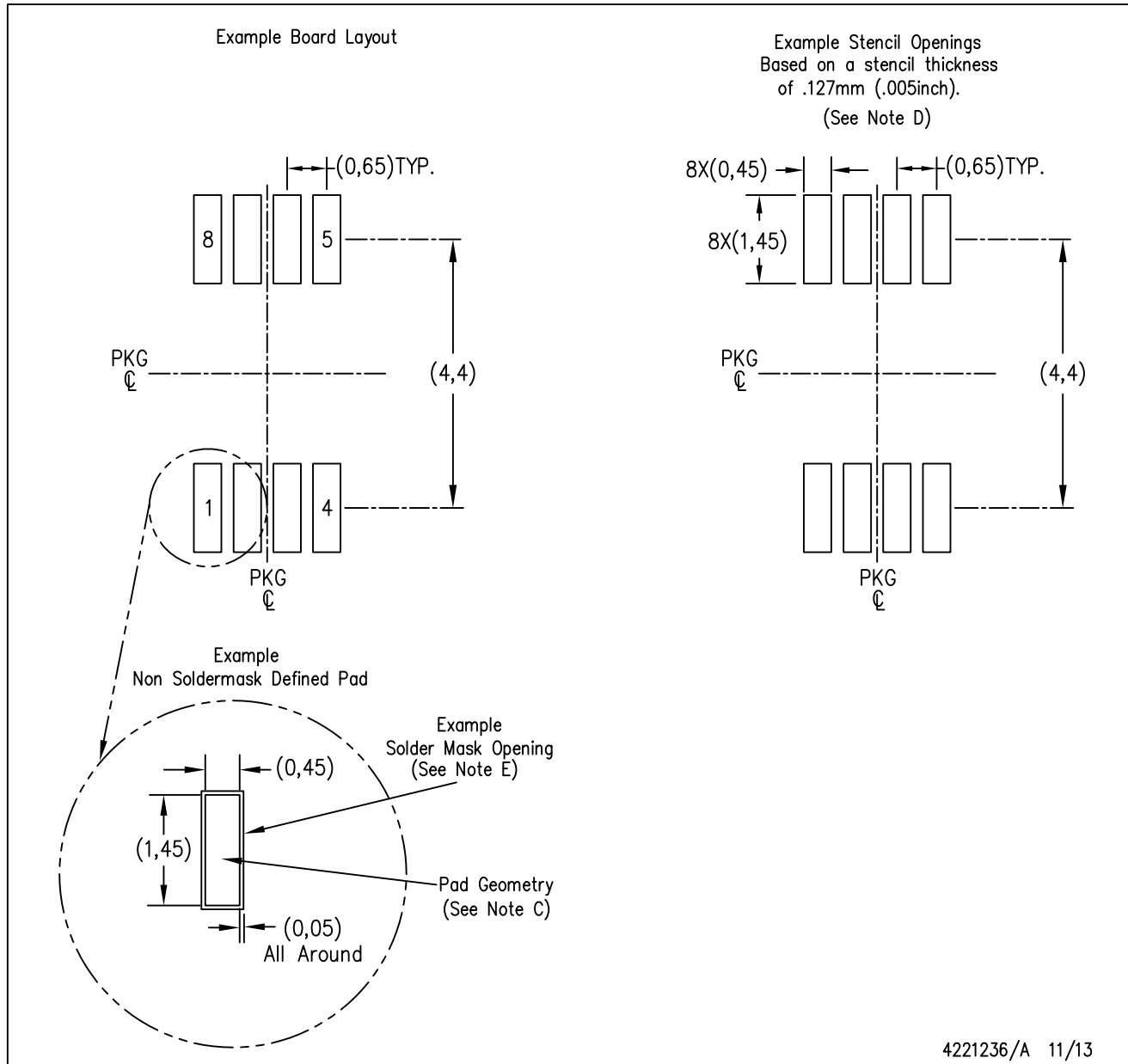

- NOTES:
- A. All linear dimensions are in millimeters.
 - B. This drawing is subject to change without notice.
 - C. Publication IPC-7351 is recommended for alternate designs.
 - D. Laser cutting apertures with trapezoidal walls and also rounding corners will offer better paste release. Customers should contact their board assembly site for stencil design recommendations. Refer to IPC-7525 for other stencil recommendations.
 - E. Customers should contact their board fabrication site for solder mask tolerances between and around signal pads.

IMPORTANT NOTICE AND DISCLAIMER

TI PROVIDES TECHNICAL AND RELIABILITY DATA (INCLUDING DATA SHEETS), DESIGN RESOURCES (INCLUDING REFERENCE DESIGNS), APPLICATION OR OTHER DESIGN ADVICE, WEB TOOLS, SAFETY INFORMATION, AND OTHER RESOURCES "AS IS" AND WITH ALL FAULTS, AND DISCLAIMS ALL WARRANTIES, EXPRESS AND IMPLIED, INCLUDING WITHOUT LIMITATION ANY IMPLIED WARRANTIES OF MERCHANTABILITY, FITNESS FOR A PARTICULAR PURPOSE OR NON-INFRINGEMENT OF THIRD PARTY INTELLECTUAL PROPERTY RIGHTS.

These resources are intended for skilled developers designing with TI products. You are solely responsible for (1) selecting the appropriate TI products for your application, (2) designing, validating and testing your application, and (3) ensuring your application meets applicable standards, and any other safety, security, regulatory or other requirements.

These resources are subject to change without notice. TI grants you permission to use these resources only for development of an application that uses the TI products described in the resource. Other reproduction and display of these resources is prohibited. No license is granted to any other TI intellectual property right or to any third party intellectual property right. TI disclaims responsibility for, and you will fully indemnify TI and its representatives against, any claims, damages, costs, losses, and liabilities arising out of your use of these resources.

TI's products are provided subject to [TI's Terms of Sale](#) or other applicable terms available either on ti.com or provided in conjunction with such TI products. TI's provision of these resources does not expand or otherwise alter TI's applicable warranties or warranty disclaimers for TI products.

TI objects to and rejects any additional or different terms you may have proposed.

Mailing Address: Texas Instruments, Post Office Box 655303, Dallas, Texas 75265
Copyright © 2021, Texas Instruments Incorporated