

具有 I²C 一次性可编程 (OTP) ROM 电流调整的两灯串发光二极管 (LED)

 查询样品: **TPS92660**

特性

- 输入电压: 高达 **80V**
- 两输出 **LED** 电流控制器
- 通过带有 **I²C** 接口的一次性可编程 (OTP) ROM 来调整 **LED** 电流
- 针对每个 **LED** 灯串脉宽调制 (**PWM**) 调光的可调 **SADJ** 和 **LADJ** 引脚
- 输入欠压闭锁和输出过压保护
- 使能接通/关闭
- 精确的 **3.0V** 基准电压
- 效率大于 **95%**
- 热关断保护
- **20** 引脚薄型小尺寸 (**TSSOP**) 外露垫封装

应用范围

- 专业照明
- 工业用和商用照明
- 通用照明

说明

TPS92660 是一款双输出 LED 驱动器, 此驱动器具有用于 LED 电流调整的一次性可编程 (OTP) ROM 和 I²C 接口。此电流调整为 LED 灯具制造商提供了一个生产 LED 照明灯具的方法, 这个方法可在不对 LED 灯进行颜色分级的情况下保持恒定的流明输出。

此器件的一个输出是非同步降压控制器, 此控制器被用来调节较高功率白光 LED 的电流。此器件的另外一个输出是线性稳压器控制器, 此控制器被用来调节较低功率红光 LED 的电流。通过将白光 LED 与红光 LED 混用, TPS92660 被用于受控 CCT (相关色温) LED 灯应用。

此器件采用 20 引脚, TSSOP 外露垫封装。

典型应用

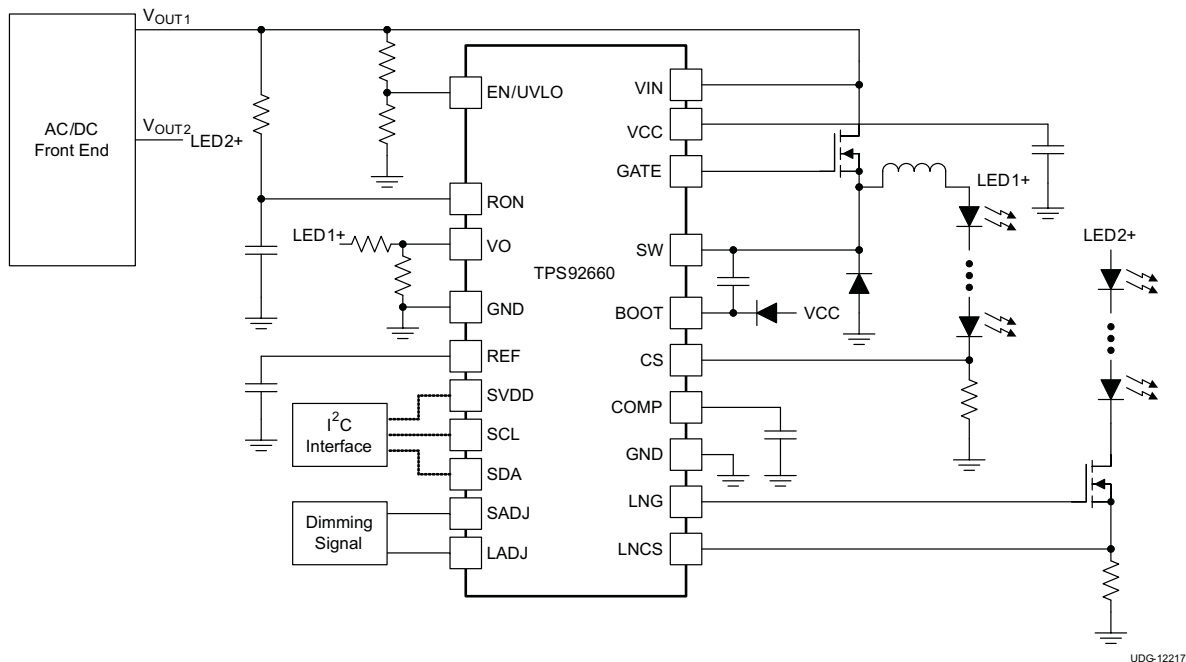

UDG-12217



Please be aware that an important notice concerning availability, standard warranty, and use in critical applications of Texas Instruments semiconductor products and disclaimers thereto appears at the end of this data sheet.

All trademarks are the property of their respective owners.



These devices have limited built-in ESD protection. The leads should be shorted together or the device placed in conductive foam during storage or handling to prevent electrostatic damage to the MOS gates.

ORDERING INFORMATION⁽¹⁾ (2)

T _J	PACKAGE	ORDERABLE DEVICE NUMBER	PINS	OUTPUT SUPPLY	MINIMUM ORDER QUANTITY
-40°C to 125°C	TSSOP exposed pad	TPS92660PWP	20	Tube	73
		TPS92660PWPR		Tape and Reel	2500

- (1) For the most current package and ordering information, see the Package Option Addendum at the end of this document, or visit the TI website at www.ti.com.
- (2) Package drawings, standard packing quantities, thermal data, symbolization, and PCB design guidelines are available at www.ti.com/sc/package.

ABSOLUTE MAXIMUM RATINGS⁽¹⁾

over operating free-air temperature range (unless otherwise noted)

		VALUE		UNIT
		MIN	MAX	
Supply voltage	VCC	-0.3	14	V
Input voltage range ⁽²⁾	VIN, UVLO/EN	-0.3	80	
	BOOT to SW	-0.3	14	
	SADJ, LADJ, RON, VO, COMP, CS, LNCS	-0.3	6	
	SW	-2.0	80	
	BOOT	-0.3	90	
	SVDD, SCL, SDA	-0.3	5.5	
Electrostatic discharge	Human body model (HBM) QSS 009-105 (JESD22-A114A)		2000	V
	Charged device model (CDM) QSS 009-147 (JESD22-C101B.01)		750	
Junction temperature range, T _J ⁽³⁾			165	°C
Storage temperature range, T _{stg}		-55	150	
Lead temperature range, soldering, 10 s			260	

- (1) Stresses beyond those listed under *Absolute Maximum Ratings* may cause permanent damage to the device. These are stress ratings only, and functional operation of the device at these or any other conditions beyond those indicated under *Recommended Operating Conditions* is not implied. Exposure to absolute-maximum-rated conditions for extended periods may affect device reliability.
- (2) All voltage values are with respect to the network ground terminal unless otherwise noted.
- (3) Maximum junction temperature is internally limited

THERMAL INFORMATION

THERMAL METRIC ⁽¹⁾		TPS92660	UNITS
		TSSOP exposed pad (PWP)	
		20 PINS	
θ_{JA}	Junction-to-ambient thermal resistance ⁽²⁾	36.9	°C/W
θ_{JcTop}	Junction-to-case (top) thermal resistance ⁽³⁾	22.7	
θ_{JB}	Junction-to-board thermal resistance ⁽⁴⁾	18.6	
Ψ_{JT}	Junction-to-top characterization parameter ⁽⁵⁾	0.6	
Ψ_{JB}	Junction-to-board characterization parameter ⁽⁶⁾	18.4	
θ_{JcBot}	Junction-to-case (bottom) thermal resistance ⁽⁷⁾	1.9	

- (1) 有关传统和新的热 度量的更多信息，请参阅 *IC 封装热量应用报告*，[SPRA953](#)。
- (2) 在 JESD51-2a 描述的环境中，按照 JESD51-7 的指定，在一个 JEDEC 标准高 K 电路板上进行仿真，从而获得自然 对流条件下的结至环境热阻。
- (3) 通过在封装顶部模拟一个冷板测试来获得结至芯片外壳（顶部）的热阻。不存在特定的 JEDEC 标准测试，但可在 ANSI SEMI 标准 G30-88 中找到内容接近的说明。
- (4) 按照 JESD51-8 中的说明，通过 在配有用于控制 PCB 温度的环形冷板夹具的环境中进行仿真，以获得结板热阻。
- (5) 结至顶部特征参数， Ψ_{JT} ，估算真实系统中器件的结温，并使用 JESD51-2a（第 6 章和第 7 章）中 描述的程序从仿真数据中提取出该参数以便获得 θ_{JA} 。
- (6) 结至电路板特征参数， Ψ_{JB} ，估算真实系统中器件的结温，并使用 JESD51-2a（第 6 章和第 7 章）中 描述的程序从仿真数据中提取出该参数以便获得 θ_{JA} 。
- (7) 通过在外露（电源）焊盘上进行冷板测试仿真来获得 结至芯片外壳（底部）热阻。不存在特定的 JEDEC 标准 测试，但可在 ANSI SEMI 标准 G30-88 中找到内容接近的说明。

RECOMMENDED OPERATING CONDITIONS

over operating free-air temperature range (unless otherwise noted)

		MIN	MAX	UNIT
V_{VIN}	Input Voltage	8.6	80	V
V_{SVDD}	I ² C VDD	2.7	5.5	V
V_{VO}	Output voltage sense for control and protection	0	2.5	V
$V_{UVLO/EN}$	Enable/Under Voltage lock-out	0	5.5	V
V_{SADJ}	Switching regulator analog or PWM LED current adjust	0	5.5	V
V_{LADJ}	Linear regulator analog or PWM LED current adjust	0	5.5	V
V_{RON}	Resistor and capacitor sets switching frequency of device	0	5.5	V
T_J	Operating junction temperature	-40	125	°C

ELECTRICAL CHARACTERISTICS

Unless otherwise specified $V_{IN} = 48\text{ V}$, $-40^{\circ}\text{C} < T_A = T_J < 125^{\circ}\text{C}$.

PARAMETER		CONDITIONS	MIN	TYP	MAX	UNITS
V_{CC} REGULATOR (VCC)						
V _{CC}	V _{CC} Voltage		7.75	8.2	8.55	V
I _{VCC}	V _{CC} current limit	V _{CC} = 0	14	20	27	mA
V _{CCUVLO}	Rising threshold			6.4		V
	Falling threshold			6.1		
I _Q	Quiescent current	V _{IN} = 80 V		2.2		mA
UVLO/DEVICE ENABLE (EN/UV)						
V _{EN}	Device enable voltage threshold	V _{EN} increasing	1.14	1.2	1.26	V
V _{EN_HYS}	Enable input hysteresis			20		mV
I _{EN}	Enable source current	V _{EN} = 0		10		μA
ON/OFF TIMER/OVER VOLTAGE PROTECTION (RON, VO)						
R _{PD_RON}	RON pull-down resistance			60	83	Ω
V _{OV}	VO pin overvoltage threshold		2.4	2.5	2.6	V
V _{OV_HYS}	VO pin overvoltage hysteresis			0.1		V
t _{ON_DLY}	RON pin to GATE delay			58		ns
t _{OFF(min)}	Minimum off-time	V _{CS} = 0 V	200	255	340	ns
t _{ON(min)}	Minimum on-time		80	120	180	ns
I²C LOGIC INTERFACE (SCL, SDA) (2.7V ≤ V_{SVDD} ≤ 5.5V)						
V _{IL}	Low-level input voltage				0.2 × V _{SVDD}	V
V _{IH}	High-level input voltage		0.8 × V _{SVDD}			V
I _L	Logic input current		-1	0	1	μA
f _{SCL}	SCL input frequency			100	200	kHz
V _{OL}	Low-level output voltage	I _{SDA} = 3 mA		0.2	0.38	V
I _L	Output leakage current	V _{SDA} = 5 V			1	μA
SWITCHER LED CURRENT SENSE (CS, COMP)						
V _{SW_REF}	Switcher LED current reference voltage	Non-programmed	196	202	209	mV
Δ V _{SW_REF}	Switcher LED current reference voltage adjust range			±40 -40		mV
I _{CS}	CS bias current				1	μA
g _M	CS amplifier transconductance			600		μA/V
V _{CS_COMP}	CS to COMP offset voltage			1.8		V
I _{COMP}	COMP source current			75		μA
	COMP sink current			75		μA
HIGH SIDE SWITCH CURRENT LIMIT (VIN, SW)						
V _{SW_LIM}	High side switch current limit (referenced from VIN)		232	275	329	mV
t _{LIM_OFF}	Current limit OFF time			280		μS
t _{LEB}	Switch current sense leading edge blank time			200		nS

ELECTRICAL CHARACTERISTICS (continued)

Unless otherwise specified $V_{IN} = 48\text{ V}$, $-40^{\circ}\text{C} < T_A = T_J < 125^{\circ}\text{C}$.

PARAMETER		CONDITIONS	MIN	TYP	MAX	UNITS
LINEAR LED CURRENT SENSE (LNCS)						
V_{LN_REF}	Linear LED current reference voltage	Non-programmed	190	200	209	mV
ΔV_{LN_REF}	LinearLED current reference voltage adjust range			+44 –50		mV
I_{LNCS}	LNCS Input bias current				1	μA
SWITCHING GATE DRIVER (GATE, BOOT, SW)						
R_{SRC_GATE}	Gate sourcing resistance	GATE = High		2		Ω
R_{SNK_GATE}	Gate sinking resistance	GATE = Low		2		Ω
V_{BOOT}	BOOT UVLO threshold	BOOT-SW rising	4.2	5.6	7.0	V
V_{BOOT_HYS}	BOOT UVLO threshold			750		mV
I_{SW_PD}	SW node pull down current			60		mA
LINEAR GATE DRIVER (LNG)						
V_{LNG_MAX}	LNG Maximum output voltage			6.3		V
V_{LNG_MIN}	LNG Minimum output voltage			1.4		V
I_{LNG_MAX}	LNG Maximum output current				5.5	mA
ANALOG/PWM DIMMING (SADJ, LADJ)						
f_{DIM}	Internal PWM dimming frequency			500		Hz
V_{tri}	SADJ triangle voltage for analog input	High		2.5		V
		Low		0.1		
	LADJ triangle voltage for analog input	High		2.5		V
		Low		0.1		
t_{TIMER}	SADJ Pulse detect timer			10		ms
	LADJ Pulse detect timer			10		
V_{ADJ}	SADJ PWM input threshold			2.7		V
	LADJ PWM input threshold			2.7		
V_{ADJ_HYS}	SADJ PWM input hysteresis			500		mV
	LADJ PWM input hysteresis			500		
I_{ADJ_PU}	SADJ Pull up current			5		μA
	LADJ Pull up current			5		
t_{SADJ}	SADJ to GATE delay	Rising		1.2		μs
		Falling		1.2		
t_{LADJ}	LADJ to LNG delay	Rising		1.2		μs
		Falling		1.2		
REFERENCE VOLTAGE (REF)						
V_{REF}	Voltage reference		2.92	3	3.08	V
I_{REF}	VREF maximum source current		1.6			mA
THERMAL SHUTDOWN						
T_{SD}	Thermal shutdown temperature			165		$^{\circ}\text{C}$
	Thermal shutdown hysteresis			25		$^{\circ}\text{C}$

DEVICE INFORMATION

**TSSOP PACKAGE
20-PINS
(TOP VIEW)**

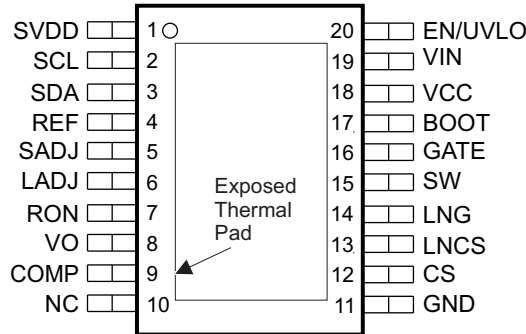

NC – No internal connection

PIN FUNCTIONS⁽¹⁾

NAME	NO.	I/O	DESCRIPTION
SVDD	1	P	I ² C VDD input.
SCL	2	I	I ² C clock input.
SDA	3	I/O	I ² C data input/output.
REF	4	O	3.0V output reference.
SADJ	5	I	Switching regulator dimming input.
LADJ	6	I	Linear regulator dimming input.
RON	7	I	Connect to resistor and capacitor which sets the switching frequency of the switching regulator.
VO	8	I	Output voltage sense for control and protection.
COMP	9	O	Switching regulator error amplifier (EA) compensation connection.
NC	10	-	No internal connection.
GND	11	G	System ground connection.
CS	12	I	Switching regulator LED Current sense input.
LNCS	13	I	Linear regulator current sense input.
LNG	14	O	Linear FET gate driver output.
SW	15	I	Connect to the switch node of the switching regulator.
GATE	16	O	Switching controller high-side N-channel FET driver output.
BOOT	17	I	MOSFET drive bootstrap pin.
VCC	18	O	Output of internal regulator. Bypass it with 1μF minimum ceramic capacitor to GND.
VIN	19	P	Input voltage supply for device. Maximum of 80V operating voltage.
EN/UVLO	20	I	This pin is a multi function input. Enable of device, Under-voltage lock-out (UVLO).
DAP	-	-	Exposed thermal pad. Connected to the system ground. Place vias on DAP.

(1) I=Input, O=Output, P=Power, G=Ground

FUNCTIONAL BLOCK DIAGRAM

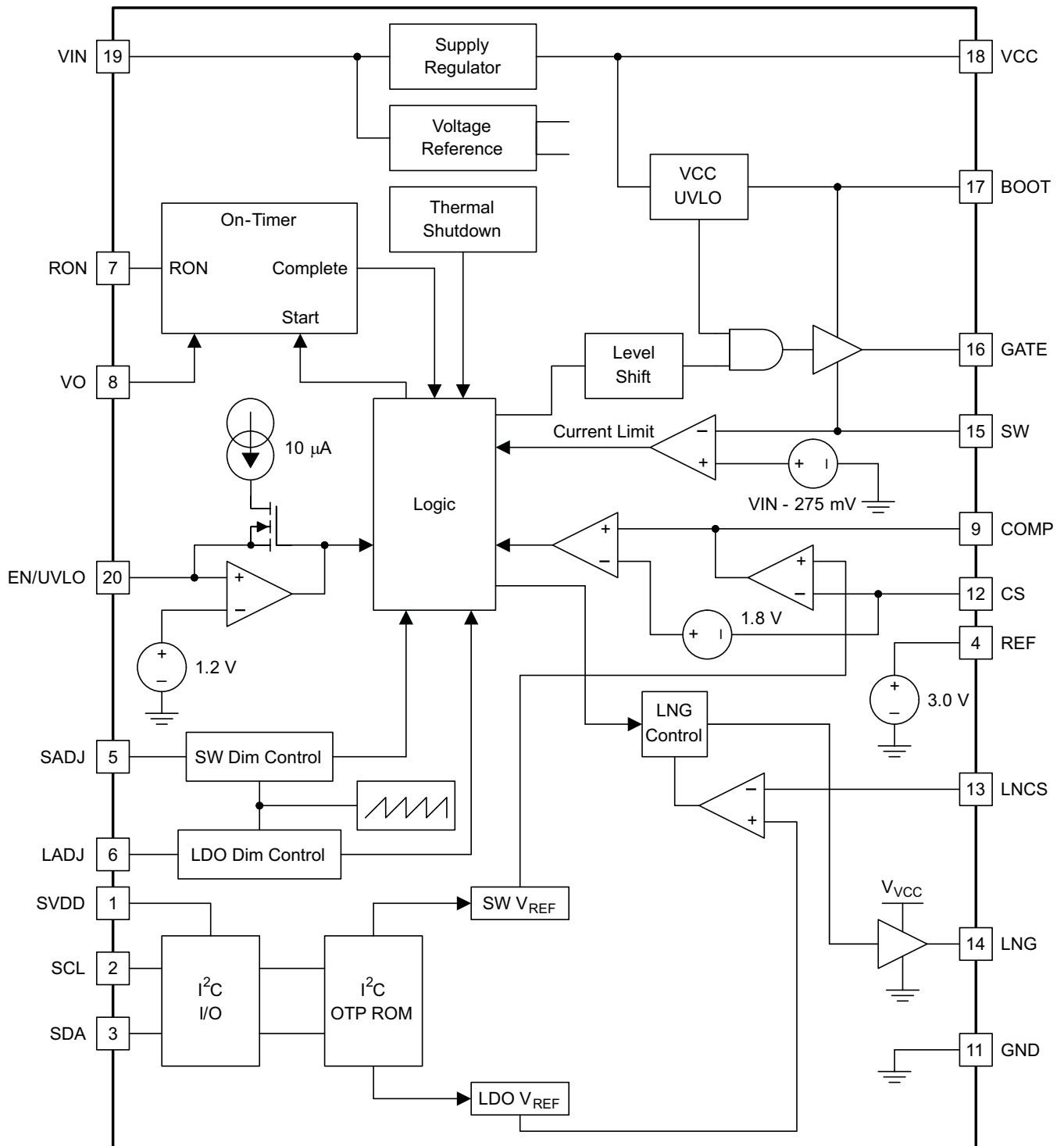

UDG-12211

TYPICAL CHARACTERISTICS

Unless otherwise stated, $-40^{\circ}\text{C} \leq T_A = T_J \leq +125^{\circ}\text{C}$, $V_{IN} = 48\text{ V}$, $R_T = 51.1\text{ k}\Omega$, $C_T = 1000\text{ pF}$, $C_{VCC} = 1\text{ }\mu\text{F}$, $C_{COMP} = 1\text{ }\mu\text{F}$

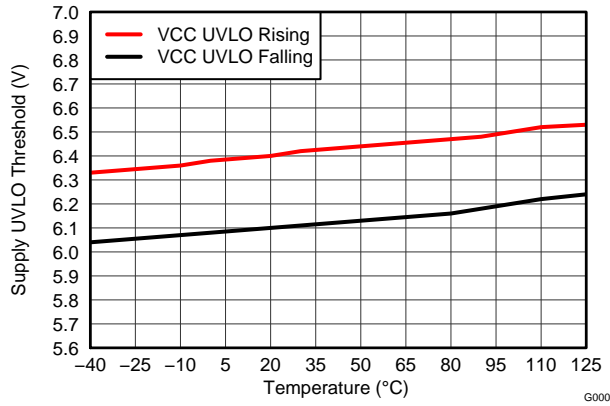

Figure 1. Supply Voltage (VCC) UVLO Threshold vs Junction Temperature

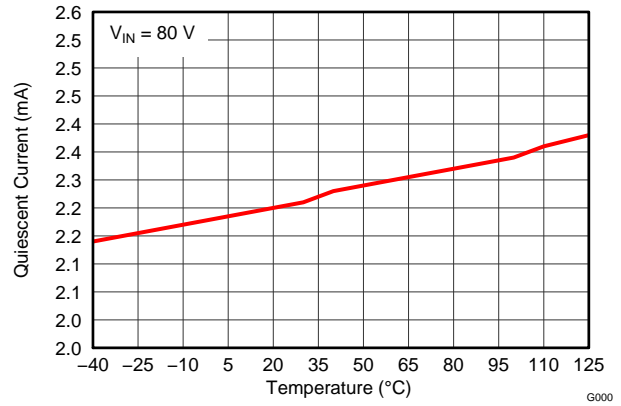

Figure 2. Quiescent Current vs Junction Temperature

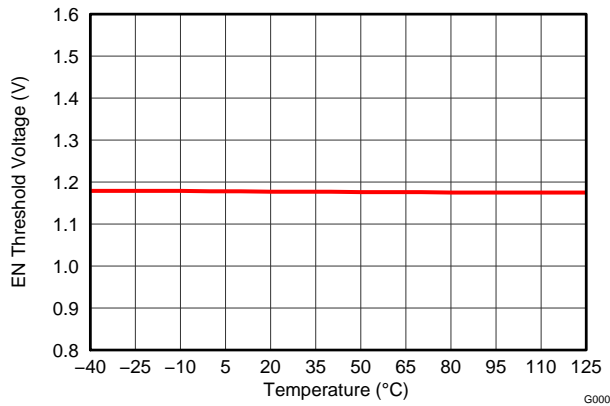

Figure 3. Enable Threshold Voltage vs Junction Temperature

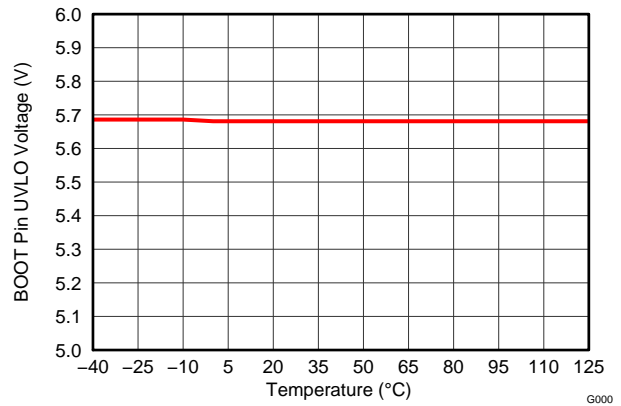

Figure 4. Boot UVLO Threshold vs Junction Temperature

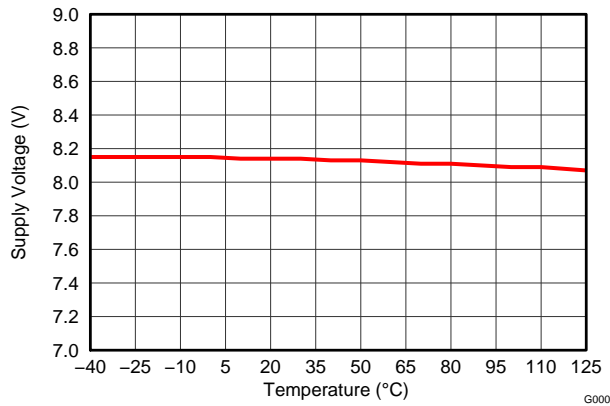

Figure 5. Supply Voltage (VCC) vs Junction Temperature

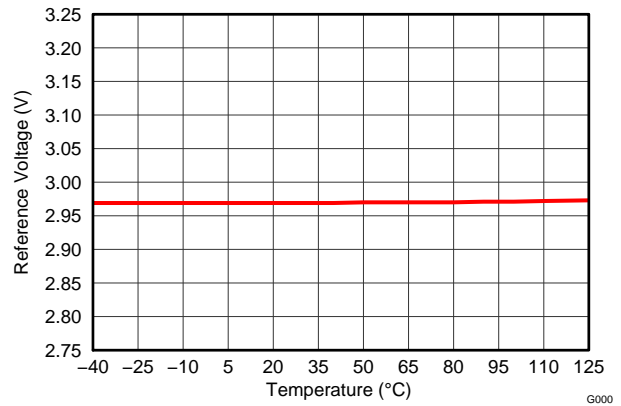

Figure 6. Voltage Reference vs Junction Temperature

TYPICAL CHARACTERISTICS

Unless otherwise stated, $-40^{\circ}\text{C} \leq T_A = T_J \leq +125^{\circ}\text{C}$, $V_{IN} = 48\text{ V}$, $R_T = 51.1\text{ k}\Omega$, $C_T = 1000\text{ pF}$, $C_{VCC} = 1\text{ }\mu\text{F}$, $C_{COMP} = 1\text{ }\mu\text{F}$

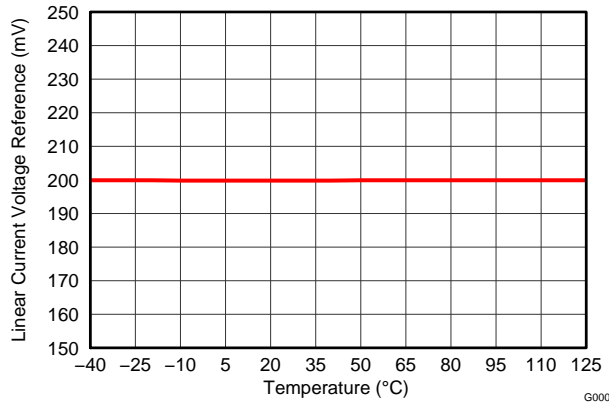

Figure 7. Linear Current Voltage Regulation vs Junction Temperature

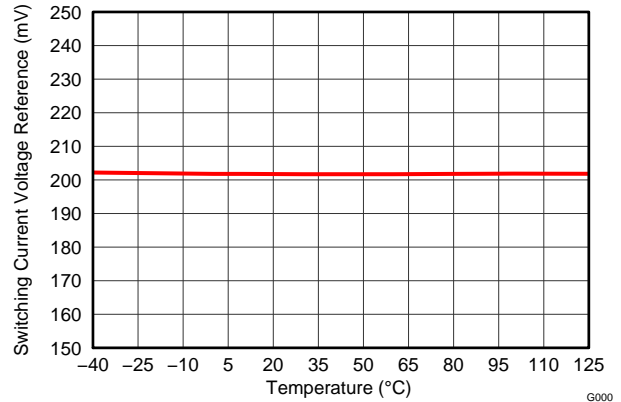

Figure 8. Switching Current Voltage Regulation vs Junction Temperature

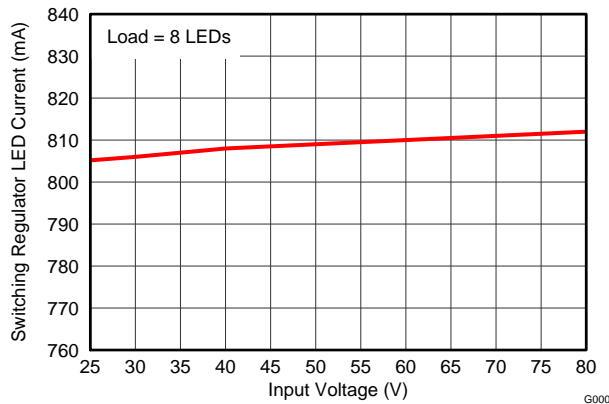

Figure 9. Switching Regulator LED Current vs Input Voltage

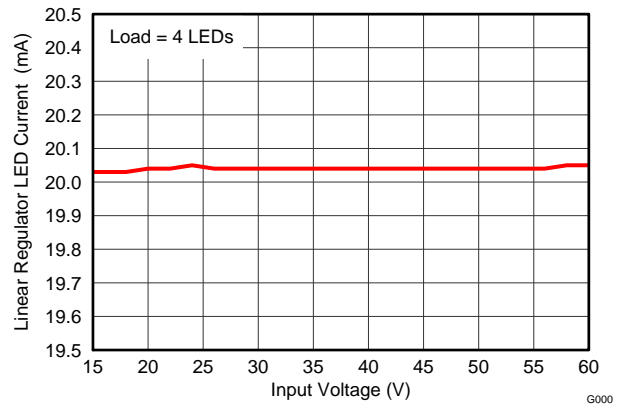

Figure 10. Linear Regulator LED Current vs Input Voltage

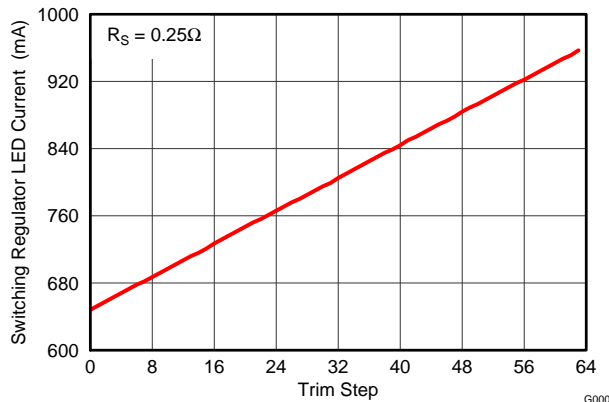

Figure 11. Switching Regulator LED Current vs I²C Trim Step

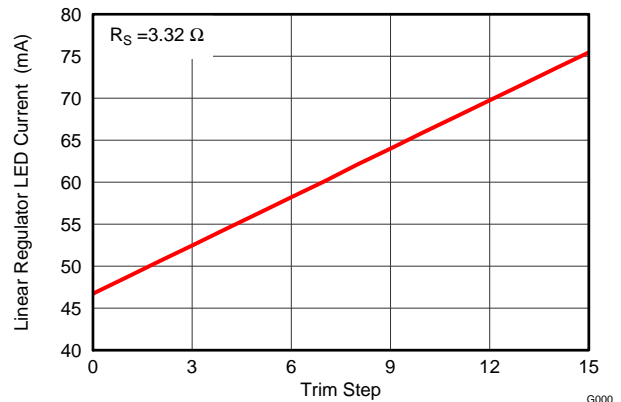

Figure 12. Linear Regulator LED Current vs I²C Trim Step

TYPICAL CHARACTERISTICS (continued)

Unless otherwise stated, $-40^{\circ}\text{C} \leq T_A = T_J \leq +125^{\circ}\text{C}$, $V_{IN} = 48\text{ V}$, $R_T = 51.1\text{ k}\Omega$, $C_T = 1000\text{ pF}$, $C_{VCC} = 1\text{ }\mu\text{F}$, $C_{COMP} = 1\text{ }\mu\text{F}$

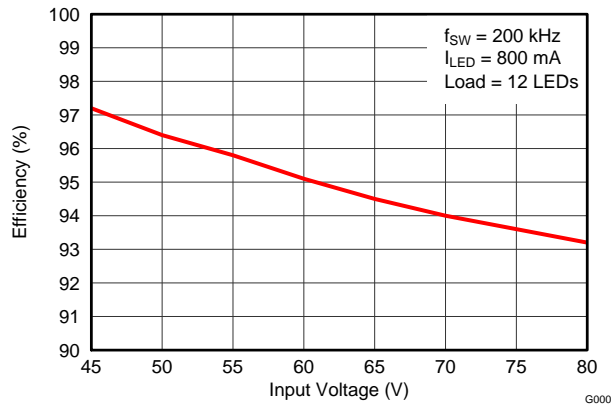

Figure 13. Switching Regulator Efficiency vs Input Voltage

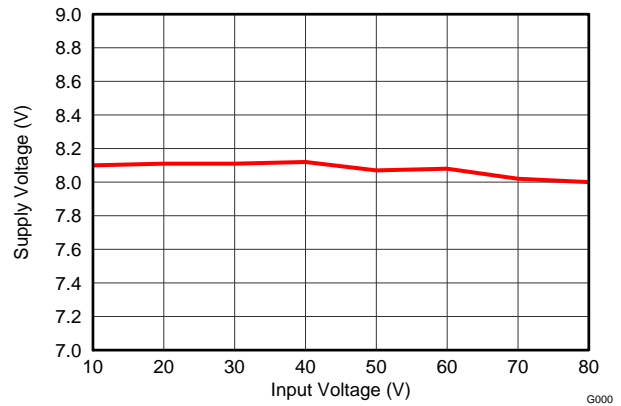

Figure 14. VCC vs Input Voltage

APPLICATION INFORMATION

Theory of Operation

The TPS92660 is a dual-channel LED current controller. It has a high-voltage, non-synchronous buck controller capable of driving an N-channel high-side MOSFET and a linear controller capable of driving an N-channel low-side MOSFET. The buck controller uses a controlled on-time (COT) control scheme to regulate the LED current. The controlled on-time varies with input and output voltage to produce pseudo-fixed frequency operation.

The TPS92660 buck controller also employs a transconductance error amplifier that regulates average the LED current. When the buck converter operates in continuous conduction mode (CCM) the controlled on-time maintains a relatively constant switching frequency over the change of input and output voltages. The linear controller regulates the LED current by controlling the gate voltage of the N-channel low side MOSFET. This MOSFET is connected in series with the LED string and operates in the linear region when LED current is in regulation. The linear controller senses the LED current and compares it with the internal reference voltage (default 200 mV without OTP trim) to generate the MOSFET gate-drive voltage.

Figure 15 shows a simplified version of the feedback system used to control the current through the LED string connected to the buck converter. The LED current flows through the current sense resistor R_{SNS} and generates the current sense voltage. This voltage is fed to the CS pin. Inside the IC, the current sense voltage is internally integrated and compared to a reference voltage. The error amplifier is a transconductance (g_M) amplifier which sources/sinks current to/from the comp pin and effectively maintains the voltage at the CS pin to be equal to the voltage V_{SW_REF} (default 202 mV without OTP trim). The comparator turns on the high-side MOSFET of the buck converter when the CS voltage falls below the COMP pin voltage minus 1.8V level shift.

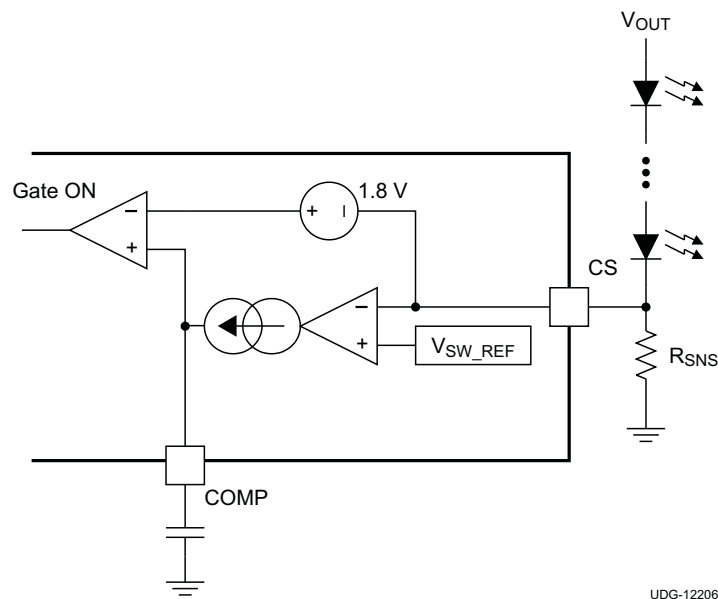

Figure 15. Current Control Circuitry

Figure 16 shows how the MOSFET conducts for a controlled on-time (t_{ON}), set by the external resistor R_T , the external capacitor C_T , the input voltage and the output voltage. At the conclusion of the controlled on-time period, the MOSFET turns off and must remain off for a minimum of 255 ns. Once the minimum off-time period is complete, the comparator compares the CS voltage with the COMP pin voltage again to start the next cycle.

A capacitor with a value of 0.1 μF or higher is recommended between the COMP pin and GND. This compensation capacitor provides a dominant pole in the feedback loop and makes the control loop stable.

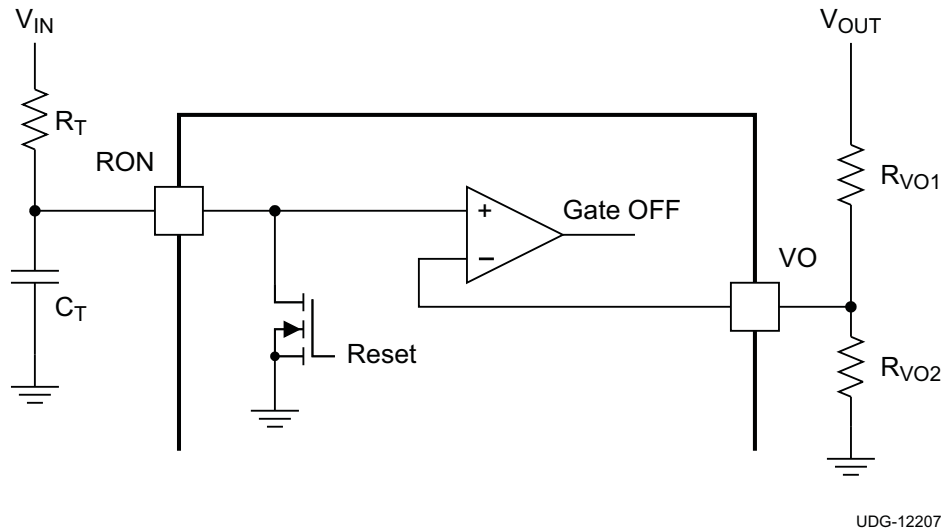

Figure 16. On-Time Circuitry

Switching Frequency

The TPS92660 does not contain a clock, however the on-time is modulated in proportion to both the input voltage and the output voltage in order to maintain a relatively constant switching frequency.

The on-time circuitry is shown in [Figure 16](#). Estimate the switching frequency based on timing resistor R_T , timing capacitor C_T and the resistor divider of R_{VO1} and R_{VO2} . [Equation 1](#) and [Equation 2](#) show how to derive the switching frequency estimation.

$$f_{SW} = \frac{D}{t_{ON}} \quad (1)$$

$$D = \frac{V_{OUT}}{V_{IN}} \quad (2)$$

The on-time period ends when the voltage at the capacitor C_T is charged to the voltage on the VO pin. The charging current ratio is shown in [Equation 3](#).

$$I_{CHRG} = \frac{V_{IN}}{R_T} \quad (3)$$

where

- $V_{IN} \gg V_{VO}$ (3)

$$t_{ON} = \frac{R_T \times C_T}{V_{IN}} \times \frac{R_{VO2}}{(R_{VO1} + R_{VO2})} \times V_{OUT} \quad (4)$$

Use [Equation 3](#) and [Equation 4](#) to derive [Equation 5](#).

$$f_{SW} = \frac{(R_{VO1} + R_{VO2})}{R_{VO2} \times R_T \times C_T} \quad (5)$$

LED Current Setting

The current sense resistor (R_{SNS}), which is connected between the CS pin and GND, sets the LED current of the switching regulator. The current sense resistor (R_{SNSLN}), which is connected between the LNCS pin and GND, sets the LED current of the linear regulator. The average LED current is calculated using [Equation 6](#) and [Equation 7](#).

[Equation 6](#) shows the calculation for the switching regulator current.

$$I_{LED_SW} = \frac{V_{SW_REF}}{R_{SNS}}$$

where

- V_{SW_REF} is the switching regulator reference voltage which is default 202 mV without OTP trim (6)

Equation 7 shows the linear regulator current calculation.

$$I_{LED_LN} = \frac{V_{LN_REF}}{R_{SNS_LN}}$$

where

- V_{LN_REF} is the linear regulator reference voltage which is default 200mV without OTP trim (7)

High Voltage Bias Regulator (VCC)

The TPS92660 contains an internal low dropout linear regulator (LDO), with an 8.2V output, connected between the VIN and the VCC pins. Bypass the VCC pin to the GND pin with a 1µF ceramic capacitor connected close to the pins of the device. VCC tracks VIN until VIN reaches 8.2 V and then regulates at 8.2V as VIN increases. The TPS92660 comes out of UVLO and begins operating when VCC rises above 6.4V. The TPS92660 shuts down when VCC falls below 6.1V. The VCC regulator current limit is 20mA.

Peak Switching Current Limit

The TPS92660 contains a current limit comparator to limit the peak current of the high-side switching MOSFET. When the high-side switching MOSFET turns on, there is a 200ns leading edge blank time. After that if the voltage difference between the VIN pin and the SW pin exceeds 275 mV, the switching MOSFET is turned off for a cool down period of approximately 280µs. In the meanwhile, the COMP pin is pulled low. If the current limit condition persists, this cycle of cool down period and restarting continues, creating a low-power hiccup mode, and minimizes the thermal stress on the switching MOSFET. Equation 8 shows the peak current limit calculation.

$$I_{PEAK} = \frac{275\text{mV}}{R_{DS(on)}}$$

where

- $R_{DS(on)}$ is the on resistance of the switching MOSFET (8)

Output Open Circuit Protection

The most common failure mode for power LEDs is a broken bond wire, and the result is an open circuit. When this happens the feedback path is disconnected, and the output voltage of the switching regulator begins to rise. The VO pin voltage (which senses the output voltage of the switching regulator through a resistor divider) rises with it. When the VO pin voltage reaches 2.5 V, it triggers the output OV protection and the high-side gate driver turns off. During this time, the COMP pin is also pulled low. There is 0.1 V hysteresis on the OVP. The converter does not resume switching until the voltage on the OV pin falls below 2.4 V.

BOOT Under Voltage Lockout (UVLO)

The TPS92660 has a BOOT UVLO circuit. The switching regulator starts switching once the BOOT-SW voltage rises to 5.6 V. There is 750 mV of hysteresis on the BOOT UVLO. It stops switching when the BOOT-SW voltage falls to 4.85V. Once the BOOT UVLO is triggered, the SW pin is pulled down by an internal MOSFET, such that the boot capacitor can be recharged. The maximum pull-down current is 60mA. When the BOOT-SW voltage is charged above 5.6 V, the pull-down circuit is disabled.

Linear Regulator LED Current Control Overview

Figure 17 shows the TPS92660 linear regulator control circuit. The voltage drop across the current sense resistor R_{SNSLN} is applied on the LNCS pin. An internal operational amplifier compares this voltage with the linear regulator reference voltage. The output of the operational amplifier drives the gate of an external N-channel MOSFET. This MOSFET operates in the linear region when the LED current is in regulation.

The gate-drive voltage controls the drain-to-source voltage of the MOSFET by changing the MOSFET on-resistance. Applications must minimize the voltage difference between the linear regulator input voltage and the LED string forward voltage in order to limit the power dissipation on the MOSFET.

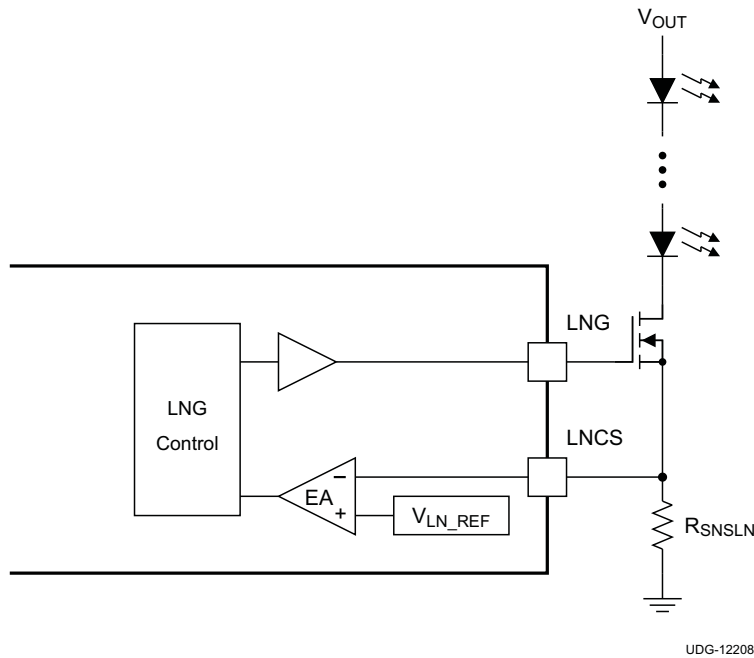

Figure 17. Linear Regulator Control

SADJ and LADJ Pins for Dimming

The SADJ pin controls the switching regulator dimming and the LADJ pin controls the linear regulator dimming. There are two different types of dimming that can be performed on those two pins.

Analog to PWM Dimming

When a DC voltage is applied on the SADJ pin, the switching regulator LED current is PWM dimmed at a fixed frequency of approximately 500 Hz. As shown in Figure 18, the PWM dimming duty cycle is linearly dependent on the input voltage level, from 0% duty cycle at 0.1 V to 100% duty cycle at 2.5 V. Similarly when a DC voltage is applied on the LADJ pin, the linear regulator LED current is PWM dimmed in the same way.

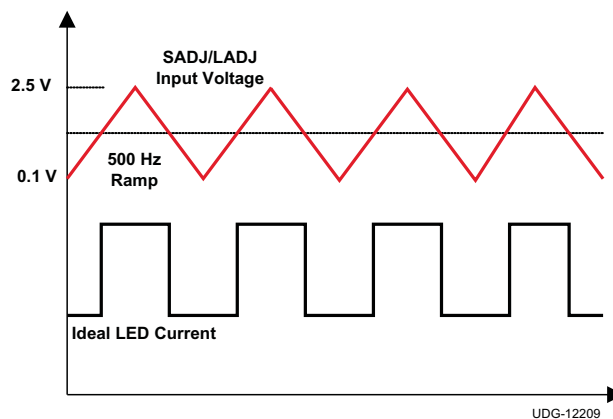

Figure 18. SADJ/LADJ Input to PWM Dimming

PWM Dimming

During PWM dimming, the signal applied on the pin is a PWM signal instead of a DC voltage. The LED current is PWM dimmed at the same frequency and duty cycle as the input PWM signal. To implement PWM dimming, the rising edges of two consecutive pulses of the input PWM signal must be less than 10ms. Once the device detects two consecutive rising edges, the regulator goes into PWM dimming mode. It turns on when the input PWM signal rises above the 2.7-V threshold and turns off when the PWM signal falls below the 2.2V threshold. For the switching regulator, when the input PWM signal is low, the regulator turns off the gate of the MOSFET and the COMP pin capacitor is disconnected. When the input PWM signal is high, the regulator starts again and the COMP pin capacitor is reconnected.

A low gate charge MOSFET is recommended for the linear regulator to prevent LED current overshoot during PWM dimming.

Input Undervoltage Lockout (UVLO)

The TPS92660 enable pin (EN/UVLO) can also be used to implement input undervoltage lockout. The input UVLO voltage is set by a resistor divider from V_{IN} to ground and is compared against a 1.2 V threshold shown in Figure 19. As soon as the input voltage is above the preset UVLO rising threshold, the internal circuitry becomes active and a 1- μ A current source at the UVLO pin is turned on. This extra current provides hysteresis to create a lower input UVLO falling threshold.

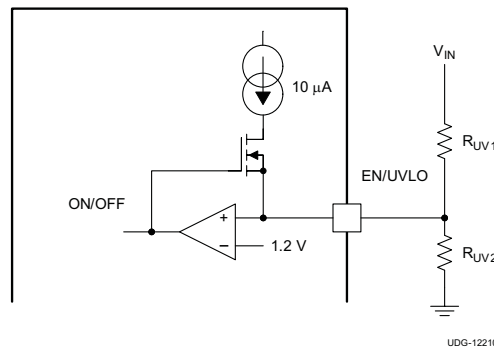

Figure 19. Input UVLO Circuit

The V_{IN} turn-on threshold is defined by Equation 9.

$$V_{IN_ON} = \frac{1.2V \times (R_{UV1} + R_{UV2})}{R_{UV2}} \quad (9)$$

$$V_{HYS} = R_{UV1} \times 10\mu A \quad (10)$$

I²C OTP ROM LED Current Trim

I²C Compatible Interface

Interface Bus Overview

The I²C compatible synchronous serial interface provides access to the programmable functions and registers on the device. This protocol uses a two-wire interface for bi-directional communications between the devices connected to the bus. The two interface lines are the serial data line (SDA), and the serial clock line (SCL). These lines should be connected to a positive supply, via a pull-up resistor, and remain HIGH even when the bus is idle. Every device on the bus is assigned a unique address and acts as either a master or a slave depending on whether it generates or receives the serial clock (SCL).

Data Transactions

One data bit is transferred during each clock pulse. Data is sampled during the high state of the serial clock (SCL). Consequently, throughout the high period, the data should remain stable. Any changes on the SDA line during the high state of SCL and in the middle of a transaction aborts the current transaction. New data should be sent during the low SCL state. This protocol permits a single data line to transfer both command/control information and data using the synchronous serial clock.

I²C Data Validity

The data on SDA line must be stable during the HIGH period of the clock signal (SCL). In other words, the state of the data line can only be changed when SCL is LOW.

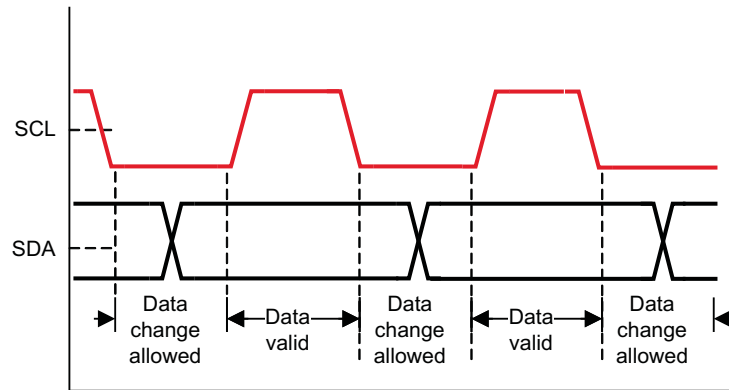

UDG-12224

Figure 20. I²C Signals: Data Validity

I²C Start and Stop Conditions

START and STOP bits classify the beginning and the end of the I²C session. START condition is defined as SDA transitioning from HIGH to LOW while SCL is HIGH. STOP condition is defined as SDA transitioning from LOW to HIGH while SCL is HIGH. The I²C master always generates START and STOP bits. Consider the I²C bus as busy after a START condition and free after a STOP condition. During data transmission, the I²C master can generate repeated START conditions. First START and repeated START conditions are functionally equivalent.

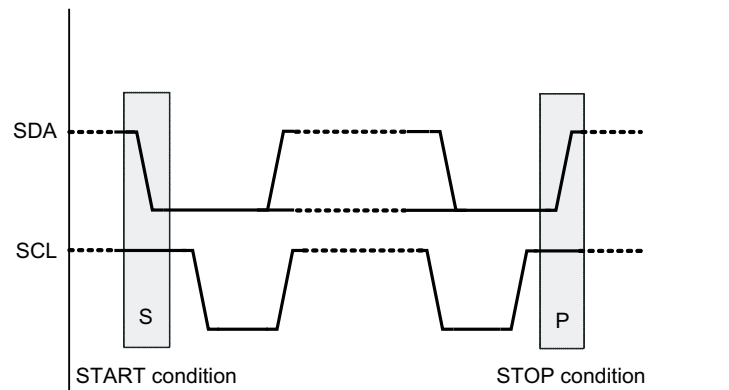

UDG-12222

Figure 21. I²C Start and Stop Conditions

I²C Addresses and Transferring Data

Every data value put on the SDA line must be eight bits long with the most significant bit (MSB) being transferred first. Each byte of data has to be followed by an acknowledge bit. The master generates the clock pulse for the acknowledge bit. The transmitter releases the SDA line (HIGH) during the acknowledge clock pulse. The receiver must pull down the SDA line during the 9th clock pulse, signifying an acknowledgement. A receiver which has been addressed must generate an acknowledge bit after each byte has been received. After the START condition, the I²C master sends a slave address. This address is seven bits long followed by an eighth bit which is a data direction bit (R/W). The I²C slave address (7 bits) for TPS92660 is 28H. For the eighth bit, a “0” indicates a WRITE and a “1” indicates a READ. The second byte selects the register to which the data is written. The third byte contains data to write to the selected register.

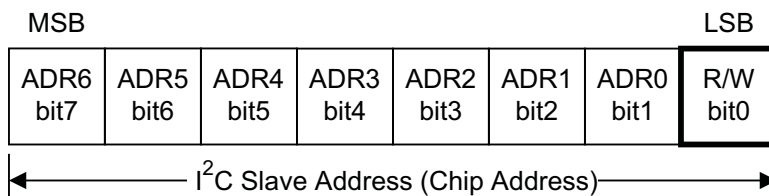

UDG-12215

Figure 22. I²C Chip Address

Register changes take effect at the SCL rising edge during the last ACK from the slave as shown in Figure 23.

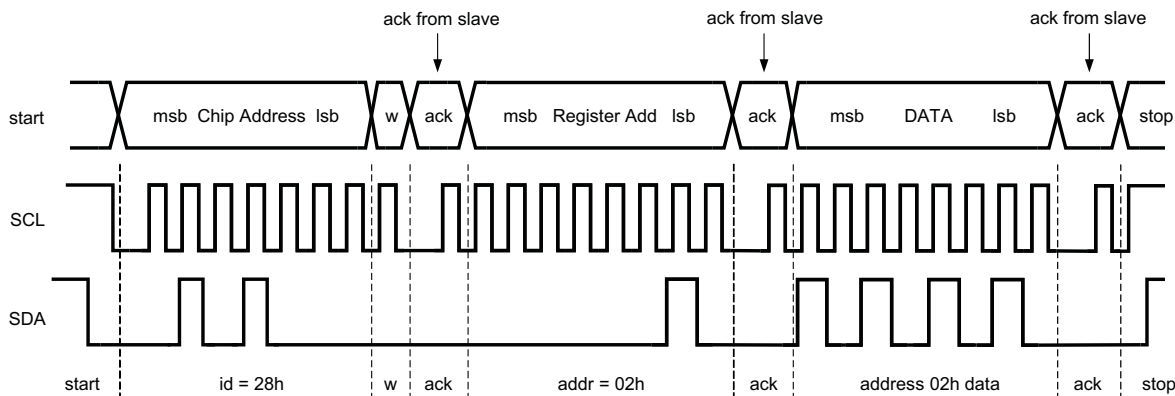

UDG-12223

w = write (SDA = “0”)
 r = read (SDA = “1”)
 ack = acknowledge (SDA pulled down by either master or slave)
 rs = repeated start
 id = 7-bit chip address, 28H for TPS92660.

Figure 23. I²C Write Cycle

A WRITE function must precede the READ function, as shown in the read cycle waveform in Figure 24.

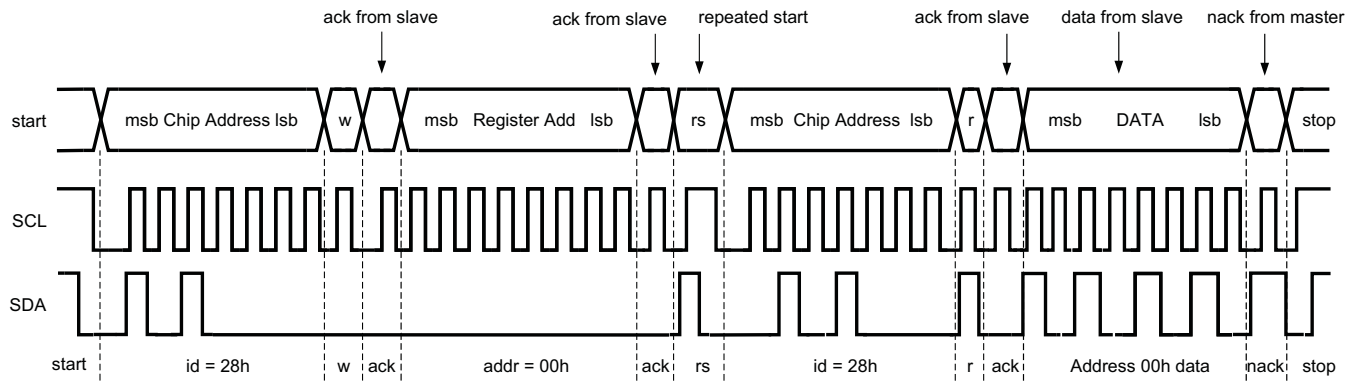

UDG-12214

Figure 24. I²C Read Cycle

I²C Timing Parameters (V_{SVDD} = 5 V)

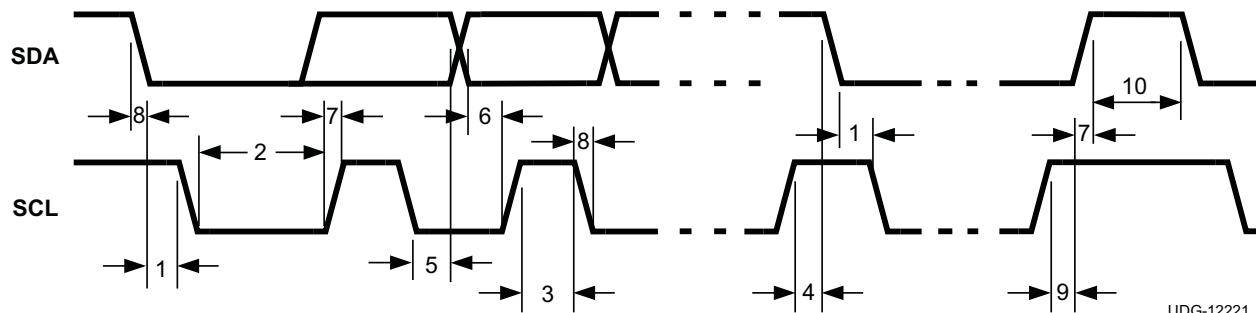

UDG-12221

Figure 25. I²C Timing Diagram

TIME PERIOD	PARAMETER ⁽¹⁾	LIMIT		UNITS
		MIN	MAX	
1	Hold time (repeated) START condition	0.6		µs
2	Clock low time	1.3		µs
3	Clock high time	600		ns
4	Setup time for a repeated START condition	600		ns
5	Data hold time (output direction)	300		ns
5	Data hold time (input direction)	0		ns
6	Data setup time	100		ns
7	Rise time of SDA and SCL	20+0.1Cb	300	ns
8	Fall time of SDA and SCL	15+0.1Cb	300	ns
9	Set-up time for STOP condition	600		ns
10	Bus free time between a STOP and a START condition	1.3		µs
Cb	Capacitive load for each bus line	10	200	pF

(1) Data specified by design. Not production tested.

I²C Register Details

The I²C bus interacts with the TPS92660 to realize the features of LED current trim. The operation of these functions requires the writing and reading of the internal registers of the TPS92660. Table 1 is the master register map of the device.

Table 1. Master Register Map

ADDR	REGISTER	D7	D6	D5	D4	D3	D2	D1	D0	DEFAULT
01h	STRIM	RSV	RSV	STRIM[5:0]						0001 1111
02h	LTRIM	RSV	RSV	RSV	RSV	LTRIM[3:0]				0000 0111
FFh	OTP ROM	RSV	RSV	RSV	BURNED	RSV	WRITE	RSV	READ	0000 1000

Register Definitions

STRIM Register Definition

ADDR	REG	D7	D6	D5	D4	D3	D2	D1	D0	DEFAULT
01h	STRIM	RSV	RSV	STRIM[5:0]						0001_1111

Bits Description

5:0 The STRIM register is meant to be programmed with possible trim values. When the best values have been found, the contents of this register may then be made permanent by burning them to OTP ROM using the OTP ROM write cycle (described below).

Upon power-up, the values in OTP ROM are loaded into this register.

Switching Regulator LED Current Trim Table

STRIM[5:0]	CURRENT CHANGE	STRIM[5:0]	CURRENT CHANGE	STRIM[5:0]	CURRENT CHANGE	STRIM[5:0]	CURRENT CHANGE
XX11 1111	-20.0%	XX10 1111	-10.0%	XX01 1111	0%	XX00 1111	10.0%
XX11 1110	-19.4%	XX10 1110	-9.38%	XX01 1110	0.625%	XX00 1110	10.6%
XX11 1101	-18.8%	XX10 1101	-8.75%	XX01 1101	1.25%	XX00 1101	11.3%
XX11 1100	-18.1%	XX10 1100	-8.13%	XX01 1100	1.88%	XX00 1100	11.9%
XX11 1011	-17.5%	XX10 1011	-7.50%	XX01 1011	2.50%	XX00 1011	12.5%
XX11 1010	-16.9%	XX10 1010	-6.88%	XX01 1010	3.13%	XX00 1010	13.1%
XX11 1001	-16.3%	XX10 1001	-6.25%	XX01 1001	3.75%	XX00 1001	13.8%
XX11 1000	-15.6%	XX10 1000	-5.63%	XX01 1000	4.38%	XX00 1000	14.4%
XX11 0111	-15.0%	XX10 0111	-5.00%	XX01 0111	5.00%	XX00 0111	15.0%
XX11 0110	-14.4%	XX10 0110	-4.38%	XX01 0110	5.63%	XX00 0110	15.6%
XX11 0101	-13.8%	XX10 0101	-3.75%	XX01 0101	6.25%	XX00 0101	16.3%
XX11 0100	-13.1%	XX10 0100	-3.13%	XX01 0100	6.88%	XX00 0100	16.9%
XX11 0011	-12.5%	XX10 0011	-2.50%	XX01 0011	7.50%	XX00 0011	17.5%
XX11 0010	-11.9%	XX10 0010	-1.88%	XX01 0010	8.13%	XX00 0010	18.1%
XX11 0001	-11.3%	XX10 0001	-1.25%	XX01 0001	8.75%	XX00 0001	18.8%
XX11 0000	-10.6%	XX10 0000	-0.625%	XX01 0000	9.38%	XX00 0000	19.4%

LTRIM Register Definition

ADDR	REG	D7	D6	D5	D4	D3	D2	D1	D0	DEFAULT
02h	LTRIM	RSV	RSV	RSV	RSV	LTRIM[3:0]				0000_0111

Bits Description

3:0 The LTRIM register is meant to be programmed with possible trim values. When the best values have been found, the contents of this register may then be made permanent by burning them to OTP ROM using the OTP ROM write cycle (described below).

Upon power-up, the values in OTP ROM are loaded into this register.

Linear Regulator LED Current Trim Table

LTRIM[3:0]	CURRENT CHANGE	LTRIM[3:0]	CURRENT CHANGE	LTRIM[3:0]	CURRENT CHANGE	LTRIM[3:0]	CURRENT CHANGE
XXXX 1111	-25.0%	XXXX 1011	-12.5%	XXXX 0111	0%	XXXX 0011	12.5%
XXXX 1110	-21.9%	XXXX 1010	-9.38%	XXXX 0110	3.13%	XXXX 0010	15.6%
XXXX 1101	-18.8%	XXXX 1001	-6.25%	XXXX 0101	6.25%	XXXX 0001	18.8%
XXXX 1100	-15.6%	XXXX 1000	-3.13%	XXXX 0100	9.38%	XXXX 0000	21.9%

OTP ROM Register Definition

ADDR	REG	D7	D6	D5	D4	D3	D2	D1	D0	DEFAULT
FFh	OTP ROM	RSV	RSV	RSV	BURNED	RSV	WRITE	RSV	READ	0000_1000

Bits Description

- 7:5 Reserved. These bits are reserved for future use. When writing to the OTP ROM register, always write '0's to these bits.
- 4 BURNED – This bit indicates that OTP ROM has been burned (when “BURNED” = 1). After burning OTP ROM, an OTP ROM read cycle must take place in order for the BURNED bit to be updated. This happens automatically upon power-up, or it can be accomplished manually by issuing an OTP ROM read command (see bit 0).
- 3 RSV
- 2 WRITE – Burning the LTRIM and STRIM register values to OTP ROM is accomplished by writing this bit to a '1', waiting at least 25ms, and then writing this bit back to '0'.
- 1 RSV
- 0 READ – To reload the STRIM and LTRIM registers from OTP ROM, write this bit to a '1'. This bit always reads back as a '0'. Writing this bit to a '1' temporarily enables the 500 kHz oscillator to perform the OTP ROM read. When the OTP ROM read is finished, the oscillator is disabled.

OTP ROM Programming

The programming of both the STRIM and the LTRIM registers to OTP ROM is performed in a single sequence as follows

1. Write the STRIM and LTRIM registers with the desired values.
2. Write a '1' to the WRITE bit of the OTP ROM register (this switches the internal EVDD from 5V to 8V).
3. Wait at least 25 ms.
4. Write a '0' to the WRITE bit (this returns EVDD to 5 V).

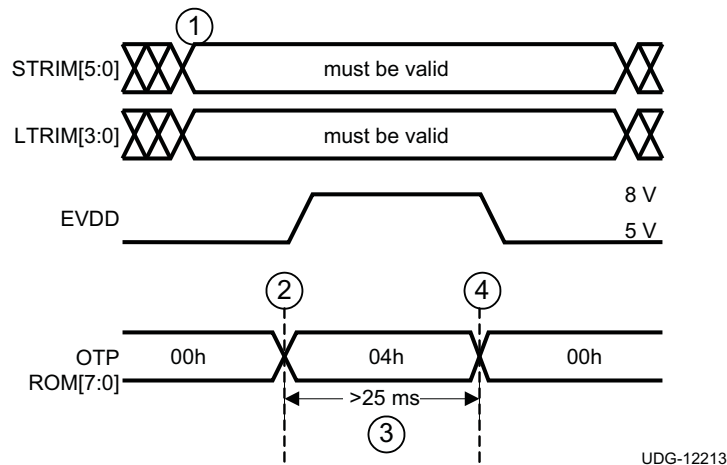

Figure 26. OTP ROM Programming Sequence

OTP ROM Reading

The EPROM is read under either of the following conditions:

- Power-on reset. Note that power-on reset starts when both EN pin and VCC voltages cross the UVLO threshold. It takes approximately 50µs to read the OTP ROM contents into the TRIM registers.
- Writing a '1' to the READ bit of the OTP ROM register. It is not necessary to clear the READ bit after writing it to a '1'.

The device temporarily enables the 500-kHz oscillator during the OTP ROM read cycle. This operation is necessary because the digital counters generate the timing for the OTP ROM read cycle. After the OTP ROM read cycle is finished, the oscillator is disabled.

Figure 27 shows a power-on OTP ROM read cycle. The device reads all OTP ROM registers simultaneously. All timing values are approximate and based on a 500-kHz internal oscillator.

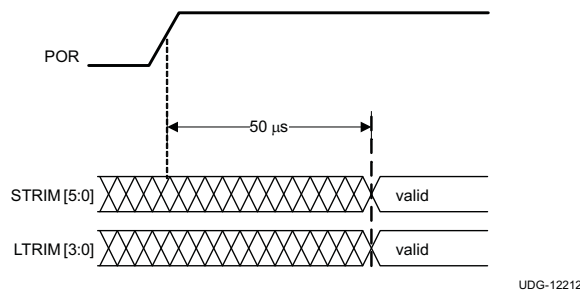

Figure 27. Power-ON OTP ROM Read Timing

Reference Voltage

The TPS92660 provides a 3.0V reference voltage which can be used in the AC/DC main power supply secondary-side control circuit.

Thermal Shutdown

Internal thermal shutdown circuitry protects the device in the event that the maximum junction temperature is exceeded. The threshold for thermal shutdown is 165°C with a 25°C hysteresis. Thermal shutdown protection disables the MOSFET drivers.

DESIGN EXAMPLE

Specifications

Switching Regulator

- Switching Regulator: (f_{SW}): 200 kHz
- Input voltage (V_{IN}): 60 V
- Output voltage (V_{OUT}): 48 V
- Charge current (I_{LED}): 500 mA
- Output overvoltage protection threshold (V_{OVP}): 60 V

Linear Regulator

- Input voltage (V_{IN}): 30 V
- Output voltage (V_{OUT}): 24 V
- Charge current (I_{LED}): 20 mA

Design Procedure

Step 1: Select Overvoltage and Timing Components R_{OV1} , R_{OV2} , R_T and C_T

$$V_{OVP} \times \frac{R_{VO2}}{(R_{VO1} + R_{VO2})} = 2.5V \quad (11)$$

- $V_{OVP} = 60V$
- Choose $R_{VO2} = 1.00k\Omega$
- The calculated $R_{VO1} = 23k\Omega$, the standard resistor with the closest value ($\pm 1\%$) is 23.2 k Ω

$$f_{SW} = \frac{(R_{VO1} + R_{VO2})}{R_{VO2} \times R_T \times C_T} \quad (12)$$

- $f_{SW} = 200KHz$
- $R_T \times C_T = 121 \times 10^{-6}$, choose $C_T = 1000pF$
- the calculated $R_T = 121k\Omega$

Step 2: Select Current Sense Resistors R_{SNS} and R_{SNS_LN}

The current sense resistor of the switching regulator $R_{SNS} = 202mV/500mA = 0.404\Omega$.

The current sense resistor of the linear regulator $R_{SNS_LN} = 200mV/20mA = 10\Omega$.

Step 3: Select Inductor

Choose inductor current ripple $\Delta I_{L_PP} = 0.15A$ (30% of I_{LED})

$$t_{ON} = \frac{V_{OUT}}{V_{IN} \times f_{SW}} = \frac{48V}{60V \times 200kHz} = 4\mu s \quad (13)$$

$$L = \frac{(V_{IN} - V_{OUT}) \times t_{ON}}{\Delta I_{L(P-P)}} = \frac{(60V - 48V) \times 4\mu s}{0.15A} = 320\mu H \quad (14)$$

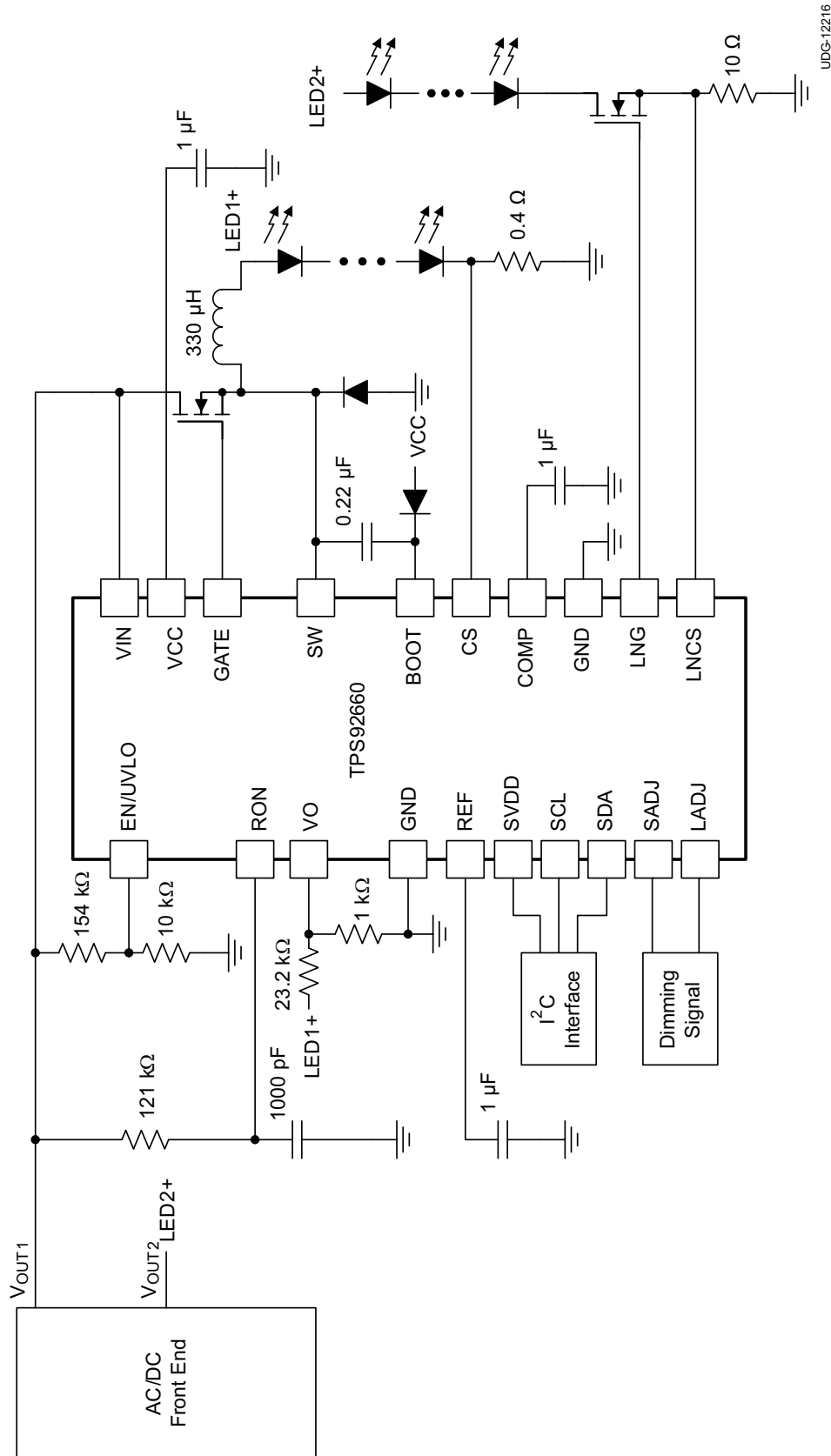

The closest standard inductor value is 330 μH .



UDG-12216

Figure 28. Design Example Application Schematic

PACKAGING INFORMATION

Orderable Device	Status (1)	Package Type	Package Drawing	Pins	Package Qty	Eco Plan (2)	Lead finish/ Ball material (6)	MSL Peak Temp (3)	Op Temp (°C)	Device Marking (4/5)	Samples
TPS92660PWP/NOPB	ACTIVE	HTSSOP	PWP	20	73	RoHS & Green	SN	Level-1-260C-UNLIM	-40 to 125	TP92660 PWP	
TPS92660PWPR/NOPB	ACTIVE	HTSSOP	PWP	20	2500	RoHS & Green	SN	Level-1-260C-UNLIM	-40 to 125	TP92660 PWP	

(1) The marketing status values are defined as follows:

ACTIVE: Product device recommended for new designs.

LIFEBUY: TI has announced that the device will be discontinued, and a lifetime-buy period is in effect.

NRND: Not recommended for new designs. Device is in production to support existing customers, but TI does not recommend using this part in a new design.

PREVIEW: Device has been announced but is not in production. Samples may or may not be available.

OBSOLETE: TI has discontinued the production of the device.

(2) **RoHS:** TI defines "RoHS" to mean semiconductor products that are compliant with the current EU RoHS requirements for all 10 RoHS substances, including the requirement that RoHS substance do not exceed 0.1% by weight in homogeneous materials. Where designed to be soldered at high temperatures, "RoHS" products are suitable for use in specified lead-free processes. TI may reference these types of products as "Pb-Free".

RoHS Exempt: TI defines "RoHS Exempt" to mean products that contain lead but are compliant with EU RoHS pursuant to a specific EU RoHS exemption.

Green: TI defines "Green" to mean the content of Chlorine (Cl) and Bromine (Br) based flame retardants meet JS709B low halogen requirements of <=1000ppm threshold. Antimony trioxide based flame retardants must also meet the <=1000ppm threshold requirement.

(3) MSL, Peak Temp. - The Moisture Sensitivity Level rating according to the JEDEC industry standard classifications, and peak solder temperature.

(4) There may be additional marking, which relates to the logo, the lot trace code information, or the environmental category on the device.

(5) Multiple Device Markings will be inside parentheses. Only one Device Marking contained in parentheses and separated by a "~" will appear on a device. If a line is indented then it is a continuation of the previous line and the two combined represent the entire Device Marking for that device.

(6) Lead finish/Ball material - Orderable Devices may have multiple material finish options. Finish options are separated by a vertical ruled line. Lead finish/Ball material values may wrap to two lines if the finish value exceeds the maximum column width.

Important Information and Disclaimer:The information provided on this page represents TI's knowledge and belief as of the date that it is provided. TI bases its knowledge and belief on information provided by third parties, and makes no representation or warranty as to the accuracy of such information. Efforts are underway to better integrate information from third parties. TI has taken and continues to take reasonable steps to provide representative and accurate information but may not have conducted destructive testing or chemical analysis on incoming materials and chemicals. TI and TI suppliers consider certain information to be proprietary, and thus CAS numbers and other limited information may not be available for release.

In no event shall TI's liability arising out of such information exceed the total purchase price of the TI part(s) at issue in this document sold by TI to Customer on an annual basis.

MECHANICAL DATA

PWP (R-PDSO-G20)

PowerPAD™ PLASTIC SMALL OUTLINE

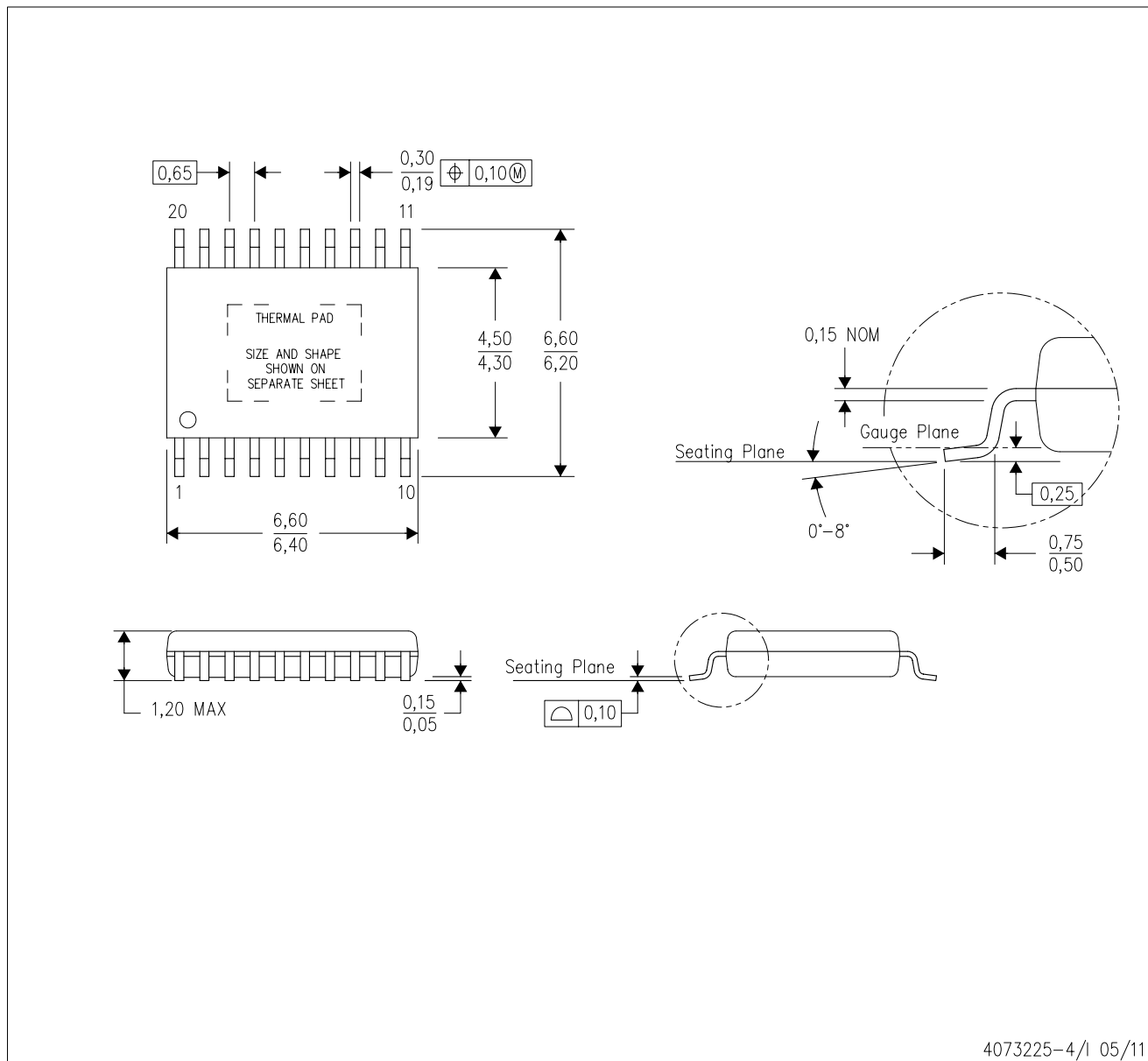

4073225-4/1 05/11

- NOTES:
- All linear dimensions are in millimeters.
 - This drawing is subject to change without notice.
 - Body dimensions do not include mold flash or protrusions. Mold flash and protrusion shall not exceed 0.15 per side.
 - This package is designed to be soldered to a thermal pad on the board. Refer to Technical Brief, PowerPad Thermally Enhanced Package, Texas Instruments Literature No. SLMA002 for information regarding recommended board layout. This document is available at www.ti.com <<http://www.ti.com>>.
 - See the additional figure in the Product Data Sheet for details regarding the exposed thermal pad features and dimensions.
 - Falls within JEDEC MO-153

PowerPAD is a trademark of Texas Instruments.

重要声明和免责声明

TI 均以“原样”提供技术性及其可靠性数据（包括数据表）、设计资源（包括参考设计）、应用或其他设计建议、网络工具、安全信息和其他资源，不保证其中不含任何瑕疵，且不做任何明示或暗示的担保，包括但不限于对适销性、适合某特定用途或不侵犯任何第三方知识产权的暗示担保。

所述资源可供专业开发人员应用TI 产品进行设计使用。您将对以下行为独自承担全部责任：(1) 针对您的应用选择合适的TI 产品；(2) 设计、验证并测试您的应用；(3) 确保您的应用满足相应标准以及任何其他安全、安保或其他要求。所述资源如有变更，恕不另行通知。TI 对您使用所述资源的授权仅限于开发资源所涉及TI 产品的相关应用。除此之外不得复制或展示所述资源，也不提供其它TI 或任何第三方的知识产权授权许可。如因使用所述资源而产生任何索赔、赔偿、成本、损失及债务等，TI 对此概不负责，并且您须赔偿由此对TI 及其代表造成的损害。

TI 所提供产品均受TI 的销售条款 (<http://www.ti.com.cn/zh-cn/legal/termsofsale.html>) 以及ti.com.cn上或随附TI产品提供的其他可适用条款的约束。TI提供所述资源并不扩展或以其他方式更改TI 针对TI 产品所发布的可适用的担保范围或担保免责声明。

邮寄地址：上海市浦东新区世纪大道 1568 号中建大厦 32 楼，邮政编码：200122

Copyright © 2020 德州仪器半导体技术（上海）有限公司