

## INA217 Low-Noise, Low-Distortion Instrumentation Amplifier Replacement for SSM2017

### 1 Features

- Low Noise: 1.3 nV/M $\sqrt{\text{Hz}}$  at 1 kHz
- Low THD+N: 0.004% at 1 kHz, G = 100
- Wide Bandwidth: 800 kHz at G = 100
- Wide Supply Range:  $\pm 4.5$  V to  $\pm 18$  V
- High CMR: > 100 dB
- Gain Set With External Resistor
- DIP-8 and SOL-16 Widebody Packages

### 2 Applications

- Professional Microphone Preamps
- Moving-coil Transducer Amplifiers
- Differential Receivers
- Bridge Transducer Amplifiers

### 3 Description

The INA217 device is a low-noise, low-distortion, monolithic instrumentation amplifier. Current-feedback circuitry allows the INA217 device to achieve wide bandwidth and excellent dynamic response over a wide range of gain. The INA217 device is ideal for low-level audio signals such as balanced low-impedance microphones. Many industrial, instrumentation, and medical applications also benefit from its low noise and wide bandwidth.

Unique distortion cancellation circuitry reduces distortion to extremely low levels, even in high gain. The INA217 device provides near-theoretical noise performance for 200- $\Omega$  source impedance. The INA217 device features differential input, low noise, and low distortion that provides superior performance in professional microphone amplifier applications.

The INA217 device features wide supply voltage, excellent output voltage swing, and high output current drive, making it an optimal candidate for use in high-level audio stages.

The INA217 device is available in the same DIP-8 and SOL-16 wide body packages and pinouts as the SSM2017. For a smaller package, see the INA163 device in SO-14 narrow. The INA217 device is specified over the temperature range of  $-40^{\circ}\text{C}$  to  $85^{\circ}\text{C}$ .

#### Device Information<sup>(1)</sup>

| PART NUMBER | PACKAGE   | BODY SIZE (NOM)    |
|-------------|-----------|--------------------|
| INA217      | SOIC (16) | 10.30 mm x 7.50 mm |
|             | PDIP (8)  | 9.81 mm x 6.35 mm  |

(1) For all available packages, see the orderable addendum at the end of the data sheet.



**INA217**

SBOS247C – JUNE 2002 – REVISED NOVEMBER 2015

www.ti.com

**Simplified Schematic**

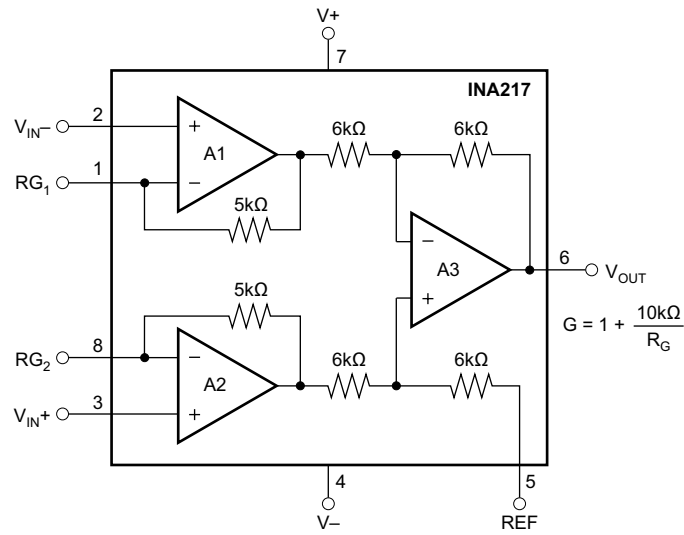

## Table of Contents

|   |           |  |           |
|---|-----------|--|-----------|
| <b>1 Features</b> .....                                       | <b>1</b>  | 7.4 Device Functional Modes.....                                 | <b>12</b> |
| <b>2 Applications</b> .....                                   | <b>1</b>  | <b>8 Application and Implementation</b> .....                    | <b>13</b> |
| <b>3 Description</b> .....                                    | <b>1</b>  | 8.1 Application Information.....                                 | <b>13</b> |
| <b>4 Revision History</b> .....                               | <b>3</b>  | 8.2 Typical Application .....                                    | <b>13</b> |
| <b>5 Pin Configuration and Functions</b> .....                | <b>4</b>  | <b>9 Power Supply Recommendations</b> .....                      | <b>14</b> |
| <b>6 Specifications</b> .....                                 | <b>5</b>  | <b>10 Layout</b> .....   | <b>15</b> |
| 6.1 Absolute Maximum Ratings .....                            | <b>5</b>  | 10.1 Layout Guidelines .....                                     | <b>15</b> |
| 6.2 ESD Ratings .....   | <b>5</b>  | 10.2 Layout Example .....  | <b>15</b> |
| 6.3 Recommended Operating Conditions.....                     | <b>5</b>  | <b>11 Device and Documentation Support</b> .....                 | <b>16</b> |
| 6.4 Thermal Information .....                                 | <b>5</b>  | 11.1 Device Support.....   | <b>16</b> |
| 6.5 Electrical Characteristics: $V_S = \pm 15\text{ V}$ ..... | <b>6</b>  | 11.2 Documentation Support .....                                 | <b>16</b> |
| 6.6 Typical Characteristics.....                              | <b>8</b>  | 11.3 Community Resources.....                                    | <b>16</b> |
| <b>7 Detailed Description</b> .....                           | <b>10</b> | 11.4 Trademarks .....  | <b>17</b> |
| 7.1 Overview .....  | <b>10</b> | 11.5 Electrostatic Discharge Caution.....                        | <b>17</b> |
| 7.2 Functional Block Diagram .....                            | <b>10</b> | 11.6 Glossary .....  | <b>17</b> |
| 7.3 Feature Description.....                                  | <b>10</b> | <b>12 Mechanical, Packaging, and Orderable Information</b> ..... | <b>17</b> |

## 4 Revision History

NOTE: Page numbers for previous revisions may differ from page numbers in the current version.

### Changes from Revision B (February 2005) to Revision C

Page

- Added *ESD Ratings* table, *Feature Description* section, *Device Functional Modes*, *Application and Implementation* section, *Power Supply Recommendations* section, *Layout* section, *Device and Documentation Support* section, and *Mechanical, Packaging, and Orderable Information* section .....

1

## 5 Pin Configuration and Functions

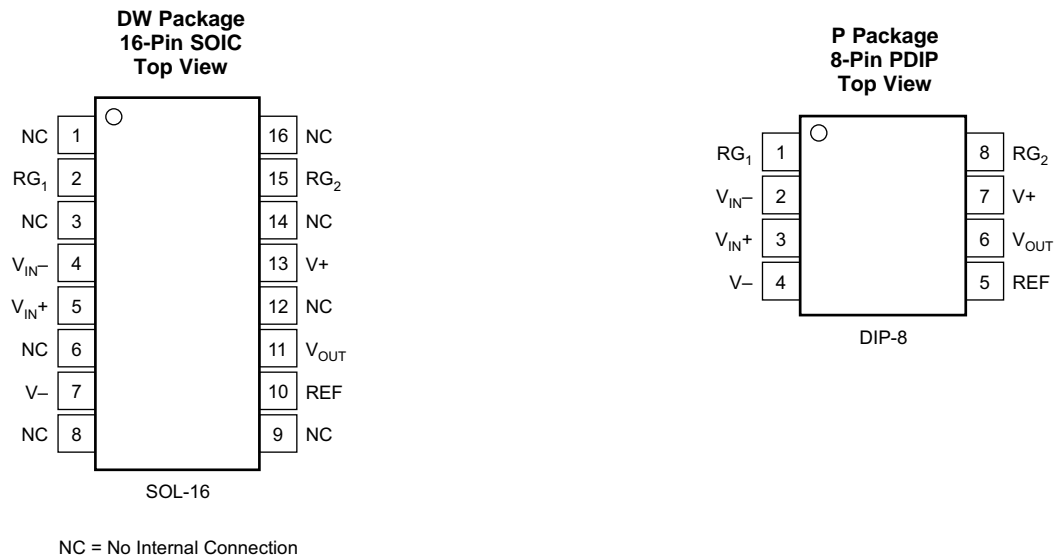

### Pin Functions

| PIN         |     | I/O | DESCRIPTION  |
|-------------|-----|-----|--|
| NAME        | NO. |     |  |
| <b>PDIP</b> |     |     |  |
| NC          | 1   | —   | No internal connection   |
| RG1         | 2   | I   | Gain setting pin, for gains greater than one, connect an external resistor between pins 2 and 15 |
| NC          | 3   | —   | No internal connection   |
| VIN-        | 4   | I   | Inverting input  |
| VIN+        | 5   | I   | Non-inverting input  |
| NC          | 6   | —   | No internal connection   |
| V-          | 7   | I   | negative power supply  |
| NC          | 8   | —   | No internal connection   |
| NC          | 9   | —   | No internal connection   |
| REF         | 10  | I   | Reference input  |
| VOUT        | 11  | O   | Output   |
| NC          | 12  | —   | No internal connection   |
| V+          | 13  | I   | Positive power supply  |
| NC          | 14  | —   | No internal connection   |
| RG2         | 15  | I   | Gain setting pin, for gains greater than one, connect an external resistor between pins 2 and 15 |
| NC          | 16  | —   | No internal connection   |
| <b>SOIC</b> |     |     |  |
| RG1         | 1   | I   | Gain setting pin, for gains greater than one, connect an external resistor between pins 1 and 8  |
| VIN-        | 2   | I   | Inverting input  |
| VIN+        | 3   | I   | Non-inverting input  |
| V-          | 4   | I   | negative power supply  |
| REF         | 5   | I   | Reference input  |
| VOUT        | 6   | O   | Output   |
| V+          | 7   | I   | Positive power supply  |
| RG2         | 8   | I   | Gain setting pin, for gains greater than one, connect an external resistor between pins 2 and 15 |

## 6 Specifications

### 6.1 Absolute Maximum Ratings

over operating free-air temperature range (unless otherwise noted) <sup>(1)</sup>

|                                     |                        | MIN        | MAX        | UNIT |
|-------------------------------------|------------------------|------------|------------|------|
| V+ to V–                            | Supply voltage         | ±18        |            | V    |
| Signal input terminals              | Voltage <sup>(2)</sup> | (V–) – 0.5 | (V+) + 0.5 | V    |
|                                     | Current <sup>(2)</sup> | 10         |            | mA   |
| Output short circuit <sup>(3)</sup> |                        | Continuous |            |      |
| Operating temperature               |                        | –55        | 125        | °C   |
| Junction temperature                |                        | 300        |            | °C   |
| T <sub>stg</sub>                    | Storage temperature    | –55        | 150        | °C   |

- (1) Stresses beyond those listed under *Absolute Maximum Ratings* may cause permanent damage to the device. These are stress ratings only, which do not imply functional operation of the device at these or any other conditions beyond those indicated under *Recommended Operating Conditions*. Exposure to absolute-maximum-rated conditions for extended periods may affect device reliability.
- (2) Input terminals are diode-clamped to the power-supply rails. Input signals that can swing more than 0.5 V beyond the supply rails should be current limited to 10 mA or less.
- (3) Short-circuit to ground, one amplifier per package.

### 6.2 ESD Ratings

|                    |                         | VALUE | UNIT |
|--------------------|-------------------------|-------|------|
| V <sub>(ESD)</sub> | Electrostatic discharge | ±4000 | V    |
|                    |                         | ±1000 |      |

- (1) JEDEC document JEP155 states that 500-V HBM allows safe manufacturing with a standard ESD control process.
- (2) JEDEC document JEP157 states that 250-V CDM allows safe manufacturing with a standard ESD control process.

### 6.3 Recommended Operating Conditions

over operating free-air temperature range (unless otherwise noted)

|                |                     | MIN  | NOM | MAX | UNIT |
|----------------|---------------------|------|-----|-----|------|
| V+ to V–       | Supply voltage      | ±4.5 | ±15 | ±18 | V    |
| T <sub>A</sub> | Ambient Temperature | –40  | 25  | 85  | °C   |

### 6.4 Thermal Information

| THERMAL METRIC <sup>(1)</sup> | INA217                                       |          | UNIT |      |
|-------------------------------|--|----------|------|------|
|                               | DW (SOIC)                                    | P (PDIP) |      |      |
|                               | 16 PINS                                      | 8 PINS   |      |      |
| R <sub>θJA</sub>              | Junction-to-ambient thermal resistance       | 64.3     | 46.2 | °C/W |
| R <sub>θJC(top)</sub>         | Junction-to-case (top) thermal resistance    | 24.9     | 34.5 | °C/W |
| R <sub>θJB</sub>              | Junction-to-board thermal resistance         | 29.4     | 23.5 | °C/W |
| Ψ <sub>JT</sub>               | Junction-to-top characterization parameter   | 3.3      | 11.7 | °C/W |
| Ψ <sub>JB</sub>               | Junction-to-board characterization parameter | 28.8     | 23.3 | °C/W |
| R <sub>θJC(bot)</sub>         | Junction-to-case (bottom) thermal resistance | N/A      | N/A  | °C/W |

- (1) For more information about traditional and new thermal metrics, see the *Semiconductor and IC Package Thermal Metrics* application report, [SPRA953](#).

## 6.5 Electrical Characteristics: $V_S = \pm 15\text{ V}$

 $T_A = 25^\circ\text{C}$ ,  $R_L = 2\text{ k}\Omega$ ,  $V_S = \pm 15\text{ V}$ , unless otherwise noted.

| PARAMETER                                 |                       | TEST CONDITIONS  | $T_A = 25^\circ\text{C}$ |                |     | UNIT                         |
|---|-----------------------|--|--------------------------|----------------|-----|------------------------------|
|   |                       |  | MIN                      | TYP            | MAX |                              |
| <b>GAIN EQUATION<sup>(1)</sup></b>        |                       |  | $G = 1 + 10k/R_G$        |                |     |                              |
| Range                                     |                       |  | 1 to 10000               |                |     | V/V                          |
| Gain Error                                | G = 1                 |  | $\pm 0.1\%$              | $\pm 0.25\%$   |     |                              |
|   | G = 10                |  | $\pm 0.2\%$              | $\pm 0.7\%$    |     |                              |
|   | G = 100               |  | $\pm 0.2\%$              |                |     |                              |
|   | G = 1000              |  | $\pm 0.5\%$              |                |     |                              |
| <b>GAIN TEMPERATURE DRIFT COEFFICIENT</b> |                       |  |                          |                |     |                              |
|   | G = 1                 | $T_A = -40^\circ\text{C}$ to $85^\circ\text{C}$                  | $\pm 3$                  | $\pm 10$       |     | ppm/ $^\circ\text{C}$        |
|   | G > 10                | $T_A = -40^\circ\text{C}$ to $85^\circ\text{C}$                  | $\pm 40$                 | $\pm 100$      |     | ppm/ $^\circ\text{C}$        |
| Nonlinearity                              | G = 1                 |  | $\pm 0.0003$             |                |     | % of FS                      |
|   | G = 100               |  | $\pm 0.0006$             |                |     | % of FS                      |
| <b>INPUT STAGE NOISE</b>                  |                       |  |                          |                |     |                              |
| Voltage Noise                             | $f_O = 1\text{ kHz}$  | $R_{\text{SOURCE}} = 0\ \Omega$                                  | 1.3                      |                |     | nV/ $\sqrt{\text{Hz}}$       |
|   | $f_O = 100\text{ Hz}$ |  | 1.5                      |                |     | nV/ $\sqrt{\text{Hz}}$       |
|   | $f_O = 10\text{ Hz}$  |  | 3.5                      |                |     | nV/ $\sqrt{\text{Hz}}$       |
| Current Noise, $f_O = 1\text{ kHz}$       |                       |  | 0.8                      |                |     | pA/ $\sqrt{\text{Hz}}$       |
| <b>OUTPUT STAGE NOISE</b>                 |                       |  |                          |                |     |                              |
| Voltage Noise, $f_O = 1\text{ kHz}$       |                       |  | 90                       |                |     | nV/ $\sqrt{\text{Hz}}$       |
| <b>INPUT OFFSET VOLTAGE</b>               |                       |  |                          |                |     |                              |
| Input Offset Voltage                      |                       | $V_{\text{CM}} = V_{\text{OUT}} = 0\text{ V}$                    | $50 + 2000/G$            | $250 + 5000/G$ |     | $\mu\text{V}$                |
| vs Temperature                            |                       | $T_A = -40^\circ\text{C}$ to $85^\circ\text{C}$                  | $1 + 20/G$               |                |     | $\mu\text{V}/^\circ\text{C}$ |
| vs Power Supply                           |                       | $V_S = \pm 4.5\text{ V}$ to $\pm 18\text{ V}$                    | $1 + 50/G$               | $3 + 200/G$    |     | $\mu\text{V}/\text{V}$       |
| <b>INPUT VOLTAGE RANGE</b>                |                       |  |                          |                |     |                              |
| Common-Mode Voltage Range                 |                       | $V_{\text{IN}+} - V_{\text{IN}-} = 0\text{ V}$                   | $(V+) - 4$               | $(V+) - 3$     |     | V                            |
|   |                       | $V_{\text{IN}+} - V_{\text{IN}-} = 0\text{ V}$                   | $(V-) + 4$               | $(V-) + 3$     |     | V                            |
| Common-Mode Rejection                     | G = 1                 | $V_{\text{CM}} = \pm 11\text{ V}$ , $R_{\text{SRC}} = 0\ \Omega$ | 70                       | 80             |     | dB                           |
|   | G = 100               |  | 100                      | 116            |     | dB                           |
| <b>INPUT BIAS CURRENT</b>                 |                       |  |                          |                |     |                              |
| Initial Bias Current                      |                       |  | 2                        | 12             |     | $\mu\text{A}$                |
| vs Temperature                            |                       | $T_A = -40^\circ\text{C}$ to $85^\circ\text{C}$                  | 10                       |                |     | nA/ $^\circ\text{C}$         |
| Initial Offset Current                    |                       |  | 0.1                      | 1              |     | $\mu\text{A}$                |
| vs Temperature                            |                       | $T_A = -40^\circ\text{C}$ to $85^\circ\text{C}$                  | 0.5                      |                |     | nA/ $^\circ\text{C}$         |
| <b>INPUT IMPEDANCE</b>                    |                       |  |                          |                |     |                              |
|   |                       | Differential   | $60\ \parallel\ 2$       |                |     | M $\Omega$ $\parallel$ pF    |
|   |                       | Common-Mode  | $60\ \parallel\ 2$       |                |     | M $\Omega$ $\parallel$ pF    |
| <b>DYNAMIC RESPONSE</b>                   |                       |  |                          |                |     |                              |
| Bandwidth, Small Signal, $-3\text{d B}$   |                       |  |                          |                |     |                              |
| G = 1                                     |                       |  | 3.4                      |                |     | MHz                          |
| G = 100                                   |                       |  | 800                      |                |     | kHz                          |
| Slew Rate                                 |                       |  | 15                       |                |     | V/ $\mu\text{s}$             |
| THD+Noise, $f = 1\text{ kHz}$             |                       | G = 100  | 0.004%                   |                |     |                              |
| Settling Time                             | 0.1%                  | G = 100, 10V Step  | 2                        |                |     | $\mu\text{s}$                |
|   | 0.01%                 | G = 100, 10V Step  | 3.5                      |                |     | $\mu\text{s}$                |
| Overload Recovery                         |                       | 50% Overdrive  | 1                        |                |     | $\mu\text{s}$                |

 (1) Gain accuracy is a function of external  $R_G$ .

**Electrical Characteristics:  $V_S = \pm 15\text{ V}$  (continued)**
 $T_A = 25^\circ\text{C}$ ,  $R_L = 2\text{ k}\Omega$ ,  $V_S = \pm 15\text{ V}$ , unless otherwise noted.

| PARAMETER                  | TEST CONDITIONS      | $T_A = 25^\circ\text{C}$ |                          |          | UNIT             |
|----------------------------|----------------------|--------------------------|--------------------------|----------|------------------|
|                            |                      | MIN                      | TYP                      | MAX      |                  |
| <b>OUTPUT</b>              |                      |                          |                          |          |                  |
| Voltage                    | $R_L$ to GND         | (V+) – 2<br>(V-) + 2     | (V+) – 1.8<br>(V-) + 1.8 |          | V<br>V           |
| Load Capacitance Stability |                      |                          | 1000                     |          | pF               |
| Short Circuit Current      | Continuous-to-Common |                          | $\pm 60$                 |          | mA               |
| <b>POWER SUPPLY</b>        |                      |                          |                          |          |                  |
| Rated Voltage              |                      |                          | $\pm 15$                 |          | V                |
| Voltage Range              |                      | $\pm 4.5$                |                          | $\pm 18$ | V                |
| Current, Quiescent         | $I_O = 0\text{ mA}$  |                          | $\pm 10$                 | $\pm 12$ | mA               |
| <b>TEMPERATURE RANGE</b>   |                      |                          |                          |          |                  |
| Specification              |                      | –40                      |                          | 85       | $^\circ\text{C}$ |
| Operating                  |                      | –40                      |                          | 125      | $^\circ\text{C}$ |

### 6.6 Typical Characteristics

At  $T_A = 25^\circ\text{C}$ ,  $V_S = \pm 15\text{ V}$ ,  $R_L = 2\text{ k}\Omega$ , unless otherwise noted.

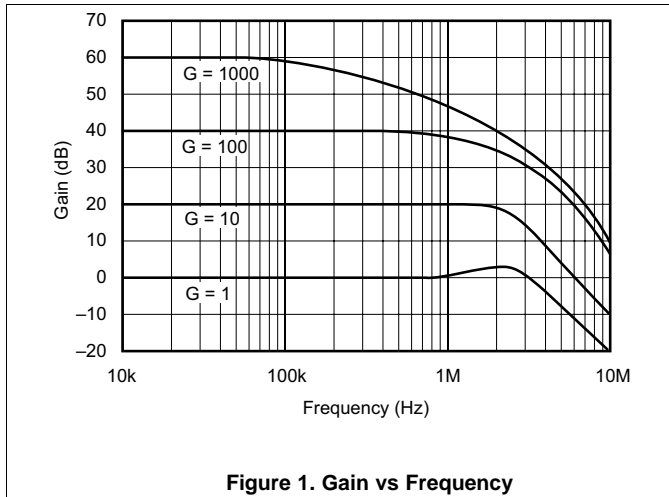

Figure 1. Gain vs Frequency

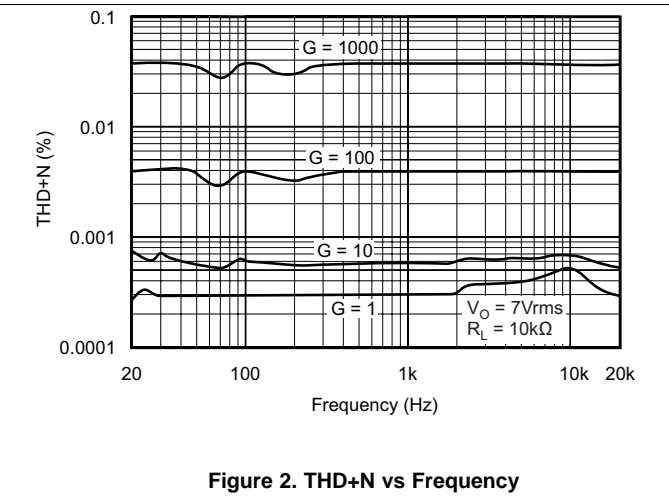

Figure 2. THD+N vs Frequency

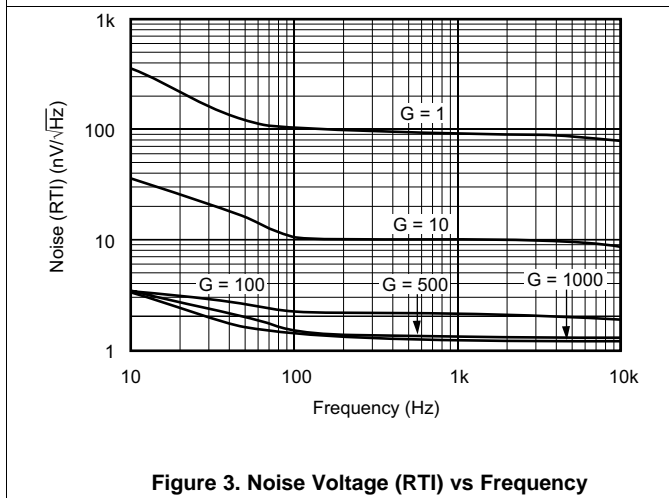

Figure 3. Noise Voltage (RTI) vs Frequency

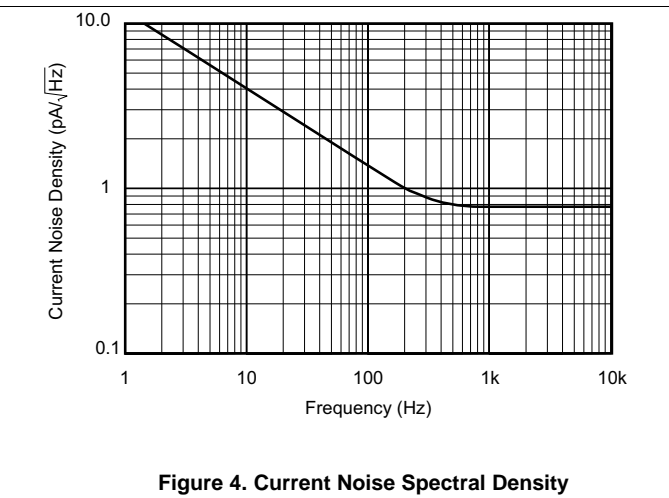

Figure 4. Current Noise Spectral Density

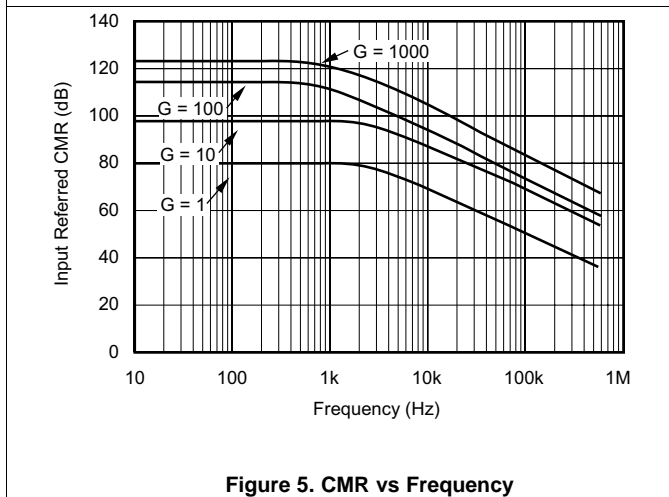

Figure 5. CMR vs Frequency

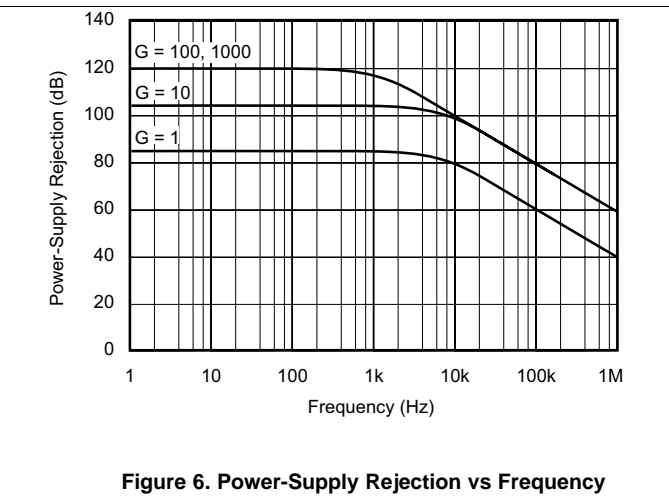
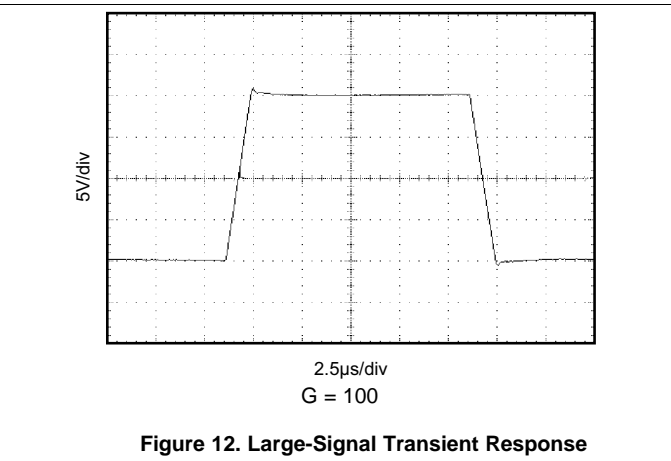
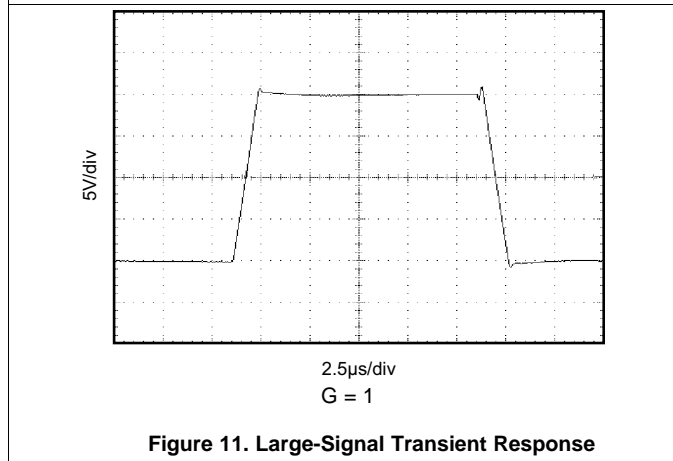
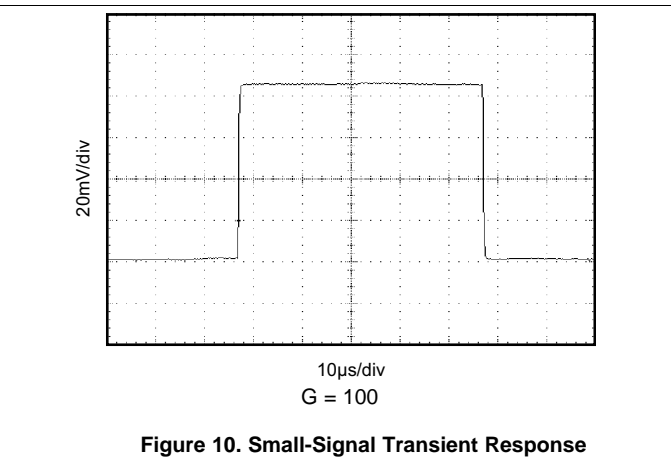
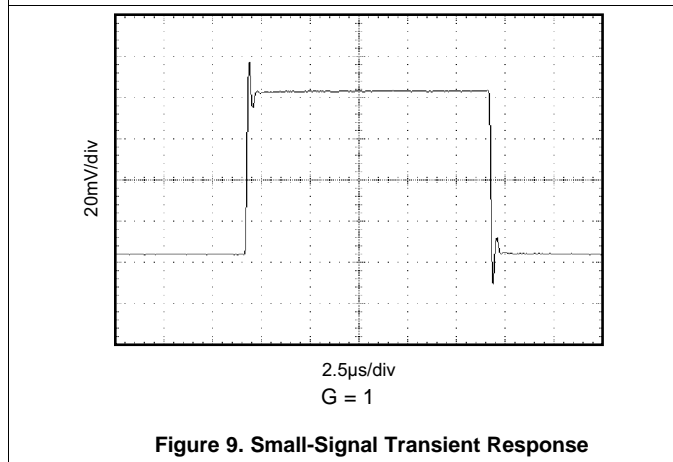
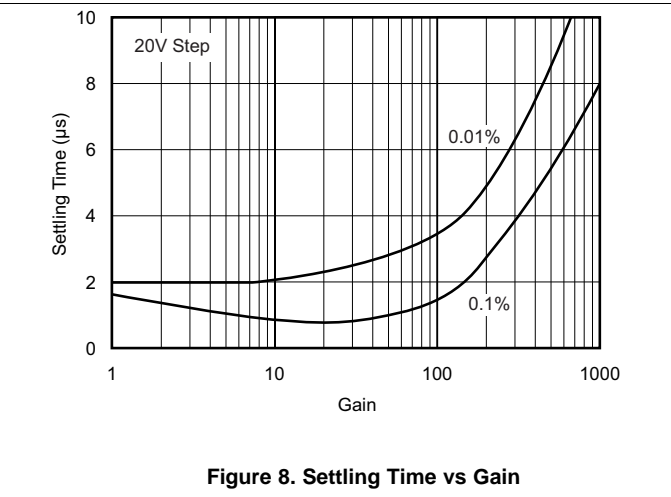
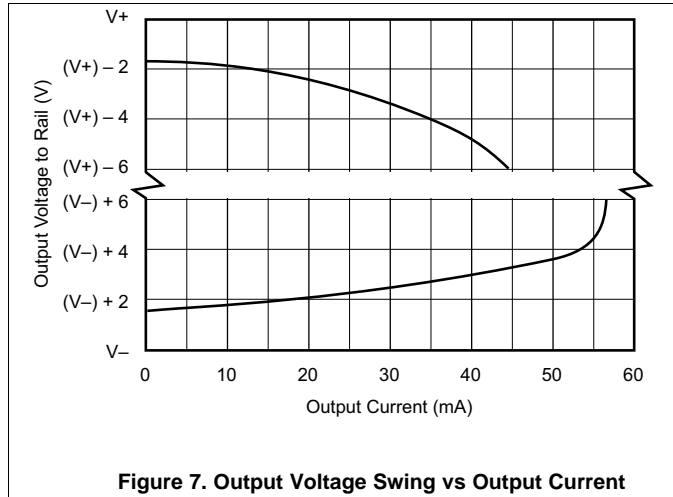

Figure 6. Power-Supply Rejection vs Frequency

**Typical Characteristics (continued)**

At  $T_A = 25^\circ\text{C}$ ,  $V_S = \pm 15\text{ V}$ ,  $R_L = 2\text{ k}\Omega$ , unless otherwise noted.



## 7 Detailed Description

### 7.1 Overview

The INA217 is a classical three-amp instrumentation amplifier designed for audio applications. Featuring low noise and low distortion the INA217 is ideally suited for amplifying low level audio signals. With a wide supply voltage, wide output voltage swing, and high output current drive the INA217 is also ideally suited for processing high level audio signals. Specified from  $-40^{\circ}\text{C}$  to  $85^{\circ}\text{C}$  the INA217 is well suited for industrial applications.

### 7.2 Functional Block Diagram

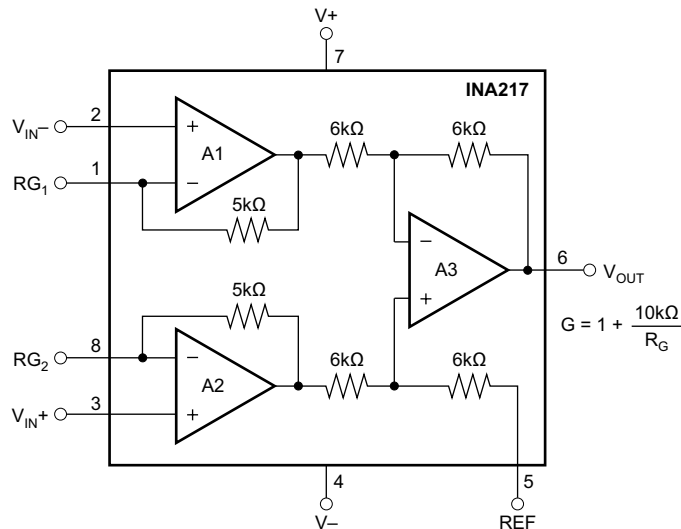

### 7.3 Feature Description

#### 7.3.1 Basic Connections

Figure 13 shows the basic connections required for operation. Power supplies should be bypassed with  $0.1\text{-}\mu\text{F}$  tantalum capacitors near the device pins. The output Reference (pin 5) should be a low-impedance connection. Resistance of a few  $\Omega$ s in series with this connection will degrade the common-mode rejection of the INA217.

Feature Description (continued)

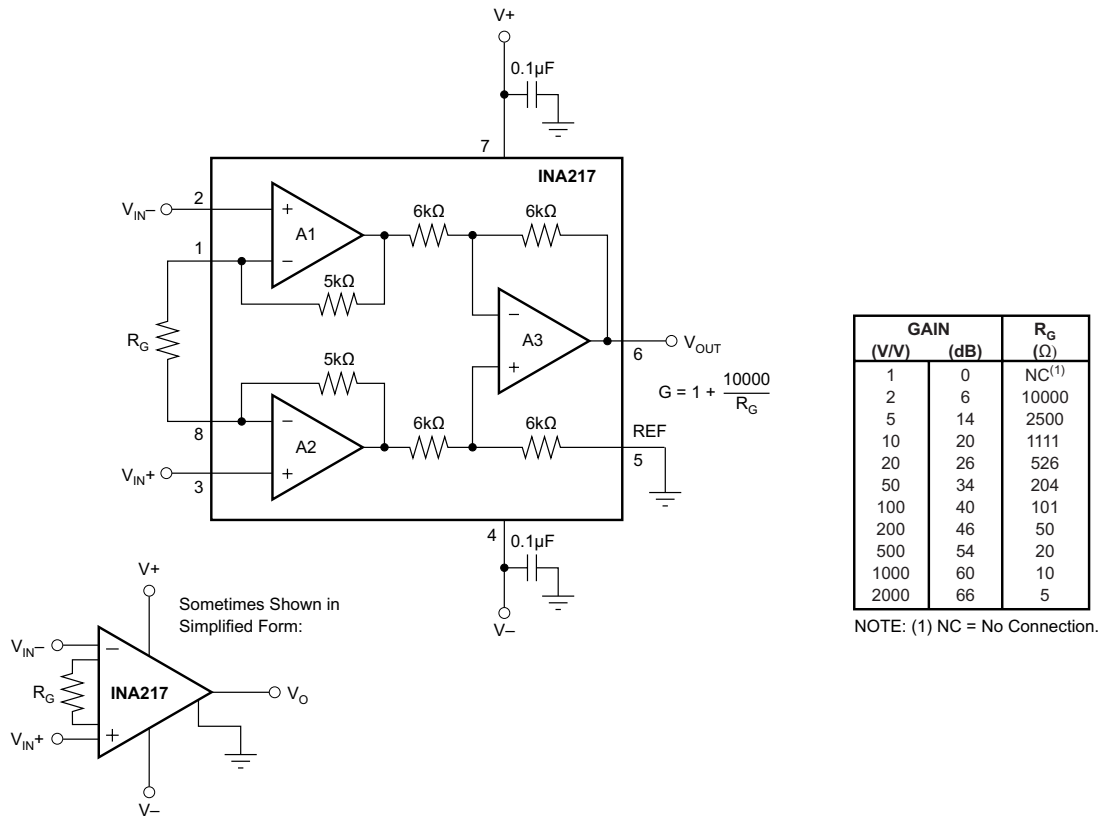

Figure 13. Basic Circuit Connections

7.3.2 Gain-Set Resistor

Gain is set with an external resistor, R<sub>G</sub>, as shown in Figure 13. The two internal 5-kΩ feedback resistors are laser-trimmed to 5-kΩ within approximately ±0.2%. Equation 1 shows the gain equation for the INA217.

$$G = 1 + \frac{10\,000}{R_G} \tag{1}$$

The temperature coefficient of the internal 5-kΩ resistors is approximately ±25 ppm/°C. Accuracy and TCR of the external R<sub>G</sub> will also contribute to gain error and temperature drift. These effects can be inferred from the gain equation. Make a short, direct connection to the gain set resistor, R<sub>G</sub>. Avoid running output signals near these sensitive input nodes.

7.3.3 Noise Performance

The INA217 provides very low noise with low-source impedance. Its 1.3-nV/M√Hz voltage noise delivers near-theoretical noise performance with a source impedance of 200 Ω. The input stage design used to achieve this low noise results in relatively high input bias current and input bias current noise. As a result, the INA217 may not provide the best noise performance with a source impedance greater than 10 kΩ. For source impedance greater than 10 kΩ, other instrumentation amplifiers may provide improved noise performance.

7.3.4 Input Considerations

Very low source impedance (less than 10 Ω) can cause the INA217 to oscillate. This depends on circuit layout, signal source, and input cable characteristics. An input network consisting of a small inductor and resistor, as shown in Figure 14, can greatly reduce any tendency to oscillate. This is especially useful if a variety of input sources are to be connected to the INA217. Although not shown in other figures, this network can be used as needed with all applications shown.

## Feature Description (continued)

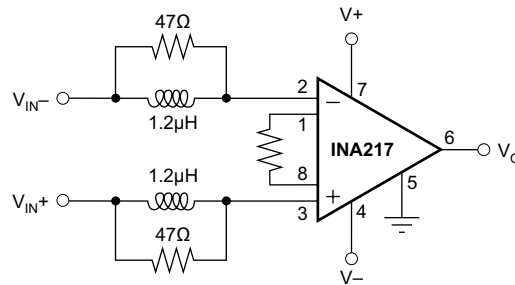

**Figure 14. Input Stabilization Network**

### 7.3.5 Offset Voltage Trim

A variable voltage applied to pin 5, as shown in [Figure 15](#), can be used to adjust the output offset voltage. A voltage applied to pin 5 is summed with the output signal. An operational amplifier connected as a buffer is used to provide a low impedance at pin 5 to assure good common-mode rejection.

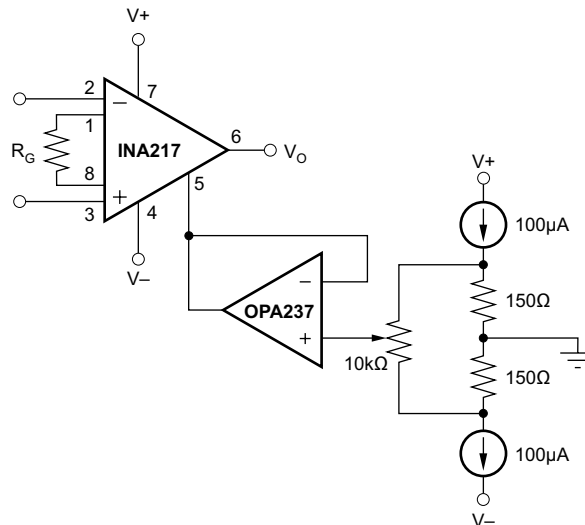

**Figure 15. Offset Voltage Adjustment Circuit**

## 7.4 Device Functional Modes

The INA217 has a single functional mode of operation. The mode is operational when the power supply voltage exceeds  $\pm 4.5$  V. The maximum power supply voltage is  $\pm 18$  V. The INA217 is specified over the temperature range from  $-40^{\circ}\text{C}$  to  $85^{\circ}\text{C}$  and is operational to  $125^{\circ}\text{C}$ .

## 8 Application and Implementation

### NOTE

Information in the following applications sections is not part of the TI component specification, and TI does not warrant its accuracy or completeness. TI's customers are responsible for determining suitability of components for their purposes. Customers should validate and test their design implementation to confirm system functionality.

### 8.1 Application Information

The INA217 is used in professional audio equipment such as professional microphone preamps, moving-coil transducer amplifiers, differential receivers, and bridge transducer amplifiers.

### 8.2 Typical Application

Figure 16 shows a typical circuit for a professional microphone input amplifier.

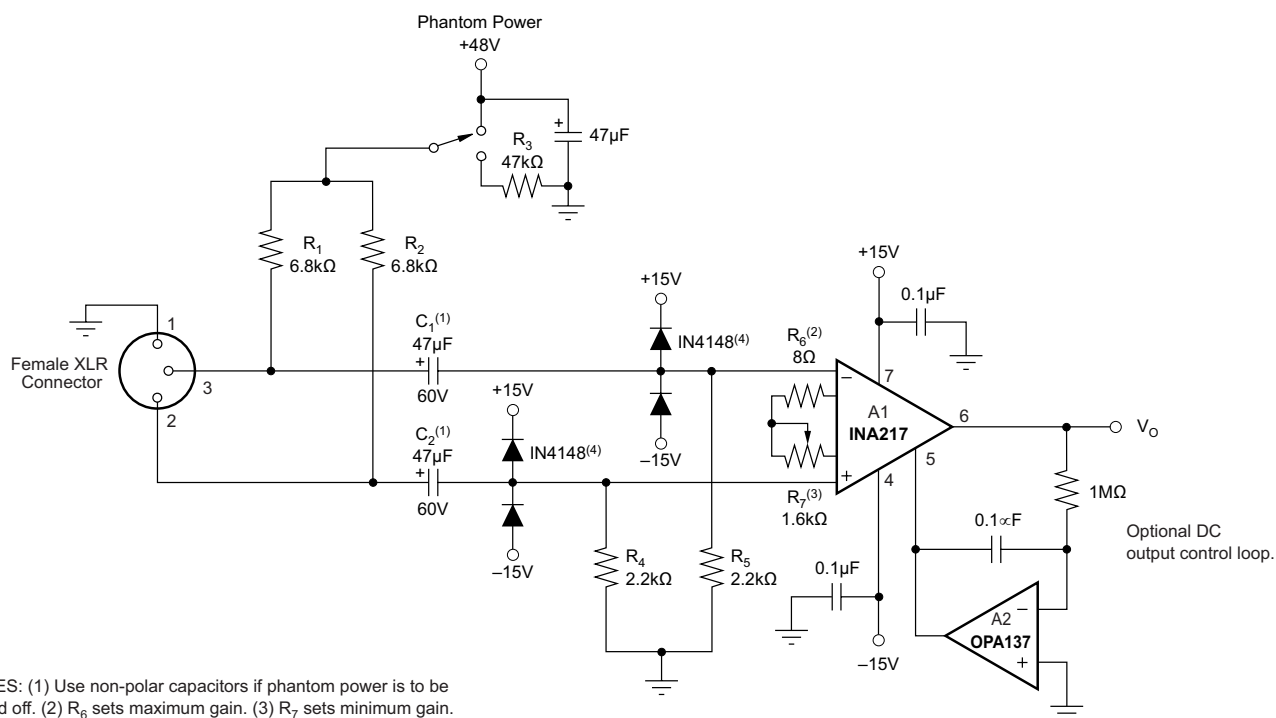

NOTES: (1) Use non-polar capacitors if phantom power is to be turned off. (2)  $R_6$  sets maximum gain. (3)  $R_7$  sets minimum gain. (4) Optional IN4148 prevents damage due to ESD and hot-plugging.

Figure 16. Phantom-Powered Microphone Preamplifier

#### 8.2.1 Design Requirements

- 48-V, Phantom powered, remotely located microphone
- Circuitry operates from  $\pm 15$ -V power supplies
- Low distortion and noise over the audio frequency band
- Gain range from to 20 db to 60 db

#### 8.2.2 Detailed Design Procedure

$R_1$  and  $R_2$  provide a current path for conventional 48-V phantom power source for a remotely located microphone. An optional switch allows phantom power to be disabled.  $C_1$  and  $C_2$  block the phantom power voltage from the INA217 input circuitry. Non-polarized capacitors should be used for  $C_1$  and  $C_2$  if phantom power is to be disabled. For additional input protection against ESD and hot-plugging, four IN4148 diodes may be connected from the input to supply lines.

## Typical Application (continued)

$R_4$  and  $R_5$  provide a path for input bias current of the INA217. Input offset current (typically 100 nA) creates a DC differential input voltage that will produce an output offset voltage. This is generally the dominant source of output offset voltage in this application. With a maximum gain of 1000 (60 dB), the output offset voltage can be several volts. This may be entirely acceptable if the output is AC-coupled into the subsequent stage. An alternate technique is shown in [Figure 16](#). An inexpensive FET-input operational amplifier in a feedback loop drives the DC output voltage to 0 V. A2 is not in the audio signal path and does not affect signal quality.

Gain is set with a variable resistor,  $R_7$ , in series with  $R_6$ .  $R_6$  determines the maximum gain. The total resistance,  $R_6 + R_7$ , determines the lowest gain. A special reverse-log taper potentiometer for  $R_7$  can be used to create a linear change (in dB) with rotation.

### 8.2.3 Application Curve

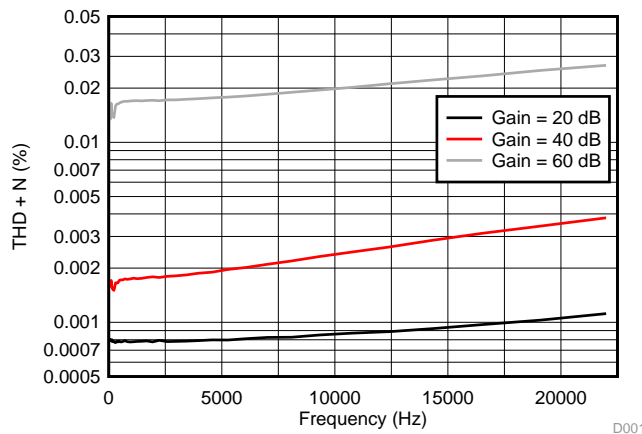

Figure 17. THD + Noise for the Phantom Powered Microphone Circuit

## 9 Power Supply Recommendations

The INA217 is specified for operation from  $\pm 4.5$  V to  $\pm 18$  V; many specifications apply from  $-40^\circ\text{C}$  to  $85^\circ\text{C}$ . Parameters that can exhibit significant variance with regard to operating voltage or temperature are presented in the [Typical Characteristics](#).

## 10 Layout

### 10.1 Layout Guidelines

For best operational performance of the device, use good PCB layout practices, including:

- Noise can propagate into analog circuitry through the power pins of the circuit as a whole and op amp itself. Bypass capacitors are used to reduce the coupled noise by providing low-impedance power sources local to the analog circuitry.
  - Connect low-ESR, 0.1- $\mu$ F ceramic bypass capacitors between each supply pin and ground, placed as close to the device as possible. A single bypass capacitor from V+ to ground is applicable for single-supply applications.
- Separate grounding for analog and digital portions of circuitry is one of the simplest and most-effective methods of noise suppression. One or more layers on multilayer PCBs are usually devoted to ground planes. A ground plane helps distribute heat and reduces EMI noise pickup. Make sure to physically separate digital and analog grounds paying attention to the flow of the ground current. For more detailed information, see *Circuit Board Layout Techniques*, [SLOA089](#).
- To reduce parasitic coupling, run the input traces as far away from the supply or output traces as possible. If these traces cannot be kept separate, crossing the sensitive trace perpendicular is much better as opposed to in parallel with the noisy trace.
- Place the external components as close to the device as possible.
- Keep the length of input traces as short as possible. Always remember that the input traces are the most sensitive part of the circuit.
- Consider a driven, low-impedance guard ring around the critical traces. A guard ring can significantly reduce leakage currents from nearby traces that are at different potentials.
- TI recommends cleaning the PCB following board assembly for best performance.
- Any precision integrated circuit may experience performance shifts due to moisture ingress into the plastic package. Following any aqueous PCB cleaning process, TI recommends baking the PCB assembly to remove moisture introduced into the device packaging during the cleaning process. A low temperature, post cleaning bake at 85°C for 30 minutes is sufficient for most circumstances.

### 10.2 Layout Example

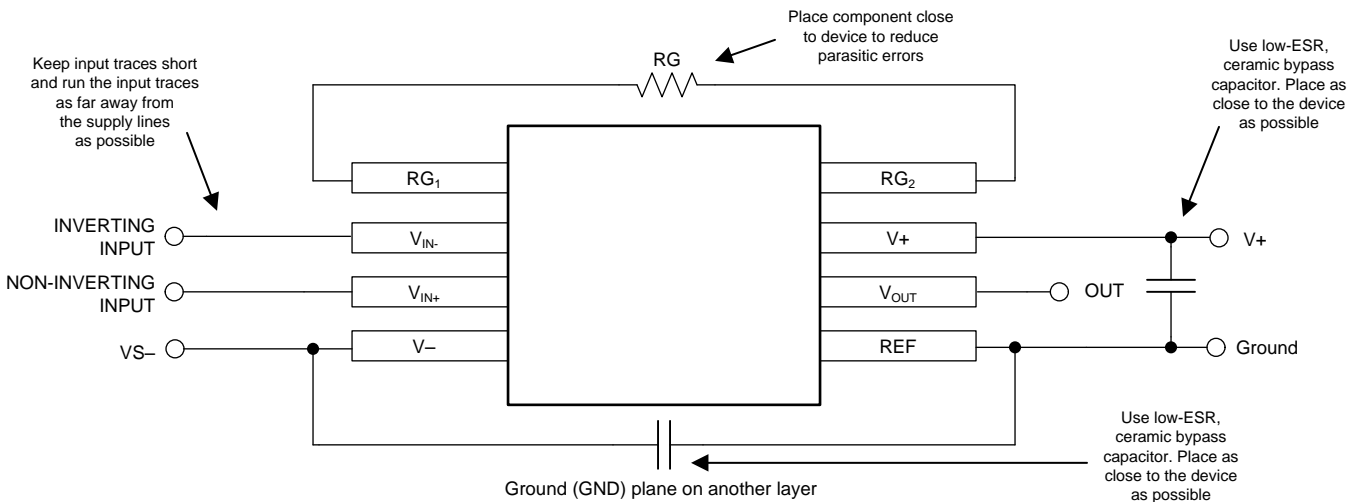

**Figure 18. INA217 Layout Example**

## 11 Device and Documentation Support

### 11.1 Device Support

#### 11.1.1 Development Support

##### 11.1.1.1 TINA-TI™ (Free Software Download)

TINA™ is a simple, powerful, and easy-to-use circuit simulation program based on a SPICE engine. TINA-TI is a free, fully-functional version of the TINA software, preloaded with a library of macro models in addition to a range of both passive and active models. TINA-TI provides all the conventional dc, transient, and frequency domain analysis of SPICE, as well as additional design capabilities.

Available as a [free download](#) from the Analog eLab Design Center, TINA-TI offers extensive post-processing capability that allows users to format results in a variety of ways. Virtual instruments offer the ability to select input waveforms and probe circuit nodes, voltages, and waveforms, creating a dynamic quick-start tool.

#### NOTE

These files require that either the TINA software (from DesignSoft™) or TINA-TI software be installed. Download the free TINA-TI software from the [TINA-TI folder](#).

##### 11.1.1.2 TI Precision Designs

TI Precision Designs are available online at <http://www.ti.com/ww/en/analog/precision-designs/>. TI Precision Designs are analog solutions created by TI's precision analog applications experts and offer the theory of operation, component selection, simulation, complete PCB schematic and layout, bill of materials, and measured performance of many useful circuits.

##### 11.1.1.3 WEBENCH® Filter Designer

[WEBENCH® Filter Designer](#) is a simple, powerful, and easy-to-use active filter design program. The WEBENCH Filter Designer lets you create optimized filter designs using a selection of TI operational amplifiers and passive components from TI's vendor partners.

Available as a web based tool from the WEBENCH® Design Center, [WEBENCH® Filter Designer](#) allows you to design, optimize, and simulate complete multistage active filter solutions within minutes.

### 11.2 Documentation Support

#### 11.2.1 Related Documentation

For related documentation see the following:

- *Circuit Board Layout Techniques*, [SLOA089](#).
- *Shelf-Life Evaluation of Lead-Free Component Finishes*, [SZZA046](#).

### 11.3 Community Resources

The following links connect to TI community resources. Linked contents are provided "AS IS" by the respective contributors. They do not constitute TI specifications and do not necessarily reflect TI's views; see TI's [Terms of Use](#).

**TI E2E™ Online Community** *TI's Engineer-to-Engineer (E2E) Community*. Created to foster collaboration among engineers. At [e2e.ti.com](http://e2e.ti.com), you can ask questions, share knowledge, explore ideas and help solve problems with fellow engineers.

**Design Support** *TI's Design Support* Quickly find helpful E2E forums along with design support tools and contact information for technical support.

## 11.4 Trademarks

TINA-TI, E2E are trademarks of Texas Instruments.  
TINA, DesignSoft are trademarks of DesignSoft, Inc.  
All other trademarks are the property of their respective owners.

## 11.5 Electrostatic Discharge Caution



These devices have limited built-in ESD protection. The leads should be shorted together or the device placed in conductive foam during storage or handling to prevent electrostatic damage to the MOS gates.

## 11.6 Glossary

[SLYZ022](#) — *TI Glossary*.

This glossary lists and explains terms, acronyms, and definitions.

## 12 Mechanical, Packaging, and Orderable Information

The following pages include mechanical, packaging, and orderable information. This information is the most current data available for the designated devices. This data is subject to change without notice and revision of this document. For browser-based versions of this data sheet, refer to the left-hand navigation.

## PACKAGING INFORMATION

| Orderable Device | Status<br>(1) | Package Type | Package Drawing | Pins | Package Qty | Eco Plan<br>(2) | Lead finish/<br>Ball material<br>(6) | MSL Peak Temp<br>(3) | Op Temp (°C) | Device Marking<br>(4/5) | Samples                 |
|------------------|---------------|--------------|-----------------|------|-------------|-----------------|--------------------------------------|----------------------|--------------|-------------------------|-------------------------|
| INA217AIDWR      | ACTIVE        | SOIC         | DW              | 16   | 2000        | RoHS & Green    | NIPDAU                               | Level-3-260C-168 HR  | -40 to 125   | INA217                  | <a href="#">Samples</a> |
| INA217AIDWT      | ACTIVE        | SOIC         | DW              | 16   | 250         | RoHS & Green    | NIPDAU                               | Level-3-260C-168 HR  | -40 to 125   | INA217                  | <a href="#">Samples</a> |
| INA217AIP        | ACTIVE        | PDIP         | P               | 8    | 50          | RoHS & Green    | NIPDAU                               | N / A for Pkg Type   | -40 to 85    | INA217                  | <a href="#">Samples</a> |
| INA217AIPG4      | ACTIVE        | PDIP         | P               | 8    | 50          | RoHS & Green    | NIPDAU                               | N / A for Pkg Type   | -40 to 85    | INA217                  | <a href="#">Samples</a> |

(1) The marketing status values are defined as follows:

**ACTIVE:** Product device recommended for new designs.

**LIFEBUY:** TI has announced that the device will be discontinued, and a lifetime-buy period is in effect.

**NRND:** Not recommended for new designs. Device is in production to support existing customers, but TI does not recommend using this part in a new design.

**PREVIEW:** Device has been announced but is not in production. Samples may or may not be available.

**OBSOLETE:** TI has discontinued the production of the device.

(2) **RoHS:** TI defines "RoHS" to mean semiconductor products that are compliant with the current EU RoHS requirements for all 10 RoHS substances, including the requirement that RoHS substance do not exceed 0.1% by weight in homogeneous materials. Where designed to be soldered at high temperatures, "RoHS" products are suitable for use in specified lead-free processes. TI may reference these types of products as "Pb-Free".

**RoHS Exempt:** TI defines "RoHS Exempt" to mean products that contain lead but are compliant with EU RoHS pursuant to a specific EU RoHS exemption.

**Green:** TI defines "Green" to mean the content of Chlorine (Cl) and Bromine (Br) based flame retardants meet JS709B low halogen requirements of <=1000ppm threshold. Antimony trioxide based flame retardants must also meet the <=1000ppm threshold requirement.

(3) MSL, Peak Temp. - The Moisture Sensitivity Level rating according to the JEDEC industry standard classifications, and peak solder temperature.

(4) There may be additional marking, which relates to the logo, the lot trace code information, or the environmental category on the device.

(5) Multiple Device Markings will be inside parentheses. Only one Device Marking contained in parentheses and separated by a "-" will appear on a device. If a line is indented then it is a continuation of the previous line and the two combined represent the entire Device Marking for that device.

(6) Lead finish/Ball material - Orderable Devices may have multiple material finish options. Finish options are separated by a vertical ruled line. Lead finish/Ball material values may wrap to two lines if the finish value exceeds the maximum column width.

**Important Information and Disclaimer:**The information provided on this page represents TI's knowledge and belief as of the date that it is provided. TI bases its knowledge and belief on information provided by third parties, and makes no representation or warranty as to the accuracy of such information. Efforts are underway to better integrate information from third parties. TI has taken and

continues to take reasonable steps to provide representative and accurate information but may not have conducted destructive testing or chemical analysis on incoming materials and chemicals. TI and TI suppliers consider certain information to be proprietary, and thus CAS numbers and other limited information may not be available for release.

In no event shall TI's liability arising out of such information exceed the total purchase price of the TI part(s) at issue in this document sold by TI to Customer on an annual basis.

**TAPE AND REEL INFORMATION**

**QUADRANT ASSIGNMENTS FOR PIN 1 ORIENTATION IN TAPE**

\*All dimensions are nominal

| Device      | Package Type | Package Drawing | Pins | SPQ  | Reel Diameter (mm) | Reel Width W1 (mm) | A0 (mm) | B0 (mm) | K0 (mm) | P1 (mm) | W (mm) | Pin1 Quadrant |
|-------------|--------------|-----------------|------|------|--------------------|--------------------|---------|---------|---------|---------|--------|---------------|
| INA217AIDWR | SOIC         | DW              | 16   | 2000 | 330.0              | 16.4               | 10.75   | 10.7    | 2.7     | 12.0    | 16.0   | Q1            |
| INA217AIDWT | SOIC         | DW              | 16   | 250  | 180.0              | 16.4               | 10.75   | 10.7    | 2.7     | 12.0    | 16.0   | Q1            |

**TAPE AND REEL BOX DIMENSIONS**

\*All dimensions are nominal

| Device      | Package Type | Package Drawing | Pins | SPQ  | Length (mm) | Width (mm) | Height (mm) |
|-------------|--------------|-----------------|------|------|-------------|------------|-------------|
| INA217AIDWR | SOIC         | DW              | 16   | 2000 | 853.0       | 449.0      | 35.0        |
| INA217AIDWT | SOIC         | DW              | 16   | 250  | 210.0       | 185.0      | 35.0        |

**TUBE**

\*All dimensions are nominal

| Device      | Package Name | Package Type | Pins | SPQ | L (mm) | W (mm) | T (μm) | B (mm) |
|-------------|--------------|--------------|------|-----|--------|--------|--------|--------|
| INA217AIP   | P            | PDIP         | 8    | 50  | 506    | 13.97  | 11230  | 4.32   |
| INA217AIPG4 | P            | PDIP         | 8    | 50  | 506    | 13.97  | 11230  | 4.32   |

## GENERIC PACKAGE VIEW

**DW 16**

**SOIC - 2.65 mm max height**

7.5 x 10.3, 1.27 mm pitch

SMALL OUTLINE INTEGRATED CIRCUIT

This image is a representation of the package family, actual package may vary.  
Refer to the product data sheet for package details.



4224780/A



DW0016A

# PACKAGE OUTLINE

SOIC - 2.65 mm max height

SOIC

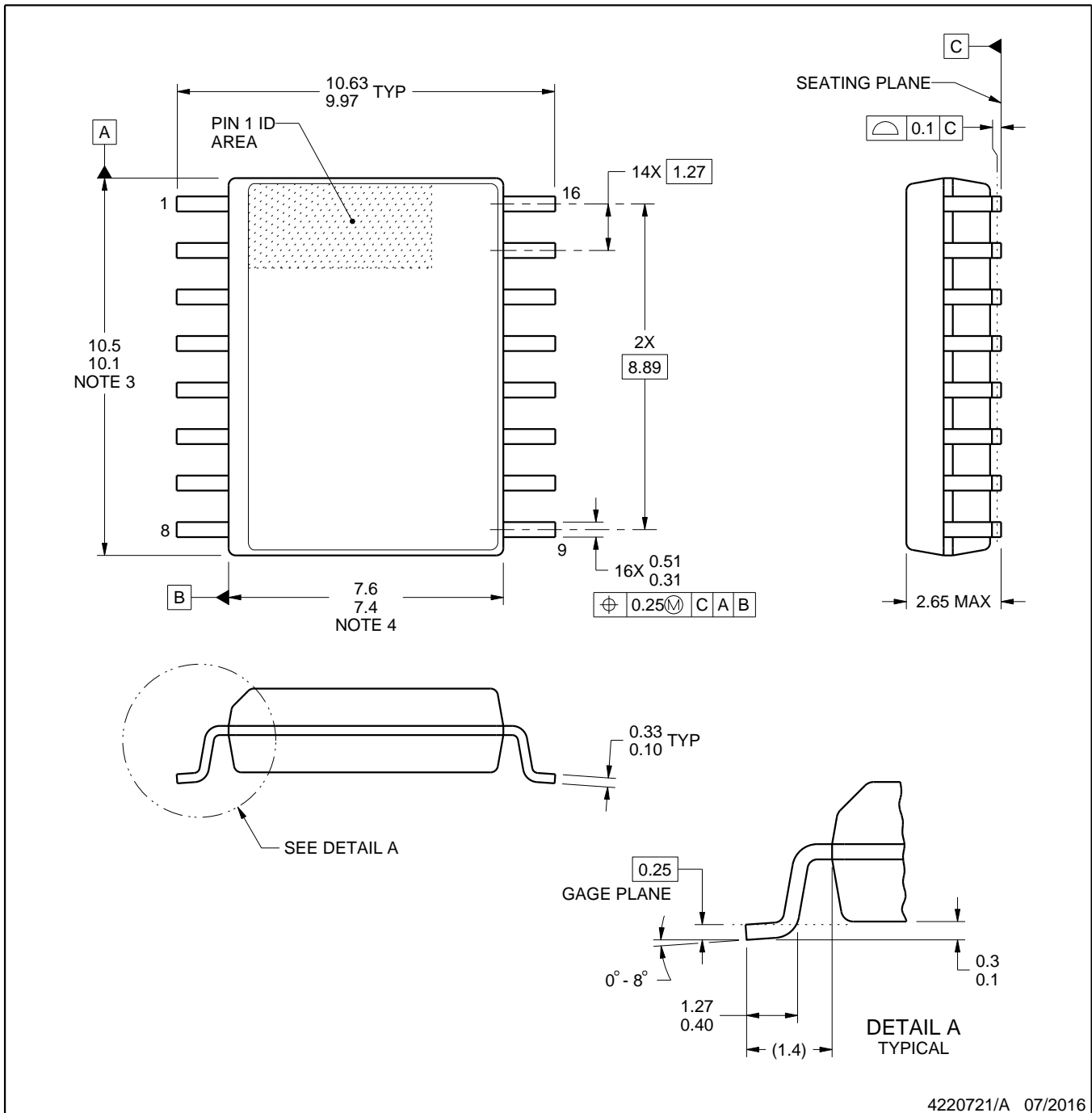

4220721/A 07/2016

NOTES:

1. All linear dimensions are in millimeters. Dimensions in parenthesis are for reference only. Dimensioning and tolerancing per ASME Y14.5M.
2. This drawing is subject to change without notice.
3. This dimension does not include mold flash, protrusions, or gate burrs. Mold flash, protrusions, or gate burrs shall not exceed 0.15 mm, per side.
4. This dimension does not include interlead flash. Interlead flash shall not exceed 0.25 mm, per side.
5. Reference JEDEC registration MS-013.

# EXAMPLE BOARD LAYOUT

DW0016A

SOIC - 2.65 mm max height

SOIC



LAND PATTERN EXAMPLE  
SCALE:7X



SOLDER MASK DETAILS

4220721/A 07/2016

NOTES: (continued)

6. Publication IPC-7351 may have alternate designs.

7. Solder mask tolerances between and around signal pads can vary based on board fabrication site.

# EXAMPLE STENCIL DESIGN

DW0016A

SOIC - 2.65 mm max height

SOIC



SOLDER PASTE EXAMPLE  
BASED ON 0.125 mm THICK STENCIL  
SCALE:7X

4220721/A 07/2016

NOTES: (continued)

8. Laser cutting apertures with trapezoidal walls and rounded corners may offer better paste release. IPC-7525 may have alternate design recommendations.
9. Board assembly site may have different recommendations for stencil design.

P (R-PDIP-T8)

PLASTIC DUAL-IN-LINE PACKAGE



- NOTES:
- A. All linear dimensions are in inches (millimeters).
  - B. This drawing is subject to change without notice.
  - C. Falls within JEDEC MS-001 variation BA.

## IMPORTANT NOTICE AND DISCLAIMER

TI PROVIDES TECHNICAL AND RELIABILITY DATA (INCLUDING DATA SHEETS), DESIGN RESOURCES (INCLUDING REFERENCE DESIGNS), APPLICATION OR OTHER DESIGN ADVICE, WEB TOOLS, SAFETY INFORMATION, AND OTHER RESOURCES "AS IS" AND WITH ALL FAULTS, AND DISCLAIMS ALL WARRANTIES, EXPRESS AND IMPLIED, INCLUDING WITHOUT LIMITATION ANY IMPLIED WARRANTIES OF MERCHANTABILITY, FITNESS FOR A PARTICULAR PURPOSE OR NON-INFRINGEMENT OF THIRD PARTY INTELLECTUAL PROPERTY RIGHTS.

These resources are intended for skilled developers designing with TI products. You are solely responsible for (1) selecting the appropriate TI products for your application, (2) designing, validating and testing your application, and (3) ensuring your application meets applicable standards, and any other safety, security, regulatory or other requirements.

These resources are subject to change without notice. TI grants you permission to use these resources only for development of an application that uses the TI products described in the resource. Other reproduction and display of these resources is prohibited. No license is granted to any other TI intellectual property right or to any third party intellectual property right. TI disclaims responsibility for, and you will fully indemnify TI and its representatives against, any claims, damages, costs, losses, and liabilities arising out of your use of these resources.

TI's products are provided subject to [TI's Terms of Sale](#) or other applicable terms available either on [ti.com](http://ti.com) or provided in conjunction with such TI products. TI's provision of these resources does not expand or otherwise alter TI's applicable warranties or warranty disclaimers for TI products.

TI objects to and rejects any additional or different terms you may have proposed.

Mailing Address: Texas Instruments, Post Office Box 655303, Dallas, Texas 75265  
Copyright © 2022, Texas Instruments Incorporated