

**General-Purpose 3 V to 5.5 V  
16-Bit 22-KSPS DSP CODEC  
TLV320AIC10**

*Data Manual*

# Contents

<i>Section</i>	<i>Title</i>	<i>Page</i>
<b>1</b>	<b>Introduction</b>	<b>1-1</b>
1.1	Features	1-1
1.2	Functional Block Diagram	1-3
1.3	Terminal Assignments	1-4
1.4	Ordering Information	1-5
1.5	Terminal Functions	1-6
1.6	Definitions and Terminology	1-7
1.7	Register Functional Summary	1-8
<b>2</b>	<b>Functional Description</b>	<b>2-1</b>
2.1	Device Functions	2-1
2.1.1	Operating Frequencies	2-1
2.1.2	ADC Signal Channel	2-1
2.1.3	DAC Signal Channel	2-2
2.1.4	MIC Input	2-4
2.1.5	Antialiasing Filter	2-4
2.1.6	Sigma-Delta ADC	2-4
2.1.7	Decimation Filter	2-4
2.1.8	Sigma-Delta DAC	2-4
2.1.9	Interpolation Filter	2-4
2.1.10	Analog and Digital Loopback	2-5
2.1.11	FIR Overflow Flag	2-5
2.1.12	FIR Bypass Mode	2-5
2.1.13	Low-Power Mode	2-5
2.1.14	Event-Monitor Mode	2-5
2.2	Reset and Power-Down Functions	2-6
2.2.1	Software and Hardware Reset	2-6
2.2.2	Software and Hardware Power Down	2-6
2.3	Clock Source	2-7
2.4	Data Out (DOUT)	2-7
2.4.1	Data Out, Master Mode	2-7
2.4.2	Data Out, Slave Mode	2-7
2.5	Data In (DIN)	2-7
2.6	FC (Hardware Secondary Communication Request)	2-7
2.7	Frame-Sync Function for TLV320AIC10	2-7
2.7.1	Frame-Sync (FS) Function—Continuous-Transfer Mode (Master Only)	2-9
2.7.2	Frame-Sync (FS) Function—Fast-Transfer Mode (Slave Only)	2-9

2.7.3	Frame-Sync (FS) Function—Master Mode	2–9
2.7.4	Frame-Sync (FS) Function—Slave Mode	2–10
2.7.5	Frame-Sync Delayed (FSD) Function, Cascade Mode	2–10
2.8	Multiplexed Analog Input and Output	2–11
2.8.1	Multiplexed Analog Input	2–11
2.8.2	Analog Output	2–12
2.8.3	Single-Ended Analog Input	2–12
2.8.4	Single-Ended Analog Output	2–12
<b>3</b>	<b>Serial Communications</b>	<b>3–1</b>
3.1	Primary Serial Communication	3–1
3.2	Secondary Serial Communication	3–2
3.2.1	Register Programming	3–3
3.2.2	Hardware Secondary Serial Communication Request	3–4
3.2.3	Software Secondary Serial Communication Request	3–5
3.3	Direct Configuration Mode	3–5
3.4	Continuous Data Transfer Mode	3–7
3.5	DIN and DOUT Data Format	3–8
3.5.1	Primary Serial Communication DIN and DOUT Data Format	3–8
3.5.2	Secondary Serial Communication DIN and DOUT Data Format	3–8
3.5.3	Direct Configuration DCSI Data Format	3–8
<b>4</b>	<b>Specifications</b>	<b>4–1</b>
4.1	Absolute Maximum Ratings Over Operating Free-Air Temperature Range	4–1
4.2	Recommended Operating Conditions	4–1
4.3	Electrical Characteristics Over Recommended Operating Free-Air Temperature Range, $AV_{DD} = 5\text{ V}/3.3\text{ V}$ , $DV_{DD} = 5\text{ V}/3.3\text{ V}$	4–1
4.3.1	Digital Inputs and Outputs, $F_s = 8\text{ kHz}$ , Output Not Loaded	4–1
4.3.2	ADC Path Filter, $F_s = 8\text{ kHz}$	4–2
4.3.3	ADC Dynamic Performance, $F_s = 8\text{ kHz}$	4–2
4.3.4	ADC Channel Characteristics	4–3
4.3.5	DAC Path Filter, $F_s = 8\text{ kHz}$	4–3
4.3.6	DAC Dynamic Performance	4–3
4.3.7	DAC Channel Characteristics	4–4
4.3.8	Op-Amp Interface (A1, A3, A4)	4–4
4.3.9	Power-Supply Rejection	4–4
4.3.10	Power Supply	4–5
4.4	Timing Requirements	4–5
4.4.1	Master Mode Timing Requirements	4–5

<b>5</b>	<b>Parameter Measurement Information</b> .....	<b>5-1</b>
<b>6</b>	<b>Mechanical Information</b> .....	<b>6-1</b>
	<b>Appendix A—Register Set</b> .....	<b>A-1</b>

## List of Illustrations

<i>Figure</i>	<i>Title</i>	<i>Page</i>
2-1	Timing Sequence of ADC Channel (Primary Communication Only) .....	2-1
2-2	Timing Sequence of ADC Channel (Primary and Secondary Communication) .....	2-2
2-3	Timing Sequence of DAC Channel (Primary Communication Only) .....	2-3
2-4	Timing Sequence of DAC Channel (Primary and Secondary Communication) .....	2-3
2-5	Typical Microphone Interface .....	2-4
2-6	Event Monitor Mode Timing .....	2-5
2-7	Internal Power-Down Logic .....	2-6
2-8	Timing Diagram for the FS Pulse Mode (M1M0 = 00) .....	2-8
2-9	Timing Diagram for the SPI_CP0 Mode (M1M0 = 01) .....	2-8
2-10	Timing Diagram for the SPI_CP1 Mode (M1M0 = 10) .....	2-8
2-11	Timing Diagram for the FS Frame Mode (M1M0 = 11) .....	2-9
2-12	Master Device Frame-Sync Signal With Primary and Secondary Communication ( No Slaves) .....	2-9
2-13	Master Device's FS Output to DSP and FSD Output to the Slave .....	2-10
2-14	Cascade Mode Connection (to DSP Interface) .....	2-10
2-15	Master-Slave Frame-Sync Timing .....	2-11
2-16	INP and INM Internal Self-Biased ( $AV_{DD}/2$ ) Circuit .....	2-11
2-17	Differential Output Drive (Ground-Referenced) .....	2-12
2-18	Single-Ended Input .....	2-12
2-19	Single-Ended Output .....	2-12
3-1	Primary Serial Communication Timing .....	3-1
3-2	Hardware and Software Secondary Communication Request .....	3-2
3-3	Device 3/Register 1 Read Operation Timing Diagram .....	3-3
3-4	Device 3/Register 1 Write Operation Timing Diagram .....	3-4
3-5	FS Output When Hardware Secondary Serial Communication Is Requested Only Once (No Slave) .....	3-4
3-6	Output When Hardware Secondary Serial Communication Is Requested (Three Slaves) .....	3-5
3-7	FS Output During Software Secondary Serial Communication Request (No Slave) .....	3-5
3-8	Direct Configuration .....	3-6

3-9	Direct Configuration Mode Timing .....	3-7
3-10	Continuous Data Transfer Mode Timing .....	3-7
3-11	Primary Communication DIN and DOUT Data Format .....	3-8
3-12	Secondary Communication DIN and DOUT Data Format .....	3-8
3-13	Direct Communication DCSI Data Format .....	3-8
5-1	FC, FS and FSD Timing .....	5-1
5-2	Serial Communication Timing .....	5-1
5-3	FFT-ADC Channel .....	5-2
5-4	FFT-ADC Channel .....	5-2
5-5	FFT-DAC Channel .....	5-3
5-6	FFT-DAC Channel .....	5-3
5-7	FFT-ADC Channel .....	5-4
5-8	FFT-ADC Channel .....	5-4
5-9	FFT-DAC Channel .....	5-5
5-10	FFT-DAC Channel .....	5-5

## List of Tables

<i>Table</i>	<i>Title</i>	<i>Page</i>
2-1	Serial Interface Modes .....	2-8
3-1	Least Significant Bit Control Function .....	3-2

# 1 Introduction

The TLV320AIC10 provides high resolution signal conversion from digital-to-analog (D/A) and from analog-to-digital (A/D) using oversampling sigma-delta technology. It allows 2-to-1 MUX inputs with built-in antialiasing filter and amplification for general-purpose applications such as telephone hybrid interface, electret microphone preamp, etc. Both IN and AUX inputs accept normal analog signals. This device consists of a pair of 16-bit synchronous serial conversion paths (one for each direction), and includes an interpolation filter before the DAC and a decimation filter after the ADC. The FIR filters can be bypassed to offer flexibility and power savings. Other overhead functions provide on-chip include timing (programmable sample rate, continuous data transfer, and FIR bypass) and control (programmable-gain amplifier, communication protocol, etc.). The sigma-delta architecture produces high-resolution analog-to-digital and digital-to-analog conversion at low system cost.

The TLV320AIC10 design enhances communication with the DSP. The continuous data transfer mode fully supports TI's DSP autobuffering (ABU) to reduce DSP interrupt service overhead. The automatic cascading detection (ACD) makes cascade programming simple and supports a cascade operation of one master and up to seven slaves. The direct-configuration mode for host interface uses a single-wire serial port to directly program internal registers without interference from the data conversion serial port, or without resetting the entire device. The event monitor mode allows the DSP to monitor external events like phone off-hook ring detection.

In the lower-power mode, the TLV320AIC10 converts data at a sampling rate of 8 KSPS consuming only 39 mW.

The programmable functions of this device are configured through a serial interface that can be gluelessly interfaced to any DSP that accepts 4-wire serial communications, such as the TMS320Cxx. The options include software reset, device power-down, separate control for ADC and DAC turnoff, communications protocol, signal-sampling rate, gain control, and system-test modes, as outlined in Appendix A.

The TLV320AIC10 is particularly suitable for a variety of applications in hands-free car kits, VOIP, cable modem, speech, and the telephony area including low-bit rate, high-quality compression, speech enhancement, recognition, and synthesis. Its low-group delay characteristic makes it suitable for single or multichannel active-control applications.

The TLV320AIC10 is characterized for commercial operation from 0°C to 70°C, and industrial operation from -40°C to 85°C.

## 1.1 Features

- C54xx software driver available
- 16-bit oversampling sigma-delta A/D converter
- 16-bit oversampling sigma-delta D/A converter
- Maximum output conversion rate:
  - 22 ksps with on-chip FIR filter
  - 88 ksps with FIR bypassed
- Voiceband bandwidth in FIR-bypassed mode and final sampling rate at 8 ksps
  - 90-dB SNR/ADC and 87-dB SNR/DAC with DSPs FIR (FIR bypassed at 88 ksps/5 V)
  - 87-dB SNR/ADC and 85-dB SNR/DAC with DSPs FIR (FIR bypassed at 88 ksps/3.3 V)
- On-chip FIR produced 84-dB SNR for ADC and 85-dB SNR for DAC over 11-kHz BW
- Built-in functions including PGA, antialiasing analog filter, and operational amplifiers for general-purpose interface (such as MIC interface and hybrid interface)

- Glueless serial port interface to DSPs (TI TMS320Cxx, SPI, or standard DSPs)
- Automatic cascading detection (ACD) makes cascade programming simple and allows up to 8 devices to be connected in cascade.
- On-fly reconfiguration modes include secondary-communication mode and direct-configuration mode (host interface).
- Continuous data-transfer mode for use with autobuffering (ABU) to reduce DSP interrupt service overhead
- Event-monitor mode provides external-event control, such as RING/OFF-HOOK detection
- Programmable ADC and DAC conversion rate
- Programmable input and output gain control
- Separate software control for ADC and DAC power-down
- Analog (3-V to 5.5-V) supply operation
- Digital (3-V to 5.5-V) supply operation
- Power dissipation ( $P_D$ ) of 39 mWrms typical for 8-ksps at 3.3 V
- Hardware power-down mode to 0.5 mW
- Internal and external reference voltage ( $V_{ref}$ )
- Differential and single-ended analog input/output
- 2s-complement data format
- Test mode, which includes digital loopback and analog loopback
- 600-ohm output driver

## 1.2 Functional Block Diagram

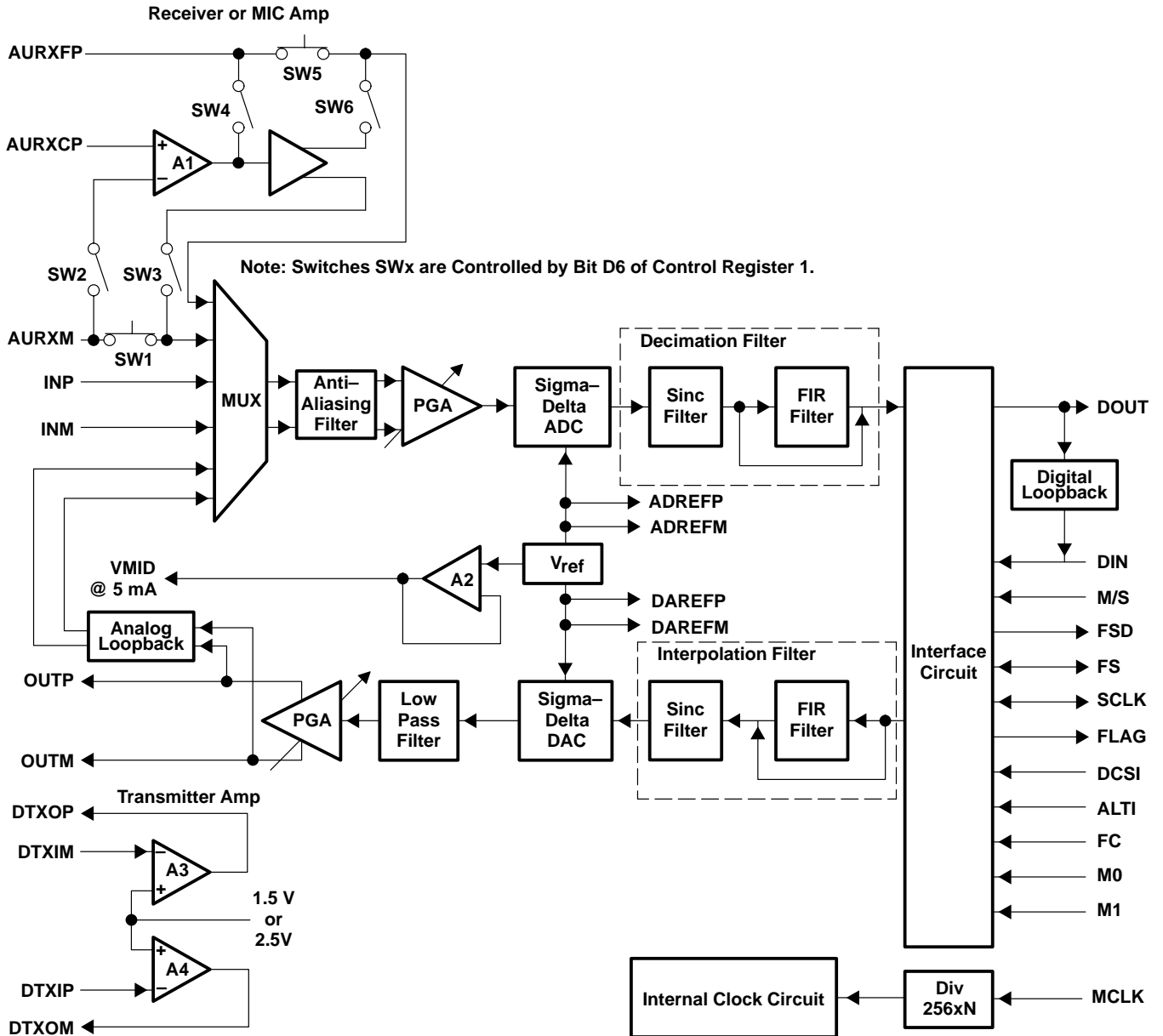

### 1.3 Terminal Assignments

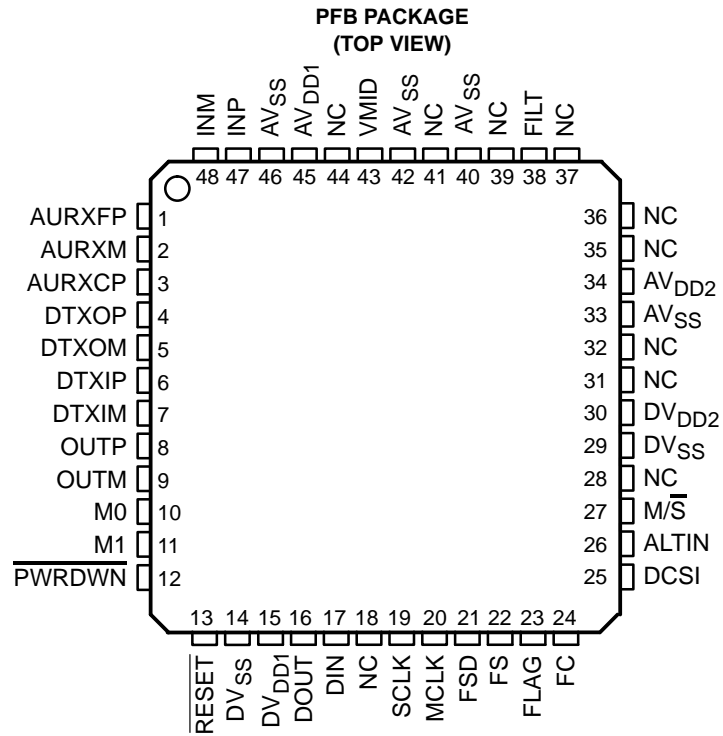

NOTE: All NC pins should be left unconnected.

### 1.3 Terminal Assignments (Continued)

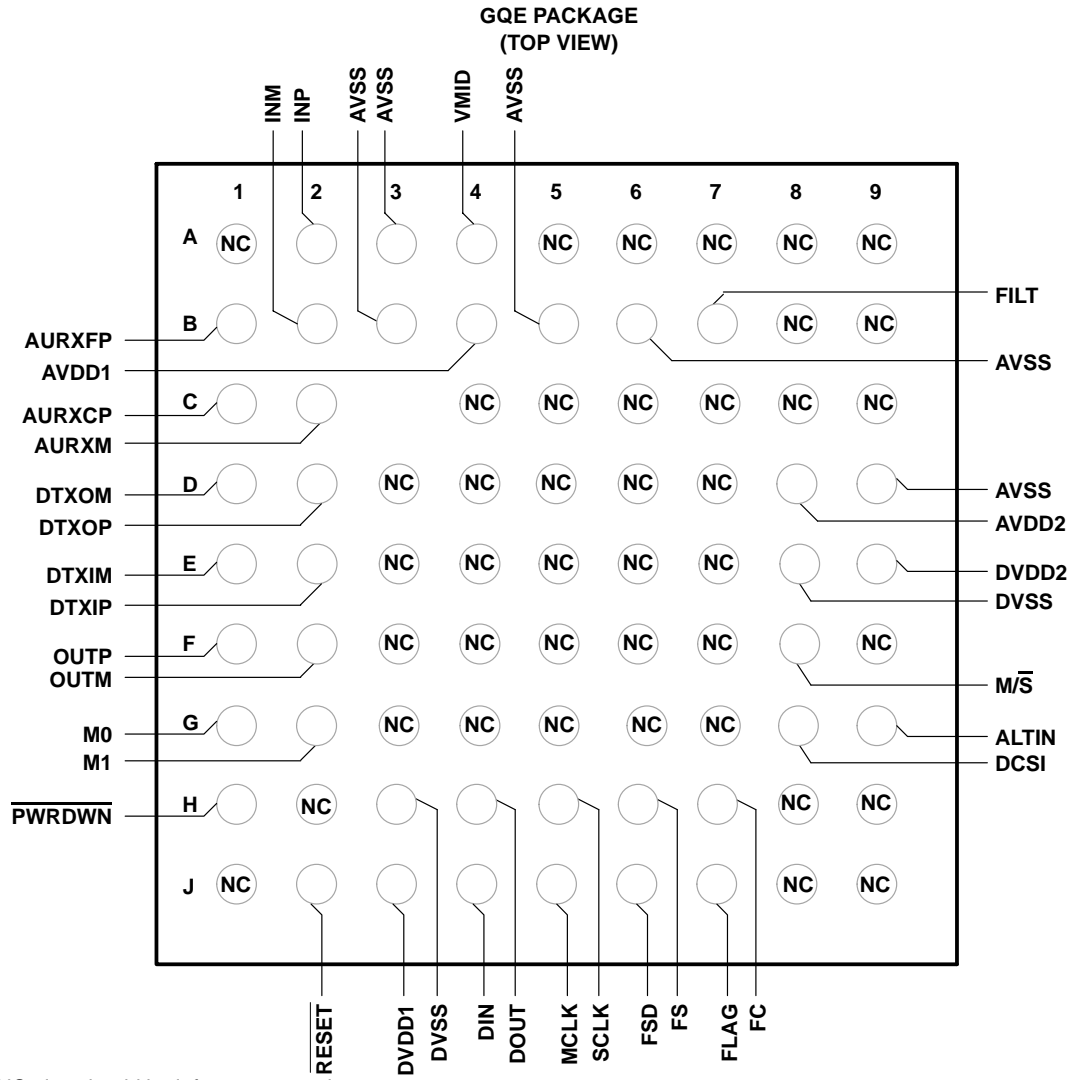

NOTE: All NC pins should be left unconnected.

### 1.4 Ordering Information

T <sub>A</sub>	PACKAGES	
	48-PIN TQFP PFB	80-PIN MicroStar Junior GQE
0°C to 70°C	TLV320AIC10C	TLV320AIC10CGQE
-40°C to 85°C	TLV320AIC10I	TLV320AIC10IGQE

## 1.5 Terminal Functions

TERMINALS			I/O	DESCRIPTION
NAME	NO.			
	PFB	GQE	I/O	
ALTIN	26	G9	I	Serial input in the <i>event monitor</i> mode. Tie this pin to low if not used.
AURXCP	3	C1	I	Receiver-path/GP amplifier noninverting input. It needs to be connected to AV <sub>SS</sub> if not used.
AURXM	2	C2	I	Receiver-path amplifier A1 inverting input, or inverting input to auxiliary analog input. It needs to be connected to AV <sub>SS</sub> if not used. Can also be used for general-purpose amplification.
AURXFP	1	B1	I	Receiver-path amplifier A1 feedback, or noninverting input to auxiliary analog input. It needs to be connected to AV <sub>SS</sub> if not used. Can also be used for general-purpose amplification.
AVDD1	45	B4	I	Analog power supply
AVDD2	34	D8	I	Analog power supply
AVSS	33, 40, 42, 46	A3, B3, B5, B6, D9	I	Analog ground
DCSI	25	G8	I	Direct configuration serial input for directly programming of internal control registers. Tie this pin to high if not used.
DIN	17	J4	I	Data input. DIN receives the DAC input data and register data from the external digital signal processor (DSP), and is synchronized to SCLK and FS. Data is latched at the falling edge of SCLK when FS is low. DIN is at high impedance when FS is not activated.
DOUT	16	H4	O	Data output. DOUT transmits the ADC output bits and registers data, and is synchronized to SCLK and FS. Data is sent out at the rising edge of SCLK when FS is low. DOUT is at high impedance when FS is not activated.
DTXIM	7	E1	I	Transmitter-path amplifier A3 analog inverting input. Can also be used for general-purpose amplification.
DTXIP	6	E2	I	Transmitter-path amplifier A4 analog noninverting input. Can also be used for general-purpose amplification.
DTXOM	5	D1	O	Transmitter path amplifier A4 feedback for negative output. Can also be used for general-purpose amplification.
DTXOP	4	D2	O	Transmitter path amplifier A3 feedback for positive output. Can also be used for negative output.
DVDD1	15	J3	I	Digital power supply
DVDD2	30	E9	I	Digital power supply
DVSS	14, 29	E8, H3	I	Digital ground
FC	24	H7	I	Hardware request for secondary communication. Tie this pin to low if not used.
FILT	38	B7	O	Bandgap filter. FILT is provided for decoupling of the bandgap reference, and provides 2.5 V. The optimal capacitor value is 0.1 $\mu$ F (ceramic). This voltage node should be loaded only with a high-impedance dc load.
FLAG	23	J7	O	Controlled by bit D4 of control register 3. If D4=0 (default), the FLAG pin outputs the communication flag that goes low/high to indicate primary-communication/secondary-communication interval, respectively. If D4=1, the FLAG pin outputs the value of D3.
FS	22	H6	I/O	Frame sync. When FS goes low, DIN begins receiving data bits and DOUT begins transmitting data bits. In master mode, FS is internally generated and is low during data transmission to DIN and from DOUT. In slave mode, FS is externally generated.
FSD	21	J6	O	Frame-sync delayed output. The FSD output synchronizes a slave device to the frame sync of the master device. FSD is applied to the slave FS input and has the same duration as the master FS signal. Requires a pullup resistor if not used.
INM	48	B2	I	Inverting input to analog modulator. INM requires an external R-C antialias filter with low output impedance if the internal antialias filter is bypassed.
INP	47	A2	I	Noninverting input to analog modulator. INP requires an external R-C antialias filter with low output impedance if the internal antialias filter is bypassed.
M0	10	G1	I	Combine with M1 to select serial interface mode (frame-sync mode)
M1	11	G2	I	Combine with M0 to select serial interface mode (frame-sync mode)

## 1.5 Terminal Functions (Continued)

TERMINALS			I/O	DESCRIPTION
NAME	NO.			
	PFB	GQE	I/O	
MCLK	20	J5	I	Master clock. MCLK derives the internal clocks of the sigma-delta analog interface circuit.
M/S	27	F8	I	Master/slave select input. When M/S is high, the device is the master, and when is low, it is a slave.
NC	18, 28, 31, 32, 35, 36, 37, 39, 41, 44	A6, A7, C9, C8, F9		No connection
OUTM	9	F2	O	DACs inverting output. OUTM is functionally identical with and complementary to OUTP.
OUTP	8	F1	O	DACs noninverting output. OUTP can also be used alone for single-ended operation.
PWRDWN	12	H1	I	Power down. When PWRDWN is pulled low, the device goes into a power-down mode, the serial interface is disabled, and most of the high-speed clocks are disabled. However, all register values are sustained and the device resumes full-power operation without reinitialization when PWRDWN is pulled high again. PWRDWN resets the counters only and preserves the programmed register contents. See paragraph 2.2.2 for more information.
RESET	13	J2	I	The reset function is provided to initialize all the internal registers to their default values. The serial port can be configured to the default state accordingly. See Appendix A, <i>Register Set</i> , and Subsection 2.2, <i>Reset and Power-Down Functions</i> for detailed descriptions. All RESET pins of devices in cascade must be tied together.
SCLK	19	H5	I/O	Shift clock. SCLK signal clocks serial data into DIN and out of DOUT during the frame-sync interval. When configured as an output (M/S high), SCLK is generated internally by multiplying the frame-sync signal frequency by 256 (cascade devices < 5) or 512 (cascade devices > 4). When configured as an input (M/S low), SCLK is generated externally and must be synchronous with the master clock and frame sync.
VMID	43	A4	O	Reference voltage output at AVDD/2

## 1.6 Definitions and Terminology

Data transfer interval	The time during which data is transferred from DOUT to DIN. The interval is 16 shift clocks and the data transfer is initiated by the falling edge of the FS signal.
Signal data	This refers to the input signal and all of the converted representations through the ADC channel, and the signal through the DAC channel to the analog output. This is in contrast with the purely-digital software control data.
Primary communication	Primary communication refers to the digital data-transfer interval. Since the device is synchronous, the signal data words from the ADC channel and to the DAC channel occur simultaneously.
Secondary communication	Secondary communication refers to the digital control and configuration data-transfer interval into DIN, and the register read-data cycle from DOUT. The data transfer occurs when requested by hardware or software.
SPI	Serial peripheral interface standard set by Motorola
Frame/pulse sync	Frame/pulse sync refers only to the falling edge of the signal FS that initiates the data-transfer interval. The primary FS starts the primary communication, and the secondary FS starts the secondary communication.
Frame/pulse sync and sampling period	Frame/pulse sync and sampling period is the time between falling edges of successive primary FS signals and it is always equal to 256xSCLK if the number of cascading devices is less than 5, or 512 xSCLK if the number of cascading devices is greater than 4.
f <sub>s</sub>	The sampling frequency
ADC channel	ADC channel refers to all signal-processing circuits between the analog input and the digital conversion result at DOUT.

DAC channel	DAC channel refers to all signal-processing circuits between the digital data word applied to DIN and the differential output analog signal available at OUTP and OUTM.
Host	A host is any processing system that interfaces to DIN, DOUT, SCLK, FS, and/or MCLK.
PGA	Programmable gain amplifier
FIR	Finite-duration impulse response
DCSI	Direct configuration serial interface with host

## 1.7 Register Functional Summary

There are five control registers which are used as follows:

Register 0 The no-op register. Addressing register 0 allows secondary-communication request without altering any other registers.

Register 1 Control register 1. The data in this register has the following functions:

- Produce the output flag to indicate a decimator FIR filter overflow (read cycle only)
- Enable of general-purpose operational amplifiers A1, A3, and A4
- Enable/bypass ADCs analog antialiasing filter
- Select normal or auxiliary analog input
- Control 16-bit or (15+1)-bit mode of DAC operation
- Activate software reset
- Enable/bypass the decimator FIR filter
- Enable/bypass the interpolator FIR filter

Register 2 Control register 2. The data in this register has the following functions:

- Control of the low-power mode that converts data at the rate of 8 ksps
- Control of the N-divide register that determines the filter clock rate and sample period

Register 3 Control register 3. The data in this register has the following functions:

- Software power down
- Selection of analog loopback, digital loopback, and event monitor mode
- Control of continuous data transfer mode
- Control of the value of one-bit general-purpose output flag
- Control the output of FLAG pin
- Enable/disable ADC path
- Enable/disable DAC path
- Control of 16-bit or (15+1)-bit mode of ADC operation

Register 4 Control register 4. The data in this register has the following functions:

- Control of the 4-bit gain of input PGA
- Control of the 4-bit gain of output PGA

## 2 Functional Description

### 2.1 Device Functions

#### 2.1.1 Operating Frequencies

The sampling frequency represented by the frequency of the primary communication is derived from the master clock (MCLK) input with the following equation:

$$F_s = \text{Sampling (conversion) frequency} = \text{MCLK}/(256 \times N), N = 1, 2, \dots, 32$$

The inverse of the sampling frequency is the time between the falling edges of two successive primary frame-sync signals. This time is the conversion period. For example, to set the conversion rate to 8 kHz,  $\text{MCLK} = 256 \times N \times 8000$ .

**NOTE:**The value of N is defined in control register 2 and its power-up value is 32.

#### 2.1.2 ADC Signal Channel

Both IN (INP, INM) and AUX (AURXFP, AURXM) inputs can use the built-in antialiasing filter that can be bypassed by writing a 1 to bit D5 of control register 1. The AUX input can also be connected to the general-purpose amplifier A1 for general-purpose applications, such as electret-microphone interface and 2-to-4-wire hybrid interface, by writing a 1 to bit D6 of control register 1. Bit D4 of control register 1 selects between IN or AUX for the ADC. The selected input signal is amplified by the PGA and applied to the ADC input. The ADC converts the signal into discrete-output digital words in 2s-complement data format, corresponding to the analog-signal value at sampling time. These 16-bit (or 15-bit) digital words, representing sampled values of the analog input signal after PGA, are clocked out of the serial port (DOUT) at the positive edge of SCLK during the frame-sync (FS) interval at the rate of one bit for each SCLK and one word for each primary communication. During secondary communication, the data previously programmed into the registers can be read out. If a register read is not required, all 16 bits are cleared to 0 in the secondary communication. This read operation is accomplished by sending the appropriate register address (D11-D9) with the read bit (D12) set to 1 during present secondary communication. The timing sequence is shown in Figures 2–1 and 2–2.

The decimation FIR filter can be bypassed by writing a 1 to bit D2 of control register 1. The whole ADC channel can be turned off for power savings by writing 01 to bits D2 and D1 of control register 3.

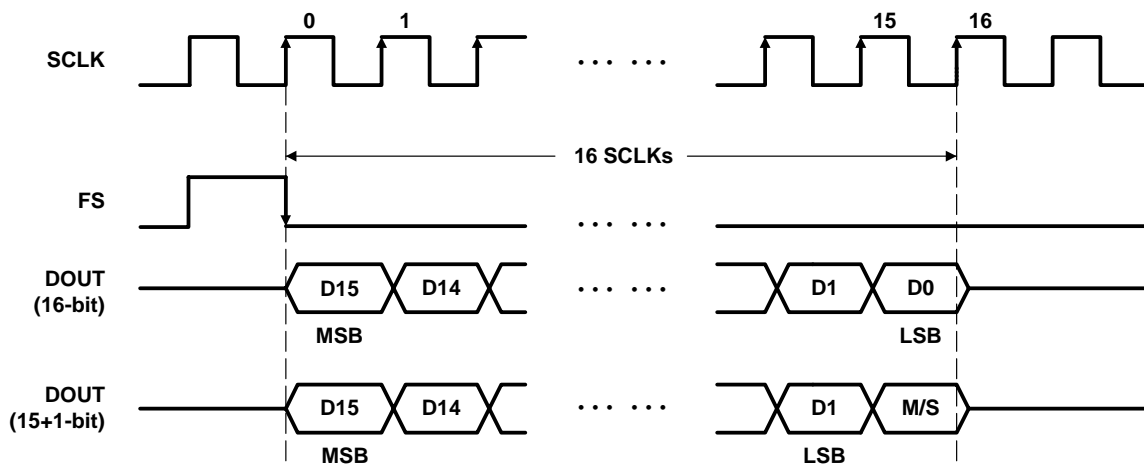

- NOTES: A.  $\overline{M/S}$  is used to indicate whether the 15-bit data comes from a master or a slave device (master:  $M/S=1$ , slave:  $M/S=0$ ).  
 B. The MSB (D15) is stable (the host can latch the data in at this time) at the falling edging of SCLK number 0; the last bit (D0,  $\overline{M/S}$ ) is stable at the falling edging of SCLK number 15.

**Figure 2–1. Timing Sequence of ADC Channel (Primary Communication Only)**

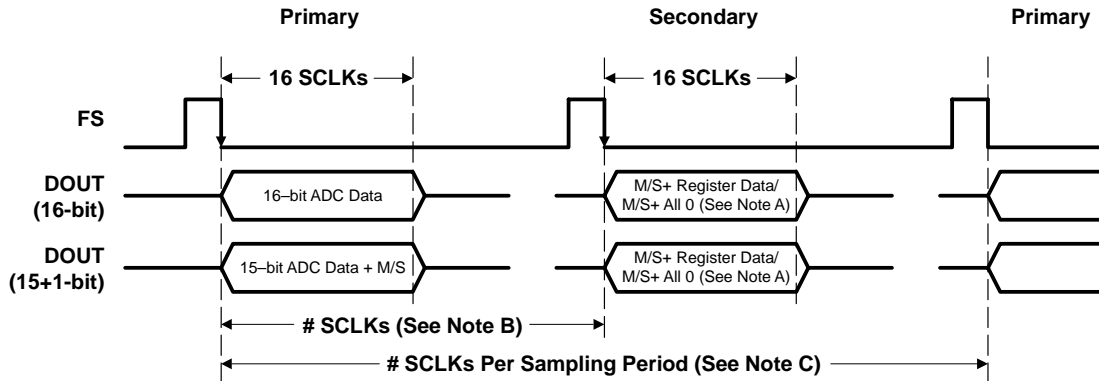

- NOTES: A.  $\overline{M/S}$  bit (D15) in the secondary communication is used to indicate whether the register data (address and content) come from a master device or a slave device if read bit is set. Otherwise, it is all 0s except M/S bit (master: M/S=1, slave: M/S=0).
- B. The number of SCLKs between FS (primary) and FS (secondary) is 128 if cascading devices are less than 5, or 256 if cascading devices are greater than 4.
- C. The number of SCLKs per data sampling period is 256 if cascading devices are less than 5, or 512 if cascading devices are greater than 4.

**Figure 2–2. Timing Sequence of ADC Channel (Primary and Secondary Communication)**

### 2.1.3 DAC Signal Channel

DIN received the 16-bit serial data word (2s complement) from the host during the primary communication interval. These 16-bit digital words, representing analog output signal before PGA, are clocked into the serial port (DIN) at the falling edge of SCLK during the frame-sync interval, one bit for each SCLK and one word for each primary communication interval. The data are converted to a pulse train by the sigma-delta DAC comprised of a digital-interpolation filter and a digital 1-bit modulator. The output of the modulator is then passed to an internal low-pass filter to complete the signal reconstruction. Finally, the resulting analog signal applied to the input of a programmable-gain amplifier is capable of differentially driving a 600-ohm load at OUP and OUTM. The timing sequence is shown in Figure 2–3.

During secondary communication, the digital control and configuration data, together with the register address, are clocked in through DIN (see Appendix A for register map). These 16-bit data are used either to initialize the register or read out register content through DOUT. If a register initialization is not required, a no-operation word (D15-D9 are all set to 0) can be used. If D12 is set to 1, the content of the control register, specified by D7-D0, are sent out through DOUT during the same secondary communication (see Section 2.1.5). The timing sequence is shown in Figure 2–4.

The interpolation FIR filter can be bypassed by writing a 1 to bit D2 of control register 1. The whole DAC channel can be turned off for power savings by writing 10 to bits D2 and D1 of control register 3.

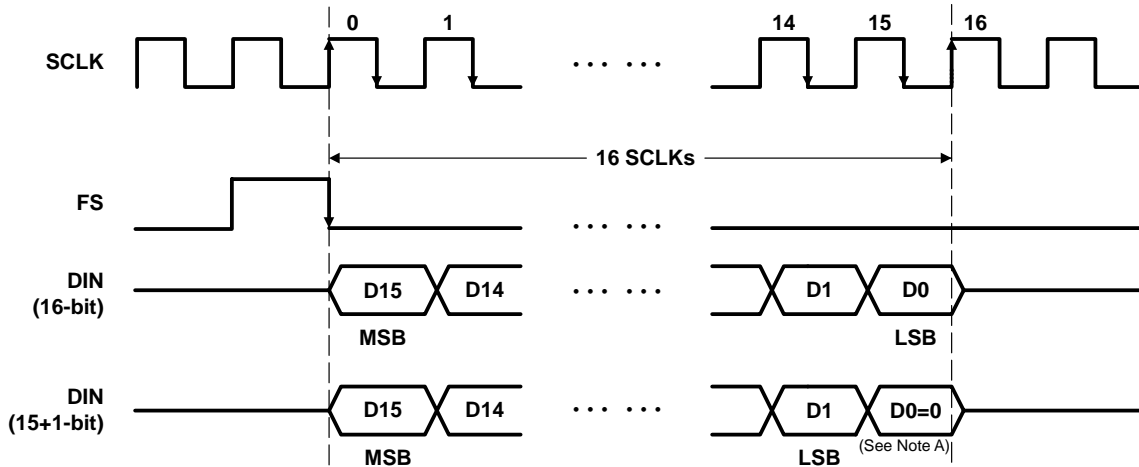

NOTE A: d0 = 0 means no secondary-communication request (software secondary-request control, see Section 3.2).

**Figure 2–3. Timing Sequence of DAC Channel (Primary Communication Only)**

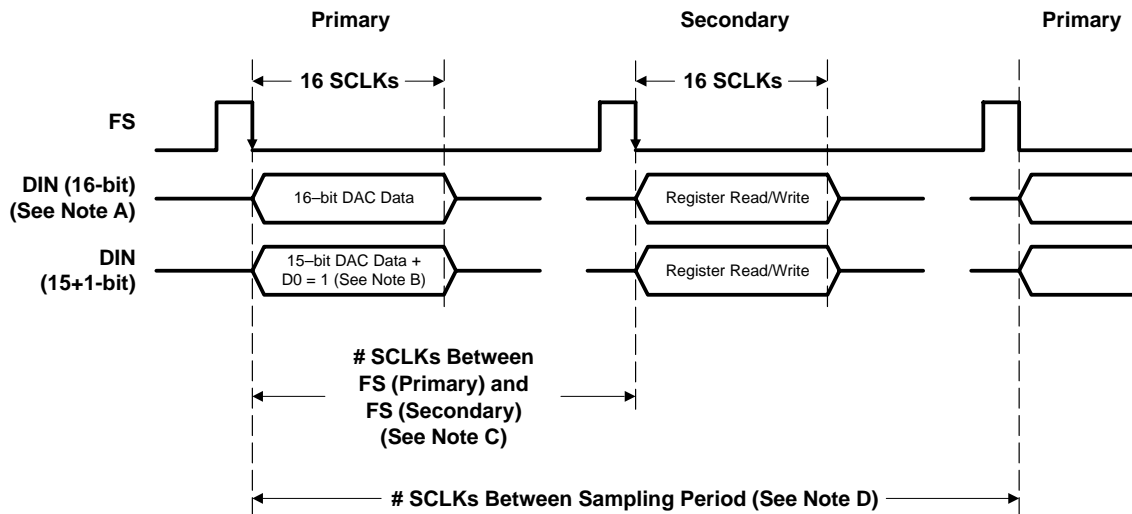

- NOTES: A. FC has to be set high for a secondary communication request when 16-bit DAC data format is used (see Section 3.2).  
 B. D0 = 1 means secondary communication request (software secondary request control, see Section 3.2)  
 C. The number of SCLKs between FS (Primary) and FS (Secondary) is 128 if cascading devices are less than 5, or 256 if cascading devices are greater than 4.  
 D. The number of SCLKs per data sampling period is 256 if cascading devices are less than 5, or 512 if cascading devices are greater than 4.

**Figure 2–4. Timing Sequence of DAC Channel (Primary and Secondary Communication)**

## 2.1.4 MIC Input

The auxiliary inputs (AURXFP, AURXCP, and AURXM) can be programmed to interface with a microphone such as an electret microphone, as illustrated in Figure 2.5, by writing a 1 to bit D6 and D4 of control register 1. Enabling MIC input with DG automatically selects AURx channel for ADC input.

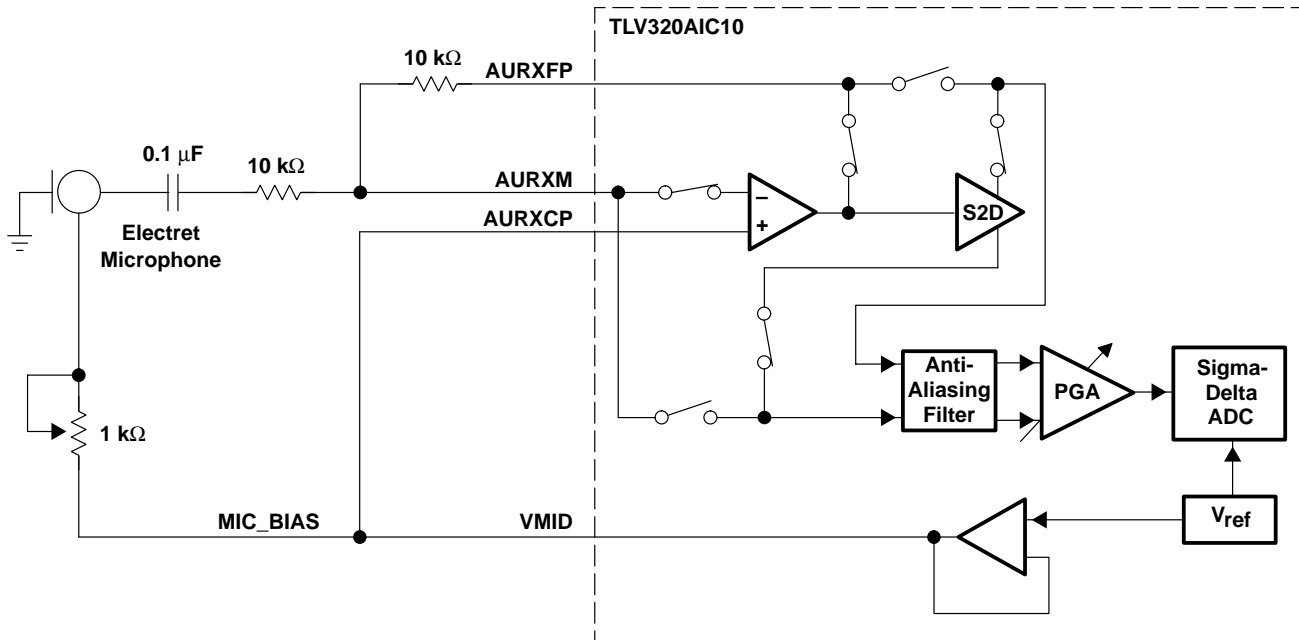

Figure 2–5. Typical Microphone Interface

## 2.1.5 Antialiasing Filter

The built-in antialiasing filter has a 3-dB cutoff frequency of 70 kHz.

## 2.1.6 Sigma-Delta ADC

The sigma-delta analog-to-digital converter is a sigma-delta modulator with 128× oversampling. The ADC provides high-resolution, low-noise performance using oversampling techniques. Due to the oversampling employed, only single-pole RC filters are required on the analog inputs.

## 2.1.7 Decimation Filter

The decimation filters reduce the digital data rate to the sampling rate. This is accomplished by decimating with a ratio of 1:64. The output of the decimation filter is a 16-bit 2s-complement data word clocking at the sample rate selected for that particular data channel. The BW of the filter is  $0.45 \times FS$  and scales linearly with the sample rate.

## 2.1.8 Sigma-Delta DAC

The sigma-delta digital-to-analog converter is a sigma-delta modulator with 128× oversampling. The DAC provides high-resolution, low-noise performance using oversampling techniques.

## 2.1.9 Interpolation Filter

The interpolation filter resamples the digital data at a rate of 64 times the incoming sample rate. The high-speed data output from the interpolation filter is then used in the sigma-delta DAC. The BW of the filter is  $0.45 \times FS$  and scales linearly with the sample rate.

### 2.1.10 Analog and Digital Loopback

The analog and digital loopbacks provide a means of testing the modem data ADC/DAC channels and can be used for in-circuit system level tests. The analog loopback routes the DAC low-pass filter output into the analog input where it is then converted by the ADC to a digital word. The digital loopback routes the ADC output to the DAC input on the device. Analog loopback is enabled by writing 01 to bits D7 and D6 respectively in control register 3. Digital loopback is enabled by writing 10 to bits D7 and D6 in control register 3 (see Appendix A).

### 2.1.11 FIR Overflow Flag

The decimator FIR filter sets an overflow flag (bit D7) in control register 1 to indicate that the input analog signal has exceeded the range of the internal decimation-filter calculations. When the FIR overflow flag has been set in the register, it remains set until the register is read by the user. Reading this value resets the overflow flag.

If FIR overflow occurs, the input signal has to be attenuated either by the PGA or some other method.

### 2.1.12 FIR Bypass Mode

An option is provided to bypass the FIR filter sections of the decimation and interpolation filters. This mode is selected through bit D2 of control register 1, and effectively increases the frequency of the FS and SCLK signals to 4 times the normal FIR-filter output rate, since the decimation/interpolation factor of the bypassed filter stage is 4. The sinc filters of the two paths can not be bypassed.

The AIC10 is capable of supporting a maximum of four devices in cascade.

If the FIR filter is bypassed, the signal-to-noise ratio (SNR) is reduced to 69 dB. The FIR bypass mode offers users the flexibility to implement their own decimation/interpolation FIR filter based on application-specific requirements. For example users can select this mode to bypass both decimation and interpolation FIR filters and implement a lower-order FIR filter or an IIR filter externally in the DSP for applications that require group delays smaller than 17/Fs, which is the AIC10s total group delay.

### 2.1.13 Low-Power Mode

To select the low-power mode, in which the AIC10 typically consumes 38.6 mW, set bit D7 of control register 2 to 1 and set the sampling rate at 8 ksps.

### 2.1.14 Event-Monitor Mode

This mode is only available during the register-write cycle, and is enabled by writing 11 to bits D6 and D7 of control register 3; performing a register read terminates event-monitor mode. The event monitor mode is provided for applications that need hardware control and monitoring of external events. By allowing the device to drive the FLAG terminal (set through bit D3 of the control register 3), the host DSP is capable of system control through the same serial port that connects the device. Along with this control is the capability of monitoring the value of the ALTIN terminal during a secondary communication cycle. One application of this function is in monitoring RING DETECT or OFFHOOK DETECT from a phone-answering system. FLAG allows response to these incoming control signals. Figure 2-6 shows the timing associated with this operating mode.

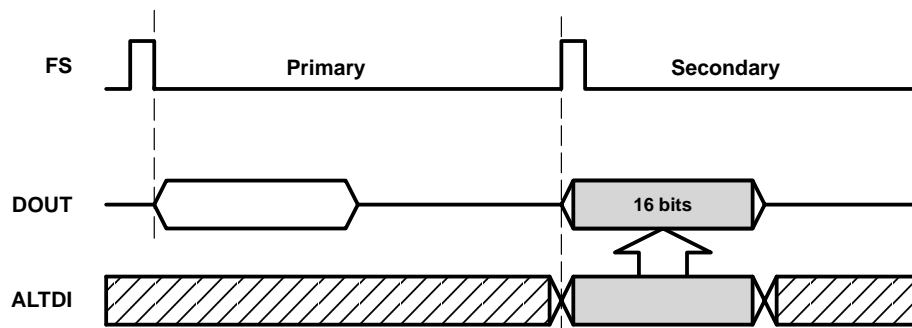

NOTE A: When DIN performs a write operation (sets D12 to 0) during secondary communication.

Figure 2-6. Event Monitor Mode Timing

## 2.2 Reset and Power-Down Functions

### 2.2.1 Software and Hardware Reset

The TLV320AIC10 resets the internal counters and registers in response to either of two events:

- A low-going reset pulse is applied to terminal RESET
- A 1 is written to the programmable-software reset bit (D3 of control register 1)

Either event resets the control registers and clears all the sequential circuits in the device. Reset signals should be at least six master-clock periods long. It is recommended to synchronize the reset signal with the master clock in master/slave cascade, and to tie all reset pins together. For devices in cascade, it takes at least two FS cycles to apply software reset to all devices, with the master being always programmed last.

### 2.2.2 Software and Hardware Power Down

With the exception of the digital interface, the device enters the power-down mode when D1 and D2 in control register 3 are set to 1. When PWRDWN is taken low, the entire device is powered down. In either case, the register contents are preserved and the output of the monitor amplifier is held at the midpoint voltage to minimize pops and clicks.

The amount of power drawn during software power down is higher than it is during a hardware power down because of the current required to keep the digital interface active. Additional differences between software and hardware power-down modes are detailed in the following paragraphs. Figure 2–7 represents the internal power-down logic.

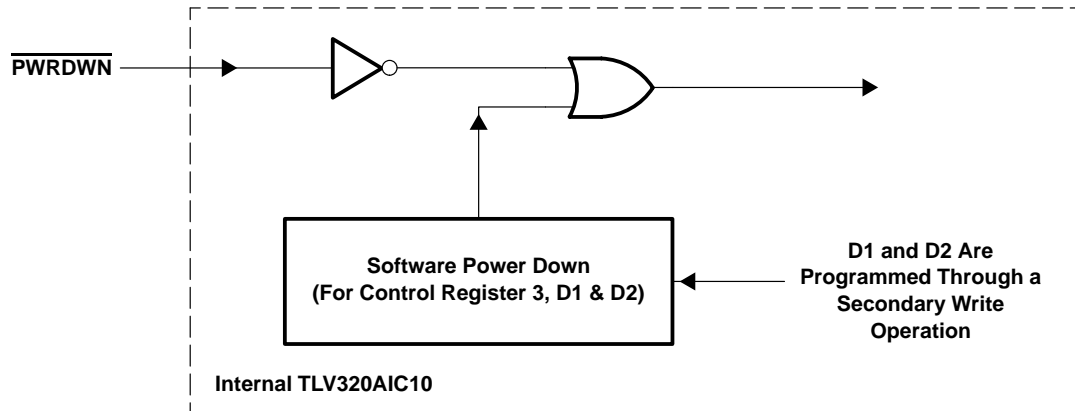

Figure 2–7. Internal Power-Down Logic

#### 2.2.2.1 Software Power Down

When D1 and D2 of control register 3 are set to 1, TLV320AIC10 enters the software power-down mode. In this state, the digital-interface circuit is still active, while the internal ADC and DAC channels and differential outputs OUTP and OUTM are disabled, and DOUT and FSD are inactive. Register data in secondary serial communications is still accepted, but data in primary serial communications is ignored. The device returns to normal operation when D1 and D2 of control register 3 are reset.

#### 2.2.2.2 Hardware Power Down

When  $\overline{\text{PWRDWN}}$  is held low, the device enters the hardware power-down mode. In this state, the internal-clock control circuit and the differential outputs OUTP and OUTM are disabled. All other digital I/Os are either disabled, or remain in the same state they were in immediately before power down. DIN can not accept any data input. The device can only be returned to normal operation by taking and holding  $\overline{\text{PWRDWN}}$  high. When not holding the device in the hardware power-down mode,  $\overline{\text{PWRDWN}}$  should be tied high.

## 2.3 Clock Source

MCLK is the external master-clock input. The clock circuit generates and distributes the necessary clocks throughout the device. When the device is in the master mode, SCLK and FS are output and derived from MCLK in order to provide clocking of the serial communications between the device and a DSP (digital signal processor). When in the slave mode, SCLK and FS are all inputs. The SCLK can be connected to a faster clock source to speed up serial communication between the slave and the master while the internal clock is maintained at 256 clocks per FS period for internal processing. In SPI mode, the device is a slave and SCLK is connected to the SPICLK source.

## 2.4 Data Out (DOUT)

DOUT is placed in the high-impedance state after completing transmission of the LSB. In primary communication the data word is the ADC conversion result. In secondary communication the data in the register read results when requested by the read/write ( $R/\overline{W}$ ) bit. If a register read is not requested, the low eight bits of the secondary word are all zeroes. The state of the master/slave (M/S) terminal is reflected by the MSB in secondary communication (DOUT, bit D15), and by the LSB in primary communication (DOUT, bit D0).

### 2.4.1 Data Out, Master Mode

In the master mode, DOUT is taken from the high-impedance state by the falling edge of the master frame-sync (FS). The most significant data bit then appears first on DOUT.

### 2.4.2 Data Out, Slave Mode

In the slave mode, DOUT is taken from the high-impedance state by the falling edge of the external frame-sync (FS). The most significant data bit then appears first on DOUT.

## 2.5 Data In (DIN)

In a primary communication, the data word is the input digital signal to the DAC channel. If (15+1)-bit data format is used, the LSB (D0) is used to request a secondary communication. In a secondary communication, the data is the control and configuration data that sets the device for a particular function (see Section 3, *Serial Communications*). The LSB of control register 1 determines whether it is a 15-bit or a 16-bit input.

## 2.6 FC (Hardware Secondary Communication Request)

The FC input provides for hardware requests for secondary communications. FC works in conjunction with the LSB of the primary data word. FC should be tied low if not used.

## 2.7 Frame-Sync Function for TLV320AIC10

The frame-sync signal (FS) indicates the device is ready to send or receive data. FS is an output if the M/S pin is connected to HI (master mode), and an input if the M/S pin is connected to LO (slave mode). The output FSD is a delay version of the first frame-sync signal (FS) that is output 32 SCLKs after the first FS, and serves as the frame-sync input to the next slave (see Figure 2–14). The data transferred out of DOUT and into DIN begins on the falling edge of the FS signal. It can be configured as a frame or as a pulse signal, as determined by pins M0 and M1.

In normal operation, the digital serial interface consists of the shift clock (SCLK), the frame-sync signal (FS), the ADC-channel data output (DOUT), and the DAC-channel data input (DIN). During the primary frame-synchronization interval, SCLK clocks the ADC channel results out through DOUT, and clocks 16-bit/(15+1) DAC data in through DIN.

During the secondary frame-sync interval, SCLK clocks the register data out through DOUT in normal operation. If the read bit (D12) is set to 1 and the device transfers control and device parameter in through DOUT. The timing sequence is shown in Figures 2-1, 2-2, 2-3, and 2-4.

The TLV320AIC10 has four serial-interface modes that support most modern DSP engines. This modes can be selected by M0 and M1. In mode 0 (Figure 2–8), FS is one-bit wide and it is active high one SCLK period before the first bit (MSB) of each data transmission. In modes 1 (Figure 2–9) and 2 (Figure 2–10), the TLV320AIC10 operates as a slave to interface with an SPI master in which FS is the SPISEL that determines the sampling rate. SCLK needs to be free-running. In mode 3 (Figure 2–11), FS is low during data transmission into DIN and DOUT.

**Table 2–1. Serial Interface Modes**

MODE	M1	M0	FRAME SYNC (FS) FORMAT
0	0	0	Pulse mode
1	0	1	SPI_CP0 mode (SPI mode 0)
2	1	0	SPI_CP1 mode (SPI mode 1)
3	1	1	Frame mode

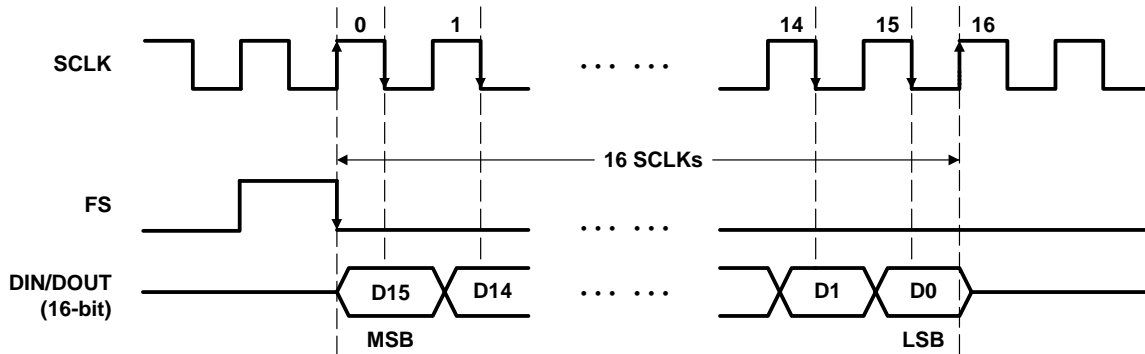

**Figure 2–8. Timing Diagram for the FS Pulse Mode (M1M0 = 00)**

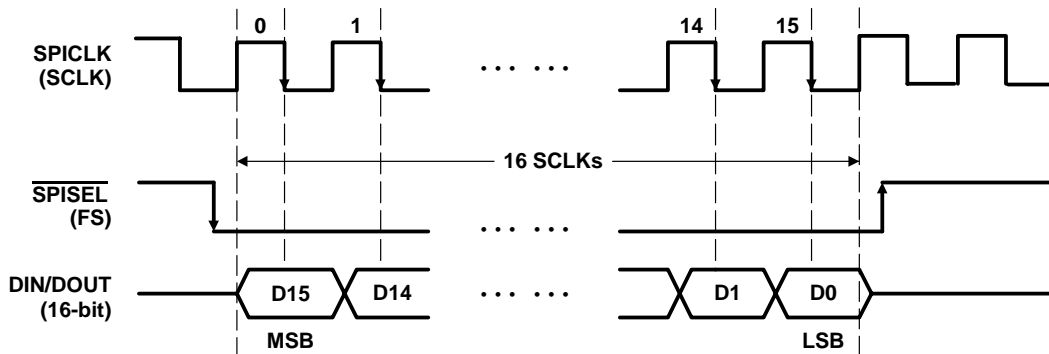

**Figure 2–9. Timing Diagram for the SPI\_CP0 Mode (M1M0 = 01)**

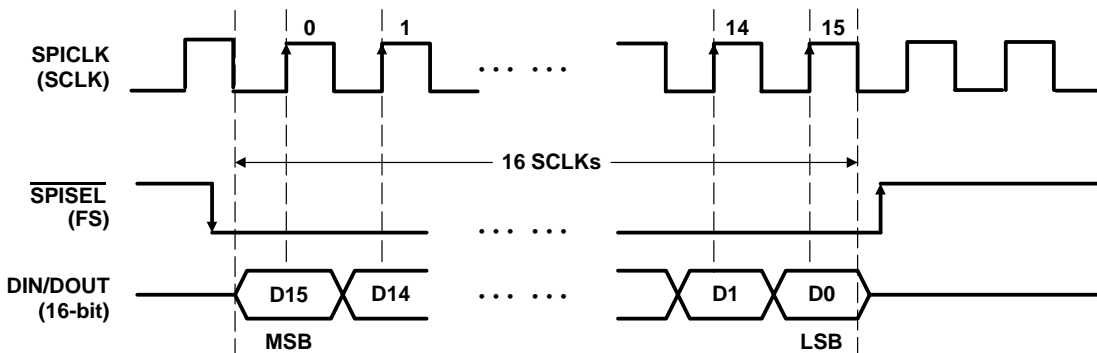

**Figure 2–10. Timing Diagram for the SPI\_CP1 Mode (M1M0 = 10)**

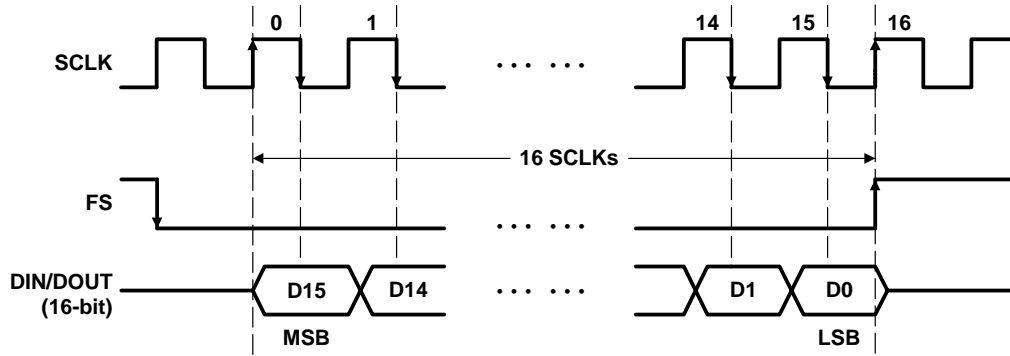

**Figure 2–11. Timing Diagram for the FS Frame Mode (M1M0 = 11)**

NOTE: In frame mode, if AIC10 is in slave mode, DIN/DOOUT should be delayed by one SCLK from the falling edge of FS.

### 2.7.1 Frame-Sync (FS) Function—Continuous-Transfer Mode (Master Only)

Writing a 1 to bit D5 of control register 3 enables the continuous-transfer mode. In this mode, the data bits are transmitted and received contiguously with no inactivity between bits at the very next FS, and no further frame sync FSs are generated. Secondary communication is not available. To disable the continuous transfer mode, use the direct-configuration mode (see Section 3.3) or reset the device.

### 2.7.2 Frame-Sync (FS) Function—Fast-Transfer Mode (Slave Only)

By connecting the fast clock to the SCLK pin, data can be transmitted and received at a higher rate than 256 x Fs in the slave mode for a stand-alone AIC10.

### 2.7.3 Frame-Sync (FS) Function—Master Mode

The master mode in the TLV320AIC10 is selected by connecting pin M/S pin to HI. In the master mode, the TLV320AIC10 generates the frame-sync signal (FS) to the DSP that goes low on the rising edge of SCLK and remains low during a 16-bit data transfer.

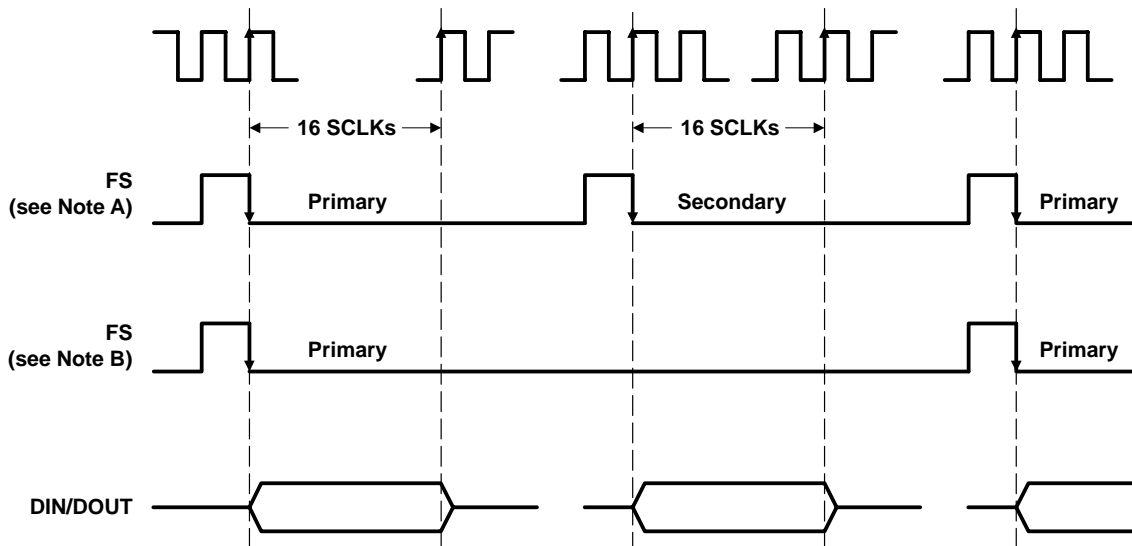

NOTES: A. Primary and secondary serial communications  
B. Primary serial communication only

**Figure 2–12. Master Device Frame-Sync Signal With Primary and Secondary Communication ( No Slaves)**

## 2.7.4 Frame-Sync (FS) Function—Slave Mode

The slave mode is selected by connecting pin M/S to LO. The frame-sync timing is generated externally by the master, as shown in Figure 2–13 (that is, FSD) and is applied to FS of the slave to control the ADC and DAC timing.

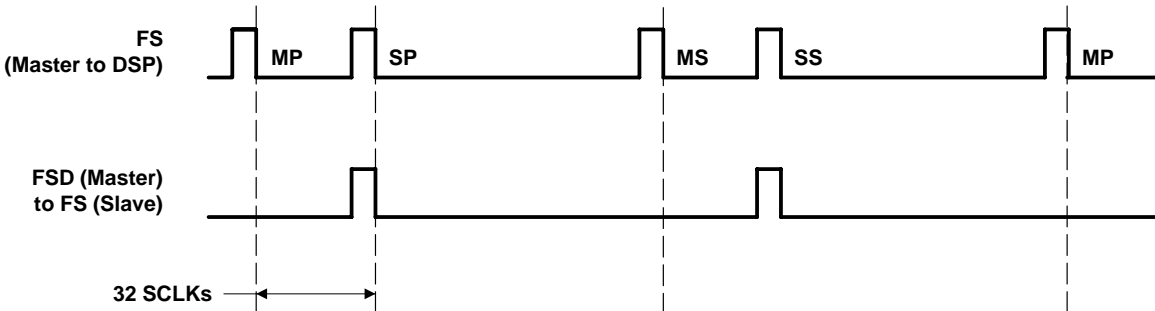

NOTE: MP: master primary (master-device data is transferred during this period, the DOUT of the slave device is in high-impedance state).  
 SP: slave primary (slave device data is transferred during this period, the DOUT of master device is in high-impedance state).  
 MS: master secondary (master device control register information is transferred during this period, the DOUT of slave device is in high-impedance state).  
 SS: slave secondary (slave device control register information is transferred during this period, the DOUT of master device is in high-impedance state).

Figure 2–13. Master Device’s FS Output to DSP and FSD Output to the Slave

## 2.7.5 Frame-Sync Delayed (FSD) Function, Cascade Mode

In cascade mode, the DSP must be able to identify the master and slaves according to the register map shown in Appendix A. Each device in the cascade contains a 3-bit cascade register (D15-D13 in the register address) that has been programmed by the ACD (automatic cascade detection) with an address value equal to its position in the cascade during the device’s power-up initialization (see Appendix A). The device address of the master is always equal to the number of slaves in the cascade. For example, in Figure 2–14, D15-D13 of the master is 011, as shown in row 4 of Table A-1 (Appendix A). The DSP receives all frame-sync pulses from the master through the master’s FS. The master FSD is output to the first slave, and the first slave FSD is output to the second slave device, and so on. Figure 2–14 shows the cascade of 4 TLV320AIC10s in which the closest one to the DSP is the master, and the rest are slaves. The FSD output of each device is input to the FS terminal of the succeeding device. Figure 2–15 shows the FSD timing sequence in the cascade.

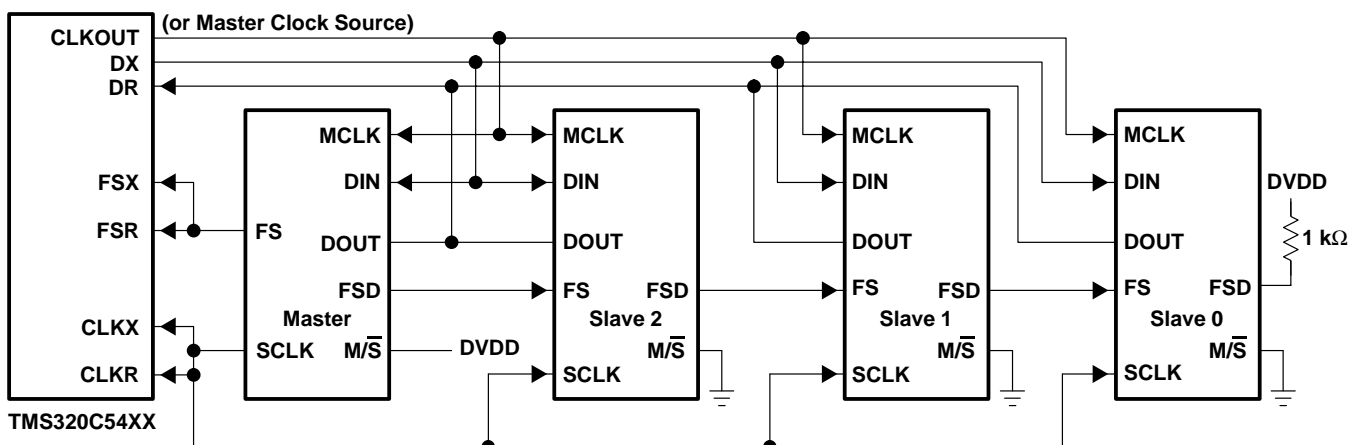

Figure 2–14. Cascade Mode Connection (to DSP Interface)

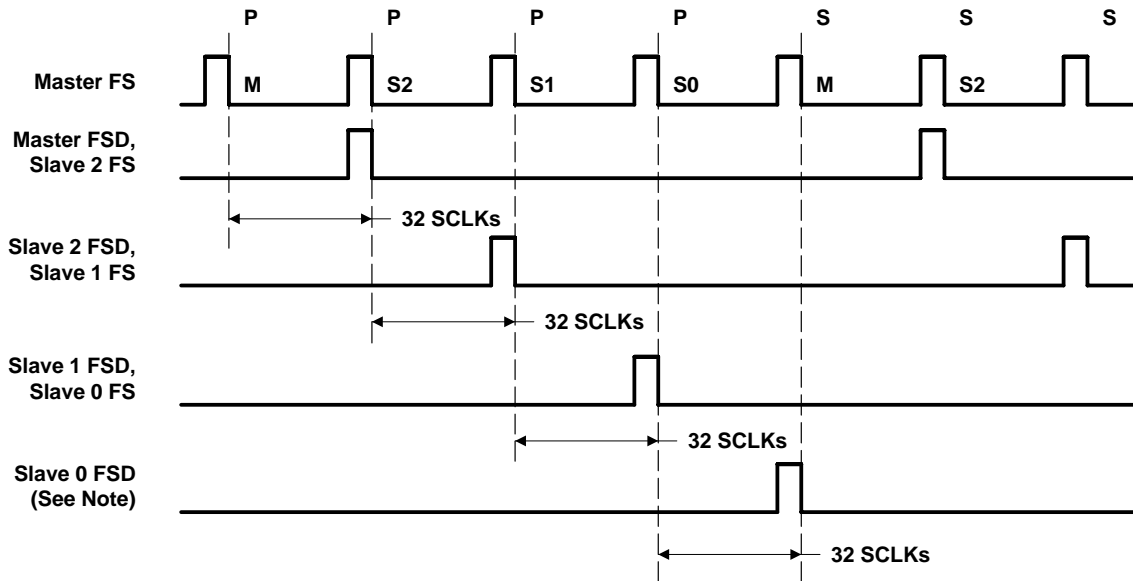

Figure 2–15. Master-Slave Frame-Sync Timing

## 2.8 Multiplexed Analog Input and Output

The two differential analog inputs (INP and INM, or AUXP and AUXM) are multiplexed into the sigma-delta modulator. The performance of the AUX channel is similar to the normal-input channel. The gain of the input amplifiers is set through control register 4.

### 2.8.1 Multiplexed Analog Input

To produce excellent common-mode rejection of unwanted-signal performance, the analog signal is processed differentially until it is converted to digital data. The signal applied to the INM and INP terminals should be differential to preserve the device specifications. The signal source driving the analog inputs (INP and INM, or AUXP and AUXM) should have a low source impedance to attain the lowest noise performance and accuracy. To obtain maximum dynamic range, the signal should be ac-coupled to the input terminal. The analog input signal is self-biased to the mid-supply. Bits D3 and D4 of control register 1 select these input sources. The default condition self-biases the input, since the register default value selects INP and INM as the sources for the ADC.

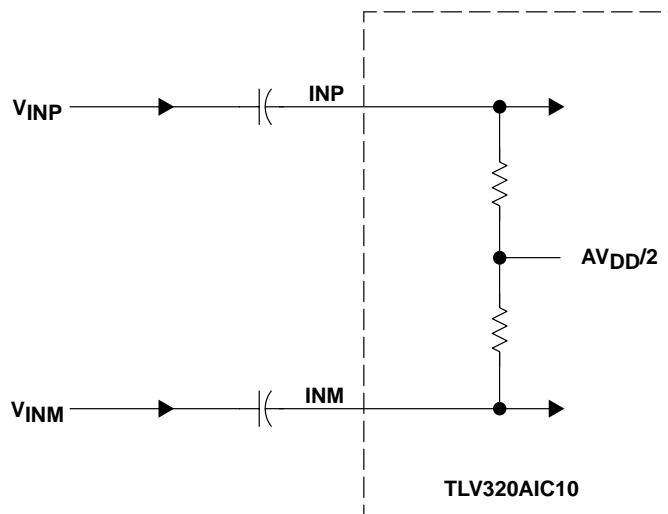

Figure 2–16. INP and INM Internal Self-Biased ( $AV_{DD}/2$ ) Circuit

## 2.8.2 Analog Output

OUTP and OUTM are differential outputs and can typically drive a 600-Ω load directly. Figure 2–17 shows the circuit when the load is ground-referenced.

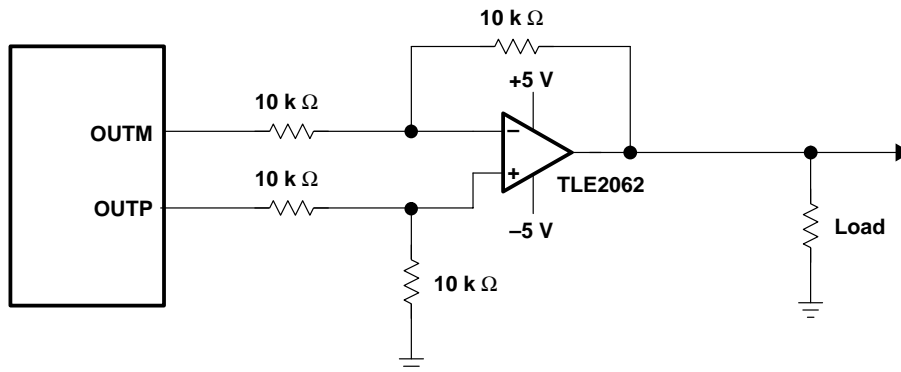

Figure 2–17. Differential Output Drive (Ground-Referenced)

## 2.8.3 Single-Ended Analog Input

The two differential inputs (INP and INM, or AUXP and AUXM) can be configured to work as single-ended inputs by connecting INP or AUXP to the analog input, and INM or AUXM to the external common-mode input. This is illustrated in Figure 2–18.

Following are the valid single-ended input configuration:

- If the signal common-mode is about 2.5 V, then connect signal to INP and its common mode to INM.
- If the common mode of the input signal is different from 2.5 V, then capacitively couple signal onto INP and capacitively couple common mode onto INM.  
Special case: If common mode of signal is AGND, then capacitively couple AGND onto INM.

Whenever INP and INM are both capacitively coupled the device internally sets the bias. Never connect AGND directly to INM. It sets input common mode to AGND which would mean the negative going signal gets clamped.

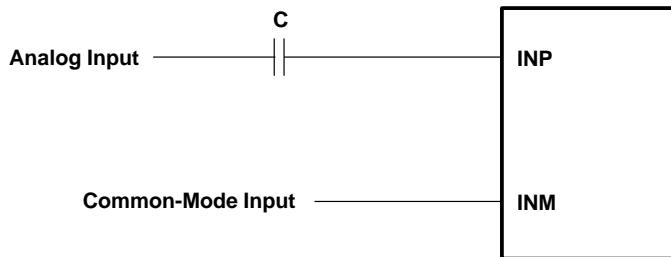

Figure 2–18. Single-Ended Input

## 2.8.4 Single-Ended Analog Output

The differential output of TLV320AIC10 can be configured as a single-ended output. This is illustrated in Figure 2–19.

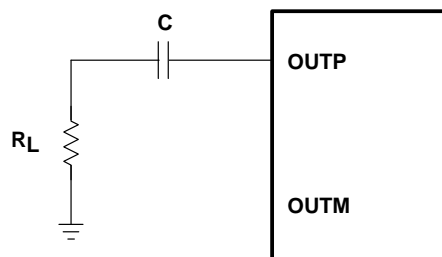

Figure 2–19. Single-Ended Output

### 3 Serial Communications

DOUT, DIN, SCLK, SXCLK, FS, and Fc are the serial communication signals. SCLK is used to perform internal processing and data transfer for serial interface between AIC10 and DSP. In the pulse/frame FS mode, there are 256 SCLKs per sampling period (512 if there are more than 4 devices in cascade). The digital-output data for the ADC is taken from DOUT. The digital-input data for the DAC is applied to DIN. The synchronization clock for the serial communication data and the frame-sync is taken from SCLK. The frame-sync signal that starts the ADC and DAC data-transfer interval is taken from FS. Primary serial communication is used for signal data transmitted from the ADC or to the DAC. Secondary communication is used to read or write words that control both the options and the circuit configurations of the device.

The purpose of the primary and secondary communications is to allow conversion data and control data to be transferred across the same serial port. A primary transfer is always dedicated to conversion data. A secondary transfer or an asynchronous communication is used to set up and/or read the register values. A primary transfer occurs for every conversion period. A secondary transfer occurs only when requested. Secondary serial communication can be requested either by hardware (FC terminal) or by software (D0 of primary data input to DIN). The direct configuration mode uses pin DCSI to program control registers instantly.

#### 3.1 Primary Serial Communication

Primary serial communication is used to transmit and receive conversion signal data. The DAC word length depends on the states of bit D0 in control register 1. After power up or reset, the device defaults to 15-bit mode. When the DAC word length is 15 bits, the last bit of the primary 16-bit serial communication word is a control bit used to request secondary serial communication. In the 16-bit mode, all 16 bits of the primary-communication word are used as data for the DAC, and the hardware terminal FC must be used to request secondary communication.

Figure 3-1 shows the timing relationship for SCLK, FS, DOUT, and DIN in a primary communication. The timing sequence for this operation is as follows:

- FS is brought low by the TLV320AIC10.
- A 16-bit word is transmitted from the ADC (DOUT), and then a 16-bit word is received from the DAC (DIN).

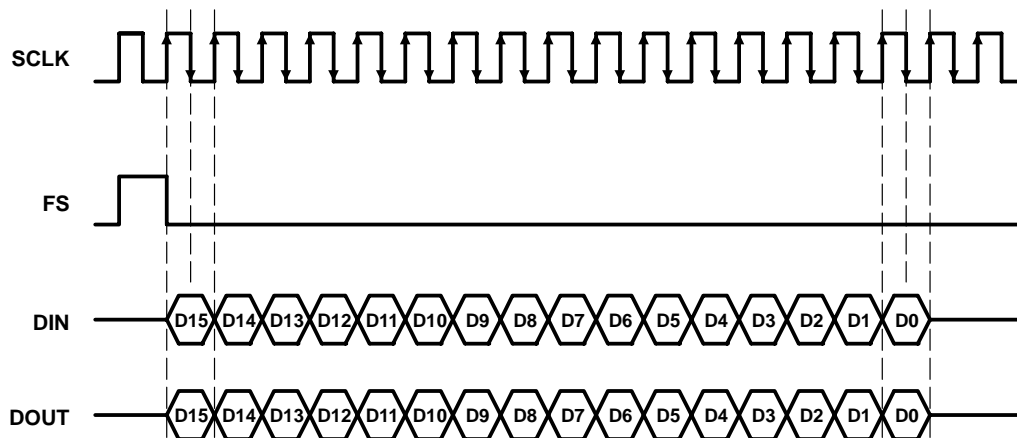

Figure 3–1. Primary Serial Communication Timing

### 3.2 Secondary Serial Communication

Secondary serial communication is used to read or write 16-bit words that program both the options and the circuit configurations of the device. Register programming always occurs during secondary communication. Four primary and secondary communication cycles are requested to program the four registers. If the default value for a particular register is desired, then the register addressing can be omitted during secondary communications. The NOOP command addresses a pseudo-register (register 0), and no register programming takes place during this secondary communication. If secondary communication is desired for any device (either master or slave), then a secondary communication must be requested for all devices, starting with the master. This results in a secondary frame-sync (FS) for all devices. The NOOP command can be used for devices that do not need a secondary operation.

During a secondary communication, a register can be written to or read from. When writing to a register, DIN contains the value to be written. The data returned on DOUT is + 000000000000 (3-bit device address).

There are two methods of initiating a secondary communication, as illustrated in Figure 3–2:

- Asserting a high level on FC (hardware request)
- Asserting the LSB of the DIN 16-bit serial communication high while in the 15-bit mode (software request)

**NOTE:**The secondary communication request should not be asserted during the first two samples after power up.

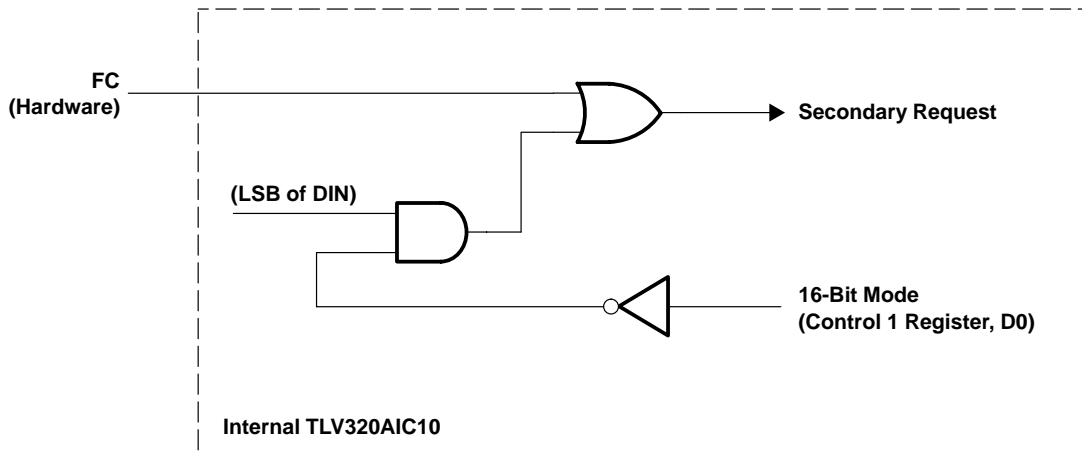

**Figure 3–2. Hardware and Software Secondary Communication Request**

Pulling FC high causes the start of the secondary communications 128 or 256 SCLKs (see Figures 2–2 and 2–4) after the start of the primary communication frame, depending on the number of devices in cascade.

The second method to initiate a secondary communication is asserting the LSB high. A software request is typically used when the request resolution of the DAC channel is less than 16 bits. Then the least significant bit (D0) can be used for secondary requests, as shown in Table 3–1. The request is made by placing the device in the 15-bit DAC mode and making the LSB of DIN high. All cascading devices must be in 15-bit DAC mode, and set their LSBs to 1s for requesting software secondary communication.

**Table 3–1. Least Significant Bit Control Function**

CONTROL BIT D0	CONTROL BIT FUNCTION
0	No operation (NOOP)
1	Secondary communication request

### 3.2.1 Register Programming

All register programming occurs during secondary communication through DIN or ALTI, and data are latched and valid on the falling edge of the SCLK during the frame-sync signal. If the default value of a particular register is desired, that register does not need to be addressed during the secondary communication interval. The NOOP command (DS15-DS8 all set to 0) addresses the pseudo-register (register 0), and no register programming takes place during the communication.

In addition, each register can be read back through DOUT during secondary communications by setting the read bit (D12) to 1. When a register is in the read mode, no data can be written to the register during this cycle. A subsequent secondary communication is required to return this register to the write mode.

For example, if the contents of control register 1 of device 3 are desired to be read out from DOUT, the following procedure must be performed through DIN:

- Request secondary communication by setting either D0 = 1 (software request), or FC = high (hardware request) during the primary communication interval.
- During the secondary communication interval (FS), send data in through DIN using the following format:

Device Address			RW	Register Address			X	Register Content									
0	1	1	1	0	0	1	x	x	x	x	x	x	x	x	x	x	
DS15																	DS0

- Then, during the same frame, the following data is read from DOUT; the last 8 bits of DOUT contains register 1 data.

Device Address			RW	Register Address			X	Register Content									
0	1	1	x	x	x	x	x	d	d	d	d	d	d	d	d	d	
DS15																	DS0

Figure 3–3 is the timing diagram of this procedure.

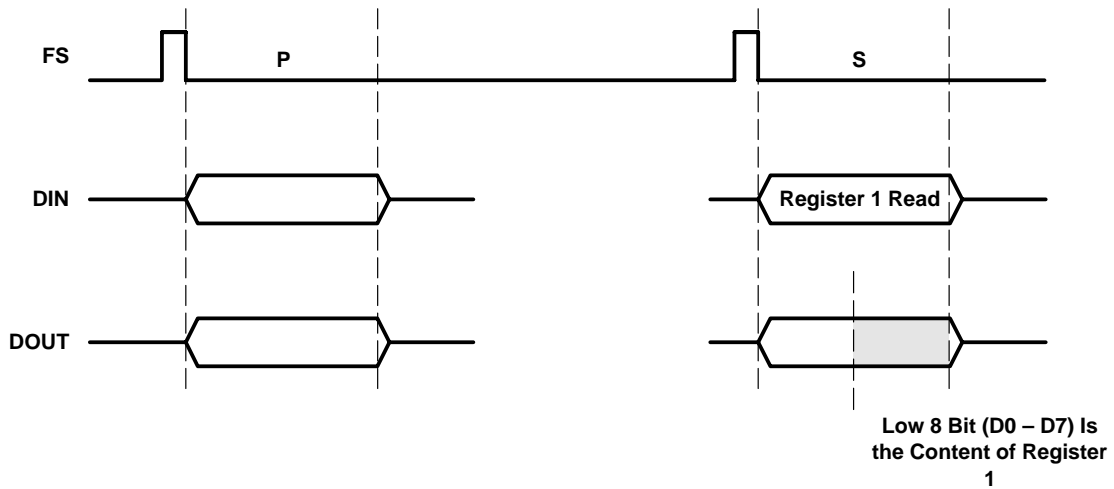

Figure 3–3. Device 3/Register 1 Read Operation Timing Diagram

To program control register 1, the following procedure must be performed through DIN:

- Request secondary communication by setting either D0=1 (software request), or FC = high (hardware request) during the primary communication interval.
- At the secondary communication interval (FS), send data in the following format through DIN:

Device Address			RW	Register Address			X	Register Content							
0	1	1	0	0	0	1	x	d	d	d	d	d	d	d	d

DS15 DS0

- The following is the data out of DOUT.

Device Address			RW	Register Address			X	Register Content							
0	1	1	0	x	x	x	x	0	0	0	0	0	0	0	0

DS15 DS0

Figure 3–4 is the timing diagram of this procedure.

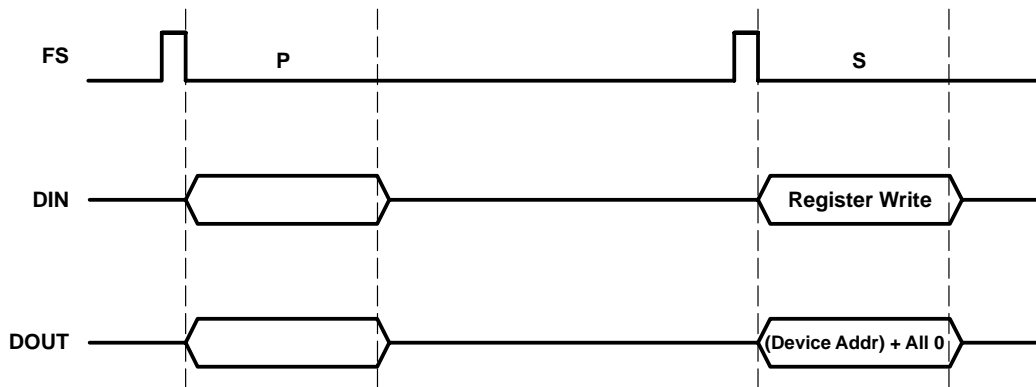

Figure 3–4. Device 3/Register 1 Write Operation Timing Diagram

### 3.2.2 Hardware Secondary Serial Communication Request

A secondary communication can be requested by asserting an FC pulse that sets an internal flag. This flag is reset as soon as the programming of control registers is finished. Thus, one FC pulse needs to be asserted per secondary communication request. Figures 3–5 and 3–6 show the FS output from a master device.

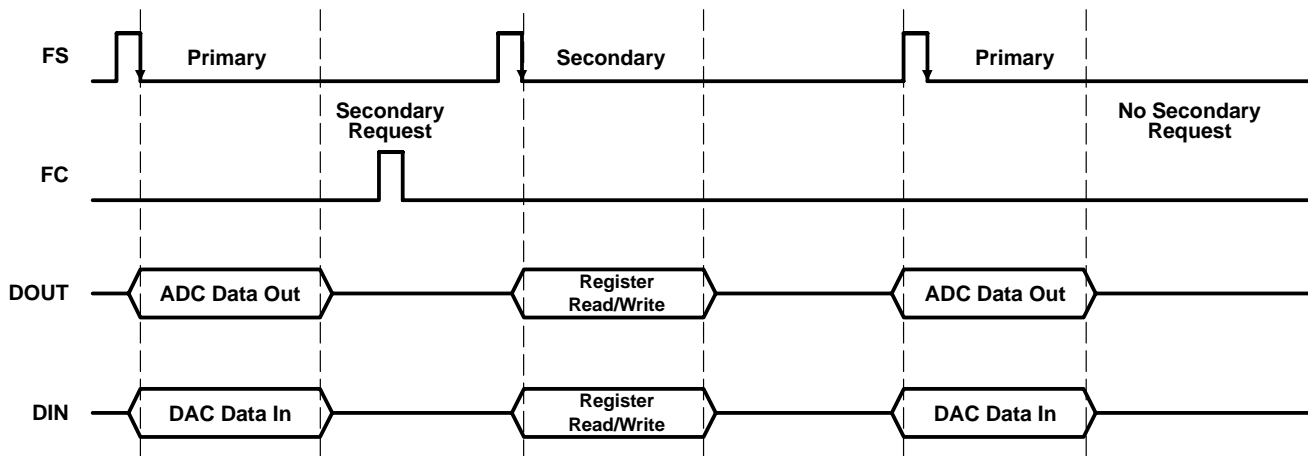
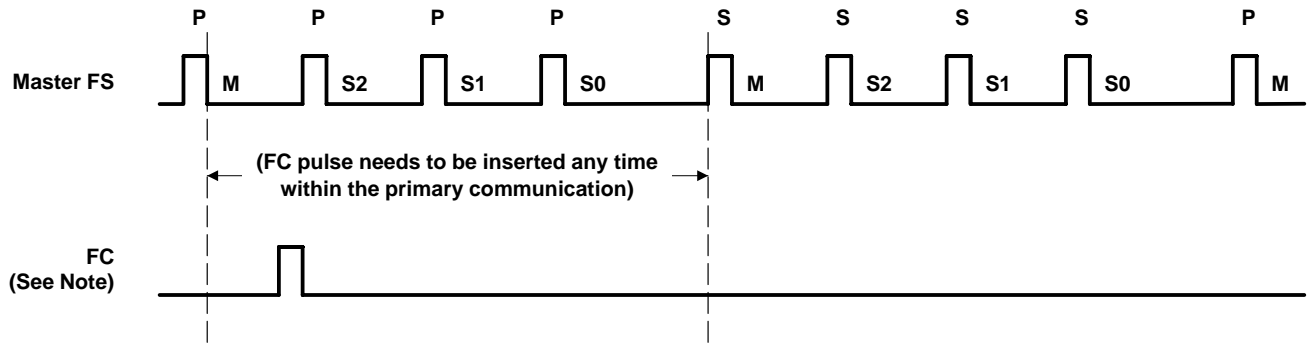

Figure 3–5. FS Output When Hardware Secondary Serial Communication Is Requested Only Once (No Slave)



- NOTES: A. FC of master device and slave devices should be connected together  
 B. Primary communication interval = 256 SCLKs if cascading devices < 5  
 C. Primary communication interval = 512 SCLKs if cascading devices > 4

**Figure 3–6. Output When Hardware Secondary Serial Communication Is Requested (Three Slaves)**

### 3.2.3 Software Secondary Serial Communication Request

The LSB of the DAC data within a primary transfer can request a secondary communication through bit D0 of control register 1 when the device is in the 15-bit mode.

For all serial communications, the most significant bit is transferred first. For a 16-bit ADC word and a 16-bit DAC word, D15 is the most significant bit and D0 is the least significant bit. For a 15-bit DAC data word in a primary communication, D15 is the most significant bit, D1 is the least significant bit. Bit D0 is then used for the secondary communication request control. All digital data values are in 2s-complement data format (see Figure 3–7).

If the data format is set to 16-bit word, all 16 bits are either ADC or DAC data, and secondary communication can only be requested by hardware (FC terminal), or control registers can be programmed by the direct configuration mode.

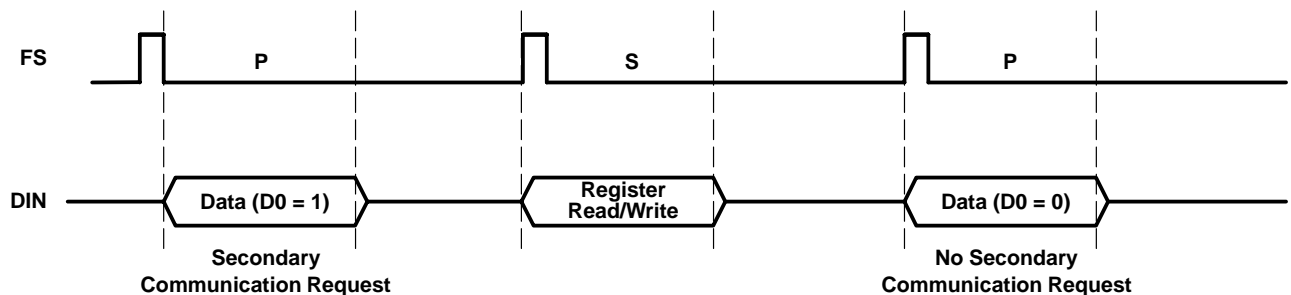

**Figure 3–7. FS Output During Software Secondary Serial Communication Request (No Slave)**

### 3.3 Direct Configuration Mode

For DSP applications that use continuous data transfer mode for autobuffering, or for DMA operations that do not have the capability to interfere with the data conversion channel by inserting the secondary communication, the TLV320AIC10s direct-configuration mode provides a flexible alternative to programming control registers through pin DCSI. The serial input to DCSI should normally be in a high state, start its valid data with a start bit of logic low, and pull high as a stop bit after transmission of the LSB. DCSI requires a pullup resistor for 3-state input. The AIC10 registers data bits on the falling edge of SCLK. Figure 3–8 shows a typical connection between the C54x and the AIC10 using DCSI for direct configuration of control registers. Figure 3–9 shows the timing diagram for the direct configuration mode.

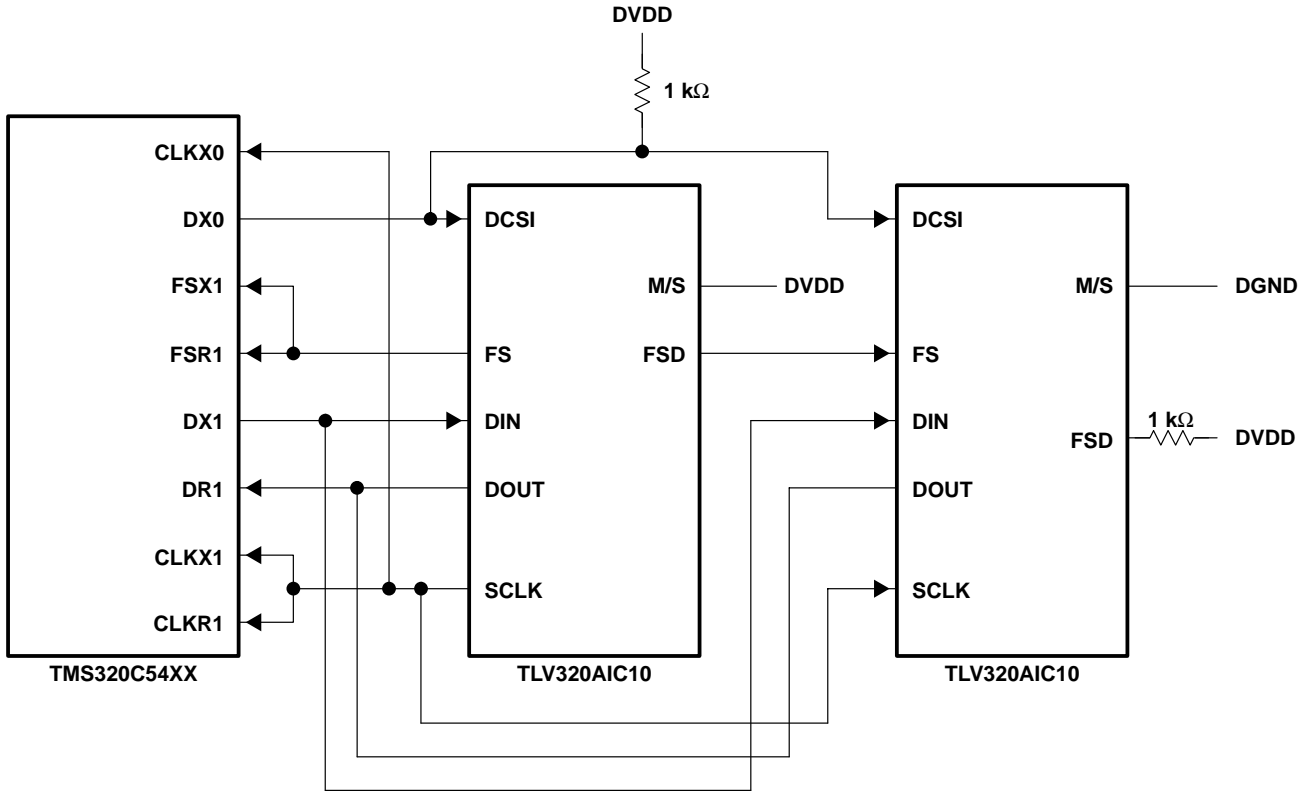

(a) Direct Configuration Between C54 and AIC10

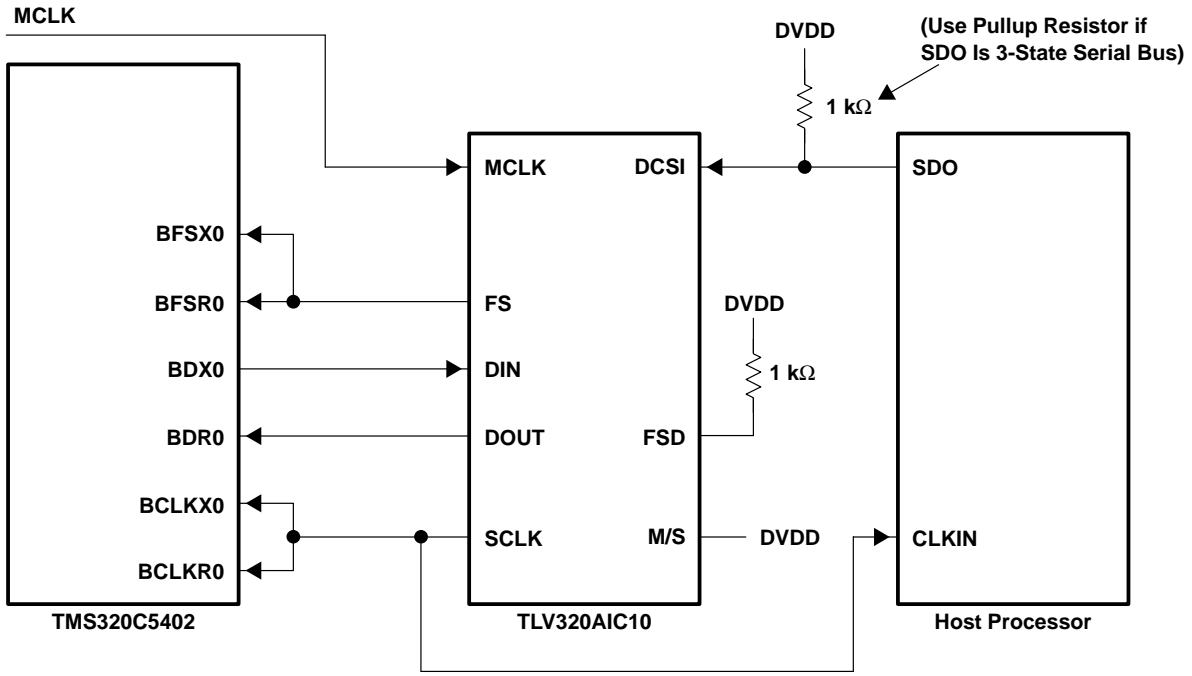

(b) Direct Configuration for Host Interface

Figure 3–8. Direct Configuration

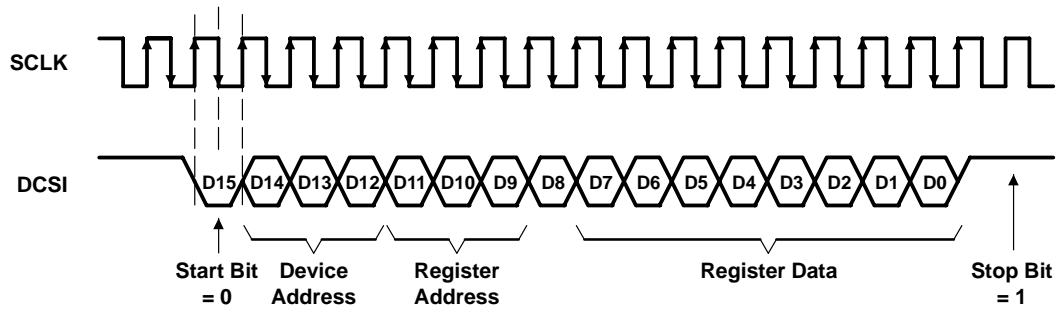

**Figure 3–9. Direct Configuration Mode Timing**

To program control register 1 of device 3, send data in with the following format through DCSI:

SB	Device Address			Register Address			X	Register Content							
0	0	1	1	0	0	1	x	x	x	x	x	x	x	x	x
D15				D0											

### 3.4 Continuous Data Transfer Mode

In continuous data transfer mode, the 16-bit converter data are transferred contiguously with no inactivity between bits. This mode is available in the stand-alone master with M1M0 = 00 (FS-pulse mode) and selected by setting bit D5 of control register 3 to 1. The secondary communication request is not allowed in this mode and therefore the direct configuration mode should be used to program the internal control registers. The continuous data transfer mode is designed to support the TI DSP McBSPs autobuffering unit (ABU) operation in which serial port interrupts are not generated with each word transferred to prevent CPUs ISR overheads.

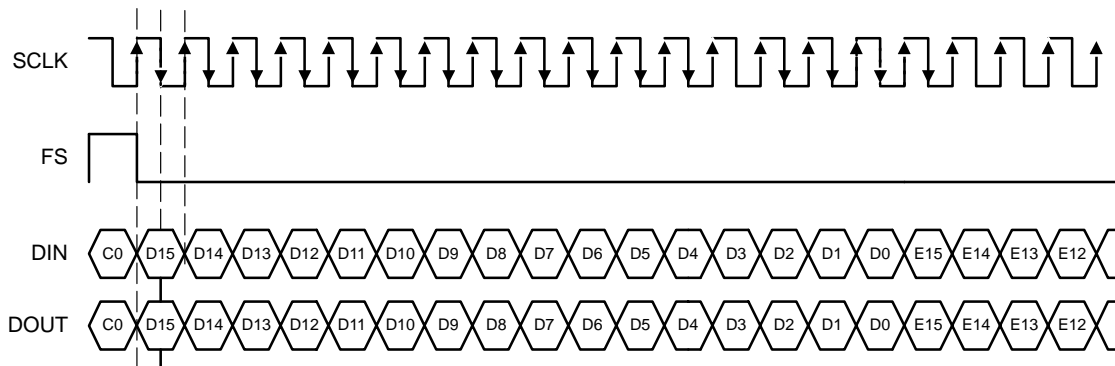

**Figure 3–10. Continuous Data Transfer Mode Timing**

### 3.5 DIN and DOUT Data Format

#### 3.5.1 Primary Serial Communication DIN and DOUT Data Format

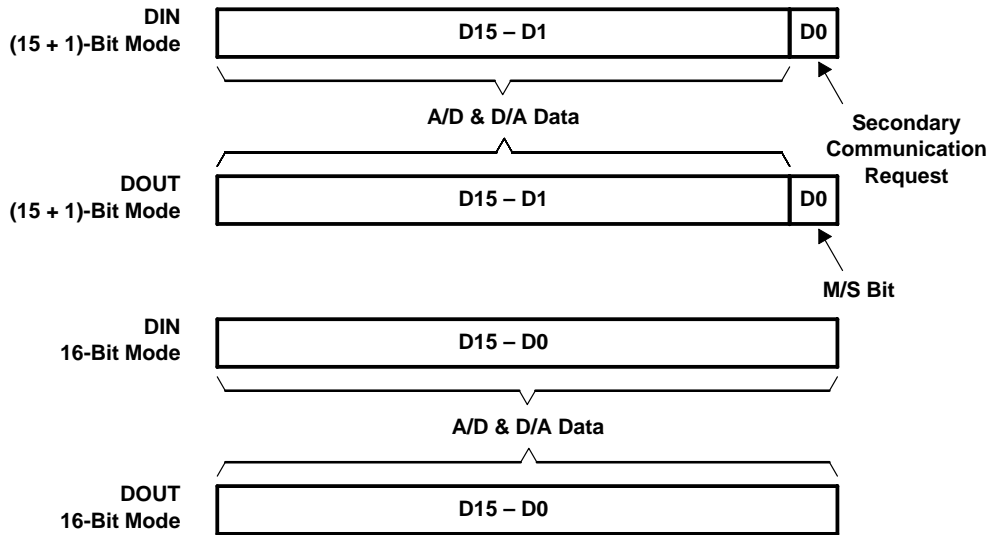

Figure 3–11. Primary Communication DIN and DOUT Data Format

#### 3.5.2 Secondary Serial Communication DIN and DOUT Data Format

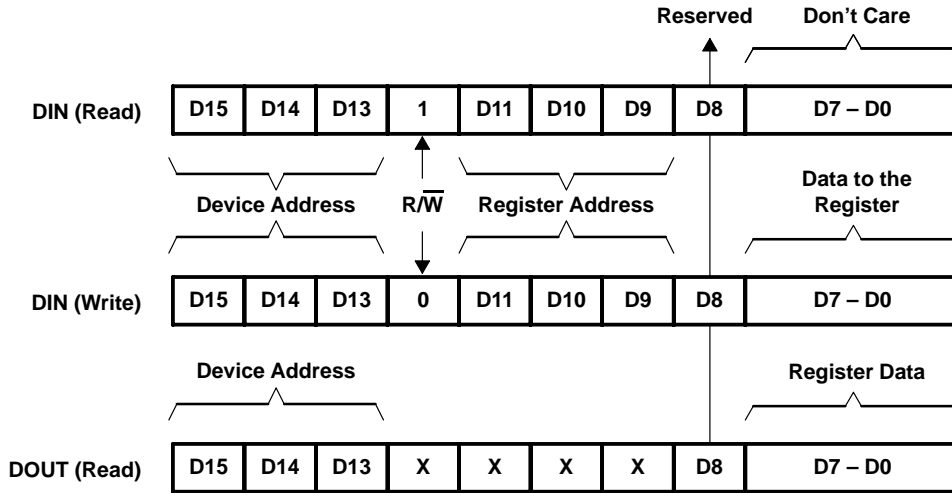

Figure 3–12. Secondary Communication DIN and DOUT Data Format

#### 3.5.3 Direct Configuration DCSI Data Format



Figure 3–13. Direct Communication DCSI Data Format

## 4 Specifications

### 4.1 Absolute Maximum Ratings Over Operating Free-Air Temperature Range (Unless Otherwise Noted)<sup>†</sup>

Supply voltage range, $DV_{DD}$ , $AV_{DD}$ (see Note 1)	-0.3 V to 7 V
Output voltage range, all digital output signals	-0.3V to $DV_{DD}+0.3$ V
Input voltage range, all digital input signals	-0.3V to $DV_{DD} +0.3$ V
Case temperature for 10 seconds: package	260°C
Operating free-air temperature range, $T_A$	-40°C to 85°C
Storage temperature range, $T_{Stg}$	-65°C to 150°C

<sup>†</sup> Stresses beyond those listed under “absolute maximum ratings” may cause permanent damage to the device. These are stress ratings only and functional operation of the device at these or any other conditions beyond those indicated under “recommended operating conditions” is not implied. Exposure to absolute-maximum-rated conditions for extended periods may affect device reliability.

NOTE 1: All voltage values are with respect to  $V_{SS}$ .

### 4.2 Recommended Operating Conditions

		MIN	NOM	MAX	UNIT
Analog supply voltage, $AV_{DD}$		3		5.5	V
Digital supply voltage, $DV_{DD}$		3		5.5	V
Analog signal peak-to-peak input voltage, $V_{I(ANALOG)}$ (5 V supply), single-ended			3		V
Analog signal peak-to-peak input voltage, $V_{I(ANALOG)}$ (3.3 V supply), single-ended			2		V
Differential output load resistance, $R_L$		600			$\Omega$
Output load capacitance, $C_L$				20	pF
Master clock	Divider N = Even			40	MHz
	Divider N = Odd	Max cascade = 4 devices		15	
		Max cascade = 8 devices		10	
ADC or DAC conversion rate				22	kHz
Operating free-air temperature, $T_A$		-40		85	°C

### 4.3 Electrical Characteristics Over Recommended Operating Free-Air Temperature Range, $AV_{DD} = 5$ V/3.3 V, $DV_{DD} = 5$ V/3.3 V

#### 4.3.1 Digital Inputs and Outputs, $F_s = 8$ kHz, Output Not Loaded

PARAMETER		TEST CONDITIONS	MIN	TYP	MAX	UNIT
$V_{OH}$	High-level output voltage, DOUT	$I_O = -360 \mu A$	2.4		$DV_{DD}+0.5$	V
$V_{OL}$	Low-level output voltage, DOUT	$I_O = 2$ mA	$DV_{SS}-0.5$		0.4	V
$I_{IH}$	High-level input current, any digital input	$V_{IH} = 5$ V			10	$\mu A$
$I_{IL}$	Low-level input current, any digital input	$V_{IL} = 0.6$ V			10	$\mu A$
$C_i$	Input capacitance			10		pF
$C_o$	Output capacitance			10		pF

### 4.3.2 ADC Path Filter, $F_s = 8$ kHz (see Note 2)

PARAMETER	TEST CONDITIONS	MIN	TYP	MAX	UNIT
Filter gain relative to gain at 1020 Hz	0 Hz to 300 Hz	-0.5		0.2	dB
	300 Hz to 3 kHz	-0.5		0.25	
	3.3 kHz	-0.5		0.3	
	3.6 kHz			-3	
	4 kHz			-35	
	$\geq 4.4$ kHz			-74	

NOTE 2: The filter gain outside of the passband is measured with respect to the gain at 1024 Hz. The analog input test signal is a sine wave with 0 dB =  $4 V_{I(PP)}$  as the reference level for the analog input signal. The pass band is 0 to 3600 Hz for an 8-kHz sample rate. This pass band scales linearly with the sample rate.

### 4.3.3 ADC Dynamic Performance, $F_s = 8$ kHz

#### 4.3.3.1 ADC Signal-to-Noise (see Note 3)

PARAMETER	TEST CONDITIONS	MIN	TYP	MAX	UNIT
SNR Signal-to-noise ratio	$V_I = -1$ dB	78	84		dB
	$V_I = -3$ dB	76	81		
	$V_I = -9$ dB	72	78		
	$V_I = -40$ dB	37	42		

NOTE 3: The test condition is a 1020-Hz input signal with an 8-kHz conversion rate. Input and output common mode is 2.5 V for 5-V supply, and 1.5-V for 3.3-V supply.

#### 4.3.3.2 ADC Signal-to-Distortion (see Note 3)

PARAMETER	TEST CONDITIONS	MIN	TYP	MAX	UNIT
THD Signal-to-total harmonic distortion	$V_I = -1$ dB	76	80		dB
	$V_I = -3$ dB	76	80		
	$V_I = -9$ dB	80	85		
	$V_I = -40$ dB	64	72		

NOTE 3: The test condition is a 1020-Hz input signal with an 8-kHz conversion rate. Input and output common mode is 2.5 V for 5-V supply, and 1.5-V for 3.3-V supply.

#### 4.3.3.3 ADC Signal-to-Distortion + Noise (see Note 3)

PARAMETER	TEST CONDITIONS	MIN	TYP	MAX	UNIT
THD+N Signal-to-total harmonic distortion + noise	$V_I = -1$ dB	76	80		dB
	$V_I = -3$ dB	74	79		
	$V_I = -9$ dB	72	78		
	$V_I = -40$ dB	38	43		

NOTE 3: The test condition is a 1020-Hz input signal with an 8-kHz conversion rate. Input and output common mode is 2.5 V for 5-V supply, and 1.5 V for 3.3-V supply.

### 4.3.4 ADC Channel Characteristics

PARAMETER		TEST CONDITIONS	MIN	TYP	MAX	UNIT
$V_{I(PP)}$	Peak-to-peak input voltage (differential)	Preamp gain = 0 dB			4	V
	Dynamic range	$V_I = -3$ dB		82		dB
	Intrachannel isolation			87		dB
$E_G$	Gain error	$V_I = -1$ dB at 1020 Hz		0.6		dB
$E_{O(ADC)}$	ADC converter offset error			±15		mV
CMRR	Common-mode rejection ratio at INM, INP or AUXM, AUXP	$V_I = -1$ dB at 1020 Hz		80		dB
	Idle channel noise (on-chip reference)	$V_{INP,INM} = 0$ V		25	70	$\mu$ Vrms
$R_i$	Input resistance	$T_A = 25^\circ\text{C}$		35		k $\Omega$
	Channel delay			$17/f_s$		s

### 4.3.5 DAC Path Filter, $F_s = 8$ kHz (see Note 4)

PARAMETER		TEST CONDITIONS	MIN	TYP	MAX	UNIT
Filter gain relative to gain at 1020 Hz		0 Hz to 300 Hz	-0.5		0.2	dB
		300 Hz to 3 kHz	-0.65		0.25	
		3.3 kHz	-0.75		0.3	
		3.6 kHz			-3	
		4 kHz			-35	
		$\geq 4.4$ kHz			-74	

NOTE 4: The filter gain outside of the passband is measured with respect to the gain at 1020 Hz. The input signal is the digital equivalent of a sine wave (digital full scale = 0 dB). The nominal differential DAC channel output with this input condition is  $6 V_{I(PP)}$ . The pass band is 0 to 3600 Hz for an 8-kHz sample rate. This pass band scales linearly with the conversion rate.

### 4.3.6 DAC Dynamic Performance

#### 4.3.6.1 DAC Signal-to-Noise When Load is 600 $\Omega$ (see Note 5)

PARAMETER		TEST CONDITIONS	MIN	TYP	MAX	UNIT
SNR	Signal-to-noise ratio	$V_I = 0$ dB	80	85		dB
		$V_I = -3$ dB	78	84		
		$V_I = -9$ dB	72	78		
		$V_I = -40$ dB	35	42		

NOTE 5: The test condition is the digital equivalent of a 1020-Hz input signal with an 8-kHz conversion rate. The test is measured at output of application schematic low-pass filter. The test is conducted in 16-bit mode.

#### 4.3.6.2 DAC Signal-to-Distortion when load is 600 $\Omega$ (see Note 5)

PARAMETER		TEST CONDITIONS	MIN	TYP	MAX	UNIT
THD	Signal-to-total harmonic distortion	$V_I = 0$ dB	70	77		dB
		$V_I = -3$ dB	78	85		
		$V_I = -9$ dB	78	85		
		$V_I = -40$ dB	62	66		

NOTE 5: The test condition is the digital equivalent of a 1020-Hz input signal with an 8-kHz conversion rate. The test is measured at output of application schematic low-pass filter. The test is conducted in 16-bit mode.

### 4.3.6.3 DAC Signal-to-Distortion + Noise When Load is 600 Ω (see Note 5)

PARAMETER		TEST CONDITIONS	MIN	TYP	MAX	UNIT
THD+N	Signal-to-total harmonic distortion + noise	$V_I = 0$ dB	70	77		dB
		$V_I = -3$ dB	73	78		
		$V_I = -9$ dB	70	78		
		$V_I = -40$ dB	35	42		

NOTE 5: The test condition is the digital equivalent of a 1020-Hz input signal with an 8-kHz conversion rate. The test is measured at output of application schematic low-pass filter. The test is conducted in 16-bit mode.

### 4.3.7 DAC Channel Characteristics

PARAMETER		TEST CONDITIONS	MIN	TYP	MAX	UNIT
Dynamic range		$V_I = 0$ dB at 1020 Hz		82		dB
Interchannel isolation				100		dB
$E_G$	Gain error, 0 dB	$V_O = 0$ dB at 1020 Hz		0.5		dB
Idle channel narrow band noise		0 kHz to 4 kHz, See Note 6		25	70	$\mu$ Vrms
$V_{OO}$	Output offset voltage at OUT (differential)	DIN = all zeros		30		mV
$V_O$	Analog output voltage	5 V	Differential with respect to common mode and full-scale digital input	-4	4	V
		3.3 V		-2.5	2.5	
Channel delay				$18/f_S$		

NOTE 6: The conversion rate is 8 kHz.

### 4.3.8 Op-Amp Interface (A1, A3, A4)

PARAMETER		TEST CONDITIONS	MIN	TYP	MAX	UNIT
$A_V$	Gain			100		
Input voltage range			0.5	$AV_{DD} - 0.5$		V
Input offset voltage				10		mV
Input offset current			0			mA
Output power				15		mW
SNR	Signal-to-noise ratio	Input frequency = 1020 Hz		90		dB
THD + N	Signal-to-total harmonic distortion + noise	Input frequency = 1020 Hz		90		dB
Unity-gain bandwidth		Open loop		10		MHz
Noise output voltage				30		$\mu$ Vrms

### 4.3.9 Power-Supply Rejection (see Note 7)

PARAMETER		TEST CONDITIONS	MIN	TYP	MAX	UNIT
$AV_{DD}$	Supply-voltage rejection ratio, analog supply	$f_j = 0$ to $f_S/2$		75		dB
$DV_{DD}$	Supply-voltage rejection ratio	DAC channel	$f_j = 0$ to 30 kHz	95		dB
		ADC channel		86		

NOTE 7: Power supply rejection measurements are made with both the ADC and the DAC channels idle and a 200-mV peak-to-peak signal applied to the appropriate supply.

## 4.3.10 Power Supply

### 4.3.10.1 Low-Power Mode (set control register bit D7 to 1)

PARAMETER		TEST CONDITIONS	MIN	TYP	MAX	UNIT
$P_D$	Power dissipation	All sections on, $V_{DD} = 3.3\text{ V}$		39.3		mW
$I_{DD}$ (analog)	Supply current	All sections on, $AV_{DD} = 3.3\text{ V}$		9.7		mA
		All sections on, $AV_{DD} = 5\text{ V}$		11.2		mA
$I_{DD}$ (digital)	Supply current	All sections on, $AV_{DD} = 3.3\text{ V}$		2.3		mA
		All sections on, $AV_{DD} = 5\text{ V}$		4.9		mA

### 4.3.10.2 Normal Operation

PARAMETER		TEST CONDITIONS	MIN	TYP	MAX	UNIT
$P_D$	Power dissipation	All sections on, $V_{DD} = 3.3\text{ V}$		48.5		mW
$I_{DD}$ (analog)	Supply current	All sections on, $AV_{DD} = 3.3\text{ V}$		13.6		mA
		All sections on, $AV_{DD} = 5\text{ V}$		14.8		mA
		Power down, $AV_{DD} = 3.3\text{ V}$		3		$\mu\text{A}$
		Power down, $AV_{DD} = 5\text{ V}$		11		$\mu\text{A}$
$I_{DD}$ (digital)	Supply current	All sections on, $AV_{DD} = 3.3\text{ V}$		1.1		mA
		All sections on, $AV_{DD} = 5\text{ V}$		2.3		mA
		Power down, $AV_{DD} = 3.3\text{ V}$		0.15		mA
		Power down, $AV_{DD} = 5\text{ V}$		0.6		mA

## 4.4 Timing Requirements (see *Parameter Measurement Information*)

### 4.4.1 Master Mode Timing Requirements

PARAMETERS		TEST CONDITIONS	MIN	TYP	MAX	UNIT
$t_{d(1)}$	Delay time, SCLK $\uparrow$ to FS $\downarrow$	$C_L = 20\text{ pF}$			5	ns
$t_{d(2)}$	Delay time, SCLK $\uparrow$ to DOUT				15	ns
$t_{su}$	Setup time, DIN, before SCLK low			5		ns
$t_h$	Hold time, DIN, after SCLK high			1/2T+5		ns
$t_{en}$	Enable time, FS $\downarrow$ to DOUT			1/2T+5		ns
$t_{dis}$	Disable time, FS $\uparrow$ to DOUT Hi-Z			5		ns
$t_{d(3)}$	Delay time, MCLK $\downarrow$ to SCLK $\uparrow$				10	ns
$t_{d(CH-FL)}$	Delay time, SCLK high to FS/FSD high (see Figure 5-1)				5	ns
$t_{d(CH-FH)}$	Delay time, SCLK high to FS/FSD high				5	ns
$t_{w(H)}$	Pulse duration, MCLK high			12.5		ns
$t_{w(L)}$	Pulse duration, MCLK low			12.5		ns



## 5 Parameter Measurement Information

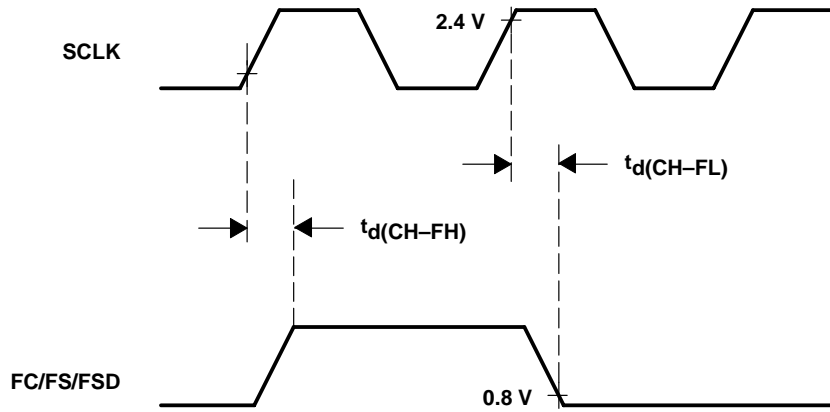

Figure 5-1. FC, FS, and FSD Timing

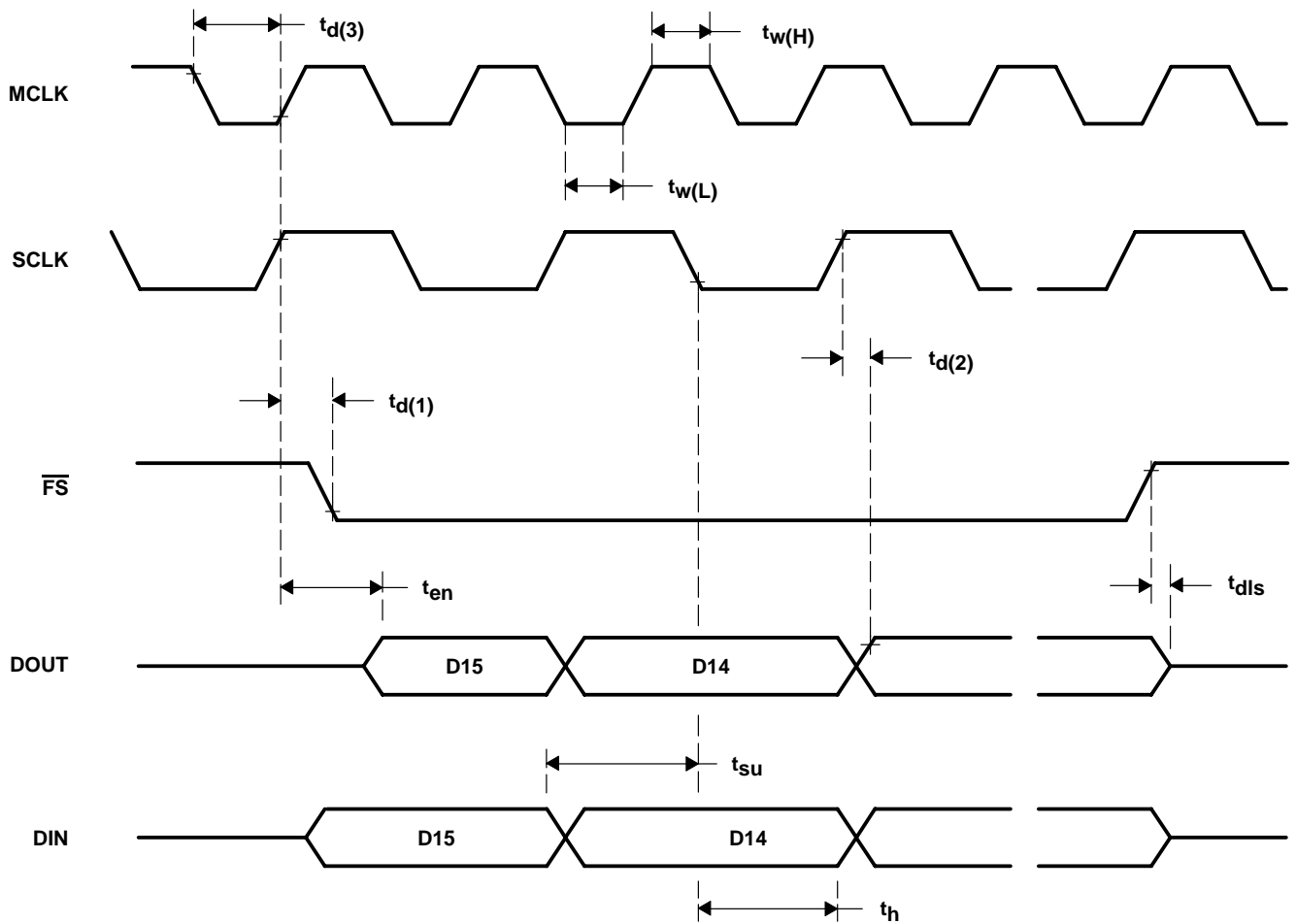
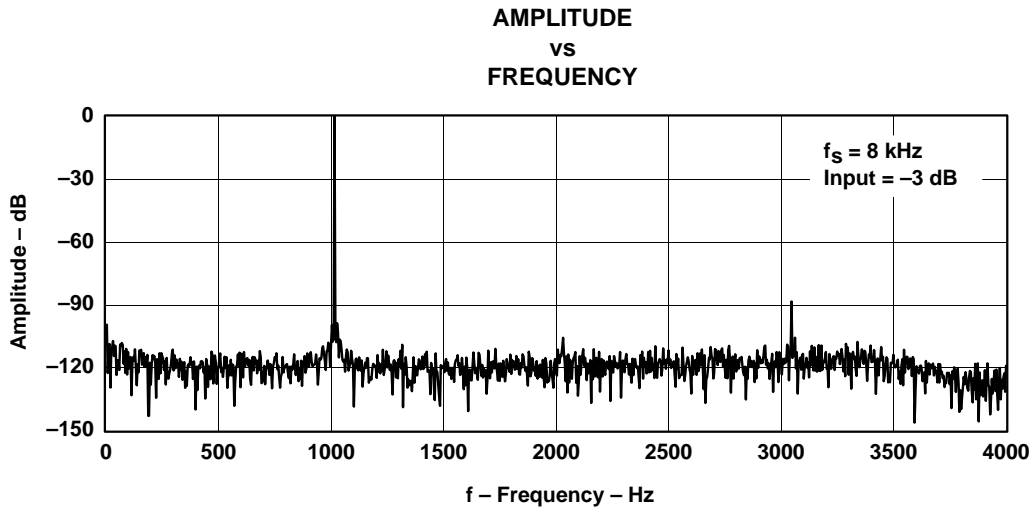
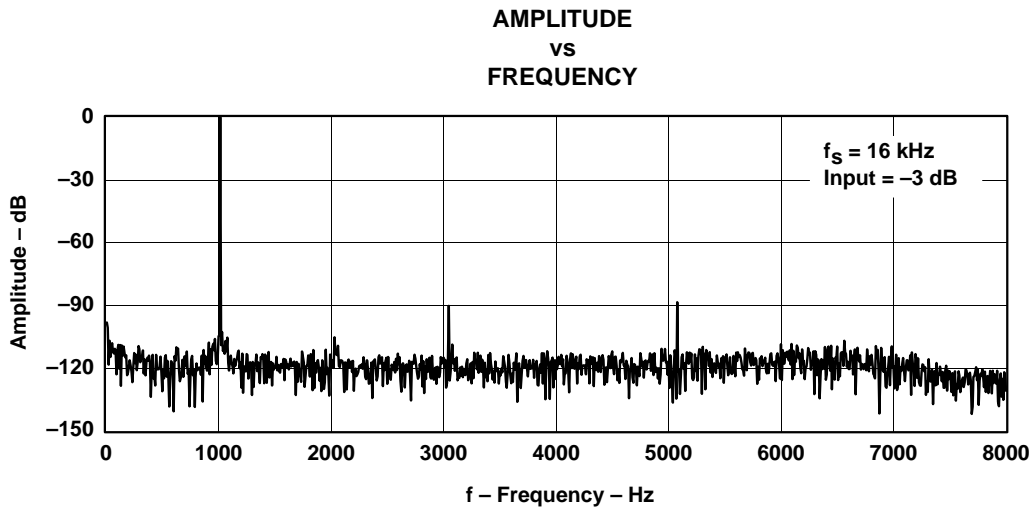

Figure 5-2. Serial Communication Timing



**Figure 5-3. FFT-ADC Channel**



**Figure 5-4. FFT-ADC Channel**

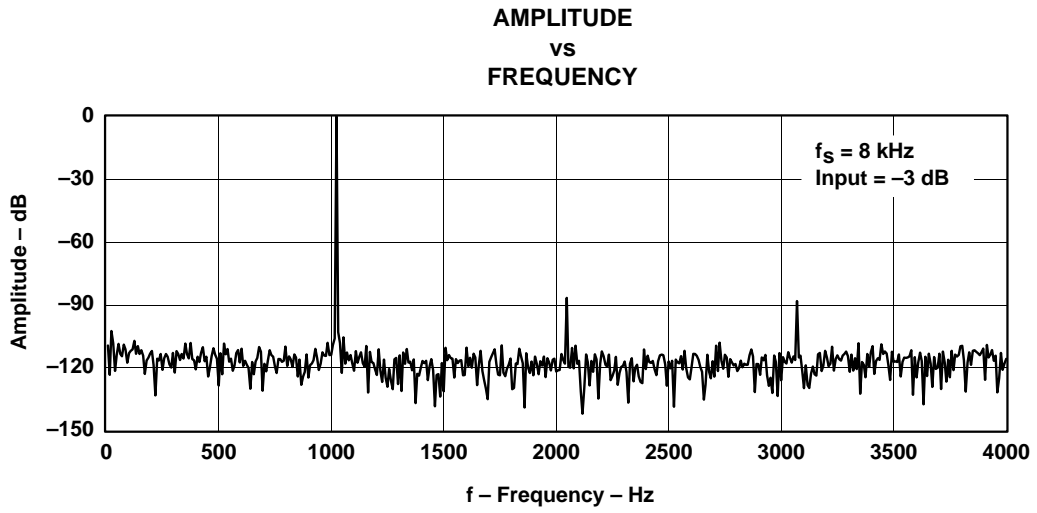

Figure 5-5. FFT-DAC Channel

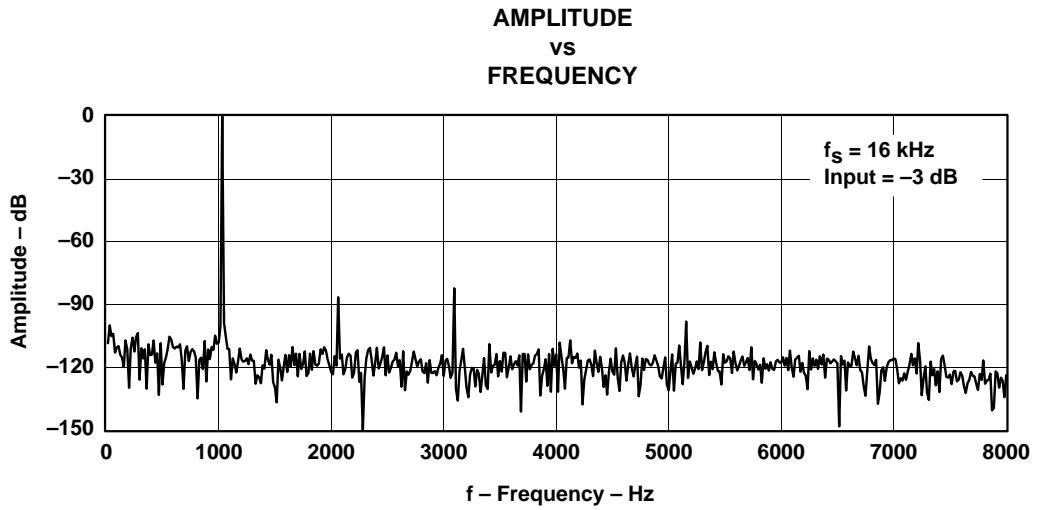
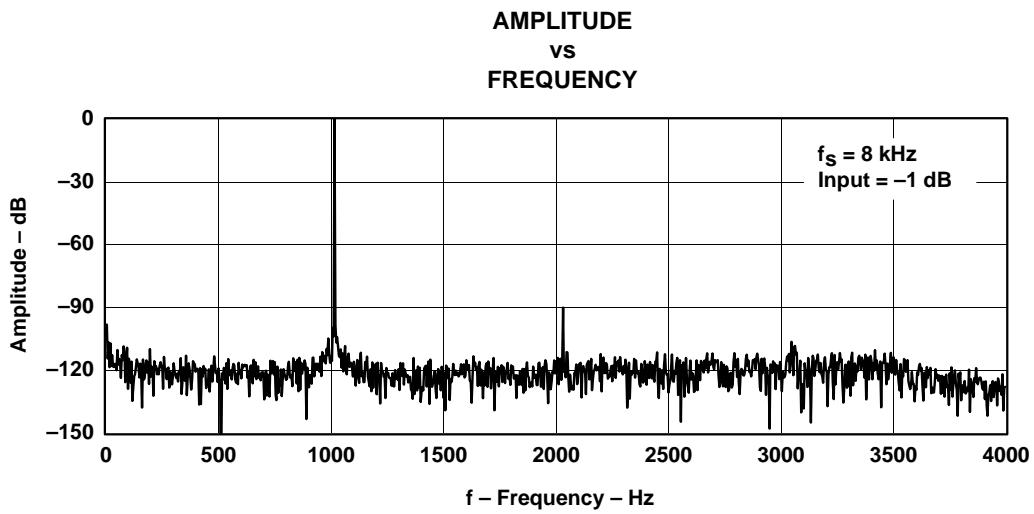
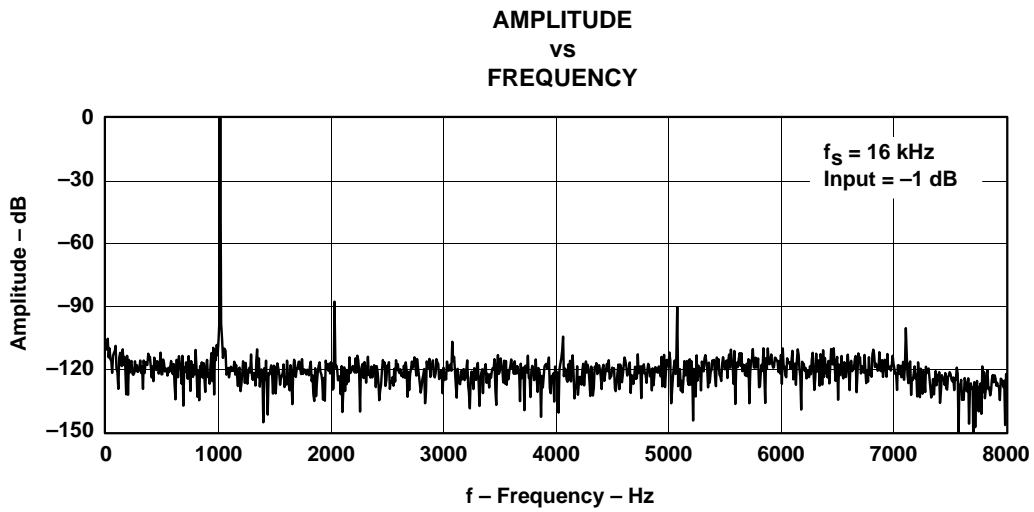

Figure 5-6. FFT-DAC Channel



**Figure 5-7. FFT-ADC Channel**



**Figure 5-8. FFT-ADC Channel**

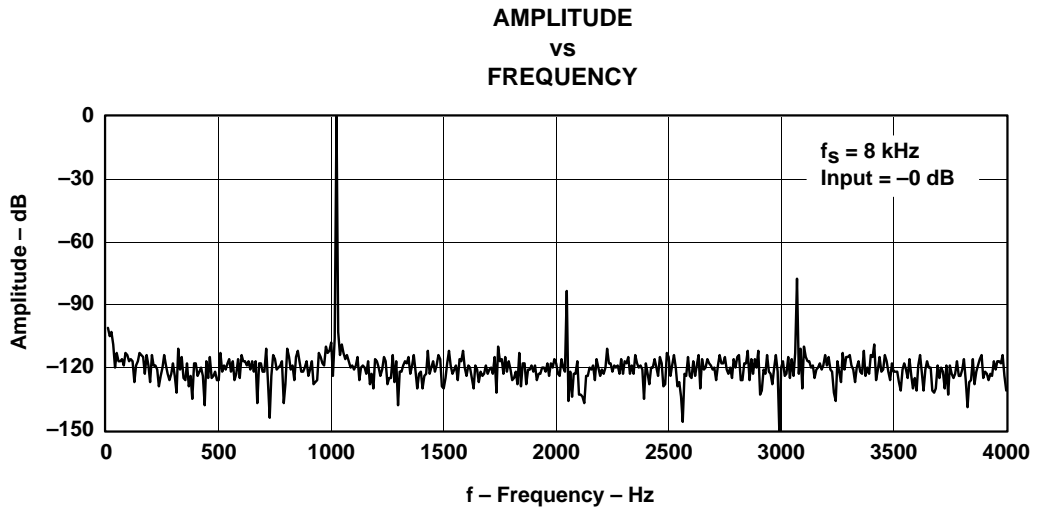

**Figure 5-9. FFT-DAC Channel**

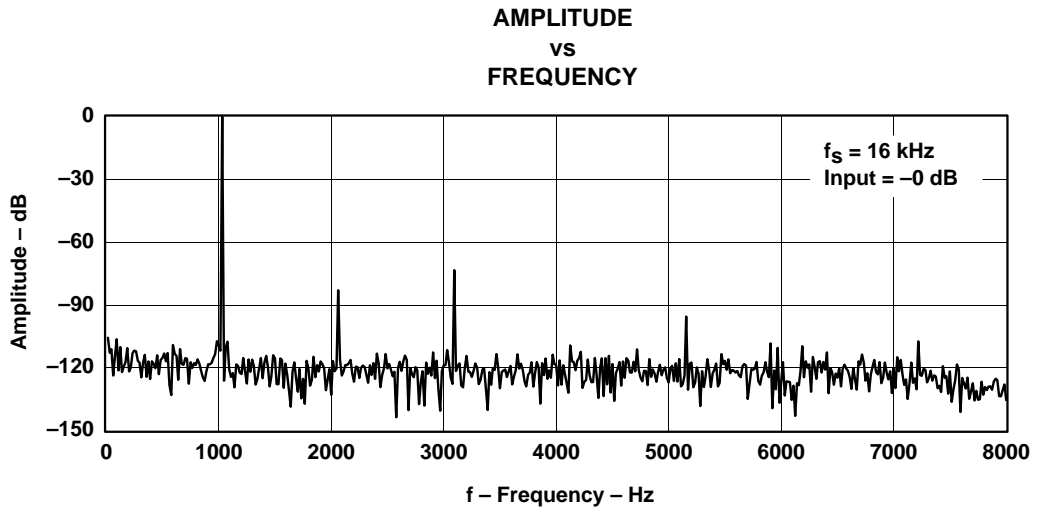

**Figure 5-10. FFT-DAC Channel**



## 6 Mechanical Information

PFB (S-PQFP-G48)

PLASTIC QUAD FLATPACK

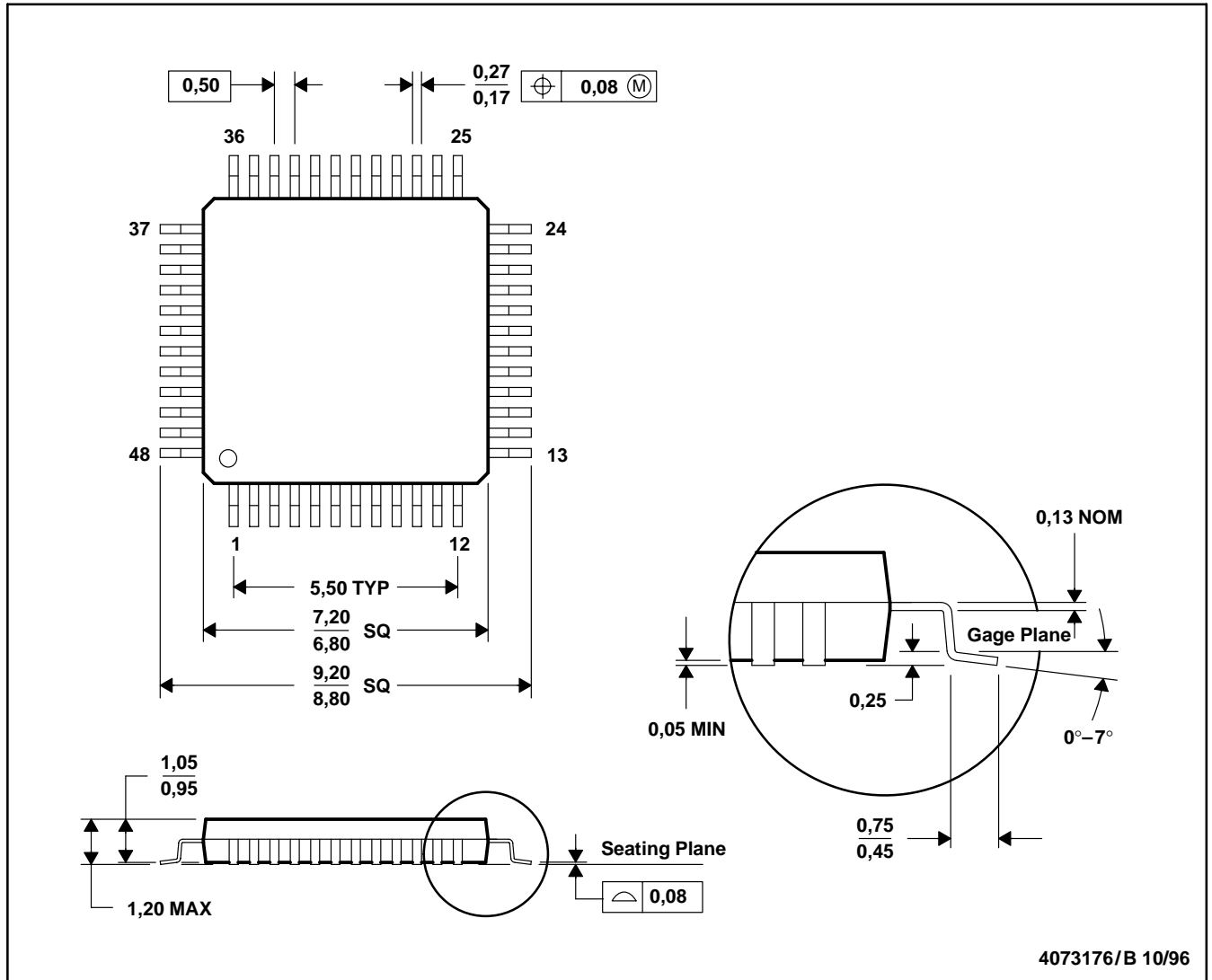

- NOTES: A. All linear dimensions are in millimeters.  
 B. This drawing is subject to change without notice.  
 C. Falls within JEDEC MS-026

GQE (S-PBGA-N80)

PLASTIC BALL GRID ARRAY

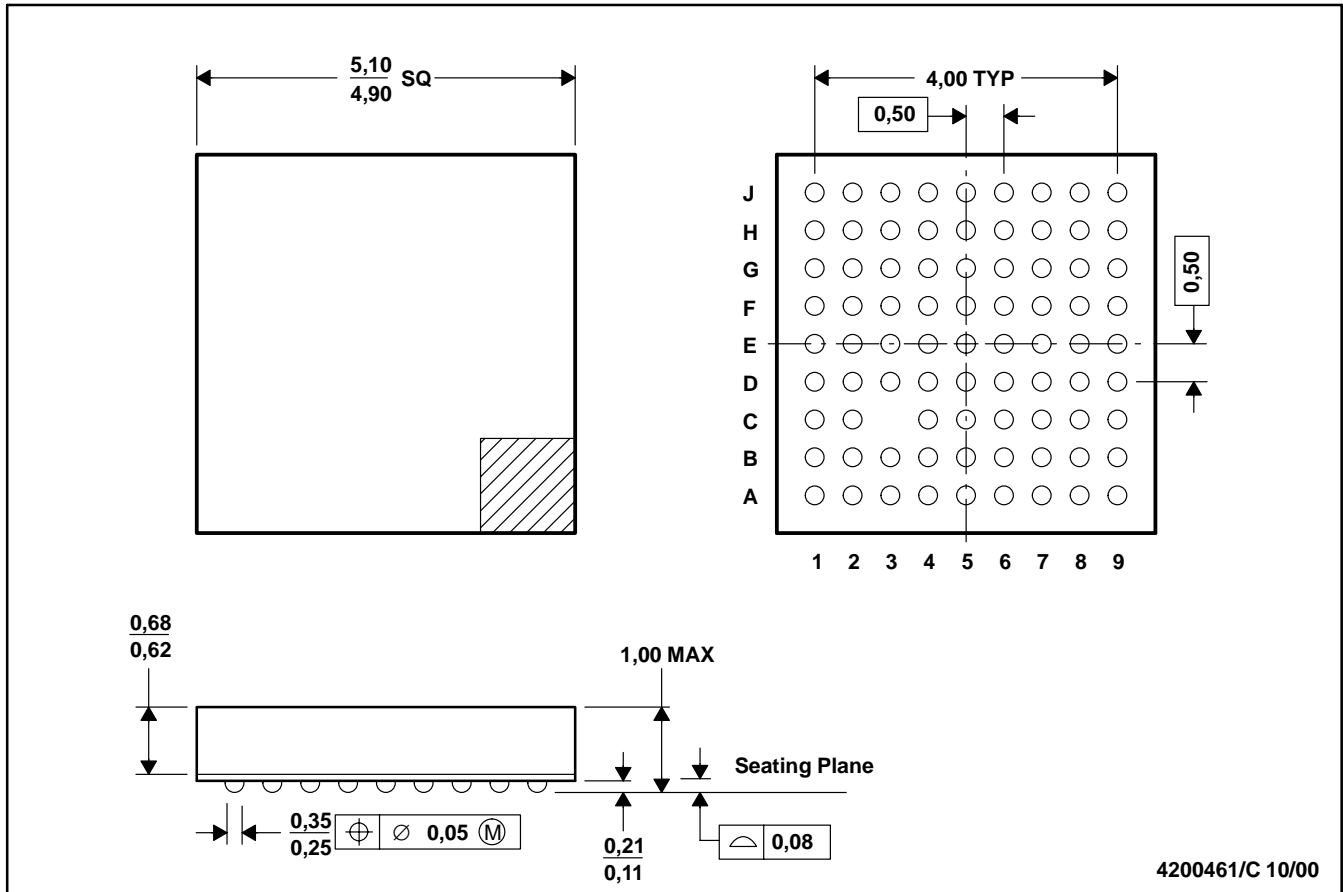

- NOTES: A. All linear dimensions are in millimeters.  
 B. This drawing is subject to change without notice.  
 C. MicroStar Junior™ BGA configuration  
 D. Falls within JEDEC MO-225

MicroStar Junior is a trademark of Texas Instruments.

## Appendix A Register Set

Bits D15 through D13 represent the device address in the cascade set by the automatic cascade detection described in Section 2.1.13. In cascading, the master is the device directly connected to the DSP. For example, if there are four devices in the cascade, as shown in row 4 of Table A-1 and in Section 2.7.5, the device address D15-D13 of the master will have a binary value of *011*. The other three slaves addresses are *010*, *001*, and *000*, corresponding to their positions in the cascade. The device address for a stand-alone device is always *000*. Bits D11 through D8 comprise the address of the register that is written with data carried in D7 through D0. D12 determines a read or write cycle to the addressed register; a low selects a write cycle.

The following table shows the register map.

REGISTER MAP															
D15	D14	D13	D12	D11	D10	D9	D8	D7	D6	D5	D4	D3	D2	D1	D0
Device Address			RW	Register Address			X	Control Register Content							

**Table A-1. Device Address**

REGISTER MAP															
D15	D14	D13	D12	D11	D10	D9	D8	D7	D6	D5	D4	D3	D2	D1	D0
Device Address			R/W	Register Address			X	Register Content							

# Devices in Cascade	DEVICE ADDRESS (D15-D13)							
	Device 7	Device 6	Device 5	Device 4	Device 3	Device 2	Device 1	Device 0
1								000
2							001	000
3						010	001	000
4					011	010	001	000
5				100	011	010	001	000
6			101	100	011	010	001	000
7		110	101	100	011	010	001	000
8	111	110	101	100	011	010	001	000

**Table A-2. Register Address**

REGISTER NO.	D11	D10	D9	REGISTER NAME
0	0	0	0	No operation
1	0	0	1	Control 1
2	0	1	0	Control 2
3	0	1	1	Control 3
4	1	0	0	Control 4

## A.1 Control Register 1

**Table A–3. Register Map**

D7	D6	D5	D4	D3	D2	D1	D0	DESCRIPTION
ovf	–	–	–	–	–	–	–	Decimator FIR overflow flag
–	1	–	–	–	–	–	–	Enable HYBRID receiver/MIC amp (A1)
–	0	–	–	–	–	–	–	Disable HYBRID/MIC amp (A1)
–	–	1	–	–	–	–	–	Bypass antialiasing filter
–	–	0	–	–	–	–	–	Enable antialiasing filter
–	–	–	1	–	–	–	–	Select AUXP and AUXM for ADC
–	–	–	0	–	–	–	–	Select INP and INM for ADC
–	–	–	–	1	–	–	–	Software reset
–	–	–	–	0	–	–	–	Default
–	–	–	–	–	1	–	–	Bypass decimation/interpolation FIR filter
–	–	–	–	–	0	–	–	Normal operation with FIR filter
–	–	–	–	–	–	1	–	Enable HYBRID transmitter/MIC amps (A3,A4)
–	–	–	–	–	–	0	–	Disable HYBRID transmitter/MIC amps (A3,A4)
–	–	–	–	–	–	–	1	16-bit data format for DAC
–	–	–	–	–	–	–	0	15-bit data + LSB format for DAC

Default value: 00000000

NOTE: A software reset is a one-shot operation and this bit is cleared to 0 after reset. It is not necessary to write a 0 to end the master reset operation.

Enabling the D6 bit automatically selects AUX channel for the ADC input.

## A.2 Control Register 2

**Table A–4. Control Register 2**

D7	D6	D5	D4	D3	D2	D1	D0	DIVIDE VALUE
1	–	–	–	–	–	–	–	Low-power operation mode
0	–	–	–	–	–	–	–	Normal operation mode
–	1	–	–	–	–	–	–	S–D modulator stops
–	0	–	–	–	–	–	–	S–D modulator runs
–	–	R	–	–	–	–	–	Reserved
–	–	–	1	1	1	1	1	Frequency Divider N = 31
–	–	–	•				•	
–	–	–	•				•	
–	–	–	•				•	
–	–	–	0	0	0	0	1	Frequency Divider N = 1
–	–	–	0	0	0	0	0	Frequency Divider N = 32

Default value: 00000000

NOTE: The serial port interface always gluelessly works with the DSP. The following modes will not produce 50% duty cycle SCLK:

1. If the number of devices in cascade >4 and N is an odd number (i.e., N = 1, 3, 5,...)
2. If the number of devices in cascade ≤4, FIR is bypassed, and N ≠ 4, 8, 12, 16, 20, 24, 28, 32

### A.3 Control Register 3

**Table A-5. Control Register 3**

D7	D6	D5	D4	D3	D2	D1	D0	DESCRIPTION
0	0	–	–	–	–	–	–	Default
0	1	–	–	–	–	–	–	Analog loopback enabled
1	0	–	–	–	–	–	–	Digital loopback enabled
1	1	–	–	–	–	–	–	Event-monitor mode enabled (write cycle only)
–	–	1	–	–	–	–	–	Continuous data-transfer mode (master only)
–	–	0	–	–	–	–	–	Default
–	–	–	1	–	–	–	–	FLAG output = D3
–	–	–	0	–	–	–	–	FLAG output = secondary communication flag
–	–	–		F	–	–	–	FLAG value
–	–	–	–	–	0	0	–	Default
–	–	–	–	–	0	1	–	Disable ADC channel
–	–	–	–	–	1	0	–	Disable DAC channel
–	–	–	–	–	1	1	–	Software power-down mode
–	–	–	–	–	–	–	1	16-bit data format for ADC
–	–	–	–	–	–	–	0	Not 16-bit data format for ADC

Default value: 00000000

## A.4 Control Register 4

**Table A–6. Control Register 4**

D7	D6	D5	D4	D3	D2	D1	D0	DESCRIPTION
1	1	1	1	–	–	–	–	ADC input PGA gain = MUTE
1	1	1	0	–	–	–	–	ADC input PGA gain = 24 dB
1	1	0	1	–	–	–	–	ADC input PGA gain = 18 dB
1	1	0	0	–	–	–	–	ADC input PGA gain = 12 dB
1	0	1	1	–	–	–	–	ADC input PGA gain = 9 dB
1	0	1	0	–	–	–	–	ADC input PGA gain = 6 dB
1	0	0	1	–	–	–	–	ADC input PGA gain = 3 dB
1	0	0	0	–	–	–	–	ADC input PGA gain = –3 dB
0	1	1	1	–	–	–	–	ADC input PGA gain = –6 dB
0	1	1	0	–	–	–	–	ADC input PGA gain = –9 dB
0	1	0	1	–	–	–	–	ADC input PGA gain = –12 dB
0	1	0	0	–	–	–	–	ADC input PGA gain = –18 dB
0	0	1	1	–	–	–	–	ADC input PGA gain = –24 dB
0	0	1	0	–	–	–	–	ADC input PGA gain = –30 dB
0	0	0	1	–	–	–	–	ADC input PGA gain = –36 dB
0	0	0	0	–	–	–	–	ADC input PGA gain = 0 dB
–	–	–	–	1	1	1	1	DAC output PGA gain = MUTE
–	–	–	–	1	1	1	0	DAC output PGA gain = 24 dB
–	–	–	–	1	1	0	1	DAC output PGA gain = 18 dB
–	–	–	–	1	1	0	0	DAC output PGA gain = 12 dB
–	–	–	–	1	0	1	1	DAC output PGA gain = 9 dB
–	–	–	–	1	0	1	0	DAC output PGA gain = 6 dB
–	–	–	–	1	0	0	1	DAC output PGA gain = 3 dB
–	–	–	–	1	0	0	0	DAC output PGA gain = –3 dB
–	–	–	–	0	1	1	1	DAC output PGA gain = –6 dB
–	–	–	–	0	1	1	0	DAC output PGA gain = –9 dB
–	–	–	–	0	1	0	1	DAC output PGA gain = –12 dB
–	–	–	–	0	1	0	0	DAC output PGA gain = –18 dB
–	–	–	–	0	0	1	1	DAC output PGA gain = –24 dB
–	–	–	–	0	0	1	0	DAC output PGA gain = –30 dB
–	–	–	–	0	0	0	1	DAC output PGA gain = –36 dB
–	–	–	–	0	0	0	0	DAC output PGA gain = 0 dB

Default value: 00000000

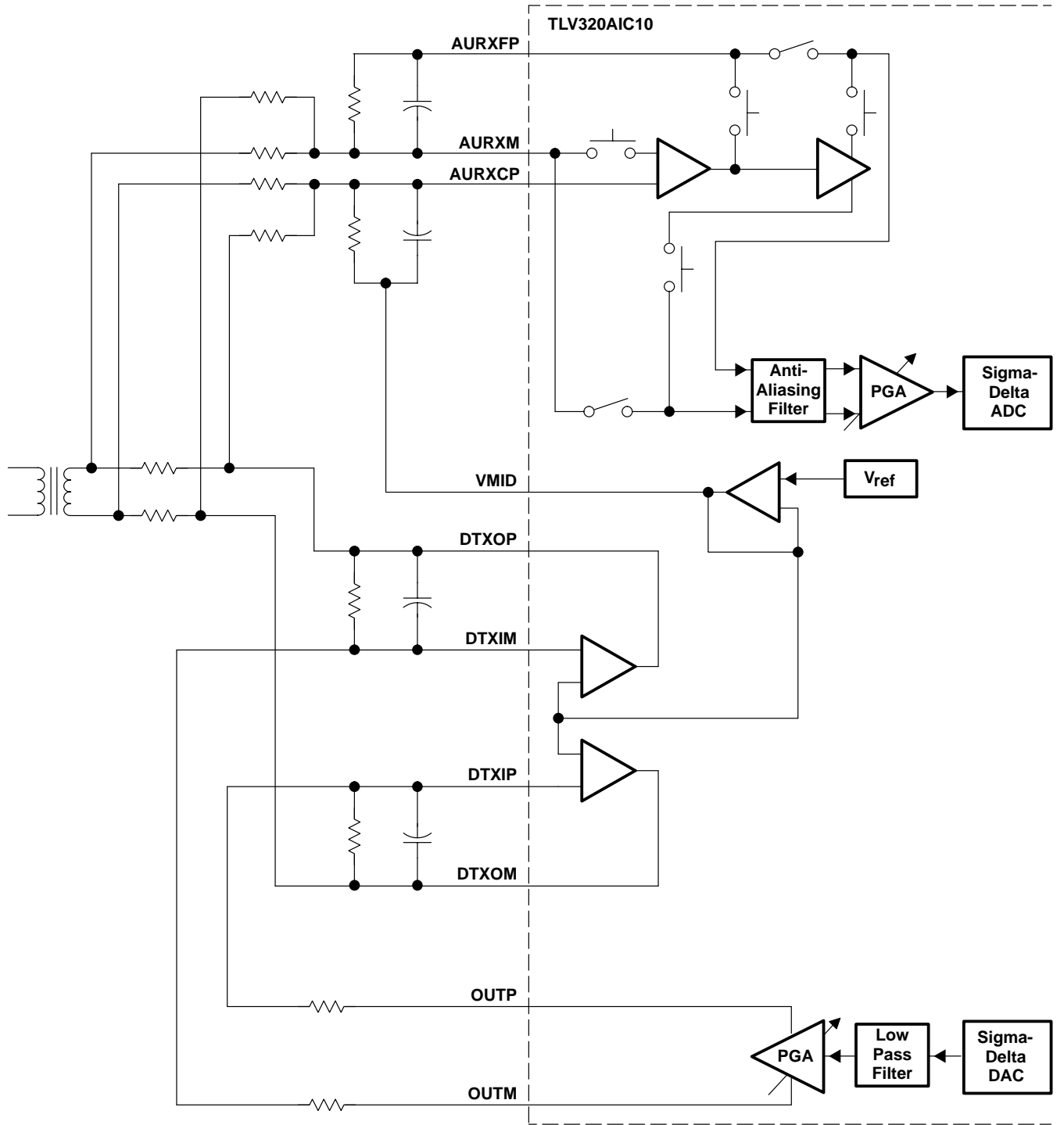

Figure A-1. Differential Configuration for Hybrid Connection

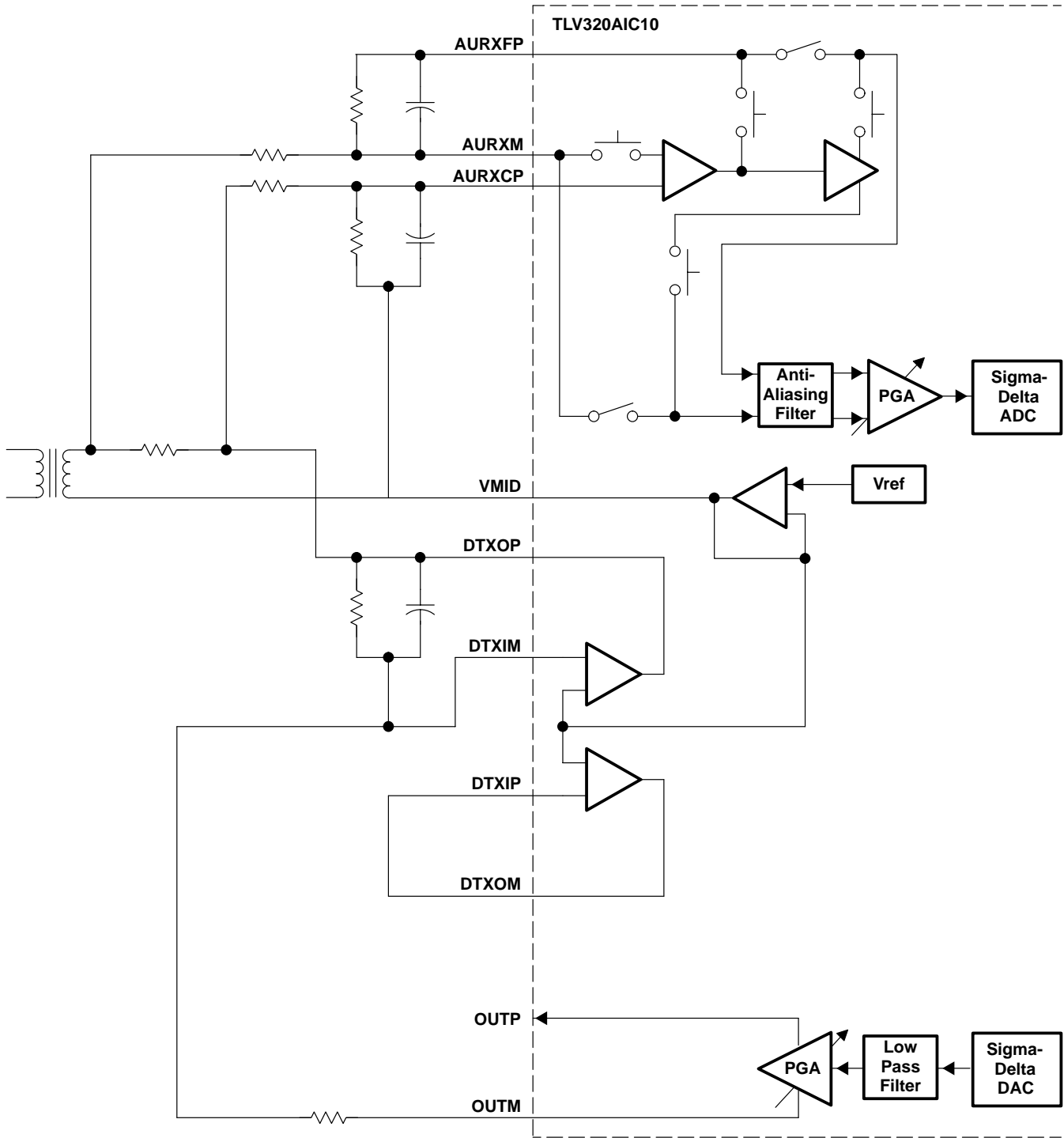

Figure A-2. Single-Ended Configuration of Hybrid Connection

## PACKAGING INFORMATION

Orderable Device	Status (1)	Package Type	Package Drawing	Pins	Package Qty	Eco Plan (2)	Lead finish/ Ball material (6)	MSL Peak Temp (3)	Op Temp (°C)	Device Marking (4/5)	Samples
TLV320AIC10CPF8	ACTIVE	TQFP	PFB	48	250	RoHS & Green	NIPDAU	Level-2-260C-1 YEAR	0 to 70	320AIC10C	<a href="#">Samples</a>
TLV320AIC10IPFB	ACTIVE	TQFP	PFB	48	250	RoHS & Green	NIPDAU	Level-2-260C-1 YEAR	-40 to 85	320AIC10I	<a href="#">Samples</a>
TLV320AIC10IPFBG4	ACTIVE	TQFP	PFB	48	250	RoHS & Green	NIPDAU	Level-2-260C-1 YEAR	-40 to 85	320AIC10I	<a href="#">Samples</a>

(1) The marketing status values are defined as follows:

**ACTIVE:** Product device recommended for new designs.

**LIFEBUY:** TI has announced that the device will be discontinued, and a lifetime-buy period is in effect.

**NRND:** Not recommended for new designs. Device is in production to support existing customers, but TI does not recommend using this part in a new design.

**PREVIEW:** Device has been announced but is not in production. Samples may or may not be available.

**OBSOLETE:** TI has discontinued the production of the device.

(2) **RoHS:** TI defines "RoHS" to mean semiconductor products that are compliant with the current EU RoHS requirements for all 10 RoHS substances, including the requirement that RoHS substance do not exceed 0.1% by weight in homogeneous materials. Where designed to be soldered at high temperatures, "RoHS" products are suitable for use in specified lead-free processes. TI may reference these types of products as "Pb-Free".

**RoHS Exempt:** TI defines "RoHS Exempt" to mean products that contain lead but are compliant with EU RoHS pursuant to a specific EU RoHS exemption.

**Green:** TI defines "Green" to mean the content of Chlorine (Cl) and Bromine (Br) based flame retardants meet JS709B low halogen requirements of <=1000ppm threshold. Antimony trioxide based flame retardants must also meet the <=1000ppm threshold requirement.

(3) MSL, Peak Temp. - The Moisture Sensitivity Level rating according to the JEDEC industry standard classifications, and peak solder temperature.

(4) There may be additional marking, which relates to the logo, the lot trace code information, or the environmental category on the device.

(5) Multiple Device Markings will be inside parentheses. Only one Device Marking contained in parentheses and separated by a "~" will appear on a device. If a line is indented then it is a continuation of the previous line and the two combined represent the entire Device Marking for that device.

(6) Lead finish/Ball material - Orderable Devices may have multiple material finish options. Finish options are separated by a vertical ruled line. Lead finish/Ball material values may wrap to two lines if the finish value exceeds the maximum column width.

**Important Information and Disclaimer:** The information provided on this page represents TI's knowledge and belief as of the date that it is provided. TI bases its knowledge and belief on information provided by third parties, and makes no representation or warranty as to the accuracy of such information. Efforts are underway to better integrate information from third parties. TI has taken and continues to take reasonable steps to provide representative and accurate information but may not have conducted destructive testing or chemical analysis on incoming materials and chemicals. TI and TI suppliers consider certain information to be proprietary, and thus CAS numbers and other limited information may not be available for release.

In no event shall TI's liability arising out of such information exceed the total purchase price of the TI part(s) at issue in this document sold by TI to Customer on an annual basis.

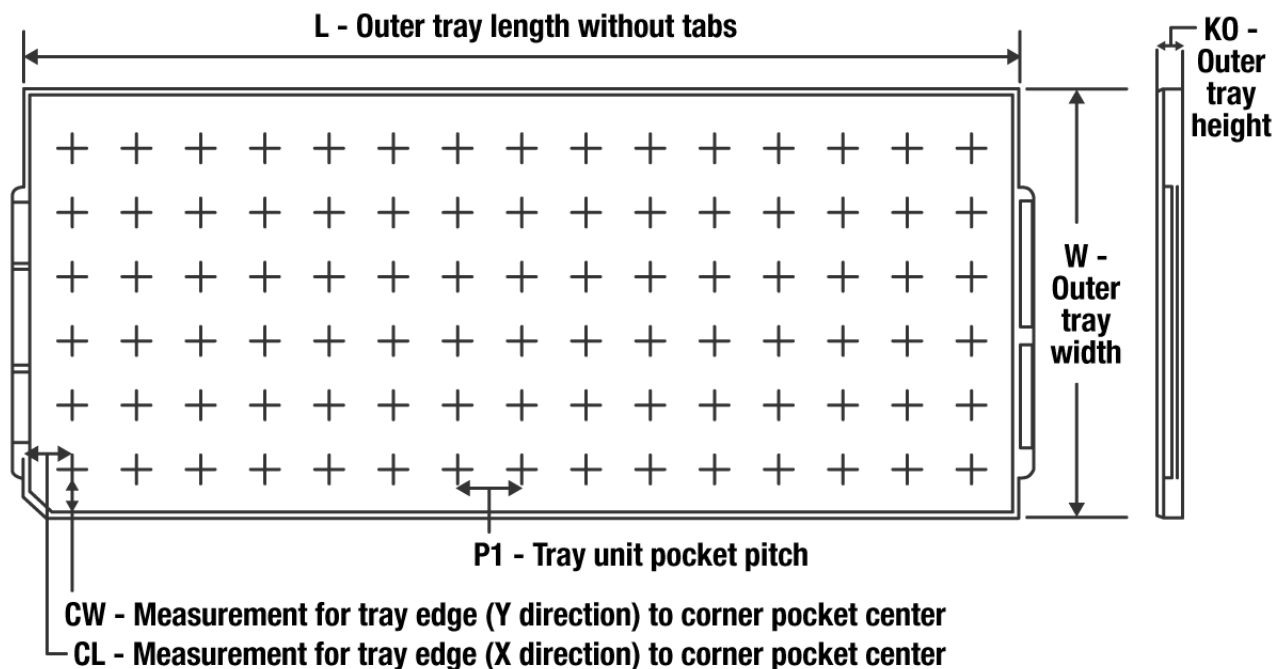
**TRAY**

Chamfer on Tray corner indicates Pin 1 orientation of packed units.

\*All dimensions are nominal

Device	Package Name	Package Type	Pins	SPQ	Unit array matrix	Max temperature (°C)	L (mm)	W (mm)	K0 (µm)	P1 (mm)	CL (mm)	CW (mm)
TLV320AIC10CPFB	PFB	TQFP	48	250	10 x 25	150	315	135.9	7620	12.2	11.1	11.25
TLV320AIC10IPFB	PFB	TQFP	48	250	10 x 25	150	315	135.9	7620	12.2	11.1	11.25
TLV320AIC10IPFBG4	PFB	TQFP	48	250	10 x 25	150	315	135.9	7620	12.2	11.1	11.25

## IMPORTANT NOTICE AND DISCLAIMER

TI PROVIDES TECHNICAL AND RELIABILITY DATA (INCLUDING DATA SHEETS), DESIGN RESOURCES (INCLUDING REFERENCE DESIGNS), APPLICATION OR OTHER DESIGN ADVICE, WEB TOOLS, SAFETY INFORMATION, AND OTHER RESOURCES "AS IS" AND WITH ALL FAULTS, AND DISCLAIMS ALL WARRANTIES, EXPRESS AND IMPLIED, INCLUDING WITHOUT LIMITATION ANY IMPLIED WARRANTIES OF MERCHANTABILITY, FITNESS FOR A PARTICULAR PURPOSE OR NON-INFRINGEMENT OF THIRD PARTY INTELLECTUAL PROPERTY RIGHTS.

These resources are intended for skilled developers designing with TI products. You are solely responsible for (1) selecting the appropriate TI products for your application, (2) designing, validating and testing your application, and (3) ensuring your application meets applicable standards, and any other safety, security, regulatory or other requirements.

These resources are subject to change without notice. TI grants you permission to use these resources only for development of an application that uses the TI products described in the resource. Other reproduction and display of these resources is prohibited. No license is granted to any other TI intellectual property right or to any third party intellectual property right. TI disclaims responsibility for, and you will fully indemnify TI and its representatives against, any claims, damages, costs, losses, and liabilities arising out of your use of these resources.

TI's products are provided subject to [TI's Terms of Sale](#) or other applicable terms available either on [ti.com](http://ti.com) or provided in conjunction with such TI products. TI's provision of these resources does not expand or otherwise alter TI's applicable warranties or warranty disclaimers for TI products.

TI objects to and rejects any additional or different terms you may have proposed.

Mailing Address: Texas Instruments, Post Office Box 655303, Dallas, Texas 75265  
Copyright © 2022, Texas Instruments Incorporated