

# DS3668

*DS3668 Quad Fault Protected Peripheral Driver*



Literature Number: SNLS351A

# DS3668

## Quad Fault Protected Peripheral Driver

### General Description

The DS3668 quad peripheral driver is designed for those applications where low operating power, high breakdown voltage, high output current and low output ON voltage are required. Unlike most peripheral drivers available, a unique fault protected circuit is incorporated on each output. When the load current exceeds 1.0A (approximately) on any output for more than a built-in delay time, nominally 12  $\mu$ s, that output will be shut off by its protection circuitry with no effect on other outputs. This condition will prevail until that protection circuitry is reset by toggling the corresponding input or the enable pin low for at least 1.0  $\mu$ s. This built-in delay is provided to ensure that the protection circuitry is not triggered by turn-on surge currents associated with certain kinds of loads.

The DS3668's inputs combine TTL compatibility with high input impedance. In fact, its extreme low input current allows it to be driven directly by a MOS device. The outputs are capable of sinking 600 mA each and offer a 70V breakdown. However, for inductive loads the output should be clamped to 35V or less to avoid latch up during turn off (inductive fly-back protection — refer AN-213). An on-chip clamp diode capable of handling 800 mA is provided at each output for this purpose. In addition, the DS3668 incorporates circuitry that guarantees glitch-free power up or down operation and a fail-safe feature which puts the output in a high impedance state when the input is open.

The molded package is specifically constructed to allow increased power dissipation over conventional packages. The four ground pins are directly connected to the device chip with a special copper lead frame. When the quad driver is soldered into a PC board, the power rating of the device improves significantly.

### Applications

- Relay drivers
- Solenoid drivers
- Hammer drivers
- Stepping motor drivers
- Triac drivers
- LED drivers
- High current, high voltage drivers
- Level translators
- Fiber optic LED drivers

### Features

- Output fault protection
- High impedance TTL compatible inputs
- High output current—600 mA per output
- No output latch-up at 35V
- Low output ON voltage (550 mV typ @ 600 mA)
- High breakdown voltage (70V)
- Open collector outputs
- Output clamp diodes for inductive fly-back protection
- NPN inputs for minimal input currents (1  $\mu$ A typical)
- Low operating power
- Standard 5V power supply
- Power up/down protection
- Fail-safe operation
- 2W power package
- Pin-for-pin compatible with SN75437

### Connection Diagram

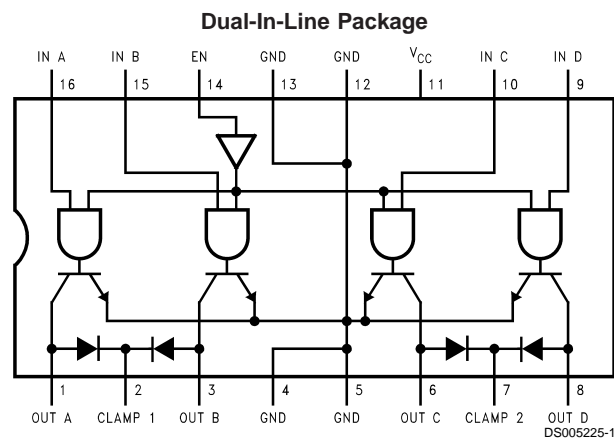

**Top View**  
**Order Number DS3668N**  
**See NS Package Number N16E**

## Truth Table

IN	EN	OUT
H	H	L
L	H	Z
H	L	Z
L	L	Z

H = High state

L = Low state

Z = High impedance state

**Absolute Maximum Ratings** (Note 1)

If Military/Aerospace specified devices are required, please contact the National Semiconductor Sales Office/Distributors for availability and specifications.

Supply Voltage	7.0V
Input Voltage	15V
Output Voltage	70V
Continuous Power Dissipation @ 25°C Free-Air (Note 5)	2075 mW

Storage Temperature Range -65°C to +150°C

Lead Temperature (Soldering, 4 seconds) 260

**Operating Conditions**

	Min	Max	Units
Supply Voltage	3.00	5.25	V
Ambient Temperature	-40	125	°C

**Electrical Characteristics** (Notes 2, 3, 6)

Symbol	Parameter	Conditions	Min	Typ	Max	Units
$V_{IH}$	Input High Voltage		2.0			V
$V_{IL}$	Input Low Voltage				0.8	V
$I_{IH}$	Input High Current	$V_{IN} = 5.25V, V_{CC} = 5.25V$		1.0	20	$\mu A$
$I_{IL}$	Input Low Current	$V_{IN} = 0.4V$			$\pm 10$	$\mu A$
$V_{IK}$	Input Clamp Voltage	$I_I = -12 \text{ mA}$		-0.8	-1.5	V
$V_{OL}$	Output Low Voltage	$I_L = 300 \text{ mA}$		0.2	0.7	V
		$I_L = 600 \text{ mA}$ (Note 4)		0.55	1.5	V
$I_{CEX}$	Output Leakage Current	$V_{CE} = 70V, V_{IN} = 0.8V$			100	$\mu A$
$V_F$	Diode Forward Voltage	$I_F = 800 \text{ mA}$		1.2	1.6	V
$I_R$	Diode Leakage Current	$V_R = 70V$			100	$\mu A$
$I_{CC}$	Supply Current	All Inputs High		62	80	mA
		All Inputs Low		20		mA
$I_{TH}$	Protection Circuit Threshold Current			1	1.4	A

**Switching Characteristics** (Notes 2, 6)

Symbol	Parameter	Conditions	Min	Typ	Max	Units
$t_{PHL}$	Turn On Delay	$R_L = 60\Omega, V_L = 30V$		0.3	1.0	$\mu s$
$t_{PLH}$	Turn Off Delay	$R_L = 60\Omega, V_L = 30V$		2	10.0	$\mu s$
$t_{FZ}$	Protection Enable Delay (after Detection of Fault)		6	12		$\mu s$
$t_{RL}$	Input Low Time for Protection Circuit Reset		1.0			$\mu s$

**Note 1:** "Absolute Maximum Ratings" are those values beyond which the safety of the device cannot be guaranteed. They are not meant to imply that the devices should be operated at these limits. The table of "Electrical Characteristics" specifies conditions of actual device operation.

**Note 2:** Unless otherwise specified, min/max limits apply across the 0°C to +70°C temperature range and the 4.75V to 5.25V power supply range. All typical values are for  $T_A = 25^\circ C$  and  $V_{CC} = 5.0V$ .

**Note 3:** All currents into device pins are shown as positive; all currents out of device pins are shown as negative; all voltages are referenced to ground, unless otherwise specified. All values shown as max or min are so classified on absolute value basis.

**Note 4:** All sectors of this quad circuit may conduct rated current simultaneously, however, power dissipation averaged over a short interval of time must fall within specified continuous dissipation ratings.

**Note 5:** For operation over 25°C free-air temperature, derate linearly to 1328 mW @ 70°C @ the rate of 16.6 mW/°C.

**Note 6:** Datasheet min/max specification limits are guaranteed by design, test, or statistical analysis.

### AC Test Circuit

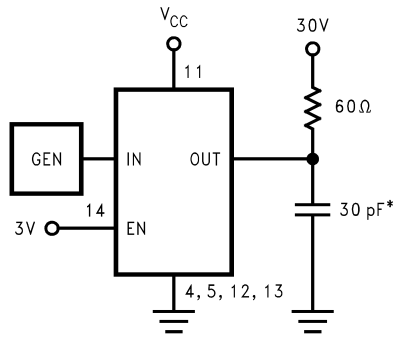

\*Includes probe and jig capacitance.

DS005225-2

### Switching Waveforms

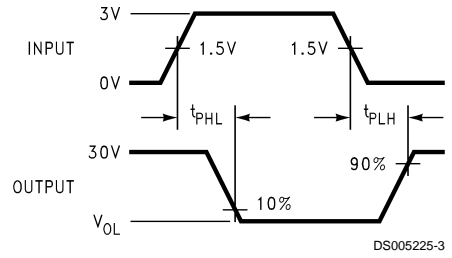

DS005225-3

### Typical Application

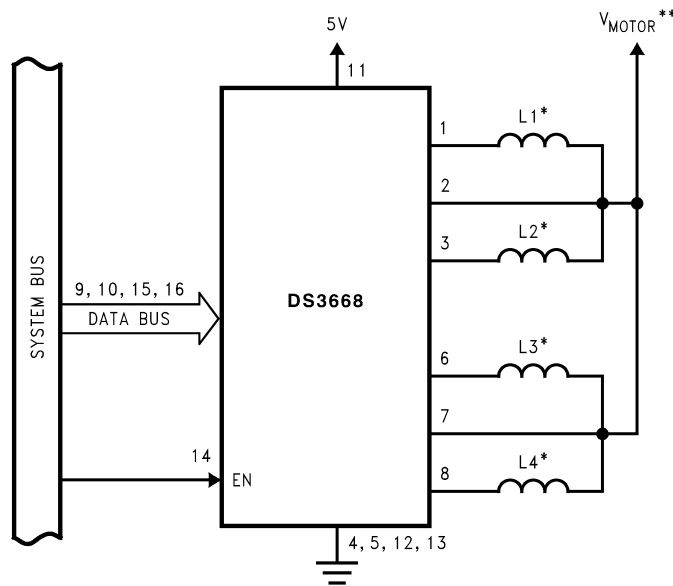

\*L1, L2, L3, L4 are the windings of a bifilar stepping motor.

\*\*VMOTOR is the supply voltage of the motor.

DS005225-4

### Protection Circuit Block Diagram

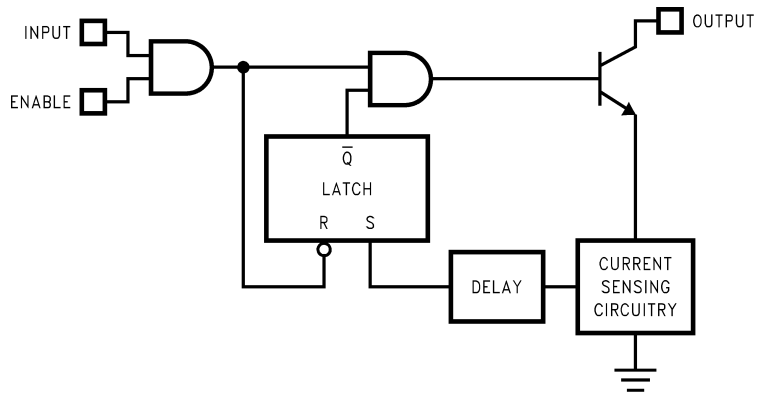

DS005225-5

**Physical Dimensions** inches (millimeters) unless otherwise noted

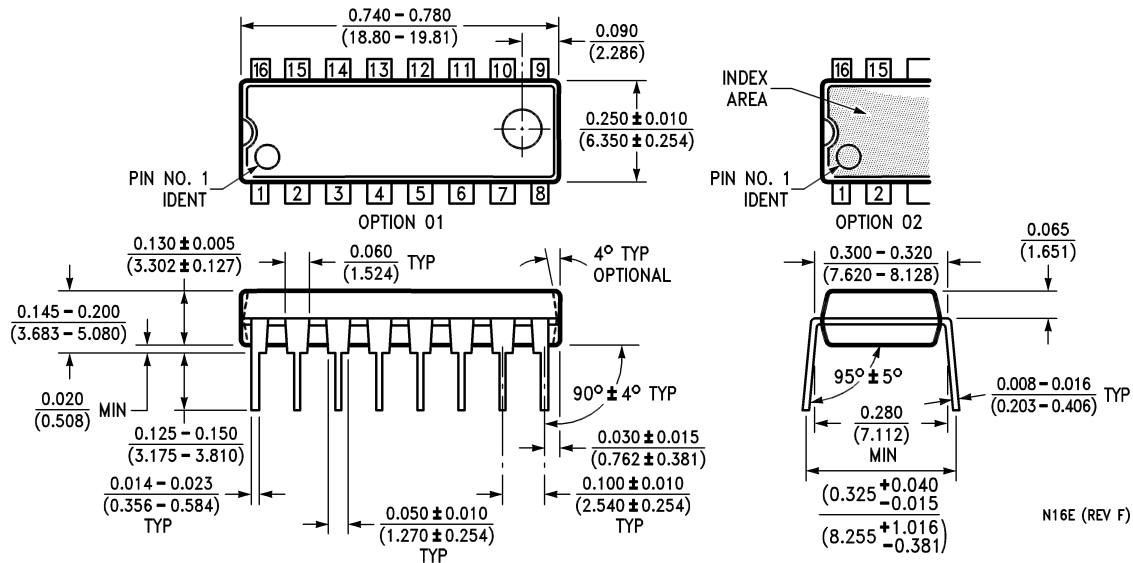

**Molded Dual-In-Line Package (N)**  
**Order Number DS3668N**  
**NS Package Number N16E**

N16E (REV F)

**LIFE SUPPORT POLICY**

NATIONAL'S PRODUCTS ARE NOT AUTHORIZED FOR USE AS CRITICAL COMPONENTS IN LIFE SUPPORT DEVICES OR SYSTEMS WITHOUT THE EXPRESS WRITTEN APPROVAL OF THE PRESIDENT AND GENERAL COUNSEL OF NATIONAL SEMICONDUCTOR CORPORATION. As used herein:

1. Life support devices or systems are devices or systems which, (a) are intended for surgical implant into the body, or (b) support or sustain life, and whose failure to perform when properly used in accordance with instructions for use provided in the labeling, can be reasonably expected to result in a significant injury to the user.
2. A critical component is any component of a life support device or system whose failure to perform can be reasonably expected to cause the failure of the life support device or system, or to affect its safety or effectiveness.



**National Semiconductor Corporation**  
 Americas  
 Tel: 1-800-272-9959  
 Fax: 1-800-737-7018  
 Email: support@nsc.com  
 www.national.com

**National Semiconductor Europe**  
 Fax: +49 (0) 180-530 85 86  
 Email: europe.support@nsc.com  
 Deutsch Tel: +49 (0) 69 9508 6208  
 English Tel: +44 (0) 870 24 0 2171  
 Français Tel: +33 (0) 1 41 91 8790

**National Semiconductor Asia Pacific Customer Response Group**  
 Tel: 65-2544466  
 Fax: 65-2504466  
 Email: ap.support@nsc.com

**National Semiconductor Japan Ltd.**  
 Tel: 81-3-5639-7560  
 Fax: 81-3-5639-7507

## IMPORTANT NOTICE

Texas Instruments Incorporated and its subsidiaries (TI) reserve the right to make corrections, modifications, enhancements, improvements, and other changes to its products and services at any time and to discontinue any product or service without notice. Customers should obtain the latest relevant information before placing orders and should verify that such information is current and complete. All products are sold subject to TI's terms and conditions of sale supplied at the time of order acknowledgment.

TI warrants performance of its hardware products to the specifications applicable at the time of sale in accordance with TI's standard warranty. Testing and other quality control techniques are used to the extent TI deems necessary to support this warranty. Except where mandated by government requirements, testing of all parameters of each product is not necessarily performed.

TI assumes no liability for applications assistance or customer product design. Customers are responsible for their products and applications using TI components. To minimize the risks associated with customer products and applications, customers should provide adequate design and operating safeguards.

TI does not warrant or represent that any license, either express or implied, is granted under any TI patent right, copyright, mask work right, or other TI intellectual property right relating to any combination, machine, or process in which TI products or services are used. Information published by TI regarding third-party products or services does not constitute a license from TI to use such products or services or a warranty or endorsement thereof. Use of such information may require a license from a third party under the patents or other intellectual property of the third party, or a license from TI under the patents or other intellectual property of TI.

Reproduction of TI information in TI data books or data sheets is permissible only if reproduction is without alteration and is accompanied by all associated warranties, conditions, limitations, and notices. Reproduction of this information with alteration is an unfair and deceptive business practice. TI is not responsible or liable for such altered documentation. Information of third parties may be subject to additional restrictions.

Resale of TI products or services with statements different from or beyond the parameters stated by TI for that product or service voids all express and any implied warranties for the associated TI product or service and is an unfair and deceptive business practice. TI is not responsible or liable for any such statements.

TI products are not authorized for use in safety-critical applications (such as life support) where a failure of the TI product would reasonably be expected to cause severe personal injury or death, unless officers of the parties have executed an agreement specifically governing such use. Buyers represent that they have all necessary expertise in the safety and regulatory ramifications of their applications, and acknowledge and agree that they are solely responsible for all legal, regulatory and safety-related requirements concerning their products and any use of TI products in such safety-critical applications, notwithstanding any applications-related information or support that may be provided by TI. Further, Buyers must fully indemnify TI and its representatives against any damages arising out of the use of TI products in such safety-critical applications.

TI products are neither designed nor intended for use in military/aerospace applications or environments unless the TI products are specifically designated by TI as military-grade or "enhanced plastic." Only products designated by TI as military-grade meet military specifications. Buyers acknowledge and agree that any such use of TI products which TI has not designated as military-grade is solely at the Buyer's risk, and that they are solely responsible for compliance with all legal and regulatory requirements in connection with such use.

TI products are neither designed nor intended for use in automotive applications or environments unless the specific TI products are designated by TI as compliant with ISO/TS 16949 requirements. Buyers acknowledge and agree that, if they use any non-designated products in automotive applications, TI will not be responsible for any failure to meet such requirements.

Following are URLs where you can obtain information on other Texas Instruments products and application solutions:

### Products

Audio	<a href="http://www.ti.com/audio">www.ti.com/audio</a>
Amplifiers	<a href="http://amplifier.ti.com">amplifier.ti.com</a>
Data Converters	<a href="http://dataconverter.ti.com">dataconverter.ti.com</a>
DLP® Products	<a href="http://www.dlp.com">www.dlp.com</a>
DSP	<a href="http://dsp.ti.com">dsp.ti.com</a>
Clocks and Timers	<a href="http://www.ti.com/clocks">www.ti.com/clocks</a>
Interface	<a href="http://interface.ti.com">interface.ti.com</a>
Logic	<a href="http://logic.ti.com">logic.ti.com</a>
Power Mgmt	<a href="http://power.ti.com">power.ti.com</a>
Microcontrollers	<a href="http://microcontroller.ti.com">microcontroller.ti.com</a>
RFID	<a href="http://www.ti-rfid.com">www.ti-rfid.com</a>
OMAP Mobile Processors	<a href="http://www.ti.com/omap">www.ti.com/omap</a>
Wireless Connectivity	<a href="http://www.ti.com/wirelessconnectivity">www.ti.com/wirelessconnectivity</a>

### Applications

Communications and Telecom	<a href="http://www.ti.com/communications">www.ti.com/communications</a>
Computers and Peripherals	<a href="http://www.ti.com/computers">www.ti.com/computers</a>
Consumer Electronics	<a href="http://www.ti.com/consumer-apps">www.ti.com/consumer-apps</a>
Energy and Lighting	<a href="http://www.ti.com/energy">www.ti.com/energy</a>
Industrial	<a href="http://www.ti.com/industrial">www.ti.com/industrial</a>
Medical	<a href="http://www.ti.com/medical">www.ti.com/medical</a>
Security	<a href="http://www.ti.com/security">www.ti.com/security</a>
Space, Avionics and Defense	<a href="http://www.ti.com/space-avionics-defense">www.ti.com/space-avionics-defense</a>
Transportation and Automotive	<a href="http://www.ti.com/automotive">www.ti.com/automotive</a>
Video and Imaging	<a href="http://www.ti.com/video">www.ti.com/video</a>

TI E2E Community Home Page

[e2e.ti.com](http://e2e.ti.com)

Mailing Address: Texas Instruments, Post Office Box 655303, Dallas, Texas 75265  
Copyright © 2011, Texas Instruments Incorporated