

## DLP9000 系列 0.9 WQXGA A 型 DMD

### 1 特性

- 高分辨率 2560×1600 (WQXGA) 阵列
  - 超过四百万个微镜
  - 7.56μm 微镜间距
  - 0.9 英寸微镜阵列对角线
  - ±12°微镜倾斜角（相对于平板状态）
  - 设计用于边缘照明
  - 集成微镜驱动器电路
  - 两个高速选项
- 采用 DLPC910 控制器的 DLP9000XFLS
  - 480Mhz 输入数据时钟速率
  - 对于持续输入数据流，最高像素数据速率大于 61 千兆位/秒
  - 1 位二进制模式速率达 15kHz
  - 采用调制照明的 8 位灰度模式，速率达 1.8kHz
- 采用两个 DLPC900 控制器的 DLP9000FLS
  - 400Mhz 输入数据时钟速率
  - 最高像素数据速率大于 38 千兆位/秒，多达 400 个预存储的二进制模式
  - 1 位二进制模式速率达 9.5kHz
  - 8 位灰度模式速率达 247Hz
- 设计用于宽波长范围
  - 400nm 至 700nm
  - 窗口传输效率 95%（单通、通过双窗面）
  - 微镜反射率 88%
  - 阵列衍射效率 86%
  - 阵列填充因子 92%

### 2 应用

- 工业
  - 机器视觉和质量控制
  - 3D 打印
  - 直接成像平版印刷术
  - 激光打标和修复
- 医疗
  - 眼科
  - 针对四肢和皮肤测量的 3D 扫描仪
  - 高光谱成像
  - 高光谱扫描
- 显示屏
  - 3D 成像显微镜
  - 智能和自适应照明

### 3 说明

高分辨率 DLP9000FLS 和 DLP9000XFLS 数字微镜器件 (DMD) 是可调制入射光幅度、方向和/或相位的空间照明调制器 (SLM)，微镜数超过四百万。这种高级照明控制技术适用于工业、医疗和消费品市场中的许多应用。DLP9000XFLS 自身具备的流传输性质与其 DLPC910 控制器相结合，可为平版印刷应用提供超高速持续数据流。这两款 DMD 能够为 3D 打印应用实现更大的构造尺寸和更为精细的分辨率。高分辨率支持扫描较大物体，这对于 3D 机器视觉应用有直接的帮助。

#### 器件信息(1)

器件型号	封装	封装尺寸（标称值）
DLP9000	CLGA (355)	42.20mm x 42.20mm x 7.00mm
DLP9000X		

(1) 要了解所有可用封装，请见数据表末尾的可订购产品附录。

DLP9000XFLS 的典型应用

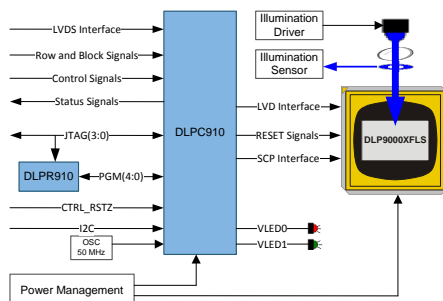

DLP9000FLS 的典型应用

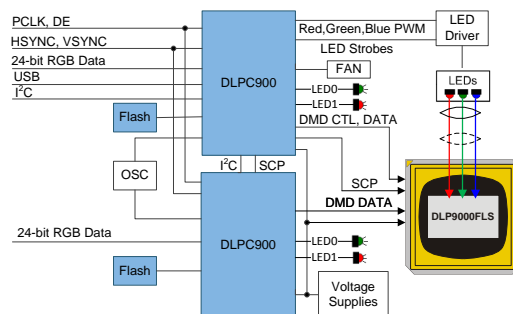

## 目录

<b>1</b>	<b>特性</b> .....	<b>1</b>	9.3	Feature Description .....	27
<b>2</b>	<b>应用</b> .....	<b>1</b>	9.4	Device Functional Modes .....	30
<b>3</b>	<b>说明</b> .....	<b>1</b>	9.5	Window Characteristics and Optics .....	30
<b>4</b>	<b>修订历史记录</b> .....	<b>2</b>	9.6	Micromirror Array Temperature Calculation .....	31
<b>5</b>	<b>Description (continued)</b> .....	<b>3</b>	9.7	Micromirror Landed-On/Landed-Off Duty Cycle .....	32
<b>6</b>	<b>Pin Configuration and Functions</b> .....	<b>3</b>	<b>10</b>	<b>Application and Implementation</b> .....	<b>35</b>
<b>7</b>	<b>Specifications</b> .....	<b>10</b>	10.1	Application Information .....	35
7.1	Absolute Maximum Ratings .....	10	10.2	Typical Applications .....	35
7.2	Storage Conditions .....	11	<b>11</b>	<b>Power Supply Recommendations</b> .....	<b>38</b>
7.3	ESD Ratings .....	11	11.1	DMD Power Supply Requirements .....	38
7.4	Recommended Operating Conditions .....	11	11.2	DMD Power Supply Power-Up Procedure .....	38
7.5	Thermal Information .....	13	11.3	DMD Power Supply Power-Down Procedure .....	38
7.6	Electrical Characteristics .....	13	<b>12</b>	<b>Layout</b> .....	<b>41</b>
7.7	Timing Requirements .....	14	12.1	Layout Guidelines .....	41
7.8	Capacitance at Recommended Operating Conditions .....	19	12.2	Layout Example .....	43
7.9	Typical Characteristics .....	19	<b>13</b>	<b>器件和文档支持</b> .....	<b>47</b>
7.10	System Mounting Interface Loads .....	20	13.1	器件支持 .....	47
7.11	Micromirror Array Physical Characteristics .....	20	13.2	文档支持 .....	48
7.12	Micromirror Array Optical Characteristics .....	22	13.3	社区资源 .....	48
7.13	Optical and System Image Quality .....	23	13.4	商标 .....	48
7.14	Window Characteristics .....	23	13.5	静电放电警告 .....	49
7.15	Chipset Component Usage Specification .....	23	13.6	Glossary .....	49
<b>8</b>	<b>Parameter Measurement Information</b> .....	<b>24</b>	<b>14</b>	<b>机械、封装和可订购信息</b> .....	<b>49</b>
<b>9</b>	<b>Detailed Description</b> .....	<b>25</b>	14.1	热特性 .....	49
9.1	Overview .....	25	14.2	封装热阻 .....	49
9.2	Functional Block Diagram .....	26	14.3	外壳温度 .....	49

## 4 修订历史记录

注：之前版本的页码可能与当前版本有所不同。

<b>Changes from Original (September 2014) to Revision A</b>	<b>Page</b>
• 已更新标题 .....	1
• 已更新特性, 说明和器件信息以包含 DLP9000XFLS DMD。 .....	1
• 已添加 DLP9000XFLS 应用图。 .....	1
• Updated <i>Absolute Maximum Ratings</i> to include DLP9000XFLS absolute maximum ratings. ....	10
• Updated <i>Recommended Operating Conditions</i> to include DLP9000XFLS recommended operating conditions.....	11
• Updated <i>Electrical Characteristics</i> to include DLP9000XFLS electrical characteristics.....	13
• Updated <i>Timing Requirements</i> to include DLP9000XFLS timing requirements.....	14
• Updated <i>Typical Characteristics</i> tables to have pixel data rates and pattern rates for both the DLP9000FLS and the DLP9000XFLS.....	19
• Updated <i>Device Functional Modes</i> section to include DLP9000XFLS functional description.....	30
• Updated <i>Application and Implementations</i> section to include typical application for the DLP9000XFLS. ....	35

## 5 Description (continued)

Reliable function and operation of the DLP9000 family requires that each DMD be used in conjunction with its specific digital controller. The DLP9000XFLS must be driven by a single DLPC910 Controller and the DLP9000FLS must be driven by two DLPC900 Controllers. These dedicated chipsets provide robust, high resolution, high speed system solutions.

## 6 Pin Configuration and Functions

**FLS Package Connector Terminals  
355-Pin CLGA  
Bottom View**

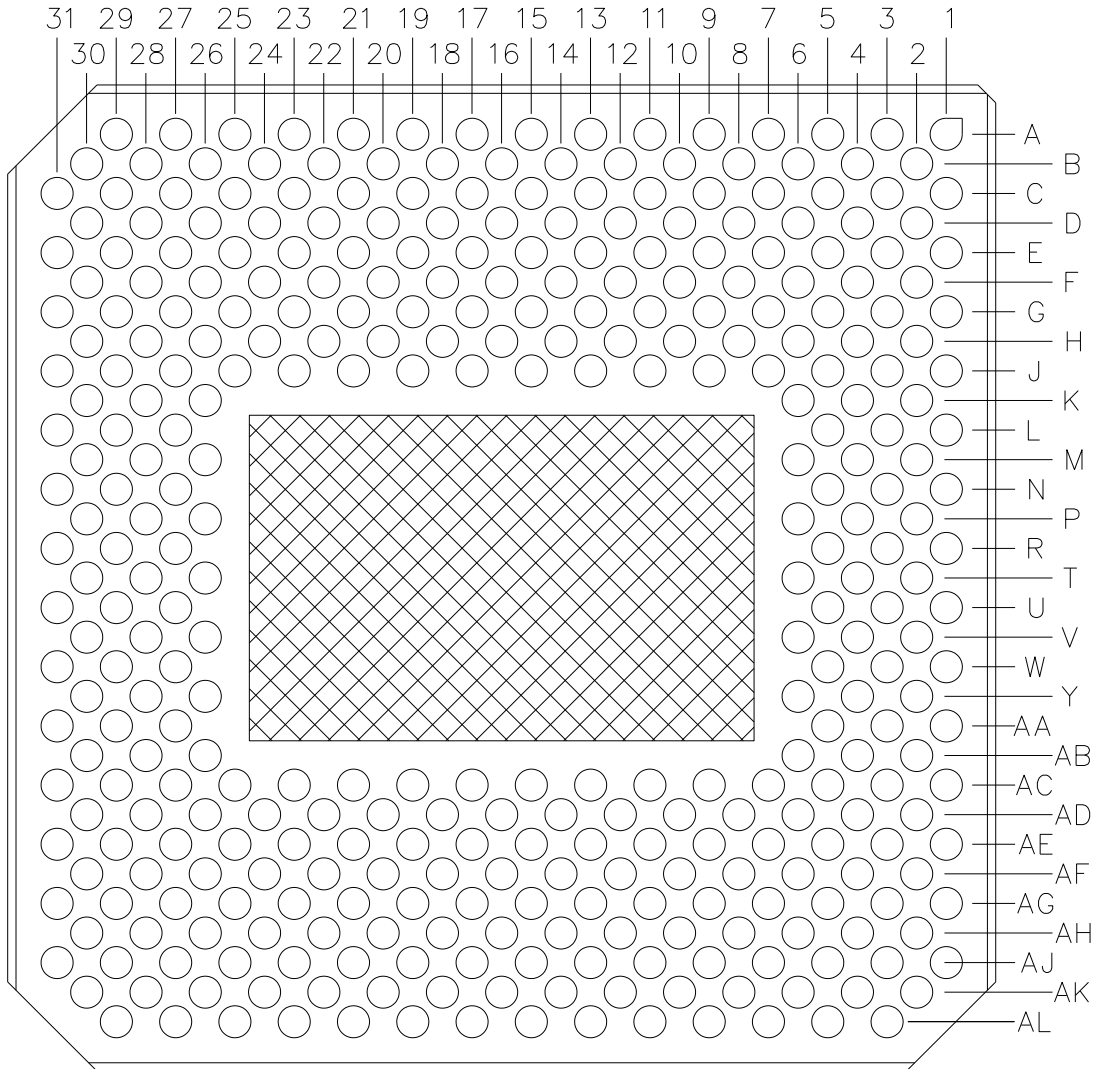

Pin Functions

PIN <sup>(1)</sup>		TYPE (I/O/P)	SIGNAL	DATA RATE <sup>(2)</sup>	INTERNAL TERM <sup>(3)</sup>	DESCRIPTION	TRACE (mils) <sup>(4)</sup>
NAME	NO.						
<b>DATA BUS A</b>							
D_AN(0)	H10	Input	LVDS	DDR	Differential	Data, Negative	737
D_AN(1)	G3	Input	LVDS	DDR	Differential	Data, Negative	737
D_AN(2)	G9	Input	LVDS	DDR	Differential	Data, Negative	737
D_AN(3)	F4	Input	LVDS	DDR	Differential	Data, Negative	738
D_AN(4)	F10	Input	LVDS	DDR	Differential	Data, Negative	739
D_AN(5)	E3	Input	LVDS	DDR	Differential	Data, Negative	739
D_AN(6)	E9	Input	LVDS	DDR	Differential	Data, Negative	737
D_AN(7)	D2	Input	LVDS	DDR	Differential	Data, Negative	737
D_AN(8)	J5	Input	LVDS	DDR	Differential	Data, Negative	739
D_AN(9)	C9	Input	LVDS	DDR	Differential	Data, Negative	736
D_AN(10)	F14	Input	LVDS	DDR	Differential	Data, Negative	743
D_AN(11)	B8	Input	LVDS	DDR	Differential	Data, Negative	737
D_AN(12)	G15	Input	LVDS	DDR	Differential	Data, Negative	739
D_AN(13)	B14	Input	LVDS	DDR	Differential	Data, Negative	740
D_AN(14)	H16	Input	LVDS	DDR	Differential	Data, Negative	737
D_AN(15)	D16	Input	LVDS	DDR	Differential	Data, Negative	737
D_AP(0)	H8	Input	LVDS	DDR	Differential	Data, Positive	737
D_AP(1)	G5	Input	LVDS	DDR	Differential	Data, Positive	738
D_AP(2)	G11	Input	LVDS	DDR	Differential	Data, Positive	737
D_AP(3)	F2	Input	LVDS	DDR	Differential	Data, Positive	736
D_AP(4)	F8	Input	LVDS	DDR	Differential	Data, Positive	739
D_AP(5)	E5	Input	LVDS	DDR	Differential	Data, Positive	738
D_AP(6)	E11	Input	LVDS	DDR	Differential	Data, Positive	737
D_AP(7)	D4	Input	LVDS	DDR	Differential	Data, Positive	737
D_AP(8)	J3	Input	LVDS	DDR	Differential	Data, Positive	739
D_AP(9)	C11	Input	LVDS	DDR	Differential	Data, Positive	737
D_AP(10)	F16	Input	LVDS	DDR	Differential	Data, Positive	741
D_AP(11)	B10	Input	LVDS	DDR	Differential	Data, Positive	737
D_AP(12)	H14	Input	LVDS	DDR	Differential	Data, Positive	739
D_AP(13)	B16	Input	LVDS	DDR	Differential	Data, Positive	739
D_AP(14)	G17	Input	LVDS	DDR	Differential	Data, Positive	737
D_AP(15)	D14	Input	LVDS	DDR	Differential	Data, Positive	737
<b>DATA BUS B</b>							
D_BN(0)	AD8	Input	LVDS	DDR	Differential	Data, Negative	739
D_BN(1)	AE3	Input	LVDS	DDR	Differential	Data, Negative	737
D_BN(2)	AF8	Input	LVDS	DDR	Differential	Data, Negative	736
D_BN(3)	AF2	Input	LVDS	DDR	Differential	Data, Negative	739
D_BN(4)	AG5	Input	LVDS	DDR	Differential	Data, Negative	737
D_BN(5)	AH8	Input	LVDS	DDR	Differential	Data, Negative	737
D_BN(6)	AG9	Input	LVDS	DDR	Differential	Data, Negative	737
D_BN(7)	AH2	Input	LVDS	DDR	Differential	Data, Negative	739

- (1) The following power supplies are required to operate the DMD: VCC, VCCI, VOFFSET, VBIAS, and VRESET. VSS must also be connected.
- (2) DDR = Double Data Rate.  
SDR = Single Data Rate.  
Refer to the [Timing Requirements](#) regarding specifications and relationships.
- (3) Internal term = CMOS level internal termination. Refer to [Recommended Operating Conditions](#) regarding differential termination specification.
- (4) Dielectric Constant for the DMD Type A ceramic package is approximately 9.6.  
For the package trace lengths shown:  
Propagation Speed =  $11.8 / \sqrt{9.6} = 3.808$  in/ns.  
Propagation Delay =  $0.262$  ns/in =  $262$  ps/in =  $10.315$  ps/mm.

**Pin Functions (continued)**

PIN <sup>(1)</sup>		TYPE (I/O/P)	SIGNAL	DATA RATE <sup>(2)</sup>	INTERNAL TERM <sup>(3)</sup>	DESCRIPTION	TRACE (mils) <sup>(4)</sup>
NAME	NO.						
D_BN(8)	AL9	Input	LVDS	DDR	Differential	Data, Negative	737
D_BN(9)	AJ11	Input	LVDS	DDR	Differential	Data, Negative	738
D_BN(10)	AF14	Input	LVDS	DDR	Differential	Data, Negative	736
D_BN(11)	AE11	Input	LVDS	DDR	Differential	Data, Negative	737
D_BN(12)	AH16	Input	LVDS	DDR	Differential	Data, Negative	740
D_BN(13)	AD14	Input	LVDS	DDR	Differential	Data, Negative	737
D_BN(14)	AG17	Input	LVDS	DDR	Differential	Data, Negative	738
D_BN(15)	AD16	Input	LVDS	DDR	Differential	Data, Negative	738
D_BP(0)	AD10	Input	LVDS	DDR	Differential	Data, Positive	738
D_BP(1)	AE5	Input	LVDS	DDR	Differential	Data, Positive	737
D_BP(2)	AF10	Input	LVDS	DDR	Differential	Data, Positive	737
D_BP(3)	AF4	Input	LVDS	DDR	Differential	Data, Positive	738
D_BP(4)	AG3	Input	LVDS	DDR	Differential	Data, Positive	737
D_BP(5)	AH10	Input	LVDS	DDR	Differential	Data, Positive	737
D_BP(6)	AG11	Input	LVDS	DDR	Differential	Data, Positive	737
D_BP(7)	AH4	Input	LVDS	DDR	Differential	Data, Positive	740
D_BP(8)	AL11	Input	LVDS	DDR	Differential	Data, Positive	736
D_BP(9)	AJ9	Input	LVDS	DDR	Differential	Data, Positive	739
D_BP(10)	AF16	Input	LVDS	DDR	Differential	Data, Positive	737
D_BP(11)	AE9	Input	LVDS	DDR	Differential	Data, Positive	737
D_BP(12)	AH14	Input	LVDS	DDR	Differential	Data, Positive	737
D_BP(13)	AE15	Input	LVDS	DDR	Differential	Data, Positive	737
D_BP(14)	AG15	Input	LVDS	DDR	Differential	Data, Positive	740
D_BP(15)	AE17	Input	LVDS	DDR	Differential	Data, Positive	739
<b>DATA BUS C</b>							
D_CN(0)	C15	Input	LVDS	DDR	Differential	Data, Negative	737
D_CN(1)	E15	Input	LVDS	DDR	Differential	Data, Negative	737
D_CN(2)	A17	Input	LVDS	DDR	Differential	Data, Negative	736
D_CN(3)	F20	Input	LVDS	DDR	Differential	Data, Negative	737
D_CN(4)	B20	Input	LVDS	DDR	Differential	Data, Negative	738
D_CN(5)	G21	Input	LVDS	DDR	Differential	Data, Negative	737
D_CN(6)	D22	Input	LVDS	DDR	Differential	Data, Negative	737
D_CN(7)	E23	Input	LVDS	DDR	Differential	Data, Negative	737
D_CN(8)	B26	Input	LVDS	DDR	Differential	Data, Negative	739
D_CN(9)	F28	Input	LVDS	DDR	Differential	Data, Negative	737
D_CN(10)	C27	Input	LVDS	DDR	Differential	Data, Negative	737
D_CN(11)	J29	Input	LVDS	DDR	Differential	Data, Negative	737
D_CN(12)	D26	Input	LVDS	DDR	Differential	Data, Negative	737
D_CN(13)	H26	Input	LVDS	DDR	Differential	Data, Negative	739
D_CN(14)	E29	Input	LVDS	DDR	Differential	Data, Negative	736
D_CN(15)	G29	Input	LVDS	DDR	Differential	Data, Negative	737
D_CP(0)	C17	Input	LVDS	DDR	Differential	Data, Positive	738
D_CP(1)	E17	Input	LVDS	DDR	Differential	Data, Positive	737
D_CP(2)	A15	Input	LVDS	DDR	Differential	Data, Positive	735
D_CP(3)	F22	Input	LVDS	DDR	Differential	Data, Positive	737
D_CP(4)	B22	Input	LVDS	DDR	Differential	Data, Positive	737
D_CP(5)	H20	Input	LVDS	DDR	Differential	Data, Positive	737
D_CP(6)	D20	Input	LVDS	DDR	Differential	Data, Positive	737
D_CP(7)	E21	Input	LVDS	DDR	Differential	Data, Positive	737
D_CP(8)	B28	Input	LVDS	DDR	Differential	Data, Positive	739

**Pin Functions (continued)**

PIN <sup>(1)</sup>		TYPE (I/O/P)	SIGNAL	DATA RATE <sup>(2)</sup>	INTERNAL TERM <sup>(3)</sup>	DESCRIPTION	TRACE (mils) <sup>(4)</sup>
NAME	NO.						
D_CP(9)	F26	Input	LVDS	DDR	Differential	Data, Positive	735
D_CP(10)	C29	Input	LVDS	DDR	Differential	Data, Positive	737
D_CP(11)	J27	Input	LVDS	DDR	Differential	Data, Positive	737
D_CP(12)	D28	Input	LVDS	DDR	Differential	Data, Positive	736
D_CP(13)	H28	Input	LVDS	DDR	Differential	Data, Positive	739
D_CP(14)	E27	Input	LVDS	DDR	Differential	Data, Positive	736
D_CP(15)	G27	Input	LVDS	DDR	Differential	Data, Positive	737
<b>DATA BUS D</b>							
D_DN(0)	AJ15	Input	LVDS	DDR	Differential	Data, Negative	737
D_DN(1)	AC27	Input	LVDS	DDR	Differential	Data, Negative	737
D_DN(2)	AK16	Input	LVDS	DDR	Differential	Data, Negative	738
D_DN(3)	AE29	Input	LVDS	DDR	Differential	Data, Negative	738
D_DN(4)	AE21	Input	LVDS	DDR	Differential	Data, Negative	737
D_DN(5)	AF20	Input	LVDS	DDR	Differential	Data, Negative	738
D_DN(6)	AL15	Input	LVDS	DDR	Differential	Data, Negative	737
D_DN(7)	AG29	Input	LVDS	DDR	Differential	Data, Negative	738
D_DN(8)	AD22	Input	LVDS	DDR	Differential	Data, Negative	739
D_DN(9)	AG21	Input	LVDS	DDR	Differential	Data, Negative	738
D_DN(10)	AJ23	Input	LVDS	DDR	Differential	Data, Negative	736
D_DN(11)	AJ29	Input	LVDS	DDR	Differential	Data, Negative	737
D_DN(12)	AF28	Input	LVDS	DDR	Differential	Data, Negative	737
D_DN(13)	AK22	Input	LVDS	DDR	Differential	Data, Negative	741
D_DN(14)	AD28	Input	LVDS	DDR	Differential	Data, Negative	739
D_DN(15)	AK28	Input	LVDS	DDR	Differential	Data, Negative	739
D_DP(0)	AJ17	Input	LVDS	DDR	Differential	Data, Positive	737
D_DP(1)	AC29	Input	LVDS	DDR	Differential	Data, Positive	737
D_DP(2)	AK14	Input	LVDS	DDR	Differential	Data, Positive	738
D_DP(3)	AE27	Input	LVDS	DDR	Differential	Data, Positive	737
D_DP(4)	AD20	Input	LVDS	DDR	Differential	Data, Positive	737
D_DP(5)	AF22	Input	LVDS	DDR	Differential	Data, Positive	738
D_DP(6)	AL17	Input	LVDS	DDR	Differential	Data, Positive	737
D_DP(7)	AG27	Input	LVDS	DDR	Differential	Data, Positive	738
D_DP(8)	AE23	Input	LVDS	DDR	Differential	Data, Positive	739
D_DP(9)	AG23	Input	LVDS	DDR	Differential	Data, Positive	738
D_DP(10)	AJ21	Input	LVDS	DDR	Differential	Data, Positive	736
D_DP(11)	AJ27	Input	LVDS	DDR	Differential	Data, Positive	737
D_DP(12)	AF26	Input	LVDS	DDR	Differential	Data, Positive	737
D_DP(13)	AK20	Input	LVDS	DDR	Differential	Data, Positive	740
D_DP(14)	AD26	Input	LVDS	DDR	Differential	Data, Positive	739
D_DP(15)	AK26	Input	LVDS	DDR	Differential	Data, Positive	739
<b>SERIAL CONTROL</b>							
SCTRL_AN	D8	Input	LVDS	DDR	Differential	Serial Control, Negative	736
SCTRL_BN	AK8	Input	LVDS	DDR	Differential	Serial Control, Negative	739
SCTRL_CN	G23	Input	LVDS	DDR	Differential	Serial Control, Negative	737
SCTRL_DN	AH28	Input	LVDS	DDR	Differential	Serial Control, Negative	739
SCTRL_AP	D10	Input	LVDS	DDR	Differential	Serial Control, Positive	736
SCTRL_BP	AK10	Input	LVDS	DDR	Differential	Serial Control, Positive	739
SCTRL_CP	H22	Input	LVDS	DDR	Differential	Serial Control, Positive	739
SCTRL_DP	AH26	Input	LVDS	DDR	Differential	Serial Control, Positive	739

**Pin Functions (continued)**

PIN <sup>(1)</sup>		TYPE (I/O/P)	SIGNAL	DATA RATE <sup>(2)</sup>	INTERNAL TERM <sup>(3)</sup>	DESCRIPTION	TRACE (mils) <sup>(4)</sup>
NAME	NO.						
<b>CLOCKS</b>							
DCLK_AN	H2	Input	LVDS		Differential	Clock, Negative	740
DCLK_BN	AJ5	Input	LVDS		Differential	Clock, Negative	740
DCLK_CN	C23	Input	LVDS		Differential	Clock, Negative	736
DCLK_DN	AH22	Input	LVDS		Differential	Clock, Negative	736
DCLK_AP	H4	Input	LVDS		Differential	Clock, Positive	740
DCLK_BP	AJ3	Input	LVDS		Differential	Clock, Positive	740
DCLK_CP	C21	Input	LVDS		Differential	Clock, Positive	736
DCLK_DP	AH20	Input	LVDS		Differential	Clock, Positive	738
<b>SERIAL COMMUNICATIONS PORT (SCP)</b>							
SCP_DO	AC3	Output	LVC MOS	SDR		Serial Communications Port Output	
SCP_DI	AD2	Input	LVC MOS	SDR	Pull-Down	Serial Communications Port Data Input	
SCP_CLK	AE1	Input	LVC MOS		Pull-Down	Serial Communications Port Clock	
SCP_ENZ	AD4	Input	LVC MOS		Pull-Down	Active-low Serial Communications Port Enable	
<b>MICROMIRROR RESET CONTROL</b>							
RESET_ADDR(0)	H12	Input	LVC MOS		Pull-Down	Reset Driver Address Select	
RESET_ADDR(1)	C5	Input	LVC MOS		Pull-Down	Reset Driver Address Select	
RESET_ADDR(2)	B6	Input	LVC MOS		Pull-Down	Reset Driver Address Select	
RESET_ADDR(3)	A19	Input	LVC MOS		Pull-Down	Reset Driver Address Select	
RESET_MODE(0)	J1	Input	LVC MOS		Pull-Down	Reset Driver Mode Select	
RESET_MODE(1)	G1	Input	LVC MOS		Pull-Down	Reset Driver Mode Select	
RESET_SEL(0)	AK4	Input	LVC MOS		Pull-Down	Reset Driver Level Select	
RESET_SEL(1)	AL13	Input	LVC MOS		Pull-Down	Reset Driver Level Select	
RESET_STROBE	H6	Input	LVC MOS		Pull-Down	Reset Address, Mode, & Level latched on rising-edge	
<b>ENABLES AND INTERRUPTS</b>							
PWRDNZ	B4	Input	LVC MOS			Active-low Device Reset	
RESET_OEZ	AK24	Input	LVC MOS		Pull-Down	Active-low output enable for DMD reset driver circuits	
RESETZ	AL19	Input	LVC MOS		Pull-Down	Active-low sets Reset circuits in known VOFFSET state	
RESET_IRQZ	C3	Output	LVC MOS			Active-low, output interrupt to ASIC	
<b>VOLTAGE REGULATOR MONITORING</b>							
PG_BIAS	J19	Input	LVC MOS		Pull-Up	Active-low fault from external VBIAS regulator	
PG_OFFSET	A13	Input	LVC MOS		Pull-Up	Active-low fault from external VOFFSET regulator	
PG_RESET	AC19	Input	LVC MOS		Pull-Up	Active-low fault from external VRESET regulator	
EN_BIAS	J15	Output	LVC MOS			Active-high enable for external VBIAS regulator	
EN_OFFSET	H30	Output	LVC MOS			Active-high enable for external VOFFSET regulator	
EN_RESET	J17	Output	LVC MOS			Active-high enable for external VRESET regulator	
<b>LEAVE PIN UNCONNECTED</b>							
MBRST(0)	L5	Output	Analog		Pull-Down	For proper DMD operation, do not connect	
MBRST(1)	M28	Output	Analog		Pull-Down	For proper DMD operation, do not connect	
MBRST(2)	P4	Output	Analog		Pull-Down	For proper DMD operation, do not connect	
MBRST(3)	P30	Output	Analog		Pull-Down	For proper DMD operation, do not connect	
MBRST(4)	L3	Output	Analog		Pull-Down	For proper DMD operation, do not connect	
MBRST(5)	P28	Output	Analog		Pull-Down	For proper DMD operation, do not connect	
MBRST(6)	P2	Output	Analog		Pull-Down	For proper DMD operation, do not connect	

**Pin Functions (continued)**

PIN <sup>(1)</sup>		TYPE (I/O/P)	SIGNAL	DATA RATE <sup>(2)</sup>	INTERNAL TERM <sup>(3)</sup>	DESCRIPTION	TRACE (mils) <sup>(4)</sup>
NAME	NO.						
MBRST(7)	T28	Output	Analog		Pull-Down	For proper DMD operation, do not connect	
MBRST(8)	M4	Output	Analog		Pull-Down	For proper DMD operation, do not connect	
MBRST(9)	L29	Output	Analog		Pull-Down	For proper DMD operation, do not connect	
MBRST(10)	T4	Output	Analog		Pull-Down	For proper DMD operation, do not connect	
MBRST(11)	N29	Output	Analog		Pull-Down	For proper DMD operation, do not connect	
MBRST(12)	N3	Output	Analog		Pull-Down	For proper DMD operation, do not connect	
MBRST(13)	L27	Output	Analog		Pull-Down	For proper DMD operation, do not connect	
MBRST(14)	R3	Output	Analog		Pull-Down	For proper DMD operation, do not connect	
MBRST(15)	V28	Output	Analog		Pull-Down	For proper DMD operation, do not connect	
MBRST(16)	V4	Output	Analog		Pull-Down	For proper DMD operation, do not connect	
MBRST(17)	R29	Output	Analog		Pull-Down	For proper DMD operation, do not connect	
MBRST(18)	Y4	Output	Analog		Pull-Down	For proper DMD operation, do not connect	
MBRST(19)	AA27	Output	Analog		Pull-Down	For proper DMD operation, do not connect	
MBRST(20)	W3	Output	Analog		Pull-Down	For proper DMD operation, do not connect	
MBRST(21)	W27	Output	Analog		Pull-Down	For proper DMD operation, do not connect	
MBRST(22)	AA3	Output	Analog		Pull-Down	For proper DMD operation, do not connect	
MBRST(23)	W29	Output	Analog		Pull-Down	For proper DMD operation, do not connect	
MBRST(24)	U5	Output	Analog		Pull-Down	For proper DMD operation, do not connect	
MBRST(25)	U29	Output	Analog		Pull-Down	For proper DMD operation, do not connect	
MBRST(26)	Y2	Output	Analog		Pull-Down	For proper DMD operation, do not connect	
MBRST(27)	AA29	Output	Analog		Pull-Down	For proper DMD operation, do not connect	
MBRST(28)	U3	Output	Analog		Pull-Down	For proper DMD operation, do not connect	
MBRST(29)	Y30	Output	Analog		Pull-Down	For proper DMD operation, do not connect	
MBRST(30)	AA5	Output	Analog		Pull-Down	For proper DMD operation, do not connect	
MBRST(31)	R27	Output	Analog		Pull-Down	For proper DMD operation, do not connect	
<b>LEAVE PIN UNCONNECTED</b>							
RESERVED_PFE	J11	Input	LVC MOS		Pull-Down	For proper DMD operation, do not connect	
RESERVED_TM	AC7	Input	LVC MOS		Pull-Down	For proper DMD operation, do not connect	
RESERVED_XI0	AC25	Input	LVC MOS		Pull-Down	For proper DMD operation, do not connect	
RESERVED_XI1	AC23	Input	LVC MOS		Pull-Down	For proper DMD operation, do not connect	
RESERVED_XI2	J23	Input	LVC MOS		Pull-Down	For proper DMD operation, do not connect	
RESERVED_TP0	AC9	Input	Analog			For proper DMD operation, do not connect	
RESERVED_TP1	AC11	Input	Analog			For proper DMD operation, do not connect	
RESERVED_TP2	AC13	Input	Analog			For proper DMD operation, do not connect	
<b>LEAVE PIN UNCONNECTED</b>							
RESERVED_BA	AC15	Output	LVC MOS			For proper DMD operation, do not connect	
RESERVED_BB	J13	Output	LVC MOS			For proper DMD operation, do not connect	
RESERVED_BC	AC21	Output	LVC MOS			For proper DMD operation, do not connect	
RESERVED_BD	J21	Output	LVC MOS			For proper DMD operation, do not connect	
RESERVED_TS	AC17	Output	LVC MOS			For proper DMD operation, do not connect	
<b>LEAVE PIN UNCONNECTED</b>							
NO CONNECT	J7					For proper DMD operation, do not connect	
NO CONNECT	J9					For proper DMD operation, do not connect	
NO CONNECT	J25					For proper DMD operation, do not connect	

### Pin Functions

NAME <sup>(1)</sup>	PIN			TYPE (I/O/P)	SIGNAL	DESCRIPTION
	NO.	NO.	NO.			
VBIAS	A3	A5	A7	Power	Analog	Supply voltage for positive Bias level of Micromirror reset signal.
VBIAS	A9	A11	B2	Power	Analog	Supply voltage for positive Bias level of Micromirror reset signal.
VOFFSET	L1	N1	R1	Power	Analog	Supply voltage for HVCMOS logic.
VOFFSET	U1	W1		Power	Analog	Supply voltage for stepped high voltage at Micromirror address electrodes.
VOFFSET	AC1		AA1	Power	Analog	Supply voltage for Offset level of MBRST(31:0).
VRESET	L31	N31	R31	Power	Analog	Supply voltage for negative Reset level of Micromirror reset signal.
VRESET	U31	W31	AA31	Power	Analog	Supply voltage for negative Reset level of Micromirror reset signal.
VCC	A21	A23	A25	Power	Analog	Supply voltage for LVCMOS core logic. Supply voltage for normal high level at Micromirror address electrodes.
VCC	A27	A29	C1	Power	Analog	
VCC	C31	E31	G31	Power	Analog	
VCC	J31	K2	AC31	Power	Analog	
VCC	AE31	AG1	AG31	Power	Analog	
VCC	AJ31	AK2	AK30	Power	Analog	
VCC	AL3	AL5	AL7	Power	Analog	
VCC	AL21	AL23	AL25	Power	Analog	
VCC	AL27			Power	Analog	
VCCI	H18	H24	M6	Power	Analog	Supply voltage for LVDS receivers.
VCCI	M26	P6	P26	Power	Analog	Supply voltage for LVDS receivers.
VCCI	T6	T26	V6	Power	Analog	Supply voltage for LVDS receivers.
VCCI	V26	Y6	Y26	Power	Analog	Supply voltage for LVDS receivers.
VCCI	AD6	AD12	AD18	Power	Analog	Supply voltage for LVDS receivers.
VCCI	AD24			Power	Analog	Supply voltage for LVDS receivers.
VSS	A1	B12	B18	Power	Analog	Device Ground. Common return for all power.
VSS	B24	B30	C7	Power	Analog	Device Ground. Common return for all power.
VSS	C13	C19	C25	Power	Analog	Device Ground. Common return for all power.
VSS	D6	D12	D18	Power	Analog	Device Ground. Common return for all power.
VSS	D24	D30	E1	Power	Analog	Device Ground. Common return for all power.
VSS	E7	E13	E19	Power	Analog	Device Ground. Common return for all power.
VSS	E25	F6	F12	Power	Analog	Device Ground. Common return for all power.
VSS	F18	F24	F30	Power	Analog	Device Ground. Common return for all power.
VSS	G7	G13	G19	Power	Analog	Device Ground. Common return for all power.
VSS	G25	K4	K6	Power	Analog	Device Ground. Common return for all power.
VSS	K26	K28	K30	Power	Analog	Device Ground. Common return for all power.
VSS	M2	M30	N5	Power	Analog	Device Ground. Common return for all power.
VSS	N27	R5	T2	Power	Analog	Device Ground. Common return for all power.
VSS	T30	U27	V2	Power	Analog	Device Ground. Common return for all power.
VSS	V30	W5	Y28	Power	Analog	Device Ground. Common return for all power.
VSS	AB2	AB4	AB6	Power	Analog	Device Ground. Common return for all power.
VSS	AB26	AB28	AB30	Power	Analog	Device Ground. Common return for all power.
VSS	AC5	AD30	AE7	Power	Analog	Device Ground. Common return for all power.
VSS	AE13	AE19	AE25	Power	Analog	Device Ground. Common return for all power.
VSS	AF6	AF12	AF18	Power	Analog	Device Ground. Common return for all power.
VSS	AF24	AF30	AG7	Power	Analog	Device Ground. Common return for all power.
VSS	AG13	AG19	AG25	Power	Analog	Device Ground. Common return for all power.
VSS	AH6	AH12	AH18	Power	Analog	Device Ground. Common return for all power.
VSS	AH24	AH30	AJ1	Power	Analog	Device Ground. Common return for all power.
VSS	AJ7	AJ13	AJ19	Power	Analog	Device Ground. Common return for all power.

(1) The following power supplies are required to operate the DMD: VCC, VCCI, VOFFSET, VBIAS, and VRESET. VSS must also be connected.

**Pin Functions (continued)**

PIN				TYPE (I/O/P)	SIGNAL	DESCRIPTION
NAME <sup>(1)</sup>	NO.	NO.	NO.			
VSS	AJ25	AK6	AK12	Power	Analog	Device Ground. Common return for all power.
VSS	AK18	AL29		Power	Analog	Device Ground. Common return for all power.

**7 Specifications**

**7.1 Absolute Maximum Ratings**

over operating free-air temperature range (unless otherwise noted) <sup>(1)</sup>

		MIN	MAX	UNIT
<b>SUPPLY VOLTAGES</b>				
VCC	Supply voltage for LVCMOS core logic <sup>(2)</sup>	-0.5	4	V
VCCI	Supply voltage for LVDS receivers <sup>(2)</sup>	-0.5	4	V
VOFFSET	Supply voltage for HVCMOS and micromirror electrode <sup>(2) (3)</sup>	-0.5	9	V
VBIAS	Supply voltage for micromirror electrode <sup>(2)</sup>	-0.5	17	V
VRESET	Supply voltage for micromirror electrode <sup>(2)</sup>	-11	0.5	V
VCC – VCCI	Supply voltage delta (absolute value) <sup>(4)</sup>		0.3	V
VBIAS – VOFFSET	Supply voltage delta (absolute value) <sup>(5)</sup>		8.75	V
<b>INPUT VOLTAGES</b>				
	Input voltage for all other LVCMOS input pins <sup>(2)</sup>	-0.5	VCC + 0.3	V
	Input voltage for all other LVDS input pins <sup>(2) (6)</sup>	-0.5	VCCI + 0.3	V
V <sub>ID</sub>	Input differential voltage (absolute value) <sup>(7)</sup>		700	mV
I <sub>ID</sub>	Input differential current <sup>(7)</sup>		7	mA
<b>CLOCKS</b>				
f <sub>clock</sub>	DLP9000FLS	Clock frequency for LVDS interface, DCLK_A	460	MHz
		Clock frequency for LVDS interface, DCLK_B	460	MHz
		Clock frequency for LVDS interface, DCLK_C	460	MHz
		Clock frequency for LVDS interface, DCLK_D	460	MHz
	DLP9000XFLS	Clock frequency for LVDS interface, DCLK_A	500	MHz
		Clock frequency for LVDS interface, DCLK_B	500	MHz
		Clock frequency for LVDS interface, DCLK_C	500	MHz
		Clock frequency for LVDS interface, DCLK_D	500	MHz
<b>ENVIRONMENTAL</b>				
T <sub>CASE</sub>	Case temperature: operational <sup>(8) (9)</sup>	0	70	°C
	Case temperature: non-operational <sup>(9)</sup>	-40	80	°C
T <sub>GRADIENT</sub>	Differential temperature <sup>(8)</sup>		10	°C
	Operating relative humidity (non-condensing)	0	95%	RH

- (1) Stresses beyond those listed under *Absolute Maximum Ratings* may cause permanent damage to the device. These are stress ratings only, and functional operation of the device is not implied at these or any other conditions beyond those indicated under *Recommended Operating Conditions*. Exposure above *Recommended Operating Conditions* for extended periods may affect device reliability.
- (2) All voltages are referenced to common ground VSS. Supply voltages VCC, VCCI, VOFFSET, VBIAS, and VRESET are all required for proper DMD operation. VSS must also be connected
- (3) VOFFSET supply transients must fall within specified voltages.
- (4) To prevent excess current, the supply voltage delta |VCCI – VCC| must be less than specified limit.
- (5) To prevent excess current, the supply voltage delta |VBIAS – VOFFSET| must be less than specified limit. Refer to *Power Supply Recommendations* for additional information.
- (6) This maximum LVDS input voltage rating applies when each input of a differential pair is at the same voltage potential.
- (7) LVDS differential inputs must not exceed the specified limit or damage may result to the internal termination resistors.
- (8) Exposure of the DMD simultaneously to any combination of the maximum operating conditions for case temperature, differential temperature, or illumination power density may affect device reliability.
- (9) DMD Temperature is the worst-case of any test point shown in [Figure 15](#), or the active array as calculated by the *Micromirror Array Temperature Calculation*.

## 7.2 Storage Conditions

applicable before the DMD is installed in the final product

		MIN	MAX	UNIT
T <sub>stg</sub>	Storage temperature	-40	80	°C
	Storage humidity, non-condensing	0%	95%	RH

## 7.3 ESD Ratings

		VALUE	UNIT
V <sub>(ESD)</sub>	Electrostatic discharge Human body model (HBM), per ANSI/ESDA/JEDEC JS-001, all pins <sup>(1)</sup>	±2000	V

(1) JEDEC document JEP155 states that 500-V HBM allows safe manufacturing with a standard ESD control process.

## 7.4 Recommended Operating Conditions

over operating free-air temperature range (unless otherwise noted)

		MIN	NOM	MAX	UNIT		
<b>SUPPLY VOLTAGES</b> <sup>(1) (2)</sup>							
VCC	DLP9000FLS	Supply voltage for LVCMOS core logic		3.0	3.3	3.6	V
	DLP9000XFLS	Supply voltage for LVCMOS core logic		3.3	3.45	3.6	V
VCCI	DLP9000FLS	Supply voltage for LVDS receivers		3.0	3.3	3.6	V
	DLP9000XFLS	Supply voltage for LVDS receivers		3.3	3.45	3.6	V
VOFFSET	Supply voltage for HVCMOS and micromirror electrodes <sup>(3)</sup>		8.25	8.5	8.75	V	
VBIAS	Supply voltage for micromirror electrodes		15.5	16	16.5	V	
VRESET			-9.5	-10	-10.5	V	
VCCI-VCC	Supply voltage delta (absolute value) <sup>(4)</sup>				0.3	V	
VBIAS-VOFFSET	Supply voltage delta (absolute value) <sup>(5)</sup>				8.75	V	
<b>LVCMOS PINS</b>							
V <sub>IH</sub>	High level Input voltage <sup>(6)</sup>		1.7	2.5	VCC + 0.3	V	
V <sub>IL</sub>	Low level Input voltage <sup>(6)</sup>		-0.3		0.7	V	
I <sub>OH</sub>	High level output current at V <sub>OH</sub> = 2.4 V				-20	mA	
I <sub>OL</sub>	Low level output current at V <sub>OL</sub> = 0.4 V				15	mA	
T <sub>PWRDNZ</sub>	PWRDNZ pulse width <sup>(7)</sup>		10			ns	
<b>SCP INTERFACE</b>							
f <sub>clock</sub>	SCP clock frequency <sup>(8)</sup>				500	kHz	
t <sub>SCP_SKEW</sub>	Time between valid SCPDI and rising edge of SCPCLK <sup>(9)</sup>		-800		800	ns	
t <sub>SCP_DELAY</sub>	Time between valid SCPDO and rising edge of SCPCLK <sup>(9)</sup>				700	ns	
t <sub>SCP_BYTE_INTERVAL</sub>	Time between consecutive bytes		1			µs	
t <sub>SCP_NEG_ENZ</sub>	Time between falling edge of SCPENZ and the first rising edge of SCPCLK		30			ns	
t <sub>SCP_PW_ENZ</sub>	SCPENZ inactive pulse width (high level)		1			µs	
t <sub>SCP_OUT_EN</sub>	Time required for SCP output buffer to recover after SCPENZ (from tri-state)				1.5	ns	
f <sub>clock</sub>	SCP circuit clock oscillator frequency <sup>(10)</sup>		9.6		11.1	MHz	

(1) Supply voltages VCC, VCCI, VOFFSET, VBIAS, and VRESET are all required for proper DMD operation. VSS must also be connected.

(2) All voltages are referenced to common ground VSS.

(3) VOFFSET supply transients must fall within specified max voltages.

(4) To prevent excess current, the supply voltage delta |VCCI - VCC| must be less than specified limit.

(5) To prevent excess current, the supply voltage delta |VBIAS - VOFFSET| must be less than specified limit. Refer to [Power Supply Recommendations](#) for additional information.

(6) Tester Conditions for V<sub>IH</sub> and V<sub>IL</sub>:

Frequency = 60MHz. Maximum Rise Time = 2.5 ns at (20% to 80%)

Frequency = 60MHz. Maximum Fall Time = 2.5 ns at (80% to 20%)

(7) PWRDNZ input pin resets the SCP and disables the LVDS receivers. PWRDNZ input pin overrides SCPENZ input pin and tri-states the SCPDO output pin.

(8) The SCP clock is a gated clock. Duty cycle shall be 50% ± 10%. SCP parameter is related to the frequency of DCLK.

(9) Refer to [Figure 1](#).

(10) SCP internal oscillator is specified to operate all SCP registers. For all SCP operations, DCLK is required.

**Recommended Operating Conditions (continued)**

over operating free-air temperature range (unless otherwise noted)

			MIN	NOM	MAX	UNIT
<b>LVDS INTERFACE</b>						
$f_{\text{clock}}$	DLP9000FLS	Clock frequency DCLK			400	MHz
	DLP9000XFLS	Clock frequency DCLK <sup>(11)</sup>	400		480	
$ V_{\text{ID}} $	Input differential voltage (absolute value) <sup>(12)</sup>		100	400	600	mV
$V_{\text{CM}}$	Common mode <sup>(12)</sup>			1200		mV
$V_{\text{LVDS}}$	LVDS voltage <sup>(12)</sup>		0		2000	mV
$t_{\text{LVDS\_RSTZ}}$	Time required for LVDS receivers to recover from PWRDNZ				10	ns
$Z_{\text{IN}}$	Internal differential termination resistance		95		105	$\Omega$
$Z_{\text{LINE}}$	Line differential impedance (PWB/trace)		90	100	110	$\Omega$
<b>ENVIRONMENTAL <sup>(13)</sup> For Illumination Source between 420 and 700 nm</b>						
$T_{\text{DMD}}$	DLP9000FLS	DMD temperature – operational <sup>(14)</sup>	10		40 to 70 <sup>(15)</sup>	$^{\circ}\text{C}$
	DLP9000XFLS	DMD temperature – operational <sup>(14)</sup>	10		40 <sup>(16)</sup>	
$T_{\text{WINDOW}}$	DLP9000FLS	Window temperature – operational			70	$^{\circ}\text{C}$
	DLP9000XFLS	Window temperature – operational			40	
$T_{\text{GRADIENT}}$	Device temperature gradient – operational <sup>(17)</sup>				10	$^{\circ}\text{C}$
$\text{ILL}_{\text{VIS}}$	Illumination				Thermally Limited <sup>(18)</sup>	$\text{mW}/\text{cm}^2$
<b>ENVIRONMENTAL <sup>(13)</sup> For Illumination Source between 400 and 420 nm</b>						
$T_{\text{DMD}}$	DMD temperature – operational <sup>(14)</sup>		20		30	$^{\circ}\text{C}$
$T_{\text{WINDOW}}$	Window temperature – operational				30	$^{\circ}\text{C}$
$T_{\text{GRADIENT}}$	Device temperature gradient – operational <sup>(17)</sup>				10	$^{\circ}\text{C}$
$\text{ILL}_{\text{VIS}}$	Illumination				2.5	$\text{W}/\text{cm}^2$
<b>ENVIRONMENTAL <sup>(13)</sup> For Illumination Source &lt;400 and &gt;700 nm</b>						
$T_{\text{DMD}}$	DLP9000FLS	DMD temperature – operational <sup>(14)</sup>	10		40 to 70 <sup>(15)</sup>	$^{\circ}\text{C}$
	DLP9000XFLS	DMD temperature – operational <sup>(14)</sup>	10		40 <sup>(16)</sup>	
$T_{\text{WINDOW}}$	DLP9000FLS	Window temperature – operational			70	$^{\circ}\text{C}$
	DLP9000XFLS	Window temperature – operational			40	
$T_{\text{GRADIENT}}$	Device temperature gradient – operational <sup>(17)</sup>				10	$^{\circ}\text{C}$
$\text{ILL}_{\text{UV}}$	Illumination, wavelength < 400 nm				0.68	$\text{mW}/\text{cm}^2$
$\text{ILL}_{\text{IR}}$	Illumination, wavelength > 700 nm				10	$\text{mW}/\text{cm}^2$

- (11) The DLP9000X, coupled with the DLPC910, is designed for operation at 2 specific DCLK frequencies only - 400Mhz or 480Mhz. 480Mhz operation is only allowed at the specific environmental operating conditions as shown in this table.
- (12) Refer to [Figure 2](#), [Figure 3](#), and [Figure 4](#).
- (13) Optimal, long-term performance and optical efficiency of the Digital Micromirror Device (DMD) can be affected by various application parameters, including illumination spectrum, illumination power density, micromirror landed duty-cycle, ambient temperature (storage and operating), DMD temperature, ambient humidity (storage and operating), and power on or off duty cycle. TI recommends that application-specific effects be considered as early as possible in the design cycle.
- (14) DMD Temperature is the worst-case of any thermal test point in [Figure 15](#), or the active array as calculated by the [Micromirror Array Temperature Calculation](#).
- (15) Per [Figure 16](#), the maximum operational case temperature should be derated based on the micromirror landed duty cycle that the DMD experiences in the end application. Refer to [Micromirror Landed-On/Landed-Off Duty Cycle](#) for a definition of micromirror landed duty cycle.
- (16) For the DLP9000XFLS, [Figure 16](#) does not apply and the maximum temperature is as specified in table.
- (17) As measured between any two points on the exterior of the package, or as predicted between any two points inside the micromirror array cavity. Refer to [Thermal Information](#) and [Micromirror Array Temperature Calculation](#).
- (18) Refer to [Thermal Information](#) and [Micromirror Array Temperature Calculation](#).

## 7.5 Thermal Information

THERMAL METRIC <sup>(1)</sup>	DLP9000	UNIT
	FLS (CLGA)	
	355 PINS	
R <sub>θJA</sub> Active area-to-case ceramic thermal resistance (max)	0.5	°C/W

- (1) The DMD is designed to conduct absorbed and dissipated heat to the back of the package where it can be removed by an appropriate heat sink. The heat sink and cooling system must be capable of maintaining the package within the temperature range specified in the [Recommended Operating Conditions](#). The total heat load on the DMD is largely driven by the incident light absorbed by the active area; although other contributions include light energy absorbed by the window aperture and electrical power dissipation of the array. Optical systems should be designed to minimize the light energy falling outside the window clear aperture since any additional thermal load in this area can significantly degrade the reliability of the device. .

## 7.6 Electrical Characteristics

over operating free-air temperature range (unless otherwise noted)

PARAMETER	TEST CONDITIONS <sup>(1)</sup>	MIN	TYP	MAX	UNIT
V <sub>OH</sub>	High-level output voltage	VCC = 3 V, I <sub>OH</sub> = –20 mA	2.4		V
V <sub>OL</sub>	Low level output voltage	VCC = 3.6, I <sub>OL</sub> = 15 mA		0.4	V
I <sub>IH</sub>	High-level input current <sup>(2) (3)</sup>	VCC = 3.6 V, V <sub>I</sub> = VCC		250	μA
I <sub>IL</sub>	Low level input current	VCC = 3.6 V, V <sub>I</sub> = 0	–250		μA
I <sub>OZ</sub>	High-impedance output current	VCC = 3.6 V		10	μA
<b>CURRENT</b>					
I <sub>CC</sub>	Supply current <sup>(4)</sup>	DLP9000FLS VCC = 3.6 V, DCLK=400MHz		1600	mA
		DLP9000XFLS VCC = 3.6V, DCLK=480MHz		1850	
I <sub>CCI</sub>		DLP9000FLS VCCI = 3.6 V, DCLK=400MHz		985	
		DLP9000XFLS VCCI = 3.6, DCLK=480MHz		1100	
I <sub>OFFSET</sub>	Supply current <sup>(5)</sup>	V <sub>OFFSET</sub> = 8.75 V		25	mA
I <sub>BIAS</sub>		V <sub>BIAS</sub> = 16.5 V		14	
I <sub>RESET</sub>	Supply current	V <sub>RESET</sub> = –10.5 V		11	mA
I <sub>TOTAL</sub>		DLP9000FLS Total Sum		2634	
		DLP9000XFLS Total Sum		3000	
<b>POWER</b>					
P <sub>CC</sub>	Supply power dissipation	DLP9000FLS VCC = 3.6 V		5760	mW
		DLP9000XFLS VCC = 3.6 V		6660	
P <sub>CCI</sub>		DLP9000FLS VCCI = 3.6 V		3546	mW
		DLP9000XFLS VCCI = 3.6 V		3960	
P <sub>OFFSET</sub>		V <sub>OFFSET</sub> = 8.75 V		219	mW
P <sub>BIAS</sub>		V <sub>BIAS</sub> = 16.5 V		231	mW
P <sub>RESET</sub>		V <sub>RESET</sub> = –10.5 V		115	mW
P <sub>TOTAL</sub>		Supply power dissipation <sup>(6)</sup>	DLP9000FLS Total Sum, DCLK=400MHz		9871
	DLP9000XFLS Total Sum, DCLK=480MHz			11185	
<b>CAPACITANCE</b>					
C <sub>I</sub>	Input capacitance	f = 1 MHz		10	pF
C <sub>O</sub>	Output capacitance	f = 1 MHz		10	pF
	Reset group capacitance MBRST(31:0)	f = 1 MHz ; 2560 × 50 micromirrors	230	290	pF

- (1) All voltages are referenced to common ground VSS. Supply voltages VCC, VCCI, V<sub>OFFSET</sub>, V<sub>BIAS</sub>, and V<sub>RESET</sub> are all required for proper DMD operation. VSS must also be connected.
- (2) Applies to LVCMOS input pins only. Does not apply to LVDS pins and MBRST pins.
- (3) LVCMOS input pins utilize an internal 18000 Ω passive resistor for pull-up and pull-down configurations. Refer to [Pin Configuration and Functions](#) to determine pull-up or pull-down configuration used.
- (4) To prevent excess current, the supply voltage delta |VCCI – VCC| must be less than specified limit.
- (5) To prevent excess current, the supply voltage delta |V<sub>BIAS</sub> – V<sub>OFFSET</sub>| must be less than specified limit.
- (6) Total power on the active micromirror array is the sum of the electrical power dissipation and the absorbed power from the illumination source. See the [Micromirror Array Temperature Calculation](#).

## 7.7 Timing Requirements

 over *Recommended Operating Conditions* (unless otherwise noted) <sup>(1)</sup>

			MIN	NOM	MAX	UNIT	
<b>SCP INTERFACE <sup>(2)</sup></b>							
$t_r$	Rise time	20% to 80%			200	ns	
$t_f$	Fall time	80% to 20%			200	ns	
<b>LVDS INTERFACE <sup>(2)</sup></b>							
$t_r$	Rise time	20% to 80%	100		400	ps	
$t_f$	Fall time	80% to 20%	100		400	ps	
<b>LVDS CLOCKS <sup>(3)</sup></b>							
$t_c$	Cycle time	DLP9000FLS	DCLK_A, 50% to 50%		2.5	ns	
			DCLK_B, 50% to 50%		2.5		
			DCLK_C, 50% to 50%		2.5		
			DCLK_D, 50% to 50%		2.5		
		DLP9000XFLS	DCLK_A, 50% to 50%		2.083		
			DCLK_B, 50% to 50%		2.083		
			DCLK_C, 50% to 50%		2.083		
			DCLK_D, 50% to 50%		2.083		
$t_w$	Pulse duration	DLP9000FLS	DCLK_A, 50% to 50%		1.19	1.25	ns
			DCLK_B, 50% to 50%		1.19	1.25	
			DCLK_C, 50% to 50%		1.19	1.25	
			DCLK_D, 50% to 50%		1.19	1.25	
		DLP9000XFLS	DCLK_A, 50% to 50%		1.031	1.042	
			DCLK_B, 50% to 50%		1.031	1.042	
			DCLK_C, 50% to 50%		1.031	1.042	
			DCLK_D, 50% to 50%		1.031	1.042	
<b>LVDS INTERFACE <sup>(4)</sup></b>							
$t_{su}$	Setup time	D_A(15:0) before rising or falling edge of DCLK_A		0.2	ns		
		D_B(15:0) before rising or falling edge of DCLK_B		0.2			
		D_C(15:0) before rising or falling edge of DCLK_C		0.2			
		D_D(15:0) before rising or falling edge of DCLK_D		0.2			
$t_{su}$	Setup time	SCTRL_A before rising or falling edge of DCLK_A		0.2	ns		
		SCTRL_B before rising or falling edge of DCLK_B		0.2			
		SCTRL_C before rising or falling edge of DCLK_C		0.2			
		SCTRL_D before rising or falling edge of DCLK_D		0.2			
$t_h$	Hold time	DLP9000FLS	D_A(15:0) after rising or falling edge of DCLK_A		0.5	ns	
			D_B(15:0) after rising or falling edge of DCLK_B		0.5		
			D_C(15:0) after rising or falling edge of DCLK_C		0.5		
			D_D(15:0) after rising or falling edge of DCLK_D		0.5		
		DLP9000XFLS	D_A(15:0) after rising or falling edge of DCLK_A		0.4		
			D_B(15:0) after rising or falling edge of DCLK_B		0.4		
			D_C(15:0) after rising or falling edge of DCLK_C		0.4		
			D_D(15:0) after rising or falling edge of DCLK_D		0.4		

 (1) Refer to *Pin Configuration and Functions* for pin details.

 (2) Refer to [Figure 5](#).

 (3) Refer to [Figure 6](#).

 (4) Refer to [Figure 6](#).

## Timing Requirements (continued)

over *Recommended Operating Conditions* (unless otherwise noted) <sup>(1)</sup>

			MIN	NOM	MAX	UNIT		
$t_h$	Hold time	DLP9000FLS	SCTRL_A after rising or falling edge of DCLK_A	0.5			ns	
			SCTRL_B after rising or falling edge of DCLK_B	0.5				
			SCTRL_C after rising or falling edge of DCLK_C	0.5				
			SCTRL_D after rising or falling edge of DCLK_D	0.5				
	DLP9000XFLS	SCTRL_A after rising or falling edge of DCLK_A	0.4					
		SCTRL_B after rising or falling edge of DCLK_B	0.4					
		SCTRL_C after rising or falling edge of DCLK_C	0.4					
		SCTRL_D after rising or falling edge of DCLK_D	0.4					
<b>LVDS INTERFACE <sup>(5)</sup></b>								
$t_{skew}$	Channel B relative to Channel A	DLP9000FLS Channel A includes the following LVDS pairs: DCLK_AP and DCLK_AN SCTRL_AP and SCTRL_AN D_AP(15:0) and D_AN(15:0)		-1.25		1.25	ns	
		DLP9000FLS Channel B includes the following LVDS pairs: DCLK_BP and DCLK_BN SCTRL_BP and SCTRL_BN D_BP(15:0) and D_BN(15:0)						
		DLP9000XFLS Channel A includes the following LVDS pairs: DCLK_AP and DCLK_AN SCTRL_AP and SCTRL_AN D_AP(15:0) and D_AN(15:0)		-1.04		1.04		ns
		DLP9000XFLS Channel B includes the following LVDS pairs: DCLK_BP and DCLK_BN SCTRL_BP and SCTRL_BN D_BP(15:0) and D_BN(15:0)						
	Channel D relative to Channel C	DLP9000FLS Channel C includes the following LVDS pairs: DCLK_CP and DCLK_CN SCTRL_CP and SCTRL_CN D_CP(15:0) and D_CN(15:0)		-1.25		1.25	ns	
		DLP9000FLS Channel D includes the following LVDS pairs: DCLK_DP and DCLK_DN SCTRL_DP and SCTRL_DN D_DP(15:0) and D_DN(15:0)						
		DLP9000XFLS Channel C includes the following LVDS pairs: DCLK_CP and DCLK_CN SCTRL_CP and SCTRL_CN D_CP(15:0) and D_CN(15:0)		-1.04		1.04		ns
		DLP9000XFLS Channel D includes the following LVDS pairs: DCLK_DP and DCLK_DN SCTRL_DP and SCTRL_DN D_DP(15:0) and D_DN(15:0)						

(5) Refer to [Figure 7](#).

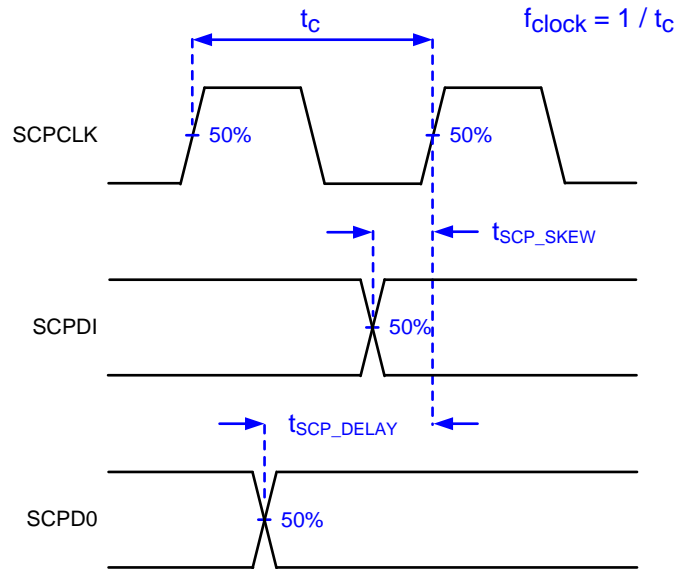

Not to scale.

Refer to SCP Interface section of the Recommended Operating Conditions table.

**Figure 1. SCP Timing Parameters**

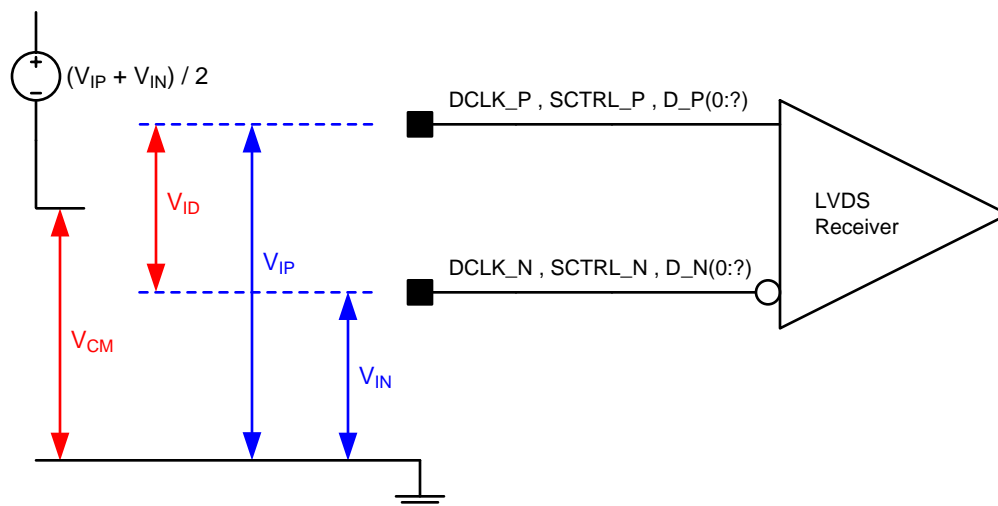

Refer to LVDS Interface section of the Recommended Operating Conditions table.

Refer to Pin Configuration and Functions for list of LVDS pins.

**Figure 2. LVDS Voltage Definitions (References)**

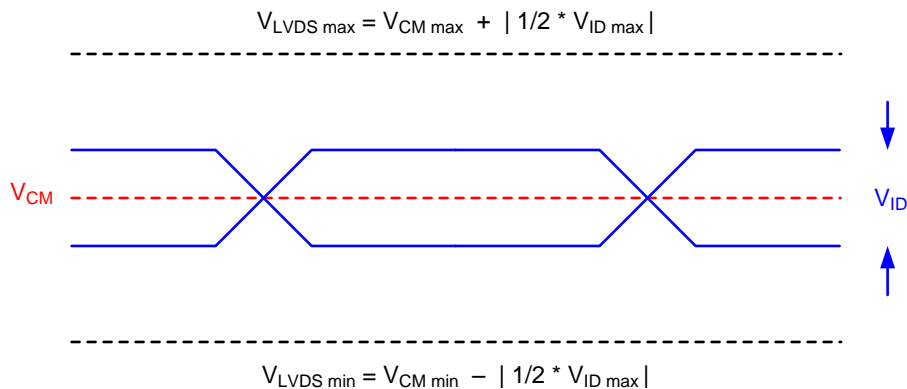

Not to scale.

Refer to LVDS Interface section of the Recommended Operating Conditions table.

**Figure 3. LVDS Voltage Parameters**

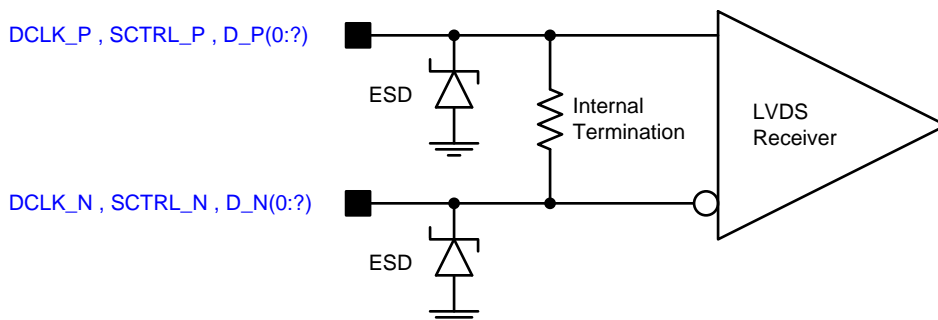

Refer to LVDS Interface section of the Recommended Operating Conditions table.

Refer to Pin Configuration and Functions for list of LVDS pins.

**Figure 4. LVDS Equivalent Input Circuit**

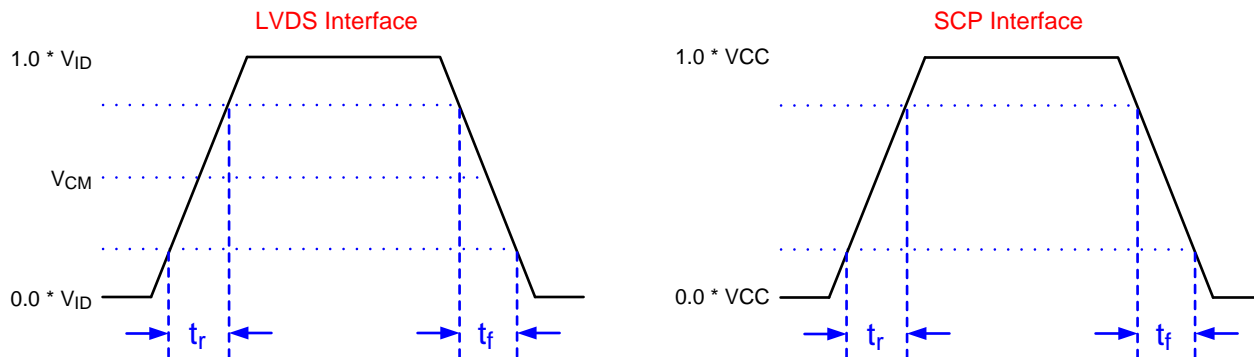

Not to scale.

Refer to the Timing Requirements table

Refer to Pin Configuration and Functions for a list of LVDS pins and SCP pins..

**Figure 5. Rise Time and Fall Time**

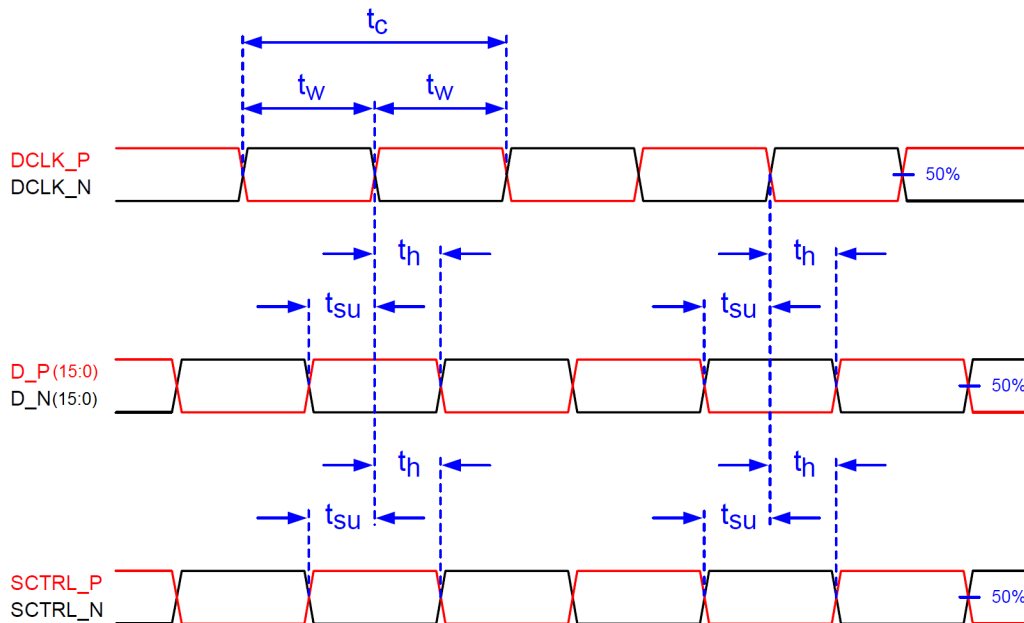

Not to scale.

Refer to LVDS INTERFACE section in the Timing Requirements table.

**Figure 6. Timing Requirement Parameter Definitions**

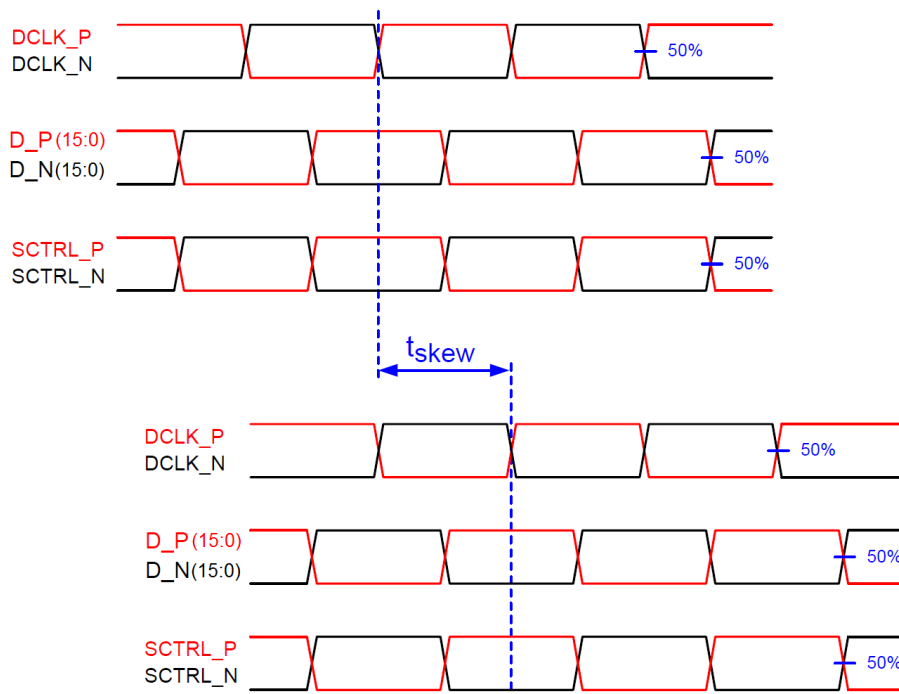

Not to scale.

Refer to LVDS INTERFACE section in the Timing Requirements table.

**Figure 7. LVDS Interface Channel Skew Definition**

## 7.8 Capacitance at Recommended Operating Conditions

over operating free-air temperature range (unless otherwise noted)

PARAMETER		TEST CONDITIONS	MIN	MAX	UNIT
C <sub>I</sub>	Input capacitance	f = 1 MHz		10	pf
C <sub>O</sub>	Output capacitance	f = 1 MHz		10	pf
C <sub>IM</sub>	MBRST(31:0) input capacitance	f = 1 MHz. All inputs interconnected	230	290	pf

## 7.9 Typical Characteristics

The DLP9000FLS DMD is controlled by two DLPC900 controllers. This chipset offers two modes of operation. The first is Video mode where the video source is displayed on the DMD. The second is Pattern mode, where the patterns are pre-stored in flash memory and then streamed to the DMD. The DMD pattern rates are shown in [Table 1](#) and depend on the desired bit depth.

The DLP9000XFLS DMD is controlled by the DLPC910 controller, where the DLPC910 is configured by the configuration data in the DLPR910. This chipset offers streaming 1-bit binary patterns to the DMD at speeds greater than 61 Gigabits per second (Gbps). The patterns are streamed from a customer designed applications processor into the DLPC910 input LVDS data interface. [Table 2](#) shows the pattern rates for the different DMD Reset Modes.

**Table 1. DLP9000FLS Pattern Rates**

BIT DEPTH	MAX PIXEL DATA RATE (Gbps) <sup>(1)</sup>	MAX PATTERN RATE (Hz) <sup>(2)</sup>
1	39.00	9523
2	13.47	3289
3	10.08	2638
4	5.59	1364
5	3.37	823
6	2.75	672
7	2.05	500
8	1.01	247

- (1) Pixel data rates are based on burst operating mode, maximum 400 binary patterns.  
(2) Pattern rates are based on loading the entire DMD in global reset mode. Refer to the DLPC900 data sheet listed in [相关文档](#) regarding operating modes.

**Table 2. DLP9000XFLS Pattern Rates**

RESET MODE <sup>(1)</sup>	MAX PIXEL DATA RATE (Gbps) <sup>(2)</sup>	MAX PATTERN RATE (Hz) <sup>(3)</sup>
Global	53.42	13043 <sup>(4)</sup>
Single	56.46	13783 <sup>(5)</sup>
Dual	59.89	14624 <sup>(5)</sup>
Quad	61.39	14989 <sup>(5)</sup>

- (1) Refer to the DLPC910 data sheet in [相关文档](#) for a description of the reset modes.  
(2) Pixel data rates are based on continuous streaming.  
(3) Increasing exposure periods may be necessary for a desired application but may decrease pattern rate.  
(4) Global reset mode allows for continuous or pulsed illumination source.  
(5) This reset mode typically requires pulsed illumination such as a laser or LED.

### 7.10 System Mounting Interface Loads

PARAMETER		MIN	NOM	MAX	UNIT
Maximum system mounting interface load to be applied to the:	Thermal interface area (See Figure 8)			35	lbs
	Electrical interface area			300	lbs
	Datum A interface area <sup>(1)</sup>			160	lbs

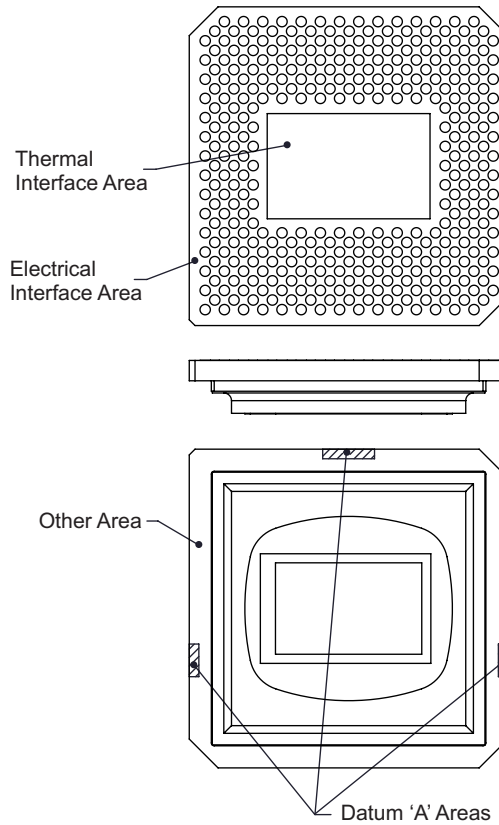

Figure 8. System Mounting Interface Loads

### 7.11 Micromirror Array Physical Characteristics

		VALUE	UNIT
M	Number of active columns	See Figure 9	2560 micromirrors
N	Number of active rows		1600 micromirrors
P	Micromirror (pixel) pitch		7.56 $\mu$ m
	Micromirror active array width $M \times P$		19.3536 mm
	Micromirror active array height $N \times P$		12.096 mm
	Micromirror active border	Pond of micromirror (POM) <sup>(1)</sup>	14 micromirrors/ side
	Micromirror total area	$P^2 \times M \times N$ (converted to cm)	2.341 $cm^2$

(1) Combined loads of the thermal and electrical interface areas in excess of Datum "A" load shall be evenly distributed outside the Datum A area (300 + 35 – Datum A).

(1) The structure and qualities of the border around the active array includes a band of partially functional micromirrors called the POM. These micromirrors are structurally and/or electrically prevented from tilting toward the bright or ON state, but still require an electrical bias to tilt toward OFF.

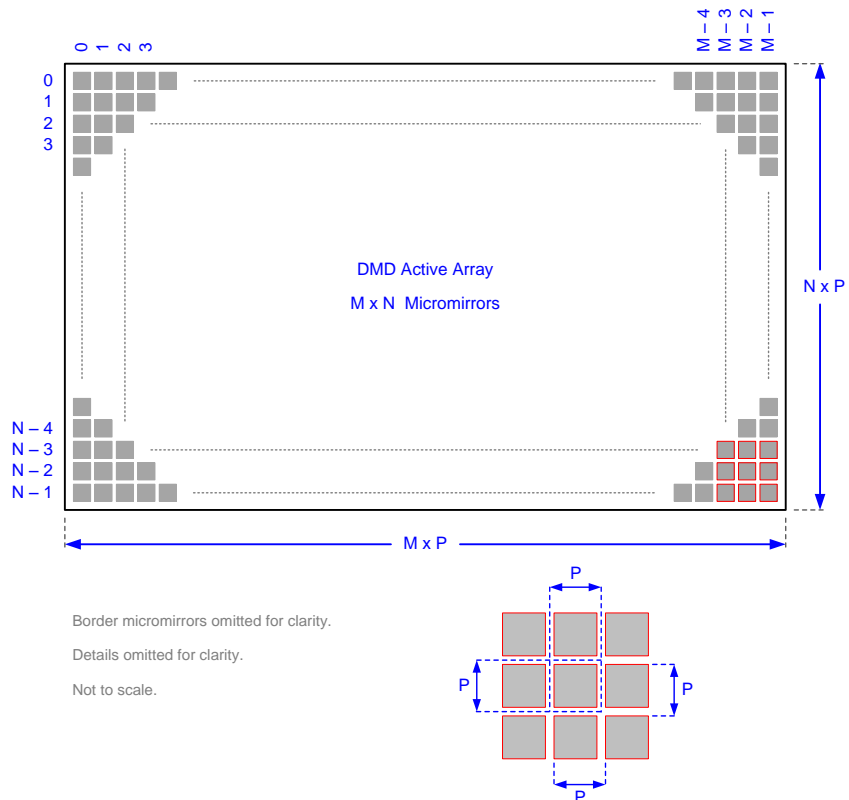

Refer to section *Micromirror Array Physical Characteristics* table for M, N, and P specifications.

**Figure 9. Micromirror Array Physical Characteristics**

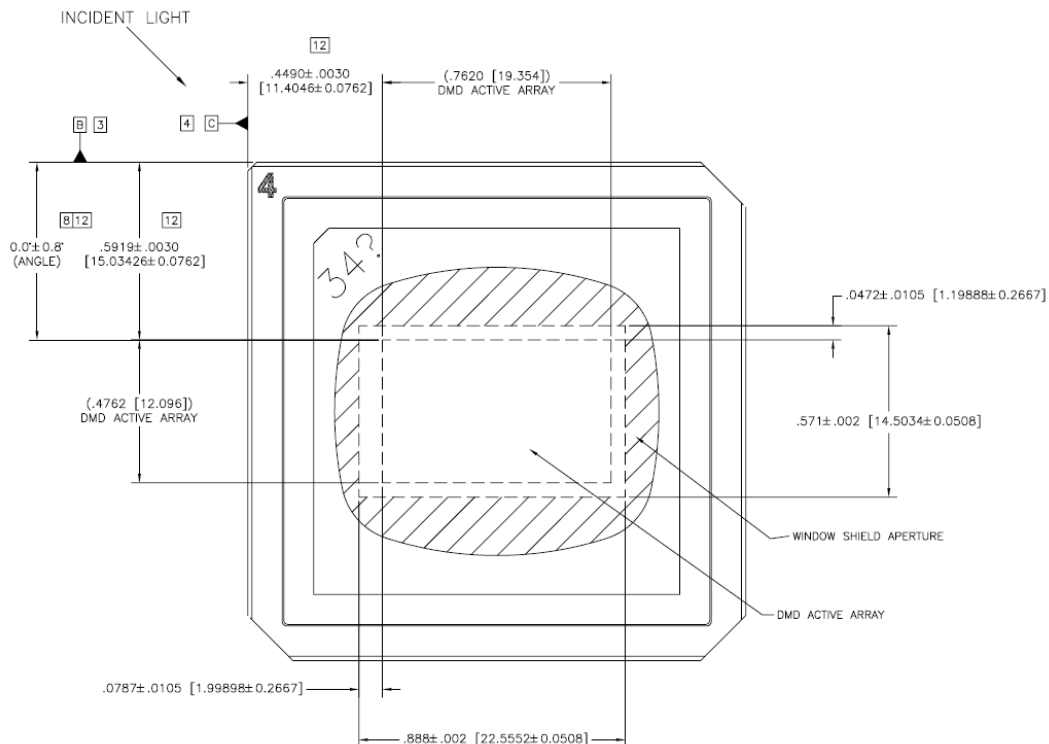

**Figure 10. DMD Micromirror Active Area**

## 7.12 Micromirror Array Optical Characteristics

Refer to [Optical Interface and System Image Quality](#) for important information.

PARAMETER	TEST CONDITIONS	MIN	NOM	MAX	UNIT
$\alpha$ Micromirror tilt angle	DMD landed state <sup>(1)</sup>		12		°
$\beta$ Micromirror tilt angle tolerance <sup>(1)</sup> <sup>(2)</sup> <sup>(3)</sup> <sup>(4)</sup> <sup>(5)</sup>		-1		1	°
Micromirror tilt direction <sup>(5)</sup> <sup>(6)</sup>	See <a href="#">Figure 11</a>	44	45	46	°
Number of out-of-specification micromirrors <sup>(7)</sup>	Adjacent micromirrors				0
	Non-adjacent micromirrors				10
Micromirror crossover time <sup>(8)</sup> <sup>(9)</sup>	Typical performance				2.5
Micromirror switching time <sup>(9)</sup>	Typical performance				5
DMD efficiency within the wavelength range 400 nm to 420 nm <sup>(10)</sup>					68%
DMD photopic efficiency within the wavelength range 420 nm to 700 nm <sup>(10)</sup>					66%

- (1) Measured relative to the plane formed by the overall micromirror array.
- (2) Additional variation exists between the micromirror array and the package datums.
- (3) Represents the landed tilt angle variation relative to the nominal landed tilt angle.
- (4) Represents the variation that can occur between any two individual micromirrors, located on the same device or located on different devices.
- (5) For some applications, it is critical to account for the micromirror tilt angle variation in the overall system optical design. With some system optical designs, the micromirror tilt angle variation within a device may result in perceivable non-uniformities in the light field reflected from the micromirror array. With some system optical designs, the micromirror tilt angle variation between devices may result in colorimetry variations, system efficiency variations or system contrast variations.
- (6) When the micromirror array is landed (not parked), the tilt direction of each individual micromirror is dictated by the binary contents of the CMOS memory cell associated with each individual micromirror. A binary value of 1 results in a micromirror landing in the ON State direction. A binary value of 0 results in a micromirror landing in the OFF State direction.
- (7) An out-of-specification micromirror is defined as a micromirror that is unable to transition between the two landed states within the specified Micromirror Switching Time.
- (8) Micromirror crossover time is primarily a function of the natural response time of the micromirrors.
- (9) Performance as measured at the start of life.
- (10) Efficiency numbers assume 24-degree illumination angle, F/2.4 illumination and collection cones, uniform source spectrum, and uniform pupil illumination. Efficiency numbers assume 100% electronic mirror duty cycle and do not include optical overfill loss. Note that this number is specified under conditions described above and deviations from the specified conditions could result in decreased efficiency.

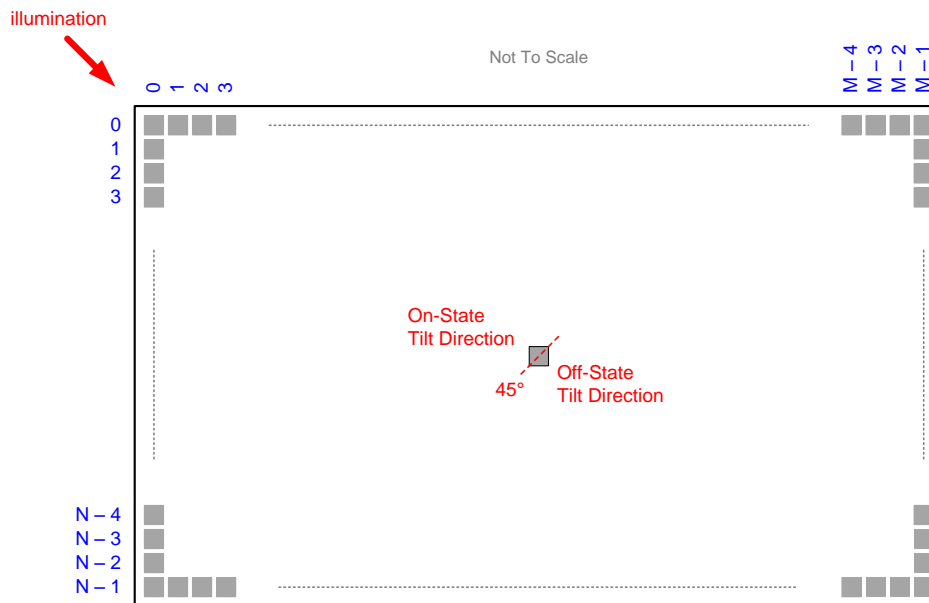

Refer to section [Micromirror Array Physical Characteristics](#) table for M, N, and P specifications.

**Figure 11. Micromirror Landed Orientation and Tilt**

### 7.13 Optical and System Image Quality

Optimizing system optical performance and image quality strongly relate to optical system design parameter trades. Although it is not possible to anticipate every conceivable application, projector image quality and optical performance is contingent on compliance to the optical system operating conditions described in a) through c) below: a) Numerical Aperture and Stray Light Control. The angle defined by the numerical aperture of the illumination and projection optics at the DMD optical area should be the same. This angle should not exceed the nominal device mirror tilt angle unless appropriate apertures are added in the illumination and/or projection pupils to block out flat-state and stray light from the projection lens. The mirror tilt angle defines DMD capability to separate the "ON" optical path from any other light path, including undesirable flat-state specular reflections from the DMD window, DMD border structures, or other system surfaces near the DMD such as prism or lens surfaces. If the numerical aperture exceeds the mirror tilt angle, or if the projection numerical aperture angle is more than two degrees larger than the illumination numerical aperture angle, objectionable artifacts in the display's border and/or active area could occur. b) Pupil Match. TI's optical and image quality specifications assume that the exit pupil of the illumination optics is nominally centered within two degrees of the entrance pupil of the projection optics. Misalignment of pupils can create objectionable artifacts in the display's border and/or active area, which may require additional system apertures to control, especially if the numerical aperture of the system exceeds the pixel tilt angle. c) Illumination Overfill. Overfill light illuminating the area outside the active array can create artifacts from the mechanical features that surround the active array and other surface anomalies that may be visible on the screen. The illumination optical system should be designed to limit light flux incident anywhere outside the active array more than 20 pixels from the edge of the active array on all sides. Depending on the particular system's optical architecture and assembly tolerances, this amount of overfill light on the outside of the active array may still cause artifacts to still be visible. **TI ASSUMES NO RESPONSIBILITY FOR IMAGE QUALITY ARTIFACTS OR DMD FAILURES CAUSED BY OPTICAL SYSTEM OPERATING CONDITIONS EXCEEDING LIMITS DESCRIBED ABOVE.**

### 7.14 Window Characteristics

PARAMETER <sup>(1)</sup>	TEST CONDITIONS	MIN	TYP	MAX	UNIT
Window material designation	Corning 7056				
Window refractive index	at wavelength 589 nm		1.487		
Window aperture	See <sup>(2)</sup>				
Illumination overfill	Refer to <a href="#">Illumination Overfill</a>				
Window transmittance, single-pass through both surfaces and glass <sup>(3)</sup>	At wavelength 405 nm. Applies to 0° and 24° AOI only.	95%			
	Minimum within the wavelength range 420 nm to 680 nm. Applies to all angles 0° to 30° AOI.	97%			
	Average over the wavelength range 420 nm to 680 nm. Applies to all angles 30° to 45° AOI.	97%			

(1) Refer to [Window Characteristics and Optics](#) for more information.

(2) For details regarding the size and location of the window aperture, refer to the package mechanical characteristics listed in the Mechanical ICD in the Mechanical, Packaging, and Orderable Information section.

(3) Refer to the TI application report [DLPA031, Wavelength Transmittance Considerations for DMD Window](#).

### 7.15 Chipset Component Usage Specification

The DMD is a component of one or more DLP® chipsets. Reliable function and operation of the DMD requires that it be used in conjunction with the other components of the applicable DLP® chipset, including those components that contain or implement TI DMD control technology. TI DMD control technology is the TI technology and devices for operating or controlling a DMD.

## 8 Parameter Measurement Information

The data sheet provides timing at the device pin. For output timing analysis, the tester pin electronics and its transmission line effects must be taken into account. [Figure 12](#) shows an equivalent test load circuit for the output under test. The load capacitance value stated is only for characterization and measurement of AC timing signals. This load capacitance value does not indicate the maximum load the device is capable of driving.

Timing reference loads are not intended as a precise representation of any particular system environment or depiction of the actual load presented by a production test. System designers should use IBIS or other simulation tools to correlate the timing reference load to a system environment. Refer to the [Application and Implementation](#) section.

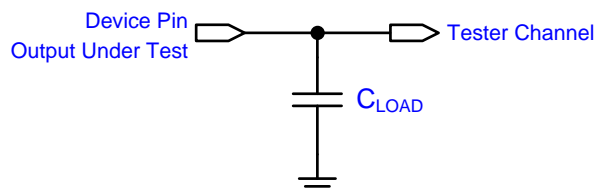

**Figure 12. Test Load Circuit**

## 9 Detailed Description

### 9.1 Overview

The DMD is a 0.9 inch diagonal spatial light modulator which consists of an array of highly reflective aluminum micromirrors. Pixel array size and square grid pixel arrangement are shown in [Figure 9](#).

The DMD is an electrical input, optical output micro-electrical-mechanical system (MEMS). The electrical interface is Low Voltage Differential Signaling (LVDS), Double Data Rate (DDR).

The DMD consists of a two-dimensional array of 1-bit CMOS memory cells. The array is organized in a grid of  $M$  memory cell columns by  $N$  memory cell rows. Refer to the [Functional Block Diagram](#).

The positive or negative deflection angle of the micromirrors can be individually controlled by changing the address voltage of underlying CMOS addressing circuitry and micromirror reset signals (MBRST).

Each cell of the  $M \times N$  memory array drives its true and complement ('Q' and 'QB') data to two electrodes underlying one micromirror, one electrode on each side of the diagonal axis of rotation. Refer to [Micromirror Array Optical Characteristics](#). The micromirrors are electrically tied to the micromirror reset signals (MBRST) and the micromirror array is divided into reset groups.

Electrostatic potentials between a micromirror and its memory data electrodes cause the micromirror to tilt toward the illumination source in a DLP projection system or away from it, thus reflecting its incident light into or out of an optical collection aperture. The positive (+) tilt angle state corresponds to an 'on' pixel, and the negative (-) tilt angle state corresponds to an 'off' pixel.

Refer to [Micromirror Array Optical Characteristics](#) for the  $\pm$  tilt angle specifications. Refer to [Pin Configuration and Functions](#) for more information on micromirror reset control.

## 9.2 Functional Block Diagram

Not to Scale. Details Omitted for Clarity. See Accompanying Notes in this Section.

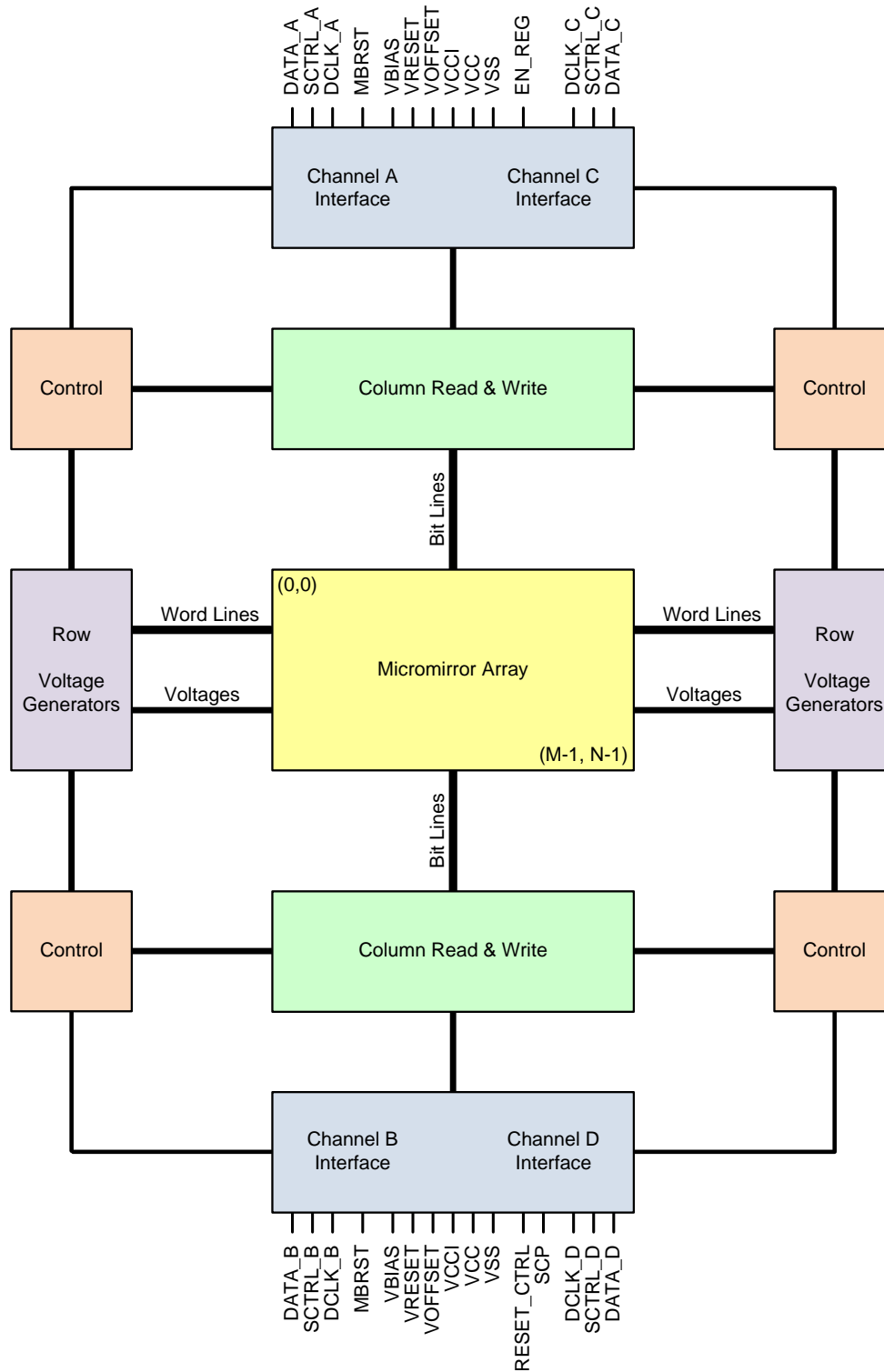

For pin details on Channels A, B, C, and D, refer to [Pin Configuration and Functions](#) and LVDS Interface section of [Timing Requirements](#).

### 9.3 Feature Description

The DMD consists of 4096000 highly reflective, digitally switchable, micrometer-sized mirrors (micromirrors) organized in a two-dimensional orthogonal pixel array. Refer to [Figure 9](#) and [Figure 13](#).

Each aluminum micromirror is switchable between two discrete angular positions,  $-\alpha$  and  $+\alpha$ . The angular positions are measured relative to the micromirror array plane, which is parallel to the silicon substrate. Refer to [Micromirror Array Optical Characteristics](#) and [Figure 14](#).

The parked position of the micromirror is not a latched position and is therefore not necessarily perfectly parallel to the array plane. Individual micromirror flat state angular positions may vary. Tilt direction of the micromirror is perpendicular to the hinge-axis. The on-state landed position is directed toward the left-top edge of the package, as shown in [Figure 13](#).

Each individual micromirror is positioned over a corresponding CMOS memory cell. The angular position of a specific micromirror is determined by the binary state (logic 0 or 1) of the corresponding CMOS memory cell contents, after the mirror clocking pulse is applied. The angular position ( $-\alpha$  and  $+\alpha$ ) of the individual micromirrors changes synchronously with a micromirror clocking pulse, rather than being coincident with the CMOS memory cell data update.

Writing logic 1 into a memory cell followed by a mirror clocking pulse results in the corresponding micromirror switching to a  $+\alpha$  position. Writing logic 0 into a memory cell followed by a mirror clocking pulse results in the corresponding micromirror switching to a  $-\alpha$  position.

Updating the angular position of the micromirror array consists of two steps. First, update the contents of the CMOS memory. Second, apply a micromirror reset (also referred as Mirror Clocking Pulse) to all or a portion of the micromirror array (depending upon the configuration of the system). Micromirror reset pulses are generated internally by the DMD, with application of the pulses being coordinated by the DLPC900 or the DLPC910 digital controller.

For more information, refer to the TI application report [DLPA008](#), *DMD101: Introduction to Digital Micromirror Device (DMD) Technology*.

Feature Description (continued)

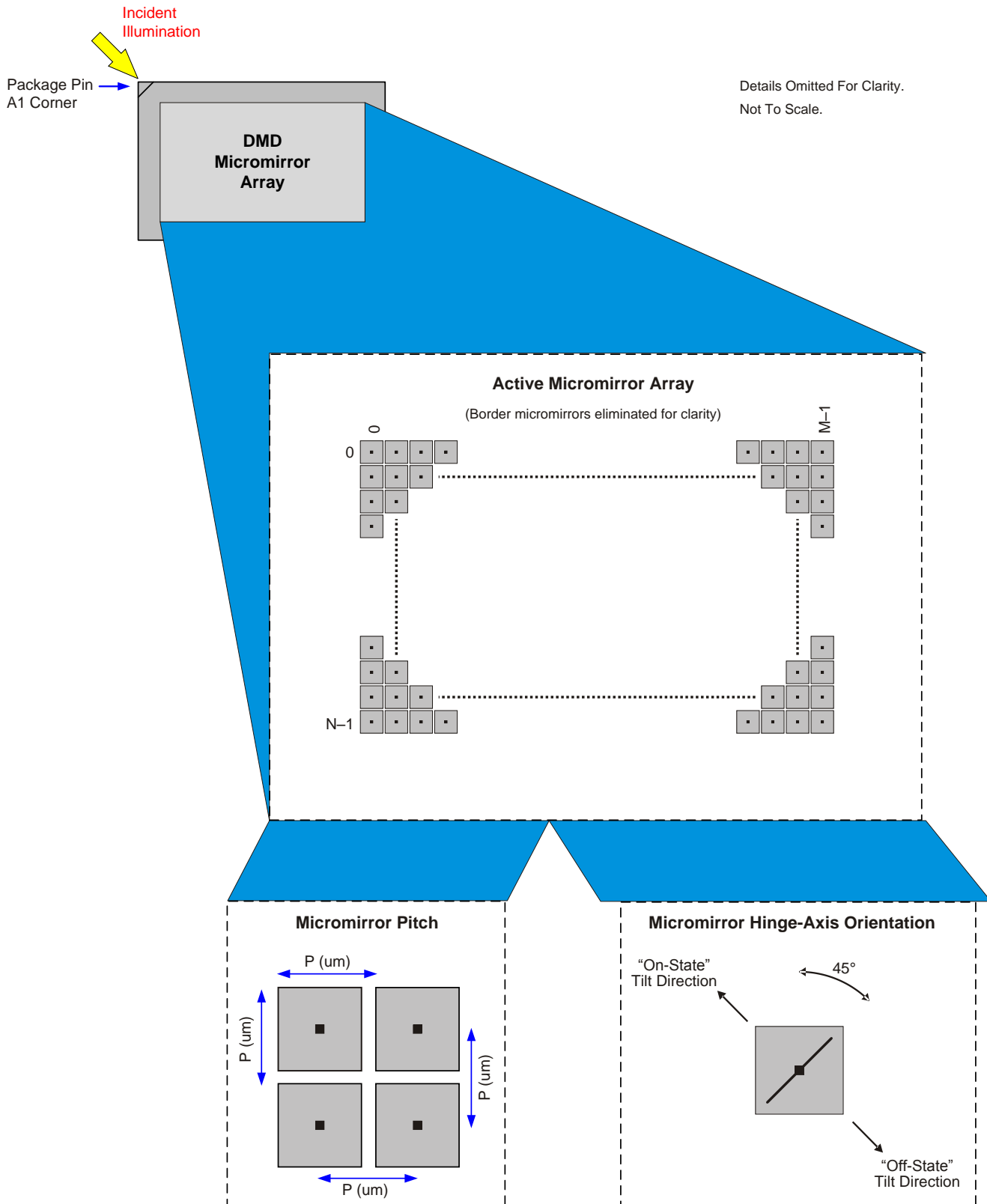

Refer to *Micromirror Array Physical Characteristics*, Figure 9, and Figure 11.

Figure 13. Micromirror Array, Pitch, Hinge Axis Orientation

Feature Description (continued)

Details Omitted For Clarity.  
Not To Scale.

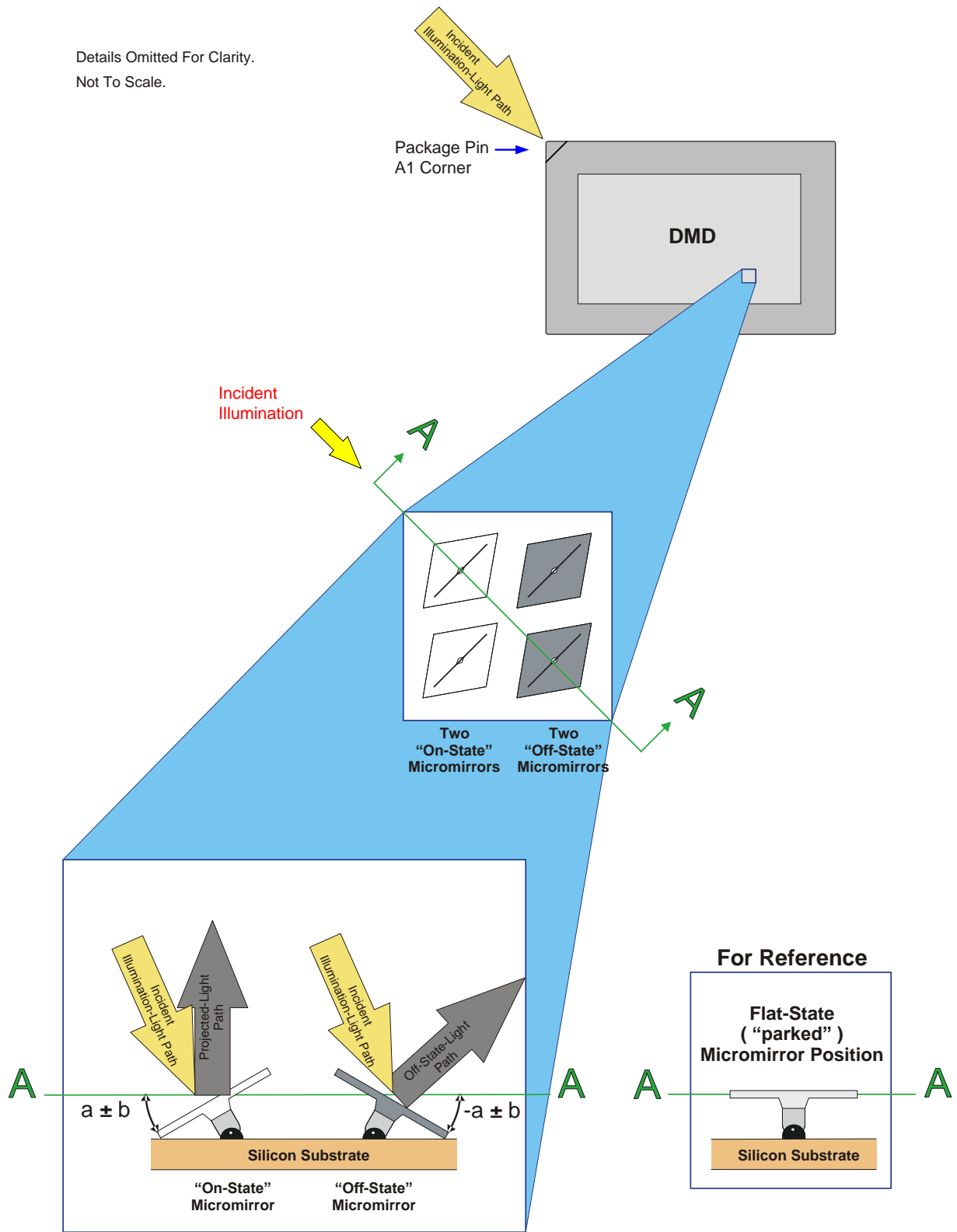

Micromirror States: On, Off, Flat

Figure 14. Micromirror States: On, Off, Flat

## 9.4 Device Functional Modes

### 9.4.1 DLP9000FLS

The DLP9000FLS DMD is controlled by two DLPC900 digital controllers. These controllers have two modes of operation. The first is Video mode where the video source is displayed on the DMD. The second is Pattern mode, where the patterns are pre-stored in flash memory and then streamed to the DMD. The resulting DMD pattern rate depends on which mode and bit-depth is selected. For more information, refer to the DLPC900 data sheet listed under [相关文档](#).

### 9.4.2 DLP9000XFLS

The DLP9000XFLS DMD is controlled by one DLPC910 digital controller. The digital controller offers high speed streaming mode where 1-bit binary patterns are accepted at the LVDS interface input, and then streamed to the DMD. To ensure reliable operation, the DLP9000XFLS must always be used with the DLPC910. For more information, refer to the DLPC910 data sheet listed under [相关文档](#).

## 9.5 Window Characteristics and Optics

---

### NOTE

TI assumes no responsibility for image quality artifacts or DMD failures caused by optical system operating conditions exceeding limits described previously.

---

### 9.5.1 Optical Interface and System Image Quality

TI assumes no responsibility for end-equipment optical performance. Achieving the desired end-equipment optical performance involves making trade-offs between numerous component and system design parameters. Optimizing system optical performance and image quality strongly relate to optical system design parameter trades. Although it is not possible to anticipate every conceivable application, projector image quality and optical performance is contingent on compliance to the optical system operating conditions described in the following sections.

### 9.5.2 Numerical Aperture and Stray Light Control

The angle defined by the numerical aperture of the illumination and projection optics at the DMD optical area should be the same. This angle should not exceed the nominal device mirror tilt angle unless appropriate apertures are added in the illumination and/or projection pupils to block out flat-state and stray light from the projection lens. The mirror tilt angle defines DMD capability to separate the "ON" optical path from any other light path, including undesirable flat-state specular reflections from the DMD window, DMD border structures, or other system surfaces near the DMD such as prism or lens surfaces. If the numerical aperture exceeds the mirror tilt angle, or if the projection numerical aperture angle is more than two degrees larger than the illumination numerical aperture angle, objectionable artifacts in the display's border and/or active area could occur.

### 9.5.3 Pupil Match

TI's optical and image quality specifications assume that the exit pupil of the illumination optics is nominally centered within 2° (two degrees) of the entrance pupil of the projection optics. Misalignment of pupils can create objectionable artifacts in the display's border and/or active area, which may require additional system apertures to control, especially if the numerical aperture of the system exceeds the pixel tilt angle.

### 9.5.4 Illumination Overfill

The active area of the device is surrounded by an aperture on the inside DMD window surface that masks structures of the DMD device assembly from normal view. The aperture is sized to anticipate several optical operating conditions. Overfill light illuminating the window aperture can create artifacts from the edge of the window aperture opening and other surface anomalies that may be visible on the screen. The illumination optical system should be designed to limit light flux incident anywhere on the window aperture from exceeding approximately 10% of the average flux level in the active area. Depending on the particular system's optical architecture, overfill light may have to be further reduced below the suggested 10% level in order to be acceptable.

## 9.6 Micromirror Array Temperature Calculation

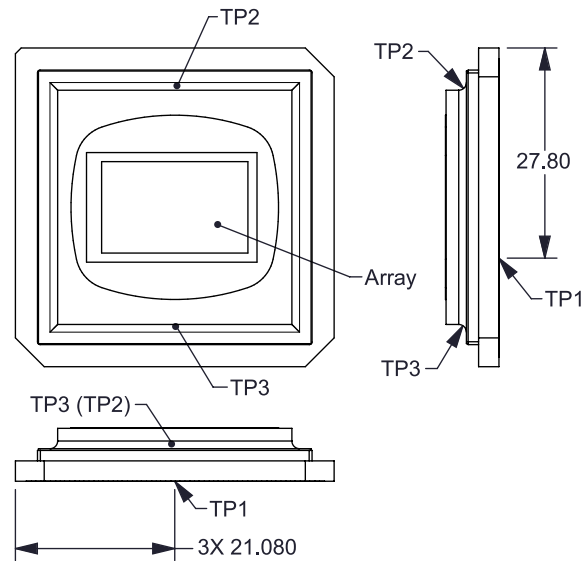

**Figure 15. DMD Thermal Test Points**

Micromirror array temperature can be computed analytically from measurement points on the outside of the package, the ceramic package thermal resistance, the electrical power dissipation, and the illumination heat load. The relationship between micromirror array temperature and the reference ceramic temperature is provided by the following equations:

$$T_{\text{ARRAY}} = T_{\text{CERAMIC}} + (Q_{\text{ARRAY}} \times R_{\text{ARRAY-TO-CERAMIC}}) \quad (1)$$

$$Q_{\text{ARRAY}} = Q_{\text{ELECTRICAL}} + Q_{\text{ILLUMINATION}} \quad (2)$$

$$Q_{\text{ILLUMINATION}} = (C_{\text{L2W}} \times \text{SL}) \quad (3)$$

Where:

$T_{\text{ARRAY}}$  = Computed micromirror array temperature (°C)

$T_{\text{CERAMIC}}$  = Measured ceramic temperature (°C), TP1 location in [Figure 15](#)

$R_{\text{ARRAY-TO-CERAMIC}}$  = DMD package thermal resistance from micromirror array to outside ceramic (°C/W) specified in [Thermal Information](#)

$Q_{\text{ARRAY}}$  = Total DMD power; electrical, specified in [Electrical Characteristics](#), plus absorbed (calculated) (W)

$Q_{\text{ELECTRICAL}}$  = DMD electrical power dissipation (W), specified in [Electrical Characteristics](#)

$C_{\text{L2W}}$  = Conversion constant for screen lumens to absorbed optical power on the DMD (W/lm) specified below

SL = Measured ANSI screen lumens (lm)

Electrical power dissipation of the DMD is variable and depends on the voltages, data rates and operating frequencies. Absorbed optical power from the illumination source is variable and depends on the operating state of the micromirrors and the intensity of the light source. Equations shown above produce a total projection efficiency through the projection lens from DMD to the screen of 87%.

The conversion constant  $C_{\text{L2W}}$  is based on the DMD micromirror array characteristics. It assumes a spectral efficiency of 300 lm/W for the projected light and illumination distribution of 83.7% on the DMD active array, and 16.3% on the DMD array border and window aperture. The conversion constant is calculated to be 0.00293 W/lm.

Sample Calculation for typical projection application:

$T_{\text{CERAMIC}} = 55^{\circ}\text{C}$ , assumed system measurement; refer to [Recommended Operating Conditions](#) regarding specific limits.

SL = 2000 lm

$Q_{\text{ELECTRICAL}} = 9.87\text{W}$  for the DLP9000FLS (refer to the power specifications in [Electrical Characteristics](#))

$C_{\text{L2W}} = 0.00293\text{ W/lm}$

## Micromirror Array Temperature Calculation (continued)

$$Q_{\text{ARRAY}} = 9.87 \text{ W} + (0.00293 \text{ W/lm} \times 2000 \text{ lm}) = 15.73 \text{ W}$$

$$T_{\text{ARRAY}} = 55^{\circ}\text{C} + (15.73 \text{ W} \times 0.5 \text{ }^{\circ}\text{C/W}) = 62.87^{\circ}\text{C}$$

### 9.7 Micromirror Landed-On/Landed-Off Duty Cycle

#### 9.7.1 Definition of Micromirror Landed-On/Landed-Off Duty Cycle

The micromirror landed-on/landed-off duty cycle (landed duty cycle) denotes the amount of time (as a percentage) that an individual micromirror is landed in the On-state versus the amount of time the same micromirror is landed in the Off-state.

As an example, a landed duty cycle of 100/0 indicates that the referenced pixel is in the On-state 100% of the time (and in the Off-state 0% of the time); whereas 0/100 would indicate that the pixel is in the Off-state 100% of the time. Likewise, 50/50 indicates that the pixel is On 50% of the time and Off 50% of the time.

Note that when assessing landed duty cycle, the time spent switching from one state (ON or OFF) to the other state (OFF or ON) is considered negligible and is thus ignored.

Since a micromirror can only be landed in one state or the other (On or Off), the two numbers (percentages) always add to 100.

#### 9.7.2 Landed Duty Cycle and Useful Life of the DMD

Knowing the long-term average landed duty cycle (of the end product or application) is important because subjecting all (or a portion) of the DMD's micromirror array (also called the active array) to an asymmetric landed duty cycle for a prolonged period of time can reduce the DMD's usable life.

Note that it is the symmetry/asymmetry of the landed duty cycle that is of relevance. The symmetry of the landed duty cycle is determined by how close the two numbers (percentages) are to being equal. For example, a landed duty cycle of 50/50 is perfectly symmetrical whereas a landed duty cycle of 100/0 or 0/100 is perfectly asymmetrical.

#### 9.7.3 Landed Duty Cycle and Operational DMD Temperature

Operational DMD Temperature and Landed Duty Cycle interact to affect the DMD's usable life, and this interaction can be exploited to reduce the impact that an asymmetrical Landed Duty Cycle has on the DMD's usable life. This is quantified in the de-rating curve shown in [Figure 16](#). The importance of this curve is that:

- All points along this curve represent the same usable life.
- All points above this curve represent lower usable life (and the further away from the curve, the lower the usable life).
- All points below this curve represent higher usable life (and the further away from the curve, the higher the usable life).

In practice, this curve specifies the Maximum Operating DMD Temperature that the DMD should be operated at for a given long-term average Landed Duty Cycle.

**Micromirror Landed-On/Landed-Off Duty Cycle (continued)**

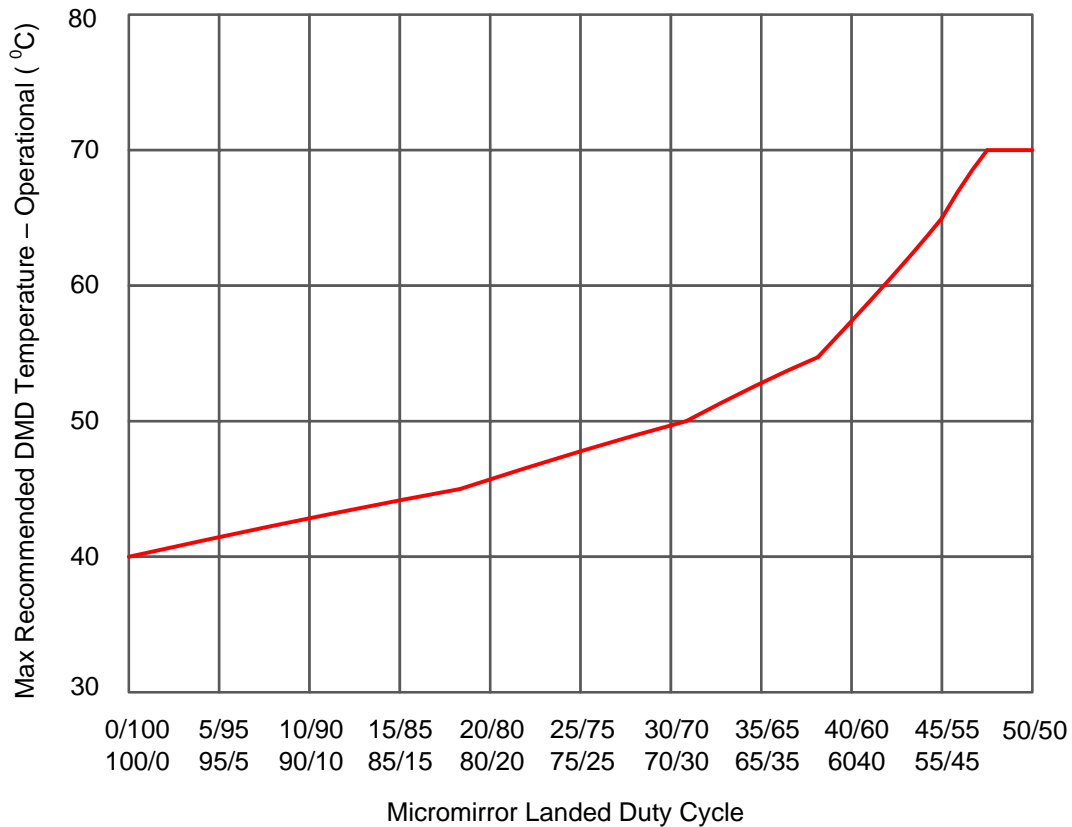

**Figure 16. Max Recommended DMD Temperature – Derating Curve**

**9.7.4 Estimating the Long-Term Average Landed Duty Cycle of a Product or Application**

During a given period of time, the Landed Duty Cycle of a given pixel follows from the image content being displayed by that pixel.

For example, in the simplest case, when displaying pure-white on a given pixel for a given time period, that pixel will experience a 100/0 Landed Duty Cycle during that time period. Likewise, when displaying pure-black, the pixel will experience a 0/100 Landed Duty Cycle.

Between the two extremes (ignoring for the moment color and any image processing that may be applied to an incoming image), the Landed Duty Cycle tracks one-to-one with the gray scale value, as shown in Table 3.

**Table 3. Grayscale Value and Landed Duty Cycle**

GRAYSCALE VALUE	LANDED DUTY CYCLE
0%	0/100
10%	10/90
20%	20/80
30%	30/70
40%	40/60
50%	50/50
60%	60/40
70%	70/30
80%	80/20
90%	90/10
100%	100/0

Accounting for color rendition (but still ignoring image processing) requires knowing both the color intensity (from 0% to 100%) for each constituent primary color (red, green, and/or blue) for the given pixel as well as the color cycle time for each primary color, where “color cycle time” is the total percentage of the frame time that a given primary must be displayed in order to achieve the desired white point.

During a given period of time, the landed duty cycle of a given pixel can be calculated as follows:

$$\text{Landed Duty Cycle} = (\text{Red\_Cycle\_}\% \times \text{Red\_Scale\_Value}) + (\text{Green\_Cycle\_}\% \times \text{Green\_Scale\_Value}) + (\text{Blue\_Cycle\_}\% \times \text{Blue\_Scale\_Value})$$

Where:

Red\_Cycle\_%, Green\_Cycle\_%, and Blue\_Cycle\_%, represent the percentage of the frame time that Red, Green, and Blue are displayed (respectively) to achieve the desired white point.

For example, assume that the red, green and blue color cycle times are 50%, 20%, and 30% respectively (in order to achieve the desired white point), then the Landed Duty Cycle for various combinations of red, green, blue color intensities would be as shown in [Table 4](#).

**Table 4. Example Landed Duty Cycle for Full-Color**

RED CYCLE PERCENTAGE 50%	GREEN CYCLE PERCENTAGE 20%	BLUE CYCLE PERCENTAGE 30%	LANDED DUTY CYCLE
RED SCALE VALUE	GREEN SCALE VALUE	BLUE SCALE VALUE	
0%	0%	0%	0/100
100%	0%	0%	50/50
0%	100%	0%	20/80
0%	0%	100%	30/70
12%	0%	0%	6/94
0%	35%	0%	7/93
0%	0%	60%	18/82
100%	100%	0%	70/30
0%	100%	100%	50/50
100%	0%	100%	80/20
12%	35%	0%	13/87
0%	35%	60%	25/75
12%	0%	60%	24/76
100%	100%	100%	100/0

## 10 Application and Implementation

### NOTE

Information in the following applications sections is not part of the TI component specification, and TI does not warrant its accuracy or completeness. TI's customers are responsible for determining suitability of components for their purposes. Customers should validate and test their design implementation to confirm system functionality.

### 10.1 Application Information

The DLP9000FLS DMD is controlled by two DLPC900 controllers. This chipset offers two modes of operation. The first is Video mode where the video source is displayed on the DMD. The second is Pattern mode, where the patterns are pre-stored in flash memory and then streamed to the DMD. The allowed DMD pattern rate depends on which mode and bit-depth is selected.

The DLP9000XFLS DMD is controlled by the DLPC910 controller, where the DLPC910 is configured by the program content in the DLPR910. This chipset offers streaming 1-bit binary patterns to the DMD at speeds greater than 61 Gigabits per second (Gbps). The patterns are streamed from a customer designed processor into the DLPC910 LVDS input data interface.

Both the DLP9000FLS and the DLP9000XFLS provide solutions for many varied applications including structured light, 3-D printing, video projection, and high speed lithography. The DMD is a spatial light modulator, which reflects incoming light from an illumination source to one of two directions, with the primary direction being into a projection or collection optic. Each application is derived primarily from the optical architecture of the system and the format of the data being used.

### 10.2 Typical Applications

#### 10.2.1 Typical Application using DLP9000FLS

A typical embedded system application using two DLPC900 controllers and a DLP9000FLS DMD is shown in [Figure 17](#). In this configuration, the DLPC900 controller supports a 24-bit parallel RGB input, typical of LCD interfaces, from an external source or processor. The 24-bit parallel data must be split between a left half and a right half, each half between the two controllers. The external processor must format each half to consist of 1280x1600 plus any horizontal and vertical blanking at half the pixel clock rate. This system configuration supports still and motion video as well as sequential pattern modes. For more information, refer to the DLPC900 digital controller data sheet listed under [相关文档](#).

Typical Applications (continued)

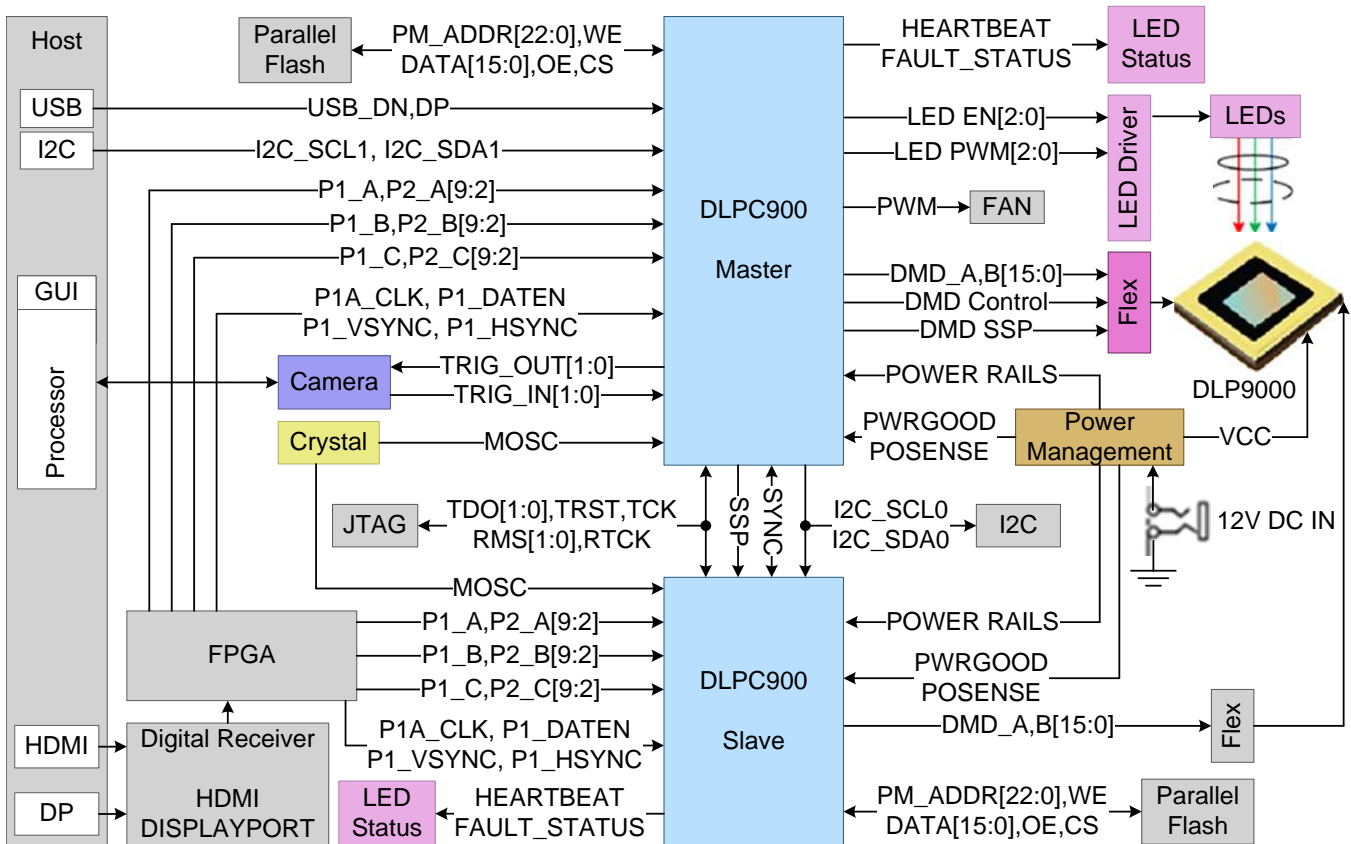

Figure 17. DLP9000FLS Typical Application Schematic

10.2.1.1 Design Requirements

Detailed design requirements are located in the DLPC900 or the DLPC910 digital controller data sheets. Refer to the data sheets listed under [相关文档](#).

10.2.1.2 Detailed Design Procedure

Reference Design material exists for systems using either the DLP9000FLS or the DLP9000XFLS DMD with their respective Controllers. This reference material includes reference board schematics, PCB layouts, and Bills of Materials. Layout guidelines for boards utilizing these controllers and DMDs can be found in the respective DLPC900 or DLPC910 Controller data sheets. For more information, please refer to the individual controller data sheets listed under [相关文档](#).

10.2.2 Typical Application using DLP9000XFLS

Direct-write digital imaging is regularly used in high-end lithography printing. This mask-less technology offers a continuous run of printing by changing the digitally created patterns without stopping the imaging head. [Figure 18](#) shows a system where a DLPC910 digital controller is coupled with the DLP9000XFLS DMD. This system offers an ideal back-end imager that takes in digital images at 2560 x 1600 in resolution to achieve speeds of more than 61 Gbps. For more information, refer to the DLPC910 digital controller data sheet listed under [相关文档](#).

Typical Applications (continued)

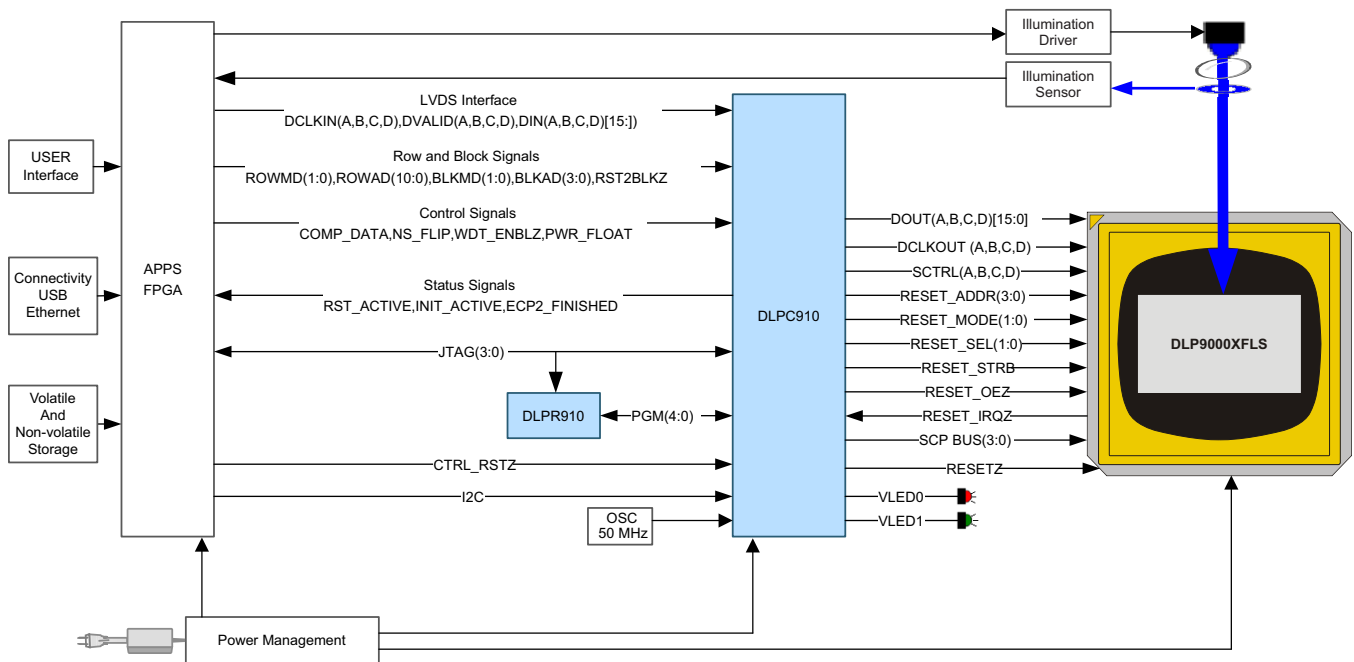

Figure 18. DLP9000XFLS Typical Application Schematic

## 11 Power Supply Recommendations

### 11.1 DMD Power Supply Requirements

The following power supplies are all required to operate the DMD: VCC, VCCI, VOFFSET, VBIAS, and VRESET. VSS must also be connected. DMD power-up and power-down sequencing is strictly controlled by the DLPC900 or DLPC910 Controllers within their associated reference designs.

#### CAUTION

For reliable operation of the DMD, the following power supply sequencing requirements must be followed. Failure to adhere to the prescribed power-up and power-down procedures may affect device reliability. VCC, VCCI, VOFFSET, VBIAS, and VRESET power supplies have to be coordinated during power-up and power-down operations. VSS must also be connected. Failure to meet any of the below requirements will result in a significant reduction in the DMD's reliability and lifetime. Refer to [Figure 19](#).

### 11.2 DMD Power Supply Power-Up Procedure

- During power-up, VCC and VCCI must always start and settle before VOFFSET, VBIAS, and VRESET voltages are applied to the DMD.
- During power-up, it is a strict requirement that the delta between VBIAS and VOFFSET must be within the specified limit shown in [Recommended Operating Conditions](#). *During power-up, VBIAS does not have to start after VOFFSET.*
- During power-up, there is no requirement for the relative timing of VRESET with respect to VOFFSET and VBIAS.
- Power supply slew rates requirements during power-up are flexible, provided that the transient voltage levels follow the requirements listed in [Absolute Maximum Ratings](#), in [Recommended Operating Conditions](#), and in [Figure 19](#).
- During power-up, LVCMOS input pins shall not be driven high until after VCC and VCCI have settled at operating voltages listed in [Recommended Operating Conditions](#).

### 11.3 DMD Power Supply Power-Down Procedure

- During power-down, VCC and VCCI must be supplied until after VBIAS, VRESET, and VOFFSET are discharged to within the specified limit of ground. Refer to [Table 5](#).
- During power-down, it is a strict requirement that the delta between VBIAS and VOFFSET must be within the specified limit shown in [Recommended Operating Conditions](#). During power-down, it is not mandatory to stop driving VBIAS prior to VOFFSET.
- During power-down, there is no requirement for the relative timing of VRESET with respect to VOFFSET and VBIAS.
- Power supply slew rates during power-down are flexible, provided that the transient voltage levels follow the requirements listed in [Absolute Maximum Ratings](#), in [Recommended Operating Conditions](#), and in [Figure 19](#).
- During power-down, LVCMOS input pins must be less than specified in [Recommended Operating Conditions](#).

DMD Power Supply Power-Down Procedure (continued)

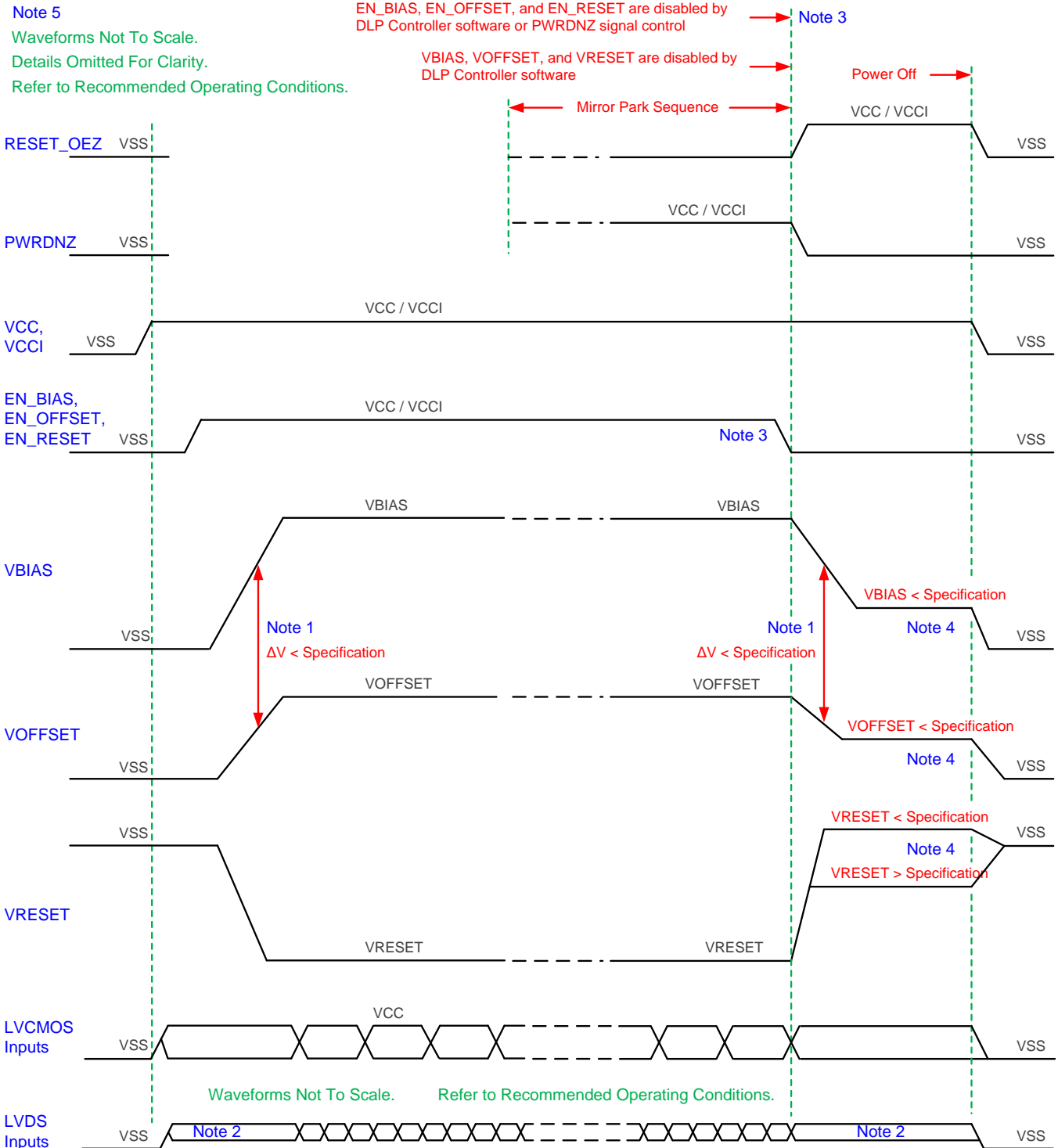

Figure 19. DMD Power Supply Sequencing Requirements

1. To prevent excess current, the supply voltage delta  $|VBIAS - VOFFSET|$  must be less than specified in *Recommended Operating Conditions*. OEMs may find that the most reliable way to ensure this is to power VOFFSET prior to VBIAS during power-up and to remove VBIAS prior to VOFFSET during power-down.
2. During power-up, the LVDS signals are less than the input differential voltage (VID) maximum specified in

**DMD Power Supply Power-Down Procedure (continued)**

*Recommended Operating Conditions.* During power-down, LVDS signals are less than the high level input voltage (VIH) maximum specified in *Recommended Operating Conditions*.

3. When system power is interrupted, the DLPC900 and the DLPC910 controllers initiate a hardware power-down that activates PWRDNZ and disables VBIAS, VRESET and VOFFSET after the micromirror park sequence. Software power-down disables VBIAS, VRESET, and VOFFSET after the micromirror park sequence through software control. For either case, enable signals EN\_BIAS, EN\_OFFSET, and EN\_RESET are used to disable VBIAS, VOFFSET, and VRESET, respectfully.
4. Refer to [Table 5](#).
5. Figure not to scale. Details have been omitted for clarity. Refer to *Recommended Operating Conditions*.

**Table 5. DMD Power-Down Sequence Requirements**

PARAMETER		MIN	MAX	UNIT
VBIAS	Supply voltage level during power-down sequence		4.0	V
VOFFSET			4.0	V
VRESET		-4.0	0.5	V

## 12 Layout

### 12.1 Layout Guidelines

Each chipset provides a solution for many applications including structured light and video projection. This section provides layout guidelines for the DMD.

#### 12.1.1 General PCB Recommendations

The PCB shall be designed to IPC2221 and IPC2222, Class 2, Type Z, at level B producibility and built to IPC6011 and IPC6012, class 2. The PCB board thickness to be 0.062 inches  $\pm 10\%$ , using a dielectric material with a low Loss-Tangent, for example: Hitachi 679gs or equivalent.

Two-ounce copper planes are recommended in the PCB design in order to achieve needed thermal connectivity. Refer to the digital controller data sheets listed under [相关文档](#) regarding DMD Interface Considerations.

High-speed interface waveform quality and timing on the digital controllers (that is, the LVDS DMD interface) is dependent on the following factors:

- Total length of the interconnect system
- Spacing between traces
- Characteristic impedance
- Etch losses
- How well matched the lengths are across the interface

Thus, ensuring positive timing margin requires attention to many factors.

As an example, DMD interface system timing margin can be calculated as follows:

- Setup Margin = (controller output setup) – (DMD input setup) – (PCB routing mismatch) – (PCB SI degradation)
- Hold-time Margin = (controller output hold) – (DMD input hold) – (PCB routing mismatch) – (PCB SI degradation)

The PCB SI degradation is the signal integrity degradation due to PCB affects which includes such things as simultaneously switching output (SSO) noise, crosstalk, and inter-symbol-interference (ISI) noise.

Both the DLPC910 and the DLPC900 I/O timing parameters can be found in their respective data sheets. Similarly, PCB routing mismatch can be easily budgeted and met via controlled PCB routing. However, PCB SI degradation is not as easy to determine.

In an attempt to minimize the signal integrity analysis that would otherwise be required, the following PCB design guidelines provide a reference of an interconnect system that satisfies both waveform quality and timing requirements (accounting for both PCB routing mismatch and PCB SI degradation). Deviation from these recommendations should be confirmed with PCB signal integrity analysis or lab measurements.

#### 12.1.2 Power Planes

Signal routing is NOT allowed on the power and ground planes. All device pin and via connections to this plane shall use a thermal relief with a minimum of four spokes. The power plane shall clear the edge of the PCB by 0.2".

Prior to routing, vias connecting all digital ground layers (GND) should be placed around the edge of the rigid PWB regions 0.025" from the board edges with a 0.100" spacing. It is also desirable to have all internal digital ground (GND) planes connected together in as many places as possible. If possible, all internal ground planes should be connected together with a minimum distance between connections of 0.5". Extra vias are not required if there are sufficient ground vias due to normal ground connections of devices. NOTE: All signal routing and signal vias should be inside the perimeter ring of ground vias.

Power and Ground pins of each component shall be connected to the power and ground planes with one via for each pin. Trace lengths for component power and ground pins should be minimized (ideally, less than 0.100"). Unused or spare device pins that are connected to power or ground may be connected together with a single via to power or ground. Ground plane slots are NOT allowed.

Route VOFFSET, VBIAS, and VRESET as a wide trace >20 mils (wider if space allows) with 20 mils spacing.

## Layout Guidelines (continued)

### 12.1.3 LVDS Signals

The LVDS signals shall be first. Each pair of differential signals must be routed together at a constant separation such that constant differential impedance (as in section [Board Stack and Impedance Requirements](#)) is maintained throughout the length. Avoid sharp turns and layer switching while keeping lengths to a minimum. The distance from one pair of differential signals to another shall be at least 2 times the distance within the pair.

### 12.1.4 Critical Signals

The critical signals on the board must be hand routed in the order specified below. In case of length matching requirements, the longer signals should be routed in a serpentine fashion, keeping the number of turns to a minimum and the turn angles no sharper than 45 degrees. Avoid routing long trace all around the PCB.

**Table 6. Timing Critical Signals**

GROUP	SIGNAL	CONSTRAINTS	ROUTING LAYERS
1	D_AP(0:15), D_AN(0:15), DCLK_AP, DCLK_AN, SCTRL_AN, SCTRL_AP, D_BP(0:15), D_BN(0:15), DCLK_BP, DCLK_BN, SCTRL_BN, SCTRL_BP, D_CP(0:15), D_CN(0:15), DCLK_CP, DCLK_CN, SCTRL_CN, SCTRL_CP, D_DP(0:15), D_DN(0:15), DCLK_DP, DCLK_DN, SCTRL_DN, SCTRL_DP.	Refer to <a href="#">Table 7</a> and <a href="#">Table 8</a>	Internal signal layers. Avoid layer switching when routing these signals.
2	RESET_ADDR_(0:3), RESET_MODE_(0:1), RESET_OEZ, RESET_SEL_(0:1), RESET_STROBE, RESET_IRQZ.		Internal signal layers. Top and bottom as required.
3	SCP_CLK, SCP_DO, SCP_DI, SCP_DMD_CSZ.		Any
4	Others	No matching/length requirement	Any

### 12.1.5 Flex Connector Plating

Plate all the pad area on top layer of flex connection with a minimum of 35 and maximum 50 micro-inches of electrolytic hard gold over a minimum of 150 micro-inches of electrolytic nickel.

### 12.1.6 Device Placement

Unless otherwise specified, all major components should be placed on top layer. Small components such as ceramic, non-polarized capacitors, resistors and resistor networks can be placed on bottom layer. All high frequency de-coupling capacitors for the ICs shall be placed near the parts. Distribute the capacitors evenly around the IC and locate them as close to the device's power pins as possible (preferably with no vias). In the case where an IC has multiple de-coupling capacitors with different values, alternate the values of those that are side by side as much as possible and place the smaller value capacitor closer to the device.

### 12.1.7 Device Orientation

It is desirable to have all polarized capacitors oriented with their positive terminals in the same direction. If polarized capacitors are oriented both horizontally and vertically, then all horizontal capacitors should be oriented with the "+" terminal the same direction and likewise for the vertically oriented ones.

### 12.1.8 Fiducials

Fiducials for automatic component insertion should be placed on the board according to the following guidelines or on recommendation from manufacturer:

- Fiducials for optical auto insertion alignment shall be placed on three corners of both sides of the PWB.
- Fiducials shall also be placed in the center of the land patterns for fine pitch components (lead spacing <0.05").
- Fiducials should be 0.050 inch copper with 0.100 inch cutout (antipad).

## 12.2 Layout Example

### 12.2.1 Board Stack and Impedance Requirements

Refer to [Figure 20](#) regarding guidance on the parameters.

#### PCB design:

Configuration:	Asymmetric dual stripline
Etch thickness (T):	1.0-oz copper (1.2 mil)
Flex etch thickness (T):	0.5-oz copper (0.6 mil)
Single-ended signal impedance:	50 $\Omega$ ( $\pm 10\%$ )
Differential signal impedance:	100 $\Omega$ ( $\pm 10\%$ )

#### PCB stack-up:

Reference plane 1 is assumed to be a ground plane for proper return path.

Reference plane 2 is assumed to be the I/O power plane or ground.

Dielectric material with a low Loss-Tangent, (Er): 3.8 (nominal)  
for example: Hitachi 679gs or equivalent.

Signal trace distance to reference plane 1 (H1): 5.0 mil (nominal)

Signal trace distance to reference plane 2 (H2): 34.2 mil (nominal)

Layout Example (continued)

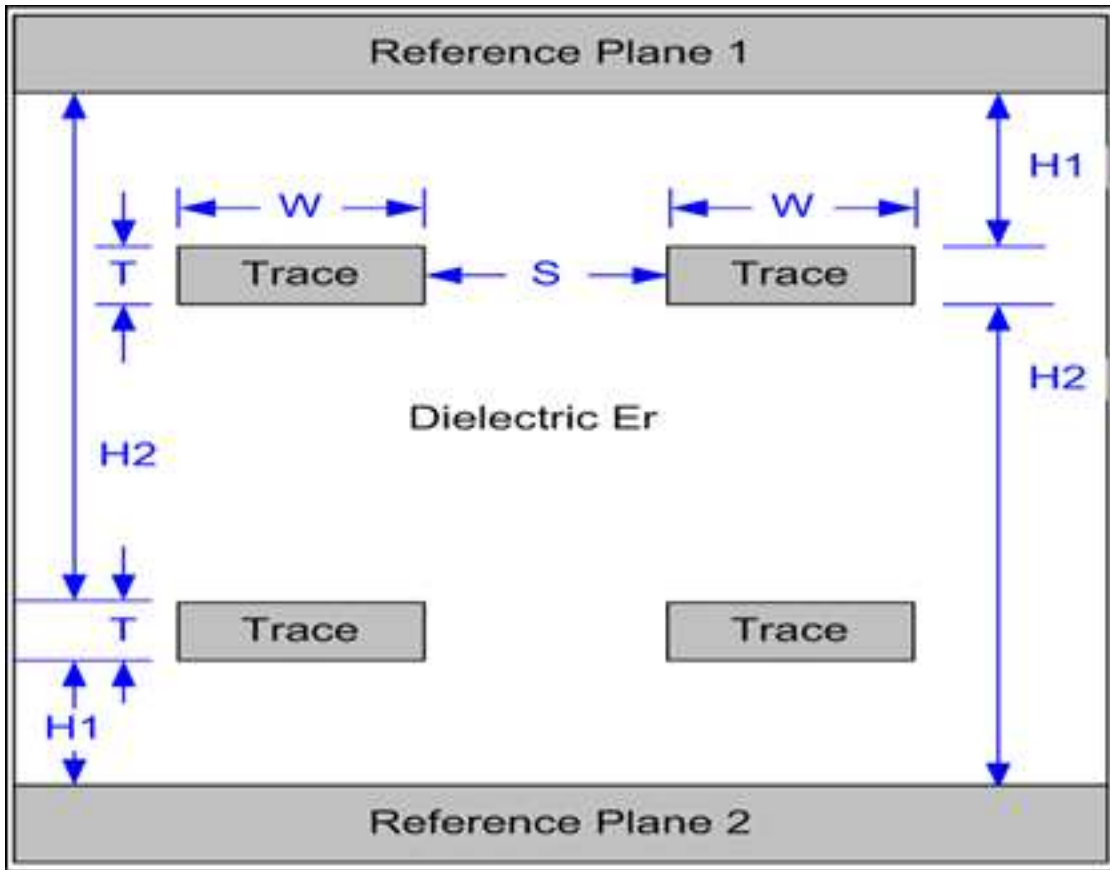

Figure 20. PCB Stack Geometries

**Layout Example (continued)**
**Table 7. General PCB Routing (Applies to All Corresponding PCB Signals)**

PARAMETER	APPLICATION	SINGLE-ENDED SIGNALS	DIFFERENTIAL PAIRS	UNIT
Line width (W)	Escape routing in ball field	4.4 (0.1)	4.3 (0.1)	mil (mm)
	PCB etch data or control	7 (0.18)	4.25 (0.11)	mil (mm)
	PCB etch clocks	7 (0.18)	4.25 (0.11)	mil (mm)
Differential signal pair spacing (S)	PCB etch data or control	N/A	5.75 <sup>(1)</sup> –0.15	mil (mm)
	PCB etch clocks	N/A	5.75 <sup>(1)</sup> –0.15	mil (mm)
Minimum differential pair-to-pair spacing (S)	PCB etch data or control	N/A	20 (0.51)	mil (mm)
	PCB etch clocks	N/A	20 (0.51)	mil (mm)
Minimum line spacing to other signals (S)	Escape routing in ball field	4 (0.1)	4 (0.1)	mil (mm)
	PCB etch data or control	10 (0.25)	20 (0.51)	mil (mm)
Maximum differential pair P-to-N length mismatch	PCB etch clocks	20 (0.51)	20 (0.51)	mil (mm)
	Total data	N/A	10 –0.25	mil (mm)
	Total data	N/A	10 –0.25	mil (mm)

(1) Spacing may vary to maintain differential impedance requirements

**Table 8. DMD Interface Specific Routing**

SIGNAL GROUP LENGTH MATCHING				
INTERFACE	SIGNAL GROUP	REFERENCE SIGNAL	MAX MISMATCH	UNIT
DMD (LVDS)	SCTRL_AN / SCTRL_AP D_AP(15:0)/ D_AN(15:0)	DCKA_P/ DCKA_N	± 50 (± 1.3)	mil (mm)
DMD (LVDS)	SCTRL_BN/ SCTRL_BP D_BP(15:0)/ D_BN(15:0)	DCKB_P/ DCKB_N	± 50 (± 1.3)	mil (mm)
DMD (LVDS)	SCTRL_CN/ SCTRL_CP D_CP(15:0)/ D_CN(15:0)	DCK_CP/ DCK_CN	± 50 (± 1.3)	mil (mm)
DMD (LVDS)	SCTRL_DN/ SCTRL_DP D_DP(15:0)/ D_DN(15:0)	DCK_CP/ DCK_CN	± 50 (± 1.3)	mil (mm)

Number of layer changes:

- Single-ended signals: Minimize
- Differential signals: Individual differential pairs can be routed on different layers but the signals of a given pair should not change layers.

**Table 9. DMD Signal Routing Length<sup>(1)</sup>**

BUS	MIN	MAX	UNIT
DMD (LVDS)	50	375	mm

(1) Max signal routing length includes escape routing.

**DLP9000**

ZHCS19A – SEPTEMBER 2014 – REVISED OCTOBER 2015

[www.ti.com.cn](http://www.ti.com.cn)

Stubs: Stubs should be avoided.

Termination Requirements: DMD interface: None – The DMD receiver is differentially terminated to 100  $\Omega$  internally.

Connector (DMD-LVDS interface bus only):

High-speed connectors that meet the following requirements should be used:

- Differential crosstalk: <5%
- Differential impedance: 75 to 125  $\Omega$

Routing requirements for right-angle connectors: When using right-angle connectors, P-N pairs should be routed in the same row to minimize delay mismatch. When using right-angle connectors, propagation delay difference for each row should be accounted for on associated PCB etch lengths. Voltage or low frequency signals should be routed on the outer layers. Signal trace corners shall be no sharper than 45 degrees. Adjacent signal layers shall have the predominant traces routed orthogonal to each other.

## 13 器件和文档支持

### 13.1 器件支持

#### 13.1.1 器件处理

DMD 上的所有外部信号均不受静电放电的损害，经测试符合 JESD22-A114-B 静电放电 (ESD) 敏感度测试人体模型 (HBM)。

表 10. DMD ESD 保护限值

封装引脚类型	电压 (最大值)	单位
输入	2000	V
输出	2000	V
VCC	2000	V
VCCI	2000	V
VOFFSET	2000	V
VBIAS	2000	V
VRESET	2000	V
所有 MBRST	2000	V

所有 CMOS 器件均需遵循适当的静电放电 (ESD) 处理程序。请参见图纸 2504641 DMD 处理规范，了解关于对 DMD 实施 ESD 保护以及保护 DMD 玻璃和电触点的预防措施。请参见图纸 2504640 DMD 玻璃清洁程序，掌握 DMD 玻璃的正确清洁方式，避免损坏玻璃表面上的抗反射涂层。

#### 13.1.2 器件命名规则

图 21 提供了读取任一 DLP 器件完整器件名称的图例。

表 11. 封装专用信息

封装类型	替代名称
FLS	LCCC



图 21. 器件命名规则

#### 13.1.3 器件标记

器件标记将包括可读信息和一个二维矩阵码。图 22 中显示了可读信息。二维矩阵码是一个字母数字字符串，其中包含 DMD 部件号、序列号的第 1 部分和序列号的第 2 部分。DMD 序列号 (第 1 部分) 的首字符为制造年份。DMD 序列号 (第 1 部分) 的第二个字符为制造月份。DMD 序列号 (第 2 部分) 的最后一个字符为偏置电压二进制字母。

**图 22. DMD 标记**

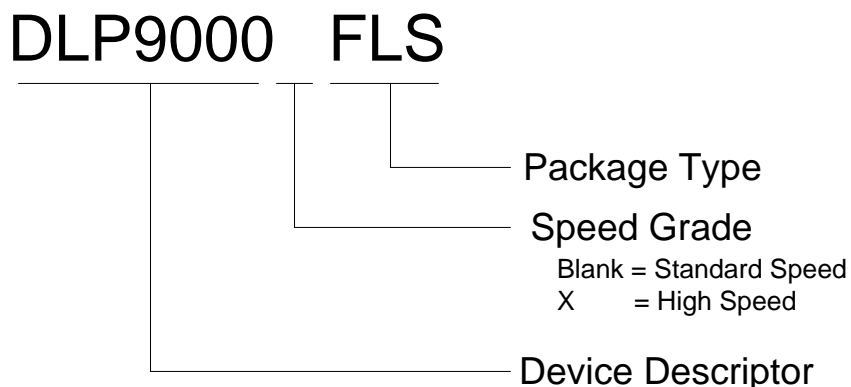
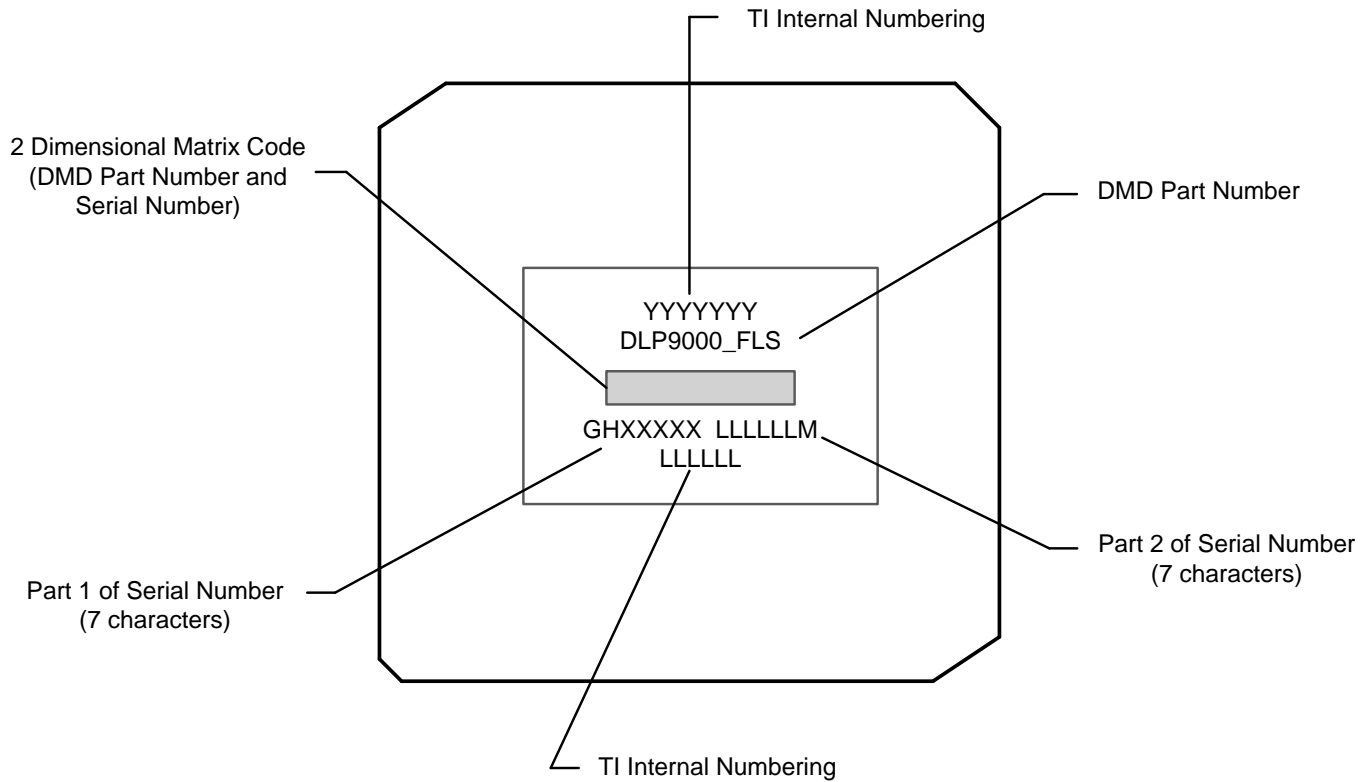
## 13.2 文档支持

### 13.2.1 相关文档

以下文档包含使用 DLP9000 系列器件的更多信息:

- 《DLPC900 数字控制器数据表》(文献编号: [DLPS037](#))
- 《DLPC900 软件编程人员指南》(文献编号: [DLPU018](#))
- 《DLPC910 数字控制器数据表》(文献编号: [DLPS064](#))
- 《DLPR910 配置 PROM 数据表》(文献编号: [DLPS065](#))

## 13.3 社区资源

The following links connect to TI community resources. Linked contents are provided "AS IS" by the respective contributors. They do not constitute TI specifications and do not necessarily reflect TI's views; see TI's [Terms of Use](#).

**TI E2E™ Online Community** *TI's Engineer-to-Engineer (E2E) Community*. Created to foster collaboration among engineers. At [e2e.ti.com](http://e2e.ti.com), you can ask questions, share knowledge, explore ideas and help solve problems with fellow engineers.

**Design Support** *TI's Design Support* Quickly find helpful E2E forums along with design support tools and contact information for technical support.

## 13.4 商标

E2E is a trademark of Texas Instruments.

All other trademarks are the property of their respective owners.

## 13.5 静电放电警告



这些装置包含有限的内置 ESD 保护。存储或装卸时，应将导线一起截短或将装置放置于导电泡棉中，以防止 MOS 门极遭受静电损伤。

## 13.6 Glossary

SLYZ022 — TI Glossary.

This glossary lists and explains terms, acronyms, and definitions.

## 14 机械、封装和可订购信息

以下页中包括机械、封装和可订购信息。这些信息是针对指定器件可提供的最新数据。这些数据会在无通知且不对本文档进行修订的情况下发生改变。欲获得该数据表的浏览器版本，请查阅左侧的导航栏

### 14.1 热特性

要使 DMD 达到最佳性能，需要对 DMD 外壳的最高温度、有源阵列中任一微镜的最高温度以及封装上任意两点间的温度梯度和封装内的温度梯度进行适当管理。

关于适用的温度限值，请参见 [Absolute Maximum Ratings](#) 和 [Recommended Operating Conditions](#)。

### 14.2 封装热阻

DMD 经设计可将吸收和消散的热量传递回 FLS 系列封装，然后通过适当的热管理系统排出。该热管理系统必须能够将封装维持在热测试点位置上指定的工作温度范围内（请参见 [Figure 15](#) 或 [Micromirror Array Temperature Calculation](#)）。DMD 上的总体热负载通常由有源区域吸收的入射光驱动，不过可能还会有一部分来自窗口孔隙吸收的光能、阵列的电气功耗以及寄生发热。有关热阻的信息，请参见 [Thermal Information](#)。

### 14.3 外壳温度

可以直接测量 DMD 外壳的温度。为确保测量结果的一致性，定义了一个热测试点位置，如 [Figure 15](#) 和 [Micromirror Array Temperature Calculation](#) 所示。

**PACKAGING INFORMATION**

Orderable Device	Status (1)	Package Type	Package Drawing	Pins	Package Qty	Eco Plan (2)	Lead finish/ Ball material (6)	MSL Peak Temp (3)	Op Temp (°C)	Device Marking (4/5)	Samples
DLP9000BFLS	ACTIVE	CLGA	FLS	355	1	RoHS & Green	NI-PD-AU	N / A for Pkg Type	0 to 70		Samples

(1) The marketing status values are defined as follows:

**ACTIVE:** Product device recommended for new designs.

**LIFEBUY:** TI has announced that the device will be discontinued, and a lifetime-buy period is in effect.

**NRND:** Not recommended for new designs. Device is in production to support existing customers, but TI does not recommend using this part in a new design.

**PREVIEW:** Device has been announced but is not in production. Samples may or may not be available.

**OBSOLETE:** TI has discontinued the production of the device.

(2) **RoHS:** TI defines "RoHS" to mean semiconductor products that are compliant with the current EU RoHS requirements for all 10 RoHS substances, including the requirement that RoHS substance do not exceed 0.1% by weight in homogeneous materials. Where designed to be soldered at high temperatures, "RoHS" products are suitable for use in specified lead-free processes. TI may reference these types of products as "Pb-Free".

**RoHS Exempt:** TI defines "RoHS Exempt" to mean products that contain lead but are compliant with EU RoHS pursuant to a specific EU RoHS exemption.

**Green:** TI defines "Green" to mean the content of Chlorine (Cl) and Bromine (Br) based flame retardants meet JS709B low halogen requirements of <=1000ppm threshold. Antimony trioxide based flame retardants must also meet the <=1000ppm threshold requirement.

(3) MSL, Peak Temp. - The Moisture Sensitivity Level rating according to the JEDEC industry standard classifications, and peak solder temperature.

(4) There may be additional marking, which relates to the logo, the lot trace code information, or the environmental category on the device.

(5) Multiple Device Markings will be inside parentheses. Only one Device Marking contained in parentheses and separated by a "-" will appear on a device. If a line is indented then it is a continuation of the previous line and the two combined represent the entire Device Marking for that device.

(6) Lead finish/Ball material - Orderable Devices may have multiple material finish options. Finish options are separated by a vertical ruled line. Lead finish/Ball material values may wrap to two lines if the finish value exceeds the maximum column width.

**Important Information and Disclaimer:**The information provided on this page represents TI's knowledge and belief as of the date that it is provided. TI bases its knowledge and belief on information provided by third parties, and makes no representation or warranty as to the accuracy of such information. Efforts are underway to better integrate information from third parties. TI has taken and continues to take reasonable steps to provide representative and accurate information but may not have conducted destructive testing or chemical analysis on incoming materials and chemicals. TI and TI suppliers consider certain information to be proprietary, and thus CAS numbers and other limited information may not be available for release.

In no event shall TI's liability arising out of such information exceed the total purchase price of the TI part(s) at issue in this document sold by TI to Customer on an annual basis.

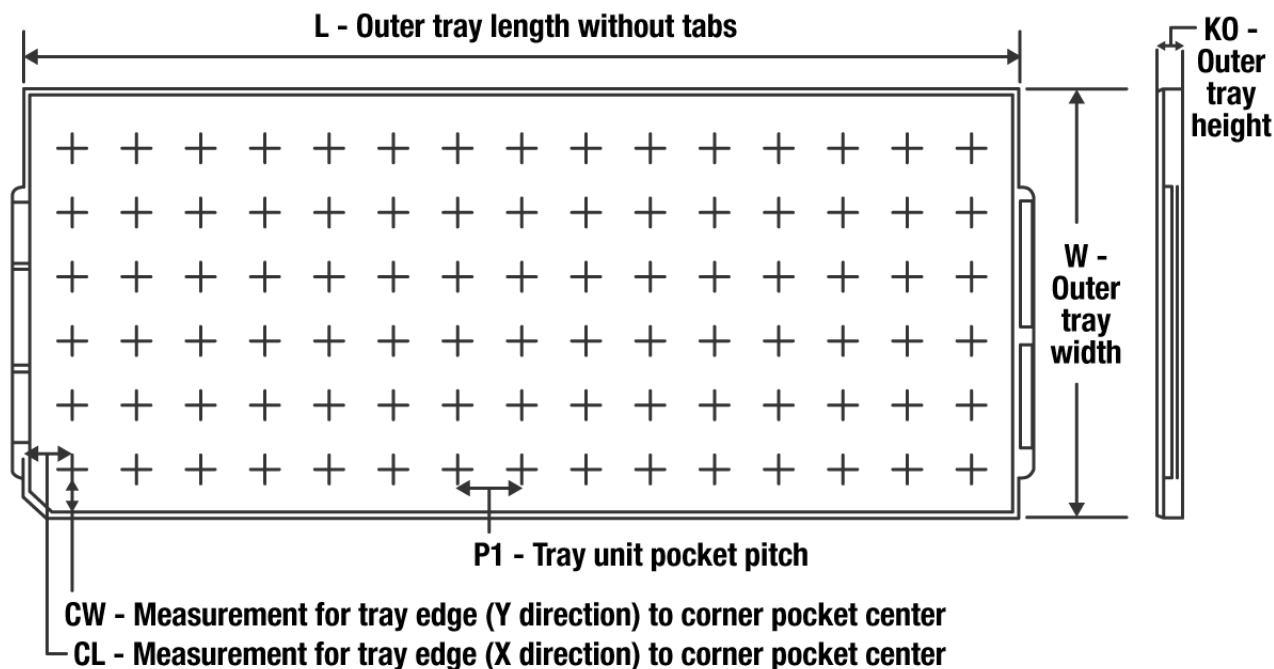
**TRAY**

Chamfer on Tray corner indicates Pin 1 orientation of packed units.

\*All dimensions are nominal

Device	Package Name	Package Type	Pins	SPQ	Unit array matrix	Max temperature (°C)	L (mm)	W (mm)	K0 (µm)	P1 (mm)	CL (mm)	CW (mm)
DLP9000BFLS	FLS	CLGA	355	1	4 x 5	60	254.76	221.74	48590	48.59	30.22	31.98

REVISIONS			
REV	DESCRIPTION	DATE	APPROVED
A	ECO 2098262, INITIAL RELEASE	4/16/09	M. AVERY
B	ECO 2099196, CHANGE DESIGN TO OVAL WINDOW	5/22/09	M. AVERY
C	ECO 2150560, ADD NOTE 15.	05/12/15	M. AVERY
D	ECO 2179202, CHG WINDOW MARK TO INCLUDE UV	1/22/19	B. HASKETT
E	ECO 2179654, DELETE NOTE 7	2/15/19	B. HASKETT

NOTES: UNLESS OTHERWISE SPECIFIED:

- 1 INTERPRET DIMENSIONS IN ACCORDANCE WITH ASME Y14.5M-1994.
- 2 DATUM A (SYSTEM INTERFACE PLANE) ESTABLISHED BY THREE DATUM AREAS SHOWN IN VIEW A (SHEET 2).
- 3 DATUM B ESTABLISHED BY TWO DATUM AREAS SHOWN IN VIEW A (SHEET 2).
- 4 DATUM C ESTABLISHED BY DATUM AREA SHOWN IN VIEW A (SHEET 2).
- 5 LOCALIZED BACKSIDE SURFACE FLATNESS APPLIES TO ENTIRE SURFACE.
- 6 SUBSTRATE INDEX MARK, BACK INDEX PAD, SYMBOLIZATION PAD, SEAL RING, AND WINDOW FRAME TO BE ELECTRICALLY CONNECTED TO VSS PLANE IN SUBSTRATE.
- 7 (DELETED)
- 8 ROTATION ANGLE OF DMD ACTIVE ARRAY IS A REFINEMENT OF THE LOCATION TOLERANCE AND IS THE MAXIMUM VALUE ALLOWED.
- 9 SUBSTRATE EDGE PERPENDICULARITY TOLERANCE APPLIES TO ENTIRE SURFACE.
- 10 DIE PARALLELISM TOLERANCE APPLIES TO DMD ACTIVE ARRAY ONLY.
- 11 DIE HEIGHT TOLERANCE APPLIES TO CENTER OF DMD ACTIVE ARRAY ONLY.
- 12 DMD ACTIVE ARRAY ROTATION AND LOCATION DIMENSIONS ARE RELATED TO DATUM A (PRIMARY), DATUM B (SECONDARY), AND DATUM C (TERTIARY).
- 13 WINDOW SHALL BE ORIENTED SUCH THAT I.D. MARK ALIGNS WITH SUBSTRATE INDEX MARK AS SHOWN.
- 14 n AND ? ARE WILD CARD CHARACTERS. n=4 FOR STANDARD VISIBLE WINDOWS; n=7 FOR UV-TRANSMISSIVE WINDOWS. ? CAN BE ANY LETTER.
- 15 SUBSTRATES PLATED WITH Ni/Au SHALL HAVE THE THREE-DIGIT NUMERICAL MARKING IN THE SYMBOLIZATION PAD, AS SHOWN. SUBSTRATES WITH Ni/Pd/Au SHALL HAVE THE SAME MARKING, BUT ROTATED UPSIDE-DOWN.

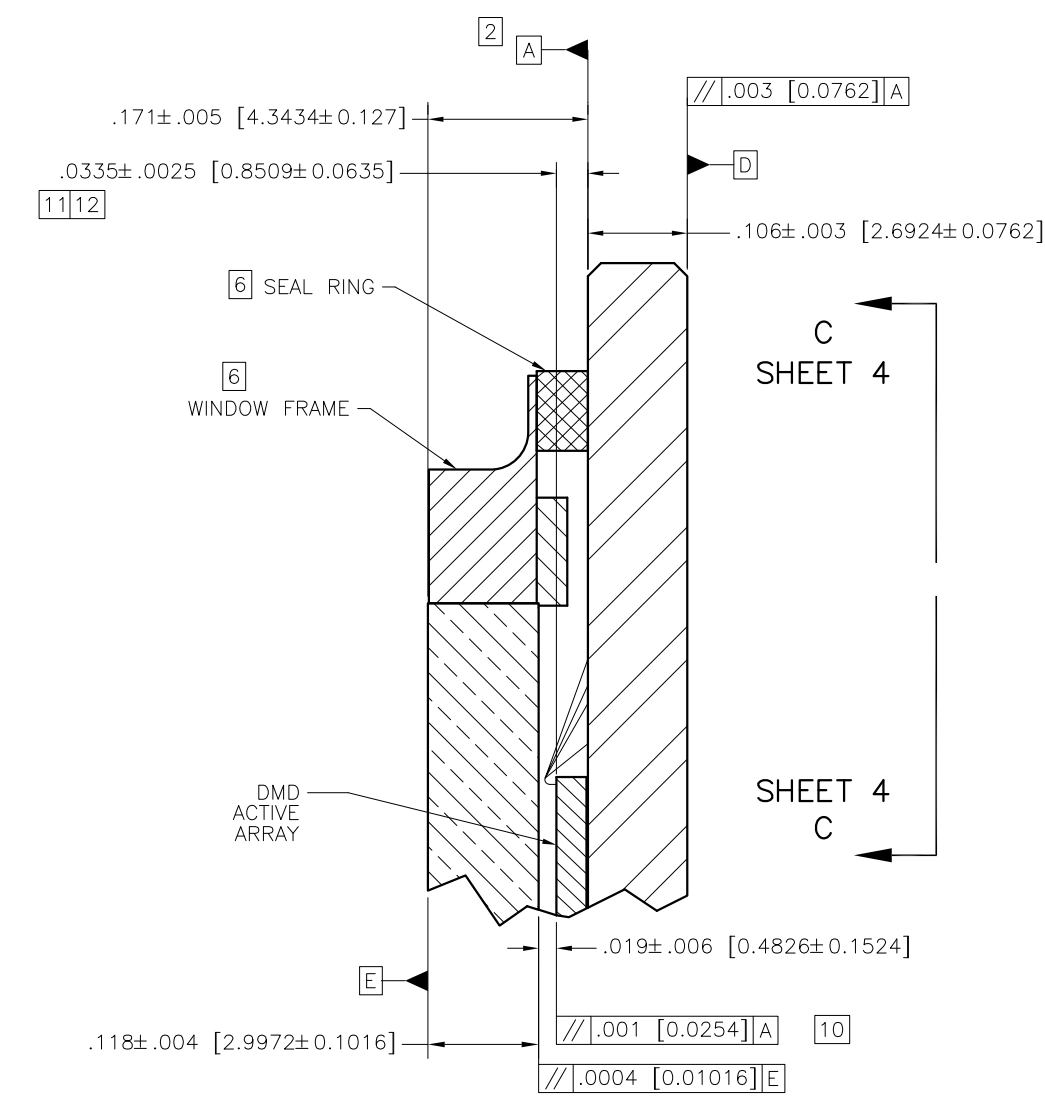
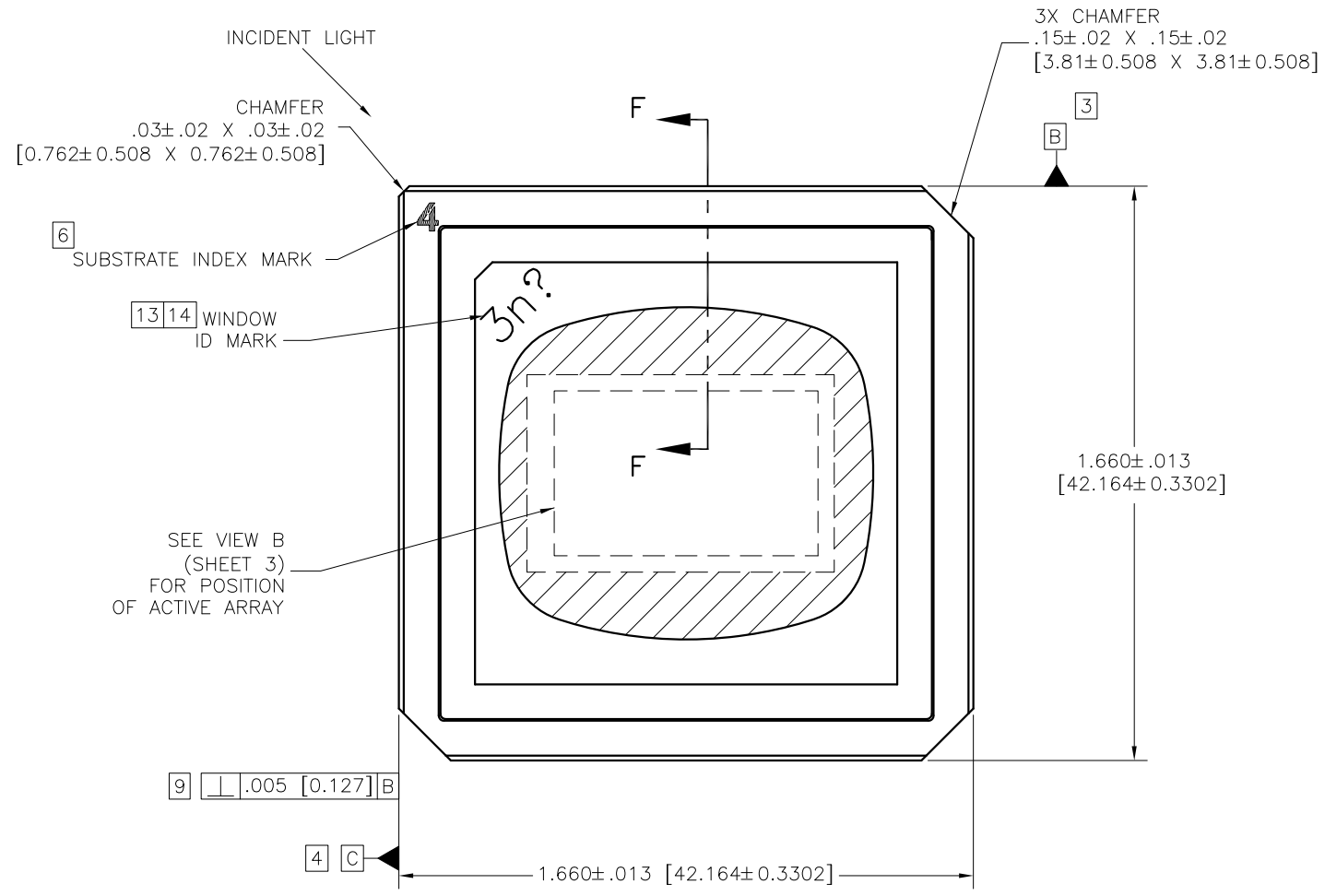

SECTION F-F  
SCALE 10/1

-1	ITEM	PART OR IDENTIFYING NUMBER	NOMENCLATURE OR DESCRIPTION	NOTES
QTY	NO			

PARTS LIST		UNLESS OTHERWISE SPECIFIED	
DWN	M. AVERY	DATE	4/02/09
ENGR	M. AVERY	DATE	4/02/09
QA			
APVD			

DIMENSIONS ARE IN INCHES[MILLIMETERS] TOLERANCES: ANGLES ± 1° 3 PLACE DECIMALS ± .005[0.127] 2 PLACE DECIMALS ± .01[0.254]		HOLE TOLERANCE .013 THRU .126 ± .004 .126 THRU .251 ± .005 .251 THRU .500 ± .006 .501 THRU .750 ± .008 .751 THRU 1.000 ± .010	
REMOVE ALL BURRS AND SHARP EDGES CONCENTRICITY MACHINED DIAMETERS .010 FIM DIMENSIONAL LIMITS APPLY BEFORE PROCESSES PARENTHETICAL INFO FOR REF ONLY		TEXAS INSTRUMENTS Dallas, Texas ICD, MECHANICAL, DMD .9" WQXGA 2XLVDS TYPE A (FLS PACKAGE)	
SIZE	D	DRAWING NO	2510425
SCALE	4/1	SHEET	1 OF 4

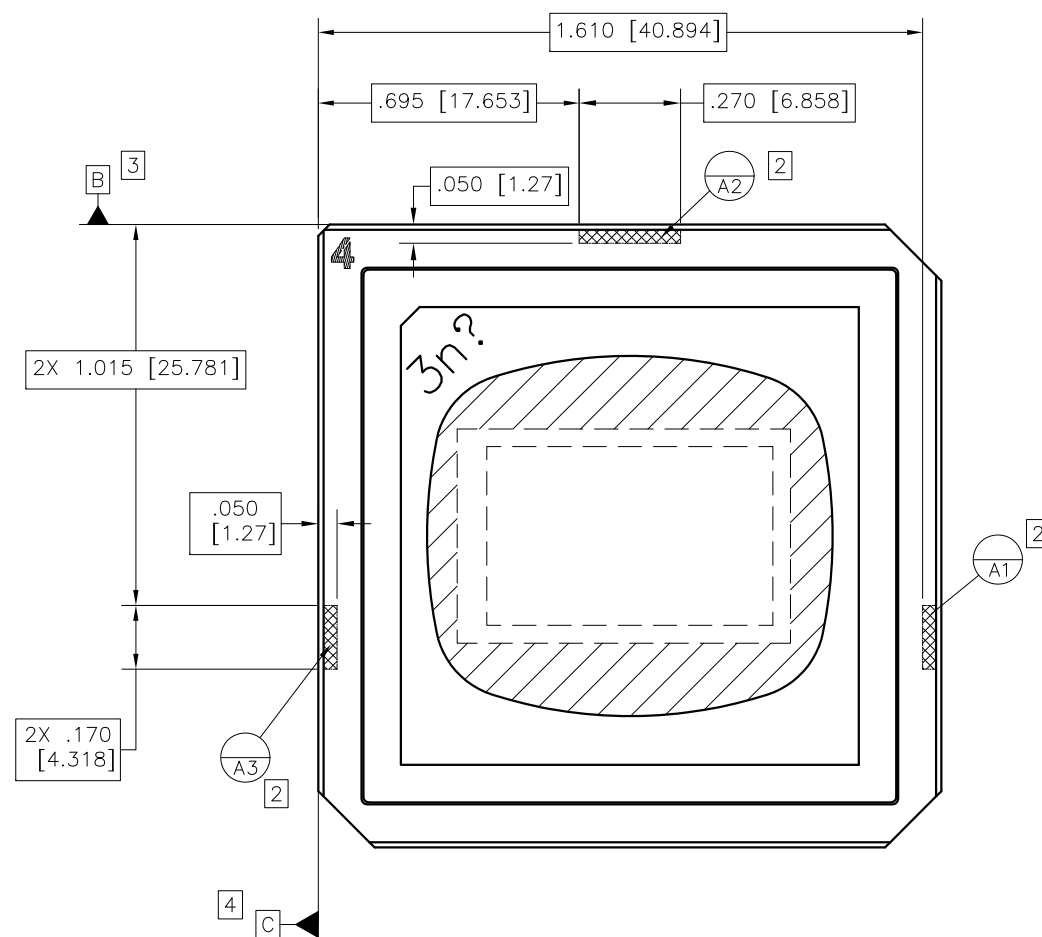
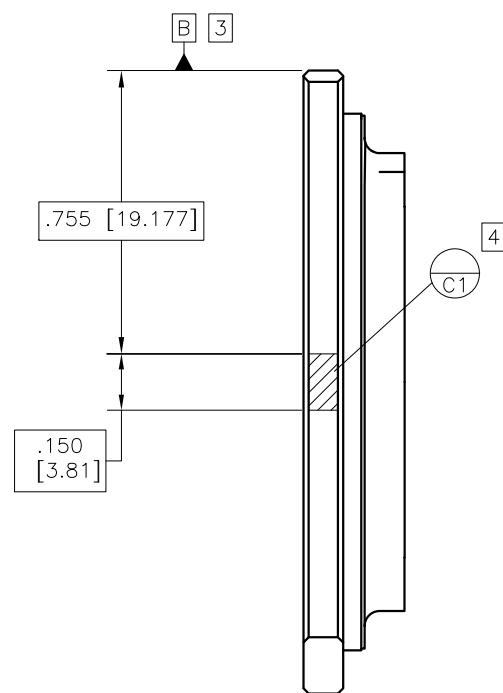
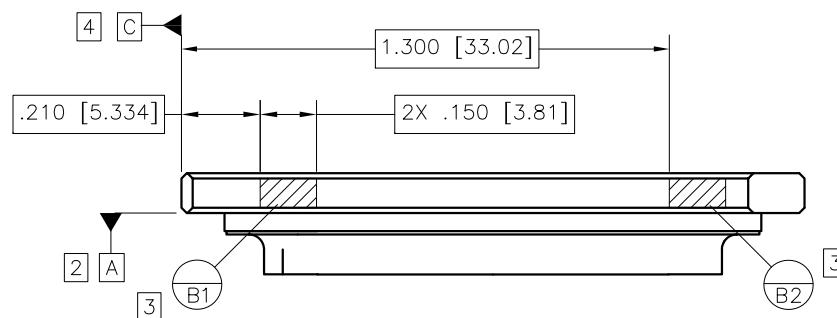

VIEW A (SHEET 1 NOTES)  
 DATUM A, B AND C DETAILS

8

7

6

5

4

3

DWG NO 2510425 SH 3

1

D

D

INCIDENT LIGHT

C

C

B

B

A

A

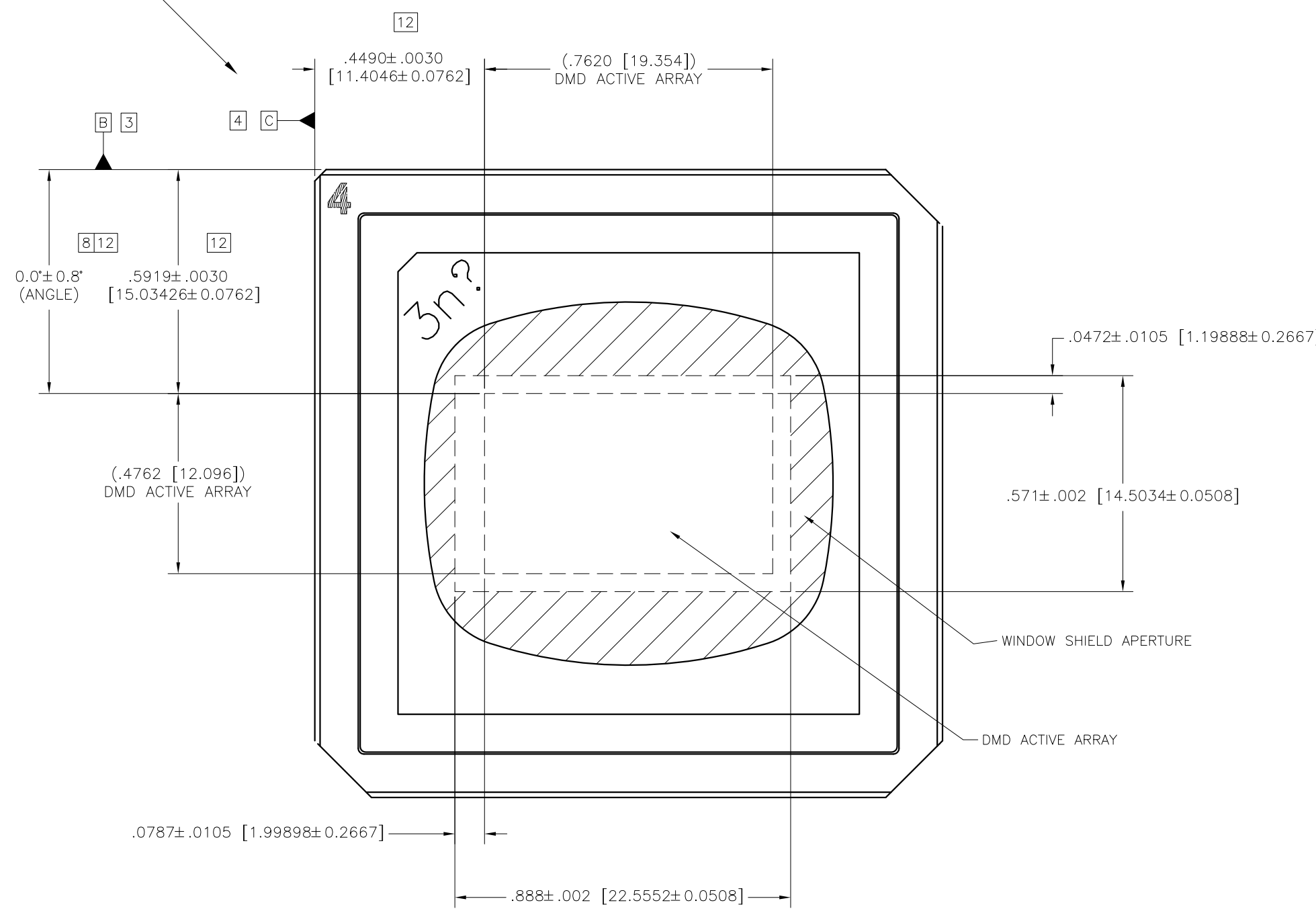

VIEW B (SHEET 1)  
 POSITION OF ACTIVE ARRAY  
 SCALE 6/1

ACED2c

8

7

6

5

4

3

2

1

D

D

C

C

B

B

A

A

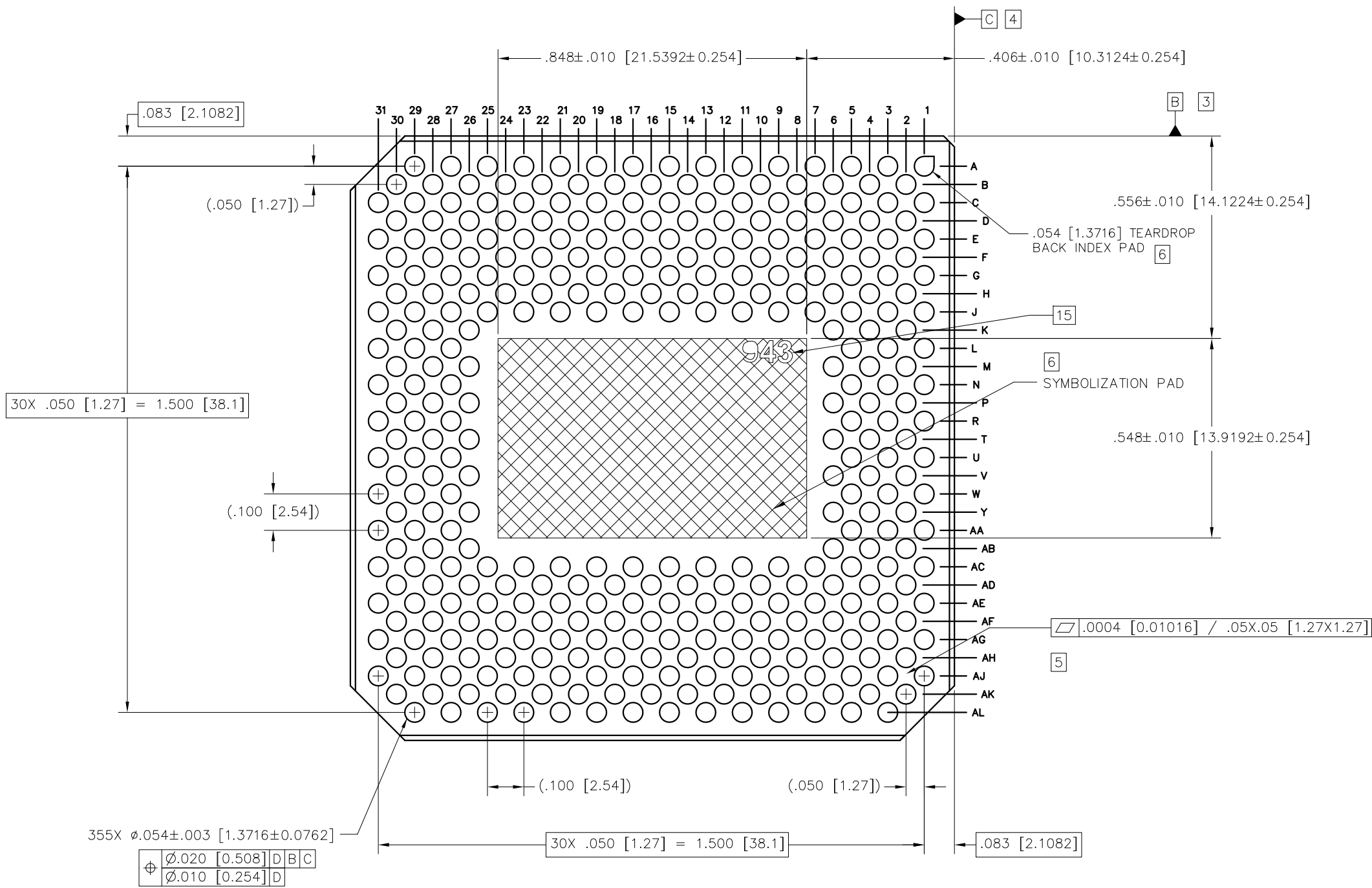

VIEW C-C (SHEET 1)  
 BACK PADS  
 SCALE 6/1

## 重要声明和免责声明

TI“按原样”提供技术和可靠性数据（包括数据表）、设计资源（包括参考设计）、应用或其他设计建议、网络工具、安全信息和其他资源，不保证没有瑕疵且不做任何明示或暗示的担保，包括但不限于对适销性、某特定用途方面的适用性或不侵犯任何第三方知识产权的暗示担保。

这些资源可供使用 TI 产品进行设计的熟练开发人员使用。您将自行承担以下全部责任：(1) 针对您的应用选择合适的 TI 产品，(2) 设计、验证并测试您的应用，(3) 确保您的应用满足相应标准以及任何其他功能安全、信息安全、监管或其他要求。

这些资源如有变更，恕不另行通知。TI 授权您仅可将这些资源用于研发本资源所述的 TI 产品的应用。严禁对这些资源进行其他复制或展示。您无权使用任何其他 TI 知识产权或任何第三方知识产权。您应全额赔偿因在这些资源的使用中对 TI 及其代表造成的任何索赔、损害、成本、损失和债务，TI 对此概不负责。

TI 提供的产品受 [TI 的销售条款](#) 或 [ti.com](#) 上其他适用条款/TI 产品随附的其他适用条款的约束。TI 提供这些资源并不会扩展或以其他方式更改 TI 针对 TI 产品发布的适用的担保或担保免责声明。

TI 反对并拒绝您可能提出的任何其他或不同的条款。

邮寄地址：Texas Instruments, Post Office Box 655303, Dallas, Texas 75265

Copyright © 2022，德州仪器 (TI) 公司